

Q28-100GP4-BXD3327-10-I-AO

MSA and TAA 100GBase-BX PAM4 QSFP28 Transceiver Single Lambda (SMF, 1331nmTx/1271nmRx, 10km w/FEC, LC, DOM, -40 to 85C)

Features

- Compliant with 100G Lambda MSA 100G-LR Specifications
- Single 3.3V Power Supply
- Compliant with SFF-8636
- Bidi LC Connectors
- Industrial Temperature -40 to 85 Celsius
- Single-mode Fiber
- Metal with Lower EMI
- Hot Pluggable
- RoHS Compliant and Lead Free
- Excellent ESD Protection



Applications

- Datacenter
- 100GBase Ethernet

Product Description

This MSA Compliant QSFP28 transceiver provides 100GBase-BX throughput up to 10km over single-mode fiber (SMF) using a wavelength of 1331nmTx/1271nmRx via an LC connector. It is built to MSA standards and is uniquely serialized and data-traffic and application tested to ensure that they will integrate into your network seamlessly. Digital optical monitoring (DOM) support is also present to allow access to real-time operating parameters. This transceiver is Trade Agreements Act (TAA) compliant. We stand behind the quality of our products and proudly offer a limited lifetime warranty.

AddOn's transceivers are RoHS compliant and lead-free.

TAA refers to the Trade Agreements Act (19 U.S.C. & 2501-2581), which is intended to foster fair and open international trade. TAA requires that the U.S. Government may acquire only "U.S. – made or designated country end products."



Absolute Maximum Ratings

Parameter	Symbol	Min.	Typ.	Max.	Unit	Notes
Maximum Supply Voltage	V _{cc}	0		3.6	V	
Data Input Voltage		-0.3		3.6	V	
Control Input Voltage		-0.3		4	V	
Storage Temperature	T _{stg}	-40		85	°C	
Operating Case Temperature	T _c	0		70	°C	
Relative Humidity	RH	5		85	%	
Data Rate	BR		53.125		GBd	
Bit Error Rate	BER			2.4x10 ⁻⁴		1
Supported Link Length on 9/125um SMF, 53.125 GBd	L		10		km	2

Notes:

1. Tested with a PRBS31Q test pattern for 53.125 GBd operation.
2. Distances are based on FC-PI-6 Rev. 3.1 and IEEE 802.3 standards, with FEC.

Electrical Characteristics

Parameter	Symbol	Min.	Typ.	Max.	Unit	Notes
Power Supply Voltage	V _{cc}	3.135	3.3	3.465	V	
Module Supply Current	I _{cc}			1212	mA	
Power Dissipation	P _{DISS}			4000	mW	
Transmitter						
Differential Data Input Swing	V _{IN} , p-p	90	100	110	mVp-p	
Differential Input Impedance	Z _{IN}	90	100	110	Ω	
Receiver						
Differential Data Output Swing	V _{OUT} , p-p	300		900	mVp-p	
Differential Output Impedance	Z _{OUT}	90	100	110	Ω	

Optical Characteristics

Parameter	Symbol	Min.	Typ.	Max.	Unit	Notes
Transmitter						
Center Wavelength	λ_C	1324.5	1331	1337.5	nm	
Extinction Ratio	ER	3.5			dB	
Launch Optical Power (Average)	Po	-1.4		4.5	dBm	1
Launch Optical Power (OMA)	Poma	0.7		4.7	dBm	
Transmitter and dispersion penalty eye closure for PAM4	TDECQ			3.4	dB	
RIN17.1OMA (max)	RIN			-136	dB/Hz	
Optical Return Loss Tolerance	ORLT			15.6	dB	
Pout @TX-Disable Asserted	Poff			-30	dBm	
Receiver						
Center Wavelength	λ_C	1264.5	1271	1277.5	nm	
Receiver Sensitivity (OMA)	RxSENS			-6.1	dBm	2
Receiver Overload (Pavg)	POL	4.5			dBm	
Receiver reflectance				-26	dB	
LOS De-Assert	LOSD			-12	dBm	
LOS Assert	LOSA	-18			dBm	
LOS Hysteresis		0.5			dB	

Notes:

1. Class 1 Laser Safety per FDA/CDRH and EN (IEC) 60825 regulations.
2. Measured with PRBS31Q test pattern, 53.125GBd, BER<2.4×10⁻⁴.

Pin Descriptions

Pin	Logic	Symbol	Name/Descriptions	Notes
1		GND	Module Ground.	1
2	CML-I	Tx2-	Transmitter Inverted Data Input.	
3	CML-I	Tx2+	Transmitter Non-Inverted Data Output.	
4		GND	Module Ground.	1
5	CML-I	Tx4-	Transmitter Inverted Data Input.	
6	CML-I	Tx4+	Transmitter Non-Inverted Data Output.	
7		GND	Module Ground.	1
8	LVTLL-I	ModSelL	Module Select.	
9	LVTLL-I	ResetL	Module Reset.	
10		VccRx	+3.3V Receiver Power Supply.	2
11	LVC MOS-I/O	SCL	2-Wire Serial Interface Clock.	
12	LVC MOS-I/O	SDA	2-Wire Serial Interface Data.	
13		GND	Module Ground.	
14	CML-O	Rx3+	Receiver Non-Inverted Data Output.	
15	CML-O	Rx3-	Receiver Inverted Data Output.	
16		GND	Module Ground.	1
17	CML-O	Rx1+	Receiver Non-Inverted Data Output.	
18	CML-O	Rx1-	Receiver Inverted Data Output.	
19		GND	Module Ground.	1
20		GND	Module Ground.	1
21	CML-O	Rx2-	Receiver Inverted Data Output.	
22	CML-O	Rx2+	Receiver Non-Inverted Data Output.	
23		GND	Module Ground.	1
24	CML-O	Rx4-	Receiver Inverted Data Output.	1
25	CML-O	Rx4+	Receiver Non-Inverted Data Output.	
26		GND	Module Ground.	1
27	LVTTL-O	ModPrsL	Module Present.	
28	LVTTL-O	IntL	Interrupt.	
29		VccTx	+3.3V Transmitter Power Supply.	2
30		Vcc1	+3.3V Power Supply.	2
31	LVTTL-I	LPMoDe	Low-Power Mode.	
32		GND	Module Ground.	1
33	CML-I	Tx3+	Transmitter Non-Inverted Data Input.	
34	CML-I	Tx3-	Transmitter Inverted Data Output.	
35		GND	Module Ground.	1

36	CML-I	Tx1+	Transmitter Non-Inverted Data Input.	
37	CML-I	Tx1-	Transmitter Inverted Data Output.	
38		GND	Module Ground.	1

Notes:

1. GND is the symbol for signal and supply (power) common for the QSFP28 module. All are common within the QSFP28 module, and all module voltages are referenced to this potential unless otherwise noted. Connect these directly to the host board signal-common ground plane.
2. VccRx, Vcc1, and VccTx are the receiver and transmitter power supplies and shall be applied concurrently. Recommended host board power supply filtering is shown below. VccRx, Vcc1, and VccTx may be internally connected within the QSFP28 transceiver module in any combination. The connector pins are each rated for a maximum current of 1000mA.

Electrical Pin-Out Details

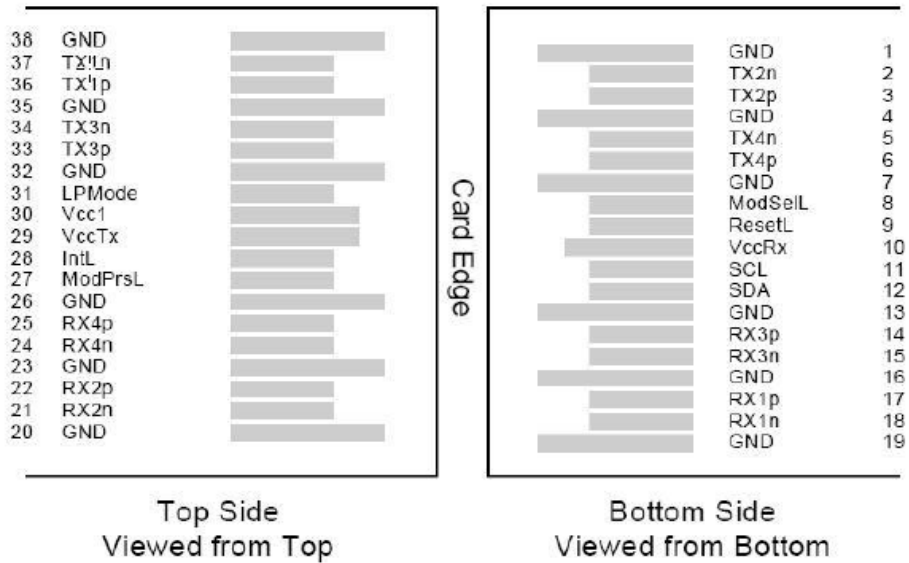

Block Diagram

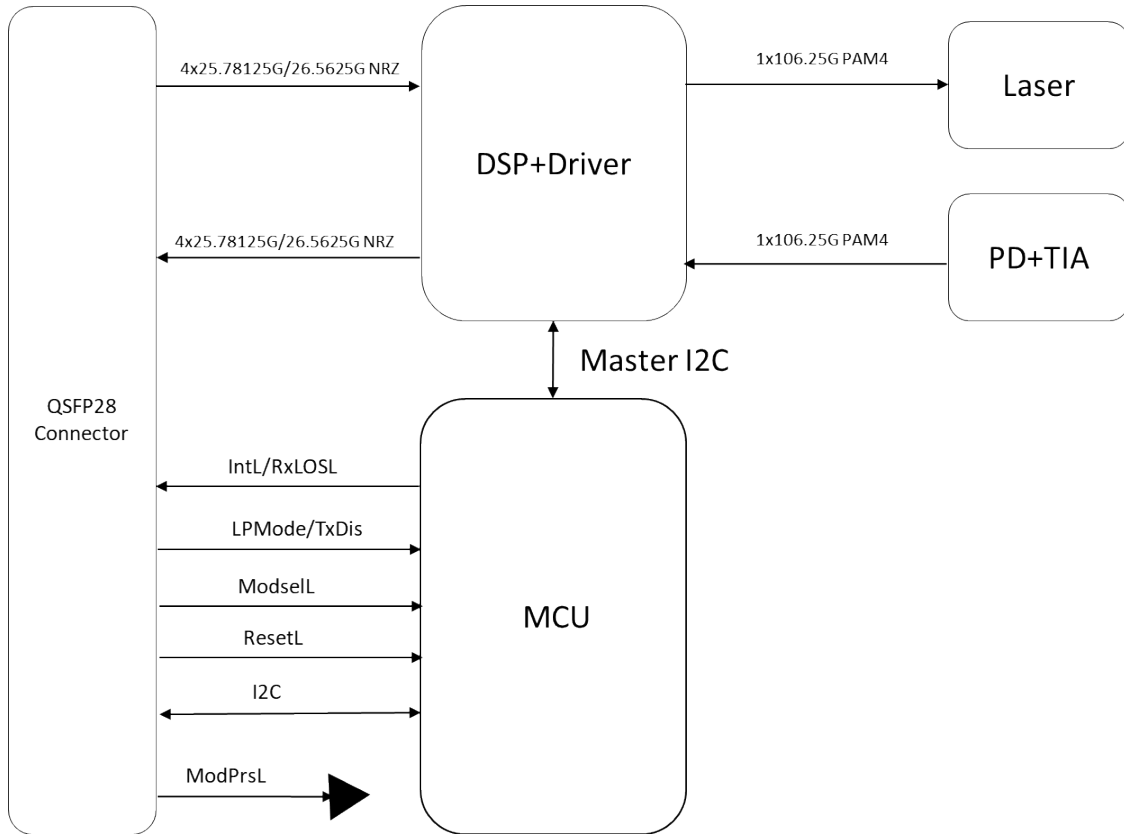

Mechanical Specifications

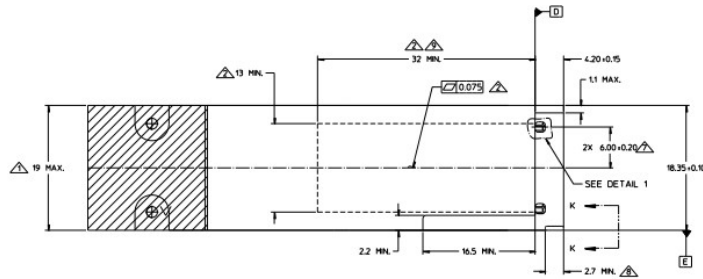

- ⊥ INDICATED DIMENSIONS DEFINE ENLARGED SECTION OF TRANSCEIVER THAT EXTENDS OUTSIDE OF CAGE TO ACCOMMODATE MATING PLUG AND ACTUATOR MECHANISM
- ⚙ FLATNESS APPLIES FOR INDICATED LENGTH AND A MIN WIDTH OF 13MM - SURFACE TO BE THERMALLY CONDUCTIVE
- ⚙ INDICATED SURFACES (ALL 4 SIDES) TO BE CONDUCTIVE FOR CONNECTION TO CHASSIS GROUND
- ⚙ DIMENSION APPLIES TO LATCH MECHANISM
- ⚙ INDICATED DIMENSION APPLIES TO THE LOCATION OF THE EDGE OF THE MODULE BOARD PAD. DATUM H, CONTACTS 21, 22, 36, AND 37 ARE VISIBLE.
- ⚙ INDICATED DIMENSION TO INCLUDE BALL TRAVEL
- ⚙ INDICATED DIMENSIONS APPLY TO OPENINGS IN HOUSING
- ⚙ FEATURE MAY BE LONGER THAN SHOWN
- ⚙ HIGHER WATTAGE MODULES MAY REQUIRE ADDITIONAL SPACE FOR COOLING

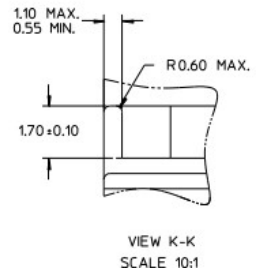
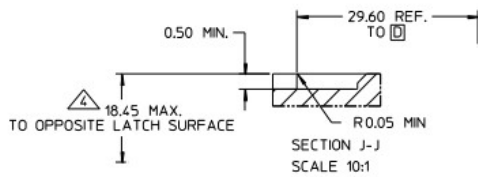
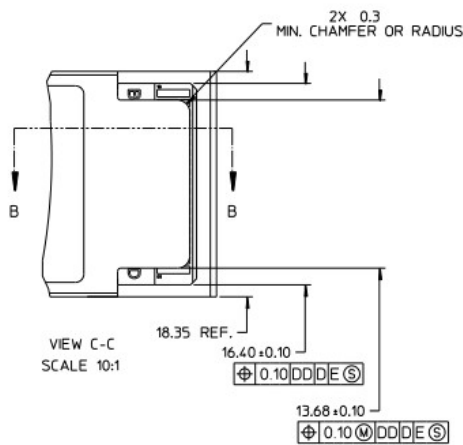
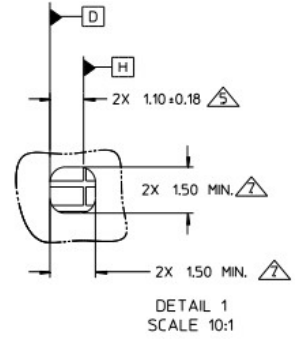
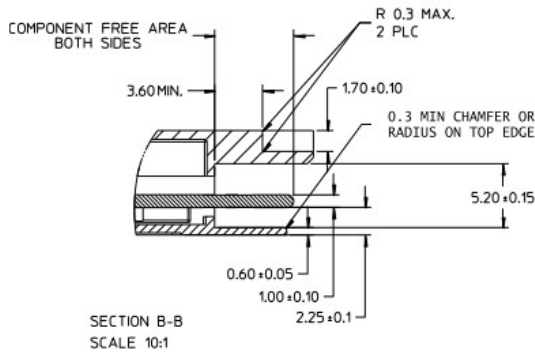
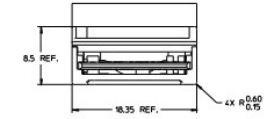
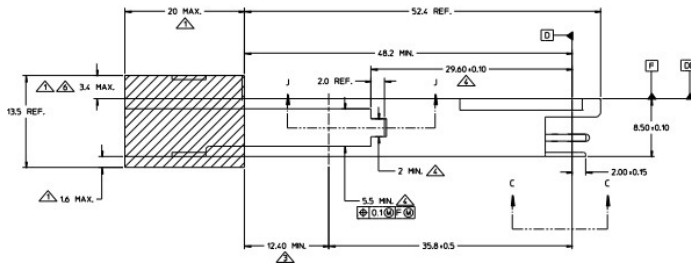

About AddOn Networks

In 1999, AddOn Networks entered the market with a single product. Our founders fulfilled a severe shortage for compatible, cost-effective optical transceivers that compete at the same performance levels as leading OEM manufacturers. Adhering to the idea of redefining service and product quality not previously had in the fiber optic networking industry, AddOn invested resources in solution design, production, fulfillment, and global support.

Combining one of the most extensive and stringent testing processes in the industry, an exceptional free tech support center, and a consistent roll-out of innovative technologies, AddOn has continually set industry standards of quality and reliability throughout its history.

Reliability is the cornerstone of any optical fiber network and is engrained in AddOn's DNA. It has played a key role in nurturing the long-term relationships developed over the years with customers. AddOn remains committed to exceeding industry standards with certifications from ranging from NEBS Level 3 to ISO 9001:2005 with every new development while maintaining the signature reliability of its products.



U.S. Headquarters

Email: sales@addonnetworks.com

Telephone: +1 877.292.1701

Fax: 949.266.9273

Europe Headquarters

Email: salesupportemea@addonnetworks.com

Telephone: +44 1285 842070