

FTL4C1QL2L-AO

Finisar® FTL4C1QL2L Compatible TAA Compliant 40GBase-IR4 QSFP+ Transceiver (SMF, 1270nm to 1330nm, 2km, LC, DOM)

Features

- SFF-8436 Compliance
- Duplex LC Connector
- Commercial Temperature 0 to 70 Celsius
- Single-mode Fiber
- Hot Pluggable
- Excellent ESD Protection
- Metal with Lower EMI
- RoHS Compliant and Lead Free



Applications

- 40GBase Ethernet
- Access and Enterprise

Product Description

This Finisar® FTL4C1QL2L compatible QSFP+ transceiver provides 40GBase-IR throughput up to 2km over single-mode fiber (SMF) using a wavelength of 1270nm to 1330nm via an LC connector. It is guaranteed to be 100% compatible with the equivalent Finisar® transceiver. This easy to install, hot swappable transceiver has been programmed, uniquely serialized and data-traffic and application tested to ensure that it will initialize and perform identically. Digital optical monitoring (DOM) support is also present to allow access to real-time operating parameters. This transceiver is Trade Agreements Act (TAA) compliant. We stand behind the quality of our products and proudly offer a limited lifetime warranty.

AddOn's transceivers are RoHS compliant and lead-free.

TAA refers to the Trade Agreements Act (19 U.S.C. & 2501-2581), which is intended to foster fair and open international trade. TAA requires that the U.S. Government may acquire only "U.S. – made or designated country end products."



Absolute Maximum Ratings

Parameter	Symbol	Min.	Typ.	Max.	Unit
Storage Temperature	TS	-40		85	°C
Operating Case Temperature	Tc	0		70	°C
Power Supply Voltage	Vcc	-0.5		3.6	V
Relative Humidity (non-condensation)	RH	0		85	%
Damage Threshold, each lane	THd	4.5			dBm
Link Distance with G.652	D			2	km
Data Rate, each lane			10.3125	11.2	Gbps

Electrical Characteristics

Parameter	Symbol	Min.	Typ.	Max.	Unit	Notes
Power Supply Voltage	Vcc	3.135	3.3	3.465	V	
Supply Current	ICC			1.1	A	
Control Input Voltage High		2		VCC	V	
Control Input Voltage Low		0		0.8	V	
Power Consumption				3.5	W	
Transceiver Power-on Initialization Time				2000	ms	1
Transmitter (each lane)						
Single-ended Input Voltage Tolerance (Note 2)		-0.3		4.0	V	Referred to TP1 signal common
AC Common Mode Input Voltage Tolerance		15			mV	RMS
Differential Input Voltage Swing Threshold		50			mVpp	LOSA Threshold
Differential Input Voltage Swing	Vin,pp	190		700	mVpp	
Differential Input Impedance	Zin	90	100	110	Ohm	
Differential Input Return Loss	See IEEE 802.3ba 86A.4.11				dB	10MHz-11.1GHz
J2 Jitter tolerance	Jt2	0.17			UI	
J9 Jitter Tolerance	Jt9	0.29			UI	
Data Dependent Pulse Width Shrinkage Tolerance	DDPWS	0.07			UI	
Eye Mask Coordinates {X1, X2, Y1, Y2}	0.1, 0.31, 95, 350				UI, mV	Hit Ratio = 5×10^{-5}
Receiver (each lane)						
Single Ended Output Voltage		-0.3		4.0	V	Referred to signal common
AC Common Mode Output Voltage				7.5	mV	RMS
Differential Output Voltage Swing	Vout,pp	300		850	mVpp	
Differential Output Impedance	Zout	90	100	110	Ohm	
Termination Mismatch at 1MHz				5	%	
Differential Output Return Loss	See IEEE 802.3ba 86A.4.2.1				dB	10MHz-11.1GHz
Common-mode Output Return Loss	See IEEE 802.3ba 86A.4.2.2				dB	10MHz-11.1GHz
Output Transition Time		28			ps	20% to 80%
J2 Jitter Output	Jo2			0.42	UI	
J9 Jitter Output	Jo9			0.65	UI	
Eye Mask Coordinates {X1, X2, Y1, Y2}	0.29, 0.5, 150, 425				UI, mV	Hit Ratio = 5×10^{-5}

Notes:

1. Power-on Initialization Time is the time from when the power supply voltages reach and remain above the minimum recommended operating supply voltages to the time when the module is fully functional.
2. The single ended input voltage tolerance is the allowable range of the instantaneous input signals.

Optical Characteristics

Parameter	Symbol	Min.	Typ.	Max.	Unit	Notes
Wavelength	L0	1264.5	1271	1277.5	nm	
	L1	1284.5	1291	1297.5	nm	
	L2	1304.5	1311	1317.5	nm	
	L3	1324.5	1331	1337.5	nm	
Transmitter						
Side-mode Suppression Ratio	SMSR	30			dB	
Total Average Launch Power	P _T			8.3	dBm	
Average Launch Power, each Lane		-7.0		2.3	dBm	
Optical Modulation Amplitude, each Lane	POMA	-6.0		3.5	dBm	1
Difference in launch Power between any two lanes (OMA)	P _{tx, diff}			6.5	dB	
Launch Power in OMA minus Transmitter and Dispersion Penalty (TDP), each Lane		-6.8			dBm	
TDP, each Lane	TDP			2.6	dB	
Extinction Ratio	ER	3.5			dB	
Relative Intensity Noise	R _{in}			-128	dB/Hz	2
Optical Return Loss Tolerance	TOL			20	dB	
Transmitter Reflectance	R _T			-12	dB	
Transmitter Eye Mask Definition {X1, X2, X3, Y1, Y2, Y3}	{0.25, 0.4, 0.45, 0.25, 0.28, 0.4}					
Average Launch Power OFF Transmitter, each Lane	P _{off}			-30	dBm	
Receiver						
Damage Threshold, each lane	TH _d	4.5			dBm	3
Total Average Receive Power				8.3	dBm	
Average Receive Power, each Lane		-11.7		2.3	dBm	
Receiver Reflectance	R _R			-26	dB	
Receive Power (OMA), each Lane				3.5	dBm	
Receiver Sensitivity (OMA), each Lane	SEN			-11.5	dBm	
Difference in Receive Power between any Two Lanes (OMA)				7.5	dB	
LOS Assert	LOSA	-28			dBm	
LOS Deassert	LOSD			-15	dBm	
LOS Hysteresis	LOSH	0.5			dB	
Receiver Electrical 3dB upper Cut-off Frequency, each Lane				12.3	GHz	

Notes:

1. Even if the TDP < 0.8 dB, the OMA min must exceed the minimum value specified here.
2. 12dB reflection
3. The receiver shall be able to tolerate, without damage, continuous exposure to a modulated optical input signal having this power level on one lane. The receiver does not have to operate correctly at this input power.

Pin Descriptions

Pin	Logic	Symbol	Name/Descriptions	Ref.
1		GND	Ground	1
2	CML-I	Tx2n	Transmitter Inverted Data Input	
3	CML-I	Tx2p	Transmitter Non-Inverted Data output	
4		GND	Ground	1
5	CML-I	Tx4n	Transmitter Inverted Data Input	
6	CML-I	Tx4p	Transmitter Non-Inverted Data output	
7		GND	Ground	1
8	LVTTLL-I	ModSelL	Module Select	
9	LVTTLL-I	ResetL	Module Reset	
10		VccRx	+3.3V Power Supply Receiver	2
11	LVC MOS-I/O	SCL	2-Wire Serial Interface Clock	
12	LVC MOS-I/O	SDA	2-Wire Serial Interface Data	
13		GND	Ground	
14	CML-O	Rx3p	Receiver Non-Inverted Data Output	
15	CML-O	Rx3n	Receiver Inverted Data Output	
16		GND	Ground	1
17	CML-O	Rx1p	Receiver Non-Inverted Data Output	
18	CML-O	Rx1n	Receiver Inverted Data Output	
19		GND	Ground	1
20		GND	Ground	1
21	CML-O	Rx2n	Receiver Inverted Data Output	
22	CML-O	Rx2p	Receiver Non-Inverted Data Output	
23		GND	Ground	1
24	CML-O	Rx4n	Receiver Inverted Data Output	1
25	CML-O	Rx4p	Receiver Non-Inverted Data Output	
26		GND	Ground	1
27	LVTTTL-O	ModPrsL	Module Present	
28	LVTTTL-O	IntL	Interrupt	
29		VccTx	+3.3 V Power Supply transmitter	2
30		Vcc1	+3.3 V Power Supply	2
31	LVTTTL-I	LPMode	Low Power Mode	
32		GND	Ground	1
33	CML-I	Tx3p	Transmitter Non-Inverted Data Input	
34	CML-I	Tx3n	Transmitter Inverted Data Output	
35		GND	Ground	1
36	CML-I	Tx1p	Transmitter Non-Inverted Data Input	
37	CML-I	Tx1n	Transmitter Inverted Data Output	
38		GND	Ground	1

Notes:

1. GND is the symbol for signal and supply (power) common for QSFP+ modules. All are common within the QSFP+ module and all module voltages are referenced to this potential unless otherwise noted. Connect these directly to the host board signal common ground plane.
2. VccRx, Vcc1 and VccTx are the receiving and transmission power suppliers and shall be applied concurrently. Recommended host board power supply filtering is shown in Figure 3 below. Vcc Rx, Vcc1 and Vcc Tx may be internally connected within the QSFP+ transceiver module in any combination. The connector pins are each rated for a maximum current of 500mA.

Electrical Pin-out Details

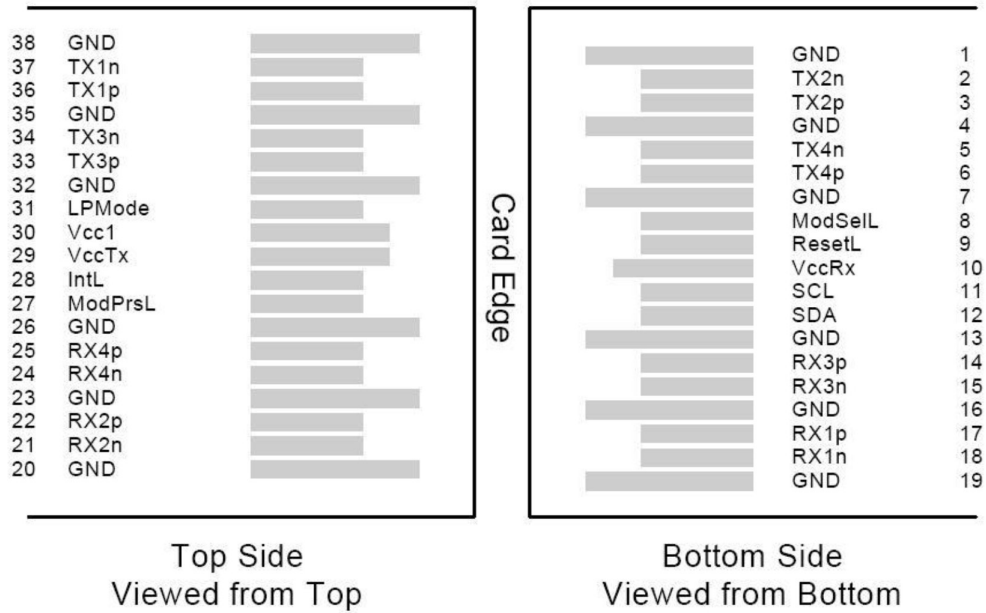

Recommended Power Supply Filter

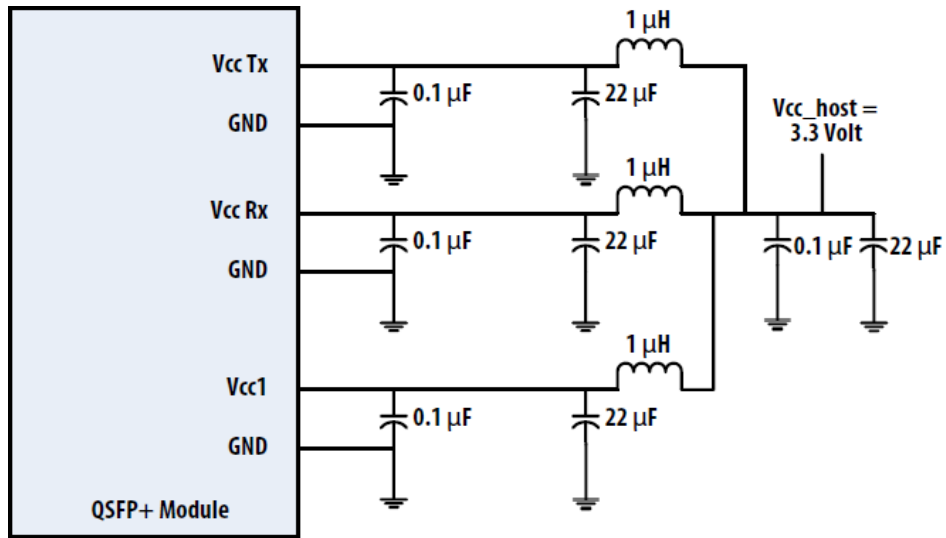

Mechanical Specifications

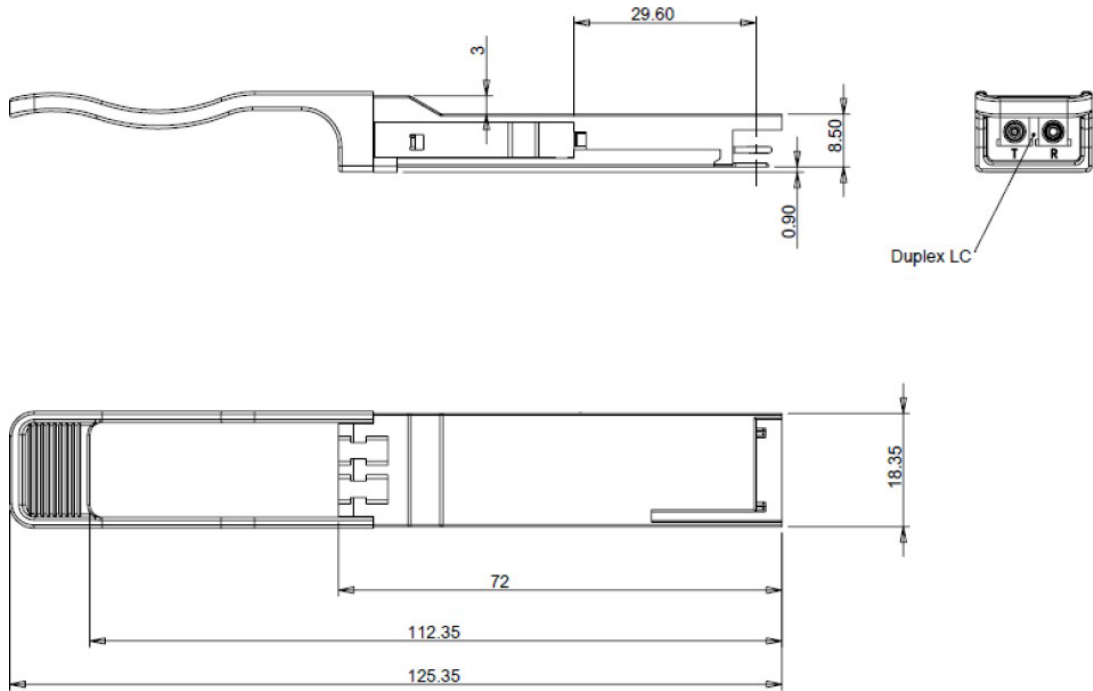

Digital Diagnostic Functions

The following digital diagnostic characteristics are defined over the normal operating conditions unless otherwise specified.

Parameter	Symbol	Min	Max	Units	Notes
Temperature monitor absolute error	DMI_Temp	-3	3	°C	Over operating temperature range
Supply voltage monitor absolute error	DMI_VCC	-0.1	0.1	V	Over full operating range
Channel RX power monitor absolute error	DMI_RX_Ch	-2	2	dB	1
Channel Bias current monitor	DMI_Ibias_Ch	-10%	10%	mA	
Channel TX power monitor absolute error	DMI_TX_Ch	-2	2	dB	1

Notes:

1. Due to measurement accuracy of different single mode fibers, there could be an additional +/-1 dB fluctuation, or a +/- 3 dB total accuracy.

About AddOn Networks

In 1999, AddOn Networks entered the market with a single product. Our founders fulfilled a severe shortage for compatible, cost-effective optical transceivers that compete at the same performance levels as leading OEM manufacturers. Adhering to the idea of redefining service and product quality not previously had in the fiber optic networking industry, AddOn invested resources in solution design, production, fulfillment, and global support.

Combining one of the most extensive and stringent testing processes in the industry, an exceptional free tech support center, and a consistent roll-out of innovative technologies, AddOn has continually set industry standards of quality and reliability throughout its history.

Reliability is the cornerstone of any optical fiber network and is engrained in AddOn's DNA. It has played a key role in nurturing the long-term relationships developed over the years with customers. AddOn remains committed to exceeding industry standards with certifications from ranging from NEBS Level 3 to ISO 9001:2005 with every new development while maintaining the signature reliability of its products.



U.S. Headquarters

Email: sales@addonnetworks.com

Telephone: +1 877.292.1701

Fax: 949.266.9273

Europe Headquarters

Email: salesupportemea@addonnetworks.com

Telephone: +44 1285 842070