

OptiPlex 5000 Small Form Factor

Service Manual

Notes, cautions, and warnings

 **NOTE:** A NOTE indicates important information that helps you make better use of your product.

 **CAUTION:** A CAUTION indicates either potential damage to hardware or loss of data and tells you how to avoid the problem.

 **WARNING:** A WARNING indicates a potential for property damage, personal injury, or death.

Chapter 1: Working inside your computer	6
Safety instructions.....	6
Before working inside your computer.....	6
Safety precautions.....	7
Electrostatic discharge—ESD protection.....	7
ESD field service kit	8
Transporting sensitive components.....	9
After working inside your computer.....	9
Chapter 2: Removing and installing components	10
Recommended tools.....	10
Screw list.....	10
Customer Replaceable Units (CRU) and Field Replaceable Units (FRU) list.....	11
Major components of OptiPlex 5000 Small Form Factor.....	12
Side cover.....	14
Removing the side cover.....	14
Installing the side cover.....	15
Front bezel.....	16
Removing the front bezel.....	16
Installing the front bezel.....	17
Intrusion switch.....	18
Removing the intrusion switch.....	18
Installing the intrusion switch.....	19
Hard drive.....	20
Removing the 2.5-inch hard drive.....	20
Installing the 2.5-inch hard drive.....	22
Removing the 3.5-inch hard drive.....	24
Installing the 3.5-inch hard drive.....	26
Hard-drive and optical-drive bracket.....	27
Removing the hard-drive and optical-drive bracket.....	27
Installing the hard-drive and optical-drive bracket.....	29
Optical drive.....	31
Removing the optical drive.....	31
Installing the optical-drive.....	33
Solid-state drive.....	35
Removing the M.2 2230 solid-state drive.....	35
Installing the M.2 2230 solid-state drive.....	36
Removing the M.2 2280 solid-state drive.....	36
Installing the M.2 2280 solid-state drive.....	37
Removing and installing the M.2 screw mount.....	38
Hard-drive and optical-drive supporting bracket.....	39
Removing the hard-drive and optical-drive supporting bracket.....	39
Installing the hard-drive and optical-drive supporting bracket.....	40
SD-card reader.....	41











Removing the SD-card reader.....	41
Installing the SD-card reader.....	42
Coin-cell battery.....	43
Removing the coin-cell battery.....	43
Installing the coin-cell battery.....	44
Power button.....	45
Removing the power button.....	45
Installing the power button.....	46
WLAN card.....	47
Removing the WLAN card.....	47
Installing the WLAN card.....	48
WLAN antenna.....	50
Removing the internal WLAN antenna.....	50
Installing the WLAN antenna.....	51
WLAN antennas (External).....	52
Removing the external WLAN antenna.....	52
Installing the external WLAN antenna.....	53
Memory.....	55
Removing the memory.....	55
Installing the memory.....	56
Processor fan and heat-sink assembly.....	57
Removing the processor fan and heat-sink assembly.....	57
Installing the processor fan and heat-sink assembly.....	58
Voltage regulator heat sink.....	59
Removing the voltage-regulator heat sink.....	59
Installing the voltage-regulator heat sink.....	60
Processor.....	61
Removing the processor.....	61
Installing the processor.....	62
Expansion card.....	63
Removing the graphics card.....	63
Installing the graphics card.....	65
Removing the Dell Ultra Speed Drive Gen 4 card.....	66
Installing the Dell Ultra Speed Drive Gen 4 card.....	66
Optional I/O modules (PS2/Serial).....	67
Removing optional PS2 module.....	67
Installing optional PS2 module.....	69
Optional I/O modules (VGA/HDMI/DP/USB Type-C).....	70
Removing optional I/O module.....	70
Installing optional I/O module.....	71
Chassis fan.....	72
Removing the chassis fan.....	72
Installing the chassis fan.....	73
Speakers.....	73
Removing the speaker.....	73
Installing the speaker.....	74
Power-supply unit.....	75
Removing the power-supply unit.....	75
Installing the power-supply unit.....	77
System board.....	78

System board callouts - 5000 Small Form Factor.....	78
Removing the system board.....	79
Installing the system board.....	83
Chapter 3: Drivers and downloads.....	88
Chapter 4: Getting help and contacting Dell.....	89

Working inside your computer

Safety instructions

Use the following safety guidelines to protect your computer from potential damage and to ensure your personal safety. Unless otherwise noted, each procedure included in this document assumes that you have read the safety information that shipped with your computer.

-  **WARNING:** Before working inside your computer, read the safety information that is shipped with your computer. For more safety best practices, see the Regulatory Compliance home page at www.dell.com/regulatory_compliance.
-  **WARNING:** Disconnect your computer from all power sources before opening the computer cover or panels. After you finish working inside the computer, replace all covers, panels, and screws before connecting your computer to an electrical outlet.
-  **CAUTION:** To avoid damaging the computer, ensure that the work surface is flat, dry, and clean.
-  **CAUTION:** To avoid damaging the components and cards, handle them by their edges, and avoid touching the pins and the contacts.
-  **CAUTION:** You should only perform troubleshooting and repairs as authorized or directed by the Dell technical assistance team. Damage due to servicing that is not authorized by Dell is not covered by your warranty. See the safety instructions that is shipped with the product or at www.dell.com/regulatory_compliance.
-  **CAUTION:** Before touching anything inside your computer, ground yourself by touching an unpainted metal surface, such as the metal at the back of the computer. While you work, periodically touch an unpainted metal surface to dissipate static electricity which could harm internal components.
-  **CAUTION:** When you disconnect a cable, pull it by its connector or its pull tab, not the cable itself. Some cables have connectors with locking tabs or thumbscrews that you must disengage before disconnecting the cable. When disconnecting cables, keep them evenly aligned to avoid bending the connector pins. When connecting cables, ensure that the ports and the connectors are correctly oriented and aligned.
-  **CAUTION:** Press and eject any installed card from the media-card reader.
-  **CAUTION:** Exercise caution when handling Lithium-ion batteries in laptops. Swollen batteries should not be used and should be replaced and disposed properly.
-  **NOTE:** The color of your computer and certain components may appear differently than shown in this document.

Before working inside your computer

About this task

-  **NOTE:** The images in this document may differ from your computer depending on the configuration you ordered.

Steps

1. Save and close all open files and exit all open applications.
2. Shut down your computer. Click **Start** >  **Power** > **Shut down**.

 **NOTE:** If you are using a different operating system, see the documentation of your operating system for shut-down instructions.

3. Disconnect your computer and all attached devices from their electrical outlets.
4. Disconnect all attached network devices and peripherals, such as keyboard, mouse, and monitor from your computer.

 **CAUTION:** To disconnect a network cable, first unplug the cable from your computer and then unplug the cable from the network device.

5. Remove any media card and optical disc from your computer, if applicable.

Safety precautions

The safety precautions chapter details the primary steps to be taken before performing any disassembly instructions.

Observe the following safety precautions before you perform any installation or break/fix procedures involving disassembly or reassembly:

- Turn off the system and all attached peripherals.
- Disconnect the system and all attached peripherals from AC power.
- Disconnect all network cables, telephone, and telecommunications lines from the system.
- Use an ESD field service kit when working inside any desktop to avoid electrostatic discharge (ESD) damage.
- After removing any system component, carefully place the removed component on an anti-static mat.
- Wear shoes with non-conductive rubber soles to reduce the chance of getting electrocuted.

Standby power

Dell products with standby power must be unplugged before you open the case. Systems that incorporate standby power are essentially powered while turned off. The internal power enables the system to be remotely turned on (wake on LAN) and suspended into a sleep mode and has other advanced power management features.

Unplugging, pressing and holding the power button for 15 seconds should discharge residual power in the system board.

Bonding

Bonding is a method for connecting two or more grounding conductors to the same electrical potential. This is done through the use of a field service electrostatic discharge (ESD) kit. When connecting a bonding wire, ensure that it is connected to bare metal and never to a painted or non-metal surface. The wrist strap should be secure and in full contact with your skin, and ensure that you remove all jewelry such as watches, bracelets, or rings prior to bonding yourself and the equipment.

Electrostatic discharge—ESD protection

ESD is a major concern when you handle electronic components, especially sensitive components such as expansion cards, processors, memory DIMMs, and system boards. Very slight charges can damage circuits in ways that may not be obvious, such as intermittent problems or a shortened product life span. As the industry pushes for lower power requirements and increased density, ESD protection is an increasing concern.

Due to the increased density of semiconductors used in recent Dell products, the sensitivity to static damage is now higher than in previous Dell products. For this reason, some previously approved methods of handling parts are no longer applicable.

Two recognized types of ESD damage are catastrophic and intermittent failures.

- **Catastrophic** – Catastrophic failures represent approximately 20 percent of ESD-related failures. The damage causes an immediate and complete loss of device functionality. An example of catastrophic failure is a memory DIMM that has received a static shock and immediately generates a "No POST/No Video" symptom with a beep code emitted for missing or nonfunctional memory.
- **Intermittent** – Intermittent failures represent approximately 80 percent of ESD-related failures. The high rate of intermittent failures means that most of the time when damage occurs, it is not immediately recognizable. The DIMM receives a static shock, but the tracing is merely weakened and does not immediately produce outward symptoms related to the damage. The weakened trace may take weeks or months to melt, and in the meantime may cause degradation of memory integrity, intermittent memory errors, etc.

The more difficult type of damage to recognize and troubleshoot is the intermittent (also called latent or "walking wounded") failure.

Perform the following steps to prevent ESD damage:

- Use a wired ESD wrist strap that is properly grounded. The use of wireless anti-static straps is no longer allowed; they do not provide adequate protection. Touching the chassis before handling parts does not ensure adequate ESD protection on parts with increased sensitivity to ESD damage.
- Handle all static-sensitive components in a static-safe area. If possible, use anti-static floor pads and workbench pads.
- When unpacking a static-sensitive component from its shipping carton, do not remove the component from the anti-static packing material until you are ready to install the component. Before unwrapping the anti-static packaging, ensure that you discharge static electricity from your body.
- Before transporting a static-sensitive component, place it in an anti-static container or packaging.

ESD field service kit

The unmonitored Field Service kit is the most commonly used service kit. Each Field Service kit includes three main components: anti-static mat, wrist strap, and bonding wire.

Components of an ESD field service kit

The components of an ESD field service kit are:

- **Anti-Static Mat** – The anti-static mat is dissipative and parts can be placed on it during service procedures. When using an anti-static mat, your wrist strap should be snug and the bonding wire should be connected to the mat and to any bare metal on the system being worked on. Once deployed properly, service parts can be removed from the ESD bag and placed directly on the mat. ESD-sensitive items are safe in your hand, on the ESD mat, in the system, or inside a bag.
- **Wrist Strap and Bonding Wire** – The wrist strap and bonding wire can be either directly connected between your wrist and bare metal on the hardware if the ESD mat is not required, or connected to the anti-static mat to protect hardware that is temporarily placed on the mat. The physical connection of the wrist strap and bonding wire between your skin, the ESD mat, and the hardware is known as bonding. Use only Field Service kits with a wrist strap, mat, and bonding wire. Never use wireless wrist straps. Always be aware that the internal wires of a wrist strap are prone to damage from normal wear and tear, and must be checked regularly with a wrist strap tester in order to avoid accidental ESD hardware damage. It is recommended to test the wrist strap and bonding wire at least once per week.
- **ESD Wrist Strap Tester** – The wires inside of an ESD strap are prone to damage over time. When using an unmonitored kit, it is a best practice to regularly test the strap prior to each service call, and at a minimum, test once per week. A wrist strap tester is the best method for doing this test. If you do not have your own wrist strap tester, check with your regional office to find out if they have one. To perform the test, plug the wrist-strap's bonding-wire into the tester while it is strapped to your wrist and push the button to test. A green LED is lit if the test is successful; a red LED is lit and an alarm sounds if the test fails.
- **Insulator Elements** – It is critical to keep ESD sensitive devices, such as plastic heat sink casings, away from internal parts that are insulators and often highly charged.
- **Working Environment** – Before deploying the ESD Field Service kit, assess the situation at the customer location. For example, deploying the kit for a server environment is different than for a desktop or portable environment. Servers are typically installed in a rack within a data center; desktops or portables are typically placed on office desks or cubicles. Always look for a large open flat work area that is free of clutter and large enough to deploy the ESD kit with additional space to accommodate the type of system that is being repaired. The workspace should also be free of insulators that can cause an ESD event. On the work area, insulators such as Styrofoam and other plastics should always be moved at least 12 inches or 30 centimeters away from sensitive parts before physically handling any hardware components
- **ESD Packaging** – All ESD-sensitive devices must be shipped and received in static-safe packaging. Metal, static-shielded bags are preferred. However, you should always return the damaged part using the same ESD bag and packaging that the new part arrived in. The ESD bag should be folded over and taped shut and all the same foam packing material should be used in the original box that the new part arrived in. ESD-sensitive devices should be removed from packaging only at an ESD-protected work surface, and parts should never be placed on top of the ESD bag because only the inside of the bag is shielded. Always place parts in your hand, on the ESD mat, in the system, or inside an anti-static bag.
- **Transporting Sensitive Components** – When transporting ESD sensitive components such as replacement parts or parts to be returned to Dell, it is critical to place these parts in anti-static bags for safe transport.

ESD protection summary

It is recommended that all field service technicians use the traditional wired ESD grounding wrist strap and protective anti-static mat at all times when servicing Dell products. In addition, it is critical that technicians keep sensitive parts separate from all insulator parts while performing service and that they use anti-static bags for transporting sensitive components.

Transporting sensitive components

When transporting ESD sensitive components such as replacement parts or parts to be returned to Dell, it is critical to place these parts in anti-static bags for safe transport.

Lifting equipment

Adhere to the following guidelines when lifting heavy weight equipment:

 **CAUTION: Do not lift greater than 50 pounds. Always obtain additional resources or use a mechanical lifting device.**

1. Get a firm balanced footing. Keep your feet apart for a stable base, and point your toes out.
2. Tighten stomach muscles. Abdominal muscles support your spine when you lift, offsetting the force of the load.
3. Lift with your legs, not your back.
4. Keep the load close. The closer it is to your spine, the less force it exerts on your back.
5. Keep your back upright, whether lifting or setting down the load. Do not add the weight of your body to the load. Avoid twisting your body and back.
6. Follow the same techniques in reverse to set the load down.

After working inside your computer

About this task

 **CAUTION: Leaving stray or loose screws inside your computer may severely damage your computer.**

Steps

1. Replace all screws and ensure that no stray screws remain inside your computer.
2. Connect any external devices, peripherals, or cables you removed before working on your computer.
3. Replace any media cards, discs, or any other parts that you removed before working on your computer.
4. Connect your computer and all attached devices to their electrical outlets.
5. Turn on your computer.

Removing and installing components

NOTE: The images in this document may differ from your computer depending on the configuration you ordered.

Recommended tools

The procedures in this document may require the following tools:

- Phillips screwdriver #0
- Phillips screwdriver #1
- Torx #5 (T5) screwdriver
- Plastic scribe

Screw list

NOTE: When removing screws from a component, it is recommended to note the screw type, the quantity of screws, and then place them in a screw storage box. This is to ensure that the correct number of screws and correct screw type is restored when the component is replaced.

NOTE: Some computers have magnetic surfaces. Ensure that the screws are not left attached to such surfaces when replacing a component.

NOTE: Screw color may vary with the configuration ordered.

Table 1. Screw list









Component	Screw type	Quantity	Screw image
Solid-state drive	M2x3	1	
Hard-drive and optical-drive supporting bracket	#6-32	2	
SD-card reader	M3x5	1	
WLAN card	M2x3	1	
Processor-fan and heat-sink assembly	Captive	4	
Voltage-regulator heat-sink	Captive	4	
Power supply unit	#6-32	3	

Table 1. Screw list (continued)

Component	Screw type	Quantity	Screw image
System board	#6-32	5	

Customer Replaceable Units (CRU) and Field Replaceable Units (FRU) list

Table 2. CRU/FRU list















































OptiPlex 5000 Small Form Factor	CRU component	FRU component
Side cover		
Front bezel		
Intrusion switch		
2.5-inch hard drive		
3.5-inch hard drive		
Optical drive		
Hard-drive and optical-drive bracket		
Supporting bracket		
M.2 Solid-state drive		
WLAN card		
Memory module		
Expansion card		
Heat-sink and fan assembly		

Table 2. CRU/FRU list (continued)

OptiPlex 5000 Small Form Factor	CRU component	FRU component
SD-card reader		
Optional I/O module (PS2/Serial)		
Coin-cell battery		
System fan		
Speaker		
VR heat-sink		
Power button		
Power supply unit		
Processor		
System board		

Major components of OptiPlex 5000 Small Form Factor

The following image shows the major components of OptiPlex 5000 Small Form Factor.

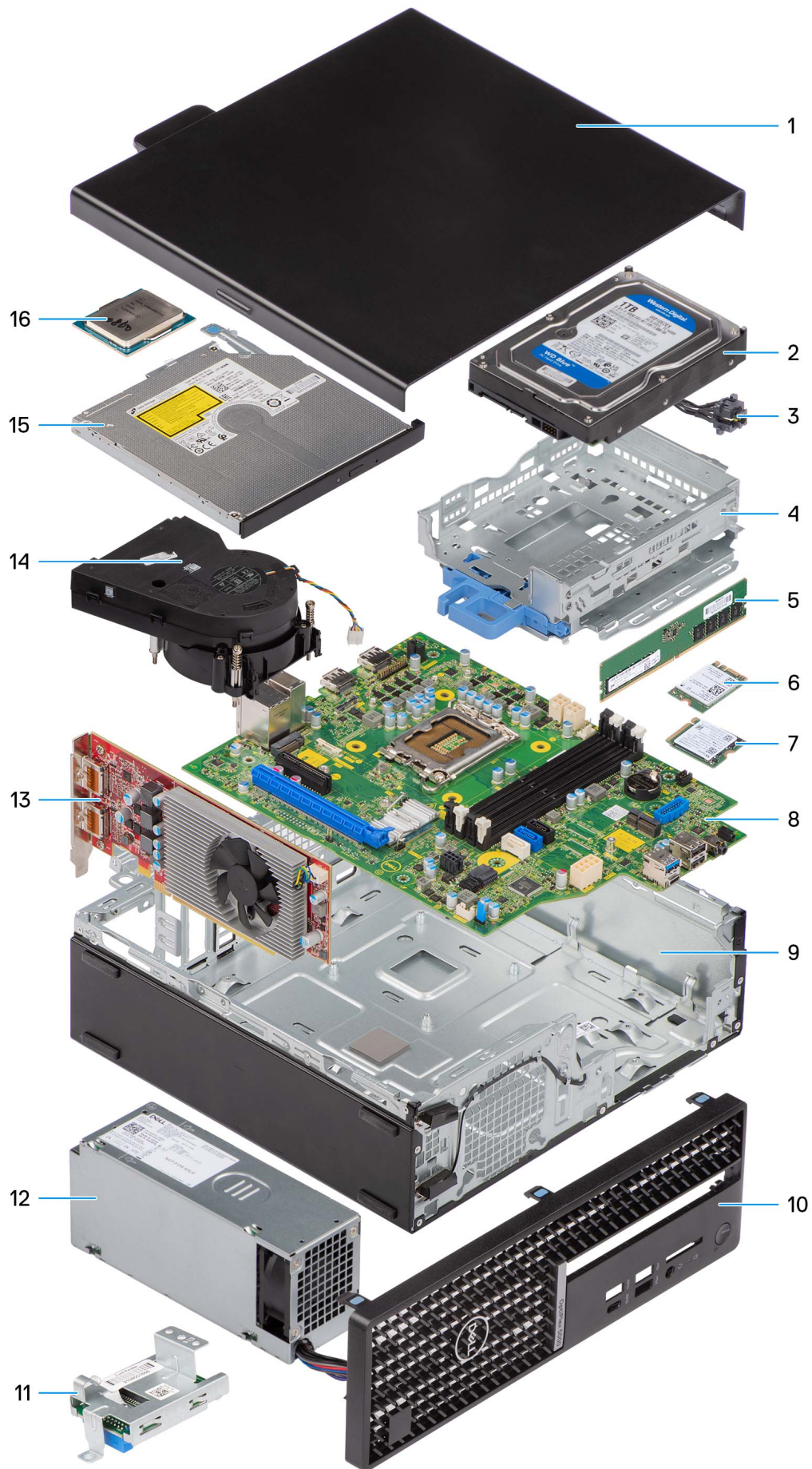

1. Side cover
2. Hard-drive assembly
3. Power button
4. Hard-drive and optical-drive bracket
5. Memory module
6. WLAN card
7. M.2 Solid-state drive
8. System board
9. Chassis
10. Front bezel
11. SD-card reader
12. Power supply unit
13. Expansion card
14. Heat-sink and fan assembly
15. Optical drive
16. Processor

NOTE: Dell provides a list of components and their part numbers for the original system configuration purchased. These parts are available according to warranty coverages purchased by the customer. Contact your Dell sales representative for purchase options.

Side cover

Removing the side cover

Prerequisites

1. Follow the procedure in [before working inside your computer](#).

NOTE: Ensure that you remove the security cable from the security-cable slot (if applicable).

About this task

The following images indicate the location of the side cover and provide a visual representation of the removal procedure.

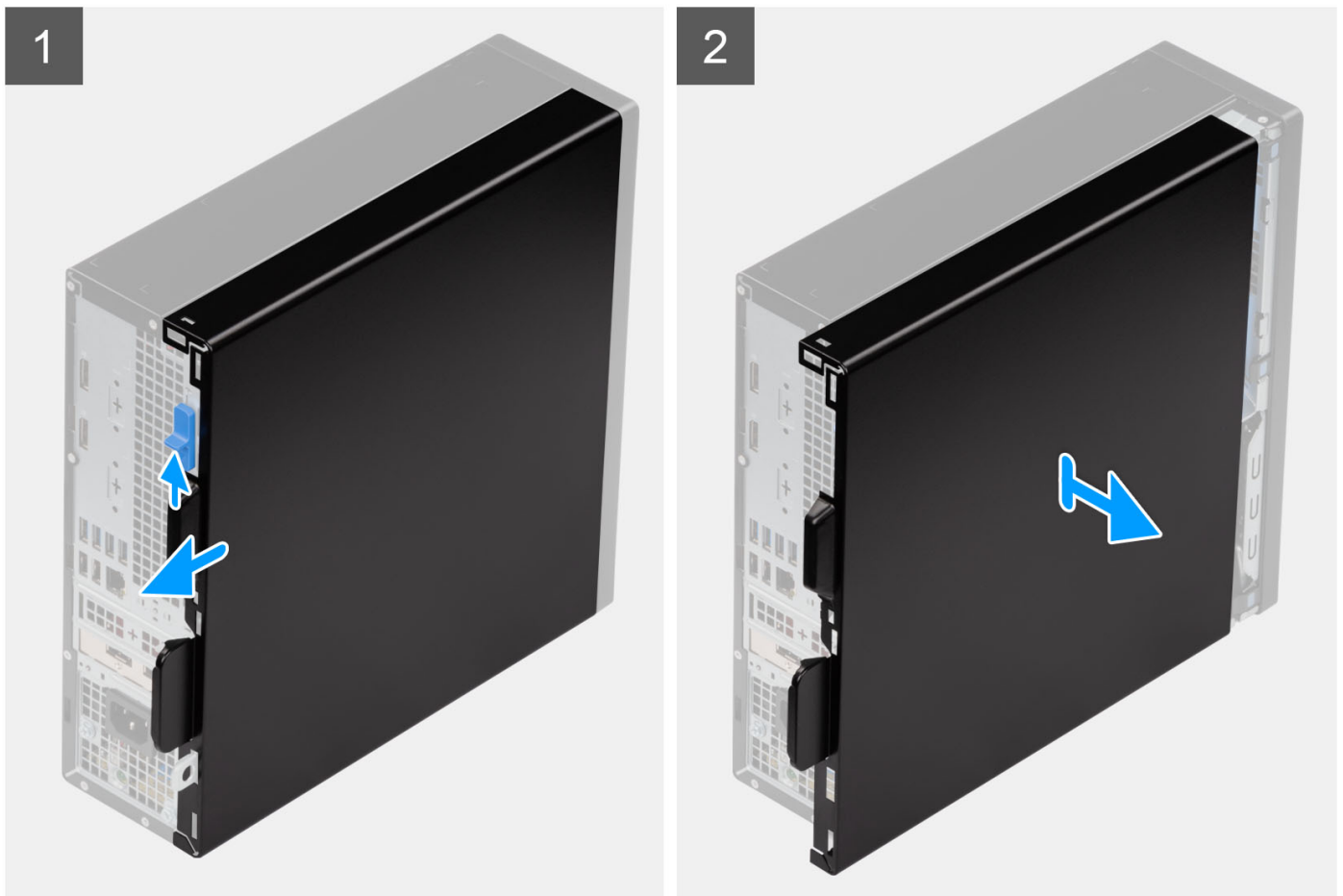

Steps

1. Slide the release latch until you hear a click and slide the side cover towards the back of the computer.
2. Lift the side cover from the chassis.

Installing the side cover

Prerequisites

If you are replacing a component, remove the existing component before performing the installation procedure.

About this task

The following images indicate the location of the side cover and provide a visual representation of the installation procedure.

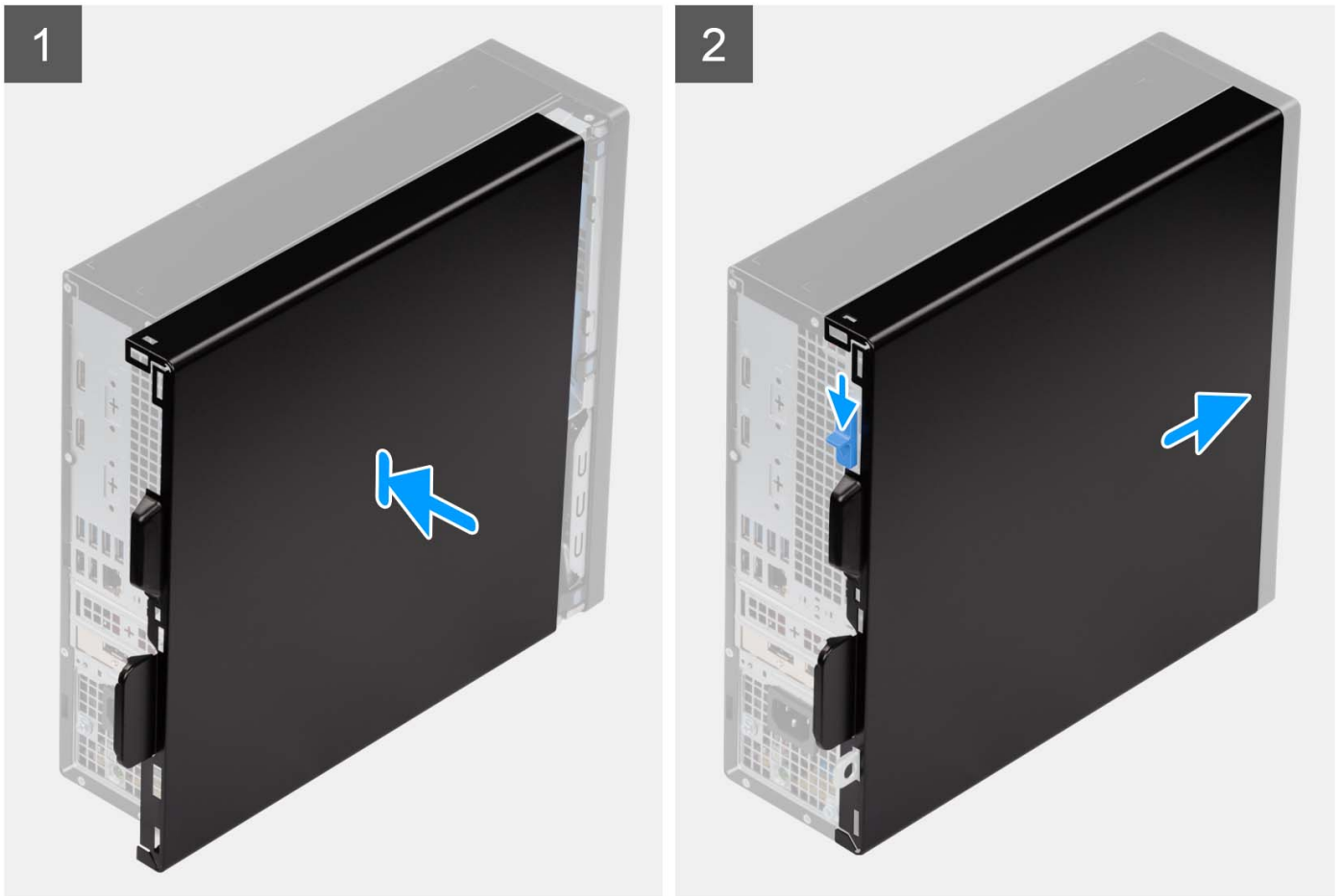

Steps

1. Align the tabs on the side cover with the slots on the chassis.
2. Slide the side cover towards the front of the computer until you hear the release latch click.

Next steps

1. Follow the procedure in [after working inside your computer](#).

Front bezel

Removing the front bezel

Prerequisites

1. Follow the procedure in [before working inside your computer](#).
2. Remove the [side cover](#).

About this task

The following images indicate the location of the front bezel and provide a visual representation of the removal procedure.

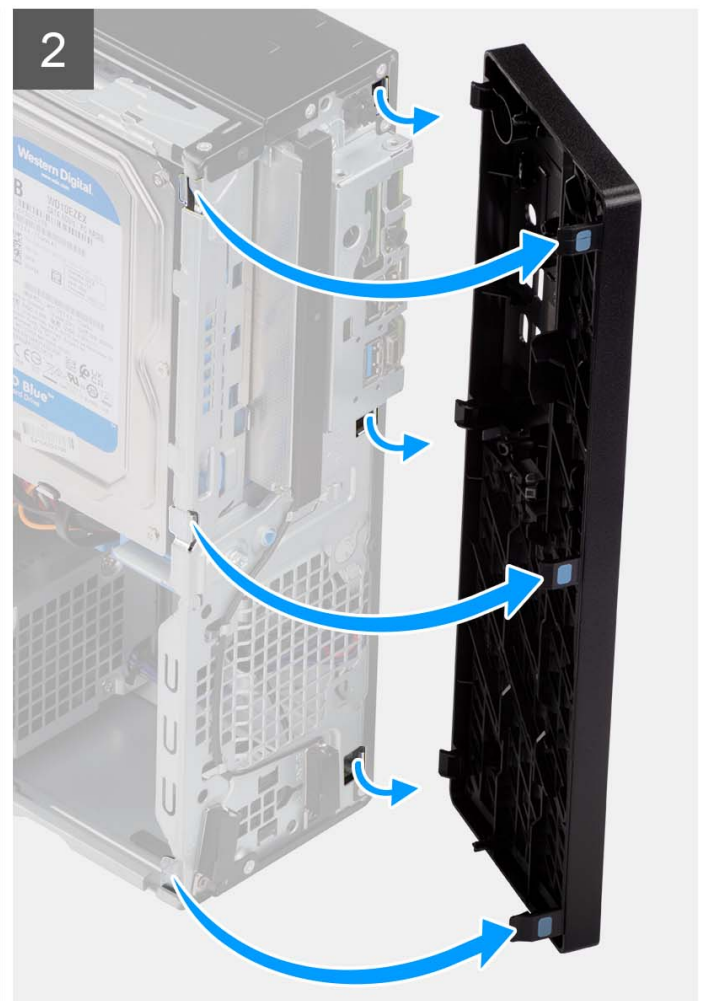

Steps

1. Gently pry and release the front-bezel tabs sequentially from the top.
2. Rotate the front bezel outwards, away from the chassis, and remove the front bezel.

Installing the front bezel

Prerequisites

If you are replacing a component, remove the existing component before performing the installation procedure.

About this task

The following images indicate the location of the front bezel and provide a visual representation of the installation procedure.

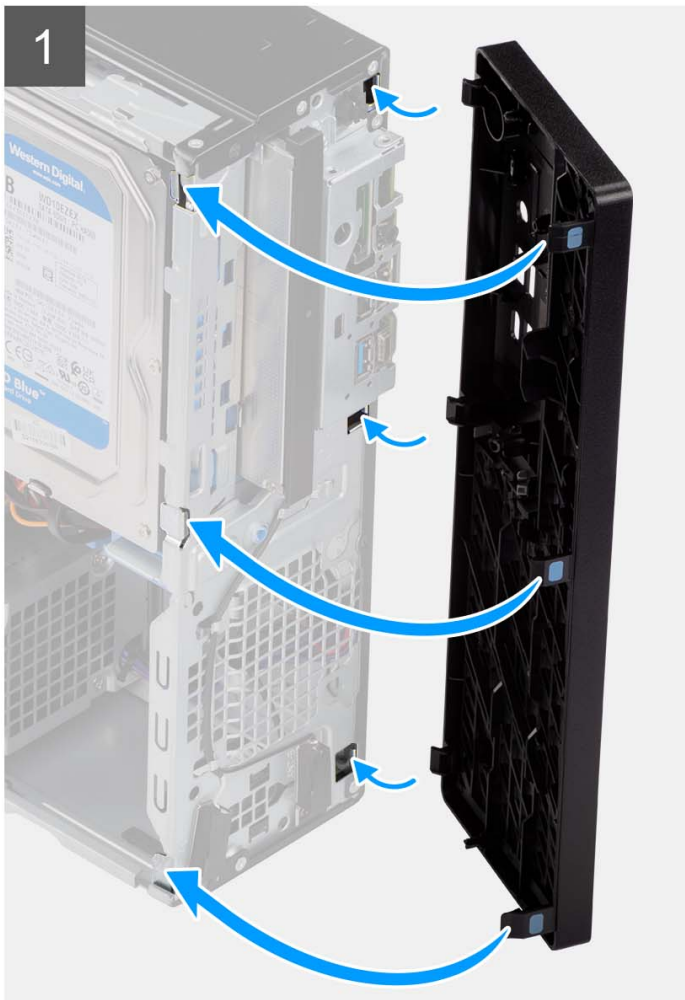

Steps

1. Align and insert the front-bezel tabs with the slots on the chassis.
2. Rotate the front bezel towards the chassis and snap it into place.

Next steps

1. Install the [side cover](#).
2. Follow the procedure in [after working inside your computer](#).

Intrusion switch

Removing the intrusion switch

Prerequisites

1. Follow the procedure in [before working inside your computer](#).
2. Remove the [side cover](#).

About this task

The following images indicate the location of the intrusion switch and provide a visual representation of the removal procedure.

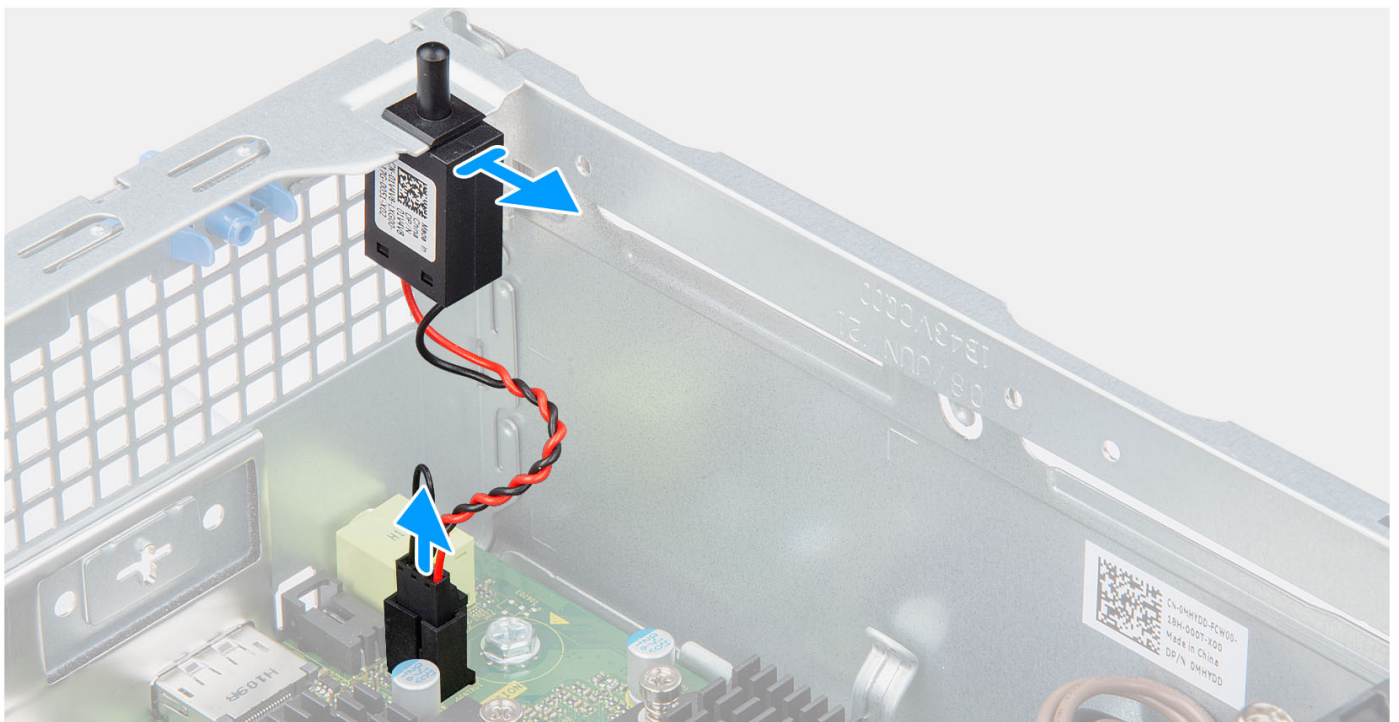

Steps

1. Disconnect the intrusion-switch cable from the connector on the system board.
2. Slide the intrusion switch and lift it away from the computer.

Installing the intrusion switch

Prerequisites

If you are replacing a component, remove the existing component before performing the installation procedure.

About this task

The following images indicate the location of the intrusion switch and provide a visual representation of the installation procedure.

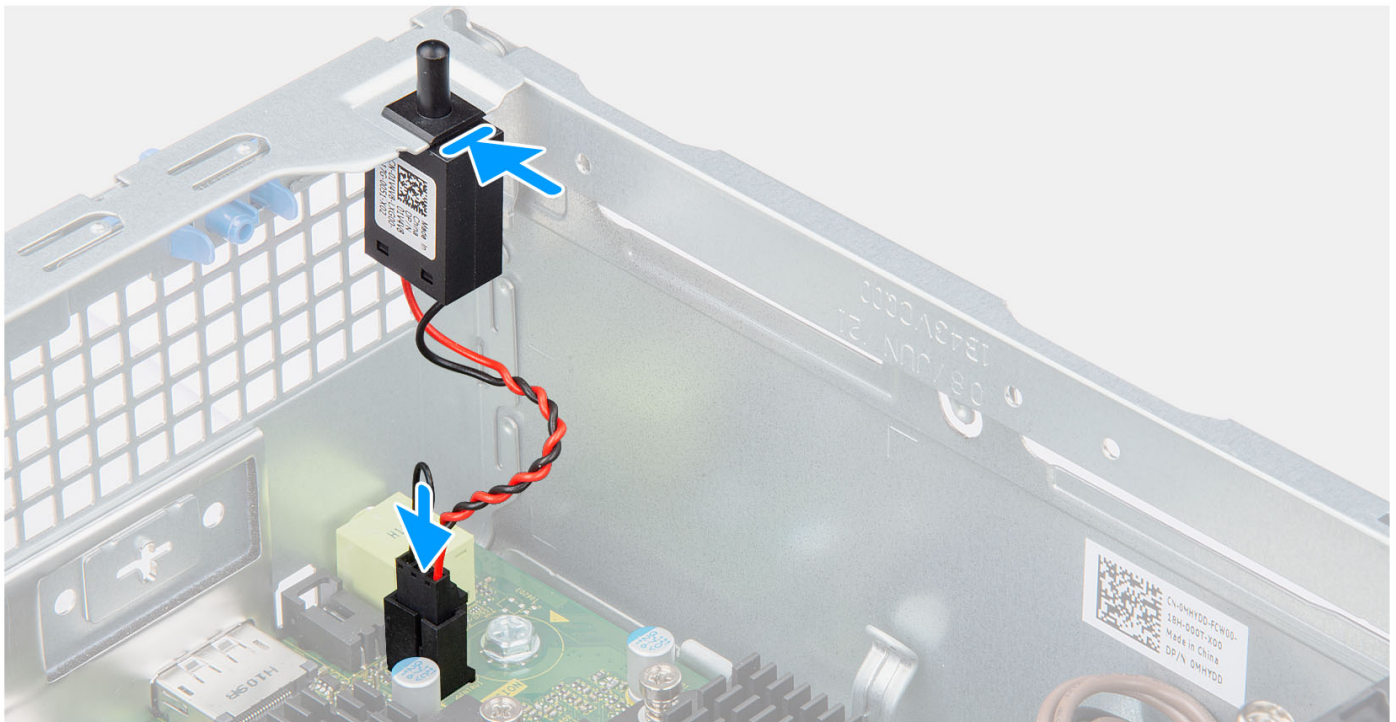

Steps

1. Slide the intrusion switch into the slot on the chassis.
2. Insert the connector from intrusion switch cable into the connector on the system board.

Next steps

1. Install the [side cover](#).
2. Follow the procedure in [after working inside your computer](#).

Hard drive

Removing the 2.5-inch hard drive

Prerequisites

1. Follow the procedure in [before working inside your computer](#).
2. Remove the [side cover](#).
3. Remove the [front bezel](#).

About this task

The following images indicate the location of the 2.5-inch hard drive and provide a visual representation of the removal procedure.

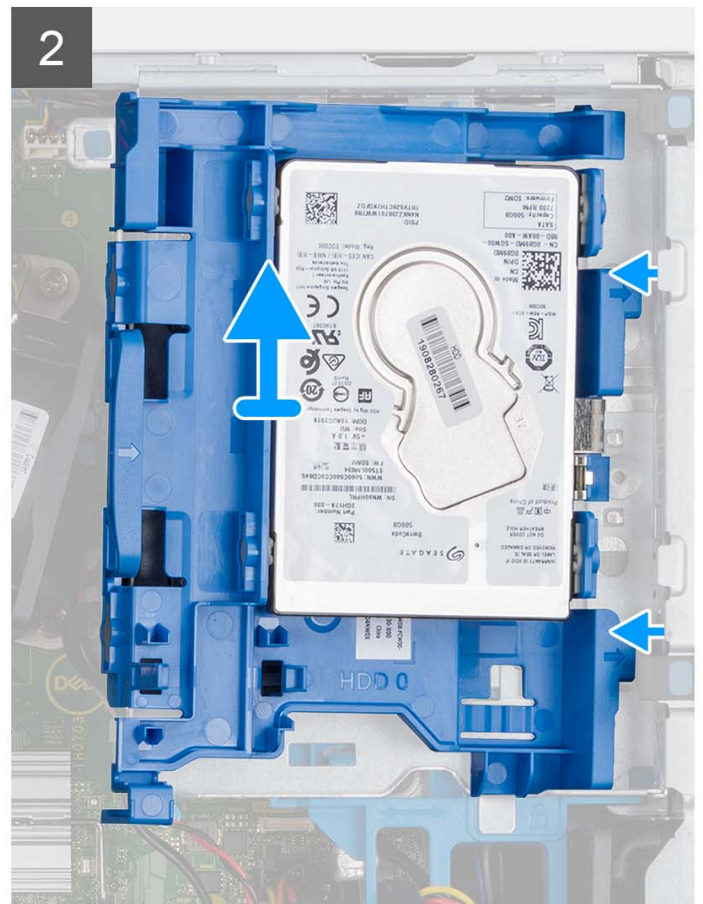
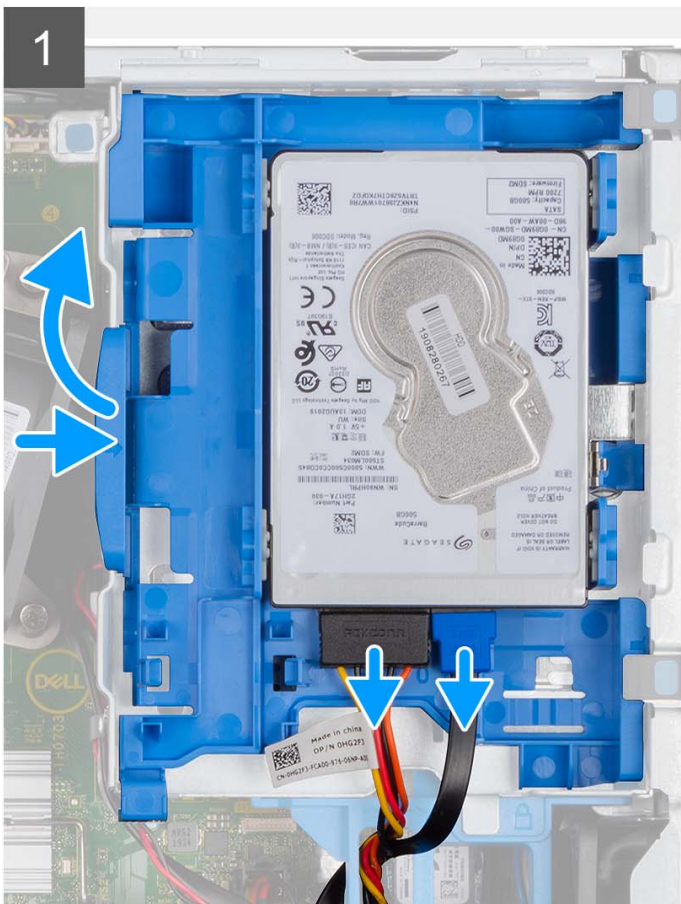
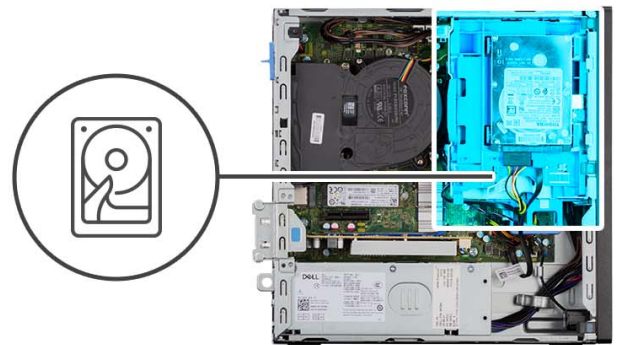

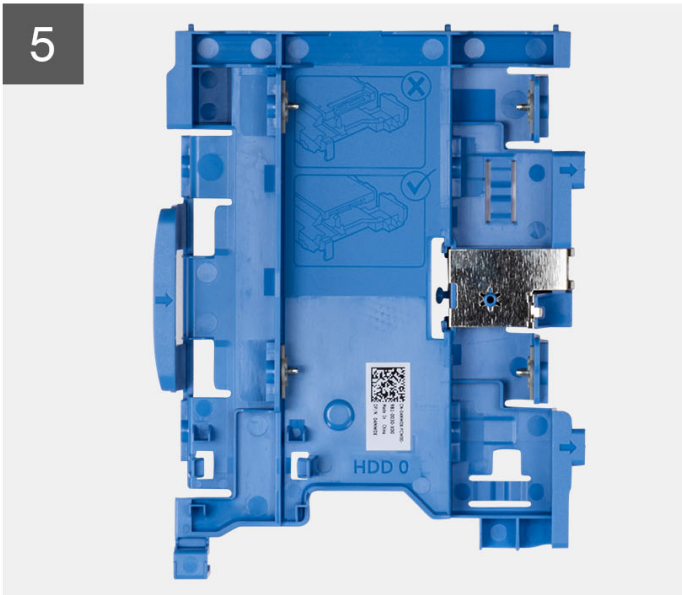
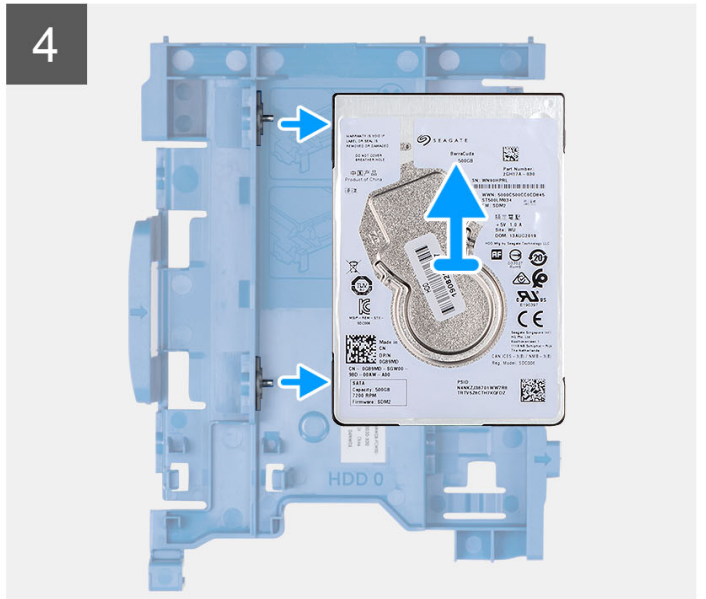
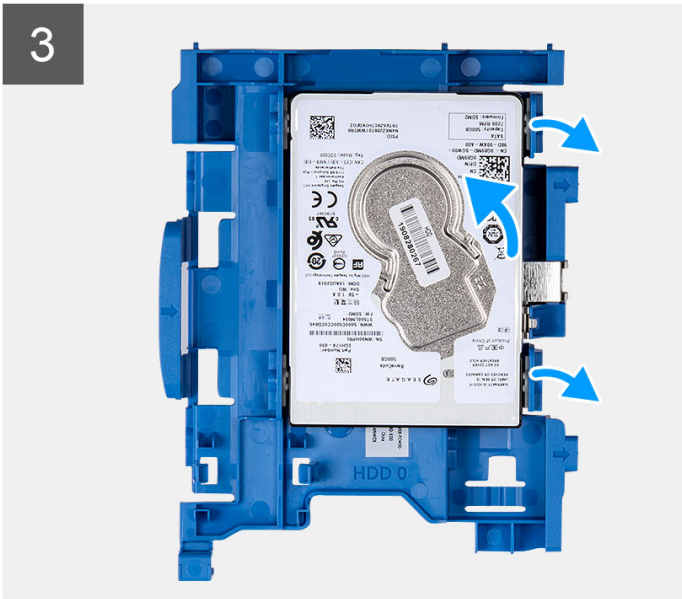



8x
M3x3

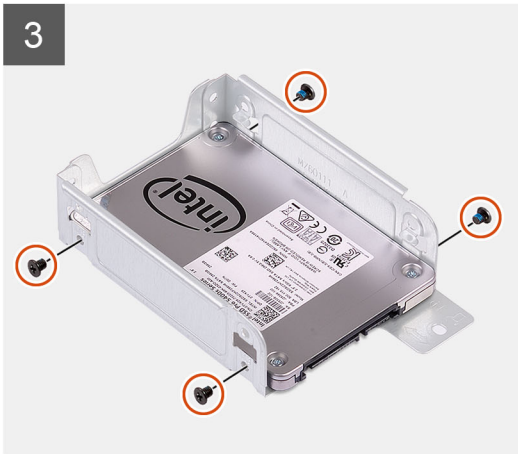
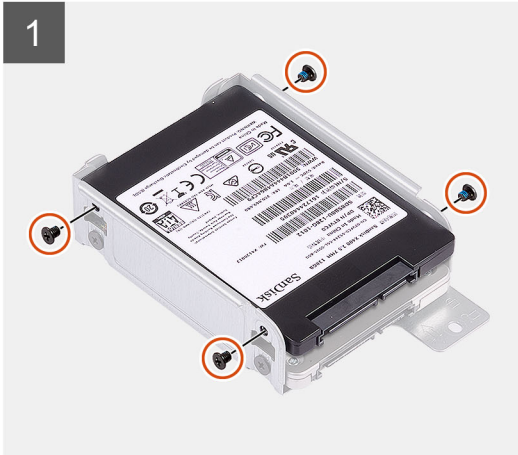

Steps

1. Disconnect the hard-drive data and power cables from the connectors on the 2.5-inch hard drive.
2. Press the tab on the hard-drive carrier and lift the hard-drive carrier to release the hard-drive carrier from the chassis.
i **NOTE:** The hard-drive's power and data cables can only be connected from the bottom side of the caddy. Make a note of the orientation of the hard drive to avoid errors during installation.
3. Slide the hard-drive carrier away from the chassis and lift the hard-drive carrier out of the hard-drive and optical-drive bracket.
4. Pry the hard-drive carrier to release the 2.5-inch hard-drive from the mounting points on the hard-drive carrier.
5. Slide and lift the 2.5-inch hard drive off the hard-drive carrier.

Installing the 2.5-inch hard drive

Prerequisites

If you are replacing a component, remove the existing component before performing the installation procedure.

About this task

The following images indicate the location of the 2.5-inch hard drive and provide a visual representation of the installation procedure.

i **NOTE:** For systems that support dual 2.5-inch hard drives, the second 2.5-inch hard drive can be mounted to the back of the hard-driver carrier. The installation steps remain the same for both hard-drives.

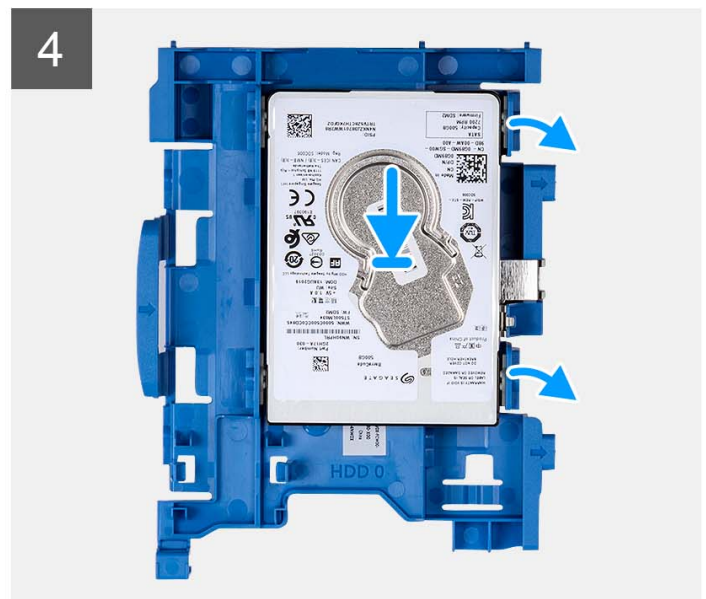
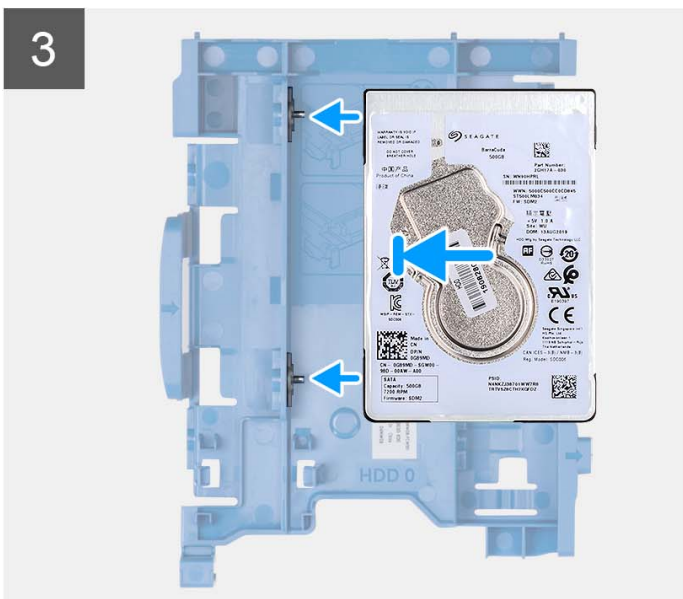
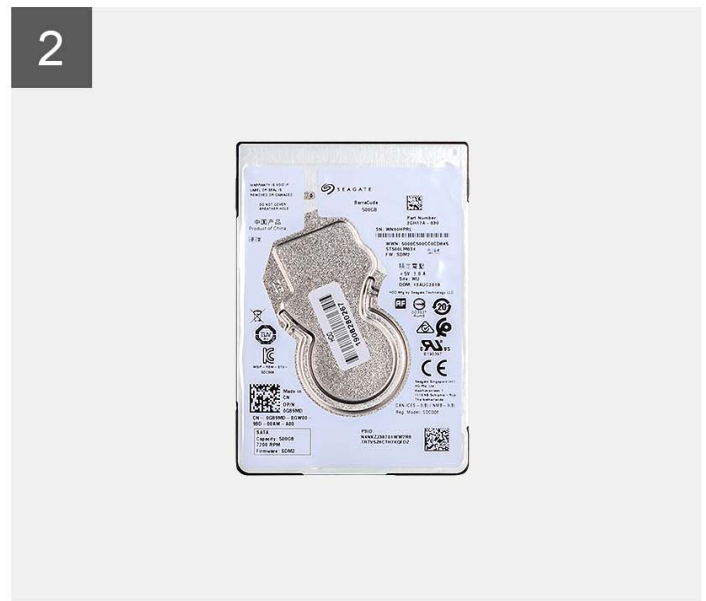
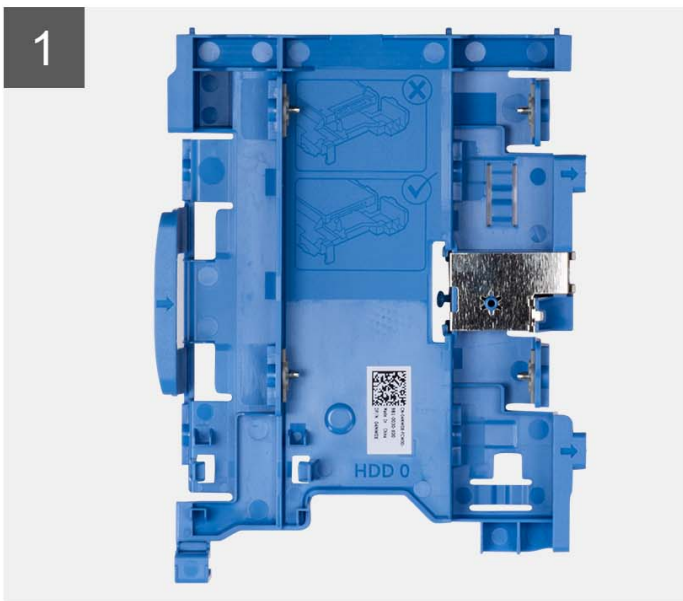
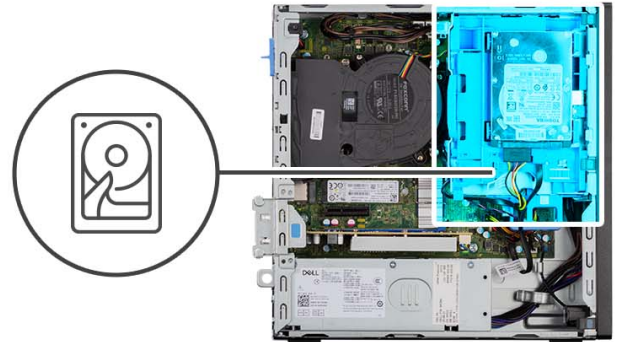

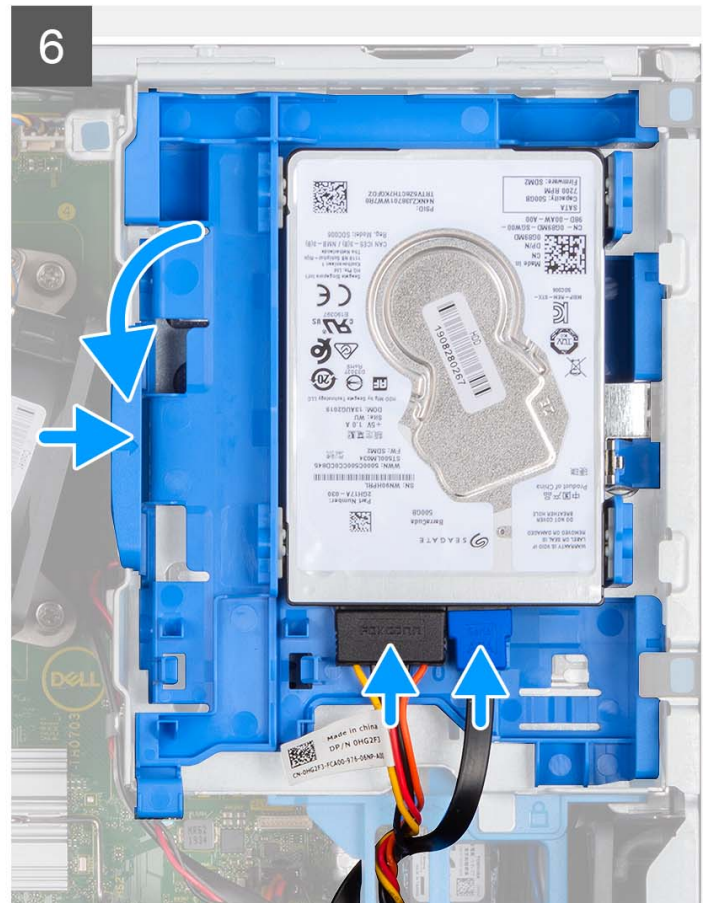
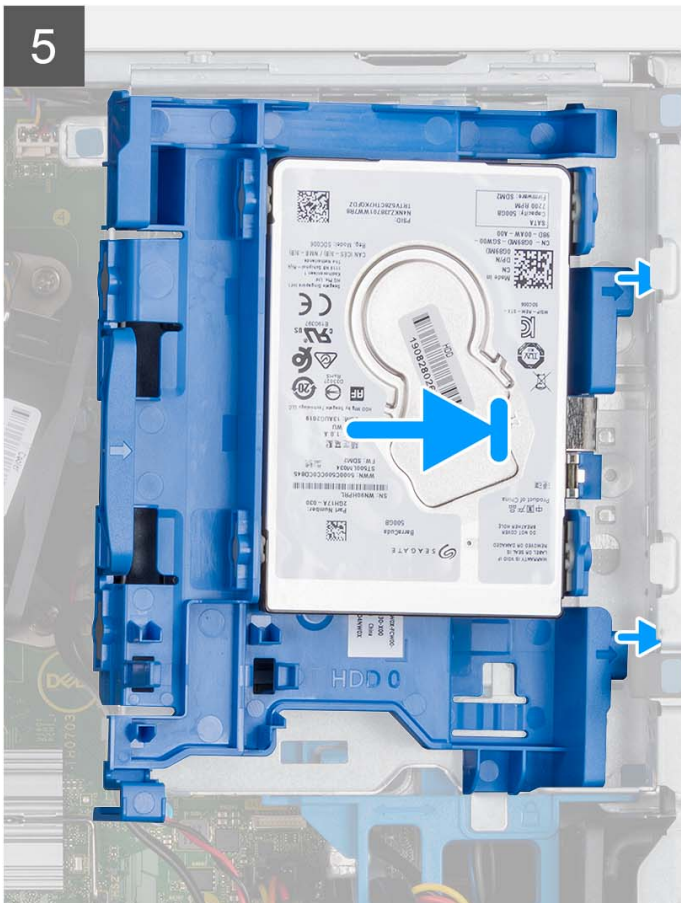

Steps

1. Align the slots on the 2.5-inch hard drive with the mounting points on the hard-drive carrier.
2. Pry the hard-drive carrier to align the mounting points on the hard-drive carrier with the slots on the 2.5-inch hard drive.
3. Snap the 2.5-inch hard drive onto the hard-drive carrier.
4. Align the tabs on the hard-drive carrier with the slots on the chassis and snap the hard-drive carrier onto the disk-drive cage.

i **NOTE:** Use the arrows seen on the caddy as guides to identify the tabs on the tray.

5. Connect the hard-drive data and power cables to the connectors on the hard drive.

Next steps

1. Install the [front bezel](#).
2. Install the [side cover](#).
3. Follow the procedure in [after working inside your computer](#).

Removing the 3.5-inch hard drive

Prerequisites

1. Follow the procedure in [before working inside your computer](#).
2. Remove the [side cover](#).
3. Remove the [front bezel](#).

About this task

The following images indicate the location of the 3.5-inch hard drive and provide a visual representation of the removal procedure.

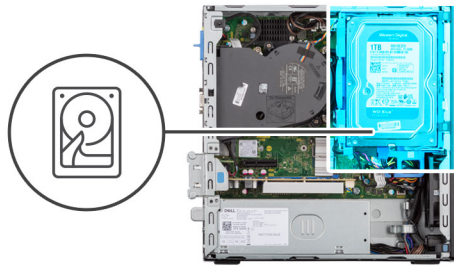

Steps

1. Disconnect the hard-drive data and power cables from the connectors on the 3.5-inch hard drive.
2. Press the tab on the hard-drive carrier and lift the hard-drive carrier.
3. Slide the hard-drive carrier away from the chassis and lift hard-drive carrier out of the disk-drive cage.
4. Pry the hard-drive carrier to release the mounting points on the carrier from the slots on the 3.5-inch hard drive.
5. Lift the 3.5-inch hard drive off the hard-drive carrier.

Installing the 3.5-inch hard drive

Prerequisites

If you are replacing a component, remove the existing component before performing the installation procedure.

About this task

The following images indicate the location of the 3.5-inch hard drive and provide a visual representation of the installation procedure.

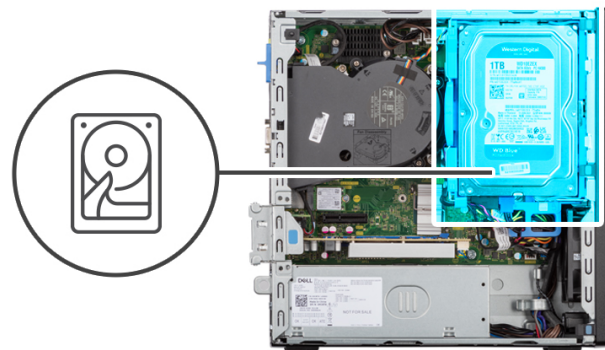

1



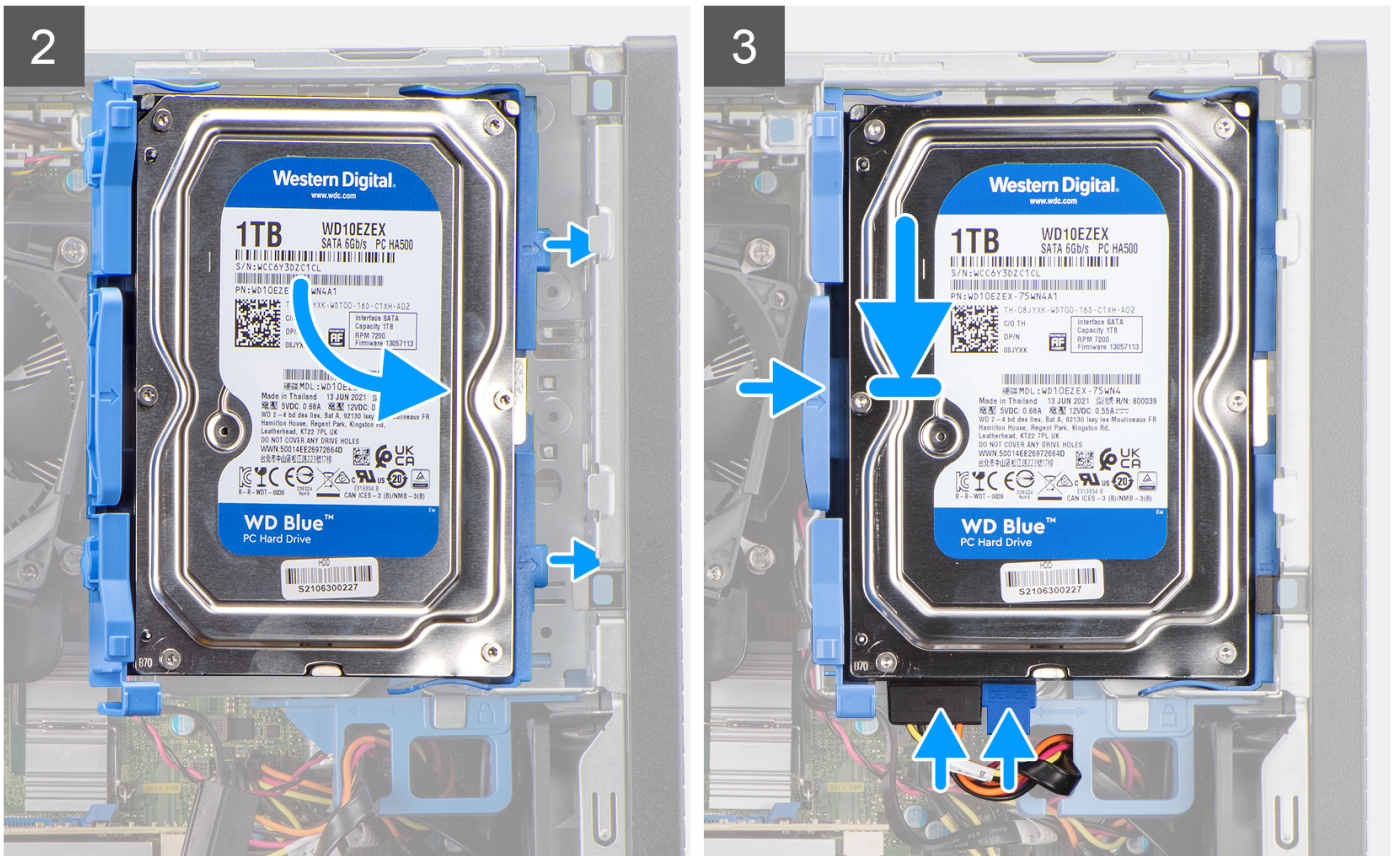

Steps

1. Align the mounting points on the carrier with the slots on the hard drive.
2. Snap the 3.5-inch hard-drive onto the hard-drive carrier.
3. Align the tabs on the hard-drive carrier with the slots on the chassis and snap the hard-drive carrier onto the disk-drive cage.

NOTE: Use the arrows seen on the caddy as guides to identify the tabs on the tray.

4. Connect the hard-drive data and power cables to the connectors on the hard drive.

Next steps

1. Install the [front bezel](#).
2. Install the [side cover](#).
3. Follow the procedure in [after working inside your computer](#).

Hard-drive and optical-drive bracket

Removing the hard-drive and optical-drive bracket

Prerequisites

1. Follow the procedure in [before working inside your computer](#).
2. Remove the [side cover](#).
3. Remove the [front bezel](#).
4. Remove the [2.5-inch hard-drive](#).
5. Remove the [3.5-inch hard-drive](#).

About this task

The following images indicate the location of the hard-drive and optical-drive bracket and provide a visual representation of the removal procedure.

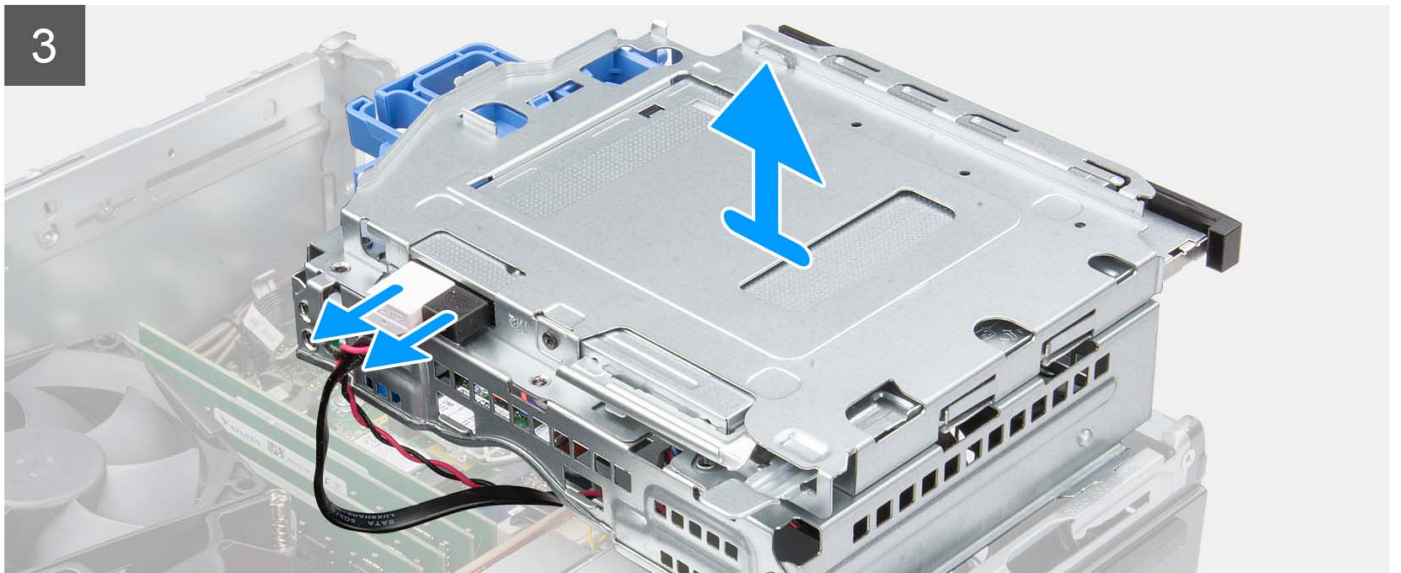
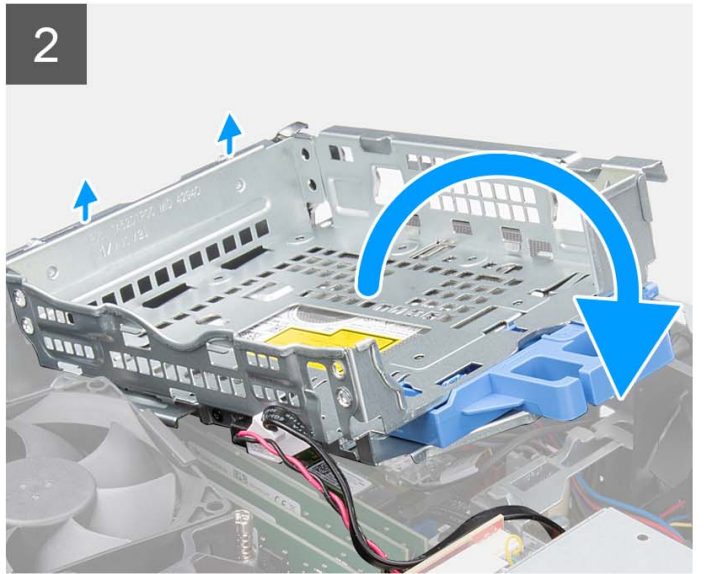
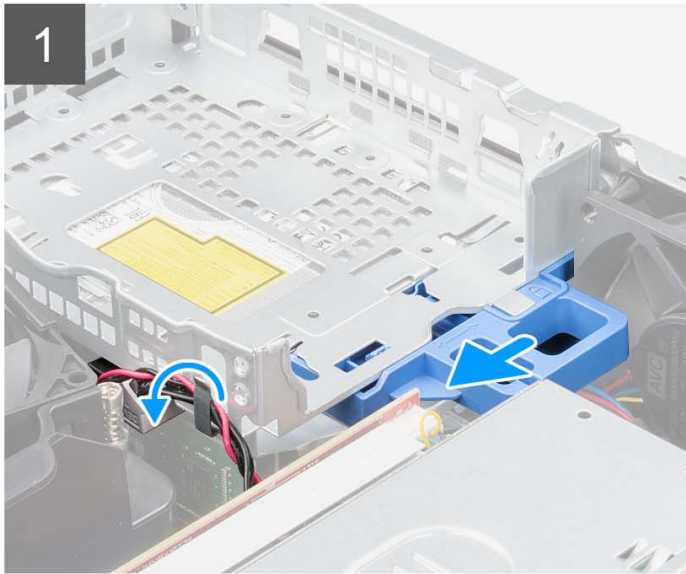

Steps

1. Remove the hard-drive power and data cables that are routed via the locking mechanism.
2. Remove the cables from the routing points on the bracket.
3. Move the lock handle from the locking mechanism towards the left to unlock the bracket and detach it from the chassis.

4. Hold the lock handle to lift the bracket.
5. Lift the bracket upwards and detach it from the mounting points on the top portion of the chassis.
6. Disconnect the power and SATA cables from the optical drive and lift the bracket away from the computer.

Installing the hard-drive and optical-drive bracket

Prerequisites

If you are replacing a component, remove the existing component before performing the installation procedure.

About this task

The following image indicates the location of the hard-drive and optical-drive bracket and provides a visual representation of the installation procedure.

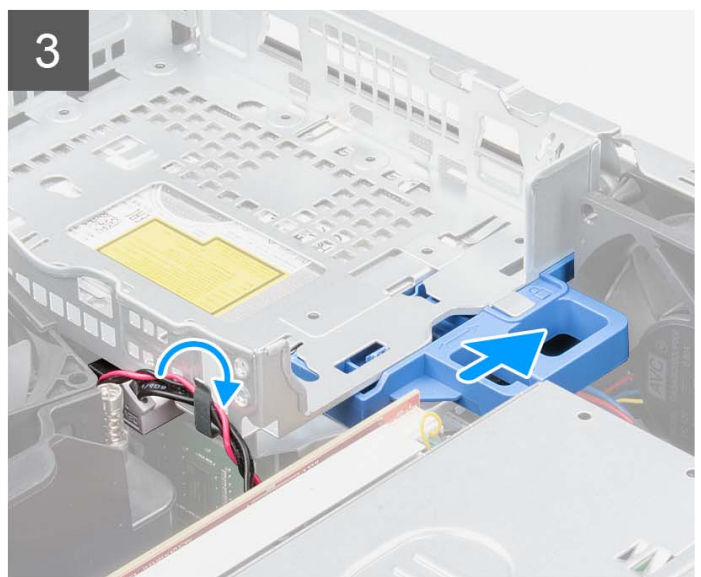
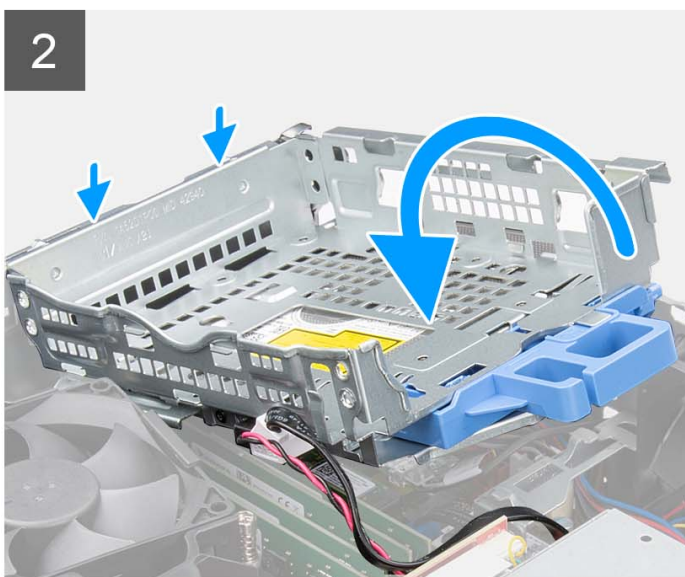
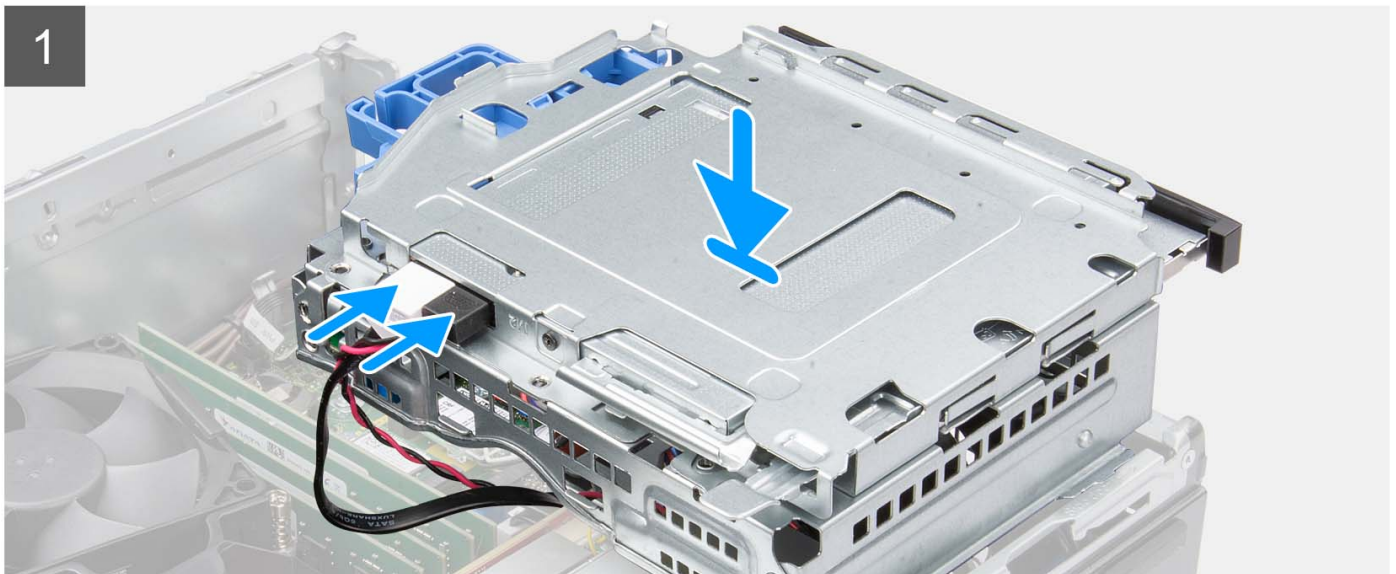

Steps

1. Connect the power and SATA cables to the optical drive while holding the bracket upside down.
2. Hold the bracket upright and align the mounting points with the ones on the chassis.
3. Push the bracket until the assembly is secured onto the chassis.
4. Move the lock handle from the locking mechanism towards the right to lock the bracket in place.
5. Route the optical drive's power and data cables through the routing guide on the bracket.
6. Route the hard-drive power and SATA cables through the routing guide on the lock.

Next steps

1. Install the [3.5-inch hard-drive](#).
2. Install the [2.5-inch hard-drive](#).
3. Install the [front bezel](#).
4. Install the [side cover](#).
5. Follow the procedure in [after working inside your computer](#).

Optical drive

Removing the optical drive

Prerequisites

1. Follow the procedure in [before working inside your computer](#).
2. Remove the [side cover](#).
3. Remove the [front bezel](#).
4. Remove the [2.5-inch hard-drive](#).
5. Remove the [3.5-inch hard-drive](#).
6. Remove the [hard-drive and optical-drive bracket](#).

About this task

The following images show the slim optical-drive and provide a visual representation of the removal procedure.

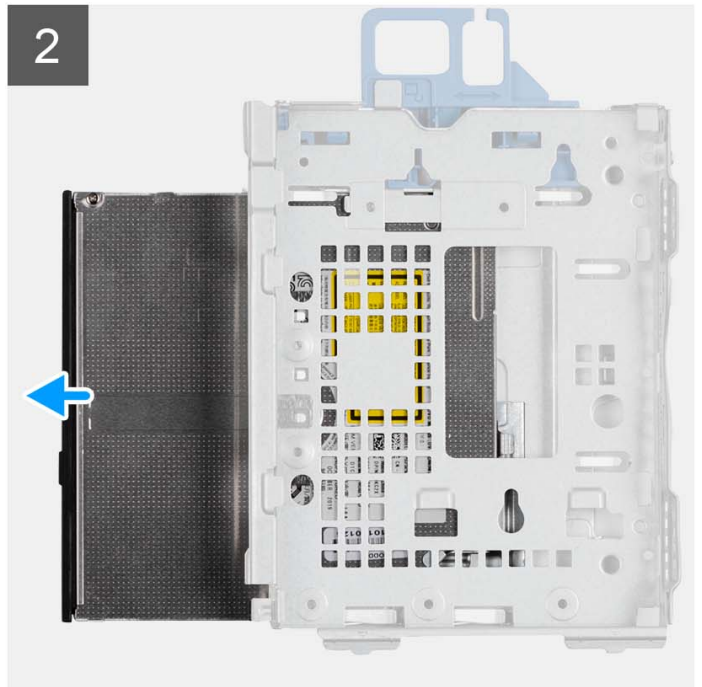
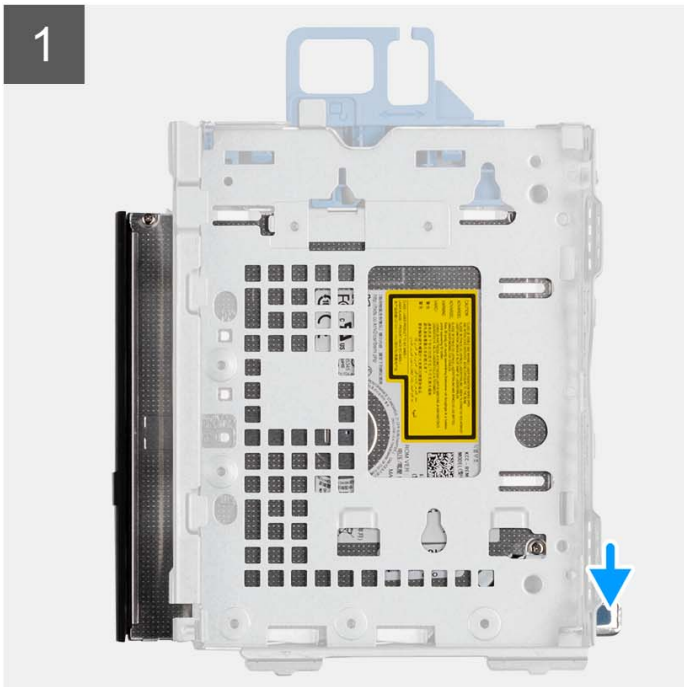
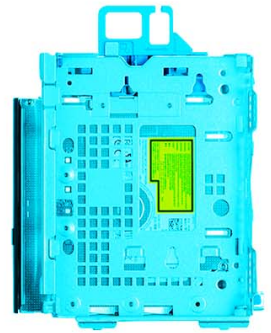

Steps

1. Press the tab on the optical drive to release the optical drive from the hard-drive and optical drive bracket.

2. Slide the optical drive out of the hard-drive and optical drive bracket.

Installing the optical-drive

Prerequisites

If you are replacing a component, remove the existing component before performing the installation procedure.

About this task

The following images show the optical-drive and provide a visual representation of the installation procedure.

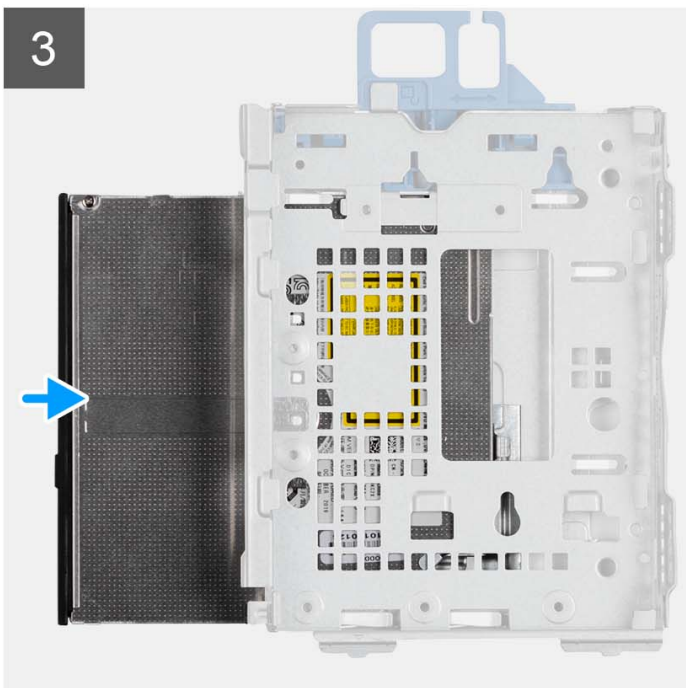
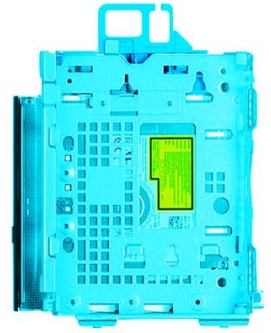

Steps

Slide the optical drive into the hard-drive and optical-drive bracket until it snaps into place.

Next steps

1. Install the [hard-drive and optical-drive bracket](#).
2. Install the [3.5-inch hard-drive](#).
3. Install the [2.5-inch hard-drive](#).
4. Install the [front bezel](#).
5. Install the [side cover](#).
6. Follow the procedure in [after working inside your computer](#).

Solid-state drive

Removing the M.2 2230 solid-state drive

Prerequisites

1. Follow the procedure in [before working inside your computer](#).
2. Remove the [side cover](#).
3. Remove the [front bezel](#).
4. Remove the [2.5-inch hard-drive](#).
5. Remove the [3.5-inch hard-drive](#).
6. Remove the [hard-drive and optical-drive cage](#).

About this task

The following images indicate the location of the M.2 2230 solid-state drive and provide a visual representation of the removal procedure.



1x
M2x3



Steps

1. Remove the single (M2x3) screw that secures the solid-state drive to the system board.
2. Slide and lift the 2230 solid-state drive from the M.2 card slot on the system board.

Installing the M.2 2230 solid-state drive

Prerequisites

If you are replacing a component, remove the existing component before performing the installation procedure.

About this task

The following images indicate the location of the M.2 2230 solid-state drive and provide a visual representation of the installation procedure.



1x
M2x3

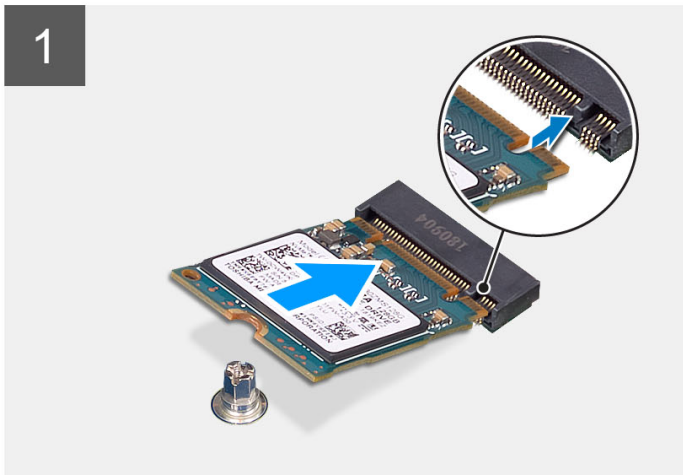

Steps

1. Align the notch on the 2230 solid-state drive with the tab on the M.2 card slot on the system board.
2. Slide the 2230 solid-state drive into the M.2 card slot on the system board. Replace the screw (M2x3) that secures the 2230 solid-state drive to the system board.

Next steps

1. Install the [hard-drive and optical-drive bracket](#).
2. Install the [3.5-inch hard-drive](#).
3. Install the [2.5-inch hard-drive](#).
4. Install the [front bezel](#).
5. Install the [side cover](#).
6. Follow the procedure in [after working inside your computer](#).

Removing the M.2 2280 solid-state drive

Prerequisites

1. Follow the procedure in [before working inside your computer](#).
2. Remove the [side cover](#).

3. Remove the [front bezel](#).
4. Remove the [2.5-inch hard-drive](#).
5. Remove the [3.5-inch hard-drive](#).
6. Remove the [hard-drive and optical-drive bracket](#).

About this task

The following images indicate the location of the M.2 2280 solid-state drive and provide a visual representation of the removal procedure.



1x
M2x3

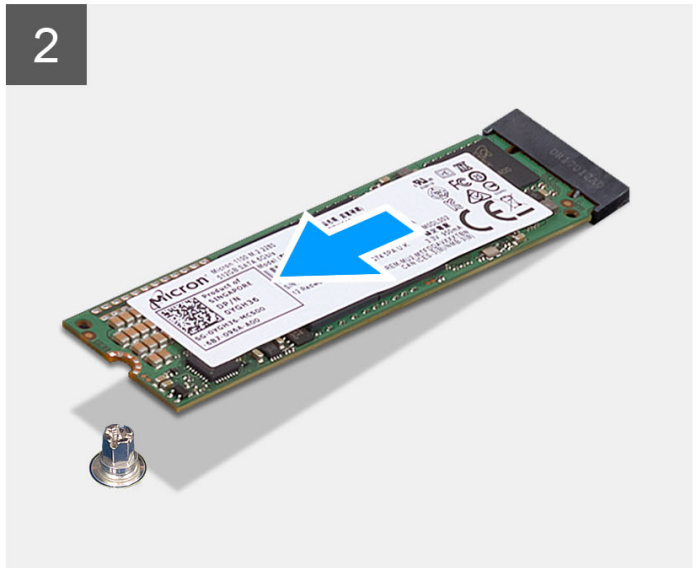

Steps

1. Remove the (M2x3) screw that secures the 2280 solid-state drive to the system board.
2. Slide and lift the 2280 solid-state drive from the M.2 card slot on the system board.

Installing the M.2 2280 solid-state drive

Prerequisites

If you are replacing a component, remove the existing component before performing the installation procedure.

About this task

The following images indicates the location of the M.2 2280 solid-state drive and provide a visual representation of the installation procedure.



1x
M2x3

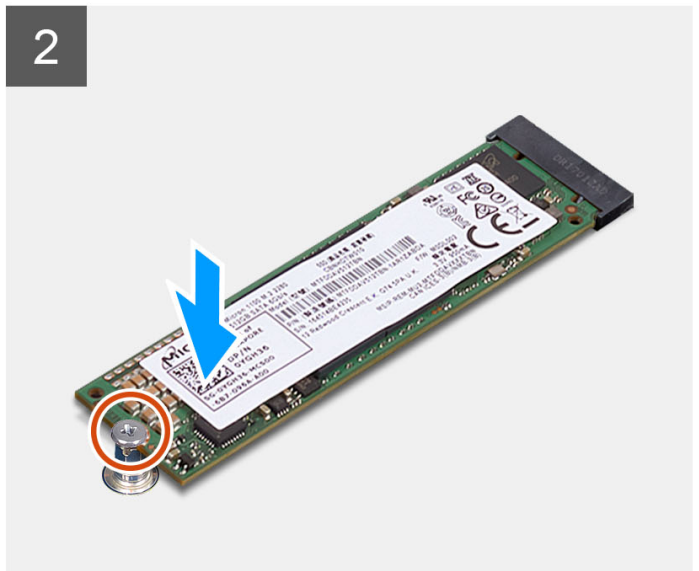
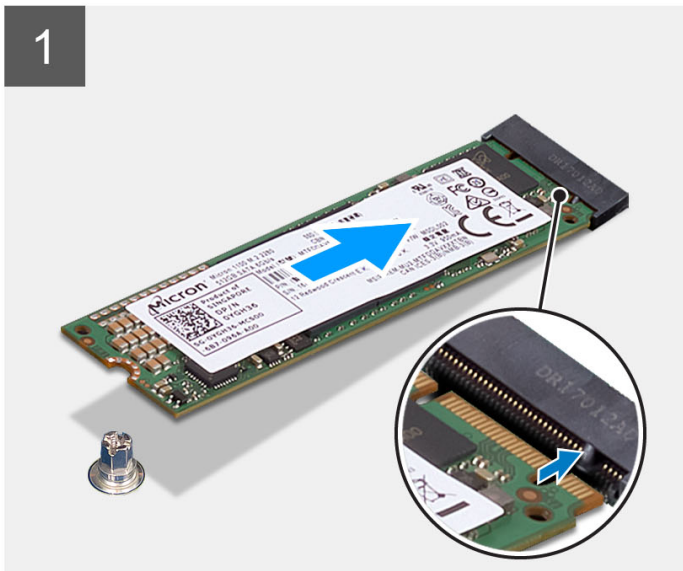

Steps

1. Align the notch on the 2290 solid-state drive with the tab on the M.2 card slot on the system board.
2. Slide the 2280 solid-state drive into the M.2 card slot on the system board.
3. Replace the screw (M2x3) that secures the 2280 solid-state drive to the system board.

Next steps

1. Install the [hard-drive and optical-drive bracket](#).
2. Install the [3.5-inch hard-drive](#).
3. Install the [2.5-inch hard-drive](#).
4. Install the [front bezel](#).
5. Install the [side cover](#).
6. Follow the procedure in [after working inside your computer](#).

Removing and installing the M.2 screw mount

About this task

The following image provides a visual representation of the procedure to remove and install the M.2 screw mount on the system board.

 **NOTE:** Moving the M.2 screw mount would accommodate the installation of an M.2 2230 or 2280 solid-state drive in the same slot.

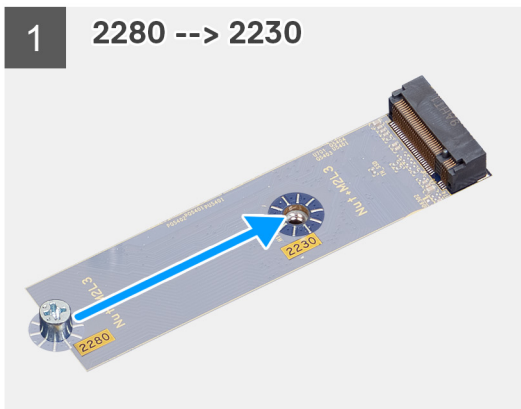
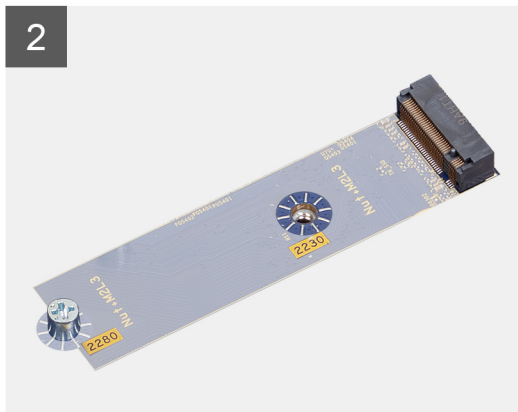
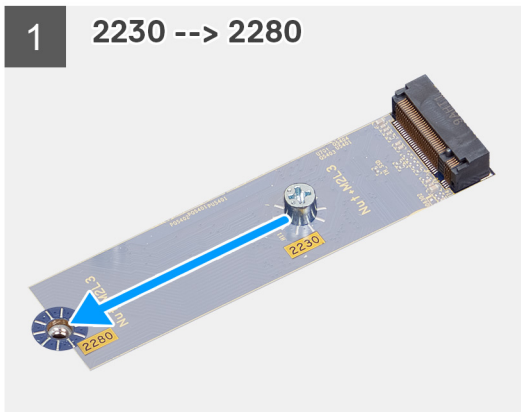

Hard-drive and optical-drive supporting bracket

Removing the hard-drive and optical-drive supporting bracket

Prerequisites

1. Follow the procedure in [before working inside your computer](#).
2. Remove the [side cover](#).
3. Remove the [front bezel](#).
4. Remove the [2.5-inch hard-drive](#).
5. Remove the [3.5-inch hard-drive](#).
6. Remove the [hard-drive and optical-drive bracket](#).

About this task

The following images indicate the location of the hard-drive and optical-drive supporting bracket and provide a visual representation of the removal procedure.



2x
#6-32

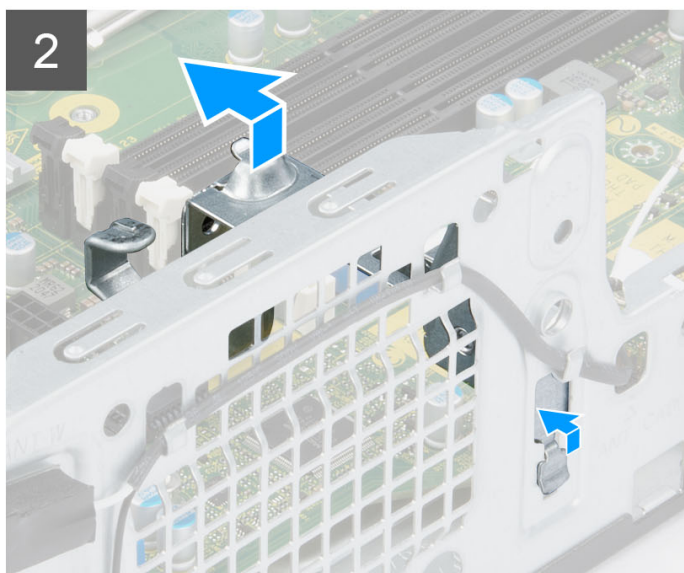
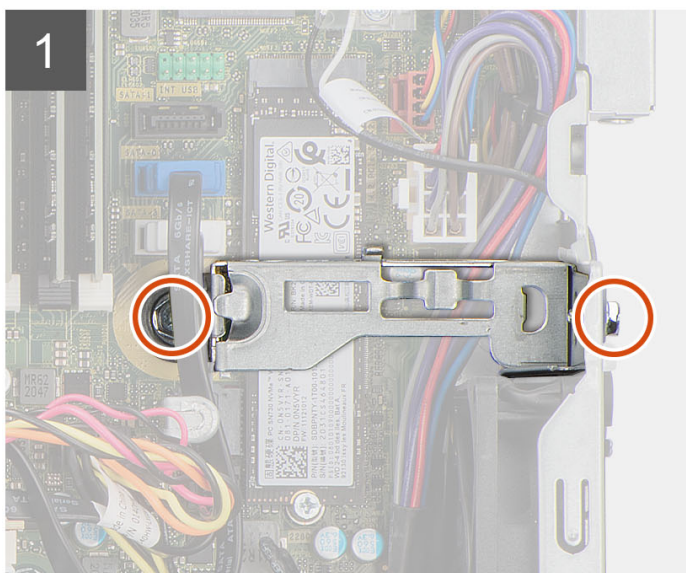

Steps

1. Remove the two (#6-32) screws that secures the bracket to the chassis.
2. Push the bracket to free it from the front side of the chassis.
3. Lift and remove the bracket from the system.

Installing the hard-drive and optical-drive supporting bracket

Prerequisites

If you are replacing a component, remove the existing component before performing the installation procedure.

About this task

The following images indicate the location of the hard-drive and optical-drive supporting bracket and provides a visual representation of the installation procedure.



2x
#6-32

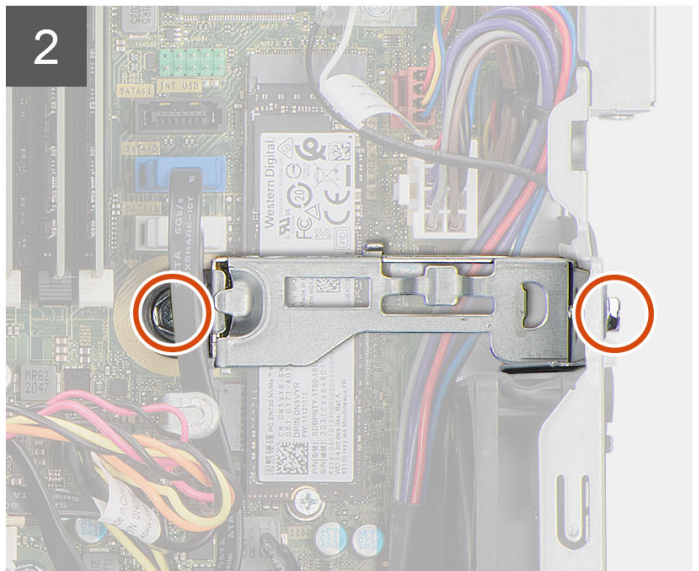
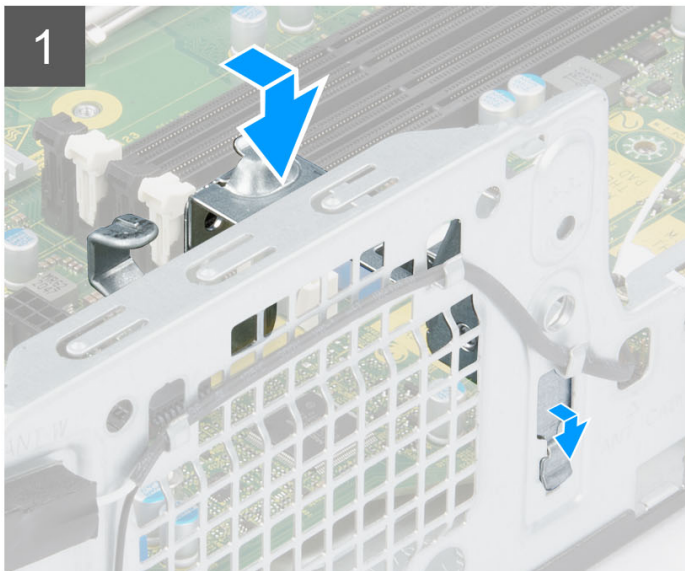

Steps

1. Align and place the bracket on the slot on the chassis.
2. Replace the two (#6-32) screws that secures the bracket to the chassis.

Next steps

1. Install the [hard-drive and optical-drive bracket](#).
2. Install the [3.5-inch hard-drive](#).
3. Install the [2.5-inch hard-drive](#).
4. Install the [front bezel](#).
5. Install the [side cover](#).
6. Follow the procedure in [after working inside your computer](#).

SD-card reader

Removing the SD-card reader

Prerequisites

1. Follow the procedure in [before working inside your computer](#).
2. Remove the [side cover](#).
3. Remove the [front bezel](#).
4. Remove the [2.5-inch hard-drive](#).
5. Remove the [3.5-inch hard-drive](#).
6. Remove the [hard-drive and optical-drive cage](#).

About this task

The following images indicate the location of the SD-card reader and provide a visual representation of the removal procedure.



2x
M3x5

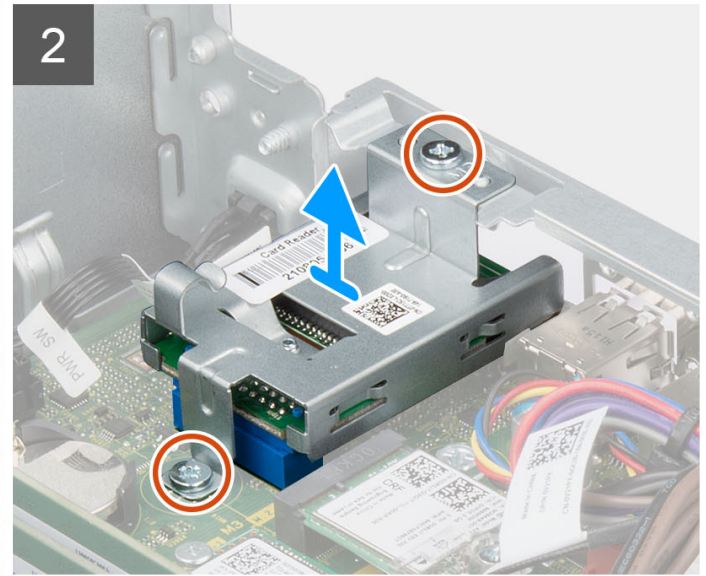
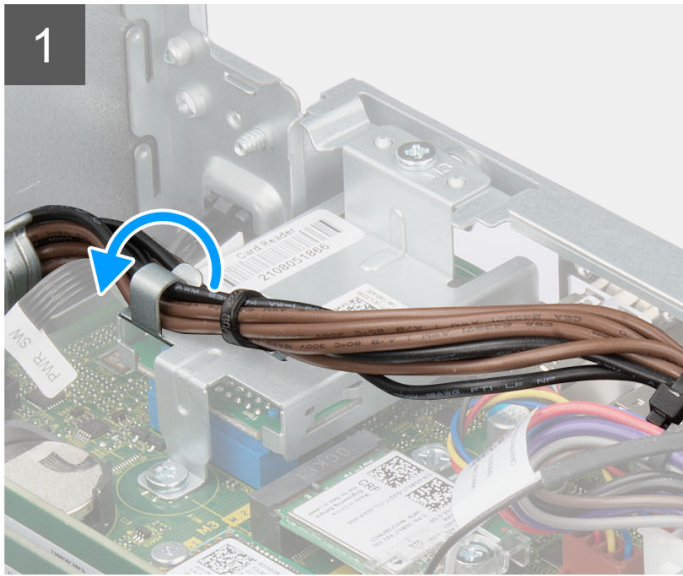

Steps

1. Remove the power-supply cables from the routing guides on the SD-card reader bracket.
2. Remove the two screws (M3x5) that secure the SD-card bracket to the system board and the chassis.
3. Disconnect the SD-card reader from the connector on the system board.
4. Lift and remove the SD-card reader from the system.

Installing the SD-card reader

Prerequisites

If you are replacing a component, remove the existing component before performing the installation procedure.

About this task

The following images indicate the location of the SD-card reader and provide a visual representation of the installation procedure.



2x
M3x5

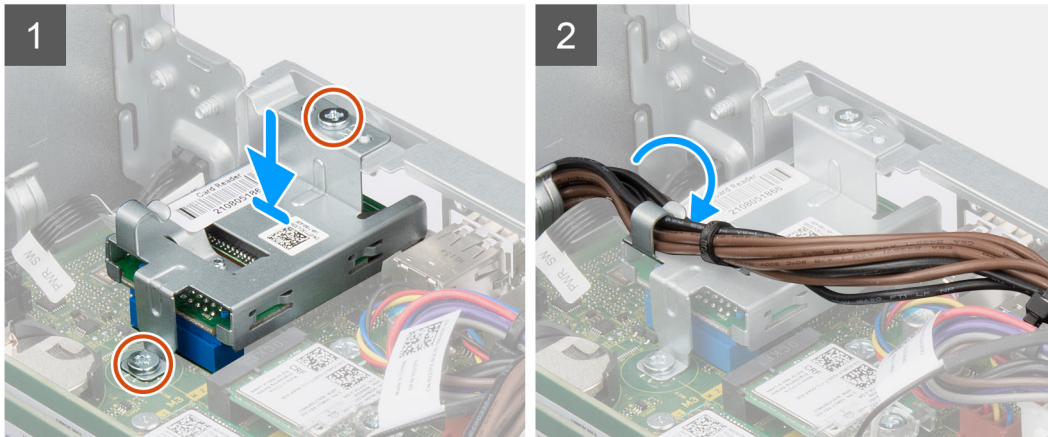

Steps

1. Place and align the screw holes on the SD-card reader to the screw holes on the chassis.
2. Connect the SD-card reader to the connector on the system board.
3. Replace the two screws (M3x5) that secure the SD-card bracket to the system board and the chassis.
4. Route the power-supply cables through the routing guides on the SD-card reader bracket.

Next steps

1. Install the [hard-drive and optical-drive cage](#).
2. Install the [3.5-inch hard-drive](#).
3. Install the [2.5-inch hard-drive](#).
4. Install the [front bezel](#).
5. Install the [side cover](#).
6. Follow the procedure in [after working inside your computer](#).

Coin-cell battery

Removing the coin-cell battery

Prerequisites

1. Follow the procedure in [before working inside your computer](#).
2. Remove the [side cover](#).
3. Remove the [2.5-inch hard-drive](#).
4. Remove the [3.5-inch hard-drive](#).
5. Remove the [hard-drive and optical-drive bracket](#).

NOTE: Removing the coin-cell battery resets the BIOS setup program settings to default. It is recommended that you note the BIOS setup program settings before removing the coin-cell battery.

About this task

The following images indicate the location of the coin-cell battery and provide a visual representation of the removal procedure.

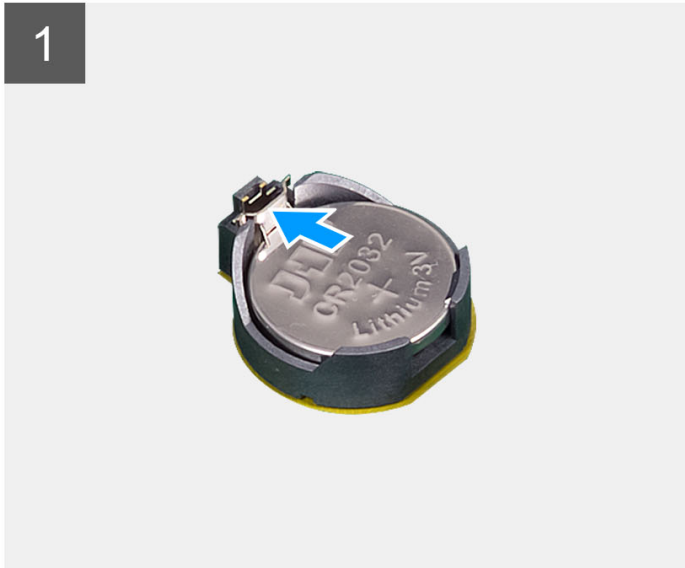
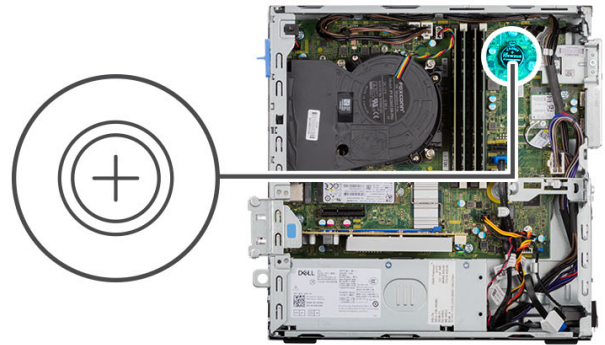

Steps

1. Push the coin-cell battery-release lever on the coin-cell battery socket to release the coin-cell battery out of the socket.
2. Remove the coin-cell battery.

Installing the coin-cell battery

Prerequisites

If you are replacing a component, remove the existing component before performing the installation procedure.

About this task

The following image indicates the location of the coin-cell battery and provides a visual representation of the installation procedure.

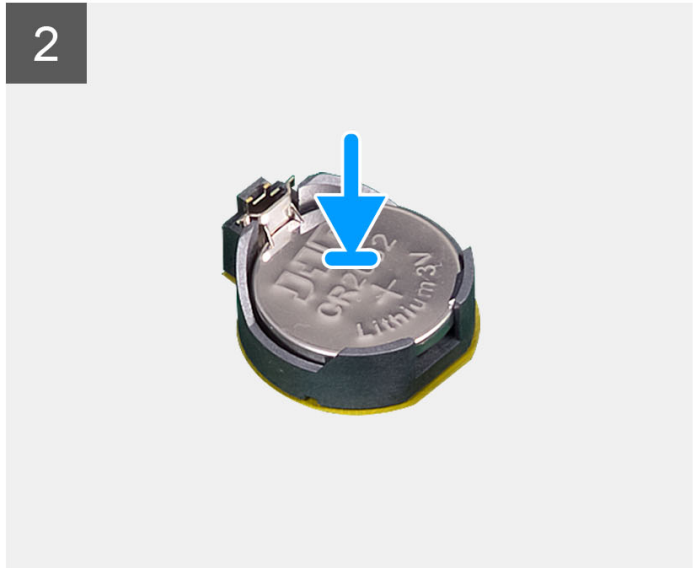
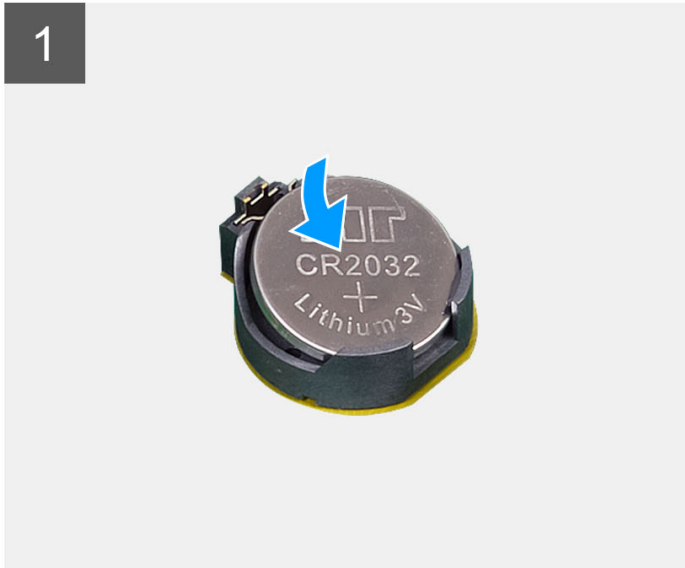
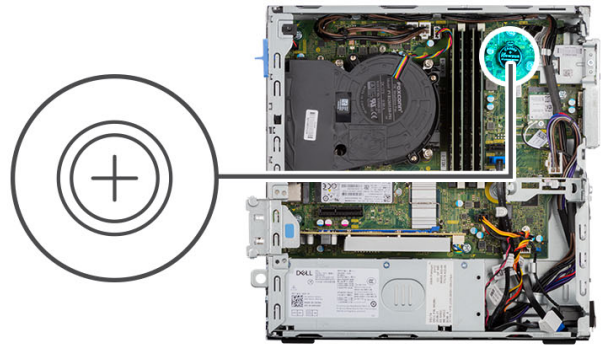

Steps

Insert the coin-cell battery into the socket with the positive side (+) label facing up and snap the battery in the socket.

Next steps

1. Install the [hard-drive and optical-drive bracket](#).
2. Install the [3.5-inch hard-drive](#).
3. Install the [2.5-inch hard-drive](#).
4. Install the [side cover](#).
5. Follow the procedure in [after working inside your computer](#).

Power button

Removing the power button

Prerequisites

1. Follow the procedure in [before working inside your computer](#).
2. Remove the [side cover](#).
3. Remove the [front bezel](#).
4. Remove the [2.5-inch hard-drive](#).
5. Remove the [3.5-inch hard-drive](#).
6. Remove the [hard-drive and optical-drive cage](#).

About this task

The following images indicate the location of the power button and provide a visual representation of the removal procedure.

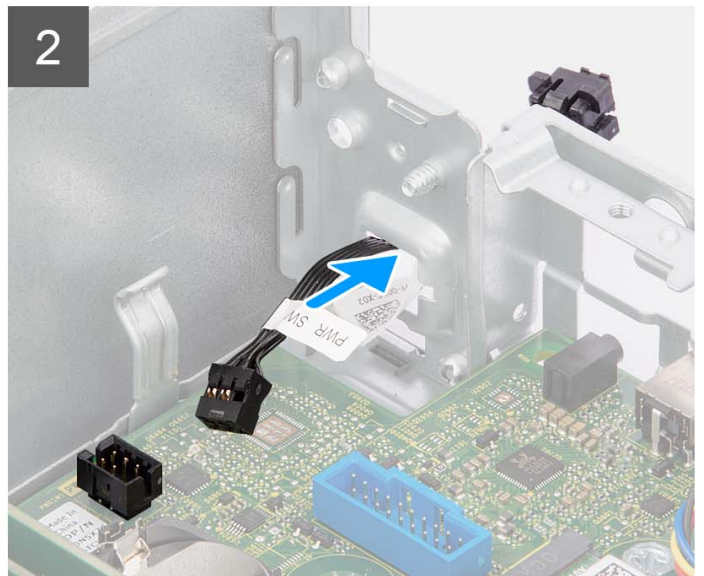
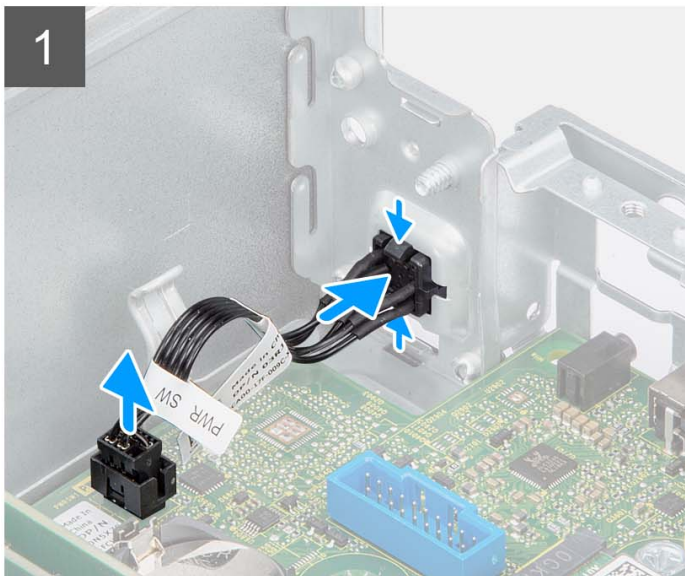
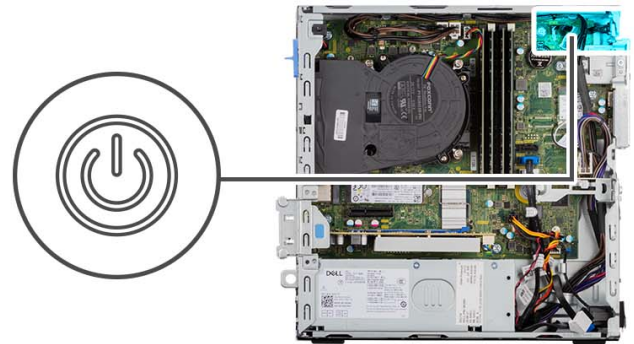

Steps

1. Disconnect the power-button cable from the connector on the system board.
2. Press the release tabs on the power-button head and push the power button through the slot on the chassis.
3. Remove the power button and its cable from the from the slot on the chassis.

Installing the power button

Prerequisites

If you are replacing a component, remove the existing component before performing the installation procedure.

About this task

The following images indicate the location of the power button and provide a visual representation of the installation procedure.

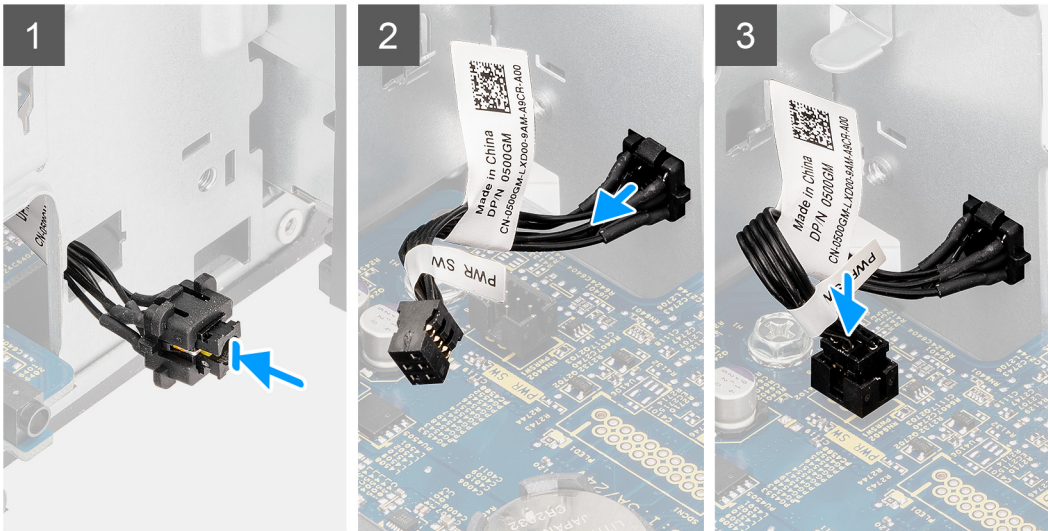
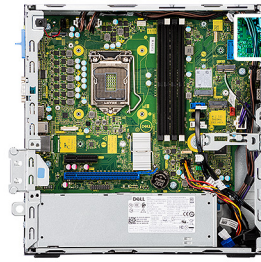

Steps

1. Insert the power button and its cable into the slot on the chassis.
2. Press the power button until it is seated on the slot on the chassis.
3. Connect the power-button cable to the connector on the system board.

Next steps

1. Install the [hard-drive and optical-drive cage](#).
2. Install the [3.5-inch hard-drive](#).
3. Install the [2.5-inch hard-drive](#).
4. Install the [front bezel](#).
5. Install the [side cover](#).
6. Follow the procedure in [after working inside your computer](#).

WLAN card

Removing the WLAN card

Prerequisites

1. Follow the procedure in [before working inside your computer](#).
2. Remove the [side cover](#).
3. Remove the [front bezel](#).
4. Remove the [2.5-inch hard-drive](#).
5. Remove the [3.5-inch hard-drive](#).
6. Remove the [hard-drive and optical-drive cage](#).

About this task

The following images indicate the location of the wireless card and provide a visual representation of the removal procedure.



1x
M2x3



Steps

1. Remove the screw (M2x3) that secures the wireless card to the system board.
2. Slide and lift the wireless-card bracket off the wireless card.
3. Disconnect the antenna cables from the wireless card.
4. Slide and remove the wireless card at an angle from the wireless-card slot.

Installing the WLAN card

Prerequisites

If you are replacing a component, remove the existing component before performing the installation procedure.

About this task

The following image indicates the location of the wireless card and provides a visual representation of the installation procedure.



1x
M2x3

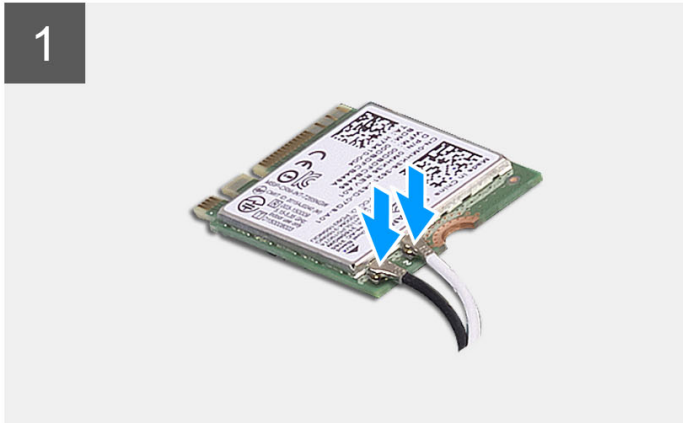

Steps

1. Connect the antenna cables to the WLAN card.
The following table provides the antenna-cable color scheme for the WLAN card of your computer.

Table 3. Antenna-cable color scheme

Connectors on the wireless card	Antenna-cable color
Main (white triangle)	White
Auxiliary (black triangle)	Black

2. Slide and place the wireless-card bracket on the wireless card.
3. Align the notch on the wireless card with the tab on the wireless-card slot.
4. Slide the wireless card at an angle into the wireless-card slot.
5. Replace the screw (M2x3) that secures the wireless card to the system board.

Next steps

1. Install the [hard-drive and optical-drive cage](#).
2. Install the [3.5-inch hard-drive](#).
3. Install the [2.5-inch hard-drive](#).
4. Install the [front bezel](#).
5. Install the [side cover](#).
6. Follow the procedure in [after working inside your computer](#).

WLAN antenna

Removing the internal WLAN antenna

Prerequisites

1. Follow the procedure in [before working inside your computer](#).
2. Remove the [side cover](#).
3. Remove the [front bezel](#).
4. Remove the [2.5-inch hard-drive](#).
5. Remove the [3.5-inch hard-drive](#).
6. Remove the [hard-drive and optical-drive cage](#).
7. Remove the [WLAN card](#).

About this task

The following images indicate the location of the internal WLAN antenna and provide a visual representation of the removal procedure.



2x
M3x5

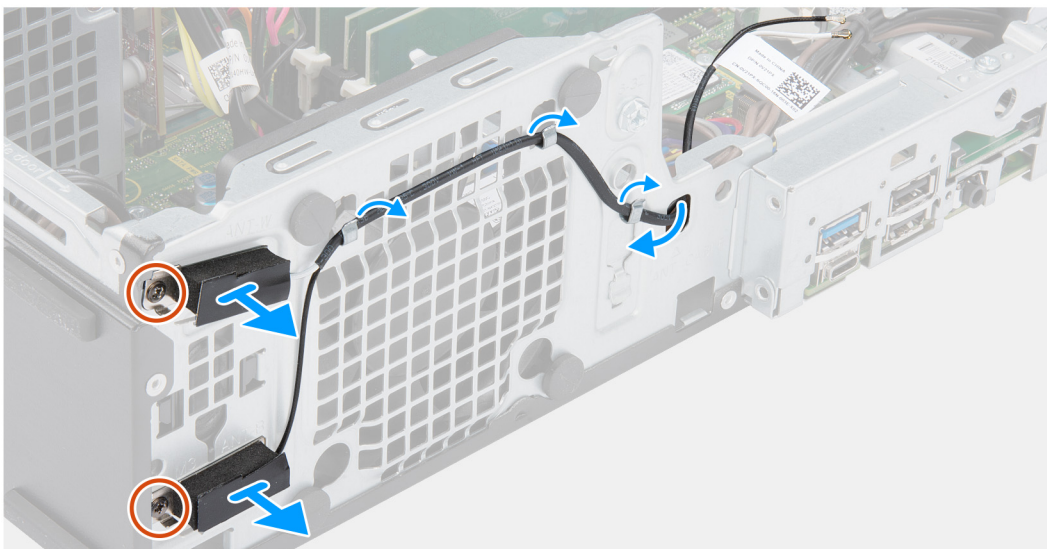

Steps

1. Remove the antenna cables from the routing guides on the chassis.

2. Remove the two (M2x3) screws that secures the WLAN antenna to the chassis.
3. Lift and remove the WLAN antenna from the chassis.

Installing the WLAN antenna

Prerequisites

If you are replacing a component, remove the existing component before performing the installation procedure.

About this task

The following image indicates the location of the WLAN antenna and provides a visual representation of the installation procedure.



2x
M3x5

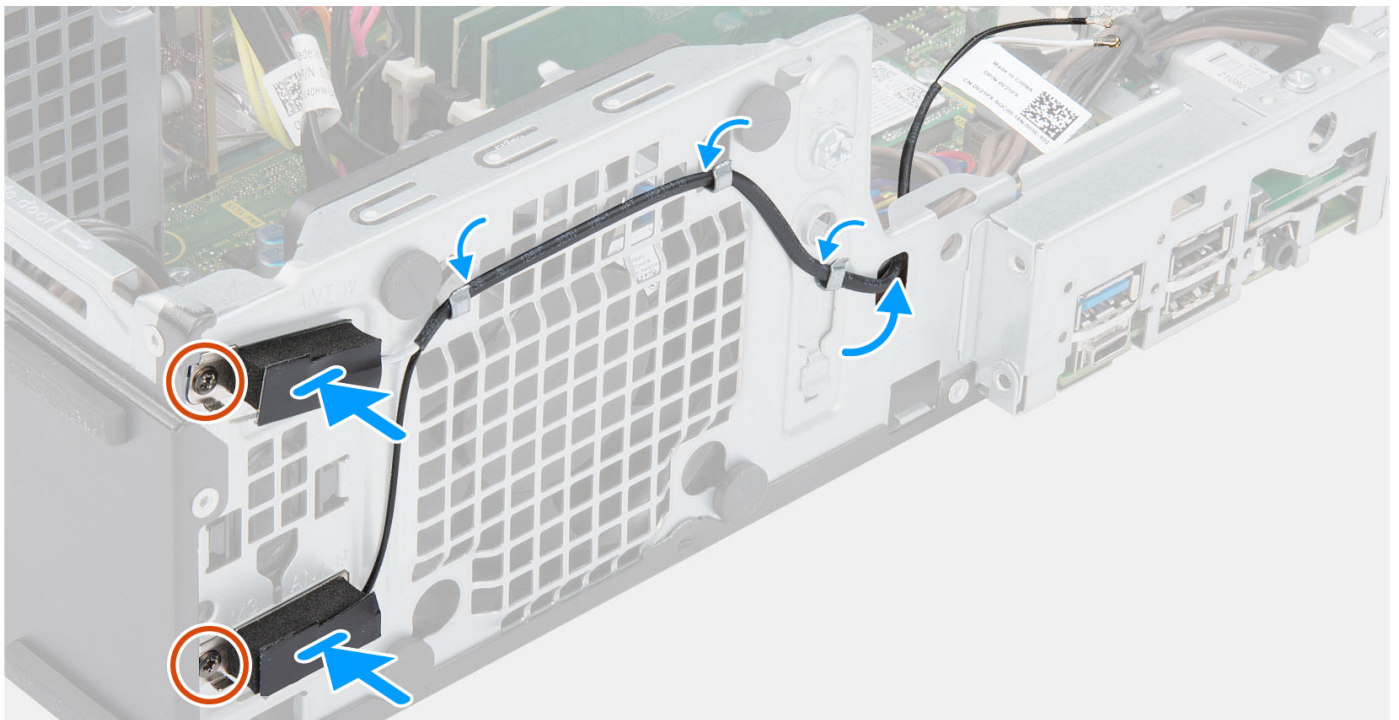

Steps

1. Route the WLAN antenna cables through the routing guides on the chassis.
2. Place and align the screw holes on the WLAN antenna with the screw holes on the chassis
3. Replace the two (M2x3) screws to secure the WLAN antenna to the chassis.

Next steps

1. Install the [hard-drive and optical-drive cage](#).
2. Install the [WLAN card](#).

3. Install the [3.5-inch hard-drive](#).
4. Install the [2.5-inch hard-drive](#).
5. Install the [front bezel](#).
6. Install the [side cover](#).
7. Follow the procedure in [after working inside your computer](#).

WLAN antennas (External)

Removing the external WLAN antenna

Prerequisites

1. Follow the procedure in [before working inside your computer](#).
2. Remove the [side cover](#).
3. Remove the [front bezel](#).
4. Remove the [2.5-inch hard-drive](#).
5. Remove the [3.5-inch hard-drive](#).
6. Remove the [hard-drive and optical-drive cage](#).
7. Remove the [WLAN card](#).

About this task

The following images indicate the location of the external WLAN antennas and provide a visual representation of the removal procedure.

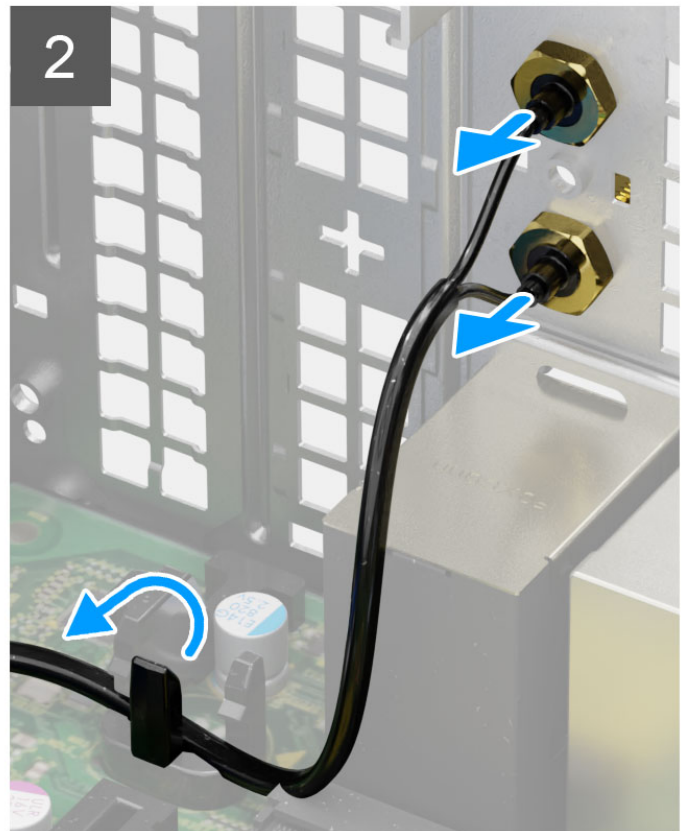
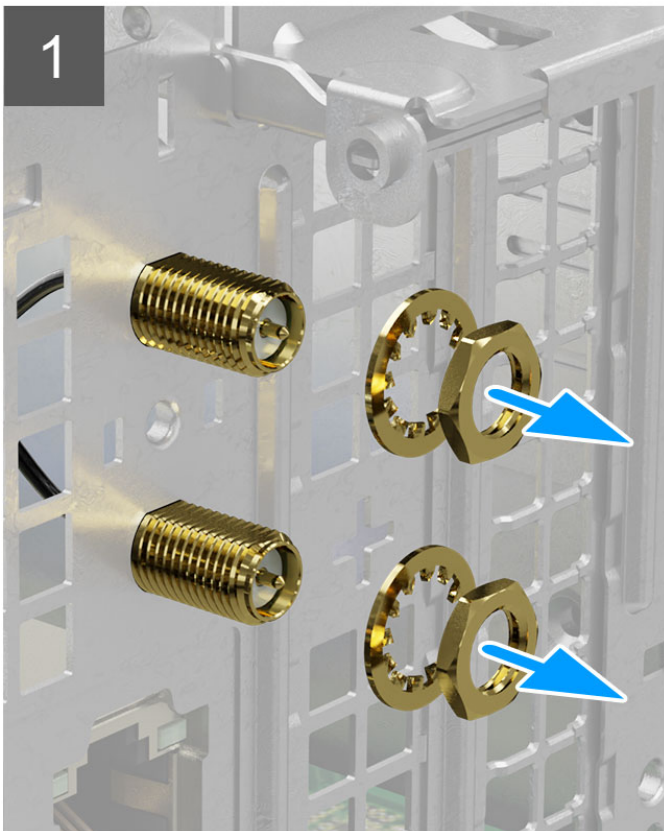

Steps

1. Remove the nut and washer from the two antenna heads.
2. Gently pry and remove the antenna heads from the chassis.
3. Remove the antenna cables from routing point on the system board.
4. Lift and remove the antenna-module from the system.

Installing the external WLAN antenna

Prerequisites

If you are replacing a component, remove the existing component before performing the installation procedure.

About this task

The following images indicate the location of the WLAN antennas and provide a visual representation of the installation procedure.

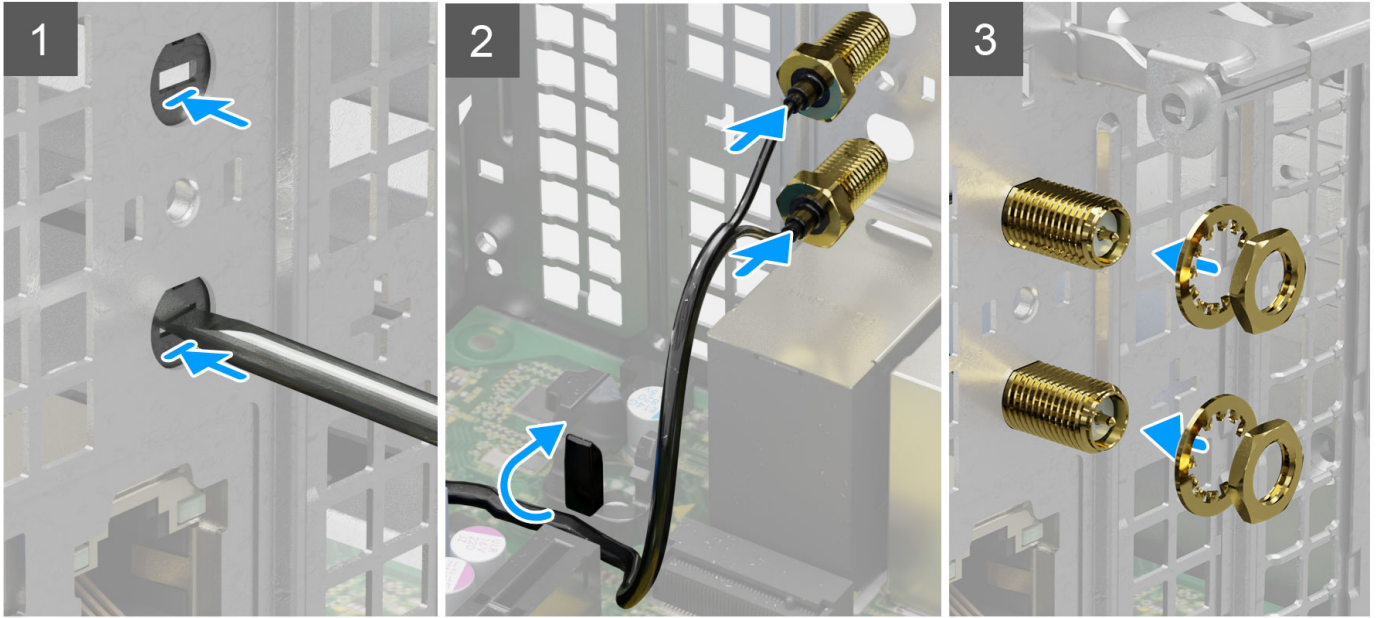

Steps

1. Push and remove the antenna cover from the chassis using a screwdriver.
i **NOTE:** This step is only applicable when the system is being upgraded to have an external WLAN antenna.
2. Route the antenna cables through the routing guides on the system board.
3. Push the antenna-modules in to the slot on the back panel of the chassis.
4. Install the nut and washer to secure the antenna-modules to the chassis.

Next steps

1. Install the [hard-drive and optical-drive cage](#).
2. Install the [WLAN card](#).
3. Install the [3.5-inch hard-drive](#).
4. Install the [2.5-inch hard-drive](#).
5. Install the [front bezel](#).
6. Install the [side cover](#).
7. Follow the procedure in [after working inside your computer](#).

Memory

Removing the memory

Prerequisites

1. Follow the procedure in [before working inside your computer](#).
2. Remove the [side cover](#).
3. Remove the [2.5-inch hard-drive](#).
4. Remove the [3.5-inch hard-drive](#).
5. Remove the [hard-drive and optical-drive cage](#).

About this task

The following images indicate the location of the memory modules and provide a visual representation of the removal procedure.

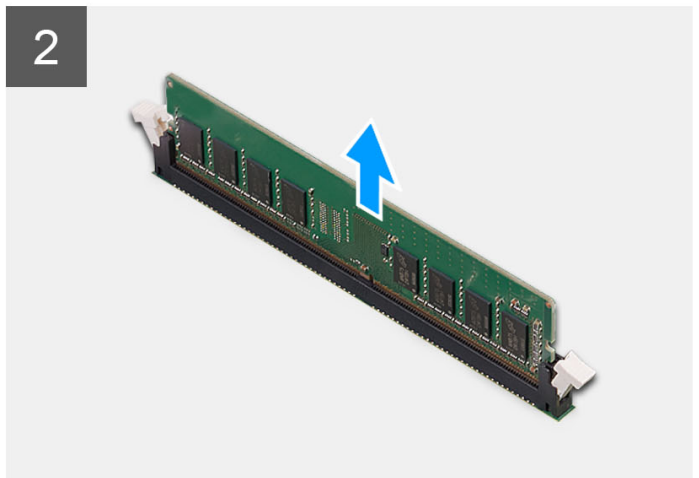
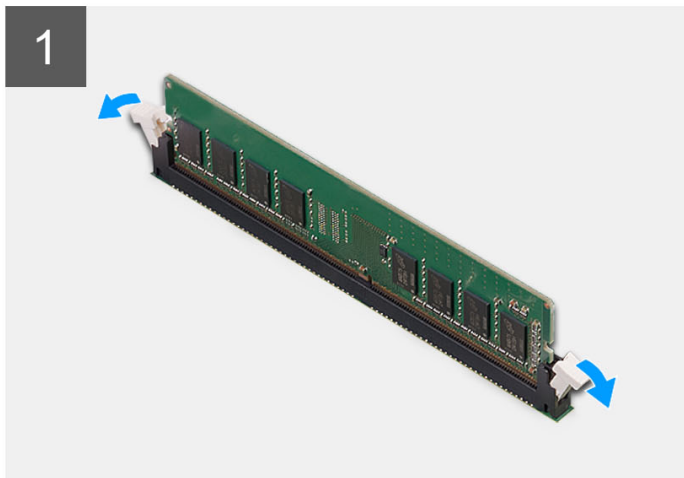
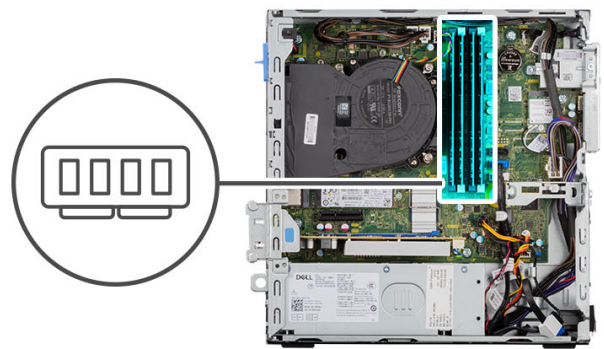

Steps

1. Carefully spread apart the securing-clips on each end of the memory-module slot.
2. Grasp the memory module near the securing clip, and then gently ease the memory module out of the memory-module slot.

CAUTION: To prevent damage to the memory module, hold the memory module by the edges. Do not touch the components on the memory module

NOTE: Repeat step 1 to step 2 to remove any other memory modules installed in your computer.

NOTE: Note the slot and the orientation of the memory module in order to replace it in the correct slot.

Installing the memory

Prerequisites

If you are replacing a component, remove the existing component before performing the installation procedure.

About this task

The following images indicate the location of the memory and provide a visual representation of the installation procedure.

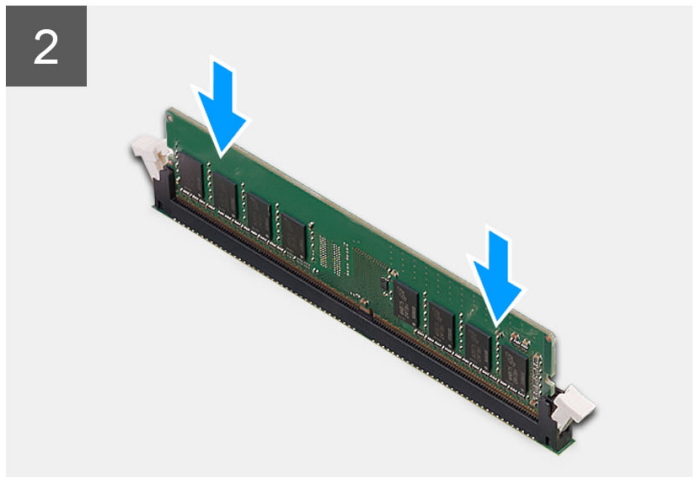
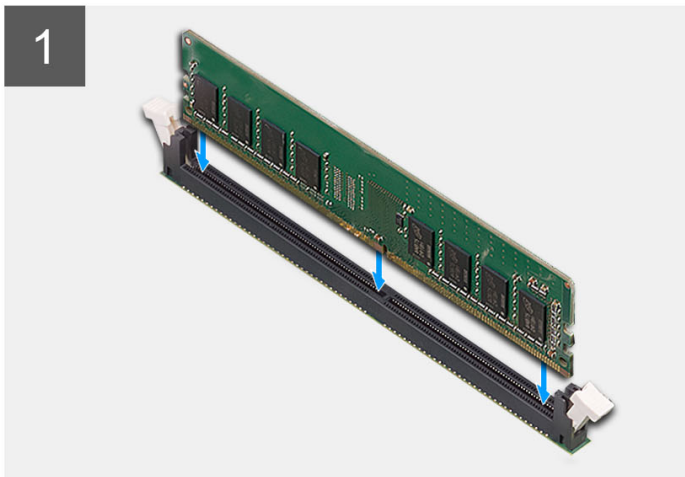
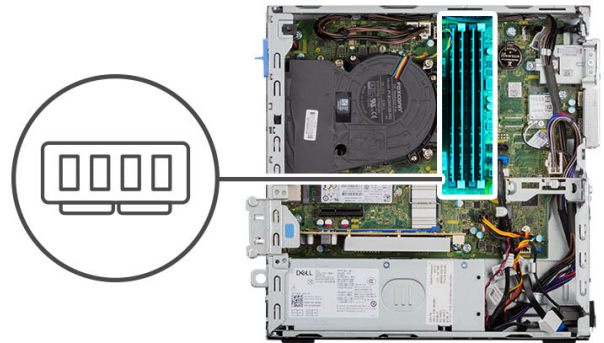

Steps

1. Ensure that the securing clips are in an open position.
2. Align the notch on the memory module with the tab on the memory-module slot.
3. Press down on the memory module until the memory module snaps into position and the securing clip locks in place.

CAUTION: To prevent damage to the memory module, hold the memory module by the edges. Do not touch the components on the memory module.

NOTE: Repeat step 1 to step 3 when installing more than one memory module in your computer.

Next steps

1. Install the [hard-drive and optical-drive cage](#).
2. Install the [3.5-inch hard-drive](#).
3. Install the [2.5-inch hard-drive](#).
4. Install the [side cover](#).
5. Follow the procedure in [after working inside your computer](#).

Processor fan and heat-sink assembly

Removing the processor fan and heat-sink assembly

Prerequisites

1. Follow the procedure in [before working inside your computer](#).
2. Remove the [side cover](#).
3. Remove the [front bezel](#).
4. Remove the [hard-drive and optical-drive bracket](#).

About this task

The following images indicate the location of the processor fan and heat-sink assembly and provide a visual representation of the removal procedure.

NOTE: The heat sink may become hot during normal operation. Allow sufficient time for the heat sink to cool before you touch it.

NOTE: For maximum cooling of the processor, do not touch the heat transfer areas on the heat sink. The oils in your skin can reduce the heat transfer capability of the thermal grease.

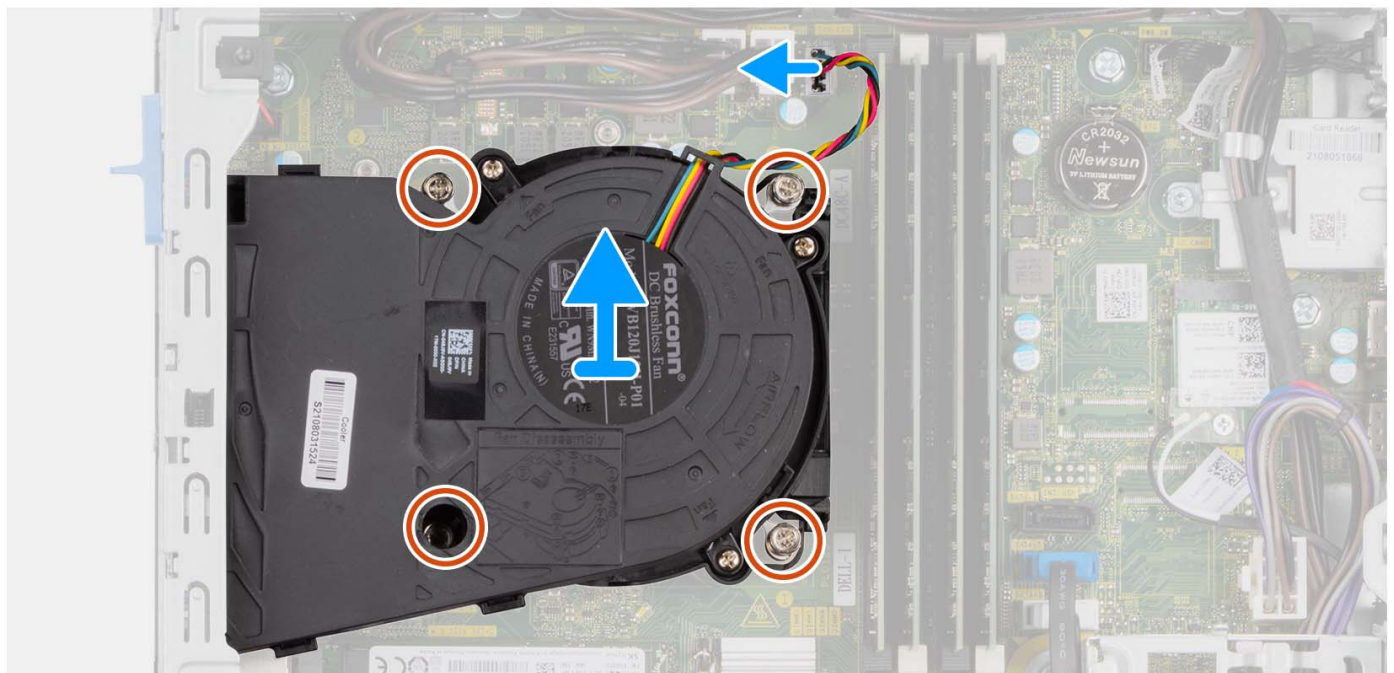

Steps

1. Disconnect the processor-fan cable from the connector on the system board.

2. Loosen the four captive screws that secure the processor fan and heat-sink assembly to the system board.
3. Lift the processor fan and heat-sink assembly from the chassis.

Installing the processor fan and heat-sink assembly

Prerequisites

If you are replacing a component, remove the existing component before performing the installation procedure.

About this task

The following image indicates the location of the processor fan and heat-sink assembly and provides a visual representation of the installation procedure.

NOTE: If either the processor or the fan and heat-sink assembly is replaced, use the thermal grease provided in the kit to ensure that thermal conductivity is achieved.

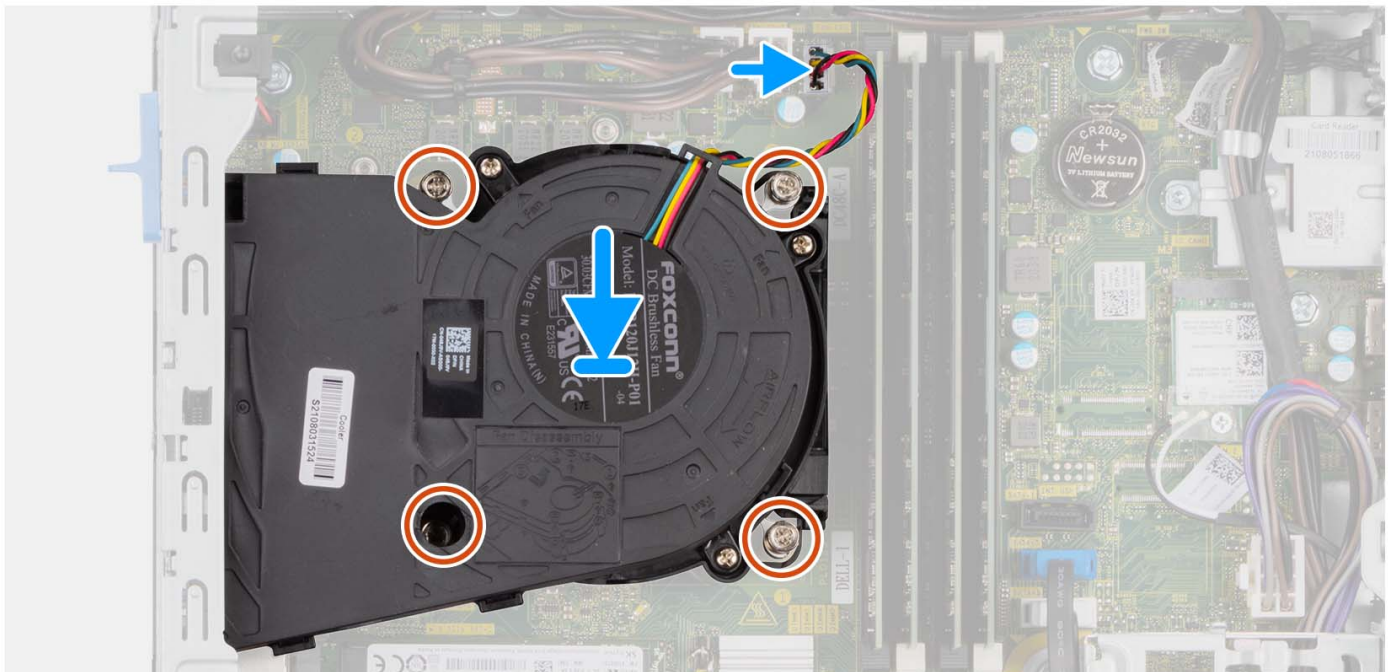
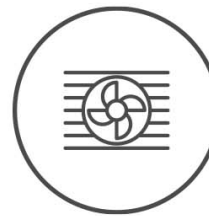

Steps

1. Place the processor fan and heat-sink assembly on the system board and align the captive screws to the screw holes on the system board.
2. Tighten the four captive screws that secure the heat sink to the system board.
3. Connect the processor-fan cable to the system board.

Next steps

1. Install the [hard-drive](#) and optical-drive bracket.
2. Install the [front bezel](#).
3. Install the [side cover](#).
4. Follow the procedure in [after working inside your computer](#).

Voltage regulator heat sink

Removing the voltage-regulator heat sink

Prerequisites

1. Follow the procedure in [before working inside your computer](#).

 **WARNING:** The heat sink may become hot during normal operation. Allow sufficient time for the heat sink to cool before you touch it.

 **CAUTION:** For maximum cooling of the processor, do not touch the heat transfer areas on the heat sink. The oils in your skin can reduce the heat transfer capability of the thermal grease.

2. Remove the [side cover](#).

About this task

The following image indicates the location of the voltage-regulator heat sink and provide a visual representation of the removal procedure.



4x

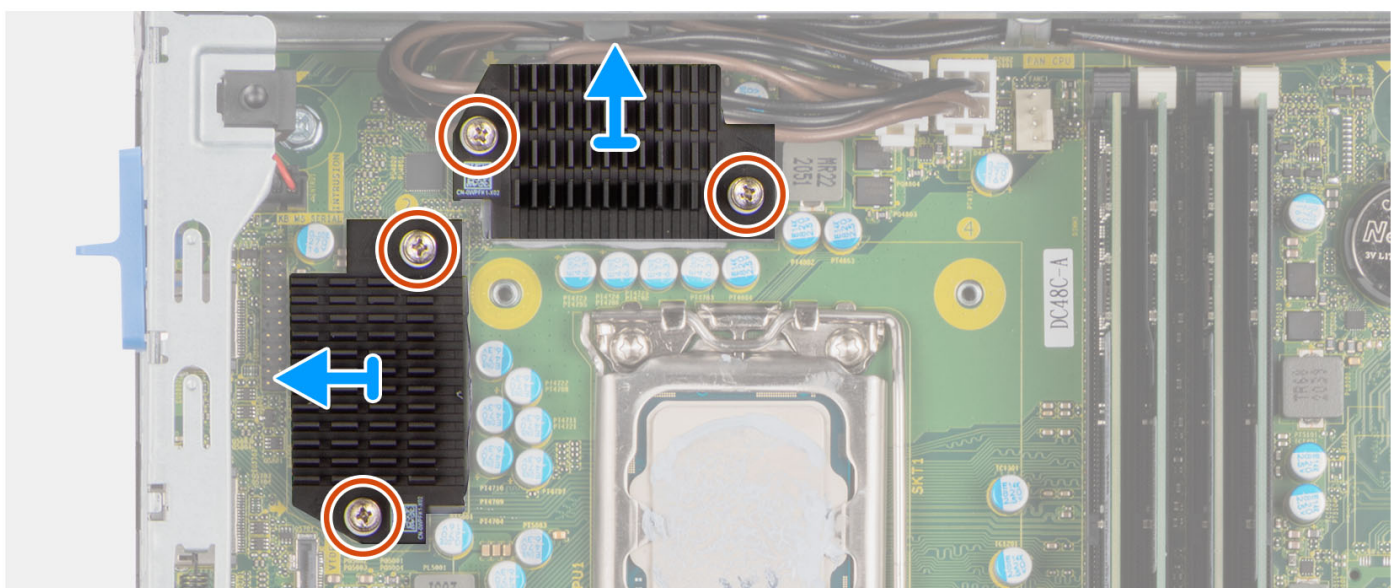

Steps

1. Loosen the four captive screws that secure the voltage-regulator heat sink to the system board.
2. Lift the voltage-regulator heat sink off the system board.

Installing the voltage-regulator heat sink

Prerequisites

If you are replacing a component, remove the existing component before performing the installation procedure.

About this task

The following image indicates the location of the voltage-regulator heat sink and provide a visual representation of the installation procedure.



4x

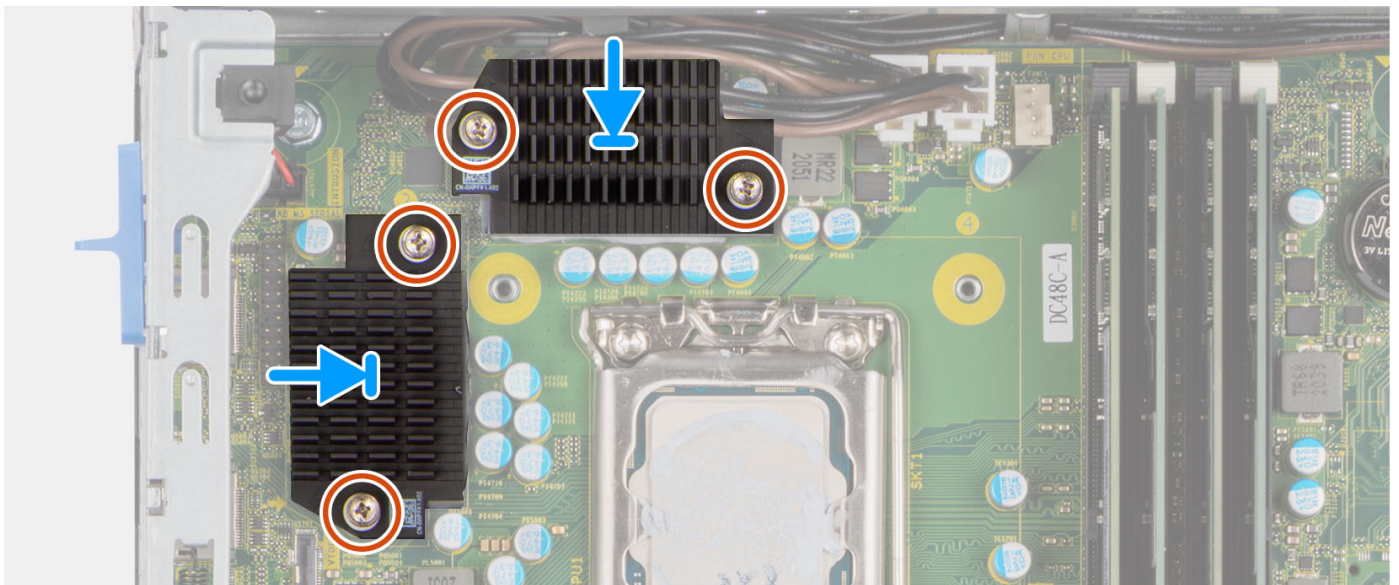

Steps

1. Place the voltage-regulator heat sink on the system board.
2. Align the captive screws on the voltage-regulator heat sink to the screw holes on the system board.
3. Tighten the four captive screws that secure the voltage-regulator heat sink to the system board.

Next steps

1. Install the [side cover](#).
2. Follow the procedure in [after working inside your computer](#).

Processor

Removing the processor

Prerequisites

1. Follow the procedure in [before working inside your computer](#).
2. Remove the [side cover](#).
3. Remove the [2.5-inch hard-drive](#).
4. Remove the [3.5-inch hard-drive](#).
5. Remove the [heat-sink and fan assembly](#).

NOTE: The processor may become hot during normal operation. Allow sufficient time for the heat sink to cool before you touch it.

About this task

The following images indicate the location of the processor and provide a visual representation of the removal procedure.

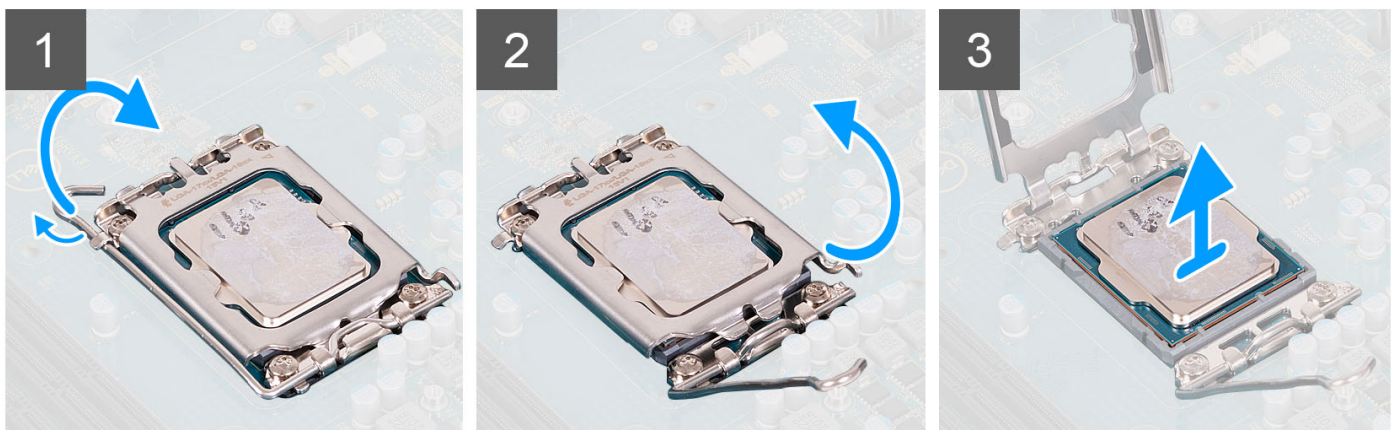
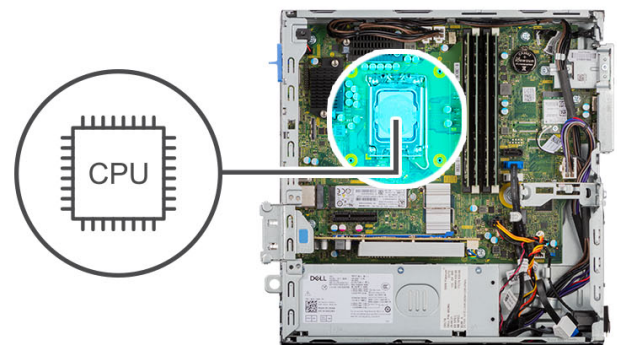

Steps

1. Press the release lever down and then push it away from the processor to release it from the securing tab.
2. Extend the release lever completely and open the processor cover.

CAUTION: When removing the processor, do not touch any of the pins inside the socket or allow any objects to fall on the pins in the socket.

3. Gently lift the processor from the processor socket.

Installing the processor

Prerequisites

If you are replacing a component, remove the existing component before performing the installation procedure.

About this task

The following image indicates the location of the processor and provides a visual representation of the installation procedure.

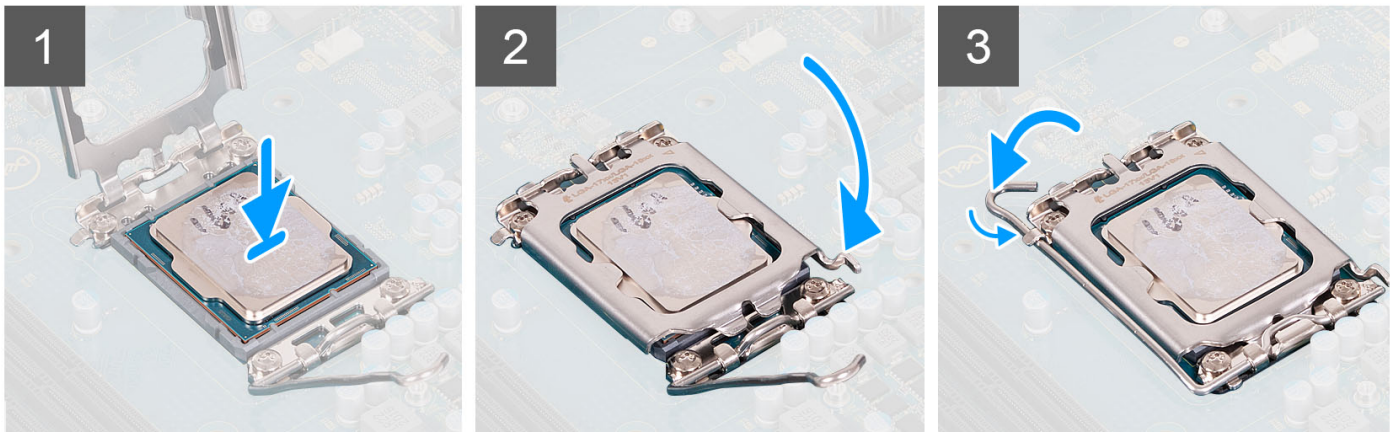
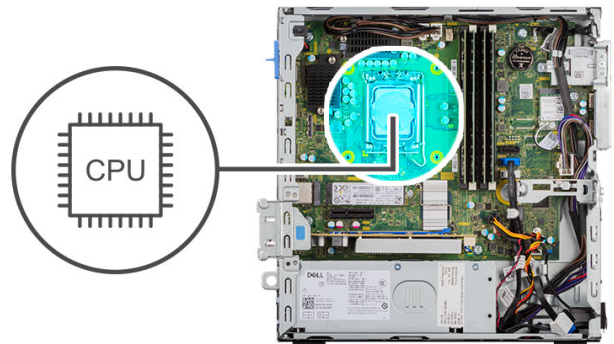

Steps

1. Ensure that the release lever on the processor socket is fully extended in the open position.
2. Align the notches on the processor with the tabs on the processor socket and place the processor in the processor socket.
 - i** **NOTE:** Ensure that the processor-cover notch is positioned underneath the alignment post.
 - i** **NOTE:** The pin-1 corner of the processor has a triangle that aligns with the triangle on the pin-1 corner on the processor socket. When the processor is properly seated, all four corners are aligned at the same height. If one or more corners of the processor are higher than the others, the processor is not seated properly.
3. When the processor is fully seated in the socket, pivot the release-lever down and place it under the tab on the processor cover.

Next steps

1. Install the [heat-sink and fan assembly](#).
2. Install the [3.5-inch hard-drive](#).
3. Install the [2.5-inch hard-drive](#).
4. Install the [front bezel](#).
5. Install the [side cover](#).
6. Follow the procedure in [after working inside your computer](#).

Expansion card

Removing the graphics card

Prerequisites

1. Follow the procedure in [before working inside your computer](#).
2. Remove the [side cover](#).

About this task

The following images indicate the location of the graphics card and provide a visual representation of the removal procedure.

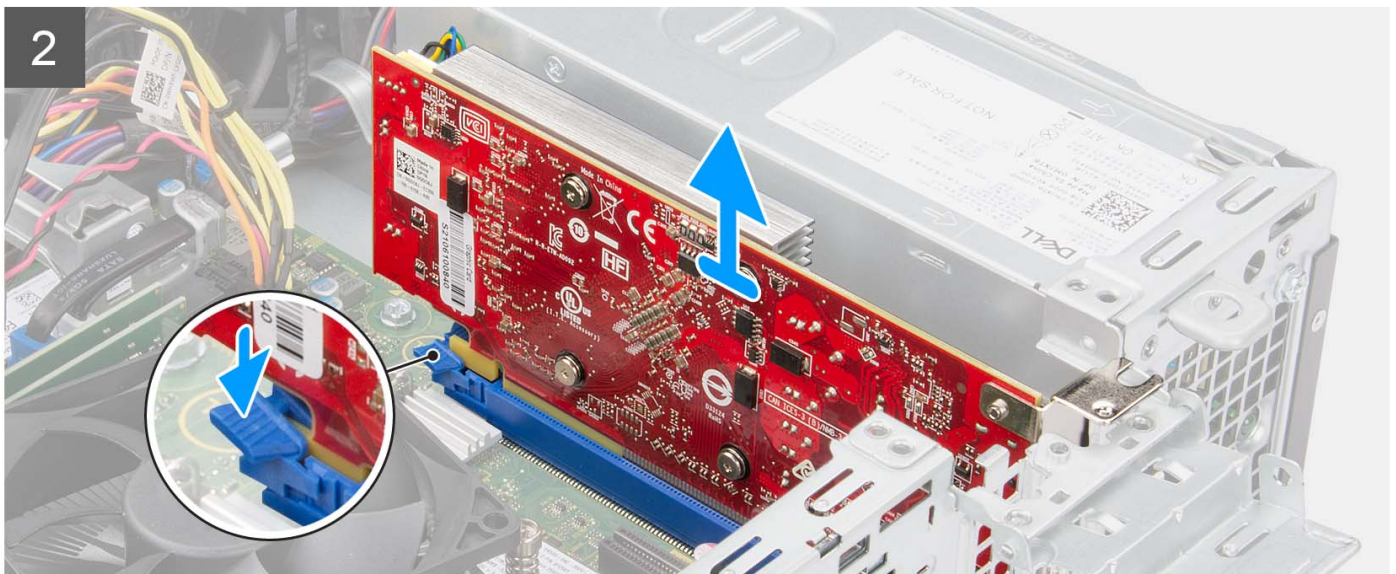
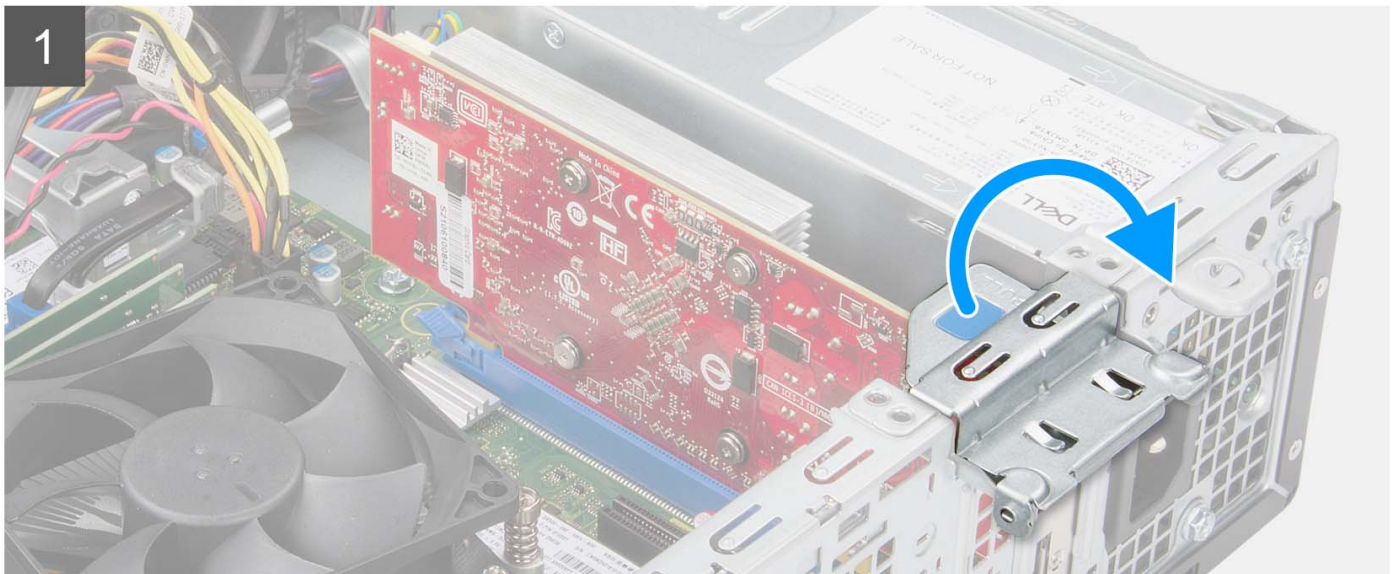

Steps

1. Using the tab, lift and open the PCIe door.
2. Push and hold the securing tab on the graphics-card slot and lift the graphics card from the PCIe x16 card slot.
3. Lift the graphics card off the system board.

Installing the graphics card

Prerequisites

If you are replacing a component, remove the existing component before performing the installation procedure.

About this task

The following image indicates the location of the graphics card and provides a visual representation of the installation procedure.

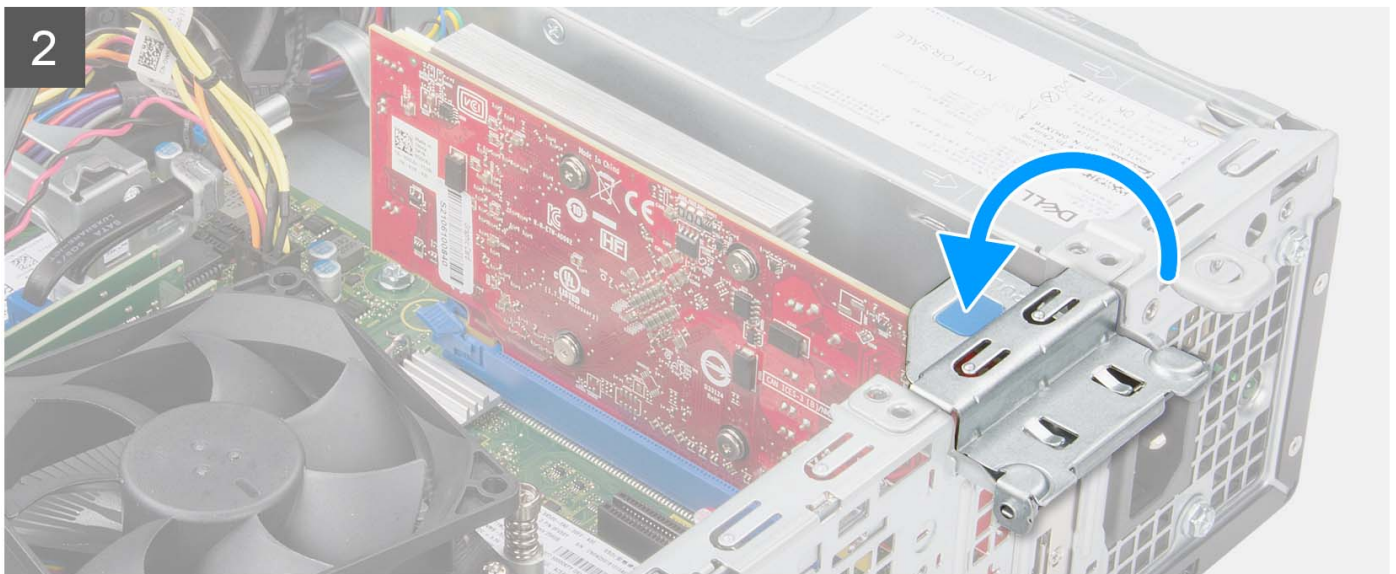
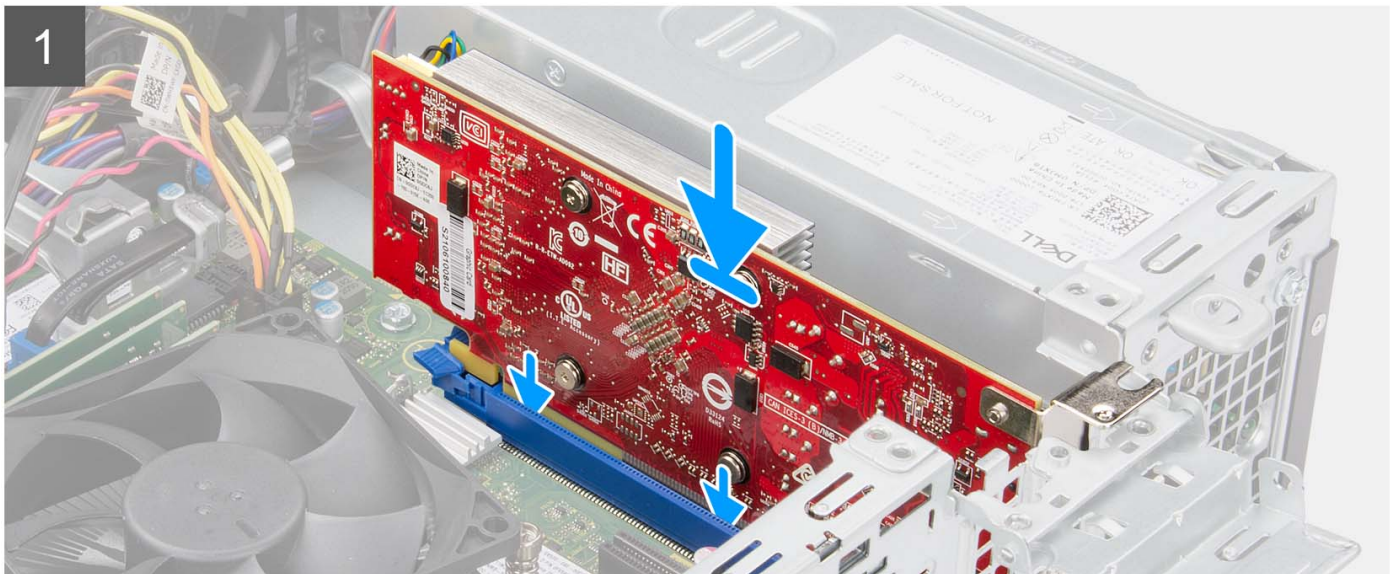

Steps

1. Align the graphics card with the PCIe x16 card slot on the system board.
2. Using the alignment post on the PCIe slot, connect the card in the connector and press down firmly. Ensure that the card is firmly seated.
3. Close the PCIe door.

Next steps

1. Install the [side cover](#).
2. Follow the procedure in [after working inside your computer](#).

Removing the Dell Ultra Speed Drive Gen 4 card

Prerequisites

1. Follow the procedure in [before working inside your computer](#).
2. Remove the [side cover](#).

About this task

The following images indicate the location of the Dell Ultra Speed Drive Gen 4 card and provide a visual representation of the removal procedure.

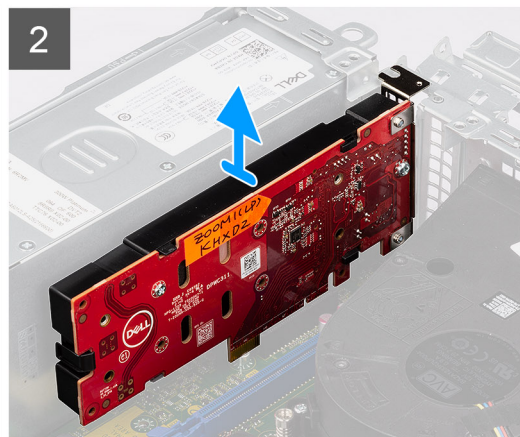
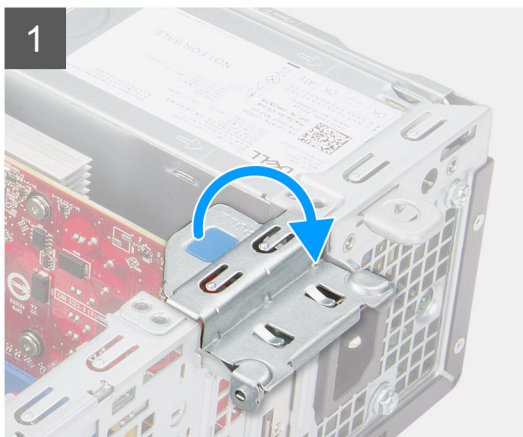

Steps

1. Lift the pull tab and open the expansion-card door.
2. Push and hold the securing tab on the PCIe slot and lift the Dell Ultra Speed Drive Gen 4 card from the PCIe x4 card slot.

Installing the Dell Ultra Speed Drive Gen 4 card

Prerequisites

If you are replacing a component, remove the existing component before performing the installation procedure.

About this task

The following image indicates the location of the Dell Ultra Speed Drive Gen 4 card and provides a visual representation of the installation procedure.

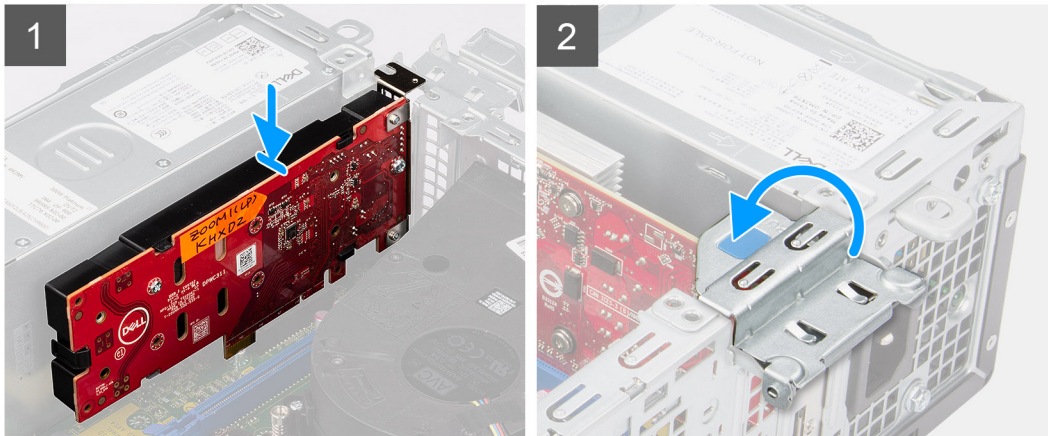

Steps

1.  **NOTE:** The Dell Ultra Speed Drive Gen4 card must be installed in the PCIe x4 slot.
Align the Dell Ultra Speed Drive Gen 4 card with the PCIe x4 card slot on the system board.
2. Using the alignment post, connect the card in the connector and press down firmly.
3. Ensure that the card is firmly seated.
4. Close the expansion-card door, and press until it clicks into place.

Next steps

1. Install the [side cover](#).
2. Follow the procedure in [after working inside your computer](#).

Optional I/O modules (PS2/Serial)

Removing optional PS2 module

Prerequisites

1. Follow the procedure in [before working inside your computer](#).
2. Remove the [side cover](#).
3. Remove the [front bezel](#).
4. Remove the [heat-sink and fan assembly](#).

About this task

The following images indicate the location of the optional PS2 module and provides a visual representation of the removal procedure.

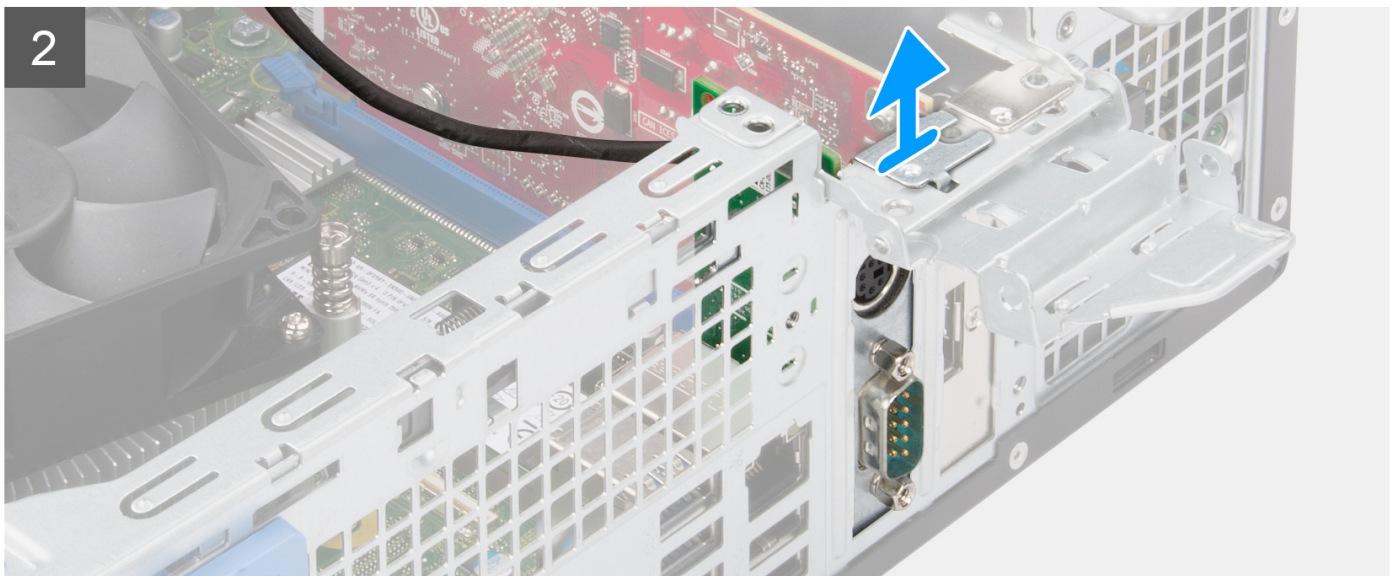
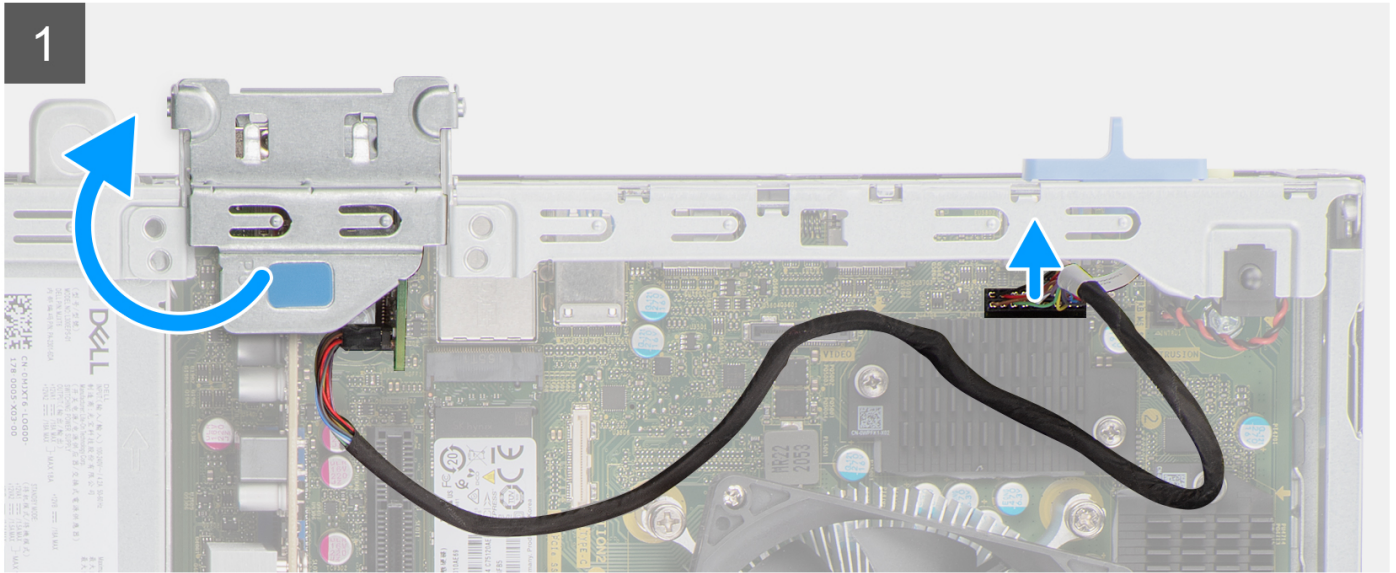

Steps

1. Lift the pull tab and open the expansion-card door.
2. Disconnect the PS2 module cable from the connector on the system board.
3. Remove the PS2 module from the computer.

Installing optional PS2 module

Prerequisites

If you are replacing a component, remove the existing component before performing the installation procedure.

About this task

The following images indicate the location of the optional PS2 module and provide a visual representation of the installation procedure.

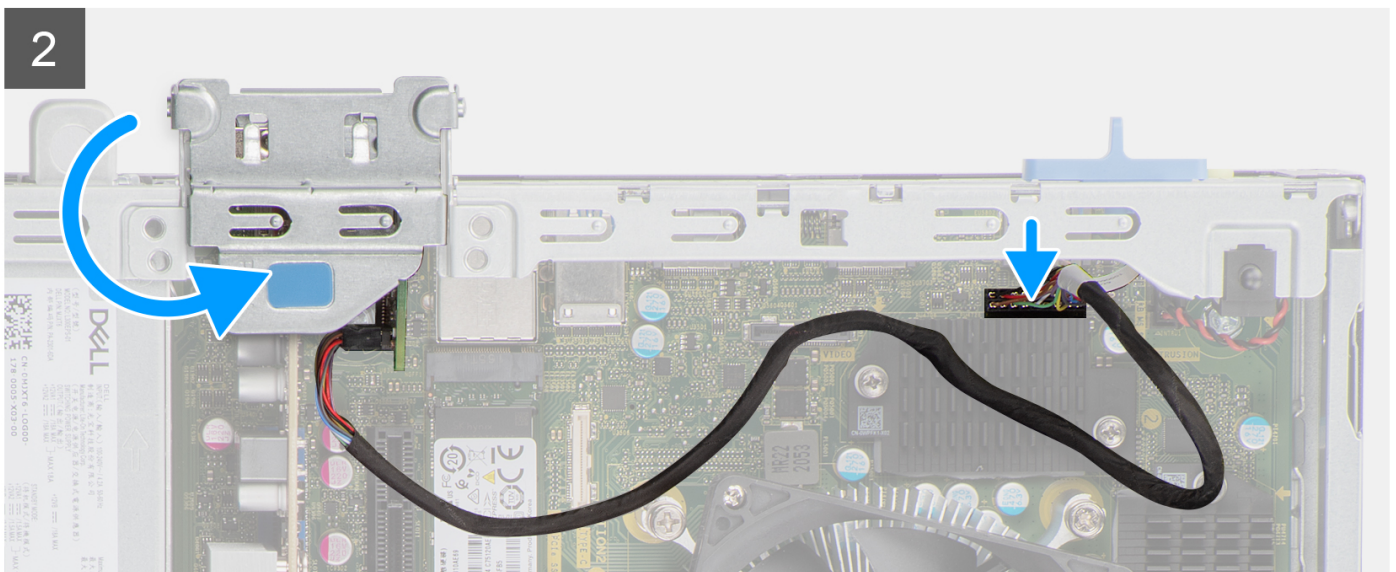
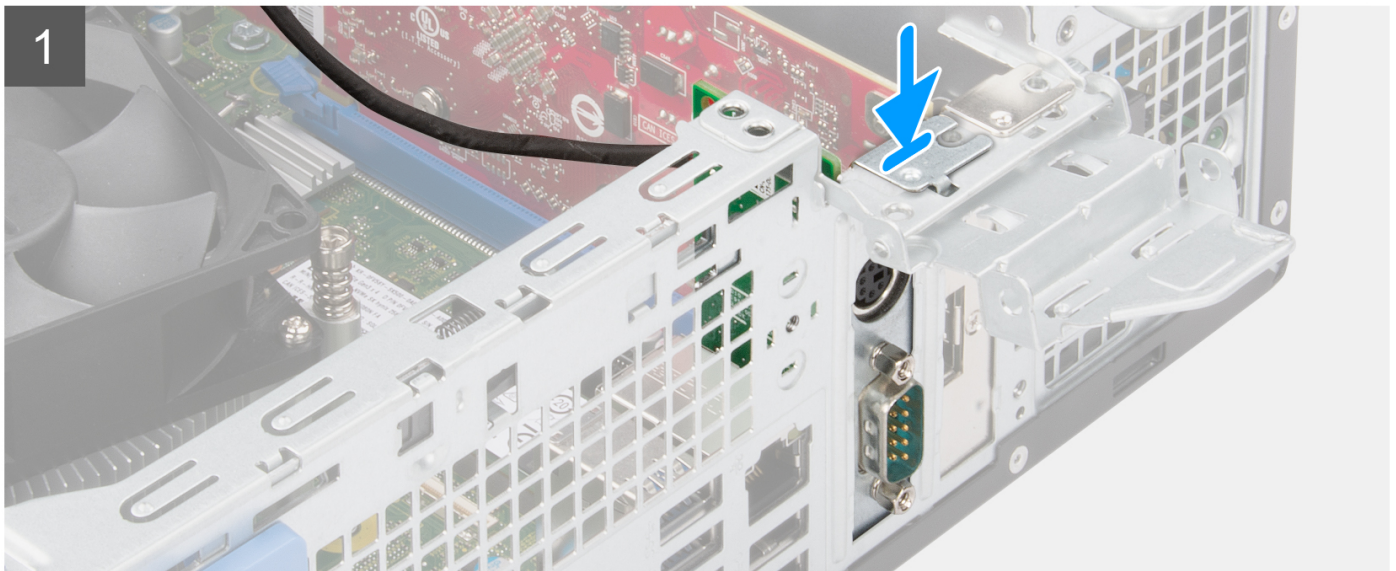

Steps

1. Insert the optional PS2 module into its slot on the chassis.
2. Connect the PS2 cable to the connector on the system board.
3. Close the expansion-card door, and press until it clicks into place.

Next steps

1. Install the [heat-sink and fan assembly](#).
2. Install the [side cover](#).
3. Follow the procedure in [after working inside your computer](#).

Optional I/O modules (VGA/HDMI/DP/USB Type-C)

Removing optional I/O module

Prerequisites

1. Follow the procedure in [before working inside your computer](#).
2. Remove the [side cover](#).
3. Remove the [front bezel](#).
4. Remove the [heat-sink and fan assembly](#).

About this task

The following images indicate the location of the optional I/O module and provides a visual representation of the removal procedure.

 **NOTE:** The removal procedure for the VGA/DP/HDMI/USB Type-C optional I/O modules are the same.

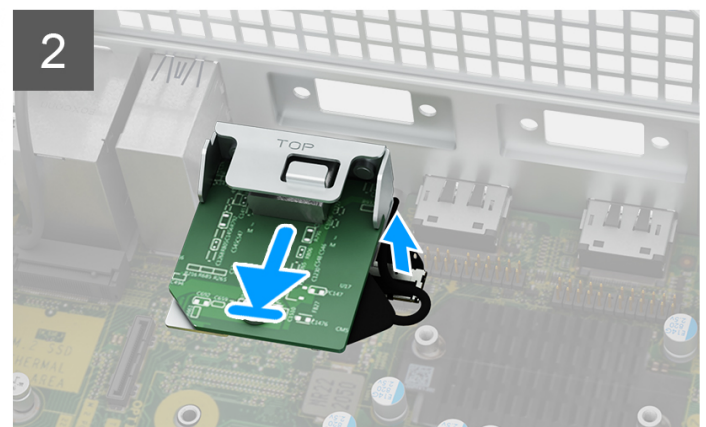
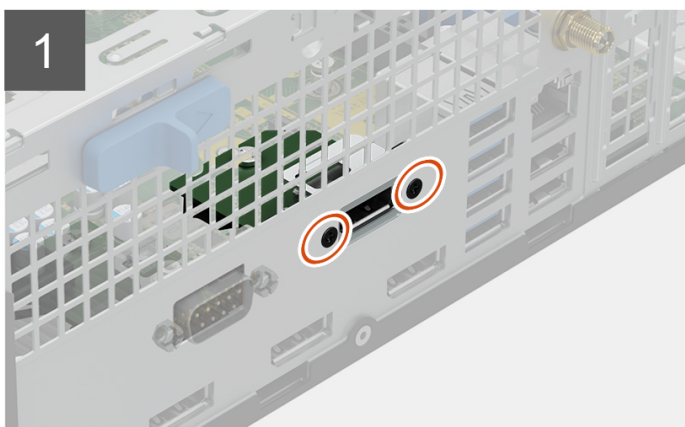

Steps

1. Remove the two screws that secure the I/O module to the chassis.

2. Disconnect the I/O-module cable from the connector on the system board.
3. Remove the I/O module from the computer.

Installing optional I/O module

Prerequisites

If you are replacing a component, remove the existing component before performing the installation procedure.

About this task

The following images indicate the location of the optional I/O module and provide a visual representation of the installation procedure.

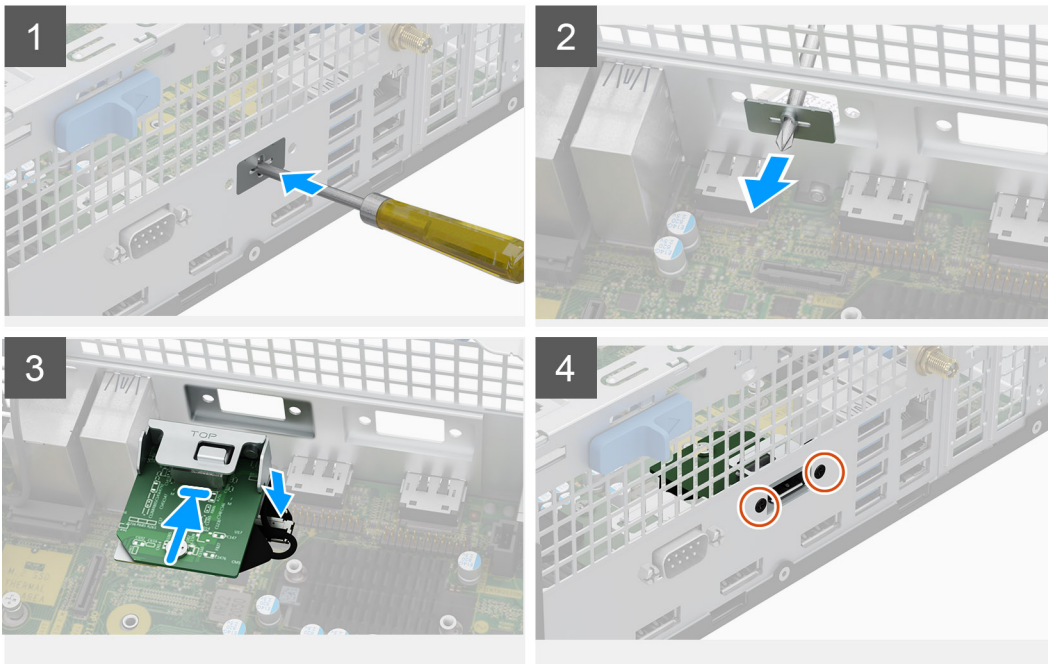

Steps

1. Using a screwdriver, remove the bracket covering the I/O module slot.

NOTE: This step is only for systems that are being upgraded with the I/O module for the first time.

2. Connect the I/O-module cable to the connector on the system board.
3. Insert the optional I/O module into its slot on the chassis.
4. Install the two screws to secure the I/O module to the chassis.

Next steps

1. Install the [heat-sink and fan assembly](#).
2. Install the [side cover](#).
3. Follow the procedure in [after working inside your computer](#).

Chassis fan

Removing the chassis fan

Prerequisites

1. Follow the procedure in [before working inside your computer](#).
2. Remove the [side cover](#).
3. Remove the [front bezel](#).
4. Remove the [2.5-inch hard-drive](#).
5. Remove the [3.5-inch hard-drive](#).
6. Remove the [hard-drive and optical-drive bracket](#).

About this task

The following image indicates the location of the chassis fan and provide a visual representation of the removal procedure.

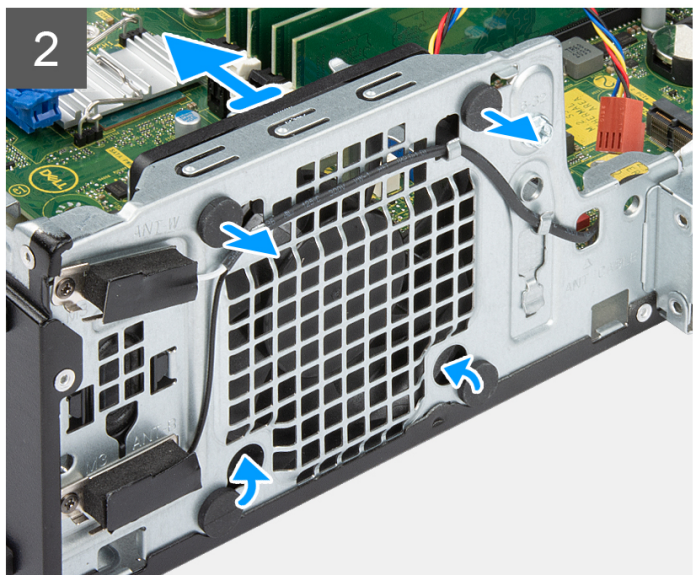
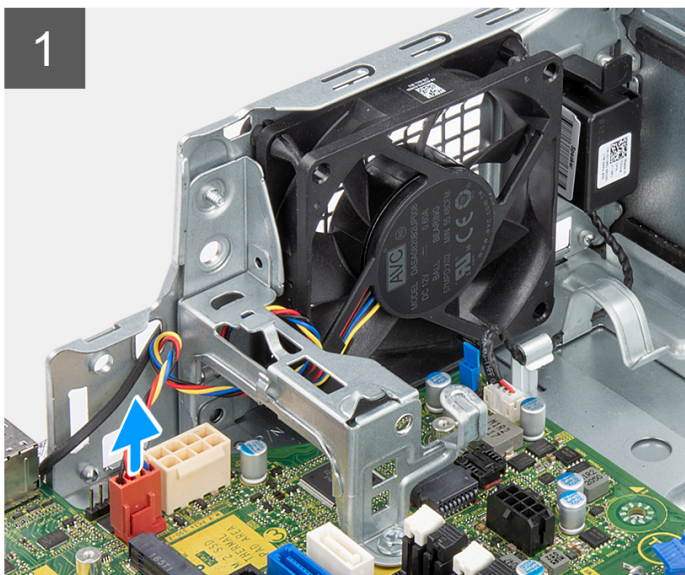

Steps

1. Disconnect the chassis fan cable from the connector on the system board.
2. Gently pull the rubber grommets to release the fan from the chassis.
3. Remove the fan off the chassis.

Installing the chassis fan

Prerequisites

If you are replacing a component, remove the existing component before performing the installation procedure.

About this task

The following image indicates the location of the chassis fan and provide a visual representation of the installation procedure.

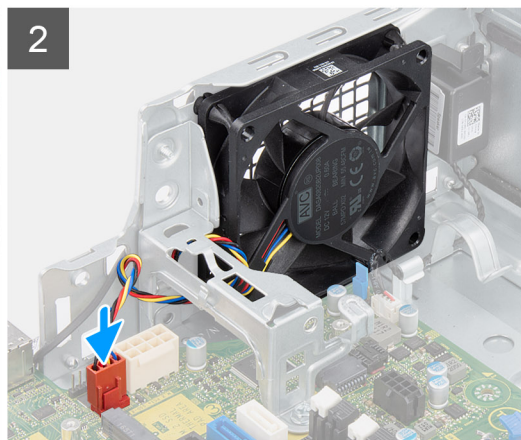
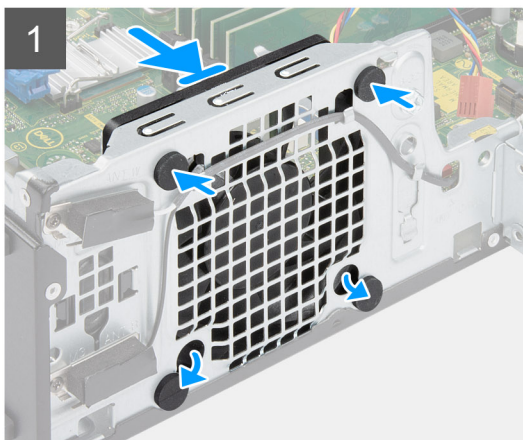

Steps

1. Insert the rubber grommets on the chassis.
2. Align the slots on the fan with the rubber grommets on the chassis.
3. Route the rubber grommets through the slots on the fan and pull the rubber grommets until the fan snaps into position.
4. Connect the fan cable to the connector on the system board.

Next steps

1. Install the [hard-drive and optical-drive bracket](#).
2. Install the [3.5-inch hard-drive](#).
3. Install the [2.5-inch hard-drive](#).
4. Install the [front bezel](#).
5. Install the [side cover](#).
6. Follow the procedure in [after working inside your computer](#).

Speakers

Removing the speaker

Prerequisites

1. Follow the procedure in [before working inside your computer](#).
2. Remove the [side cover](#).

About this task

The following images indicate the location of the speaker and provide a visual representation of the removal procedure.

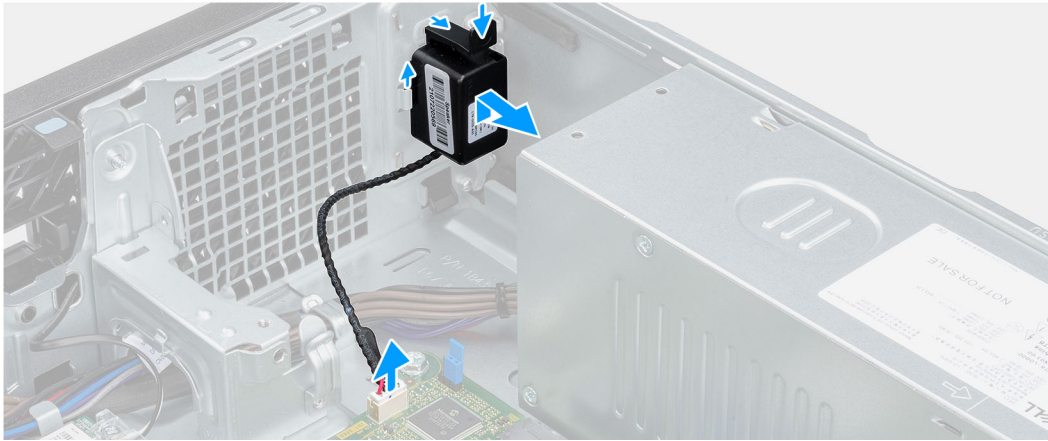

Steps

1. Disconnect the speaker cable from the connector on the system board.
2. Press the tab and slide the speaker along with the cable from the slot on the chassis.

Installing the speaker

Prerequisites

If you are replacing a component, remove the existing component before performing the installation procedure.

About this task

The following image indicates the location of the speaker and provides a visual representation of the installation procedure.

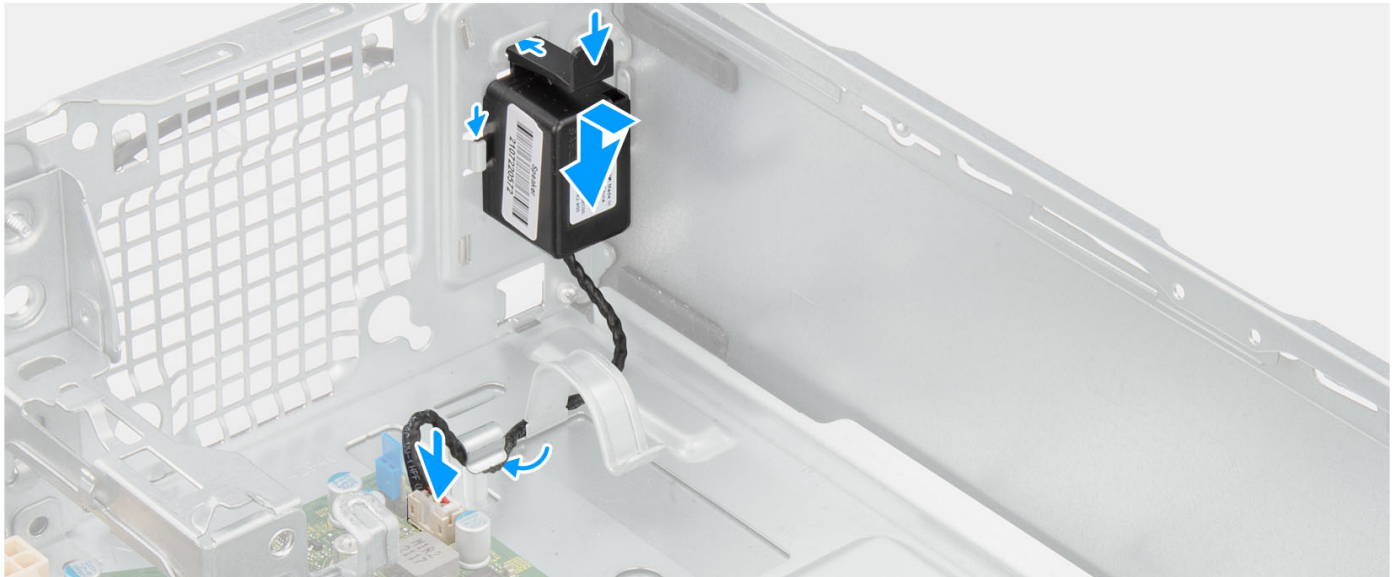

Steps

1. Press and slide the speaker in the slot on the chassis until it snaps into place.
2. Route the speaker cable through the routing guide on the chassis.
3. Connect the speaker cable to the connector on the system board.

Next steps

1. Install the [side cover](#).
2. Follow the procedure in [after working inside your computer](#).

Power-supply unit

Removing the power-supply unit

Prerequisites

1. Follow the procedure in [before working inside your computer](#).
2. Remove the [side cover](#).
3. Remove the [front bezel](#).
4. Remove the [2.5-inch hard-drive](#).
5. Remove the [3.5-inch hard-drive](#).
6. Remove the [hard-drive and optical-drive cage](#).

About this task

The following images indicate the location of the power-supply unit and provide a visual representation of the removal procedure.



3x
#6-32

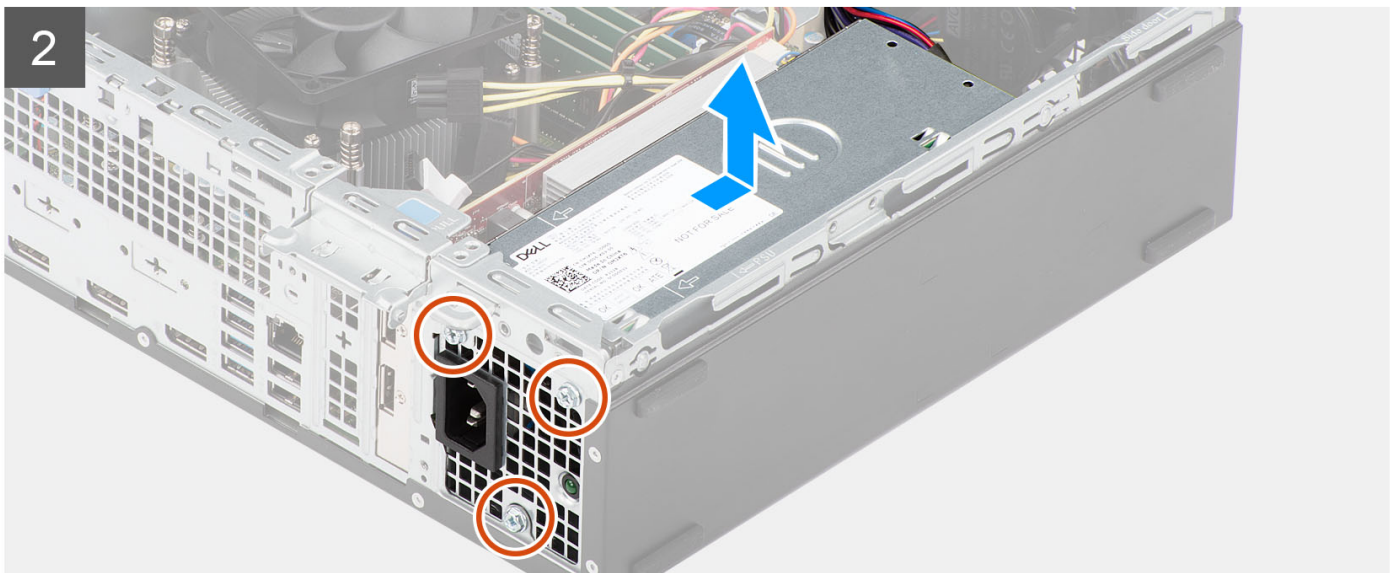
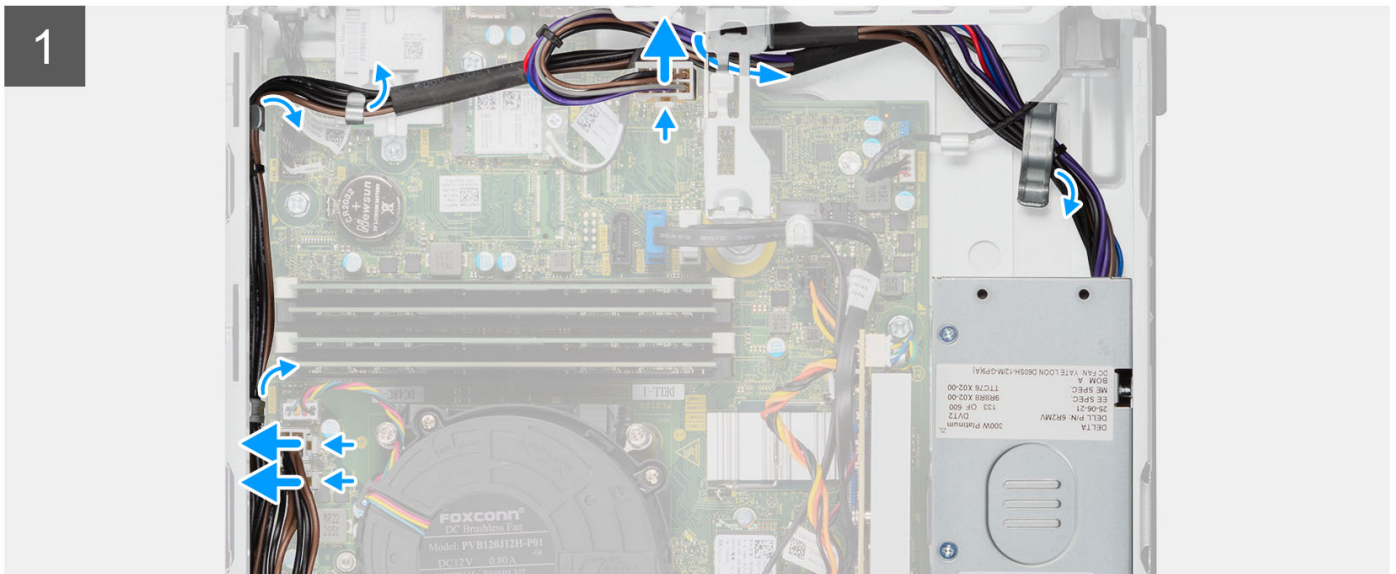
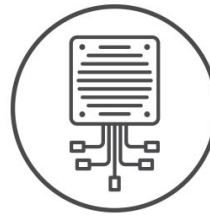

Steps

1. Disconnect the power-supply cables from the connectors on the system board.
2. Remove the power-supply cables from the routing guides on the chassis.
3. Remove the three screws (M6-32) that secure the power-supply unit to the chassis.
4. Slide and lift the power-supply unit off the chassis.

Installing the power-supply unit

Prerequisites

If you are replacing a component, remove the existing component before performing the installation procedure.

About this task

The following image indicates the location of the power-supply unit and provides a visual representation of the installation procedure.



3x
#6-32

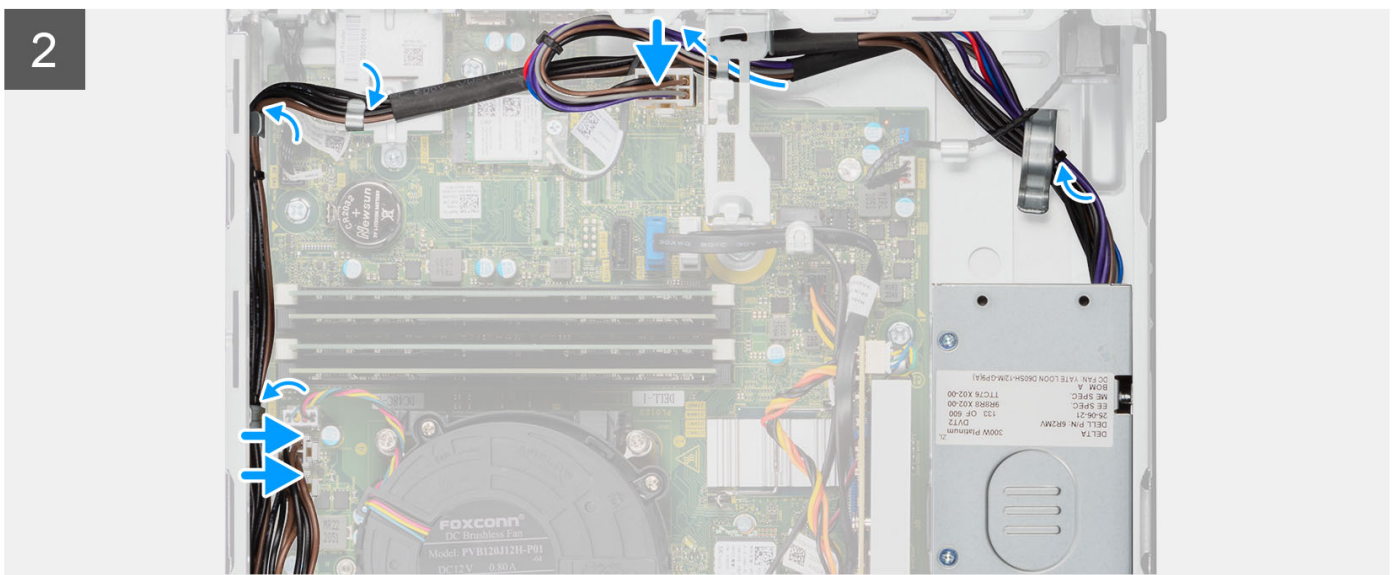
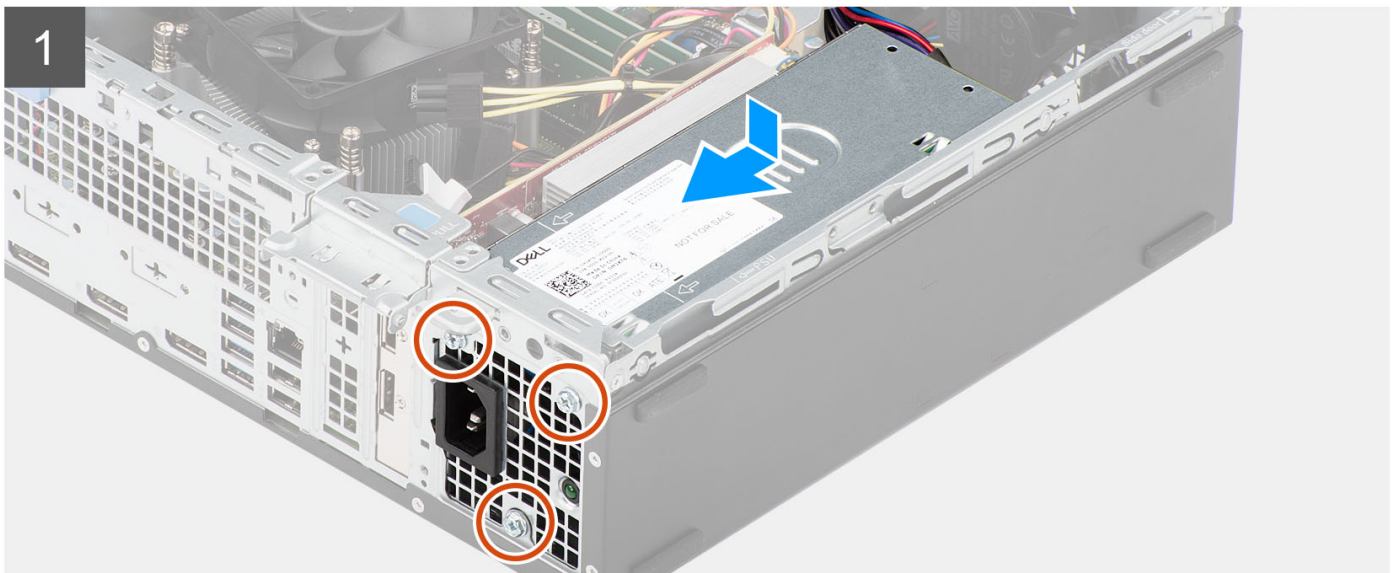
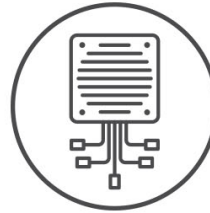

Steps

1. Place and align the screw holes on the power-supply unit to the screw holes on the chassis.
2. Replace the three (M6-32) screws to secure the power-supply unit to the chassis.
3. Route the power-supply cables through the routing guides on the chassis.
4. Connect the power-supply cables to the connectors on the system board.

Next steps

1. Install the [hard-drive and optical-drive cage](#).
2. Install the [3.5-inch hard-drive](#).
3. Install the [2.5-inch hard-drive](#).
4. Install the [front bezel](#).
5. Install the [side cover](#).
6. Follow the procedure in [after working inside your computer](#).

System board

System board callouts - 5000 Small Form Factor

The following image indicates the slots and connectors on your system board.

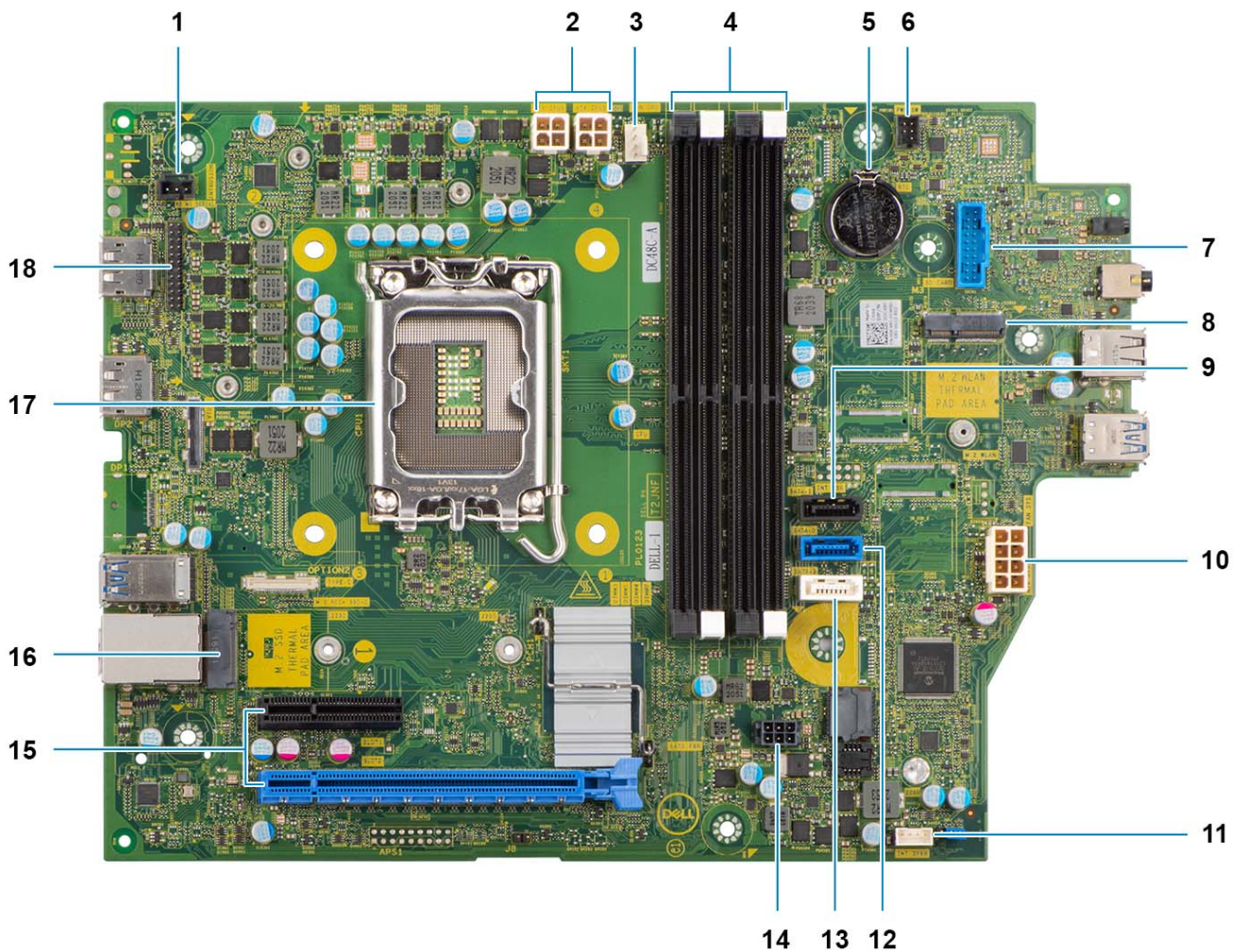

1. Intrusion-switch cable

2. Processor-power cable
3. Processor fan connector
4. UDIMM slots
From the left (a>b>c>d):
DIMM 3
DIMM 1
DIMM 4
DIMM 2
5. Coin-cell battery socket
6. Power-button cable
7. SD-card reader slot
8. M.2 WLAN slot
9. Hard-drive data cable (SATA 0)
10. System-power cable
11. Internal-speaker cable
12. Hard-drive data cable (SATA 1)
13. Optical-drive/hard-drive data cable (SATA 2)
14. SATA power cable
15. a. PCIe x16 slot (SLOT 2)
b. PCIe x4 slot (SLOT 4)
16. M.2 2230/2280 solid-state drive slot
17. Processor socket
18. I/O cable

Removing the system board

Prerequisites

1. Follow the procedure in [before working inside your computer](#).
2. Remove the [side cover](#).
3. Remove the [front bezel](#).
4. Remove the [2.5-inch hard-drive](#).
5. Remove the [3.5-inch hard-drive](#).
6. Remove the [hard-drive and optical-drive cage](#).
7. Remove the [expansion card](#).
8. Remove the [solid-state drive](#).
9. Remove the [WLAN card](#).
10. Remove the [heat-sink and fan assembly](#).
11. Remove the [memory modules](#).
12. Remove the [processor](#).

About this task

The following images indicate the location of the system board and provide a visual representation of the removal procedure.



5x
#6-32

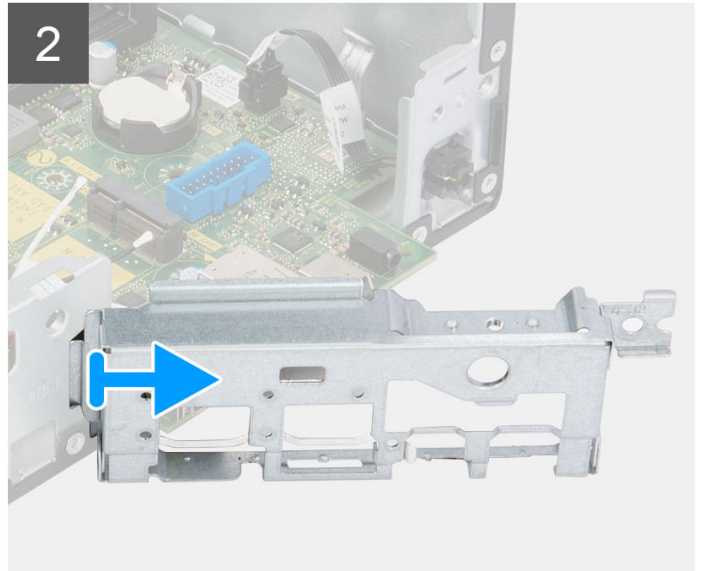
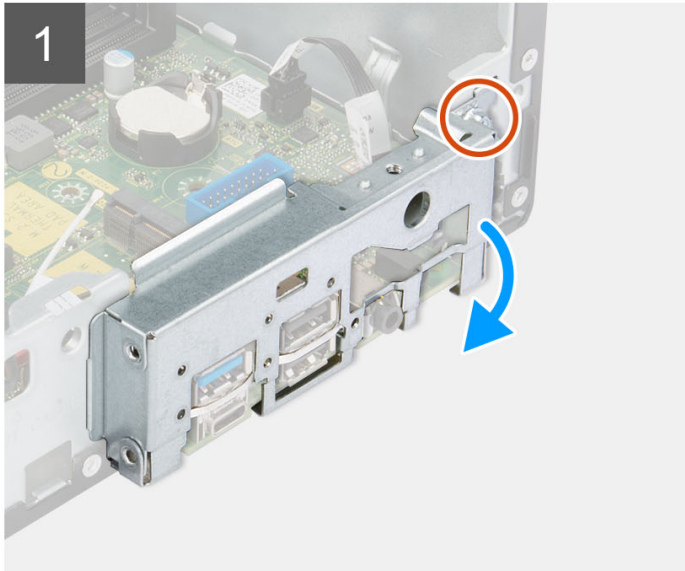

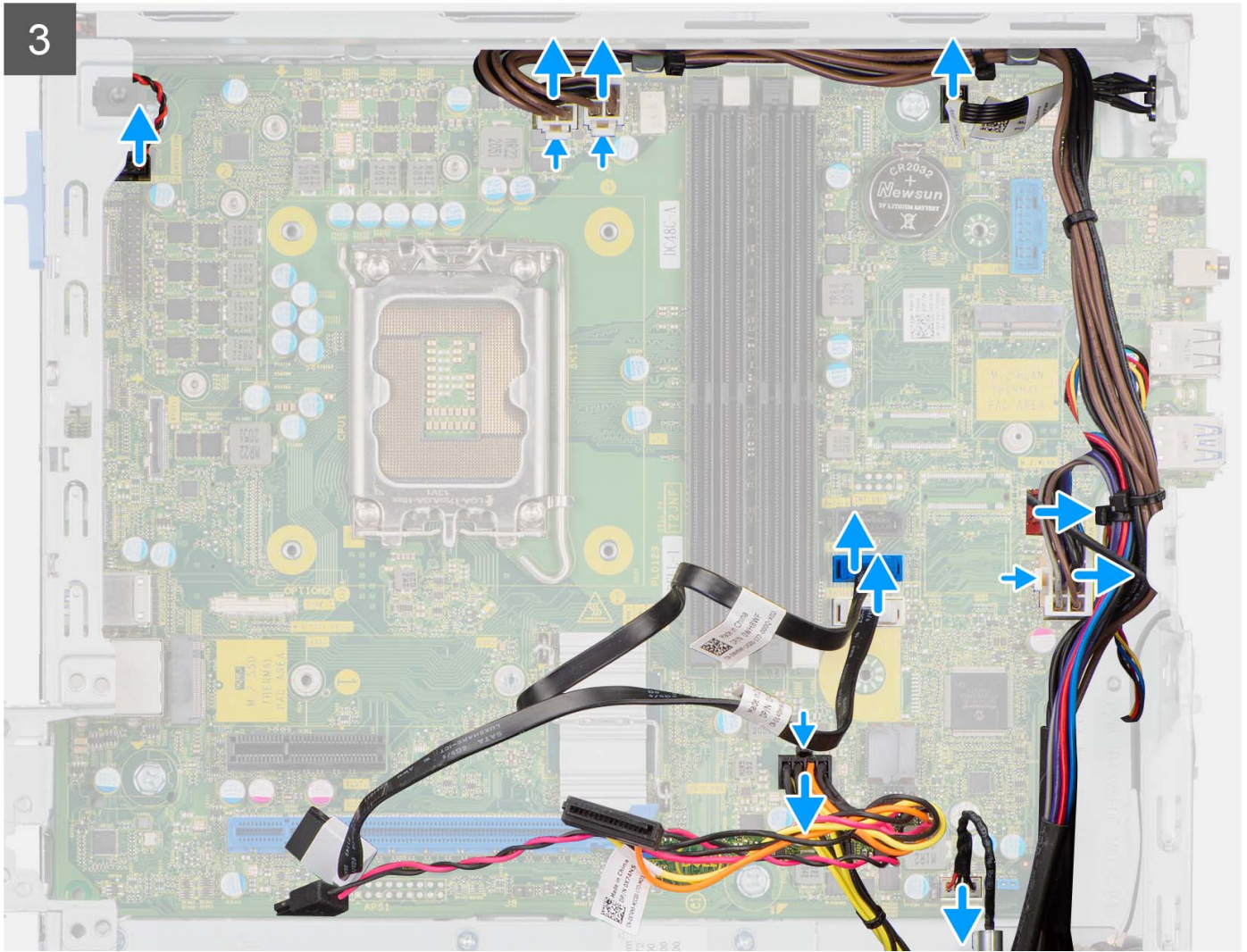

4

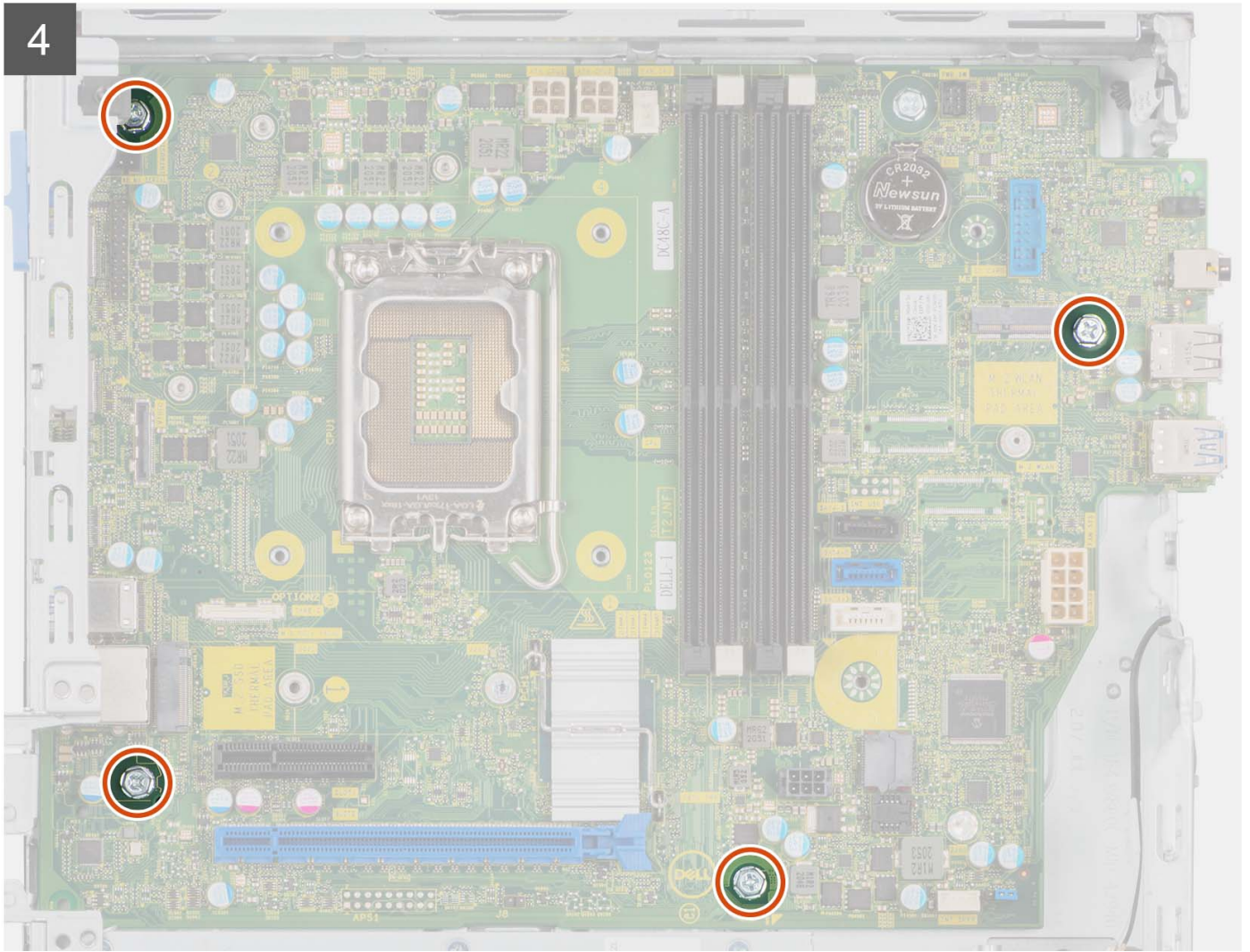

5

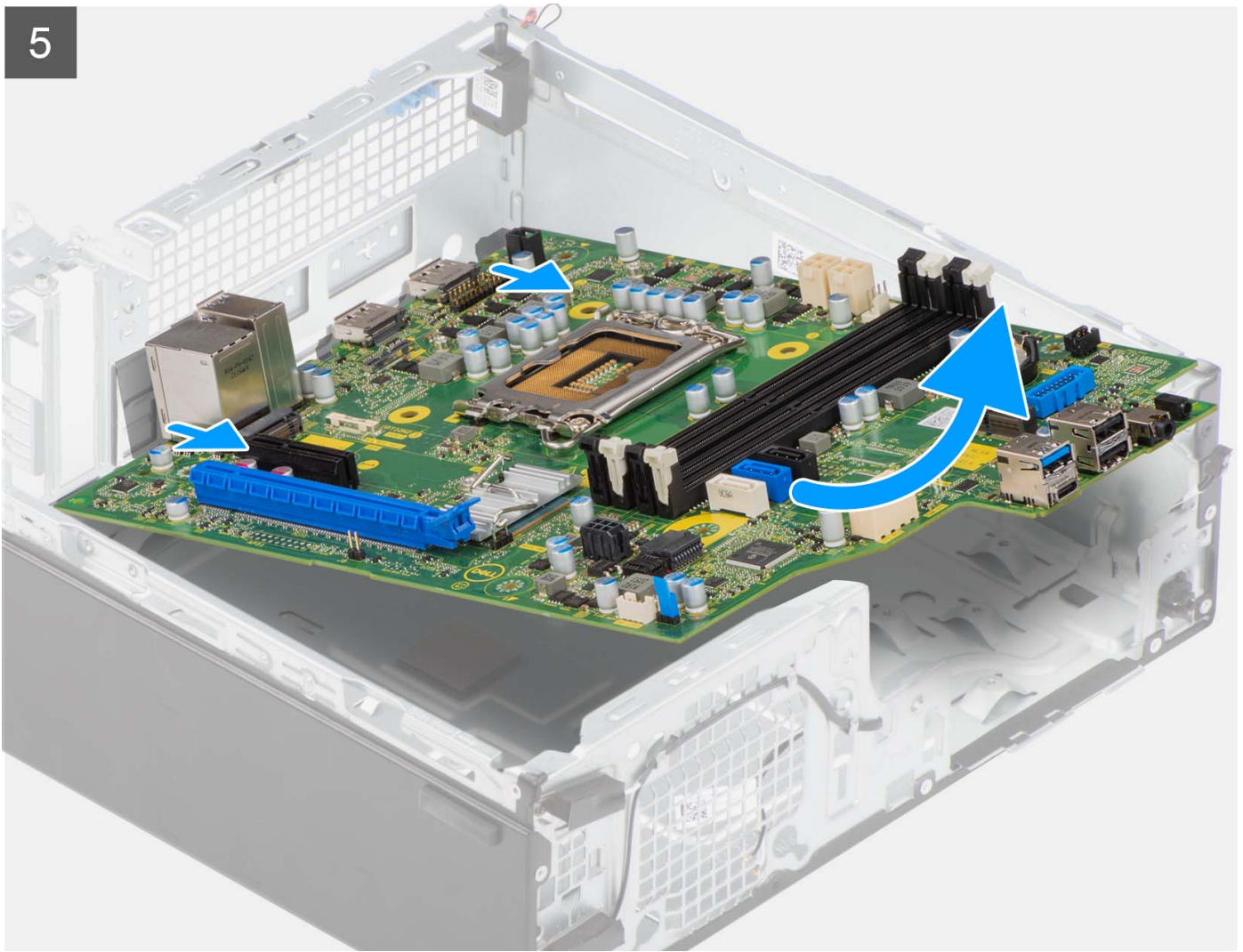

Steps

1. Remove the screw (6-32) that secures the front I/O bracket to the chassis.
2. Rotate and remove the front I/O-bracket from the chassis
3. Disconnect all the cables that are connected to the system board.
4. Remove the four screws (#6-32) that secure the system board to the chassis.
5. Free the system board from the back I/O panel by sliding it towards the right and lift the system board out of the chassis.

Installing the system board

Prerequisites

If you are replacing a component, remove the existing component before performing the installation procedure.

About this task

The following image indicates the location of the system board and provides a visual representation of the installation procedure.



5x
#6-32

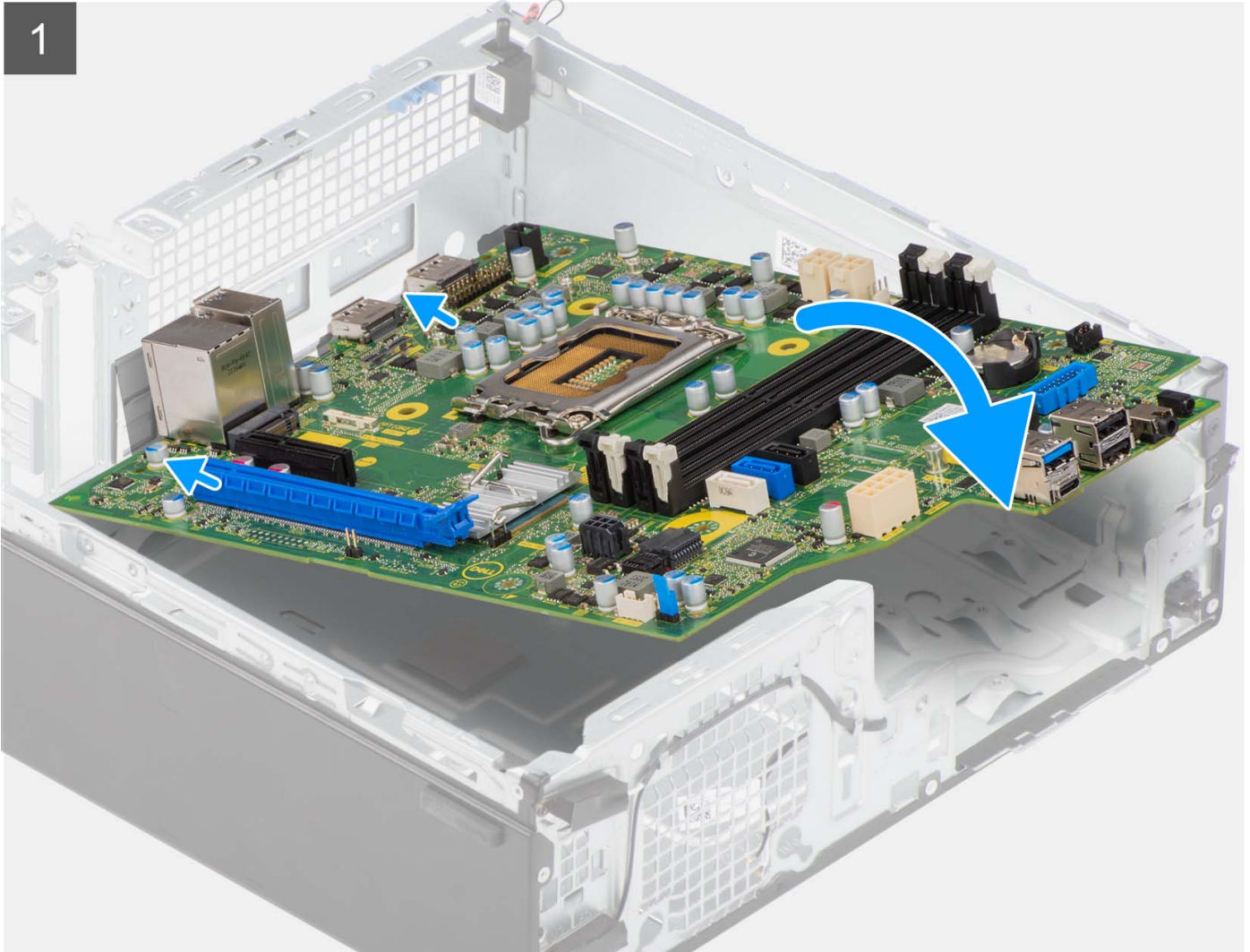

2

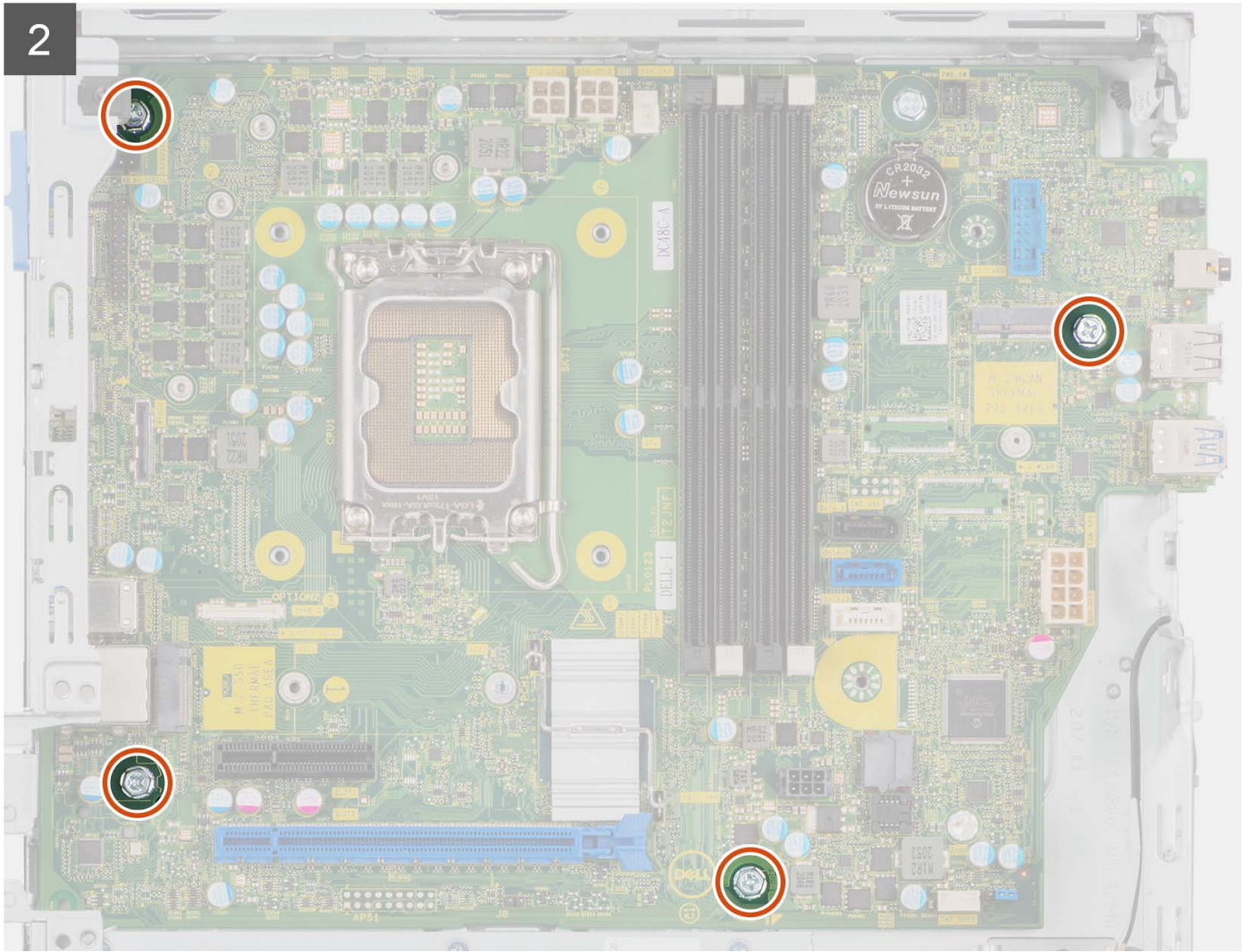

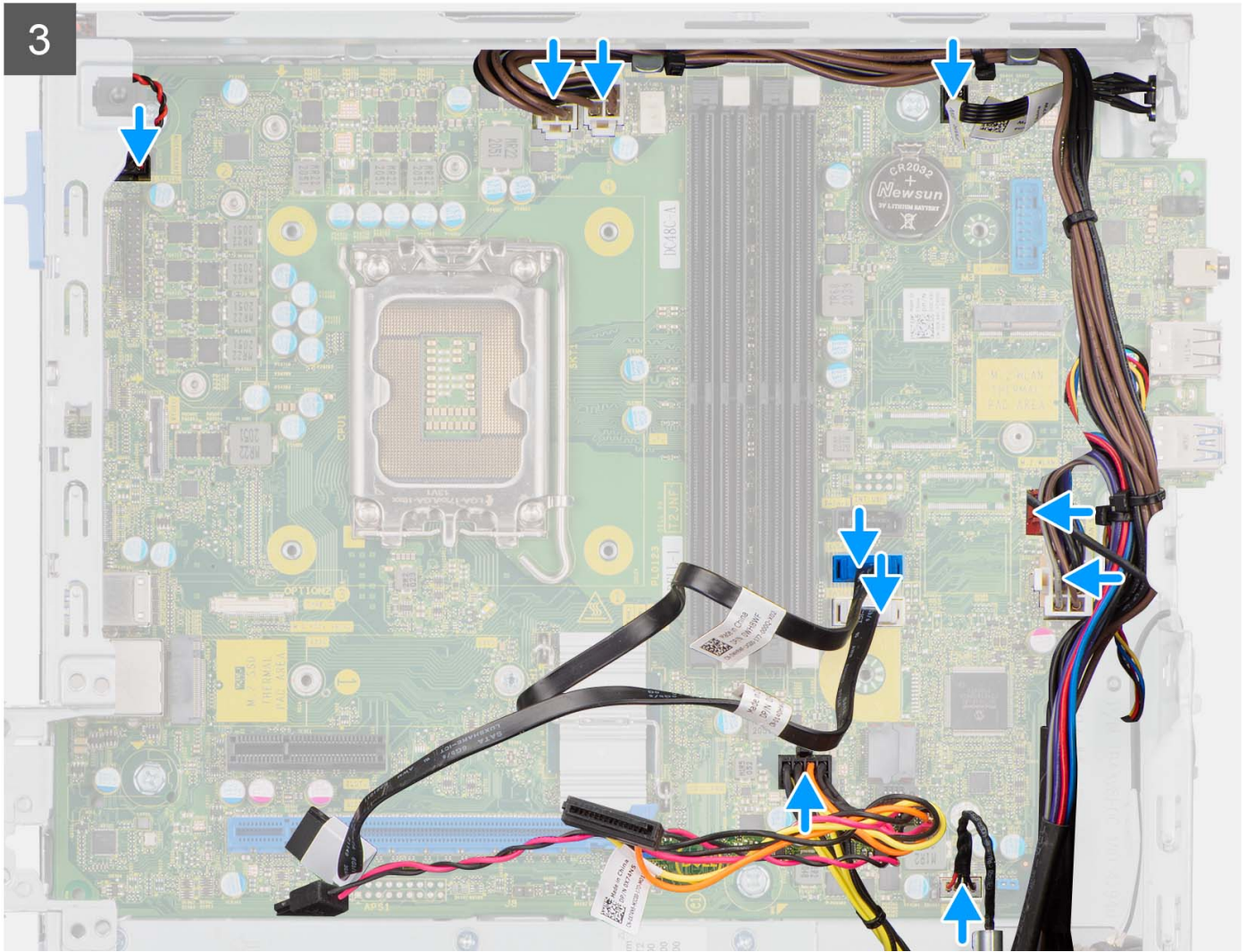

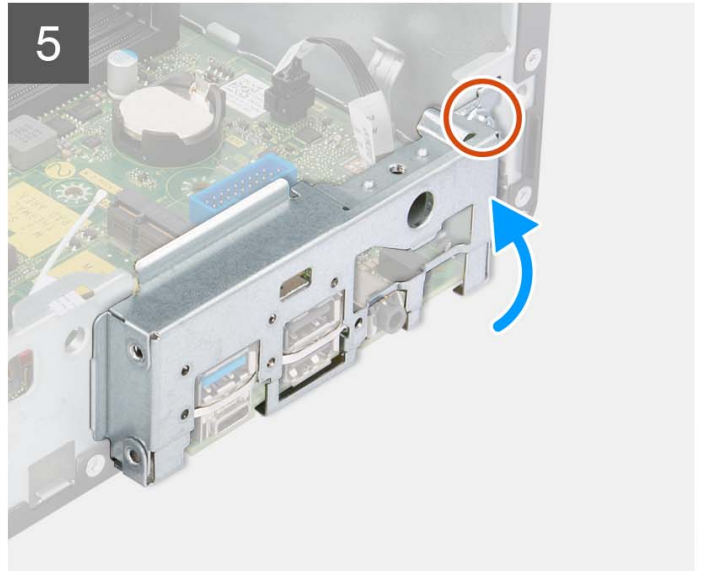
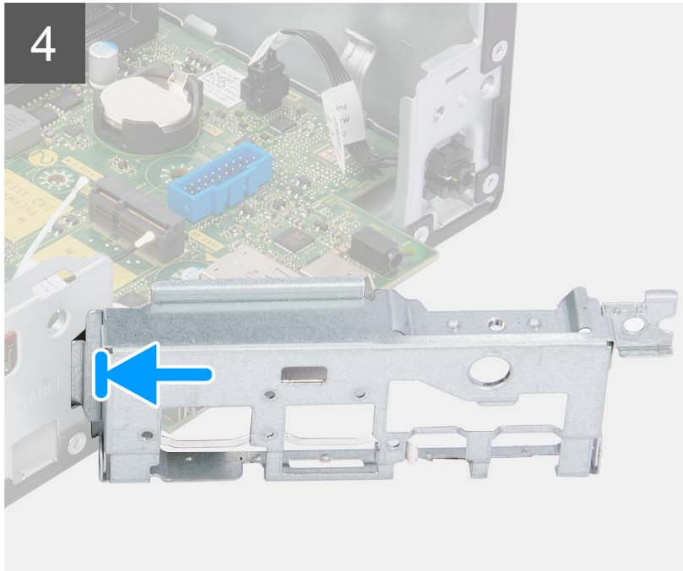

Steps

1. Align and lower the system board into the system until the stand-off points at the back of the system board align with those on the chassis.
2. Replace the four (#6-32) screws to secure the system board to the chassis.
3. Route and connect all the cables that you disconnected from the system board.
4. Place and align the front I/O-bracket with I/O slot on the chassis.
5. Replace the screw (#6-32) that secures the front I/O-bracket to the chassis.

Next steps

1. Install the [processor](#).
2. Install the [heat-sink and fan assembly](#).
3. Install the [WLAN card](#).
4. Install the [solid-state drive](#).
5. Install the [memory modules](#).
6. Install the [expansion card](#).
7. Install the [hard-drive and optical-drive cage](#).
8. Install the [3.5-inch hard-drive](#).
9. Install the [2.5-inch hard-drive](#).
10. Install the [front bezel](#).
11. Install the [side cover](#).
12. Follow the procedure in [after working inside your computer](#).

Drivers and downloads



When troubleshooting, downloading or installing drivers it is recommended that you read the Dell Knowledge Based article, Drivers and Downloads FAQ [000123347](#).

Getting help and contacting Dell

Self-help resources

You can get information and help on Dell products and services using these self-help resources:

Table 4. Self-help resources

Self-help resources	Resource location
Information about Dell products and services	www.dell.com
My Dell app	
Tips	
Contact Support	In Windows search, type <code>Contact Support</code> , and press Enter.
Online help for operating system	www.dell.com/support/windows www.dell.com/support/linux
Access top solutions, diagnostics, drivers and downloads, and learn more about your computer through videos, manuals and documents.	Your Dell computer is uniquely identified by a Service Tag or Express Service Code. To view relevant support resources for your Dell computer, enter the Service Tag or Express Service Code at www.dell.com/support . For more information on how to find the Service Tag for your computer, see Locate the Service Tag on your computer .
Dell knowledge base articles for a variety of computer concerns	<ol style="list-style-type: none"> 1. Go to www.dell.com/support. 2. On the menu bar at the top of the Support page, select Support > Knowledge Base. 3. In the Search field on the Knowledge Base page, type the keyword, topic, or model number, and then click or tap the search icon to view the related articles.

Contacting Dell

To contact Dell for sales, technical support, or customer service issues, see www.dell.com/contactdell.

 **NOTE:** Availability varies by country/region and product, and some services may not be available in your country/region.

 **NOTE:** If you do not have an active Internet connection, you can find contact information about your purchase invoice, packing slip, bill, or Dell product catalog.