



Cisco ATA 191 and ATA 192 Analog Telephone Adapter User Guide for Multiplatform Firmware

First Published: 2018-02-05

Last Modified: 2025-04-10

Americas Headquarters

Cisco Systems, Inc.
170 West Tasman Drive
San Jose, CA 95134-1706
USA
<http://www.cisco.com>
Tel: 408 526-4000
800 553-NETS (6387)
Fax: 408 527-0883

THE SPECIFICATIONS AND INFORMATION REGARDING THE PRODUCTS IN THIS MANUAL ARE SUBJECT TO CHANGE WITHOUT NOTICE. ALL STATEMENTS, INFORMATION, AND RECOMMENDATIONS IN THIS MANUAL ARE BELIEVED TO BE ACCURATE BUT ARE PRESENTED WITHOUT WARRANTY OF ANY KIND, EXPRESS OR IMPLIED. USERS MUST TAKE FULL RESPONSIBILITY FOR THEIR APPLICATION OF ANY PRODUCTS.

THE SOFTWARE LICENSE AND LIMITED WARRANTY FOR THE ACCOMPANYING PRODUCT ARE SET FORTH IN THE INFORMATION PACKET THAT SHIPPED WITH THE PRODUCT AND ARE INCORPORATED HEREIN BY THIS REFERENCE. IF YOU ARE UNABLE TO LOCATE THE SOFTWARE LICENSE OR LIMITED WARRANTY, CONTACT YOUR CISCO REPRESENTATIVE FOR A COPY.

The following information is for FCC compliance of Class A devices: This equipment has been tested and found to comply with the limits for a Class A digital device, pursuant to part 15 of the FCC rules. These limits are designed to provide reasonable protection against harmful interference when the equipment is operated in a commercial environment. This equipment generates, uses, and can radiate radio-frequency energy and, if not installed and used in accordance with the instruction manual, may cause harmful interference to radio communications. Operation of this equipment in a residential area is likely to cause harmful interference, in which case users will be required to correct the interference at their own expense.

The following information is for FCC compliance of Class B devices: This equipment has been tested and found to comply with the limits for a Class B digital device, pursuant to part 15 of the FCC rules. These limits are designed to provide reasonable protection against harmful interference in a residential installation. This equipment generates, uses and can radiate radio frequency energy and, if not installed and used in accordance with the instructions, may cause harmful interference to radio communications. However, there is no guarantee that interference will not occur in a particular installation. If the equipment causes interference to radio or television reception, which can be determined by turning the equipment off and on, users are encouraged to try to correct the interference by using one or more of the following measures:

- Reorient or relocate the receiving antenna.
- Increase the separation between the equipment and receiver.
- Connect the equipment into an outlet on a circuit different from that to which the receiver is connected.
- Consult the dealer or an experienced radio/TV technician for help.

Modifications to this product not authorized by Cisco could void the FCC approval and negate your authority to operate the product.

The Cisco implementation of TCP header compression is an adaptation of a program developed by the University of California, Berkeley (UCB) as part of UCB's public domain version of the UNIX operating system. All rights reserved. Copyright © 1981, Regents of the University of California.

NOTWITHSTANDING ANY OTHER WARRANTY HEREIN, ALL DOCUMENT FILES AND SOFTWARE OF THESE SUPPLIERS ARE PROVIDED "AS IS" WITH ALL FAULTS. CISCO AND THE ABOVE-NAMED SUPPLIERS DISCLAIM ALL WARRANTIES, EXPRESSED OR IMPLIED, INCLUDING, WITHOUT LIMITATION, THOSE OF MERCHANTABILITY, FITNESS FOR A PARTICULAR PURPOSE AND NONINFRINGEMENT OR ARISING FROM A COURSE OF DEALING, USAGE, OR TRADE PRACTICE.

IN NO EVENT SHALL CISCO OR ITS SUPPLIERS BE LIABLE FOR ANY INDIRECT, SPECIAL, CONSEQUENTIAL, OR INCIDENTAL DAMAGES, INCLUDING, WITHOUT LIMITATION, LOST PROFITS OR LOSS OR DAMAGE TO DATA ARISING OUT OF THE USE OR INABILITY TO USE THIS MANUAL, EVEN IF CISCO OR ITS SUPPLIERS HAVE BEEN ADVISED OF THE POSSIBILITY OF SUCH DAMAGES.

Any Internet Protocol (IP) addresses and phone numbers used in this document are not intended to be actual addresses and phone numbers. Any examples, command display output, network topology diagrams, and other figures included in the document are shown for illustrative purposes only. Any use of actual IP addresses or phone numbers in illustrative content is unintentional and coincidental.

All printed copies and duplicate soft copies of this document are considered uncontrolled. See the current online version for the latest version.

Cisco has more than 200 offices worldwide. Addresses and phone numbers are listed on the Cisco website at www.cisco.com/go/offices.

Cisco and the Cisco logo are trademarks or registered trademarks of Cisco and/or its affiliates in the U.S. and other countries. To view a list of Cisco trademarks, go to this URL: <https://www.cisco.com/c/en/us/about/legal/trademarks.html>. Third-party trademarks mentioned are the property of their respective owners. The use of the word partner does not imply a partnership relationship between Cisco and any other company. (1721R)

© 2025 Cisco Systems, Inc. All rights reserved.



CONTENTS

CHAPTER 1

Your ATA 1

- Your new ATA 1
- Devices associated with your ATA 1
- Cisco ATA 191 and ATA 192 Hardware 2
 - ATA 191 and ATA 192 Top Panel 2
 - Problem Report Tool Button 4
 - ATA 191 and ATA 192 Back Panel 4
- Install your new ATA 6
- Phone Adapter Configuration Utility 7
 - View MIC Cert Refresh Status 8
- Supported ATA call features 9

CHAPTER 2

New and Changed Information 11

- New and Changed for Firmware Release 11.3(1) 11
- New and Changed for Firmware Release 11.2(5) 11
- New and Changed for Firmware Release 11.2(4) 12
- New and Changed for Firmware Release 11.2(2) and 11.2(3) 12
- New and Changed for Firmware Release 11.2(1) 12

CHAPTER 3

Configure Features 13

- Phone Adapter Configuration Utility 13
- Set Up Phone Features with Phone Adapter Configuration Utility 14
- Call Forward Settings 15
- Selective Call Forward Settings 15
- Speed Dial Settings 16
- Supplementary Service Settings 17

- Distinctive Ring Settings 18
- Ring Settings 18
- Log 19
 - Debug Log Module 19
 - Debug Log Setting 19
 - Debug Log Viewer 20
 - Event Log Setting 20
 - PRT Viewer 21
 - Generate a Problem Report Remotely 21
 - PCM Viewer 22
 - CSS Dump 22
 - Crash Dump 23

CHAPTER 4

Calls 25

- Make a call from your analog phone 25
- Redial a Number from Your Analog Phone 25
- Answer a call on your ATA phone 26
- Answer call waiting on your ATA phone 26
- Put a call on hold on your analog phone 26
- Forward Your Analog Phone Calls to Another Number 27
- Transfer a Call from Your Analog Phone 27
- Make a conference call from your analog phone 28
- Call Features and Star Codes for Analog Phones 28
- Make an Emergency Call from Your Analog Phone 29
- Make a Secure Call 29

CHAPTER 5

Voice Mail 31

- Check your analog phone for new voice messages 31
- Check Your Voicemail 31

CHAPTER 6

Product Safety and Security 33

- Safety and Performance Information 33
 - Power Outage 33
 - External Devices 33

Phone Behavior During Times of Network Congestion	34
Compliance Statements	34
FCC Compliance Statements	34
FCC Part 15.21 Statement	34
FCC RF Radiation Exposure Statement	34
FCC Receivers and Class B Digital Statement	34
Compliance Information for Brazil	35
Cisco Product Security Overview	35
Important Online Information	35



CHAPTER 1

Your ATA

- [Your new ATA, on page 1](#)
- [Devices associated with your ATA, on page 1](#)
- [Cisco ATA 191 and ATA 192 Hardware, on page 2](#)
- [Install your new ATA, on page 6](#)
- [Phone Adapter Configuration Utility, on page 7](#)
- [Supported ATA call features, on page 9](#)

Your new ATA

Your analog telephone adapter (ATA) allows you to connect an analog device, such as an analog phone or fax machine, to your network. The connected device can then function like the IP phones in your network.

Your new analog telephone adapter (ATA) has two interfaces:

- Two RJ11 ports for analog devices
- A RJ45 port for Ethernet

Light-emitting diodes (LEDs) on the ATA provide status.

Install your ATA with the components that are included in the box.

You'll perform these tasks:

- Install your ATA with the components in the box.

Devices associated with your ATA

Use your ATA to connect these types of devices to your network:

- Analog phones
 - Analog phones have no softkeys.
 - The information that analog phones display depends on the model you have.
 - You use the phone's flash button for hold, resume, transfer, and conference.

- Analog telephony voice devices
 - The ATA supports analog telephony voice devices, such as overhead paging adapters and answering machines, that emulate a regular phone.
- Overhead paging systems
 - Overhead paging systems provide alarms and public-address announcements in buildings.
- Fax machines
 - Use a fax machine directly with an ATA. Don't connect an extension to a fax machine, and don't use the fax machine with a splitter.
 - To reduce fax failures, use overseas mode, if available; if not, set the fax machine transmission speed to low.
 - Data devices, such as facsimile machines and modems, may not function optimally. For the best fax and modem performance, continue to use a dedicated PSTN line.

Cisco ATA 191 and ATA 192 Hardware

The ATA 191 and ATA 192 are compact, easy to install devices.

The unit provides these connectors:

- 5V DC power connector.
- Two RJ-11 FXS (Foreign Exchange Station) ports—Your ATA has two RJ-11 ports that work with any standard analog phone device. Each port supports either voice calls or fax sessions, and both ports can be used simultaneously.
- One WAN network port—An RJ-45 10/100BASE-T data port to connect an Ethernet-capable device to the network.

The ATA 192 includes an extra LAN Ethernet port—An RJ-45 10/100BASE-T data port to connect to a device on your network, such as a computer, using an Ethernet cable.



Note The ATA network port performs autonegotiation for duplex and speed. It supports speeds of 10/100Mbps and full-duplex.

ATA 191 and ATA 192 Top Panel

The following figure shows the different LEDs and buttons found on the top of your ATA.

Figure 1: ATA 191 and ATA 192 Top Panel

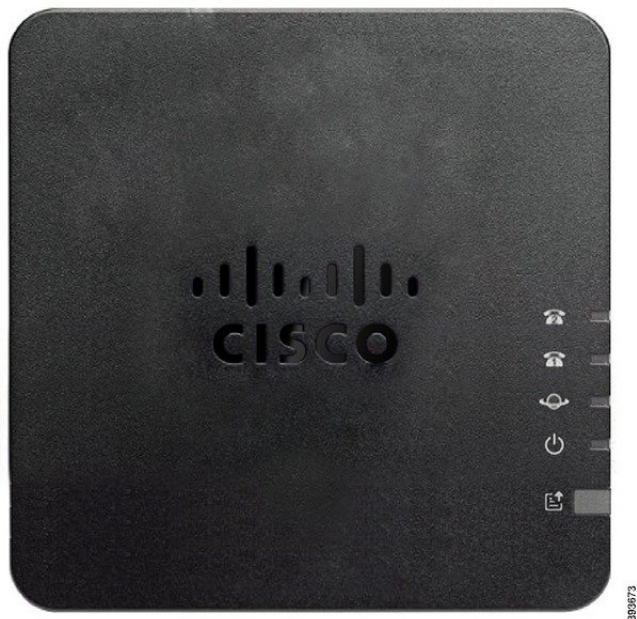







Table 1: ATA 191 and ATA 192 Top Panel Items

Item	Description
Power LED 	<p>Steady green: System booted up successfully and is ready for use.</p> <p>Slow flashing green: System is booting up.</p> <p>Fast flashing green three times, then repeats: System failed to boot up.</p> <p>Fast flashing green: The LED behaviour occurs in the following situations:</p> <ul style="list-style-type: none"> System detects a factory reset. <p>To perform a factory reset, press and hold the RESET button for about 10 seconds.</p> <ul style="list-style-type: none"> A factory reset is performed successfully. <p>Off: Power is off.</p>
Network LED 	<p>Flashing green: Data transmission or reception is in progress through the WAN port.</p> <p>Off: No link.</p>

Item	Description
Phone 1 LED Phone 2 LED 	<p>Steady green: On hook.</p> <p>Slow flashing green: Off hook.</p> <p>Fast flashing green three times, then repeats: The analog device failed to register.</p> <p>Fast flashing green: A factory reset is performed successfully.</p> <p>Off: The port is not configured.</p>
Problem Report Tool (PRT) Button 	<p>Press this button to create a problem report using the Problem Report Tool.</p> <p>Note This button is not a power button. When you press this button, a problem report is generated and uploaded to a server for the system administrator.</p>
Problem Report Tool (PRT) LED 	<p>Flashing amber: The PRT is preparing the data for the problem report.</p> <p>Fast Flashing amber: The PRT is sending the problem report log to the HTTP server.</p> <p>Solid amber: The activation of the FIPS mode failed. Press the PRT button to turn off the PRT LED.</p> <p>Solid green for five seconds, then off: The PRT report was sent successfully.</p> <p>Fast flashing green: A factory reset is performed successfully.</p> <p>Flashing red: The PRT report failed. Press the PRT button once to cancel the flashing, then press again to trigger a new PRT.</p>

Problem Report Tool Button

The Problem Report Tool (PRT) button is on the ATA top panel. Press the PRT button, and a log file is prepared and uploaded to the server for troubleshooting your network.

You can instruct your analog phone users to press the PRT button on the ATA device to start the PRT log file process.

One of the following must be completed to upload the PRT log file from the ATA:

- Set up the HTTP server to upload the PRT log file from the ATA.
- Configure the customer support upload URL to best suit your needs, and apply it to the ATA.

ATA 191 and ATA 192 Back Panel

The following figures shows the different ports and buttons found on the back of your ATA.

Figure 2: ATA 191 Back Panel



Figure 3: ATA 192—Back Panel

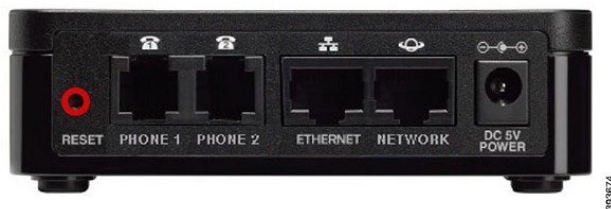

Table 2: ATA 191 and ATA 192 Back Panel Items

Item	Description
RESET	<p>To restart the ATA, use a paper clip or similar object to press this button briefly.</p> <p>To restore the factory default settings, press and hold for about 10 seconds.</p> <p>The LED behaviour for the factory reset:</p> <ol style="list-style-type: none"> 1. After you press and hold the button for about 10 seconds, the Power LED is fast flashing green. 2. After the factory reset is performed successfully, all LEDs are fast flashing green for about 5 seconds.
PHONE 1	Use an RJ-11 phone cable to connect an analog phone or fax machine.
PHONE 2	Use an RJ-11 phone cable to connect a second analog phone or fax machine.
ETHERNET (ATA 192 only)	Use an Ethernet cable to connect your ATA to a device on your network, such as a computer.
NETWORK	Use an Ethernet cable to connect to the network.
DC 5V POWER	Use the power adapter that was provided to connect to a power source.

Install your new ATA

Your ATA comes with everything to power it up, connect it to the network, and set it up on your desk.

Before you begin

Before you begin the installation, make sure you have the following equipment:

- Ethernet cable to connect to your network.
- Analog phone or fax machine to connect to your ATA.
- Phone cable to connect your phone.
- Uninterruptible power supply (UPS) to provide backup power.

Procedure

Step 1 Connect the network cable to your network and to the NETWORK port on the ATA.

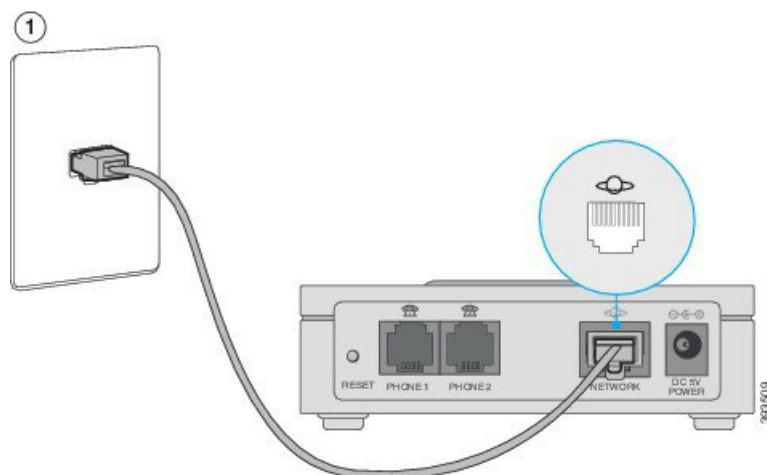

Step 2 Connect the phone cable to the PHONE 1 port on the ATA and to your analog device (phone or fax machine).

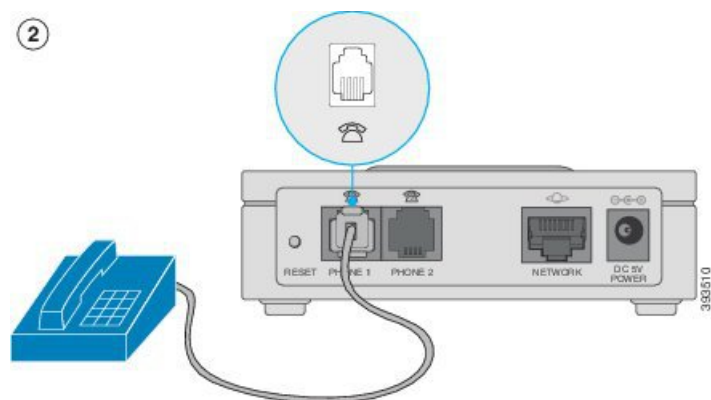

If connecting a fax machine, connect it directly to the ATA. Do not connect an extension to a fax machine, and do not use a splitter.

- Step 3** (Optional) If you have a second analog device, connect the phone cable to the PHONE 2 port on the ATA and to your second analog device.
- Step 4** Connect the ATA power cable to the DC 5V POWER port on the ATA, and plug the power cable into your power source.

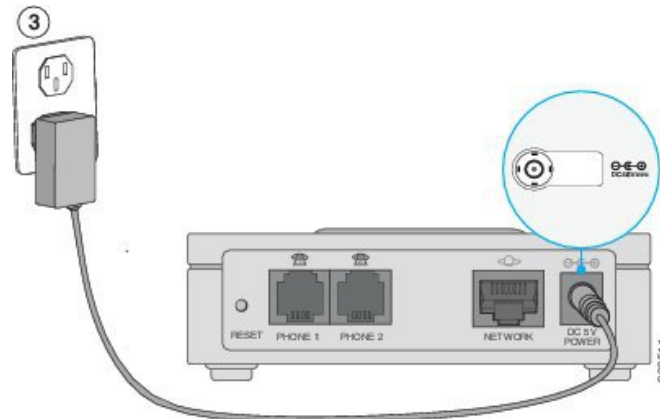

Phone Adapter Configuration Utility

You can configure or customize some phone features with the Phone Adapter Configuration Utility webpage. Your administrator gives you the page URL, your user ID, and password.

In the Configuration Utility page, you can view some network and administration settings, as well as some basic information about your ATA, such as firmware version, serial number, and memory use.

Most people use the Phone Adapter Configuration Utility page to set up a few basic features such as Speed dial or Call forward. To set up these features, refer to the following table.

The following table describes the phone features that you configure from the Phone Adapter Configuration Utility webpage.

Table 3: Configuration Utility Features

Feature	Description
Call forward and Selective call forward.	<p>You specify the number that will receive calls when call forward is enabled on the phone. Use the Configuration Utility page to set up more complicated call forward functions, for example, when your line is busy.</p> <p>For more information, see Call Forward Settings, on page 15 or Selective Call Forward Settings, on page 15 and Set Up Phone Features with Phone Adapter Configuration Utility, on page 14.</p>

Feature	Description
Speed dial.	You assign phone numbers to a line so that you can quickly call that person. For more information, see Speed Dial Settings, on page 16 and Set Up Phone Features with Phone Adapter Configuration Utility, on page 14
Supplementary services.	Configure such features as Call waiting, Do not disturb, or Called ID. For more information, see Supplementary Service Settings, on page 17 and Set Up Phone Features with Phone Adapter Configuration Utility, on page 14
Distinctive ring	You can assign a specific ring to a phone number or line. For more information, see Distinctive Ring Settings, on page 18 and Set Up Phone Features with Phone Adapter Configuration Utility, on page 14 .
Ring setting	You can assign a specific ring to a certain situation such as when a call is on hold or during a call back. For more information, see Ring Settings, on page 18 and Set Up Phone Features with Phone Adapter Configuration Utility, on page 14 .

View MIC Cert Refresh Status

You can view the MIC certificate renewal status and related information by using Phone Adapter Configuration Utility to check if the MIC certificate renewal is successful or not. If failed, your administrator might ask you about this information for troubleshooting purposes.

Before you begin

- Your administrator has given you the access to the Phone Adapter Configuration Utility.
- Your administrator activates the Manufacture Installed Certificate (MIC) renewal on your ATA.

Procedure

-
- Step 1** Sign into Phone Adapter Configuration Utility as an user.
- Step 2** Select **Voice > Information**.
- Step 3** Navigate to the section **MIC Cert Refresh Status**, and check the information.
- **MIC Cert Provisioning Status:** This field indicates that whether the certificate download is successful. If yes, the string is `Download Successful`. If no, this field shows the error message for your administrator's troubleshooting. By default, the field is empty.

- **MIC CA Info:** This field indicates that whether the MIC certificate is renewed successfully. If yes, the string is `Cisco Manufacturing CA III`. If no, this field shows `Cisco Manufacturing CA` or `Cisco Manufacturing CA II`. By default, the field is empty.

For more information about the MIC certificate renewal via a SUDI service, contact your administrator.

Supported ATA call features

Depending on your system configuration, your ATA supports some or all the following call features:

- Transfer (attended or supervised)—In this type of transfer, you talk to the receiving party before you complete the transfer.
- Transfer (unattended or unsupervised)—In this type of transfer, you complete the transfer and hang up before the receiving party answers.
- Conference.
- Hold and Resume.
- Caller ID.
- Call Waiting.
- Call Pickup.
- Speed Dial.
- Music On Hold.
- Shared Lines.
- Voicemail—This feature has no visual indicator, but a message waiting tone when you go off-hook indicates that you have voice messages. Some analog phones with a large LCD screen may display a voicemail icon.
- Call Forward.
- Redial.



CHAPTER 2

New and Changed Information

- [New and Changed for Firmware Release 11.3\(1\)](#), on page 11
- [New and Changed for Firmware Release 11.2\(5\)](#), on page 11
- [New and Changed for Firmware Release 11.2\(4\)](#), on page 12
- [New and Changed for Firmware Release 11.2\(2\) and 11.2\(3\)](#), on page 12
- [New and Changed for Firmware Release 11.2\(1\)](#), on page 12

New and Changed for Firmware Release 11.3(1)

Revision	New and Changed
New task for the feature <i>MIC Certificate Renewal</i> by <i>SUDI Service</i>	View MIC Cert Refresh Status , on page 8

New and Changed for Firmware Release 11.2(5)

Revision	New and Changed
Update the topic to add FIPS relevant information	ATA 191 and ATA 192 Top Panel , on page 2
Added the missing task about how to make a secure call	Make a Secure Call , on page 29
Updated the topic to add a table	Call Features and Star Codes for Analog Phones , on page 28

New and Changed for Firmware Release 11.2(4)

Revision	New and Changed
Added the log management relevant topics	Log , on page 19 Debug Log Module , on page 19 Debug Log Setting , on page 19 Debug Log Viewer , on page 20 Event Log Setting , on page 20 PRT Viewer , on page 21 Generate a Problem Report Remotely , on page 21 PCM Viewer , on page 22 CSS Dump , on page 22 Crash Dump , on page 23

New and Changed for Firmware Release 11.2(2) and 11.2(3)

This release doesn't affect the user guide.

New and Changed for Firmware Release 11.2(1)

Revision	New and Changed
Added a task for the E911 feature	Make an Emergency Call from Your Analog Phone , on page 29



CHAPTER 3

Configure Features

- [Phone Adapter Configuration Utility, on page 13](#)
- [Set Up Phone Features with Phone Adapter Configuration Utility, on page 14](#)
- [Call Forward Settings, on page 15](#)
- [Selective Call Forward Settings, on page 15](#)
- [Speed Dial Settings, on page 16](#)
- [Supplementary Service Settings, on page 17](#)
- [Distinctive Ring Settings, on page 18](#)
- [Ring Settings, on page 18](#)
- [Log, on page 19](#)

Phone Adapter Configuration Utility

You can configure or customize some phone features with the Phone Adapter Configuration Utility webpage. Your administrator gives you the page URL, your user ID, and password.

In the Configuration Utility page, you can view some network and administration settings, as well as some basic information about your ATA, such as firmware version, serial number, and memory use.

Most people use the Phone Adapter Configuration Utility page to set up a few basic features such as Speed dial or Call forward. To set up these features, refer to the following table.

The following table describes the phone features that you configure from the Phone Adapter Configuration Utility webpage.

Table 4: Configuration Utility Features

Feature	Description
Call forward and Selective call forward.	<p>You specify the number that will receive calls when call forward is enabled on the phone. Use the Configuration Utility page to set up more complicated call forward functions, for example, when your line is busy.</p> <p>For more information, see Call Forward Settings, on page 15 or Selective Call Forward Settings, on page 15 and Set Up Phone Features with Phone Adapter Configuration Utility, on page 14.</p>

Feature	Description
Speed dial.	You assign phone numbers to a line so that you can quickly call that person. For more information, see Speed Dial Settings, on page 16 and Set Up Phone Features with Phone Adapter Configuration Utility, on page 14
Supplementary services.	Configure such features as Call waiting, Do not disturb, or Called ID. For more information, see Supplementary Service Settings, on page 17 and Set Up Phone Features with Phone Adapter Configuration Utility, on page 14
Distinctive ring	You can assign a specific ring to a phone number or line. For more information, see Distinctive Ring Settings, on page 18 and Set Up Phone Features with Phone Adapter Configuration Utility, on page 14 .
Ring setting	You can assign a specific ring to a certain situation such as when a call is on hold or during a call back. For more information, see Ring Settings, on page 18 and Set Up Phone Features with Phone Adapter Configuration Utility, on page 14 .

Set Up Phone Features with Phone Adapter Configuration Utility

Use the Phone Adapter Configuration Utility page to set up a few basic features such as Speed dial, Call forward or Do not disturb.

Before you begin

Before you set up a feature, you should review the corresponding settings page.

Procedure

-
- Step 1** Sign into Phone Adapter Configuration Utility as an user.
 - Step 2** Select **Voice > User**
 - Step 3** Navigate to the feature pane and set the fields.
 - Step 4** Click **Save**.
-

Call Forward Settings

You can forward calls from any line on your phone to another phone number. But call forward is phone-line specific. If a call reaches you on a line where call forwarding is not enabled, the call rings as usual.

There are two ways of forwarding your calls:

- Forward all calls
- Forward calls in special situations, such as when the phone is busy or there is no answer.

Call forward is set up from the Voice tab of the Configuration Utility page. Use the information in the following table to guide you. Once you have entered your settings, click **Save** to retain your revisions.

When a call is forwarded, you hear a short ring before the call is forwarded to the new number.

The following table describes the Call Forward settings that you configure from the Voice tab of the Configuration Utility page.

Table 5: Call Forward Settings

Field Name	Description	Usage Guidelines
Cfwd All Dest	Call Forward All Destination. Default setting: blank	Use when you want to forward all of your incoming calls to another phone number. Enter the number that will receive the forwarded call.
Cfwd No Ans Dest	Call Forward No Answer Destination. Default setting: blank	Use with Cfwd All Dest when you want your calls forwarded to a second person, if your first choice does not answer.
Cfwd Busy Dest	Call Forward Busy Destination. Default setting: blank	Use with Cfwd All Dest when you want your calls forwarded to a second person, if your first choice is on another call.
Cfwd No Ans Delay	Call Forward No Answer Delay. Default setting: 20	The delay in seconds before Call Forward No Answer triggers.

Selective Call Forward Settings

You can have a list of up to 8 phone numbers that are forwarded whenever they call you. When someone calls from one of these numbers, you hear a ring and the call is forwarded to the new number.

When entering Call Forward Selective Caller setting, you can use ? to match any single digit or * to match a range of digits. For example:

- 1408*—a call is forwarded to the corresponding destination if the phone number starts with 1408

- 1512???1234—a call is forwarded to the corresponding destination if the phone number is an 11-digit number starting with 1512 and ending with 1234

You can also forward the last call that you received, or block the last call.

Selective call forward is set up from the Voice tab of the Configuration Utility page. Use the information in the following table to guide you. Once you have entered your settings, click **Save** to retain your revisions.

The following table describes the Call Forward settings that you configure from the Voice tab of the Configuration Utility page.

Table 6: Selective Call Forward Settings

Field Name	Description	Usage Guidelines
Cfwd Sel1-8 Caller	Call Forward Selective Caller Default setting: blank	Enter the phone number that you want redirected. When a phone number matches the entry, the call is forwarded to the corresponding Cfwd Selective Destination.
Cfwd Sel1-8 Dest	Call Forward Selective Destination Default setting: blank	Enter the phone number that will receive the forwarded call.
Cfwd Last Caller	Call Forward Last Caller Default setting: blank	Enter the last caller's phone number. This caller is actively forwarded to the Cfwd Last Dest using Call Forward Last.
Cfwd Last Dest.	Call Forward Last Destination Default setting: blank	The destination for the Cfwd Last Caller.
Block Last Caller	- Default setting: blank	The number of the last caller; this caller is blocked via the Block Last Caller Service.
Accept Last Caller	- Default setting: blank	The number of the last caller; this caller is accepted via the Accept Last Caller Service.

Speed Dial Settings

You can use specific phone lines to speed-dial people you call often.

Speed dials are set up from the Voice tab of the Configuration Utility page. Use the information in the following table to guide you. Once you have entered your settings, click **Save** to retain your revisions.

The following table describes the Speed Dial settings that you configure from the Voice tab of the Configuration Utility page.

Table 7: Speed Dial Settings

Field Name	Description	Usage Guidelines
Speed Dial 2-9	- Default setting: blank	Enter a phone number that you dial often.

Supplementary Service Settings

In addition to your main call features, the ATA provides support for several supplementary features. All of these services are optional, and may not be available to you if your administrator has disabled them. In some cases, your service provider may support similar features using means other than the ATA.

Supplementary services are set up from the Voice tab of the Configuration Utility page. Use the information in the following table to guide you. Once you have entered your settings, click **Save** to retain your revisions.

The following table describes the Supplementary Service settings that you configure from the Voice tab of the Configuration Utility page.

Table 8: Supplementary Service Settings

Field	Description	Usage Guidelines
CW Setting	Call Waiting. Default setting: Yes	Enable if you want to be notified of an incoming call while on an call.
Block CID	Block Caller ID. Default setting: No	Allows you to block your phone number from phones that have caller identification enabled.
Block ANC	Block Anonymous Calls. Default setting: No	Allows you to block any calls that do not display call information.
DND Setting	Do Not Disturb. Default setting: No	Use Do Not Disturb (DND) to silence your phone and ignore incoming call notifications when you need to avoid distractions.
CID Setting	Caller ID Generation. Default setting: Yes	Enable if you want your Caller identification such as a phone number, name, or other descriptive text appear on the phone display.

Field	Description	Usage Guidelines
CWCID Setting	Call Waiting Caller ID Generation. Default setting: Yes	This feature assigns an ID for a call that is waiting.
Dist Ring	Distinctive Ring. Default setting: Yes	Enable this feature if you plan to configure different numbers to the same phone and want to give different ringtone for each of the numbers.
Message Waiting	- Default setting: no	Enable if you want to be notified of voicemail messages.
CONFCID Setting	Default setting: Yes	-

Distinctive Ring Settings

You can customize how your phone indicates an incoming call by selecting different ringtones. But this feature requires a specific type of computer code called a script. Contact your administrator to have this feature enabled.

Ring Settings

You can customize your ring tones to best suit your needs. For example, you can have one ringtone for your incoming calls, and another ring for your callback notifications.

Ring settings are set up from the Voice tab of the Configuration Utility page. Use the information in the following table to guide you. Once you have entered your settings, click **Save** to retain your revisions.

The following table describes the Ring settings that you configure from the Voice tab of the Configuration Utility page.

Table 9: Ring Settings

Field Name	Description	Usage Guidelines
Default Ring	- Default setting: 1	Allows you to select from one of 8 different ringtones for your incoming calls.
Default CWT	- Default setting: 1	Allows you to select from one of 8 different ringtones for call waiting.
Hold Reminder Ring	- Default setting: 8	Allows you to select from one of 8 different ringtones or none for calls on hold.

Field Name	Description	Usage Guidelines
Call Back Ring	- Default setting: 7	Allows you to select from one of 8 different ringtones for call back notifications
Cfwd Ring Splash Len	- Default setting: 0	Enter the length of the ring when a call is forwarded, from 0 – 10 seconds.
Cblk Ring Splash Len	- Default setting: 0	Enter the length of the ring for the call back notifications, from 0 – 10 seconds.
VMWI Ring Splash Len:	- Default setting: 0	Enter the length of the ring for your voicemail notifications, from 0 – 10 seconds.

Log

The ATA allows you to record incoming, outgoing, and DHCP lists for various events that occur on your network. The Incoming Log displays a temporary list of the source IP addresses and destination port numbers for the incoming Internet traffic. The Outgoing Log displays a temporary list of the local IP addresses, destination URLs/IP addresses, and service/port numbers for the outgoing Internet traffic.

Debug Log Module

Use the **Administration > Log > Debug Log Module** page to enable and configure logging.

- As a best practice, we recommend that you enable logging only when needed, and disable logging when you finish the investigation. Logging consumes resources and can impact system performance.
- In this page, you can select the modules which you want to see debug messages in all severity levels.

Debug Log Setting

If Debug Log Server is enabled on the **Administration > Log > Debug Log Server** page, the ATA will send the debug messages to one server.

Enter the settings as described below. After making changes, click **Submit** to save your settings, or click **Cancel** to redisplay the page with the saved settings.

Table 10: Debug Log Setting

Field	Description
Debug Log Size	Enter the maximum size of the log file in kilobytes. Valid values are from 128 to 1024.

Field	Description
IPv4 Address	Enter the IPv4 address of the debug log server where the messages will be sent.
IPv6 Address	Enter the IPv6 address of the debug log server where the messages will be sent.
Port	Enter the port to use on the server. Valid values are from 1 to 65535.

Debug Log Viewer

If logging is enabled on the **Administration > Log > Debug Log Viewer** page, you can use the Log Viewer page view the logs online and to download the system log file to your computer. You can limit the contents of the log by choosing the types of entries to include and by specifying keywords.

For information about enabling and configuring logging, see [Debug Log Module, on page 19](#).

Table 11: Debug Log Settings

Field	Description
Download Log	Click this button to download the contents of the log as a file on your computer. In the dialog box, you can open the file or save it. The file can be opened in a text editor such as Notepad.
Clear Log	Click this button to remove all entries from the log.
Filter	Enter a keyword to filter the log entries that appear in the viewer. The page will display only the entries that include the keyword.

Event Log Setting

Use the **Administration > Log > Event Log Setting** page to collect required event logs. Event log messages are sent via SYSLOG protocol using UDP transport type.

Use the Event Log Setting when troubleshooting. Four event categories are defined:

- DEV—Device information. A message is sent once device boot-up and network connectivity are ready.
- SYS—System-related information. A message is sent once while device boot-up and network connectivity are ready.
- CFG—Status of provision and configuration file change. A message is sent every time the provision service restarts due to configuration or network status change.
- REG—Registration status for each line. A message is sent every time registration status changes.

Enter the settings as described below. After making changes, click **Submit** to save your settings, or click **Cancel** to redisplay the page with the saved settings.

Table 12: Event Log Settings

Field	Description
Address	Set the Event log server address.
Port	Set the Event log server port. Default value: 514
Flag	Set the Event log flag, it's a bitwise value. Setting list is as below: <ul style="list-style-type: none"> • <Dev>: 1 (0x01) • <SYS>: 2 (0x01<<1) • <CFG>: 4 (0x01<<2) • <REG>: 8 (0x01<<3) Default value: 15 (All events)

PRT Viewer

Use the **Administration > Log > PRT Viewer** to generate and download Problem Report Tools (PRT) files.

To generate a problem report remotely, see *Generate a Problem Report Remotely*.

After making your changes, click **Submit** to save your settings, or click **Cancel** to redisplay the page with the saved settings.

Table 13: Problem Report Tool Settings

Field	Description
PRT Upload URL	Set the PRT log upload URL
PRT Upload Method	Set the PRT log upload method, POST or PUT . Default: POST
PRT Max Timer	Set the PRT max timer, valid range is 15-1440 minutes Disabled: 0 Default: 0
Problem Report Tools Logs	List the PRT file which is generated by user on ATA.
Generate PRT	Click this button to generate and download the contents of the PRT as a file on your computer. In the dialog box, you can open the file or save it.

Generate a Problem Report Remotely

You can submit a problem report remotely by using the Phone Adapter Configuration Utility.

Before you begin

ATA registers successfully.

Procedure

-
- Step 1** Sign into Phone Adapter Configuration Utility.
- Step 2** Select **Administration > Log > PRT Viewer**.
- Step 3** Configure the **PRT Upload URL** parameter to specify the server to which you want to send the problem report. For example: `http://10.74.133.94:9090`.
- For more information about the PRT related parameters, see [PRT Viewer, on page 21](#).
- Step 4** Click **Submit**.
-

PCM Viewer

Use the **Administration > Log > PCM Viewer** to download and view PCM.

The ATA allows you to capture the PCM log file while a user offhook to start a call.

After making your changes, click **Submit** to save your settings, or click **Cancel** to redisplay the page with the saved settings.

Table 14: Log Viewer Settings

Field	Description
PCM Capture Enable	Enable or disable capture PCM.
Duration	Enter the PCM capture duration in seconds. The valid range is 20 to 300.
PCM File List	List the PCM file which is captured by user. Click Refresh to refresh the PCM Memory Dump File. Click Download to download the dump file on your computer.

CSS Dump

Use the **Administration > Log > CSS Dump** page to set and download CSS dump file.

Table 15: CSS Dump Settings

Field	Description
Auto Crash Dump	Set whether the ATA creates a crash dump file automatically when it occurs an error. Click Enabled to enable the feature, click Disabled to disable it. Default setting: Disabled
Manual Trigger Key(**##)	Set whether the user can manually trigger the creation of the CSS dump by pressing **## on the phone keypad. Click Enabled to enable the feature, click Disabled to disable it. Default setting: Disabled
CSS Dump List	List the CSS file which is captured by user. Click Refresh to refresh the CSS Memory Dump File. Click Download to download the dump file on your computer.

Crash Dump

Use the **Administration > Log > Crash Dump** page to set and download crash dump file.

Table 16: CSS Dump Settings

Field	Description
Runtime log to flash	Set whether the runtime log can be stored in the flash memory. Click Enabled to enable the feature, click Disabled to disable it. Default setting: Disabled
Crash Dump File	Display the captured crash dump file. Click the file name to download it on your computer. Click Refresh to refresh the crash dump file.



CHAPTER 4

Calls

- [Make a call from your analog phone, on page 25](#)
- [Redial a Number from Your Analog Phone, on page 25](#)
- [Answer a call on your ATA phone, on page 26](#)
- [Answer call waiting on your ATA phone, on page 26](#)
- [Put a call on hold on your analog phone, on page 26](#)
- [Forward Your Analog Phone Calls to Another Number, on page 27](#)
- [Transfer a Call from Your Analog Phone, on page 27](#)
- [Make a conference call from your analog phone, on page 28](#)
- [Call Features and Star Codes for Analog Phones, on page 28](#)
- [Make an Emergency Call from Your Analog Phone, on page 29](#)
- [Make a Secure Call, on page 29](#)

Make a call from your analog phone

Your analog phone works just like a Cisco IP phone.

Procedure

- Step 1** Pick up the handset and check for a dial tone.
 - Step 2** (Optional) Dial the digits for an outside line and wait for a dial tone.
 - Step 3** Dial the phone number.
-

Redial a Number from Your Analog Phone

Procedure

- Step 1** Pick up the handset and check for a dial tone.

Step 2 Dial *07.

Answer a call on your ATA phone

Your analogue phone (ATA) works just like a Cisco IP phone.

Procedure

When your analog phone rings, pick up the handset to answer the call.

Answer call waiting on your ATA phone

When you're on an active call, you know that a call is waiting when you hear a single beep.

Procedure

Step 1 Perform a hook flash to speak with another caller who is calling you. You connect to the second caller and put the first caller on hold.

Step 2 (Optional) To speak with the first caller, perform a hook flash again. Subsequent hook flashes toggle you between the two callers. You can't create a conference this way.

Put a call on hold on your analog phone

You can put an active call on hold and then resume the call when you're ready.

Procedure

Step 1 While on an active call, perform a hook flash.

Step 2 To return to the call, either:

- Perform another hook flash.
 - Hang up the handset. Pick up the handset when your phone rings.
-

Forward Your Analog Phone Calls to Another Number

If you're going to be away from your desk, but don't want to miss an important call then forward your calls to another phone.

Procedure

-
- Step 1** To start call forwarding: From your analog phone, press ***72**, enter the number where you want to redirect your calls, and press **#**.
You hear audio indication that call forwarding has started.
- Step 2** To stop call forwarding: From your analog phone, press ***73**.
You hear audio indication that call forwarding has stopped.
-

Transfer a Call from Your Analog Phone

When you transfer a call, you can stay on the original call until the other person answers. You can now talk privately with the other person before you remove yourself from the call.

If you don't want to talk, transfer the call without waiting for the other person to answer. This action is called a blind transfer.

You can also swap between both callers to consult with them individually before you remove yourself from the call.

Procedure

-
- Step 1** From a call that is not on hold, press the flash button.
This puts the existing party on hold and you get a dial tone.
- Step 2** Take one of these actions:
- Enter the other person's phone number.
 - Press ***98** on your phone keypad, then enter the other person's phone number, then press **#**.
- Step 3** (Optional) Wait until you hear ringing or until the other person answers the call.
- Step 4** (Optional) If you wait until the other person answers the call, speak to them to introduce the caller.
- Step 5** Hang up your phone to complete the transfer.
-

Make a conference call from your analog phone

You can talk with several people in a single call.

Procedure

-
- Step 1** While on an active call, perform a hook flash.
This puts the call on hold and you hear dial tone.
- Step 2** Dial a second number and wait until that person answers.
- Step 3** To create the conference, perform a hook flash.
You are now in a conference with both persons.
-

Call Features and Star Codes for Analog Phones

You can use star codes to quickly access many of your call features. An example of a star code is *69 or *78.



Note Star codes are customized to your individual needs by your network administrator. Contact the person responsible for maintaining your network for more information.

Table 17: Call Features and Star Codes

Feature	Description	Turn On	Turn Off
Call forward all	Forward all your calls to another phone	*72	*73
Call return	Call the last caller	*69	
Call back	Start a callback when the last outbound call is not busy	*66	*86
Do not disturb	Silence your phone and ignore all incoming notifications	*78	*79
Redial a number	Redial the previous number you called	*07	
Blind Transfer a call	Transfer a call to another phone without waiting for the other person to answer	*98	

Feature	Description	Turn On	Turn Off
Secure all calls	Make all outbound calls secure	*16	*17
Secure one call	Make the next outgoing call secure (it's redundant if all outgoing calls are set to be secure)	*18	*19

Make an Emergency Call from Your Analog Phone

Use your analog phone to make an emergency call, similar to any other call. When you dial the emergency number, your emergency services get your phone number and location so that they can assist you.



Note If your call disconnects, the emergency services can call you back.

Before you begin

Your analog phone (with the ATA) must be set up to obtain your physical location. Emergency services personnel need your location to find you when you make an emergency call.

Procedure

-
- Step 1** Pick up the handset and check for a dial tone.
 - Step 2** Dial the emergency number.
-

Make a Secure Call

By default, your administrator or service provider enables outgoing calls on your phone for security purposes. If the feature is not enabled and you want to make a secure call, you can do the following:

Procedure

-
- Step 1** Pick up the phone handset.
 - Step 2** Press *18 and then enter the person's phone number.

Once you press *18, you will hear a special tone that indicates the call is switched to the secure mode. In the meantime, press the target number to start the secure call.

Note

During a secure call, you might hear the secure indication tone regularly, depending on your administrator's configuration.

Your outgoing call will be in secure. You cannot force the inbound calls to be secure or not, that depends on whether the caller has security enabled or not. If you want to only accept secure calls on the line, contact your administrator for support.

Step 3 (Optional) To disable the security for an outgoing call, press *19 then enter the person's phone number.



CHAPTER 5

Voice Mail

- [Check your analog phone for new voice messages, on page 31](#)
- [Check Your Voicemail, on page 31](#)

Check your analog phone for new voice messages

You can access your voice messages directly from your phone. But your administrator must set up your voicemail account and set up your phone to access the voicemail system.

Procedure

Pick up the handset and listen for the dial tone.
If you hear a stutter tone, you have new voice messages.

Check Your Voicemail

Before you begin

You can access your voice messages directly from your phone. But your administrator must set up your voicemail account, and set up your phone to access the voicemail system. Each system is slightly different, but your administrator typically provides a phone number used to access your voice messages, and your sign-in information.

Procedure

- Step 1** Dial your voicemail phone number.
 - Step 2** Follow the prompts.
-



CHAPTER 6

Product Safety and Security

- [Safety and Performance Information, on page 33](#)
- [Compliance Statements, on page 34](#)
- [Cisco Product Security Overview, on page 35](#)
- [Important Online Information, on page 35](#)

Safety and Performance Information

Power Outage

Your access to emergency service through the phone requires that the phone receive power. If a power interruption occurs, service or emergency calling service dialing does not function until power is restored. If a power failure or disruption occurs, you may need to reset or reconfigure the equipment before you can use service or emergency calling service dialing.

External Devices

We recommend that you use good-quality external devices that are shielded against unwanted radio frequency (RF) and audio frequency (AF) signals. External devices include headsets, cables, and connectors.

Depending on the quality of these devices and their proximity to other devices, such as mobile phones or two-way radios, some audio noise may still occur. In these cases, we recommend that you take one or more of these actions:

- Move the external device away from the source of the RF or AF signals.
- Route the external device cables away from the source of the RF or AF signals.
- Use shielded cables for the external device, or use cables with a better shield and connector.
- Shorten the length of the external device cable.
- Apply ferrites or other such devices on the cables for the external device.

Cisco cannot guarantee the performance of external devices, cables, and connectors.

**Caution**

In European Union countries, use only external speakers, microphones, and headsets that are fully compliant with the EMC Directive [89/336/EC].

Phone Behavior During Times of Network Congestion

Anything that degrades network performance can affect phone audio and, in some cases, can cause a call to drop. Sources of network degradation can include, but are not limited to, the following activities:

- Administrative tasks, such as an internal port scan or security scan.
- Attacks that occur on your network, such as a Denial of Service attack.

Compliance Statements

FCC Compliance Statements

The Federal Communications Commission requires compliance statements for the following statements.

FCC Part 15.21 Statement

Changes or modifications not expressly approved by the party responsible for compliance could void the user's authority to operate the equipment.

FCC RF Radiation Exposure Statement

This equipment complies with FCC radiation exposure limits set forth for an uncontrolled environment. End users must follow the specific operating instructions for satisfying RF exposure compliance. This transmitter must be at least 20 cm from the user and must not be collocated or operating in conjunction with any other antenna or transmitter.

FCC Receivers and Class B Digital Statement

This product has been tested and complies with the specifications for a Class B digital device, pursuant to Part 15 of the FCC Rules. These limits are designed to provide reasonable protection against harmful interference in a residential installation. This equipment generates, uses, and can radiate radio frequency energy and, if not installed and used according to the instructions, may cause harmful interference to radio communications. However, there is no guarantee that interference will not occur in a particular installation.

If this equipment does cause harmful interference to radio or television reception, which is found by turning the equipment off and on, the user is encouraged to try to correct the interference by one or more of the following measures:

- Reorient or relocate the receiving antenna
- Increase the separation between the equipment or devices
- Connect the equipment to an outlet other than the receiver's
- Consult a dealer or an experienced radio/TV technician for assistance

Compliance Information for Brazil

Cisco Product Security Overview

This product contains cryptographic features and is subject to U.S. and local country laws that govern import, export, transfer, and use. Delivery of Cisco cryptographic products does not imply third-party authority to import, export, distribute, or use encryption. Importers, exporters, distributors, and users are responsible for compliance with U.S. and local country laws. By using this product, you agree to comply with applicable laws and regulations. If you are unable to comply with U.S. and local laws, return this product immediately.

Further information regarding U.S. export regulations can be found at <https://www.bis.gov/ear>.

Important Online Information

End User License Agreement

The End User License Agreement (EULA) is located here: <https://www.cisco.com/go/eula>

Regulatory Compliance and Safety Information

Regulatory Compliance and Safety Information (RCSI) is located here:

https://www.cisco.com/c/dam/en/us/td/docs/voice_ip_comm/cata/19x/RCSI/RCSI-0342-book.pdf

