



# SUPERBLADE SERVER

## SBA-4119S-C2N

## SBA-4119S-T2N



USER'S MANUAL

Revision 1.0a

The information in this User's Manual has been carefully reviewed and is believed to be accurate. The vendor assumes no responsibility for any inaccuracies that may be contained in this document, and makes no commitment to update or to keep current the information in this manual, or to notify any person or organization of the updates. Please Note: For the most up-to-date version of this manual, please see our website at [www.supermicro.com](http://www.supermicro.com).

Super Micro Computer, Inc. ("Supermicro") reserves the right to make changes to the product described in this manual at any time and without notice. This product, including software and documentation, is the property of Supermicro and/or its licensors, and is supplied only under a license. Any use or reproduction of this product is not allowed, except as expressly permitted by the terms of said license.

IN NO EVENT WILL Super Micro Computer, Inc. BE LIABLE FOR DIRECT, INDIRECT, SPECIAL, INCIDENTAL, SPECULATIVE OR CONSEQUENTIAL DAMAGES ARISING FROM THE USE OR INABILITY TO USE THIS PRODUCT OR DOCUMENTATION, EVEN IF ADVISED OF THE POSSIBILITY OF SUCH DAMAGES. IN PARTICULAR, SUPER MICRO COMPUTER, INC. SHALL NOT HAVE LIABILITY FOR ANY HARDWARE, SOFTWARE, OR DATA STORED OR USED WITH THE PRODUCT, INCLUDING THE COSTS OF REPAIRING, REPLACING, INTEGRATING, INSTALLING OR RECOVERING SUCH HARDWARE, SOFTWARE, OR DATA.

Any disputes arising between manufacturer and customer shall be governed by the laws of Santa Clara County in the State of California, USA. The State of California, County of Santa Clara shall be the exclusive venue for the resolution of any such disputes. Supermicro's total liability for all claims will not exceed the price paid for the hardware product.

FCC Statement: This equipment has been tested and found to comply with the limits for a Class A digital device pursuant to Part 15 of the FCC Rules. These limits are designed to provide reasonable protection against harmful interference when the equipment is operated in an industrial environment. This equipment generates, uses, and can radiate radio frequency energy and, if not installed and used in accordance with the manufacturer's instruction manual, may cause harmful interference with radio communications. Operation of this equipment in a residential area is likely to cause harmful interference, in which case you will be required to correct the interference at your own expense.

California Best Management Practices Regulations for Perchlorate Materials: This Perchlorate warning applies only to products containing CR (Manganese Dioxide) Lithium coin cells. "Perchlorate Material-special handling may apply. See [www.dtsc.ca.gov/hazardouswaste/perchlorate](http://www.dtsc.ca.gov/hazardouswaste/perchlorate)".



WARNING: This product can expose you to chemicals including lead, known to the State of California to cause cancer and birth defects or other reproductive harm. For more information, go to [www.P65Warnings.ca.gov](http://www.P65Warnings.ca.gov).

The products sold by Supermicro are not intended for and will not be used in life support systems, medical equipment, nuclear facilities or systems, aircraft, aircraft devices, aircraft/emergency communication devices or other critical systems whose failure to perform be reasonably expected to result in significant injury or loss of life or catastrophic property damage. Accordingly, Supermicro disclaims any and all liability, and should buyer use or sell such products for use in such ultra-hazardous applications, it does so entirely at its own risk. Furthermore, buyer agrees to fully indemnify, defend and hold Supermicro harmless for and against any and all claims, demands, actions, litigation, and proceedings of any kind arising out of or related to such ultra-hazardous use or sale.

Manual Revision 1.0a

Release Date: February 21, 2024

mk

Unless you request and receive written permission from Super Micro Computer, Inc., you may not copy any part of this document. Information in this document is subject to change without notice. Other products and companies referred to herein are trademarks or registered trademarks of their respective companies or mark holders.

Copyright © 2022 by Super Micro Computer, Inc.  
All rights reserved.

**Printed in the United States of America**

# Preface

## About this Manual

This manual is written for professional system integrators and PC technicians. It provides information for the installation and use of this blade server. Installation and maintenance should be performed by experienced technicians only.

Please refer to the SBA-4119S-(C/T)2N specifications page on our website for updates on supported memory, processors and operating systems (<http://www.supermicro.com>).

## Notes

For your system to work properly, please follow the links below to download all necessary drivers/utilities and the user's manual for your server.

- Supermicro product manuals: <http://www.supermicro.com/support/manuals/>
- Product drivers and utilities: [www.supermicro.com/wftp/driver/AMD/SP3](http://www.supermicro.com/wftp/driver/AMD/SP3)
- Product safety info: [http://www.supermicro.com/about/policies/safety\\_information.cfm](http://www.supermicro.com/about/policies/safety_information.cfm)

If you have any questions, please contact our support team at:  
[support@supermicro.com](mailto:support@supermicro.com)

This manual may be periodically updated without notice. Please check the Supermicro website for possible updates to the manual revision level.

## Secure Data Deletion

A secure data deletion tool designed to fully erase all data from storage devices can be found on our website: [https://www.supermicro.com/about/policies/disclaimer.cfm?url=/wftp/utility/Lot9\\_Secure\\_Data\\_Deletion\\_Utility/](https://www.supermicro.com/about/policies/disclaimer.cfm?url=/wftp/utility/Lot9_Secure_Data_Deletion_Utility/)

## Warnings

Special attention should be given to the following symbols used in this manual.



**Warning!** Indicates important information given to prevent equipment/property damage or personal injury.



**Warning!** Indicates high voltage may be encountered when performing a procedure.

# Contents

## **Chapter 1 Introduction**

|                                    |    |
|------------------------------------|----|
| 1.1 Overview.....                  | 7  |
| Eligible Enclosures.....           | 7  |
| 1.2 System Features .....          | 8  |
| 1.3 Control Panel.....             | 9  |
| 1.4 Front View .....               | 10 |
| 1.5 Components .....               | 11 |
| 1.6 System Block Diagrams .....    | 13 |
| 1.7 Motherboard Block Diagram..... | 15 |

## **Chapter 2 Installation and Setup**

|   |    |
|---|----|
| 2.1 Unpacking the System .....                        | 16 |
| 2.2 Installing or Removing the Blade Unit.....        | 17 |
| Installing a Blade Unit into the Enclosure.....       | 17 |
| Removing a Blade Unit from the Enclosure .....        | 18 |
| Removing or Replacing the Blade Cover .....           | 18 |
| 2.3 Powering Up or Down.....                          | 19 |
| Powering Up a Blade Unit.....                         | 19 |
| Powering Down a Blade Unit.....                       | 19 |
| 2.4 Installing the Processor and Heatsink .....       | 20 |
| 2.5 Memory .....                                      | 28 |
| Memory Support .....                                  | 28 |
| DIMM Module Population.....                           | 28 |
| Installing Memory .....                               | 30 |
| 2.6 Storage Drives.....                               | 31 |
| Drive Carrier Indicators .....                        | 31 |
| Hot-Swap for NVMe Drives.....                         | 34 |
| Checking the Temperature of an NVMe Drive .....       | 35 |
| M.2 Solid State Drives .....                          | 36 |
| 2.7 Installing the Mezzanine Card.....                | 38 |
| 2.8 Driver Installation.....                          | 39 |
| 2.9 Installing the Operating System.....              | 40 |
| Linux Installation with Two Storage Drives—Note ..... | 40 |
| 2.10 Configuring RAID .....                           | 40 |

---

---

**Chapter 3 Management and Maintenance**

|   |    |
|---|----|
| 3.1 Management Software .....                 | 41 |
| BMC .....                                     | 41 |
| BMC ADMIN User Password.....                  | 41 |
| 3.2 SuperDoctor® 5.....                       | 43 |
| 3.3 Motherboard Battery.....                  | 44 |
| 3.4 System Cooling .....                      | 45 |
| Installing the Air Shrouds .....              | 45 |
| Checking the Server Air Flow .....            | 46 |
| Overheating.....                              | 46 |
| 3.5 Where to Get Replacement Components ..... | 47 |
| 3.6 Returning Merchandise for Service.....    | 47 |

**Chapter 4 Motherboard Connections**

|                                  |    |
|----------------------------------|----|
| 4.1 Motherboard Layout .....     | 49 |
| Quick Reference .....            | 50 |
| 4.2 Headers and Connectors ..... | 51 |
| 4.3 Jumpers.....                 | 52 |
| 4.4 LED Indicators.....          | 54 |

**Chapter 5 UEFI BIOS**

|                                  |    |
|----------------------------------|----|
| 5.1 Introduction.....            | 55 |
| Starting BIOS Setup Utility..... | 55 |
| 5.2 Main Setup .....             | 55 |
| 5.3 Tab Pages .....              | 57 |

**Appendix A BIOS POST Codes****Appendix B Standardized Warning Statements for AC Systems****Appendix C Specifications and Compliance**

## Contacting Supermicro

### Headquarters

Address: Super Micro Computer, Inc.  
980 Rock Ave.  
San Jose, CA 95131 U.S.A.

Tel: +1 (408) 503-8000

Fax: +1 (408) 503-8008

Email: [marketing@supermicro.com](mailto:marketing@supermicro.com) (General Information)  
[support@supermicro.com](mailto:support@supermicro.com) (Technical Support)

Website: [www.supermicro.com](http://www.supermicro.com)

### Europe

Address: Super Micro Computer B.V.  
Het Sterrenbeeld 28, 5215 ML  
's-Hertogenbosch, The Netherlands

Tel: +31 (0) 73-6400390

Fax: +31 (0) 73-6416525

Email: [sales@supermicro.nl](mailto:sales@supermicro.nl) (General Information)  
[support@supermicro.nl](mailto:support@supermicro.nl) (Technical Support)  
[rma@supermicro.nl](mailto:rma@supermicro.nl) (Customer Support)

Website: [www.supermicro.nl](http://www.supermicro.nl)

### Asia-Pacific

Address: Super Micro Computer, Inc.  
3F, No. 150, Jian 1st Rd.  
Zhonghe Dist., New Taipei City 235  
Taiwan (R.O.C)

Tel: +886-(2) 8226-3990

Fax: +886-(2) 8226-3992

Email: [support@supermicro.com.tw](mailto:support@supermicro.com.tw)

Website: [www.supermicro.com.tw](http://www.supermicro.com.tw)

# Chapter 1

## Introduction

### 1.1 Overview

The SBA-4119S-(C/T)2N blade is a compact self-contained server that connects into a pre-cabled enclosure that provides power, cooling, management and networking functions. One enclosure can hold up to twenty blades. Each blade contains one computing node.

In this manual, “blade” or “blade unit” refers to a single blade, and “blade enclosure” is the chassis that houses the blades, power supplies and other modules. “Blade system” refers to the enclosure, blades units, and various management and networking modules.

This chapter provides a brief outline of the functions and features of the SBA-4119S-(C/T)2N blade server. It is based on the BH12SSi-M25 motherboard.

| Models        |                        |                  |
|---------------|------------------------|------------------|
| System        | Storage Type           | Add-on Module    |
| SBA-4119S-T2N | SATA/NVMe hybrid ports | AOM-BPNIO-SNEA-P |
| SBA-4119S-C2N | SAS/NVMe hybrid ports  | AOM-BPNIO-SCEA-P |

In addition, several important parts are listed below.

| Main Parts List   |                  |          |
|---|------------------|----------|
| Description   | Part Number      | Quantity |
| Add-on card, front control I/O                                      | AOM-BPNIO-FPE-P  | 1        |
| Blade chassis   | MCP-680-41006-0N | 1        |
| Air Shroud  | MCP-310-41006-0N | 1        |
| Heatsink, vapor chamber ( <i>optional</i> )                         | SNK-P1043V       | 1        |
| Add-on card, 4 x M.2 NVMe mezzanine card 4x ( <i>optional</i> )     | AOM-B-4M         | 1*       |
| Network add-on card, Infiniband mezzanine ( <i>optional</i> )       | AOC-IBH-X4ES-O   | 1*       |
| Network, add-on card, 2 port 25G mezzanine card ( <i>optional</i> ) | AOC-B25G-X4D     | 1*       |

\*Mutually exclusive; only one mezzanine card can be installed.

### Eligible Enclosures

- SBE-820C-XXX
- SBE-820J-XXX
- SBE-820L-XXX

## 1.2 System Features

The following is an overview of the main features of the SBA-4119S-(C/T)2N blade server.

| <b>System Features</b>  |
|---|
| <b>Motherboard</b>  |
| BH12SSi-M25   |
| <b>CPU</b>  |
| Single AMD EPYC 7002 Series processor (in Socket SP3); For the latest CPU/memory updates, refer to our website at <a href="http://Supermicro.com">Supermicro.com</a>                          |
| <b>Chipset</b>  |
| System on Chip  |
| <b>Memory</b>   |
| Eight slots for up to 2 TB of 3DS RDIMM/LRDIMM), with speeds of up to 3200 MHz; support for Non-Volatile DIMM (NVDIMM)  |
| <b>Storage Drives</b>   |
| Two hot-swap 2.5" U.2 (stack up) hybrid bays for:<br>SBA-4119S-T2N, SATA or NVMe with add-on module<br>SBA-4119S-C2N, SAS or NVMe with add-on module<br>M.2: Up to two PCI-E 4.0 NVMe or SATA |
| <b>BIOS</b>   |
| 128Mb SPI Flash EEPROM with AMI BIOS  |
| <b>LAN Connections</b>  |
| Two 25G onboard   |
| <b>Form Factor</b>  |
| (WxHxD) 1.75 x 6.5 x 23.5 in. (44.5 x 165 x 597 mm)   |

## 1.3 Control Panel

Power switches and status LEDs are located on the control panel on the front of the chassis.

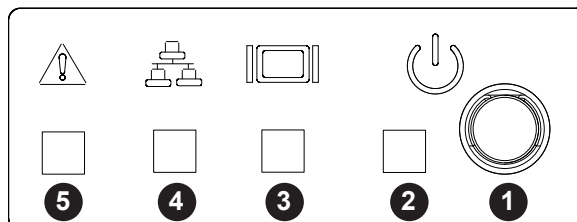

Figure 1-1. Control Panel

| Control Panel Features |                 |                        |  |
|------------------------|-----------------|------------------------|--|
| Item                   | Feature         | State                  | Description  |
| 1                      | Power button    |                        | The main power switch applies or removes primary power from the power supply to the server but maintains standby power.                    |
| 2                      | Power LED       | Green                  | Power on   |
|                        |                 | Amber, flashing        | Before the BMC is ready, blinks until every node is ready  |
|                        |                 | Amber, steady          | Power off  |
| 3                      | KVM/UID LED     | Blue, steady           | Indicates that KVM has been initialized  |
|                        |                 | Blue, flashing slowly  | Unit Identifier indicator (The UID function is activated with a management program.)   |
|                        |                 | Blue, flashing quickly | Firmware revision  |
| 4                      | NIC LED         | Green, flashing        | Indicates traffic (Tx and RX data) on the LAN connection to this blade module  |
|                        |                 | Orange, flashing       | Indicates traffic over the network (when present in the system)  |
| 5                      | System Fail LED | Red                    | Indicates a fatal error. This may be a memory error, a VGA error or any other fatal error that prevents the operating system from booting. |

## 1.4 Front View

The illustration below shows the features on the front of the blade unit.

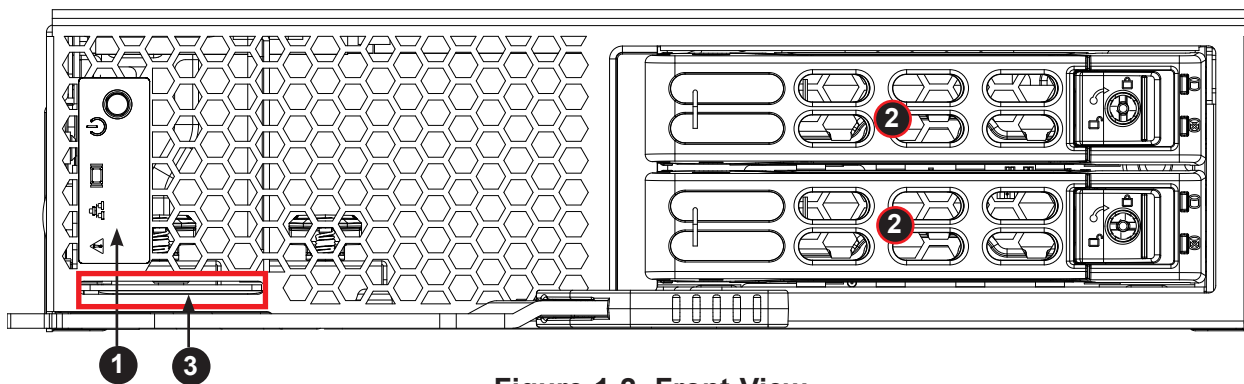

Figure 1-2. Front View

| Chassis Front Features |                   |   |
|------------------------|-------------------|---|
| Item                   | Features          | Description   |
| 1                      | Control Panel     | Power button and status indicators  |
| 2                      | Storage Drives    | Two hot-swap 2.5" drive bays for NVME, SAS, or SATA; the drive carriers display status lights |
| 3                      | Service/Asset Tag | Pull-out identifier (with BMC ADMIN default password sticker)                                 |

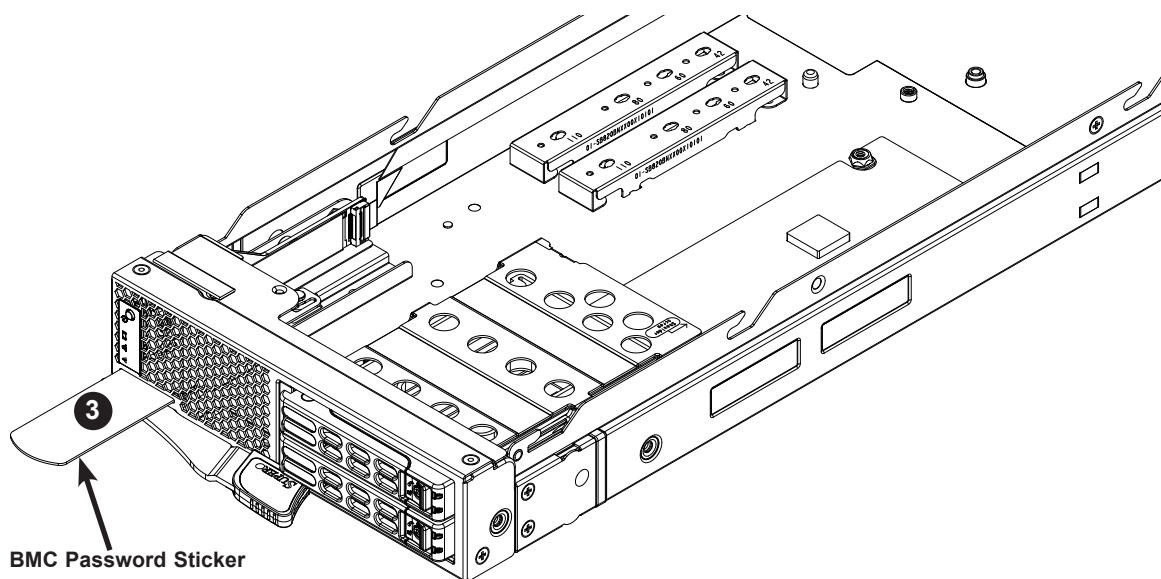

Figure 1-3. Location of the BMC Password Label

# 1.5 Components

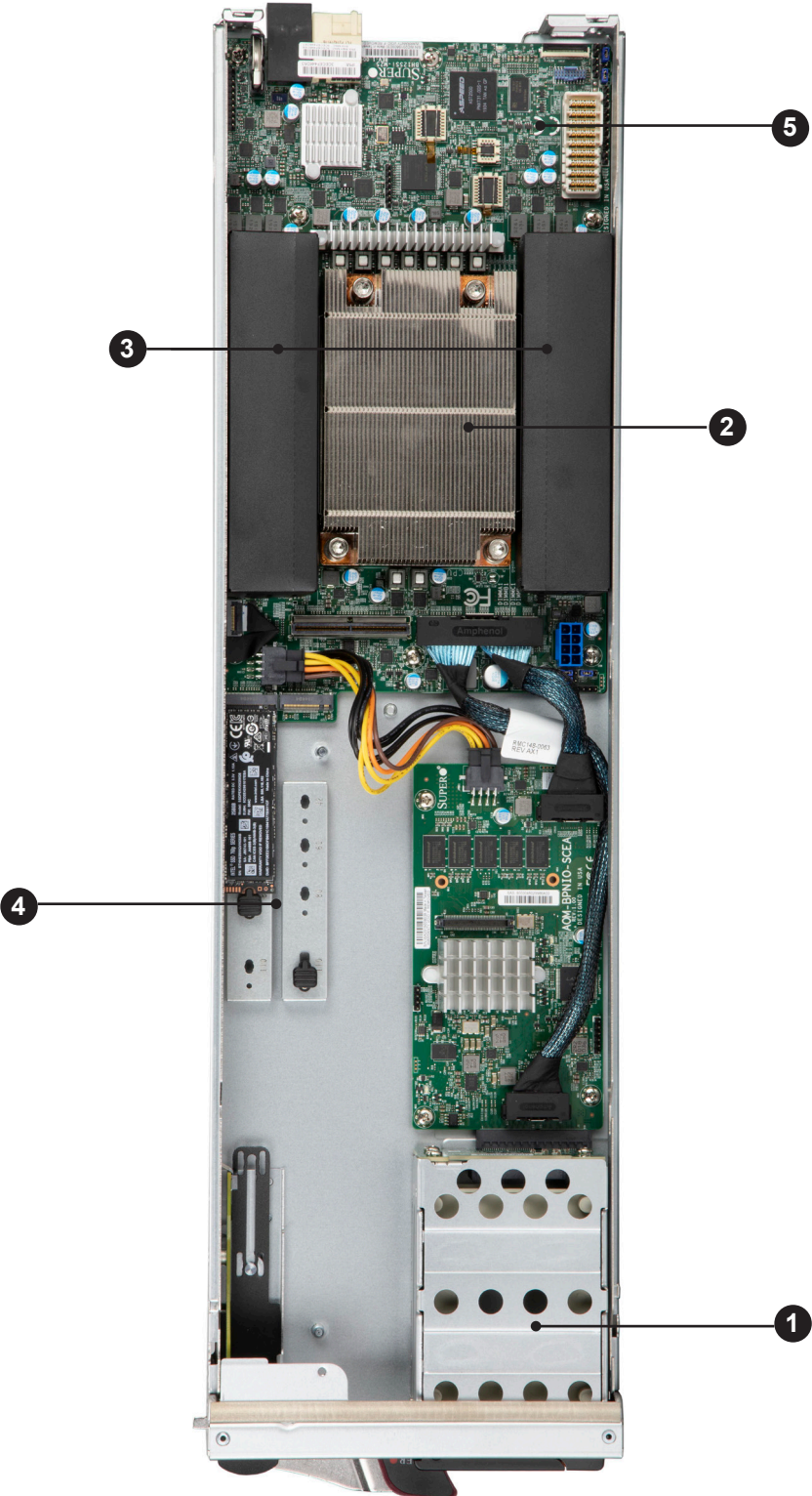

Figure 1-4. Components Labeled (see the next page)

| <b>Blade Components</b> |                |   |
|-------------------------|----------------|---|
| <b>Item</b>             | <b>Feature</b> | <b>Description</b>                        |
| 1                       | Drives         | Two 2.5" storage drives                   |
| 2                       | CPU            | Processor and heatsink                    |
| 3                       | Memory         | DIMM slots (under air shrouds)            |
| 4                       | M.2 Slots      | Slots and standoffs for M.2 storage cards |
| 5                       | Mezzanine      | Add-on card                               |

## 1.6 System Block Diagrams

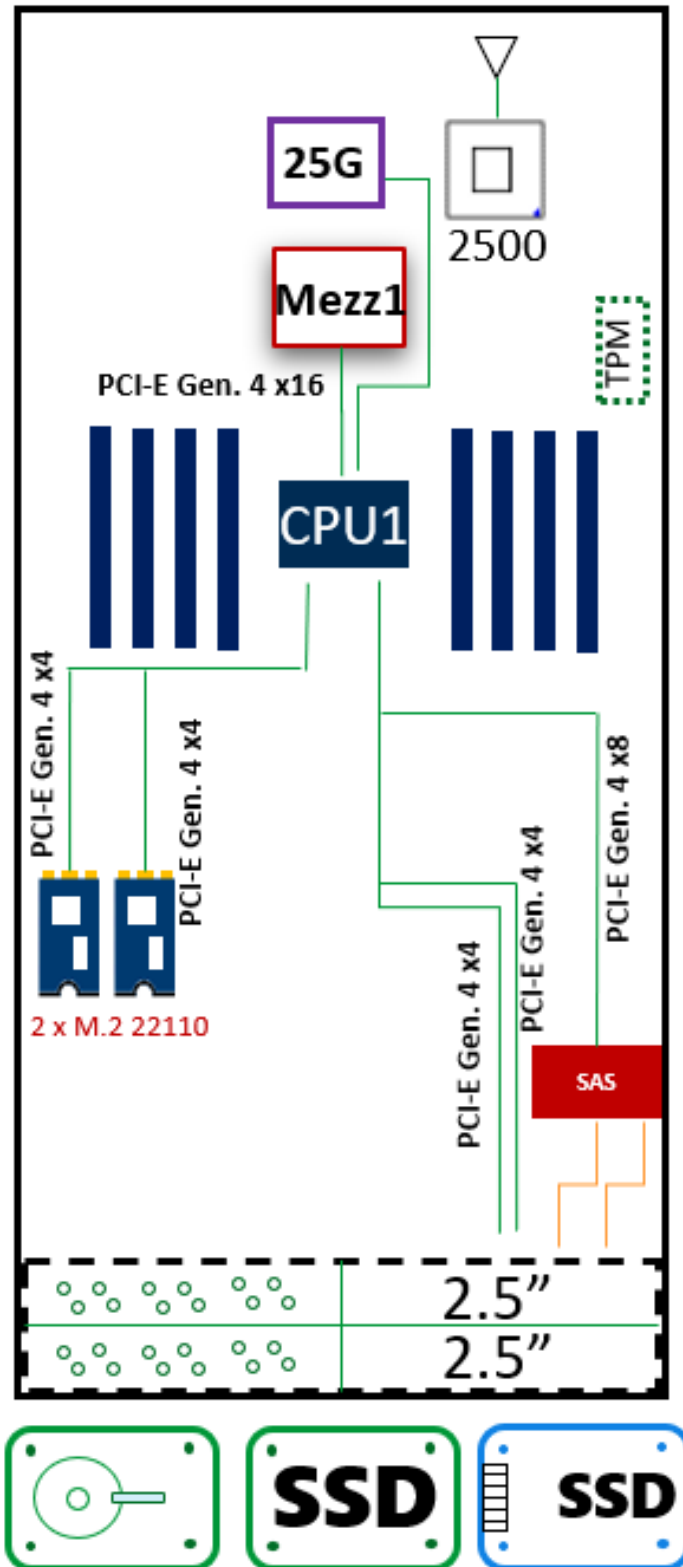

Figure 1-5. System Block Diagram, SBA-4119S-C2N

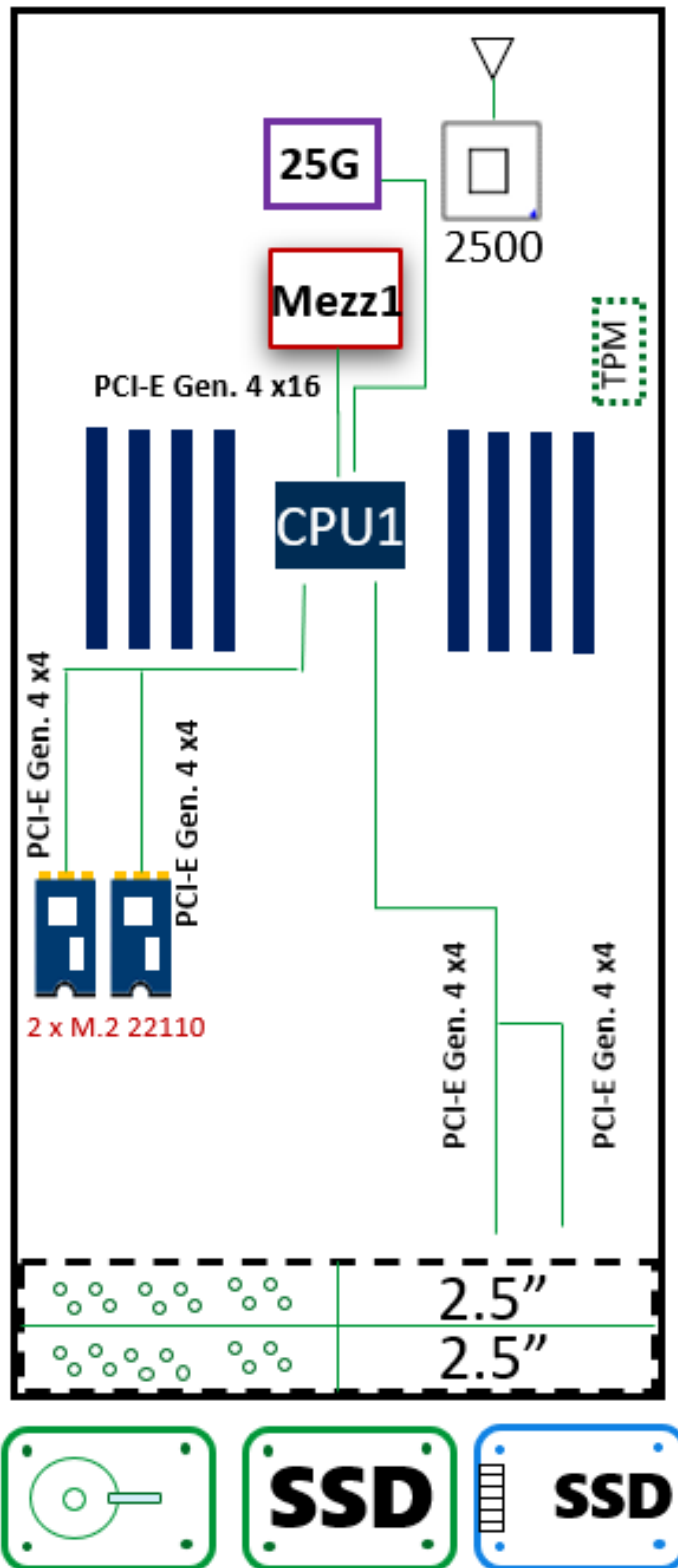

Figure 1-6. System Block Diagram, SBA-4119S-T2N

## 1.7 Motherboard Block Diagram

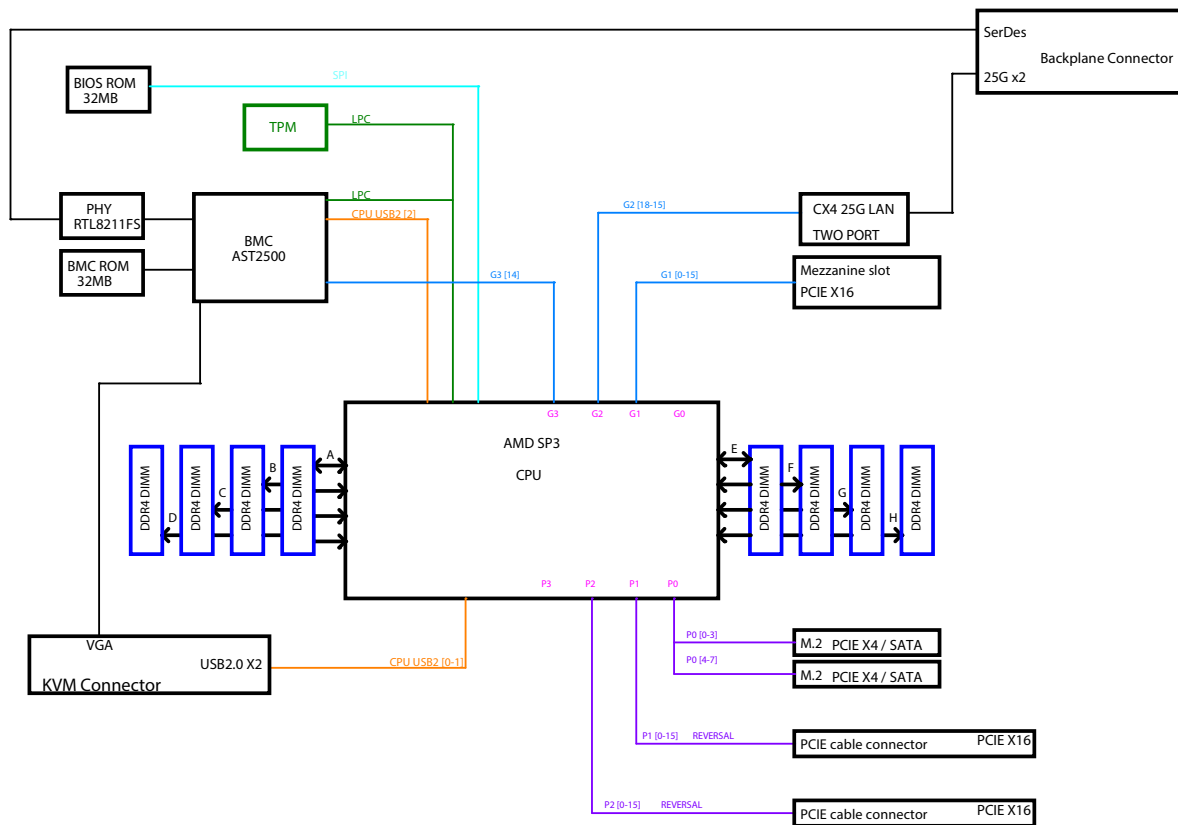

Figure 1-7. Motherboard Block Diagram

## Chapter 2

### Installation and Setup

This chapter provides instructions on installing and replacing main system components. To prevent compatibility issues, only use components that match the specifications or part numbers.

Up to twenty blade modules may be installed into a blade enclosure, depending upon your enclosure and blade. Blade modules with Windows and Linux operating systems may be mixed together in the same blade enclosure.

#### 2.1 Unpacking the System

Inspect the box the system was shipped in and note if it was damaged in any way. If any equipment appears damaged, please file a damage claim with the carrier who delivered it.

Decide on a suitable location for the rack unit that will hold the enclosure. It should be situated in a clean, dust-free area that is well ventilated. Avoid areas where heat, electrical noise and electromagnetic fields are generated. It will also require a grounded AC power outlet nearby. Be sure to read the precautions and considerations noted in Appendix B.

## 2.2 Installing or Removing the Blade Unit

### Installing a Blade Unit into the Enclosure

Make sure the cover of the blade unit is on before insertion.

#### *Installing a Blade Unit into the Enclosure*

1. Pull open the blade locking handle and slowly push the blade into its bay as pictured below.
2. When the blade stops, push the handle into its locked position, making sure the notch in the handle catches the lip of the enclosure.

**Caution:** Insert the blade carefully to avoid damaging the connectors in the enclosure bay.

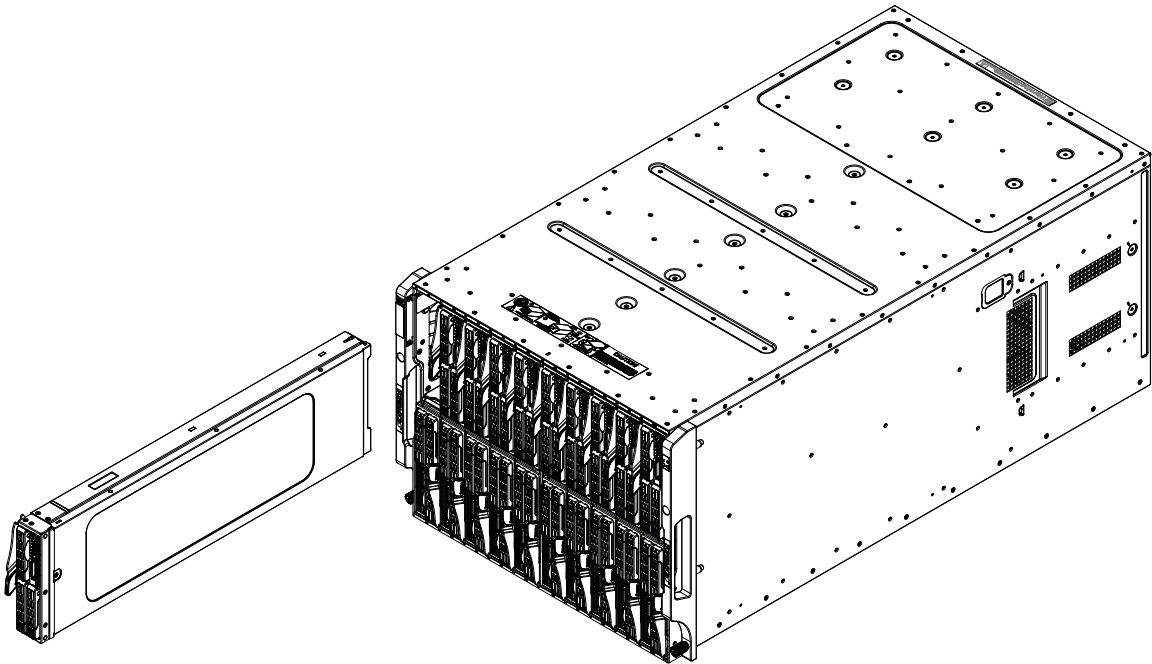

Figure 2-1. Installing the a Blade into the Enclosure

## **Removing a Blade Unit from the Enclosure**

A blade can be removed from the enclosure while other blades continue to operate.

### ***Removing a Blade Unit from the Enclosure***

1. Power down the blade unit.
2. Lift the handle completely and use it to pull the blade unit from the enclosure.

## **Removing or Replacing the Blade Cover**

The blade cover can be removed to access the mainboard and install processors, memory modules, the onboard battery, etc.

- To remove the cover, after removing the blade module from the enclosure, push the cover toward the rear of the blade unit. When it stops, lift the cover off the blade unit.
- To replace the cover, fit the six grooves in the cover into the studs in the sides of the blade, then slide the cover toward the front of the blade to lock it into place.

## 2.3 Powering Up or Down

### Powering Up a Blade Unit

Each blade unit may be powered on and off independently from the rest of the blades installed in the same enclosure. A blade unit may be powered up in two ways:

- Press the power button on the blade unit.
- Use IPMIView or the web-browser based management utility to apply power using either a CMM module, or by the use of the onboard BMC chip in the blade module.

### Powering Down a Blade Unit

A blade unit may be powered down in any of the following ways:

- Press the power button on the blade unit.
- Use IPMIView or the web-browser based management utility to power down; requires Operator or Admin privileges on the CMM.
- Use SMCIPMItool when connected to the CMM to power down; requires Operator or Admin privileges on the CMM.
- Use IPMIview or a browser connected to the onboard BMC chip to power down.
- Use SMCIPMItool to use a Command Line Interface to the onboard BMC chip; requires Operator or Admin privileges.

## 2.4 Installing the Processor and Heatsink

### Cautions:

- When handling the processor (CPU) package, avoid placing direct pressure on the label area of the CPU or CPU socket.
- Improper CPU installation or socket misalignment can cause serious damage to the CPU or motherboard which may result in RMA repairs.
- Take all standard precautions to avoid electrostatic discharge (ESD) which can damage components.

Assemble the processor (CPU) and heatsink together first then install that assembly onto the CPU socket.

### Notes:

- The motherboard should be installed into the chassis first and the processor should be installed into the CPU socket before you install a CPU heatsink.
- If you bought a CPU separately, use a certified multi-directional heatsink only.
- When receiving a motherboard without a processor pre-installed, make sure that the plastic CPU socket cap is in place and none of the socket pins are bent; otherwise, contact your retailer immediately.
- Refer to the [SuperMicro web site](#) for updates on CPU support.

### ***Installing the Processor and Heatsink***

Begin by removing power from the system as described in Section 2.3.

1. Use a Torx T20 driver to loosen the screws holding down Force Frame in the sequence of 3-2-1. The screws are numbered on the Force Frame next to each screw hole. Tighten to 16.1 kgf-cm (14 lbf-in) of torque.

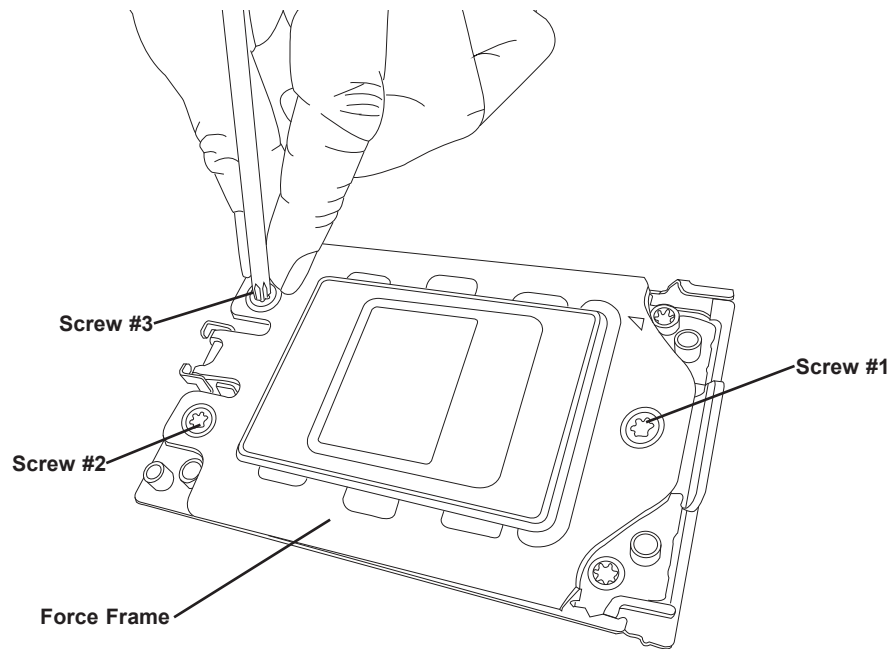

**Figure 2-3. Removing the Processor Force Frame**

2. The spring-loaded Force Frame will raise up after the last screw (#1) is removed. Gently allow it to lift up to its stopping position.

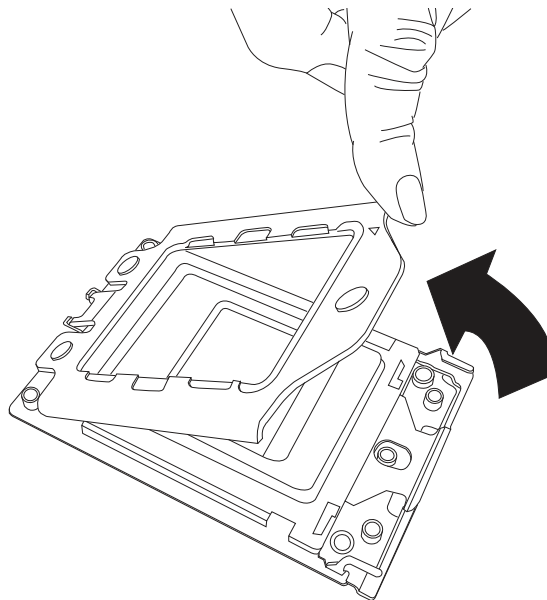

**Figure 2-4. Raising the Force Frame**

3. Lift the Rail Frame up by gripping the lift tabs near the front end of the rail frame. While keeping a secure grip of the Rail Frame, lift it to a position so you can do the next step of removing the External Cap.

**Note:** The Rail Frame is spring loaded, so keep a secure grip on it as you lift it so it does not snap up.

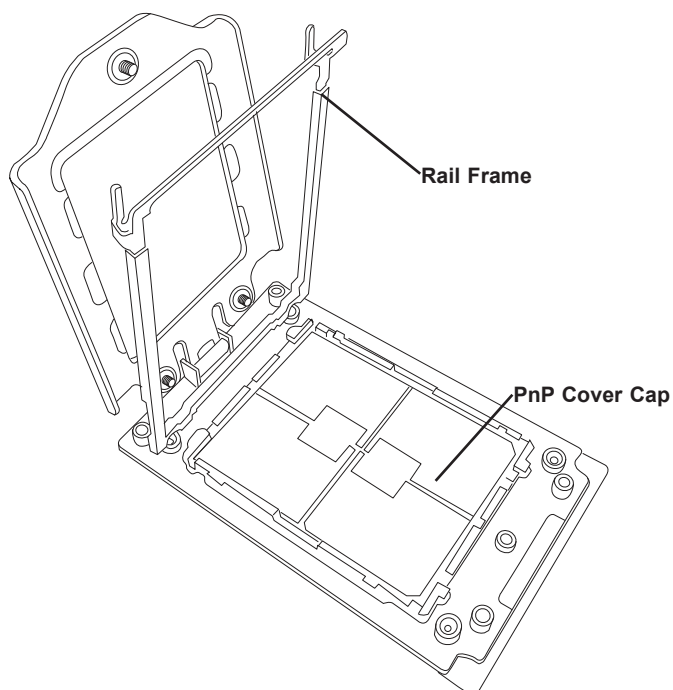

**Figure 2-5. Lifting the Rail Frame**

4. Remove the External Cap from the Rail Frame by pulling it upwards through the rail guides on the Rail Frame.

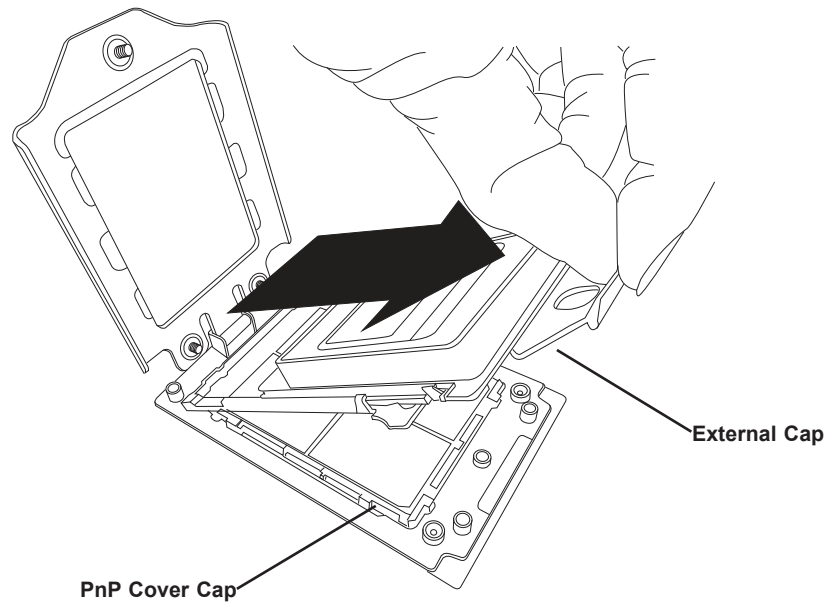

**Figure 2-6. Removing the External Cap**

5. The CPU Package is shipped from the factory with the blue Carrier Frame pre-assembled. Grip the handle of the Carrier Frame/CPU Package assembly from its shipping tray, and while gripping the handle, align the flanges of the Carrier Frame onto the rails of the Rail Frame so its pins will be at the bottom when the Rail Frame is lowered later.
6. Slide the Carrier Frame/CPU Package downwards to the bottom of the Rail Frame. Ensure the flanges are secure on the rails as you lower it downwards.

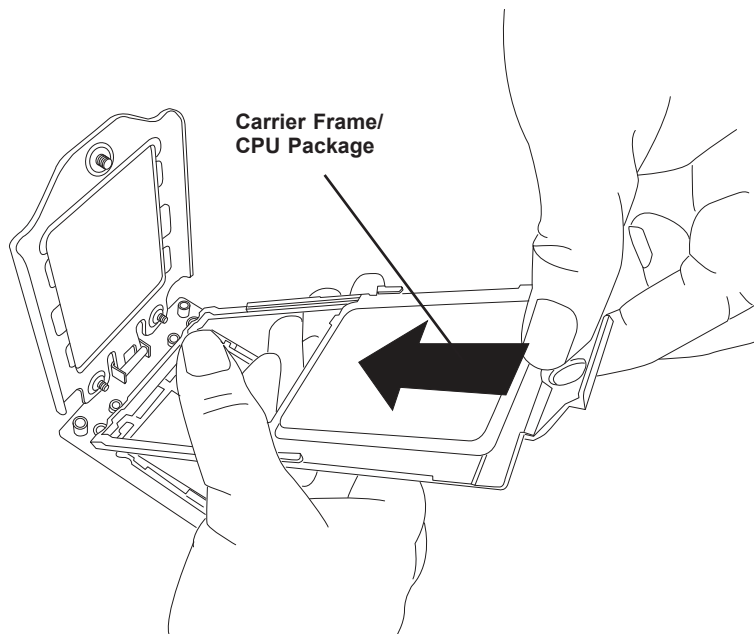

**Figure 2-7. Inserting the Carrier Frame/CPU Package**

**Note:** You can only install the CPU inside the socket in one direction with the handle at the top. Make sure that it is properly inserted into the CPU socket before closing the Rail Frame plate. If it doesn't close properly, do not force it as it may damage your CPU. Instead, open the Rail Frame plate again, and double-check that the CPU is aligned properly.

7. Lift up the Rail Frame till it securely rests in upright position. Then remove the PnP Cover Cap from the CPU socket below. Grip the two lift tabs marked "Remove" at the middle of the cap and pull vertically upwards to remove the PnP Cover Cap.

**Caution:** The exposed socket contacts are extremely vulnerable and can be damaged easily. Do not touch or drop objects onto the contacts and be careful removing the PnP Cover Cap and when placing the Rail Frame over the socket.

8. Gently lower the Rail Frame down onto the socket until the latches on the Rail Frame engage with the Socket housing. and it rests in place. Do not force it into place!
9. Gently lower the Force Frame down onto the Rail Frame and hold it in place until it is seated in the Socket housing. Note that the Force Frame is spring loaded and has to be held in place before it is secured.

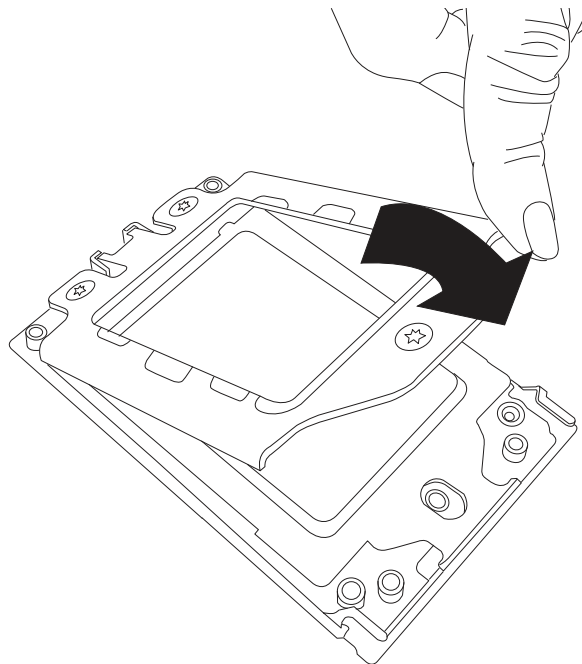

**Figure 2-8. Lowering the Force Frame**

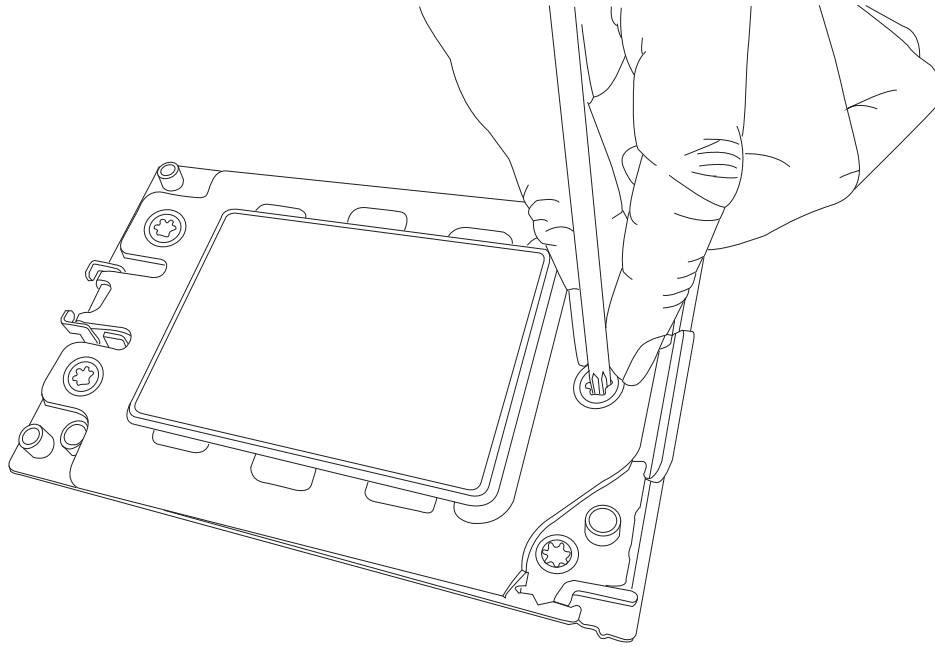

**Figure 2-9. Securing the Force Frame**

10. Replace the screws in the order 1-2-3, tightening to 16.1 kgf-cm (14 lbf-in) of torque. The Force Frame secures both the Rail Frame and CPU Package.

**Caution:** Tightening must be executed in proper 1-2-3 sequence to avoid causing catastrophic damage to the socket or CPU Package.

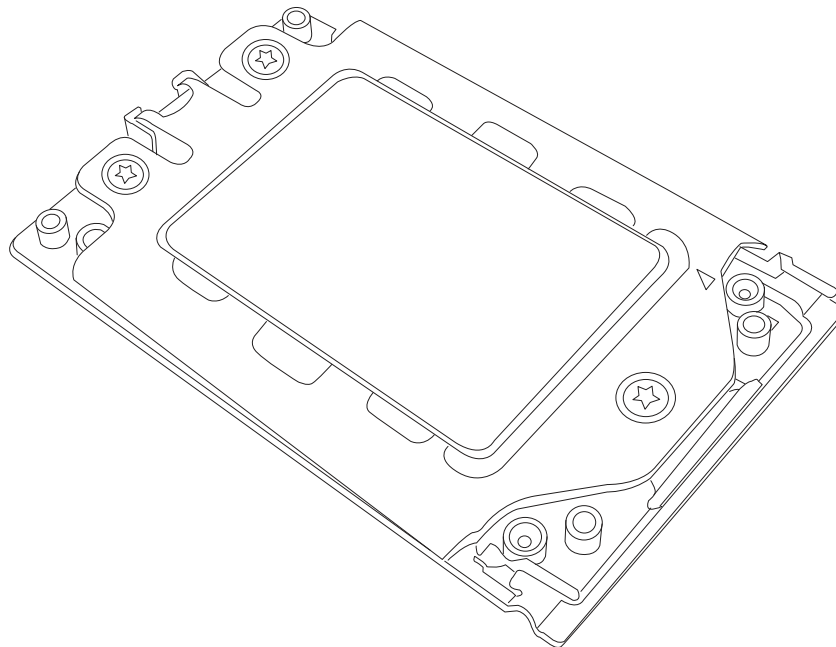

**Figure 2-10. The Force Frame Secured**

11. Lower the heatsink down till it rests securely on CPU Package over the four screw holes on the socket frame.

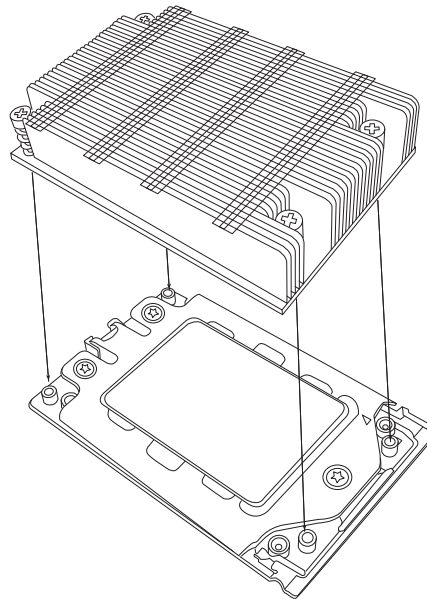

**Figure 2-11. Mounting the Heatsink**

12. Using a Torx T20 driver in a diagonal pattern as below, tighten the four heatsink screws halfway and then tighten them evenly to 16.1 kgf-cm (14.0 lbf-in) of torque.

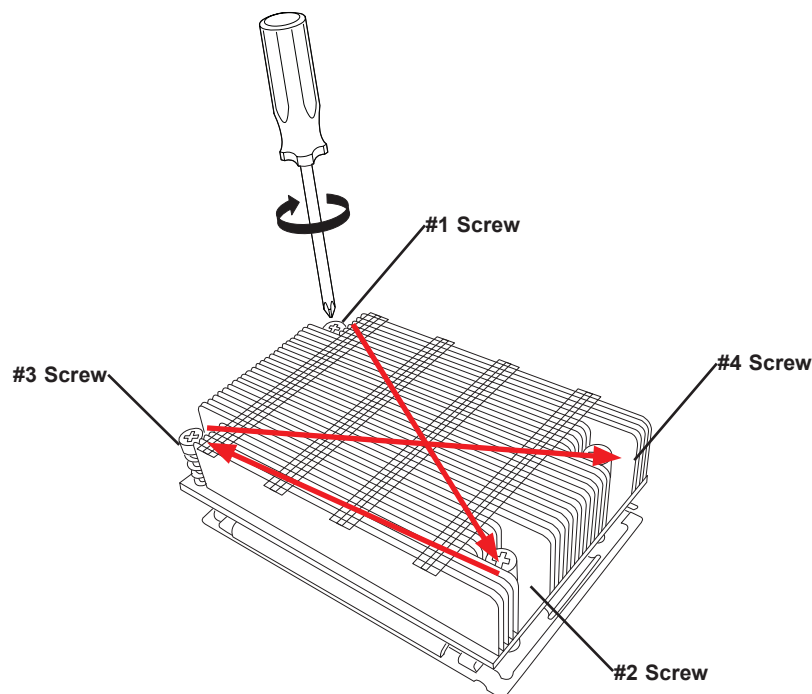

**Figure 2-12. Securing the Heatsink**

The processor and heatsink installation is complete. Repeat this procedure for any remaining CPU sockets on the motherboard.

### ***Removing a Heatsink***

We do not recommend removing the heatsink. If necessary, please follow the instructions below to prevent damage to the CPU or the CPU socket.

**Note:** Wait for the heatsink to cool down before removing it.

1. Unscrew and remove the heatsink screws from the motherboard in the sequence as show in the figure above.
2. Hold and gently pivot the heatsink back and forth to loosen it from the CPU. (Do not use excessive force when dislodging the heatsink!)
3. Once the heatsink is loose, remove it from the CPU.
4. Clean the surface of the CPU and the heatsink to get rid of the old thermal grease. Reapply the proper amount of thermal grease to the surface before you re-install the heatsink.

## 2.5 Memory

### Memory Support

The BH12SSi-M25 supports up to 2TB of 3DS ECC DDR4 3200 MHz speed, RDIMM/LRDIMM/3DS/NVDIMM memory in eight slots. Refer to the table below for additional memory information.

Check the [SuperMicro web site](#) for possible updates to memory support.

| Populating RDIMM/RDIMM 3DS/LRDIMM/LRDIMM 3DS DDR4 Memory Modules |                   |                            |            |            |                         |
|--|-------------------|----------------------------|------------|------------|-------------------------|
| Type   | DIMM Population   | Maximum DIMM Capacity (GB) |            |            | Maximum Frequency (MHz) |
|  |                   | 1 Channel                  | 4 Channels | 8 Channels |                         |
| RDIMM  | 1R                | 32GB                       | 128GB      | 256GB      | 3200                    |
|  | 2R                | 64GB                       | 256GB      | 512GB      | 3200                    |
| LRDIMM   | 4R                | 128GB                      | 512GB      | 1TB        | 3200                    |
|  | 2S4R              | 256GB                      | 1TB        | 2TB        | 3200                    |
| LRDIMM 3DS   | 2S2R<br>(4 Ranks) | 128GB                      | 512GB      | 1TB        | 3200                    |
|  | 2S4R<br>(8 Ranks) | 256GB                      | 1TB        | 2TB        | 3200                    |

### DIMM Module Population

When populating the motherboard with DIMM modules, please keep in mind the following:

- Always use DDR4 DIMM modules of the same type, size and speed.
- All eight memory channels per CPU socket should be populated with each channel having equal capacity. This enables the memory subsystem to operate in eight-way interleaving mode, which should provide the best performance in most cases.
- In most configurations, populating fewer than eight channels is supported, but not recommended.

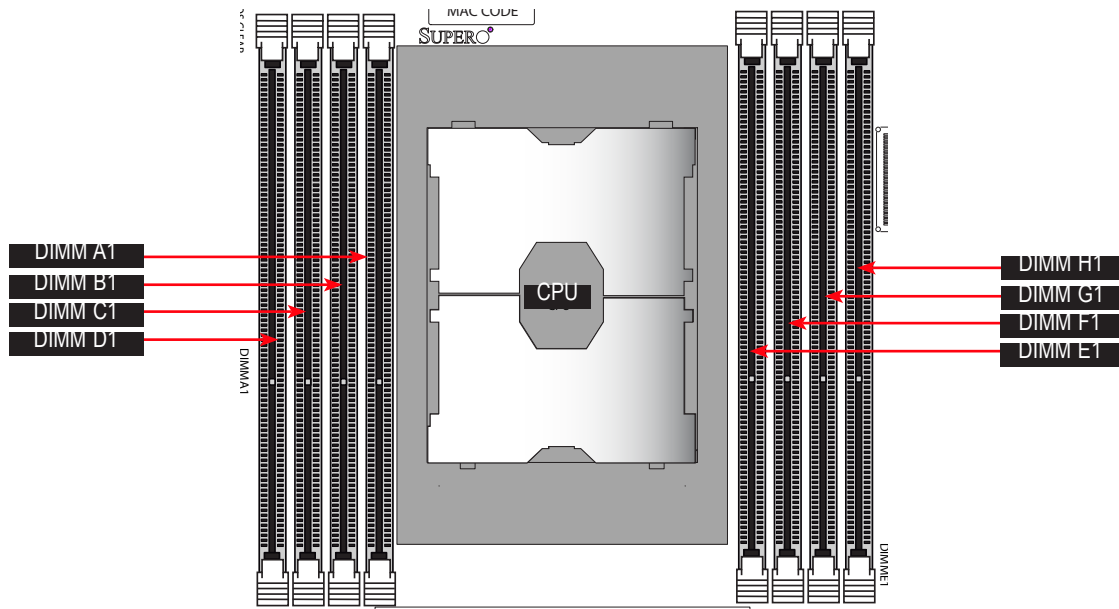

Figure 2-13. DIMM Numbering

| Memory Module Distribution           |    |    |    |    |    |    |    |
|--------------------------------------|----|----|----|----|----|----|----|
| Channel                              |    |    |    |    |    |    |    |
| D1                                   | C1 | B1 | A1 | E1 | F1 | G1 | H1 |
| 1 DIMM (Supported, Not Recommended)  |    |    |    |    |    |    |    |
|                                      | ✓  |    |    |    |    |    |    |
| 2 DIMMs (Supported, Not Recommended) |    |    |    |    |    |    |    |
| ✓                                    | ✓  |    |    |    |    |    |    |
| 4 DIMMs                              |    |    |    |    |    |    |    |
| ✓                                    | ✓  |    |    |    |    | ✓  | ✓  |
| 6 DIMMs                              |    |    |    |    |    |    |    |
| Unbalanced, not recommended          |    |    |    |    |    |    |    |
| 8 DIMMs                              |    |    |    |    |    |    |    |
| ✓                                    | ✓  | ✓  | ✓  | ✓  | ✓  | ✓  | ✓  |

**\*Note:** Most configurations populating fewer than eight channels are supported, but not recommended.

## Installing Memory

### *ESD Precautions*

Electrostatic Discharge (ESD) can damage electronic components including memory modules. To avoid damaging DIMM modules, it is important to handle them carefully. The following measures are generally sufficient.

- Use a grounded wrist strap designed to prevent static discharge.
- Handle the memory module by its edges only.
- Put the memory modules into the antistatic bags when not in use.

### *Installing Memory*

Begin by removing power from the system as described in Section 3.1. Follow the memory population sequence in the table above.

1. Push the release tabs outwards on both ends of the DIMM slot to unlock it.

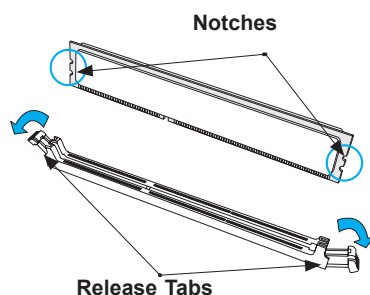

2. Align the key of the DIMM with the receptive point on the memory slot and with your thumbs on both ends of the module, press it straight down into the slot until the module snaps into place.

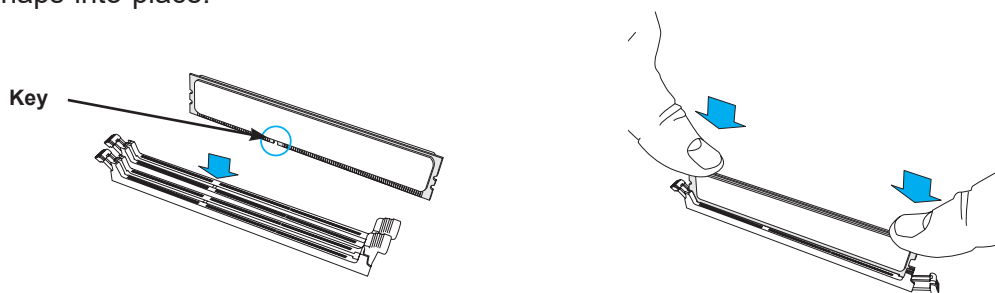

3. Press the release tabs to the locked position to secure the DIMM module into the slot.

**Caution:** Exercise extreme caution when installing or removing memory modules to prevent damage to the DIMMs or slots.

### *Removing Memory*

To remove a DIMM, unlock the release tabs then pull the DIMM from the memory slot.

## 2.6 Storage Drives

The blade has two 2.5" hot-swap storage drive bays. The drives are mounted in drive carriers that simplify their removal from the chassis. These carriers also help promote proper airflow. Even carriers without drives must remain in the chassis for proper airflow.

The blade can be purchased with drives installed or without drives installed.

**Note:** Enterprise level hard disk drives are recommended for use in Supermicro systems. For information on recommended drives, visit the [SuperMicro web site](#).

### Drive Carrier Indicators

Each drive carrier has two LED indicators: an activity indicator and a status indicator. For RAID configurations using a controller, the meaning of the status indicator is described in the table below. For OS RAID or non-RAID configurations, some LED indications are not supported, such as hot spare.

| Drive Carrier LED Indicators |       |   |   |
|------------------------------|-------|---|---|
|                              | Color | Blinking Pattern                              | Behavior for Device   |
| <b>Activity LED</b>          | Blue  | Solid On                                      | SAS/NVMe drive installed  |
|                              | Blue  | Blinking                                      | I/O activity  |
| <b>Status LED</b>            | Red   | Solid On                                      | Failure of drive with RSTe support  |
|                              | Red   | Blinking at 1 Hz                              | Rebuilding drive with RSTe support  |
|                              | Red   | Blinking with two blinks and one stop at 1 Hz | Hot spare for drive with RSTe support<br><i>(not supported in VMD mode)</i>     |
|                              | Red   | On for five seconds, then off                 | Power on for drive with RSTe support  |
|                              | Red   | Blinking at 4 Hz                              | Identify drive with RSTe support  |
|                              | Green | Solid On                                      | Safe to remove NVMe device<br><i>(not supported in VMD mode)</i>                |
|                              | Amber | Blinking at 1 Hz                              | Attention state—do not remove NVMe device<br><i>(not supported in VMD mode)</i> |

### ***Removing a Hot-Swap Drive Carrier from the Chassis***

1. Press the release button on the drive carrier, which will extend the drive carrier handle.
2. Use the drive carrier handle to pull the drive out of the chassis.

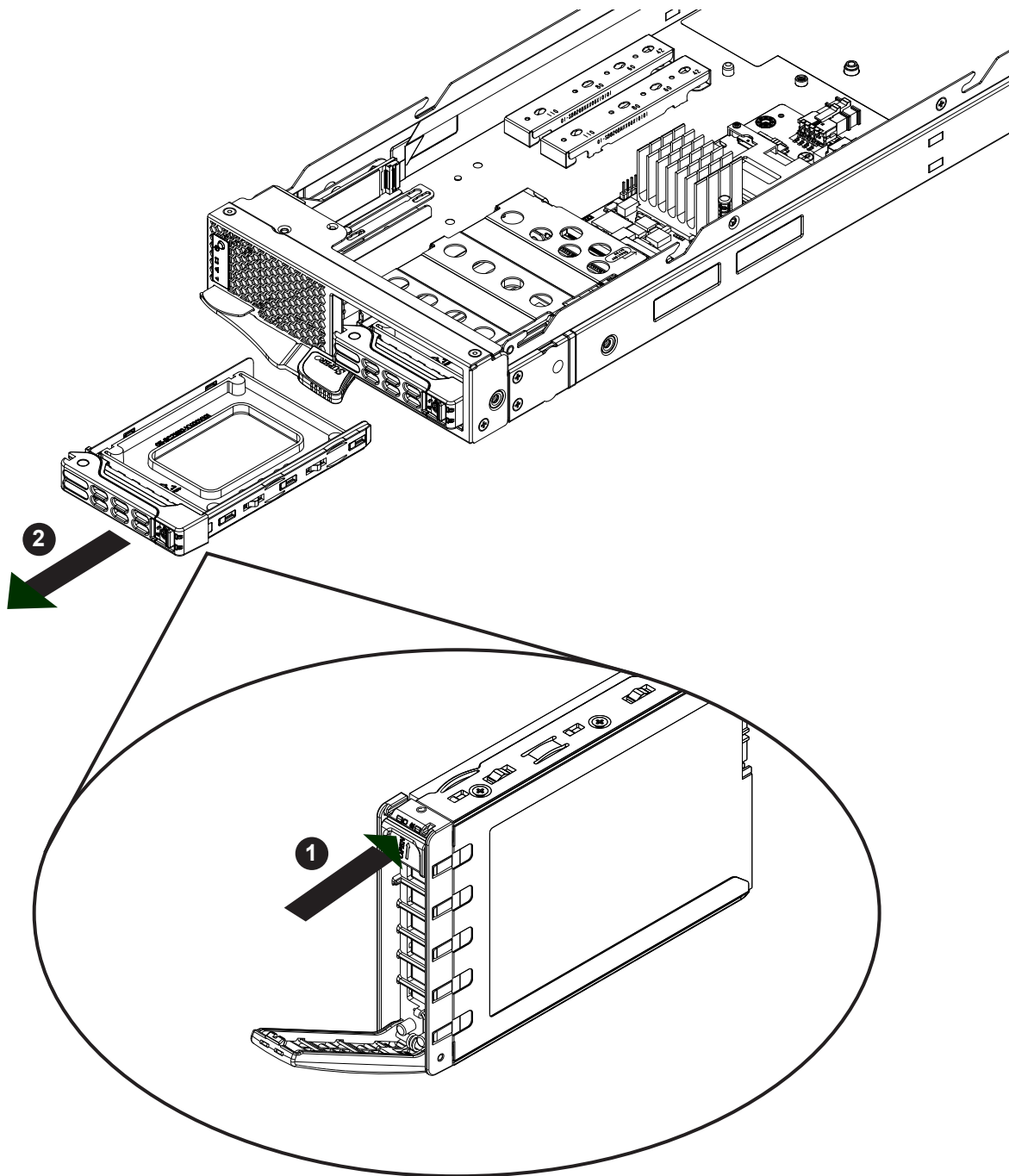

**Figure 2-14. Removing a Drive Carrier**

### ***Installing a Drive***

1. Remove the dummy drive, which comes pre-installed in the drive carrier, by removing the screws securing the dummy drive to the carrier. These screws are not used to mount the actual drive.

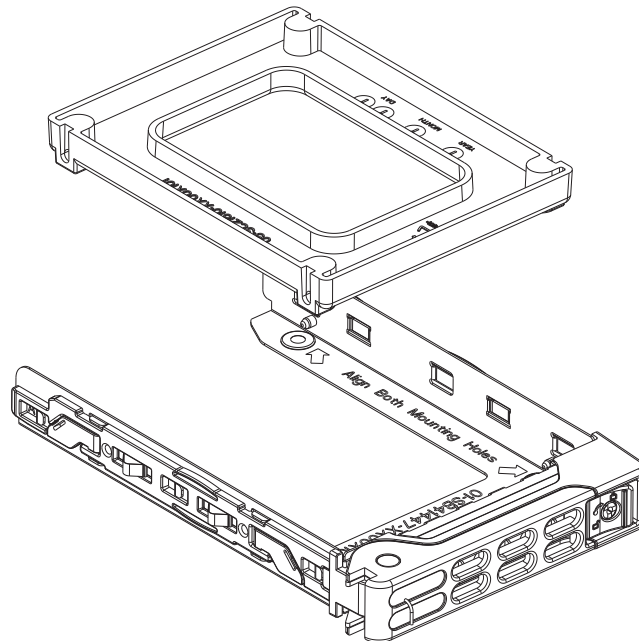

**Figure 2-15. Removing the Dummy Drive from a Carrier**

2. Insert a drive into the carrier with the PCB side facing down and the connector end toward the rear of the carrier. Align the drive in the carrier so that the screw holes line up. Note that there are holes in the carrier marked "SATA" to aid in correct installation.
3. Secure the drive to the carrier with four M3 screws as illustrated below. These screws are included in the chassis accessory box.
4. Insert the drive carrier with the disk drive into its bay, keeping the carrier oriented so that the hard drive is on the top of the carrier and the release button is on the right side. When the carrier reaches the rear of the bay, the release handle will retract.
5. Push the handle in until it clicks into its locked position

## Hot-Swap for NVMe Drives

Supermicro servers support NVMe surprise hot-swap. For even better data security, NVMe *orderly* hot-swap is recommended. NVMe drives can be ejected and replaced remotely using IPMI.

**Note:** If you are using VROC, see the VROC appendix in this manual instead.

### Ejecting a Drive

#### 1. IPMI > Server Health > NVMe SSD

2. Select Device, Group and Slot, and click **Eject**. After ejecting, the drive Status LED indicator turns green.
3. Remove the drive.

Note that *Device* and *Group* are categorized by the CPLD design architecture.

*Slot* is the slot number on which the NVMe drives are mounted.

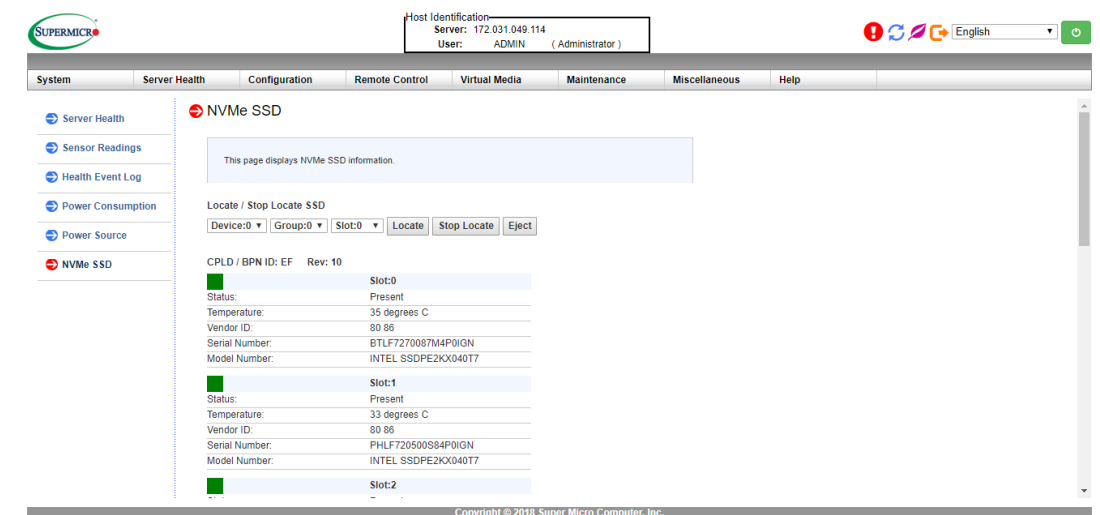

Figure 2-16. IPMI Screenshot

### Replacing the Drive

1. Insert the replacement drive.
2. IPMI > Server Health > NVMe SSD
3. Select Device, Group and slot and click **Insert**. The drive Status LED indicator flashes red, then turns off. The Activity LED turns blue.

## Checking the Temperature of an NVMe Drive

There are two ways to check using IPMI.

### *Checking a Drive*

- **IPMI > Server Health > NVMe SSD** – Shows the temperatures of all NVMe drives, as in Figure 3-4.
- **IPMI > Server Health > Sensor Reading > NVME\_SSD** – Shows the single highest temperature among all the NVMe drives.

## M.2 Solid State Drives

Up to two M.2 solid state drives (SSDs) can be installed, supporting PCIe. Several lengths are supported—42mm, 60mm 80mm or 110mm. For each length, there is an hole in the mounting platform for a plastic clasp.

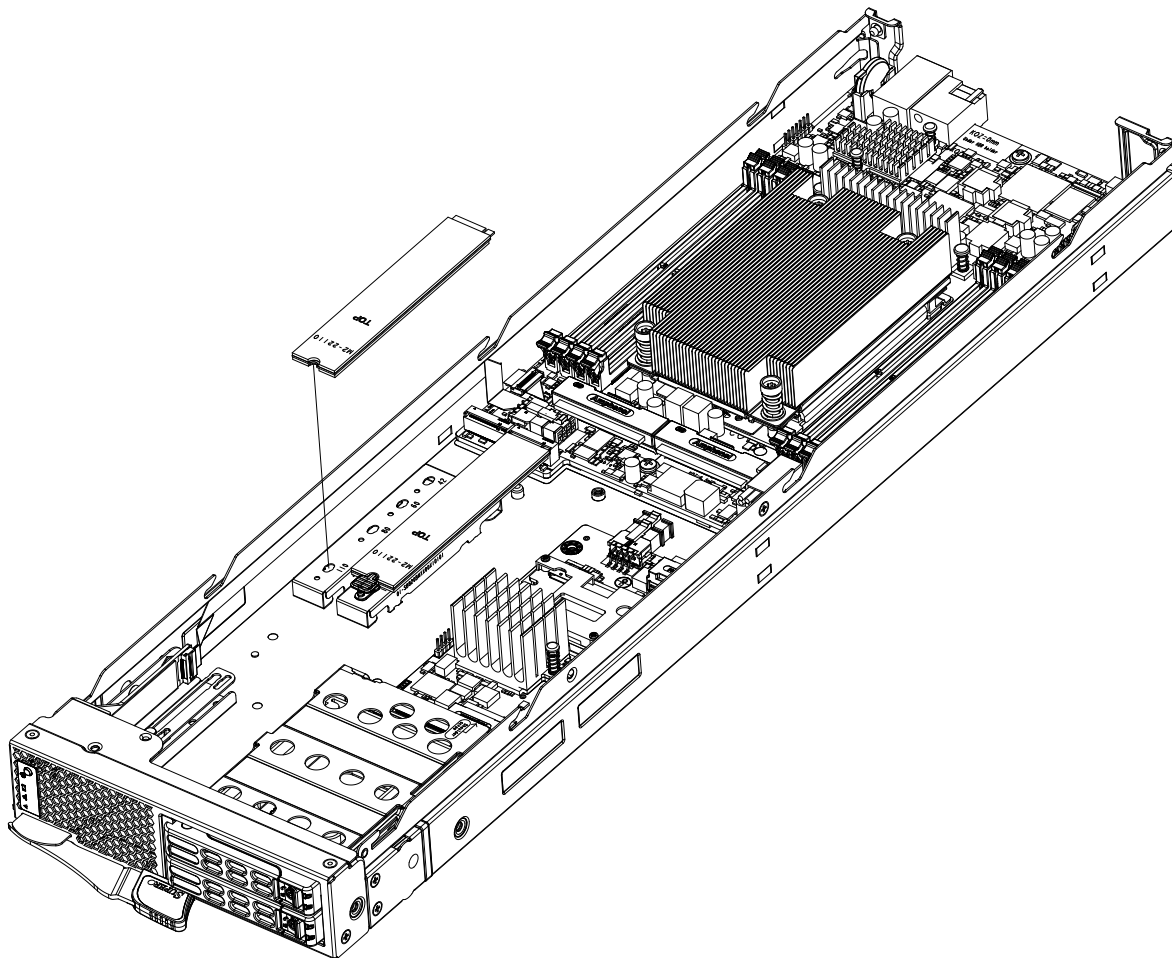

Figure 2-17. M.2 SSDs

### Installing an M.2 SSD

**Caution:** Use industry-standard anti-static equipment, such as gloves or wrist strap, and follow precautions to avoid damage caused by ESD.

1. Insert the SSD into the socket on the riser card. Then push it flat against the mounting platform.
2. Secure the SSD by firmly inserting the plastic plug.

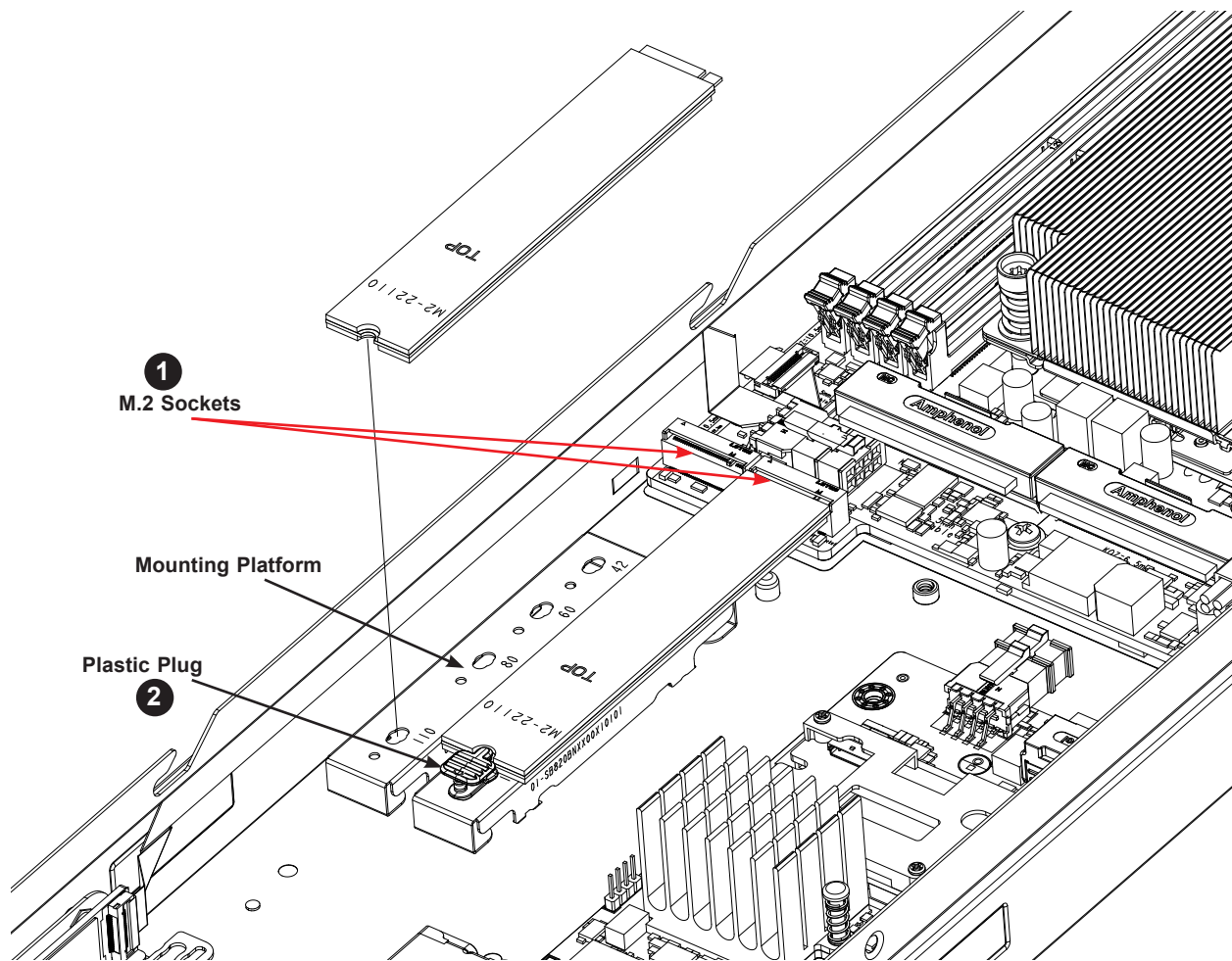

Figure 2-18. Installing M.2 SSDs

## 2.7 Installing the Mezzanine Card

1. Install the three standoffs as pictured below.
2. Align the mezzanine card with the connector on the motherboard and slip it in.
3. Secure it with three screws.

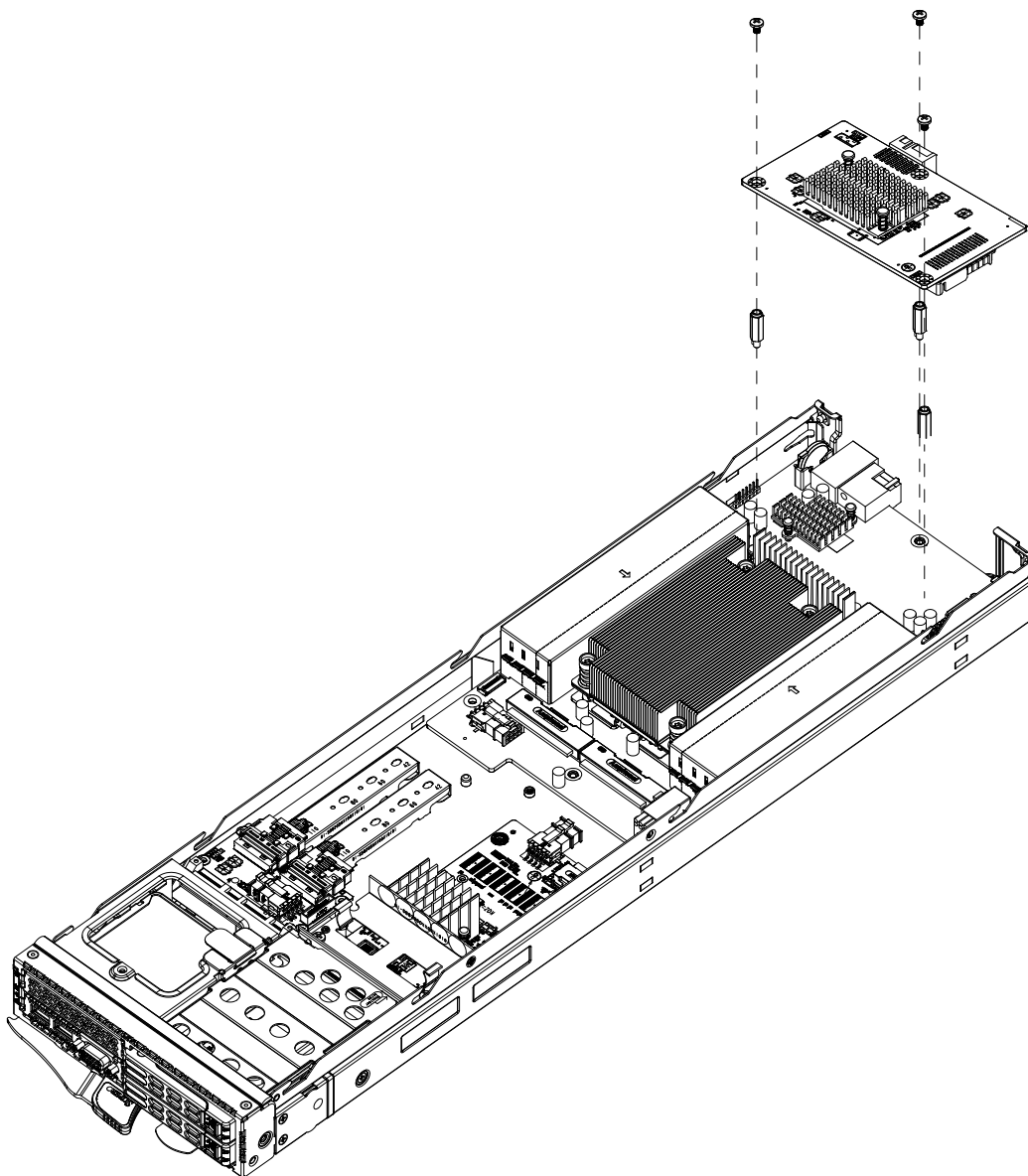

Figure 2-19. Installing the Mezzanine Card

## 2.8 Driver Installation

The Supermicro website contains drivers and utilities for your system at <https://www.supermicro.com/wftp/driver>. Some of these must be installed, such as the chipset driver.

After accessing the website, go into the CDR\_Images (in the parent directory of the above link) and locate the ISO file for your motherboard. Download this file to a USB flash drive or save as an ISO file on local storage. (You may also use a utility to extract the ISO file if preferred.) Then mount with virtual media at BMC console redirect with USB or ISO file to install.

Another option is to go to the Supermicro website at <http://www.supermicro.com/products/>. Find the product page for your motherboard, and "Download the Latest Drivers and Utilities".

Mount with virtual media and the screenshot shown below should appear.

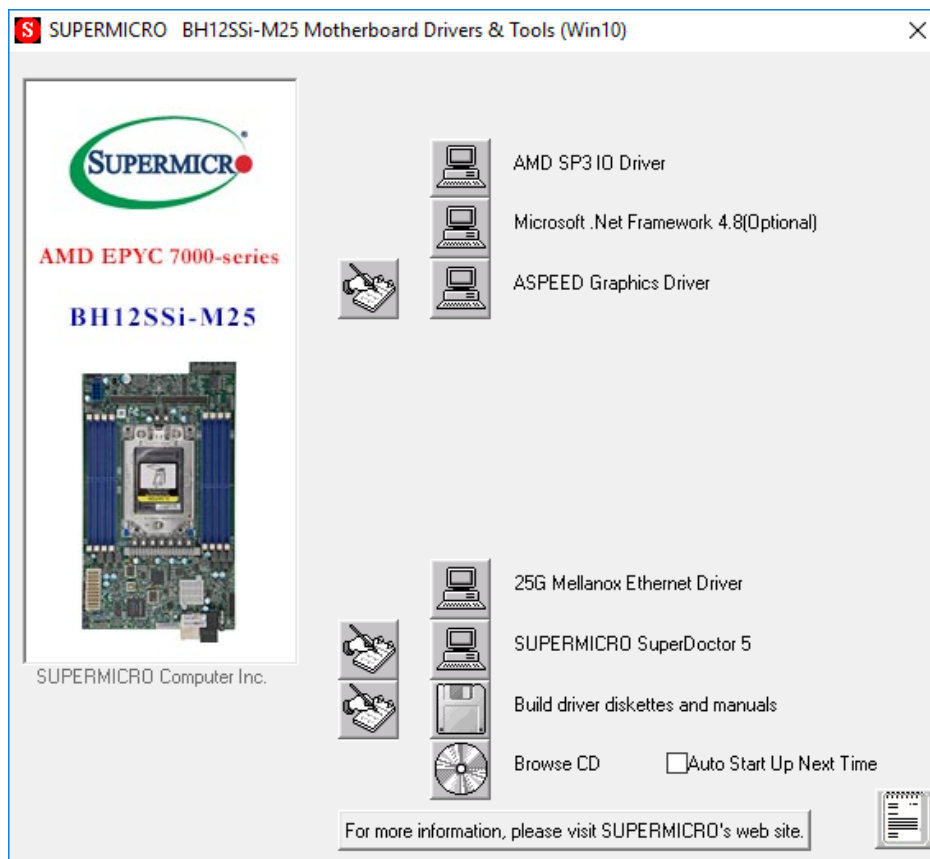

**Figure 2-20. Driver & Tool Installation Screen**

**Note:** Click the icons showing a hand writing on paper to view the readme files for each item. Click the computer icons to the right of these items to install each item (from top to the bottom) one at a time. **After installing each item, you must re-boot the system before moving on to the next item on the list.** The bottom icon with a CD on it allows you to view the entire contents.

## 2.9 Installing the Operating System

An operating system (OS) must be installed on each blade module. Blades with Microsoft Windows OS and blades with Linux OS can operate within the same blade enclosure. Refer to the [SuperMicro web site](#) for a list of supported operating systems.

### *Installing by using PXE Boot*

Preboot Execution Environment (PXE) is used to boot a computer over a network. To install the OS using PXE, the following conditions must be met:

- The PXE BOOT option in BIOS must be enabled.
- A PXE server has been configured; this can be another blade in the system.
- The PXE server must be connected over a network to the blade to be booted.
- The blade has only non-partitioned/unformatted hard drives installed and no bootable devices attached to it.

Once these conditions are met, make sure the PXE server is running. Then turn on the blade on which you wish to install the OS. The BIOS in the blade will look at all bootable devices and finding none, will connect to the PXE server to begin the boot/install.

### *Installing by using Virtual Media (Drive Redirection)*

You can install the OS via Virtual Media through either the IPMIview (Java-based client utility), SuperBladeTool or the Web-based Management Utility. With this method, the OS is installed from an ISO image that resides on another system.

Refer to the manuals on the [SuperMicro web site](#) for further details on the Virtual Media (CD-ROM or Drive Redirection) sections of these two utility programs.

### **Linux Installation with Two Storage Drives—Note**

When installing Linux with two storage drives on the SBA-4119S-T2N you may encounter a situation where one drive is recognized as HDA and the other drive is recognized as SDA. This is normal since in this case the connection for SATA HDDs is from two different controllers.

Under Native IDE mode (which is the default), your Linux OS will see one drive as HDA and the other as SDA. If the SATA controller mode operation is changed to AMD\_AHCI in the BIOS, then the HDDs will appear as SDA and SDB.

## 2.10 Configuring RAID

For RAID setup, see <http://www.supermicro.com/support/manuals/> under RAID Installation Guides.

# Chapter 3

## Management and Maintenance

This chapter provides instructions for managing the blade unit and performing maintenance on components.

See Chapter 2 for:

- Installing or removing the blade unit
- Powering up or down a blade unit
- Removing or replacing a storage drive
- Removing or installing the processor, heatsink, or memory

### 3.1 Management Software

System management may be performed with any of three software packages: IPMIview, IPMItool or a Web-based Management Utility. These are designed to provide an administrator with a comprehensive set of functions and monitored data to keep tabs on the system and perform management activities.

#### **BMC**

The motherboard provides remote access, monitoring and management through the baseboard management controller (BMC) and other management controllers distributed among different system modules. There are several BIOS settings that are related to BMC. For general documentation and information on BMC, visit our website at:

[www.supermicro.com/en/solutions/management-software/bmc-resources](http://www.supermicro.com/en/solutions/management-software/bmc-resources)

#### ***BMC ADMIN User Password***

For security, each system is assigned a unique default BMC password for the ADMIN user. This can be found on a sticker on the chassis, noted below, and a sticker on the motherboard. The sticker also displays the BMC MAC address.

For more information, refer to:

[https://www.supermicro.com/en/support/BMC\\_Unique\\_Password](https://www.supermicro.com/en/support/BMC_Unique_Password).



Figure 3-1. BMC Password Label

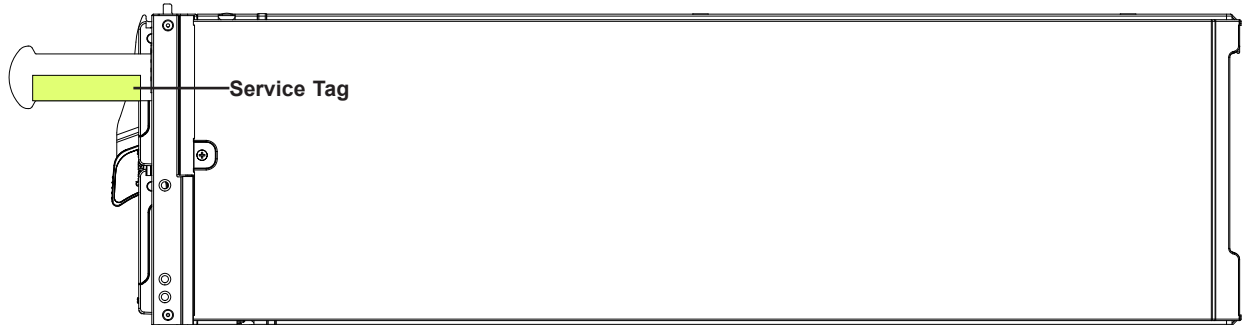

Figure 3-2. Service Tag Location on Blade Module

## 3.2 SuperDoctor® 5

The Supermicro SuperDoctor 5 is a program that functions in a command-line or web-based interface for Windows and Linux operating systems. The program monitors such system health information as CPU temperature, system voltages, system power consumption, fan speed, and provides alerts via email or Simple Network Management Protocol (SNMP).

SuperDoctor 5 comes in local and remote management versions and can be used with Nagios to maximize your system monitoring needs. With SuperDoctor 5 Management Server (SSM Server), you can remotely control power on/off and reset chassis intrusion for multiple systems with SuperDoctor 5 or IPMI. SuperDoctor 5 Management Server monitors HTTP, FTP, and SMTP services to optimize the efficiency of your operation.

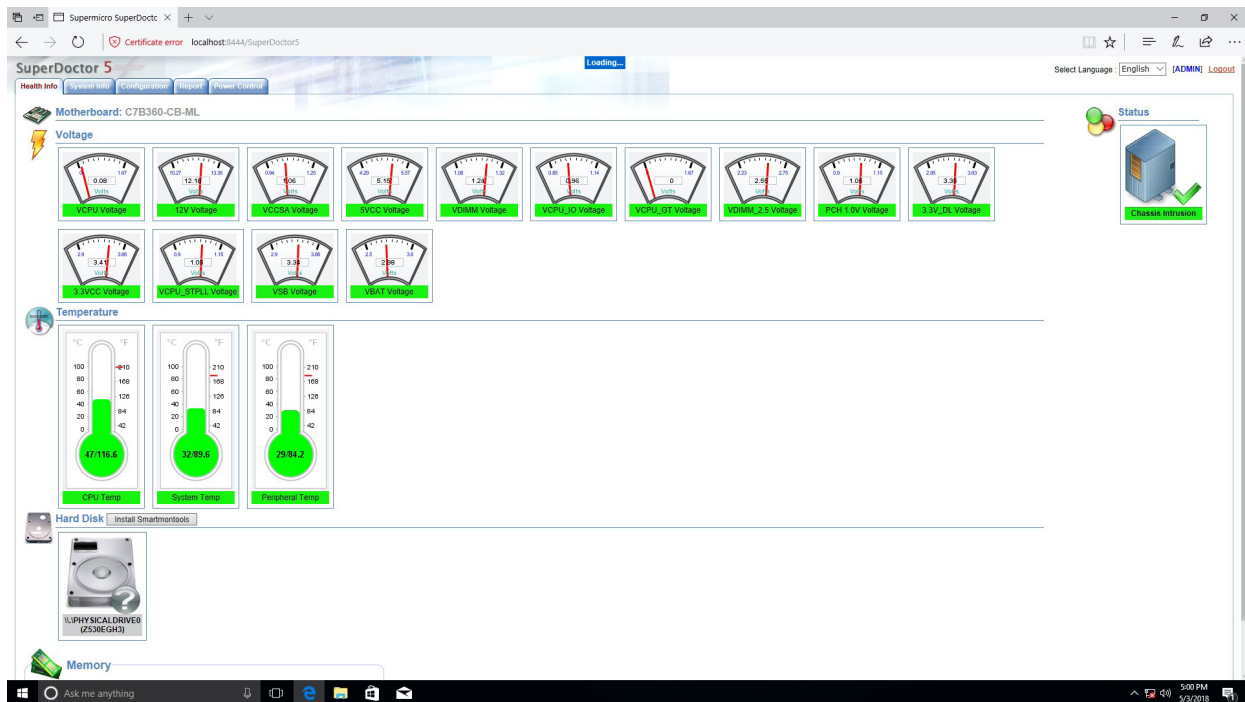

Figure 3-3. SuperDoctor 5 Interface Display Screen (Health Information)

### 3.3 Motherboard Battery

The motherboard uses non-volatile memory to retain system information when system power is removed. This memory is powered by a lithium battery residing on the motherboard.

#### ***Replacing the Battery***

Begin by removing power from the system as described in section 3.1.

1. Push aside the small clamp that covers the edge of the battery. When the battery is released, lift it out of the holder.
2. To insert a new battery, slide one edge under the lip of the holder with the positive (+) side facing up. Then push the other side down until the clamp snaps over it.

**Note:** Handle used batteries carefully. Do not damage the battery in any way; a damaged battery may release hazardous materials into the environment. Do not discard a used battery in the garbage or a public landfill. Please comply with the regulations set up by your local hazardous waste management agency to dispose of your used battery properly.

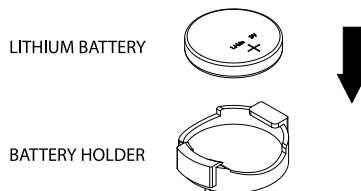

**Figure 3-4. Installing the Onboard Battery**

**Warning:** There is a danger of explosion if the onboard battery is installed upside down (which reverses its polarities). This battery must be replaced only with the same or an equivalent type recommended by the manufacturer (CR2032).

## 3.4 System Cooling

### Installing the Air Shrouds

Air shrouds concentrate airflow to maximize fan efficiency. These do not require screws to install.

#### *Installing the Air Shrouds*

- Position the air shrouds as illustrated in the figure below, sliding the front notch over the pin on the fan tray.

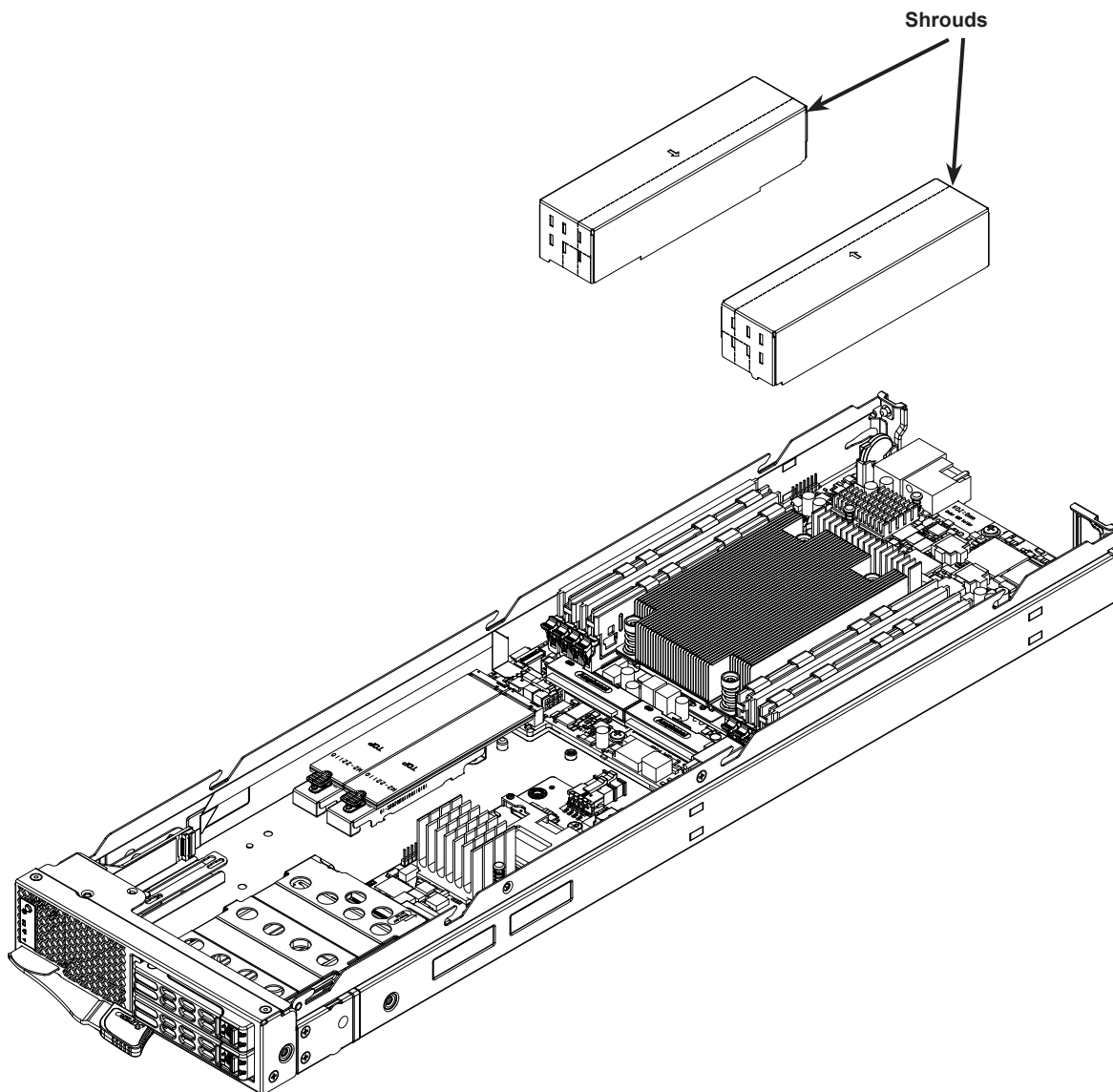

Figure 3-5. Installing the Standard Air Shrouds

## Checking the Server Air Flow

- Make sure there are no objects to obstruct airflow in and out of the server.
- Do not operate the server without drives or drive carriers in the drive bays.
- Use only recommended server parts.
- Make sure no wires or foreign objects obstruct air flow through the chassis. Pull all excess cabling out of the airflow path or use shorter cables.

The control panel LEDs display system heat status. See “Control Panel” in Chapter 1 for details.

## Overheating

There are several possible responses if the system overheats.

- Use the LEDs to determine the nature of the overheating condition.
- Confirm that the chassis covers are installed properly.
- Make sure all fans are present and operating normally.
- Check the routing of the cables.
- Verify that the heatsinks are installed properly.

### 3.5 Where to Get Replacement Components

If you need replacement parts for your system, to ensure the highest level of professional service and technical support, purchase exclusively from our Supermicro Authorized Distributors/System Integrators/Resellers. A list can be found at: [www.supermicro.com](http://www.supermicro.com). Click the menu icon > **Buy** > **Where to Buy** link.

### 3.6 Returning Merchandise for Service

A receipt or copy of your invoice marked with the date of purchase is required before any warranty service will be rendered. You can obtain service by calling your vendor for a Returned Merchandise Authorization (RMA) number. When returning to the manufacturer, the RMA number should be prominently displayed on the outside of the shipping carton, and mailed prepaid or hand-carried. Shipping and handling charges will be applied for all orders that must be mailed when service is complete.

For faster service, RMA authorizations may be requested online (<https://www.supermicro.com/support/rma/>).

Whenever possible, repack the chassis in the original Supermicro carton, using the original packaging material. If these are no longer available, be sure to pack the chassis securely, using packaging material to surround the chassis so that it does not shift within the carton and become damaged during shipping.

This warranty only covers normal consumer use and does not cover damages incurred in shipping or from failure due to the alteration, misuse, abuse or improper maintenance of products.

During the warranty period, contact your distributor first for any product problems.

## Chapter 4

# Motherboard Connections

This section describes the jumpers, connectors, and status LEDs on the motherboard and provides pinout definitions. Depending on how the system is configured, not all connections are required.

Please review the [Safety Precautions](#) in Appendix B before installing or removing components.

### Main Connectors



**A.** 2X PCIe Gen 4 x16 connector for MCIO cable

**B.** 2X M.2 Connector (PCIe Gen 4 x4 or 2 SATA support)

**C.** Front panel control connector (LED and power button)

**D.** PCIe Gen 4 x16 Mezzanine card connector

**E.** Keyboard, video & mouse port

**F.** IPMI and on-board LAN connector to enclosure (middle plane)

**G.** Motherboard power connector to middle plane

## 4.1 Motherboard Layout

Below is a layout of the BH12SSi-M25 with jumper, connector and LED locations shown. See the table on the following page for descriptions.

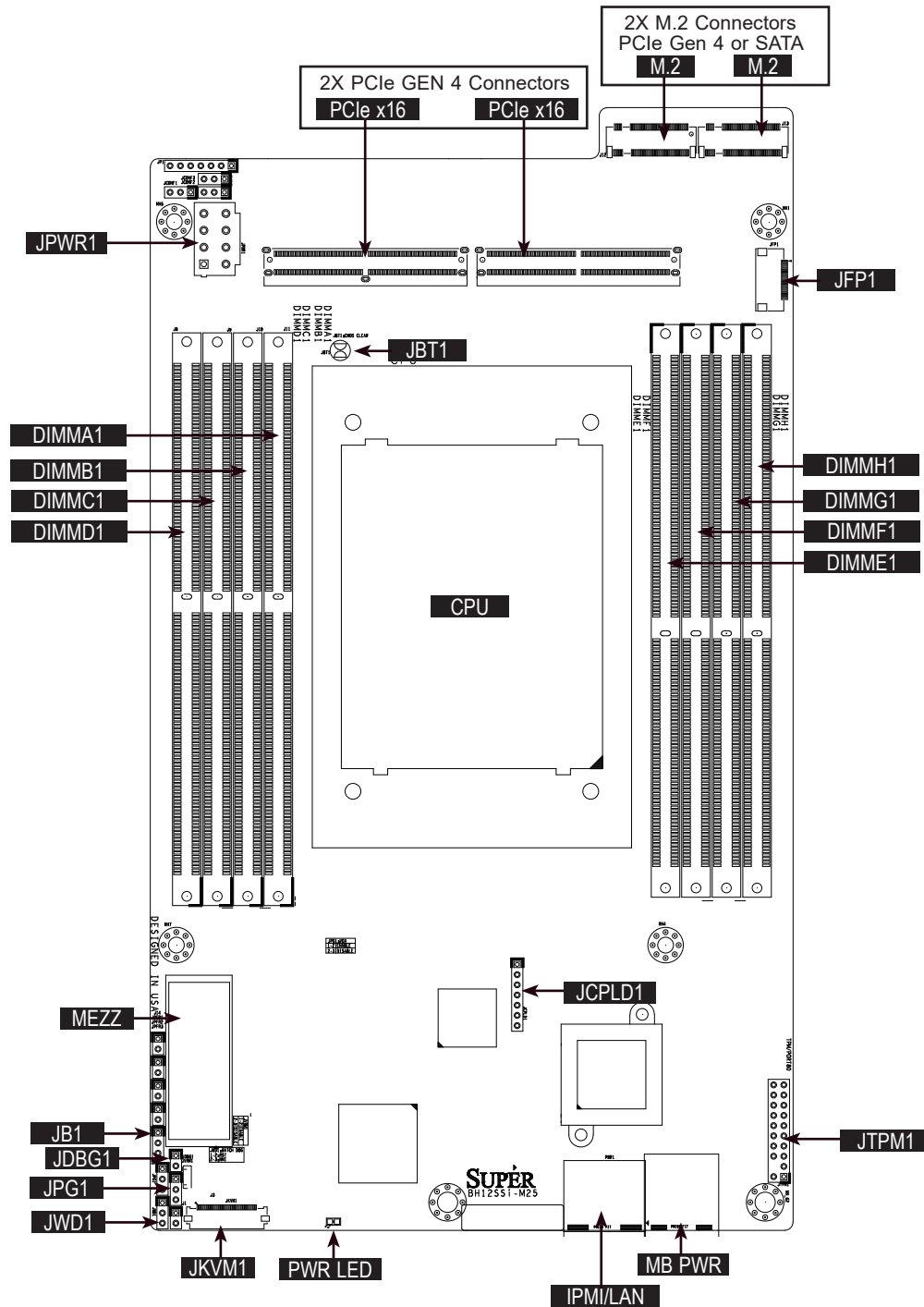

Figure 4-1. Motherboard Layout

## Quick Reference

| Jumper | Description                  | Default Setting    |
|--------|------------------------------|--------------------|
| JDBG1  | Debug Mode                   | Pins 1-2 (Enabled) |
| JBT1   | Clear CMOS                   | Open (Normal)      |
| JWD1   | Watch Dog Timer control      | Pins 1-2 (Reset)   |
| JPG1   | Onboard Video Disable/Enable | Pins 1-2 (Enabled) |

| Connector     | Description  |
|---------------|--|
| JB1           | External speaker/buzzer connector                      |
| JCPLD1        | Complex-Programmable Logical Device (CPLD) header      |
| JKVM1         | Connector for external keyboard, video and mouse       |
| JFP1          | Front control panel connector for LED and Power Button |
| IPMI/LAN      | IPMI/LAN connector                                     |
| JTPM1         | Trusted Platform Module (TPM)/Port 80 connector        |
| 2x PCIe x16   | 2x PCIe Gen 4 x16 connectors for MCIO cable            |
| 2x M.2        | 2x M.2 Connector (PCIe Gen 4 x4 or 2X SATA support)    |
| MEZZ          | PCIe Gen 4 x16 Mezzanine card connector                |
| MB PWR        | Motherboard power connector to middle plane            |
| DIMMA1~DIMMH1 | DIMM memory slots                                      |
| JPWR1         | 12V 8-pin ATX CPU power connector                      |

| LED     | Description | Status       |
|---------|-------------|--------------|
| PWR LED | Power LED   | On: Power On |

**Note:** Jumpers, connectors, switches, and LED indicators that are not described in the preceding tables are for manufacturing testing purposes only, and are not covered in this manual.

**Note:** A system block diagram is displayed in Chapter 1.

## 4.2 Headers and Connectors

### 12V 8-pin Power Connector (JPWR1)

JPWR1 is an 8-pin ATX power input to provide power to the motherboard.

| 12V 8-pin Power Connector<br>Pin Definitions |            |
|--|------------|
| Pins   | Definition |
| 1 through 4                                  | Ground     |
| 5 through 8                                  | +12V       |

### TPM Header

The JTPM1 header is used to connect a Trusted Platform Module (TPM)/Port 80, which is available from Supermicro. A TPM/Port 80 connector is a security device that supports encryption and authentication in hard drives. It allows the motherboard to deny access if the TPM associated with the storage drive is not installed in the system.

For more information on TPM: <http://www.supermicro.com/manuals/other/TPM.pdf>.

| Trusted Platform Module/Port 80 Header<br>Pin Definitions |                |      |                |
|---|----------------|------|----------------|
| Pin#  | Definition     | Pin# | Definition     |
| 1   | P3V3           | 2    | SPI_TPM_CS_N   |
| 3   | PCI-E_RESET_N# | 4    | SPI_PCH_MISO   |
| 5   | SPI_PCH_CLK#   | 6    | Ground         |
| 7   | SPI_PCH_MOSI   | 8    | N/A            |
| 9   | JTPM1_P3V3A    | 10   | IRQ_TPM_SPIN_N |

### M.2 Connectors

The PCIe M.2 supports M-Key (PCIe x2) storage cards. M.2-C1 can support a speed of PCIe x4, when one M.2 device is installed.

## 4.3 Jumpers

To modify the operation of the motherboard, jumpers are used to choose between optional settings. Jumpers create shorts between two pins to change the function associated with it. Pin 1 is identified with a square solder pad on the printed circuit board. See the motherboard layout page for jumper locations.

**Note:** On a two-pin jumper, "Closed" means the jumper is on both pins and "Open" indicates the jumper is either on only one pin or has been completely removed.

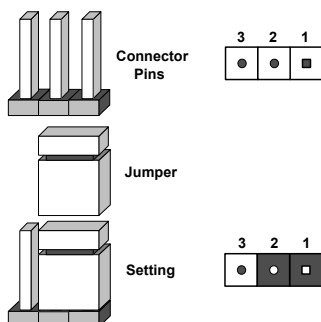

### CMOS Clear

JBT1 is used to clear CMOS, which will also clear any passwords. Instead of pins, this jumper consists of contact pads to prevent accidentally clearing the contents of CMOS.

#### To Clear CMOS

1. First power down the system and unplug the power cord(s).
2. Remove the cover of the chassis to access the motherboard.
3. Remove the onboard battery from the motherboard.
4. Short the CMOS pads with a metal object such as a small screwdriver for at least four seconds.
5. Remove the screwdriver (or shorting device).
6. Replace the cover, reconnect the power cord(s) and power on the system.

**Notes:** Clearing CMOS will also clear all passwords.

Do not use the PW\_ON connector to clear CMOS.



JBT1 contact pads

### Watch Dog (JWD1)

JWD1 controls the Watch Dog function. Watch Dog is a monitor that can reboot the system when a software application hangs. Jumping pins 1-2 will cause Watch Dog to reset the system if an application hangs. Jumping pins 2-3 will generate a non-maskable interrupt signal for the application that hangs. Watch Dog must also be enabled in BIOS. The default setting is Reset.

**Note:** When Watch Dog is enabled, the user must write their own application software to disable it.

| Watch Dog<br>Jumper Settings |                 |
|------------------------------|-----------------|
| Jumper Setting               | Definition      |
| Pins 1-2                     | Reset (Default) |
| Pins 2-3                     | NMI             |
| Open                         | Disabled        |

### Debug Mode Enable/Disable (JDBG1)

Jumper JDBG1 will enable or disable Debug Mode on the motherboard. The default setting is Normal Mode.

| Debug Mode Enable/Disable<br>Jumper Settings (JDBG1) |                       |
|--|-----------------------|
| Jumper Setting                                       | Definition            |
| Pins 1-2   | Normal Mode (default) |
| Pins 2-3   | Debug Mode            |

### VGA Enable/Disable (JPG1)

JPG1 allows you to enable or disable the VGA port. The default position is Enabled.

| VGA Enable/Disable<br>Jumper Settings (JPG1) |                   |
|--|-------------------|
| Jumper Setting                               | Definition        |
| Pins 1-2                                     | Enabled (default) |
| Pins 2-3                                     | Disabled          |

## 4.4 LED Indicators

### Onboard Power LED (PWR LED)

When the PWR LED is illuminated, the system is turned on and all the system power rails are ready. When the system is turned off, or any one of the system power rails fails, this LED will turn off.

| Onboard Power LED Indicator |  |
|-----------------------------|--|
| LED Color                   | Definition                             |
| Off                         | System Off (power cable not connected) |
| Green                       | System On, Power OK                    |

# Chapter 5

## UEFI BIOS

### 5.1 Introduction

This chapter describes the AMI UEFI BIOS setup utility for the BH12SSi-M25 and provides the instructions on navigating the setup screens. The BIOS is stored in a Flash EEPROM and can be updated.

**Note:** Due to periodic changes to the BIOS, some settings may have been added or deleted since this manual was published.

#### Starting BIOS Setup Utility

To enter the BIOS setup utility screens, press the <Delete> key while the system is booting up. (There are a few cases when other keys are used, such as <F1>, <F2>, etc.)

The BIOS screens have three main frames. The large left frame displays options can be configured by the user. These are blue. When an option is selected, it is highlighted in white. Settings printed in **Bold** are the default values.

In the left frame, a " ►" indicates a submenu. Highlighting such an item and pressing the <Enter> key opens the list of settings in that submenu.

The upper right frame displays helpful information for the user. The AMI BIOS has default informational messages built in. The manufacturer retains the option to include, omit, or change any of these informational messages.

The lower right frame lists navigational methods. The AMI BIOS setup utility uses a key-based navigation system called *hot keys*. Most of these hot keys can be used at any time during setup navigation. These keys include <F3>, <F4>, <Enter>, <ESC>, arrow keys, etc.

Some system parameters may be changed.

### 5.2 Main Setup

When running the BIOS setup utility, it starts with the Main screen. You can always return to it by selecting the Main tab on the top of the screen.

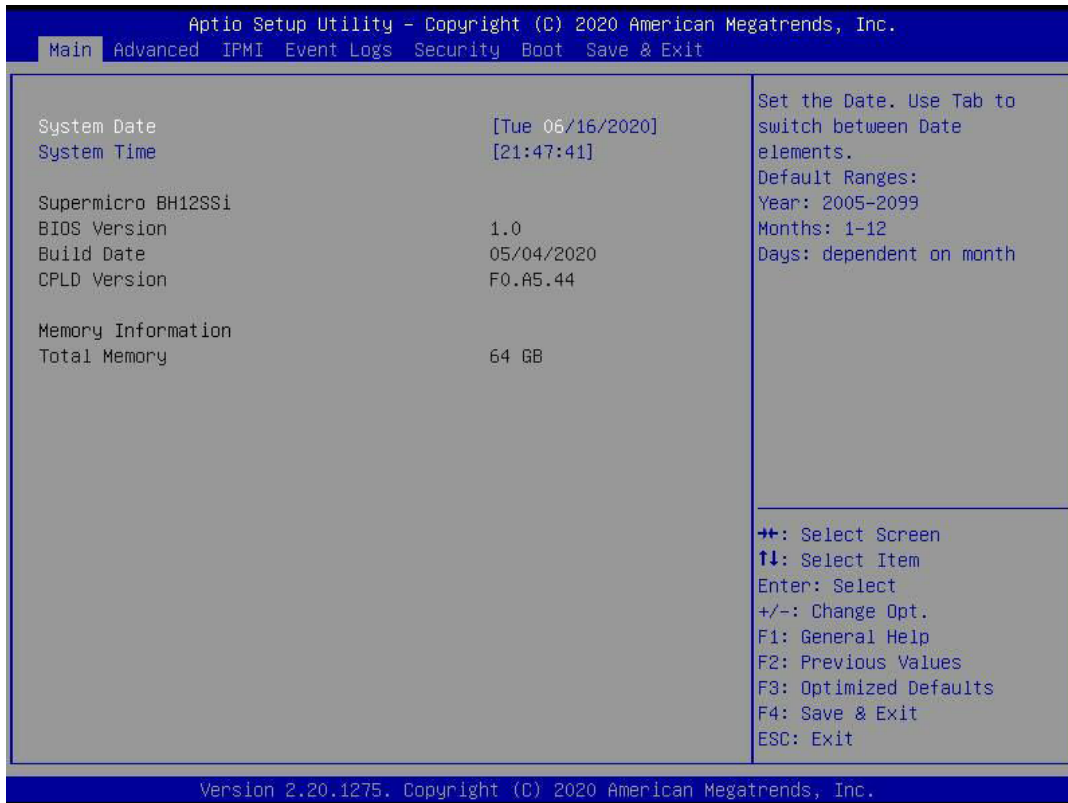

The Main tab page allows you to set the date and time, and it displays system information.

### System Date/System Time

Use this option to change the system date and time. Highlight *System Date* or *System Time* using the arrow keys. Enter new values using the keyboard. Press the <Tab> key or the arrow keys to move between fields. The date must be entered in MM/DD/YYYY format. The time is entered in HH:MM:SS format.

**Note:** The time is in the 24-hour format. For example, 5:30 P.M. appears as 17:30:00. The date's default value is 01/01/2016 after RTC reset.

### Supermicro BH12SSi-M25 (Motherboard model)

#### BIOS Version

#### Build Date (of the BIOS)

**CPLD (Complex Programmable Logic Device) Version:** This item displays the CPLD version used in the system.

#### Memory Information

#### Total Memory (for the system)

## 5.3 Tab Pages

### Advanced

- Boot Function
- Trusted Computing
- PSP Firmware Versions
- Super IO Configuration
- Serial Port Console Redirection
- CPU Configuration
- NB Configuration
- AMI Graphic Output Protocol Policy
- PCIe/PCI/PnP Configuration
- USB Configuration
- SATA Configuration
- HTTP BOOT Configuration
- Network Configuration
- iSCSI Configuration
- TLS Authenticate Configuration
- RAM Disk Configuration
- Avago MegaRAID Configuration Utility
- Driver Health

### IPMI

- Update IPMI LAN Configuration
- IPv4 Support: Configuration Address Source, VLAN
- IPv6 Support: Configuration Address Source

### Event Logs

- Change SMBIOS Event Log Settings
- ViewSMBOIS Event Log

### Security

- Administrator Password
- Password Check
- Secure Boot

### Boot

- Boot Mode Select
- Legacy to EFI Support
- Boot Priorities

**Save & Exit**

Save Options

Default Options

Boot Override

# Appendix A

## BIOS POST Codes

### A.1 BIOS POST Messages

During the Power-On Self-Test (POST), the BIOS will check for problems. If a problem is found, the BIOS will activate an alarm or display a message. The following is a list of such BIOS messages.

| BIOS POST Messages                                    |  |
|---|--|
| BIOS Message  | Description  |
| Failure Fixed Disk                                    | Fixed disk is not working or not configured properly. Check to see if fixed disk is attached properly. Run Setup. Find out if the fixed-disk type is correctly identified.   |
| Stuck key   | Stuck key on keyboard.   |
| Keyboard error  | Keyboard not working.  |
| Keyboard Controller Failed                            | Keyboard controller failed test. May require replacing keyboard controller.  |
| Keyboard locked - Unlock key switch                   | Unlock the system to proceed.  |
| Monitor type does not match CMOS - Run SETUP          | Monitor type not correctly identified in Setup   |
| Shadow Ram Failed at offset: nnnn                     | Shadow RAM failed at offset nnnn of the 64k block at which the error was detected.   |
| System RAM Failed at offset: nnnn                     | System RAM failed at offset nnnn of in the 64k block at which the error was detected.  |
| Extended RAM Failed at offset: nnnn                   | Extended memory not working or not configured properly at offset nnnn.   |
| System battery is dead - Replace and run SETUP        | The CMOS clock battery indicator shows the battery is dead. Replace the battery and run Setup to reconfigure the system.   |
| System CMOS checksum bad - Default configuration used | System CMOS has been corrupted or modified incorrectly, perhaps by an application program that changes data stored in CMOS. The BIOS installed Default Setup Values. If you do not want these values, enter Setup and enter your own values. If the error persists, check the system battery or contact your dealer. |
| System timer error                                    | The timer test failed. Requires repair of system board.  |
| Real time clock error                                 | Real-Time Clock fails BIOS hardware test. May require board repair.  |
| Check date and time settings                          | BIOS found date or time out of range and reset the Real-Time Clock. May require setting legal date (1991-2099).  |

| <b>BIOS POST Messages</b>                             |  |
|---|--|
| <b>BIOS Message</b>                                   | <b>Description</b>   |
| Previous boot incomplete - Default configuration used | Previous POST did not complete successfully. POST loads default values and offers to run Setup. If the failure was caused by incorrect values and they are not corrected, the next boot will likely fail. On systems with control of wait states, improper Setup settings can also terminate POST and cause this error on the next boot. Run Setup and verify that the waitstate configuration is correct. This error is cleared the next time the system is booted. |
| Memory Size found by POST differed from CMOS          | Memory size found by POST differed from CMOS.  |
| Diskette drive A error                                |  |
| Diskette drive B error                                | Drive A: or B: is present but fails the BIOS POST diskette tests. Check to see that the drive is defined with the proper diskette type in Setup and that the diskette drive is attached correctly.   |
| Incorrect Drive A type - run SETUP                    | Type of floppy drive A: not correctly identified in Setup.   |
| Incorrect Drive B type - run SETUP                    | Type of floppy drive B: not correctly identified in Setup.   |
| System cache error - Cache disabled                   | RAM cache failed and BIOS disabled the cache. On older boards, check the cache jumpers. You may have to replace the cache. See your dealer. A disabled cache slows system performance considerably.  |
| CPU ID:   | CPU socket number for Multi-Processor error.   |
| EISA CMOS not writeable                               | ServerBIOS2 test error: Cannot write to EISA CMOS.   |
| DMA Test Failed                                       | ServerBIOS2 test error: Cannot write to extended DMA (Direct Memory Access) registers.   |
| Software NMI Failed                                   | ServerBIOS2 test error: Cannot generate software NMI (Non-Maskable Interrupt).   |
| Fail-Safe Timer NMI Failed                            | ServerBIOS2 test error: Fail-Safe Timer takes too long.  |
| device Address Conflict                               | Address conflict for specified device.   |
| Allocation Error for: device                          | Run ISA or EISA Configuration Utility to resolve resource conflict for the specified device.   |
| CD ROM Drive  | CD ROM Drive identified.   |
| Entering SETUP...                                     | Starting Setup program   |
| Failing Bits: nnnn                                    | The hex number nnnn is a map of the bits at the RAM address which failed the memory test. Each 1 (one) in the map indicates a failed bit. See errors 230, 231, or 232 above for offset address of the failure in System, Extended, or Shadow memory.   |
| Fixed Disk n  | Fixed disk n (0-3) identified.   |
| Invalid System Configuration Data                     | Problem with NVRAM (CMOS) data.  |
| I/O device IRQ conflict                               | I/O device IRQ conflict error.   |
| PS/2 Mouse Boot Summary Screen:                       | PS/2 Mouse installed.  |

| BIOS POST Messages   |  |
|--|--|
| BIOS Message   | Description  |
| nnnn kB Extended RAM Passed  | Where nnnn is the amount of RAM in kilobytes successfully tested.  |
| nnnn Cache SRAM Passed   | Where nnnn is the amount of system cache in kilobytes successfully tested.   |
| nnnn kB Shadow RAM Passed  | Where nnnn is the amount of shadow RAM in kilobytes successfully tested.   |
| nnnn kB System RAM Passed  | Where nnnn is the amount of system RAM in kilobytes successfully tested.   |
| One or more I2O Block Storage Devices were excluded from the Setup Boot Menu | There was not enough room in the IPL table to display all installed I2O block-storage devices.   |
| Operating system not found   | Operating system cannot be located on either drive A: or drive C:. Enter Setup and see if fixed disk and drive A: are properly identified.   |
| Parity Check 1 nnnn  | Parity error found in the system bus. BIOS attempts to locate the address and display it on the screen. If it cannot locate the address, it displays ????. Parity is a method for checking errors in binary data. A parity error indicates that some data has been corrupted.                                      |
| Parity Check 2 nnnn  | Parity error found in the I/O bus. BIOS attempts to locate the address and display it on the screen. If it cannot locate the address, it displays ????.  |
| Press <F1> to resume, <F2> to Setup, <F3> for previous                       | Displayed after any recoverable error message. Press <F1> to start the boot process or <F2> to enter Setup and change the settings. Press <F3> to display the previous screen (usually an initialization error of an Option ROM, i.e., an add-on card). Write down and follow the information shown on the screen. |
| Press <F2> to enter Setup  | Optional message displayed during POST. Can be turned off in Setup.  |
| PS/2 Mouse:  | PS/2 mouse identified.   |
| Run the I2O Configuration Utility  | One or more unclaimed block storage devices have the Configuration Request bit set in the LCT. Run an I2O Configuration Utility (e.g. the SAC utility).  |
| System BIOS shadowed   | System BIOS copied to shadow RAM.  |
| UMB upper limit segment address: nnnn  | Displays the address nnnn of the upper limit of Upper Memory Blocks, indicating released segments of the BIOS which can be reclaimed by a virtual memory manager.  |
| Video BIOS shadowed  | Video BIOS successfully copied to shadow RAM.  |

## A.2 BIOS POST Codes

This section lists the POST (Power-On Self-Test) codes for the AMI BIOS. POST codes are divided into two categories: recoverable and terminal.

### Recoverable POST Errors

When a recoverable type of error occurs during POST, the BIOS will display an POST code that describes the problem. BIOS may also issue one of the following beep codes:

One long and two short beeps – video configuration error

One repetitive long beep – no memory detected

## Terminal POST Errors

If a terminal type of error occurs, BIOS will shut down the system. Before doing so, BIOS will write the error to port 80h, attempt to initialize video and write the error in the top left corner of the screen.

The following is a list of codes that may be written to port 80h.

| Terminal POST Errors |   |
|----------------------|---|
| Code                 | Description                                       |
| 02h                  | Verify Real Mode                                  |
| 03h                  | Disable Non-Maskable Interrupt (NMI)              |
| 04h                  | Get CPU type                                      |
| 06h                  | Initialize system hardware                        |
| 07h                  | Disable shadow and execute code from the ROM.     |
| 08h                  | Initialize chipset with initial POST values       |
| 09h                  | Set IN POST flag                                  |
| 0Ah                  | Initialize CPU registers                          |
| 0Bh                  | Enable CPU cache                                  |
| 0Ch                  | Initialize caches to initial POST values          |
| 0Eh                  | Initialize I/O component                          |
| 0Fh                  | Initialize the local bus IDE                      |
| 10h                  | Initialize Power Management                       |
| 11h                  | Load alternate registers with initial POST values |
| 12h                  | Restore CPU control word during warm boot         |
| 13h                  | Initialize PCI Bus Mastering devices              |
| 14h                  | Initialize keyboard controller                    |
| 16h                  | 1-2-2-3 BIOS ROM checksum                         |
| 17h                  | Initialize cache before memory Auto size          |
| 18h                  | 8254 timer initialization                         |
| 1Ah                  | 8237 DMA controller initialization                |
| 1Ch                  | Reset Programmable Interrupt Controller           |
| 20h                  | 1-3-1-1 Test DRAM refresh                         |
| 22h                  | 1-3-1-3 Test 8742 Keyboard Controller             |
| 28h                  | Auto size DRAM                                    |

| <b>Terminal POST Errors</b> |  |
|-----------------------------|--|
| <b>Code</b>                 | <b>Description</b>   |
| 29h                         | Initialize POST Memory Manager                                   |
| 2Ah                         | Clear 512 kB base RAM  |
| 2Ch                         | 1-3-4-1 RAM failure on address line xxxx*                        |
| 2Eh                         | 1-3-4-3 RAM failure on data bits xxxx* of low byte of memory bus |
| 2Fh                         | Enable cache before system BIOS shadow                           |
| 32h                         | Test CPU bus-clock frequency                                     |
| 33h                         | Initialize Phoenix Dispatch Manager                              |
| 36h                         | Warm start shut down   |
| 38h                         | Shadow system BIOS ROM   |
| 3Ah                         | Auto size cache  |
| 3Ch                         | Advanced configuration of chipset registers                      |
| 3Dh                         | Load alternate registers with CMOS values                        |
| 41h                         | Initialize extended memory for RomPilot                          |
| 42h                         | Initialize interrupt vectors                                     |
| 45h                         | POST device initialization                                       |
| 46h                         | 2-1-2-3 Check ROM copyright notice                               |
| 47h                         | Initialize I20 support   |
| 48h                         | Check video configuration against CMOS                           |
| 49h                         | Initialize PCI bus and devices                                   |
| 4Ah                         | Initialize all video adapters in system                          |
| 4Bh                         | QuietBoot start (optional)                                       |
| 4Ch                         | Shadow video BIOS ROM  |
| 4Eh                         | Display BIOS copyright notice                                    |
| 4Fh                         | Initialize MultiBoot   |
| 50h                         | Display CPU type and speed                                       |
| 51h                         | Initialize EISA board  |
| 52h                         | Test keyboard  |
| 54h                         | Set key click if enabled   |
| 55h                         | Enable USB devices   |

| <b>Terminal POST Errors</b> |  |
|-----------------------------|--|
| <b>Code</b>                 | <b>Description</b>                             |
| 58h                         | 2-2-3-1 Test for unexpected interrupts         |
| 59h                         | Initialize POST display service                |
| 5Ah                         | Display prompt "Press F2 to enter SETUP"       |
| 5Bh                         | Disable CPU cache                              |
| 5Ch                         | Test RAM between 512 and 640 kB                |
| 60h                         | Test extended memory                           |
| 62h                         | Test extended memory address lines             |
| 64h                         | Jump to UserPatch1                             |
| 66h                         | Configure advanced cache registers             |
| 67h                         | Initialize Multi Processor APIC                |
| 68h                         | Enable external and CPU caches                 |
| 69h                         | Setup System Management Mode (SMM) area        |
| 6Ah                         | Display external L2 cache size                 |
| 6Bh                         | Load custom defaults (optional)                |
| 6Ch                         | Display shadow-area message                    |
| 6Eh                         | Display possible high address for UMB recovery |
| 70h                         | Display error messages                         |
| 72h                         | Check for configuration errors                 |
| 76h                         | Check for keyboard errors                      |
| 7Ch                         | Set up hardware interrupt vectors              |
| 7Dh                         | Initialize Intelligent System Monitoring       |
| 7Eh                         | Initialize coprocessor if present              |
| 80h                         | Disable onboard Super I/O ports and IRQs       |
| 81h                         | Late POST device initialization                |
| 82h                         | Detect and install external RS232 ports        |
| 83h                         | Configure non-MCD IDE controllers              |
| 84h                         | Detect and install external parallel ports     |
| 85h                         | Initialize PC-compatible PnP ISA devices       |
| 86h                         | Re-initialize onboard I/O ports.               |

| <b>Terminal POST Errors</b> |  |
|-----------------------------|--|
| <b>Code</b>                 | <b>Description</b>   |
| 87h                         | Configure Motherboard Configurable Devices (optional)                      |
| 88h                         | Initialize BIOS Data Area  |
| 89h                         | Enable Non-Maskable Interrupts (NMIs)                                      |
| 8Ah                         | Initialize Extended BIOS Data Area   |
| 8Bh                         | Test and initialize PS/2 mouse   |
| 8Ch                         | Initialize floppy controller   |
| 8Fh                         | Determine number of ATA drives (optional)                                  |
| 90h                         | Initialize hard-disk controllers   |
| 91h                         | Initialize local-bus hard-disk controllers                                 |
| 92h                         | Jump to UserPatch2   |
| 93h                         | Build MPTABLE for multi-processor boards                                   |
| 95h                         | Install CD ROM for boot  |
| 96h                         | Clear huge ES segment register   |
| 98h                         | 1-2 Search for option ROMs. One long, two short beeps on check-sum failure |
| 99h                         | Check for SMART Drive (optional)   |
| 9Ah                         | Shadow option ROMs   |
| 9Ch                         | Set up Power Management  |
| 9Dh                         | Initialize security engine (optional)                                      |
| 9Eh                         | Enable hardware interrupts   |
| 9Fh                         | Determine number of ATA and SCSI drives                                    |
| A0h                         | Set time of day  |
| A2h                         | Check key lock   |
| A4h                         | Initialize typematic rate  |
| A8h                         | Erase F2 prompt  |
| AAh                         | Scan for F2 key stroke   |
| ACh                         | Enter SETUP  |
| AEh                         | Clear Boot flag  |
| B0h                         | Check for errors   |
| B1h                         | Inform RomPilot about the end of POST.                                     |

| <b>Terminal POST Errors</b> |   |
|-----------------------------|---|
| <b>Code</b>                 | <b>Description</b>  |
| B2h                         | POST done - prepare to boot operating system  |
| B4h                         | 1 One short beep before boot  |
| B5h                         | Terminate QuietBoot (optional)  |
| B6h                         | Check password (optional)   |
| B7h                         | Initialize ACPI BIOS  |
| B9h                         | Prepare Boot  |
| BAh                         | Initialize SMBIOS   |
| BBh                         | Initialize PnP Option ROMs  |
| BCh                         | Clear parity checkers   |
| BDh                         | Display MultiBoot menu  |
| BEh                         | Clear screen (optional)   |
| BFh                         | Check virus and backup reminders  |
| C0h                         | Try to boot with INT 19   |
| C1h                         | Initialize POST Error Manager (PEM)   |
| C2h                         | Initialize error logging  |
| C3h                         | Initialize error display function   |
| C4h                         | Initialize system error handler   |
| C5h                         | PnPnd dual CMOS (optional)  |
| C6h                         | Initialize note dock (optional)   |
| C7h                         | Initialize note dock late   |
| C8h                         | Force check (optional)  |
| C9h                         | Extended checksum (optional)  |
| CAh                         | Redirect Int 15h to enable remote keyboard  |
| CBh                         | Redirect Int 13h to Memory Technologies Devices such as ROM, RAM, PCMCIA, and serial disk |
| CCh                         | Redirect Int 10h to enable remote serial video  |
| CDh                         | Re-map I/O and memory for PCMCIA  |
| CEh                         | Initialize digitizer and display message  |
| D2h                         | Unknown interrupt   |
|                             |   |

| Terminal POST Errors |             |
|----------------------|-------------|
| Code                 | Description |
|                      |             |
|                      |             |
|                      |             |
|                      |             |
|                      |             |
|                      |             |

The following are for the boot block in Flash ROM:

| Boot Block Flash ROM Terminal POST Errors |                              |
|---|------------------------------|
| Code                                      | Description                  |
| E0h                                       | Initialize the chipset       |
| E1h                                       | Initialize the bridge        |
| E2h                                       | Initialize the CPU           |
| E3h                                       | Initialize system timer      |
| E4h                                       | Initialize system I/O        |
| E5h                                       | Check force recovery boot    |
| E6h                                       | Checksum BIOS ROM            |
| E7h                                       | Go to BIOS                   |
| E8h                                       | Set Huge Segment             |
| E9h                                       | Initialize Multi Processor   |
| EAh                                       | Initialize OEM special code  |
| EBh                                       | Initialize PIC and DMA       |
| ECh                                       | Initialize Memory type       |
| EDh                                       | Initialize Memory size       |
| EEh                                       | Shadow Boot Block            |
| EFh                                       | System memory test           |
| F0h                                       | Initialize interrupt vectors |
| F1h                                       | Initialize Run Time Clock    |
| F2h                                       | Initialize video             |

| <b>Boot Block Flash ROM Terminal POST Errors</b> |                                      |
|--|--------------------------------------|
| <b>Code</b>                                      | <b>Description</b>                   |
| F3h  | Initialize System Management Manager |
| F4h  | Output one beep                      |
| F5h  | Clear Huge Segment                   |
| F6h  | Boot to Mini DOS                     |
| F7h  | Boot to Full DOS                     |

If the BIOS detects error 2C, 2E, or 30 (base 512K RAM error), it displays an additional word-bitmap (xxxx) indicating the address line or bits that failed. For example, "2C 0002" means address line 1 (bit one set) has failed. "2E 1020" means data bits 12 and 5 (bits 12 and 5 set) have failed in the lower 16 bits. The BIOS also sends the bitmap to the port-80 LED display. It first displays the checkpoint code, followed by a delay, the high-order byte, another delay, and then the low order byte of the error. It repeats this sequence continuously.

## Appendix B

# Standardized Warning Statements for AC Systems

### About Standardized Warning Statements

The following statements are industry standard warnings, provided to warn the user of situations which have the potential for bodily injury. Should you have questions or experience difficulty, contact Supermicro's Technical Support department for assistance. Only certified technicians should attempt to install or configure components.

Read this appendix in its entirety before installing or configuring components in the Supermicro chassis.

These warnings may also be found on our website at [http://www.supermicro.com/about/policies/safety\\_information.cfm](http://www.supermicro.com/about/policies/safety_information.cfm).

### Warning Definition



**Warning!** This warning symbol means danger. You are in a situation that could cause bodily injury. Before you work on any equipment, be aware of the hazards involved with electrical circuitry and be familiar with standard practices for preventing accidents.

#### 警告の定義

この警告サインは危険を意味します。

人身事故につながる可能性がありますので、いずれの機器でも動作させる前に、電気回路に含まれる危険性に注意して、標準的な事故防止策に精通して下さい。

此警告符号代表危險。

您正处于可能受到严重伤害的工作环境中。在您使用设备开始工作之前，必须充分意识到触电的危险，并熟练掌握防止事故发生的标准工作程序。请根据每项警告结尾的声明号码找到此设备的安全性警告说明的翻译文本。

此警告符號代表危險。

您正處於可能身體可能會受損傷的工作環境中。在您使用任何設備之前，請注意觸電的危險，並且要熟悉預防事故發生的標準工作程序。請依照每一注意事項後的號碼找到相關的翻譯說明內容。

## Warnung

### WICHTIGE SICHERHEITSHINWEISE

Dieses Warnsymbol bedeutet Gefahr. Sie befinden sich in einer Situation, die zu Verletzungen führen kann. Machen Sie sich vor der Arbeit mit Geräten mit den Gefahren elektrischer Schaltungen und den üblichen Verfahren zur Vorbeugung vor Unfällen vertraut. Suchen Sie mit der am Ende jeder Warnung angegebenen Anweisungsnummer nach der jeweiligen Übersetzung in den übersetzten Sicherheitshinweisen, die zusammen mit diesem Gerät ausgeliefert wurden.

BEWAHREN SIE DIESE HINWEISE GUT AUF.

### INSTRUCCIONES IMPORTANTES DE SEGURIDAD

Este símbolo de aviso indica peligro. Existe riesgo para su integridad física. Antes de manipular cualquier equipo, considere los riesgos de la corriente eléctrica y familiarícese con los procedimientos estándar de prevención de accidentes. Al final de cada advertencia encontrará el número que le ayudará a encontrar el texto traducido en el apartado de traducciones que acompaña a este dispositivo.

GUARDE ESTAS INSTRUCCIONES.

### IMPORTANTES INFORMATIONS DE SÉCURITÉ

Ce symbole d'avertissement indique un danger. Vous vous trouvez dans une situation pouvant entraîner des blessures ou des dommages corporels. Avant de travailler sur un équipement, soyez conscient des dangers liés aux circuits électriques et familiarisez-vous avec les procédures couramment utilisées pour éviter les accidents. Pour prendre connaissance des traductions des avertissements figurant dans les consignes de sécurité traduites qui accompagnent cet appareil, référez-vous au numéro de l'instruction situé à la fin de chaque avertissement.

CONSERVEZ CES INFORMATIONS.

## תקנון הזהרות אזהרה

הזהרות הבאות הן אזהרות על פי תקני התעשייה, על מנת להזהיר את המשתמש מפני חבלה פיזית אפשרית. במידה ויש שאלות או היתקלות בבעיה כלשהי, יש ליצור קשר עם מחלקת תמיכה טכנית של סופרמיקרו. טכנאים מוסמכים בלבד רשאים להתקין או להגדיר את הרכיבים. יש לקרוא את הנספח במלואו לפני התקנת או הגדרת הרכיבים במארזי סופרמיקרו.

اَكْ ف حالة وُكِي اَي تتسبب ف اصابة جسدهُ هذا الزهز عُ خطر! تحذُرُ .  
قبل اَي تعول على اَي هعدات، كي على علن بالوخاطز ال اُجوة عي الذوائر  
الكهزبائِة  
وكي على دراةُ بالووارسات النقاائِة لو عُ وقع اَي حادث  
استخدم رِقن الب اِي الو صُص ف هاةُ كل تحذُرُ للعشر تزجوتها

안전을 위한 주의사항

경고!

이 경고 기호는 위험이 있음을 알려 줍니다. 작업자의 신체에 부상을 야기 할 수 있는 상태에 있게 됩니다. 모든 장비에 대한 작업을 수행하기 전에 전기회로와 관련된 위험요소들을 확인하시고 사전에 사고를 방지할 수 있도록 표준 작업절차를 준수해 주시기 바랍니다.

해당 번역문을 찾기 위해 각 경고의 마지막 부분에 제공된 경고문 번호를 참조하십시오

## BELANGRIJKE VEILIGHEIDSINSTRUCTIES

Dit waarschuwings symbool betekent gevaar. U verkeert in een situatie die lichamelijk letsel kan veroorzaken. Voordat u aan enige apparatuur gaat werken, dient u zich bewust te zijn van de bij een elektrische installatie betrokken risico's en dient u op de hoogte te zijn van de standaard procedures om ongelukken te voorkomen. Gebruik de nummers aan het eind van elke waarschuwing om deze te herleiden naar de desbetreffende locatie.

BEWAAR DEZE INSTRUCTIES

## Installation Instructions



**Warning!** Read the installation instructions before connecting the system to the power source.

### 設置手順書

システムを電源に接続する前に、設置手順書をお読み下さい。

### 警告

将此系统连接电源前,请先阅读安装说明。

### 警告

將系統與電源連接前，請先閱讀安裝說明。

Warnung

Vor dem Anschließen des Systems an die Stromquelle die Installationsanweisungen lesen.

¡Advertencia!

Lea las instrucciones de instalación antes de conectar el sistema a la red de alimentación.

Attention

Avant de brancher le système sur la source d'alimentation, consulter les directives d'installation.

יש לקרוא את הוראות התקנה לפני חיבור המערכת למקור מתח.

اقرأ إرشادات التركيب قبل توصيل النظام إلى مصدر للطاقة

시스템을 전원에 연결하기 전에 설치 안내를 읽어주십시오.

Waarschuwing

Raadpleeg de installatie-instructies voordat u het systeem op de voedingsbron aansluit.

## Circuit Breaker



**Warning!** This product relies on the building's installation for short-circuit (overcurrent) protection. Ensure that the protective device is rated not greater than: 250 V, 20 A.

### サーキット・ブレーカー

この製品は、短絡(過電流)保護装置がある建物での設置を前提としています。

保護装置の定格が250 V、20 Aを超えないことを確認下さい。

### 警告

此产品的短路(过载电流)保护由建筑物的供电系统提供,确保短路保护设备的额定电流不大于250V,20A。

### 警告

此產品的短路(過載電流)保護由建築物的供電系統提供,確保短路保護設備的額定電流不大於250V,20A。

### Warnung

Dieses Produkt ist darauf angewiesen, dass im Gebäude ein Kurzschluss- bzw. Überstromschutz installiert ist. Stellen Sie sicher, dass der Nennwert der Schutzvorrichtung nicht mehr als: 250 V, 20 A beträgt.

### ¡Advertencia!

Este equipo utiliza el sistema de protección contra cortocircuitos (o sobrecorrientes) del edificio. Asegúrese de que el dispositivo de protección no sea superior a: 250 V, 20 A.

### Attention

Pour ce qui est de la protection contre les courts-circuits (surtension), ce produit dépend de l'installation électrique du local. Vérifiez que le courant nominal du dispositif de protection n'est pas supérieur à :250 V, 20 A.

מוצר זה מסתמך על הגנה המותקנת במבנים למניעת קצר חשמלי. יש לוודא כי המכשיר המגן מפני הקצר החשמלי הוא לא יותר מ-250VDC, 20A

هذا المنتج يعتمد على معدات الحماية من الدوائر القصيرة التي تم تثبيتها في المبنى  
تأكد من أن تقييم الجهاز الوقائي ليس أكثر من : 20A, 250V

### 경고!

이 제품은 전원의 단락(과전류)방지에 대해서 전적으로 건물의 관련 설비에 의존합니다. 보호장치의 정격이 반드시 250V(볼트), 20A(암페어)를 초과하지 않도록 해야 합니다.

### Waarschuwing

Dit product is afhankelijk van de kortsluitbeveiliging (overspanning) van uw elektrische installatie. Controleer of het beveiligde apparaat niet groter gedimensioneerd is dan 250V, 20A.

## Power Disconnection Warning



**Warning!** The system must be disconnected from all sources of power and the power cord removed from the power supply module(s) before accessing the chassis interior to install or remove system components.



### 電源切断の警告

システムコンポーネントの取り付けまたは取り外しのために、シャーシ内部にアクセスするには、システムの電源はすべてのソースから切断され、電源コードは電源モジュールから取り外す必要があります。

### 警告

在你打开机箱并安装或移除内部器件前,必须将系统完全断电,并移除电源线。

### 警告

在您打開機殼安裝或移除內部元件前，必須將系統完全斷電，並移除電源線。

### Warnung

Das System muss von allen Quellen der Energie und vom Netzanschlusskabel getrennt sein, das von den Spg.Versorgungsteilmodulen entfernt wird, bevor es auf den Chassisinnenraum zurückgreift, um Systemsbestandteile anzubringen oder zu entfernen.

### ¡Advertencia!

El sistema debe ser disconnected de todas las fuentes de energía y del cable eléctrico quitado de los módulos de fuente de alimentación antes de tener acceso el interior del chasis para instalar o para quitar componentes de sistema.

### Attention

Le système doit être débranché de toutes les sources de puissance ainsi que de son cordon d'alimentation secteur avant d'accéder à l'intérieur du chasis pour installer ou enlever des composants de système.

אזהרה מפני ניתוק חשמלי

אזהרה!

יש לנתק את המערכת מכל מקורות החשמל ויש להסיר את כבל החשמלי מהספק לפני גישה לחלק הפנימי של המארז לצורך התקנת או הסרת רכיבים.

يجب فصل انظاؤ من جميع مصادر انطاقت وإزانت سهك انكهرباء من وحدة امداد انطاقت قيم

انصل إني امنطاقت انداخييت نههيكم ننتييح أو إزانت مكنناث الجهاز

경고!

시스템에 부품들을 장착하거나 제거하기 위해서는 새시 내부에 접근하기 전에 반드시 전원 공급장치로부터 연결되어있는 모든 전원과 전기코드를 분리해주어야 합니다.

Waarschuwing

Voordat u toegang neemt tot het binnenwerk van de behuizing voor het installeren of verwijderen van systeem onderdelen, dient u alle spanningsbronnen en alle stroomkabels aangesloten op de voeding(en) van de behuizing te verwijderen

## Equipment Installation



**Warning!** Only trained and qualified personnel should be allowed to install, replace, or service this equipment.

機器の設置

トレーニングを受け認定された人だけがこの装置の設置、交換、またはサービスを許可されていません。

警告

只有经过培训且具有资格的人员才能进行此设备的安装、更换和维修。

警告

只有經過受訓且具資格人員才可安裝、更換與維修此設備。

Warnung

Das Installieren, Ersetzen oder Bedienen dieser Ausrüstung sollte nur geschultem, qualifiziertem Personal gestattet werden.

¡Advertencia!

Solamente el personal calificado debe instalar, reemplazar o utilizar este equipo.

Attention

Il est vivement recommandé de confier l'installation, le remplacement et la maintenance de ces équipements à des personnels qualifiés et expérimentés.

אזהרה!

צוות מוסמך בלבד רשאי להתקין, להחליף את הציוד או לתת שירות עבור הציוד.

والمدربيه لتزكيب واستبدال أو خدمة هذا الجهاز يجب أن يسمح فقط للمظفيه المؤهليه

경고!

훈련을 받고 공인된 기술자만이 이 장비의 설치, 교체 또는 서비스를 수행할 수 있습니다.

Waarschuwing

Deze apparatuur mag alleen worden geïnstalleerd, vervangen of hersteld door geschoold en gekwalificeerd personeel.

## Restricted Area



**Warning!** This unit is intended for installation in restricted access areas. A restricted access area can be accessed only through the use of a special tool, lock and key, or other means of security. (This warning does not apply to workstations).

アクセス制限区域

このユニットは、アクセス制限区域に設置されることを想定しています。

アクセス制限区域は、特別なツール、鍵と錠前、その他のセキュリティの手段を用いてのみ出入りが可能です。

警告

此部件应安装在限制进出的场所，限制进出的场所指只能通过使用特殊工具、锁和钥匙或其它安全手段进出的场所。

警告

此装置仅限安装於進出管制區域，進出管制區域係指僅能以特殊工具、鎖頭及鑰匙或其他安全方式才能進入的區域。

### Warnung

Diese Einheit ist zur Installation in Bereichen mit beschränktem Zutritt vorgesehen. Der Zutritt zu derartigen Bereichen ist nur mit einem Spezialwerkzeug, Schloss und Schlüssel oder einer sonstigen Sicherheitsvorkehrung möglich.

### ¡Advertencia!

Esta unidad ha sido diseñada para instalación en áreas de acceso restringido. Sólo puede obtenerse acceso a una de estas áreas mediante la utilización de una herramienta especial, cerradura con llave u otro medio de seguridad.

### Attention

Cet appareil doit être installé dans des zones d'accès réservés. L'accès à une zone d'accès réservé n'est possible qu'en utilisant un outil spécial, un mécanisme de verrouillage et une clé, ou tout autre moyen de sécurité.

אזור עם גישה מוגבלת

אזהרה!

יש להתקין את היחידה באזורים שיש בהם הגבלת גישה. הגישה ניתנת בעזרת 'כלי אבטחה בלבד' (מפתח, מנעול וכד.).

تخصيص هذه التحذرة نترك بها ف مناطق محظورة تم .  
،ممكن اننصل إن منطقت محظورة فقط من خلال استخداو أداة خاصت  
أو أ وس هُت أخري نلالأمما ققم ومفتاح

### 경고!

이 장치는 접근이 제한된 구역에 설치하도록 되어있습니다. 특수도구, 잠금 장치 및 키, 또는 기타 보안 수단을 통해서만 접근 제한 구역에 들어갈 수 있습니다.

### Waarschuwing

Dit apparaat is bedoeld voor installatie in gebieden met een beperkte toegang. Toegang tot dergelijke gebieden kunnen alleen verkregen worden door gebruik te maken van speciaal gereedschap, slot en sleutel of andere veiligheidsmaatregelen.

## Battery Handling



**Warning!** There is the danger of explosion if the battery is replaced incorrectly. Replace the battery only with the same or equivalent type recommended by the manufacturer. Dispose of used batteries according to the manufacturer's instructions

### 電池の取り扱い

電池交換が正しく行われなかった場合、破裂の危険性があります。交換する電池はメーカーが推奨する型、または同等のものを使用下さい。使用済電池は製造元の指示に従って処分して下さい。

### 警告

電池更換不當會有爆炸危險。請只使用同類電池或制造商推荐的功能相当的電池更換原有電池。請按制造商的說明處理廢舊電池。

### 警告

電池更換不當會有爆炸危險。請使用製造商建議之相同或功能相當的電池更換原有電池。請按照製造商的說明指示處理廢棄舊電池。

### Warnung

Bei Einsetzen einer falschen Batterie besteht Explosionsgefahr. Ersetzen Sie die Batterie nur durch den gleichen oder vom Hersteller empfohlenen Batterietyp. Entsorgen Sie die benutzten Batterien nach den Anweisungen des Herstellers.

### Attention

Danger d'explosion si la pile n'est pas remplacée correctement. Ne la remplacer que par une pile de type semblable ou équivalent, recommandée par le fabricant. Jeter les piles usagées conformément aux instructions du fabricant.

### ¡Advertencia!

Existe peligro de explosión si la batería se reemplaza de manera incorrecta. Reemplazar la batería exclusivamente con el mismo tipo o el equivalente recomendado por el fabricante. Desechar las baterías gastadas según las instrucciones del fabricante.

אזהרה!

קיימת סכנת פיצוץ של הסוללה במידה והוחלפה בדרך לא תקינה. יש להחליף את הסוללה בסוג התואם מחברת יצרן מומלצת. סילוק הסוללות המשומשות יש לבצע לפי הוראות היצרן.

هناك خطر من انفجار في حالة اسبدال البطارية بطريقة غير صحيحة فعلى  
اسبدال البطارية  
فقط بنفس النوع أو ما يعادلها مما أوصت به الشركة المصنعة  
جخلص من البطاريات المسحومة وفقا لعمليات الشركة الصانعة

경고!

배터리가 올바르게 교체되지 않으면 폭발의 위험이 있습니다. 기존 배터리와 동일하거나 제조사에서 권장하는 동등한 종류의 배터리로만 교체해야 합니다. 제조사의 안내에 따라 사용된 배터리를 처리하여 주십시오.

Waarschuwing

Er is ontplofingsgevaar indien de batterij verkeerd vervangen wordt. Vervang de batterij slechts met hetzelfde of een equivalent type die door de fabrikant aanbevolen wordt. Gebruikte batterijen dienen overeenkomstig fabrieksvoorschriften afgevoerd te worden.

## Redundant Power Supplies



**Warning!** This unit might have more than one power supply connection. All connections must be removed to de-energize the unit.

冗長電源装置

このユニットは複数の電源装置が接続されている場合があります。

ユニットの電源を切るためには、すべての接続を取り外さなければなりません。

警告

此部件连接的电源可能不止一个，必须将所有电源断开才能停止给该部件供电。

警告

此装置连接的电源可能不只一个，必须切断所有电源才能停止对该装置的供电。

Warnung

Dieses Gerät kann mehr als eine Stromzufuhr haben. Um sicherzustellen, dass der Einheit kein Strom zugeführt wird, müssen alle Verbindungen entfernt werden.

¡Advertencia!

Puede que esta unidad tenga más de una conexión para fuentes de alimentación. Para cortar por completo el suministro de energía, deben desconectarse todas las conexiones.

Attention

Cette unité peut avoir plus d'une connexion d'alimentation. Pour supprimer toute tension et tout courant électrique de l'unité, toutes les connexions d'alimentation doivent être débranchées.

אם קיים יותר מספק אחד

אזהרה!

ליחידה יש יותר מחיבור אחד של ספק. יש להסיר את כל החיבורים על מנת לרוקן את היחידה.

قد يكون لهذا الجهاز عدة اتصالات بوحدات امداد الطاقة .  
يجب إزالة كافة الاتصالات لعسل الوحدة عن الكهرباء

경고!

이 장치에는 한 개 이상의 전원 공급 단자가 연결되어 있을 수 있습니다. 이 장치에 전원을 차단하기 위해서는 모든 연결 단자를 제거해야만 합니다.

Waarschuwing

Deze eenheid kan meer dan één stroomtoevoeraansluiting bevatten. Alle aansluitingen dienen verwijderd te worden om het apparaat stroomloos te maken.

## Backplane Voltage



**Warning!** Hazardous voltage or energy is present on the backplane when the system is operating. Use caution when servicing.

### バックプレーンの電圧

システムの稼働中は危険な電圧または電力が、バックプレーン上にかかっています。

修理する際には注意ください。

### 警告

当システム正在进行时，背板上有很危险的电压或能量，进行维修时务必小心。

### 警告

當系統正在進行時，背板上危險的電壓或能量，進行維修時務必小心。

### Warnung

Wenn das System in Betrieb ist, treten auf der Rückwandplatine gefährliche Spannungen oder Energien auf. Vorsicht bei der Wartung.

### ¡Advertencia!

Cuando el sistema está en funcionamiento, el voltaje del plano trasero es peligroso. Tenga cuidado cuando lo revise.

### Attention

Lorsque le système est en fonctionnement, des tensions électriques circulent sur le fond de panier. Prendre des précautions lors de la maintenance.

מתח בפנל האחורי

אזהרה!

קיימת סכנת מתח בפנל האחורי בזמן תפעול המערכת. יש להיזהר במהלך העבודה.

هناك خطر من التيار الكهربائي أو الطاقة المتجددة على اللوحة  
عندما يكون النظام يعمل كه حذرا عند خدمة هذا الجهاز

경고!

시스템이 동작 중일 때 후면판 (Backplane)에는 위험한 전압이나 에너지가 발생 합니다.  
서비스 작업 시 주의하십시오.

Waarschuwing

Een gevaarlijke spanning of energie is aanwezig op de backplane wanneer het systeem in gebruik is. Voorzichtigheid is geboden tijdens het onderhoud.

## Comply with Local and National Electrical Codes



**Warning!** Installation of the equipment must comply with local and national electrical codes.

地方および国の電気規格に準拠

機器の取り付けはその地方および国の電気規格に準拠する必要があります。

警告

设备安装必须符合本地与本国电气法规。

警告

設備安裝必須符合本地與本國電氣法規。

Warnung

Die Installation der Geräte muss den Sicherheitsstandards entsprechen.

¡Advertencia!

La instalación del equipo debe cumplir con las normas de electricidad locales y nacionales.

Attention

L'équipement doit être installé conformément aux normes électriques nationales et locales.

תיאום חוקי החשמל הארצי  
אזהרה!

התקנת הציוד חייבת להיות תואמת לחוקי החשמל המקומיים והארציים.

تركيب المعدات الكهربائية يجب أن يمتثل للقوايه المحلية والبطية المتعلقة  
بالكهرباء

경고!

현 지역 및 국가의 전기 규정에 따라 장비를 설치해야 합니다.

Waarschuwing

Bij installatie van de apparatuur moet worden voldaan aan de lokale en nationale elektriciteitsvoorschriften.

## Product Disposal



**Warning!** Ultimate disposal of this product should be handled according to all national laws and regulations.

製品の廃棄

この製品を廃棄処分する場合、国の関係する全ての法律・条例に従い処理する必要があります。

警告

本产品的废弃处理应根据所有国家的法律和规章进行。

警告

本產品的廢棄處理應根據所有國家的法律和規章進行。

Warnung

Die Entsorgung dieses Produkts sollte gemäß allen Bestimmungen und Gesetzen des Landes erfolgen.

¡Advertencia!

Al deshacerse por completo de este producto debe seguir todas las leyes y reglamentos nacionales.

## Attention

La mise au rebut ou le recyclage de ce produit sont généralement soumis à des lois et/ou directives de respect de l'environnement. Renseignez-vous auprès de l'organisme compétent.

סילוק המוצר

אזהרה!

סילוק סופי של מוצר זה חייב להיות בהתאם להנחיות וחוקי המדינה.

التخلص النهائي من هذا المنتج ينبغي التعامل معه وفقا لجميع القوانين واللوائح الوطنية عند

## 경고!

이 제품은 해당 국가의 관련 법규 및 규정에 따라 폐기되어야 합니다.

## Waarschuwing

De uiteindelijke verwijdering van dit product dient te geschieden in overeenstemming met alle nationale wetten en reglementen.

## Hot Swap Fan Warning



**Warning!** Hazardous moving parts. Keep away from moving fan blades. The fans might still be turning when you remove the fan assembly from the chassis. Keep fingers, screwdrivers, and other objects away from the openings in the fan assembly's housing.

## ファン・ホットスワップの警告

警告!回転部品に注意。運転中は回転部(羽根)に触れないでください。シャーシから冷却ファン装置を取り外した際、ファンがまだ回転している可能性があります。ファンの開口部に、指、ドライバー、およびその他のものを近づけないで下さい。

## 警告!

警告! 危險的可移動性零件。請務必與轉動的风扇叶片保持距離。當您從機架移除風扇裝置，風扇可能仍在轉動。小心不要將手指、螺絲起子和其他物品太靠近風扇

## 警告

危險的可移動性零件。請務必與轉動的风扇叶片保持距離。當您從機架移除風扇裝置，風扇可能仍在轉動。小心不要將手指、螺絲起子和其他物品太靠近風扇。

### Warnung

Gefährlich Bewegende Teile. Von den bewegenden Lüfterblätter fern halten. Die Lüfter drehen sich u. U. noch, wenn die Lüfterbaugruppe aus dem Chassis genommen wird. Halten Sie Finger, Schraubendreher und andere Gegenstände von den Öffnungen des Lüftergehäuses entfernt.

### ¡Advertencia!

Riesgo de piezas móviles. Mantener alejado de las aspas del ventilador. Los ventiladores podran dar vuelta cuando usted quite el montaje del ventilador del chasis. Mantenga los dedos, los destornilladores y todos los objetos lejos de las aberturas del ventilador

### Attention

Pieces mobiles dangereuses. Se tenir a l'écart des lames du ventilateur Il est possible que les ventilateurs soient toujours en rotation lorsque vous retirerez le bloc ventilateur du châssis. Prenez garde à ce que doigts, tournevis et autres objets soient éloignés du logement du bloc ventilateur.

### אזהרה!

חלקים נעים מסוכנים. התרחק מלהבי המאוורר בפעולה כאשר מסירים את חלקי המאוורר מהמארז, יתכן והמאווררים עדיין עובדים. יש להרחיק למרחק בטוח את האצבעות וכלי עבודה שונים מהפתחים בתוך המאוורר

تحذير! أجزاء متحركة خطيرة. ابتعد عن شفرات المروحة المتحركة. من الممكن أن المراوح لا تزال تدور عند إزالة كتلة المروحة من الهيكل يجب إبقاء الأصابع ومفكات البراغي وغيرها من الأشياء بعيدا عن الفتحات في كتلة المروحة

### 경고!

움직이는 위험한 부품. 회전하는 송풍 날개에 접근하지 마세요. 새시로부터 팬 조립품을 제거할 때 팬은 여전히 회전하고 있을 수 있습니다. 팬 조립품 외관의 열려있는 부분들로부터 손가락 및 스크류드라이버, 다른 물체들이 가까이 하지 않도록 배치해 주십시오.

### Waarschuwing

Gevaarlijk bewegende onderdelen. Houd voldoende afstand tot de bewegende ventilatorbladen. Het is mogelijk dat de ventilator nog draait tijdens het verwijderen van het ventilatorsamenstel uit het chassis. Houd uw vingers, schroevendraaiers en eventuele andere voorwerpen uit de buurt van de openingen in de ventilatorbehuizing.

## Power Cable and AC Adapter



**Warning!** When installing the product, use the provided or designated connection cables, power cables and AC adaptors. Using any other cables and adaptors could cause a malfunction or a fire. Electrical Appliance and Material Safety Law prohibits the use of UL or CSA -certified cables (that have UL/CSA shown on the cord) for any other electrical devices than products designated by Supermicro only.

### 電源コードとACアダプター

製品を設置する場合、提供または指定および購入された接続ケーブル、電源コードとACアダプターを、該当する地域の条例や安全基準に適合するコードサイズやプラグと共に使用下さい。他のケーブルやアダプタを使用すると故障や火災の原因になることがあります。

電気用品安全法は、ULまたはCSA認定のケーブル(UL/CSAマークがコードに表記)を Supermicro が指定する製品以外に使用することを禁止しています。

### 警告

安装此产品时,请使用本身提供的或指定的或采购的连接线,电源线和电源适配器。包含遵照当地法规和安全要求的合规的电源线尺寸和插头。使用其它线材或适配器可能会引起故障或火灾。除了Supermicro所指定的产品,电气用品和材料安全法律规定禁止使用未经UL或CSA认证的线材。(线材上会显示UL/CSA符号)。

### 警告

安裝此產品時,請使用本身提供的或指定的或採購的連接線,電源線和電源適配器。包含遵照當地法規和安全要求的合規的電源線尺寸和插頭。使用其它線材或適配器可能會引起故障或火災。除了Supermicro所指定的產品,電氣用品和材料安全法律規定禁止使用未經UL或CSA認證的線材。(線材上會顯示UL/CSA符號)。

### Warnung

Nutzen Sie beim Installieren des Produkts ausschließlich die von uns zur Verfügung gestellten Verbindungskabeln, Stromkabeln und/oder Adapter, die Ihre örtlichen Sicherheitsstandards einhalten. Der Gebrauch von anderen Kabeln und Adapter können Fehlfunktionen oder Feuer verursachen. Die Richtlinien untersagen das Nutzen von UL oder CAS zertifizierten Kabeln (mit UL/CSA gekennzeichnet), an Geräten oder Produkten die nicht mit Supermicro gekennzeichnet sind.

### ¡Advertencia!

Cuando instale el producto, utilice la conexión provista o designada o procure cables, Cables de alimentación y adaptadores de CA que cumplan con los códigos locales y los requisitos de seguridad, incluyendo el tamaño adecuado del cable y el enchufe. El uso de otros cables y adaptadores podría causar un mal funcionamiento o un incendio. La Ley de Seguridad de Aparatos Eléctricos y de Materiales prohíbe El uso de cables certificados por UL o CSA (que tienen el certificado UL / CSA en el código) para cualquier otros dispositivos eléctricos que los productos designados únicamente por Supermicro.

### Attention

Lors de l'installation du produit, utilisez les cables de connection fournis ou désigné ou achetez des cables, cables de puissance et adaptateurs respectant les normes locales et les conditions de securite y compris les tailles de cables et les prises electriques appropries. L'utilisation d'autres cables et adaptateurs peut provoquer un dysfonctionnement ou un incendie. Appareils électroménagers et la Loi sur la Sécurité Matériel interdit l'utilisation de câbles certifiés- UL ou CSA (qui ont UL ou CSA indiqué sur le code) pour tous les autres appareils électriques sauf les produits désignés par Supermicro seulement.

AC ימאתמו מיילמשח מילבכ

!הרהזא

ךרוצל ומאתוה וא ושכרנ רשא AC מימאתמו מיקפס, מילבכב שמתשהל שי, רצומה תא מיניקתמ רשאכ לכב שומיש . עקתהו לבכה לש הנוכח הדימ ללוכ, תוימוקמה תוחיטבה תושירדל ומאתוה רשאו, הנקתהה למשחה ירישכמב שומישה יקוחל מאתהב. ילמשח רצק וא הלקתל מורגל לולע, רחא גוסמ מאתמ וא לבכ לש דוק מהילע עיפומ רשאכ) UL-ב או CSA-ב-ב מיכמסומה מילבכב שמתשהל רוסיא מייק, תוחיטבה יקוחו דבלב Supermicro י"ע מאתוה רשא רצומב קר אלא, רחא ילמשח רצומ לכ רובע (UL/CSA)

תאלבאלא אארשב מץ וא אדדחמלא וא ארפוטמלא תאליטוטלא מאדחטסאב מץ, אגתנמלא בייקרת דנע לכלז יפ אמב אילחמלא אמאלסלא תאבלטתמו נינאוץב מאזתלאלא אמ דדרתמלא ראיטלא תאלוחמו אילברמלא קיירח וא לטע יפ בבסטטי דץ ירשא תאלוחמו תאלבאלא יא מאדחטסא. מילסלא סבאלאו לטומוא מץח CSA וא UL לביק נמ אדמתמלא תאלבאלא מאדחטסא תאדעמלא אילברמלא אזהאלל אמאלסלא נונאק רזחיי Supermicro לביק נמ אדדחמלא אילחמלא תאגתנמלא רייג ירשא תאדעמ יא אמ (UL/CSA) אמאלע למחתיטלאו

### 전원 케이블 및 AC 어댑터

경고! 제품을 설치할 때 현지 코드 및 적절한 굵기의 코드와 플러그를 포함한 안전 요구 사항을 준수하여 제공되거나 지정된 연결 혹은 구매 케이블, 전원 케이블 및 AC 어댑터를 사용하십시오.

다른 케이블이나 어댑터를 사용하면 오작동이나 화재가 발생할 수 있습니다. 전기 용품 안전법은 UL 또는 CSA 인증 케이블 (코드에 UL / CSA가 표시된 케이블)을 Supermicro 가 지정한 제품 이외의 전기 장치에 사용하는 것을 금지합니다.

### Stroomkabel en AC-Adapter

Waarschuwing! Bij het aansluiten van het Product uitsluitend gebruik maken van de geleverde Kabels of een andere geschikte aan te schaffen Aansluitmethode, deze moet altijd voldoen aan de lokale voorschriften en veiligheidsnormen, inclusief de juiste kabeldikte en stekker. Het gebruik van niet geschikte Kabels en/of Adapters kan een storing of brand veroorzaken. Wetgeving voor Elektrische apparatuur en Materiaalveiligheid verbied het gebruik van UL of CSA -gecertificeerde Kabels (met UL/CSA in de code) voor elke andere toepassing dan de door Supermicro hiervoor beoogde Producten.

# Appendix C

## Specifications and Compliance

**Processors**

AMD EPYC 7002 Series in a SP3 type socket

**Chipset**

System on Chip

**Memory**

Eight slots for up to 2 TB of 3DS RDIMM/LRDIMM), with speeds of up to 3200 MHz; support for Non-Volatile DIMM (NVDIMM)

**BIOS**

128 Mb SPI AMI BIOS SM Flash UEFI BIOS

**Motherboard**

BH12SSI-M25

**Chassis**

na; (WxHxD) 4.64 x 1.2 x 23.2 in. (125.5 x 30.5 x 589 mm)

**Storage Drives**

Two hot-swap 2.5" U.2 (stack up) hybrid bays for:

SBA-4119S-T2N, SATA or NVMe with add-on module

SBA-4119S-C2N, SAS or NVMe with add-on module

M.2: Up to two PCI-E 4.0 NVMe or SATA

**Operating Environment**

Operating Temperature: 10° to 35° C (50° to 95° F)

Non-operating Temperature: -40° to 70° C (-40° to 158° F)

Operating Relative Humidity: 8% to 90% (non-condensing)

Non-operating Relative Humidity: 5% to 95% (non-condensing)

## Regulatory Compliance

FCC, ICES, CE, VCCI, RCM, NRTL, CB

## Applied Directives, Standards

EMC/EMI: 2014/30/EU (EMC Directive)

FCC Part 15

ICES-003

VCCI 32-1

AS/NZS CISPR 32

EN55032

EN55035

CISPR 24

EN 61000-3-2

EN 61000-3-3

EN 61000-4-2

EN 61000-4-3

EN 61000-4-4

EN 61000-4-5

EN 61000-4-6

EN 61000-4-8

EN 61000-4-11

Green Environment:

2011/65/EU (RoHS Directive)

EC 1907/2006 (REACH)

2012/19/EU (WEEE Directive)

Product Safety: 2014/35/EU (LVD Directive)

## Perchlorate Warning

California Best Management Practices Regulations for Perchlorate Materials: This Perchlorate warning applies only to products containing CR (Manganese Dioxide) Lithium coin cells. "Perchlorate Material-special handling may apply. See [www.dtsc.ca.gov/hazardouswaste/perchlorate](http://www.dtsc.ca.gov/hazardouswaste/perchlorate)"

この装置は、クラスA機器です。この装置を住宅環境で使用すると電波妨害を引き起こすことがあります。この場合には使用者が適切な対策を講ずるよう要求されることがあります。

VCCI — A

## General Data Center Environmental Specifications

Particulate contamination specifications

Air filtration: Data centers must be kept clean to Class 8 of ISO 14644-1 (ISO 2015). The air entering the data center should be filtered with a MERV 11 filter or better. The air within the data center should be continuously filtered with a MERV 8 filter or better.

Conductive dust: Air should be free of conductive dust, zinc whiskers, or other conductive particles.

Corrosive dust: Air should be free of corrosive dust.

Gaseous\* contamination specifications

Copper coupon corrosion rate: <300 Å/month per class G1 as defined by ANSI/ISA71.04-2013, reference by ASHRAE TC 9.9

Silver coupon corrosion rate: <200 Å/month per class G1 as defined by ANSI/ISA71.04-2013, reference by ASHRAE TC 9.9

\*If testing with silver or copper coupons results in values less than 200 Å/month or 300 Å/month, respectively, then operating up to 70% relative humidity (RH) is acceptable. If the testing shows corrosion levels exceed these limits, then catalyst-type pollutants are probably present and RH should be driven to 50% or lower.