

## SFP-10GB-DW-C-BXD-20-AO

MSA and TAA 10G-BX DWDM 100GHz Multi-rate Multi-band SFP+ Transceiver (SMF, 20km, Primary, DOM)

### Features

- Hot-pluggable SFP+ footprint
- Must be paired with a secondary, upstream transceiver
- Supports 1.2 to 11.3 Gb/s
- Monolithic Tunable BOSA
- Limiting electrical interface receiver
- Single 3.3V Power Supply
- 40 dual-band bidirectional Point-to- Point links in 100GHz ITU grids
- Single LC connector for Bi-directional
- Features auto-tuning technology
- Built-in digital diagnostic functions
- Operating Temperature: -5C to 70C
- RoHS-6 compliant and Lead Free



### Applications

- 8x/10x Fibre Channel
- 10x Gigabit Ethernet over DWDM
- Access, Metro and Enterprise

### Product Description

This MSA Compliant SFP+ transceiver provides 10GBase-DWDM throughput up to 20km over single-mode fiber (SMF) using a tunable wavelength via an LC connector. It is built to MSA standards and is uniquely serialized and data-traffic and application tested to ensure that they will integrate into your network seamlessly. Digital optical monitoring (DOM) support is also present to allow access to real-time operating parameters. This transceiver is Trade Agreements Act (TAA) compliant. We stand behind the quality of our products and proudly offer a limited lifetime warranty.

AddOn's transceivers are RoHS compliant and lead-free.

TAA refers to the Trade Agreements Act (19 U.S.C. & 2501-2581), which is intended to foster fair and open international trade. TAA requires that the U.S. Government may acquire only "U.S. – made or designated country end products."



## Regulatory Compliance

- ESD to the Electrical PINs: compatible with MIL-STD-883E Method 3015.4
- ESD to the LC Receptacle: compatible with IEC 61000-4-3
- EMI/EMC compatible with FCC Part 15 Subpart B Rules, EN55022:2010
- Laser Eye Safety compatible with FDA 21CFR, EN60950-1& EN (IEC) 60825-1,2
- RoHS compliant with EU RoHS 2.0 directive 2015/863/EU

## Wavelength Guide (100GHz ITU-T Channel)

No	ITU Grids (GHz)	Downstream (GHz)	Upstream (GHz)	No	ITU Grids (GHz)	Downstream (GHz)	Upstream (GHz)
1	192,100	192,080	192,120	21	194,100	194,080	194,120
2	192,200	192,180	192,220	22	194,200	194,180	194,220
3	192,300	192,280	192,320	23	194,300	194,280	194,320
4	192,400	192,380	192,420	24	194,400	194,380	194,420
5	192,500	192,480	192,520	25	194,500	194,480	194,520
6	192,600	192,580	192,620	26	194,600	194,580	194,620
7	192,700	192,680	192,720	27	194,700	194,680	194,720
8	192,800	192,780	192,820	28	194,800	194,780	194,820
9	192,900	192,880	192,920	29	194,900	194,880	194,920
10	193,000	192,980	193,020	30	195,000	194,980	195,020
11	193,100	193,080	193,120	31	195,100	195,080	195,120
12	193,200	193,180	193,220	32	195,200	195,180	195,220
13	193,300	193,280	193,320	33	195,300	195,280	195,320
14	193,400	193,380	193,420	34	195,400	195,380	195,420
15	193,500	193,480	193,520	35	195,500	195,480	195,520
16	193,600	193,580	193,620	36	195,600	195,580	195,620
17	193,700	193,680	193,720	37	195,700	195,680	195,720
18	193,800	193,780	193,820	38	195,800	195,780	195,820
19	193,900	193,880	193,920	39	195,900	195,880	195,920
20	194,000	193,980	194,020	40	196,000	195,980	196,020

## Absolute Maximum Ratings

Parameter	Symbol	Min.	Typ.	Max.	Unit	Notes
Maximum Supply Voltage	Vcc	-0.5		4.0	V	
Storage Temperature	TS	-40		85	°C	
Operating Case Temperature	Tc	-5		70	°C	
Relative Humidity	RH	0		85	%	1
Receiver Optical Damage Threshold	RxDamage	3			dBm	
Bit Rate	BR	1.2		11.3125	Gb/s	2
Max. Supported Link Length	LMAX			20	km	3

**Notes:**

1. Non-condensing
2. The product can support data rates up to 11.3 Gb/s, but we only test at 10.3 Gb/s with a  $2^{31} - 1$  PRBS pattern at the BER defined in Timing Parameters.
3. Over G.652 single mode fiber.

**Electrical Characteristics (over Top)**

Parameter	Symbol	Min.	Typ.	Max.	Unit	Notes
Supply Voltage	V <sub>CC</sub>	3.14		3.46		
Supply Current	I <sub>CC</sub>			796	mA	1
Module total power dissipation	P			2.5	W	2
<b>Transmitter</b>						
Input differential impedance	R <sub>in</sub>	80	100	120	Ω	
Differential data input swing	V <sub>in,pp</sub>	200		850	mV	3
Transmit Disable Voltage	V <sub>D</sub>	V <sub>CC</sub> -0.8		V <sub>CC</sub>	V	
Transmit Enable Voltage	V <sub>EN</sub>	V <sub>EE</sub>		V <sub>EE</sub> +0.8	V	
<b>Receiver</b>						
Output differential impedance	R <sub>out</sub>	80	100	120	Ω	
Differential data output swing	V <sub>out,pp</sub>	300		850	mV	4
Output rise time and fall time	T <sub>r</sub> , T <sub>f</sub>	28			ps	4, 5
LOS asserted	V <sub>LOS_A</sub>	V <sub>CC</sub> -0.8		V <sub>CC</sub>	V	
LOS de-asserted	V <sub>LOS_D</sub>	V <sub>EE</sub>		V <sub>EE</sub> +0.8	V	
Power Supply Noise Tolerance	V <sub>CC</sub> T/V <sub>CC</sub> R	Per SFF-8431 Rev 4.1			mV <sub>pp</sub>	

**Notes:**

1. Compliant with the SFP+ Module Power Supply Requirements defined in [1], Tab. 8.
2. Maximum total power value is specified across the full operating temperature and voltage range.
3. Connected directly to TX data input pins.
4. Into 100Ω differential termination.
5. 20 – 80%. Measured with Module Compliance Test Board and OMA test pattern. Use of four 1's and four 0's sequence in the PRBS 9 is an acceptable alternative. SFF-8431 Rev 4.1.

**Optical Characteristics (over T<sub>OP</sub>, VCC = 3.14 to 3.46 Volts)**

Parameter	Symbol	Min.	Typ.	Max.	Unit	Notes	
<b>Transmitter</b>							
Average Launch Power	PAVE	0.5			dBm		
Nominal Optical Central Wavelength	$\lambda_c$	1529.55		1565.50	nm	2	
Nominal Optical Central Frequency	$f_c$	192.1		196.0	THz	2	
Downstream channels (west to east)	$f_{c\_east}$	192.08		195.98	THz	2,3	
Wavelength tuning channel to channel	T <sub>TUNE</sub>		1		s	7	
Optical Return Loss Tolerance	RL	24			dB		
Side-Mode Suppression Ratio	SMSR	30			dB		
Optical Extinction Ratio	ER	9.0	9.5		dB		
Ave. Launch power when Tx is OFF	POFF			-30	dBm		
Tx Jitter	T <sub>xj1</sub>	Per 802.3ae requirements					
Relative Intensity Noise	RIN			-128	dB/Hz		
Center Wavelength	$\lambda_{c\_EOL}$	z-5	z	z+5	GHz		
<b>Receiver at 360ps/nm over 20km</b>							
Bit rate	BER						
9.83 Gb/s	<1E-12	RSENS1		-18.5	dBm	4,5	
10.3 Gb/s	<1E-12	RSENS2		-18.5	dBm	4,5	
Overload (Average Power)	PAVE			-7	dBm		
Optical Center Wavelength	$\lambda_C$	1527		1569	nm	6	
LOS De-Assert	LOSD			-19.5	dBm		
LOS Assert	LOSA	-34		-20.0	dBm		
LOS Hysteresis	LOSH	0.5			dB		
Receiver Reflectance	R <sub>rx</sub>			-27	dB		

**Notes:**

1. The wavelength and output power are expected to be detected by external wavelength and/or power monitor device during power leveling, and feedback, if needed, is expected to be provided through communication channel.
2. As per ITU-T 694.1, 40 channel 100GHz spacing.
3. The East and West channels are located off-grid to 100GHz ITU grids by the typical value specified here.
4. Measured with ER=9.5dB; BER<10<sup>-12</sup>; 2<sup>31</sup> – 1 PRBS. Including ~0.5dB penalty for crosstalk of Tx to Rx and penalty from Out of Band channel T<sup>2</sup>DOC.
5. For 10GE application, -18.5 dBm is equivalent to an OMA of -16.5 dBm at 9.5dB ER.
6. Measured at 1527-1569 nm with worst ER; PRBS31.
7. Tuning time required to actively change wavelength of the local transceiver (while not using auto-tuning).

## Timing Parameters

Parameter	Symbol	Min.	Max.	Unit	Notes
Time to initialize cooled module	t_start_up_cooled		90	s	1

### Notes:

1. Excludes cold start time, which can take between 5-12 minutes.

## Pin Descriptions

Pin	Symbol	Name/Descriptions	Ref.
1	VEET	Transmitter Ground	1
2	TFAULT	Transmitter Fault	2
3	TDIS	Transmitter Disable. Laser output disabled on high or open.	3
4	SDA	2-wire Serial Interface Data Line	2
5	SCL	2-wire Serial Interface Clock Line	2
6	MOD_ABS	Module Absent. Grounded within the module	2
7	NA	Not Used	
8	RX_LOS	Loss of Signal indication. Logic 0 indicates normal operation.	4
9	NA	No Used	
10	VEER	Receiver Ground	1
11	VEER	Receiver Ground	1
12	RD-	Receiver Inverted DATA out. AC Coupled.	
13	RD+	Receiver Non-inverted DATA out. AC Coupled.	
14	VEER	Receiver Ground	1
15	VCCR	Receiver Power Supply	5
16	VCCT	Transmitter Power Supply	5
17	VEET	Transmitter Ground	1
18	TD+	Transmitter Non-Inverted DATA in. AC Coupled.	
19	TD-	Transmitter Inverted DATA in. AC Coupled.	
20	VEET	Transmitter Ground	1

### Notes:

1. Circuit ground is internally isolated from chassis ground.
2. T<sub>FAULT</sub> is an open collector/drain output, which should be pulled up with a 4.7k – 10k Ohms resistor on the host board if intended for use. Pull up voltage should be between 2.0V to V<sub>cc</sub> + 0.3V. A high output indicates a transmitter fault caused by either the TX bias current or the TX output power exceeding the preset alarm thresholds. A low output indicates normal operation. In the low state, the output is pulled

to <0.8V.

3. Laser output disabled on  $T_{DIS} > 2.0V$  or open, enabled on  $T_{DIS} < 0.8V$ .
4. LOS is open collector output. Should be pulled up with  $4.7k - 10k\Omega$  on host board to a voltage between 2.0V and 3.6V. Logic 0 indicates normal operation; logic 1 indicates loss of signal.
5. Internally connected

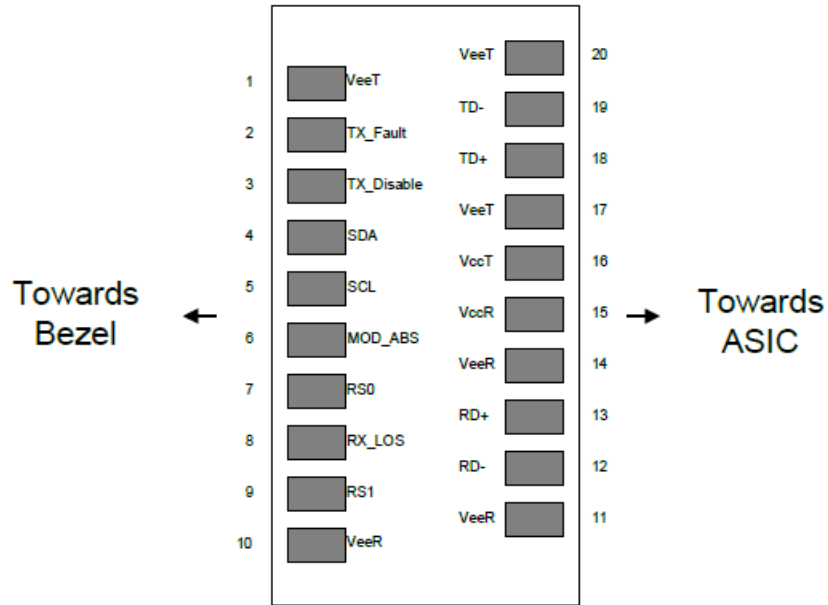

Pin-out of connector Block on Host board

### Digital Diagnostic Specifications

Parameter	Symbol	Min.	Max.	Unit	Accuracy	Notes
Transceiver temperature	$\Delta$ DDTemp	-20	+85	°C	±5°C	1
Transceiver supply voltage	$\Delta$ DDVoltage	2.8	4.0	V	±3%	
Transmitter bias current	$\Delta$ DDBias	0	127	mA	±10%	2
Transmitter output power	$\Delta$ DDTx-Power	-1	+5	dBm	±2dB	
Receiver average optical input power	$\Delta$ DDRx-Power	-22	-7	dBm	±2dB	

### Notes:

1. Typical value measured at internally measured location.
2. The accuracy of the Tx bias current is 10% of the actual current from the laser driver to the laser

### Start-Up Sequence

The modules adhere to MSA SFF-8690 for wavelength / channel selection of these tunable modules. The module behavior is described in the flowchart below:

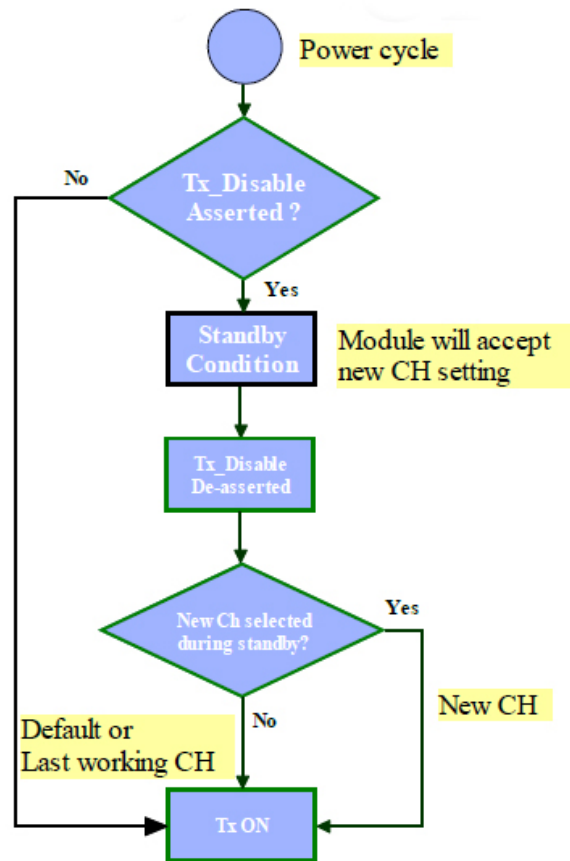

# Host-Module Interface Diagram

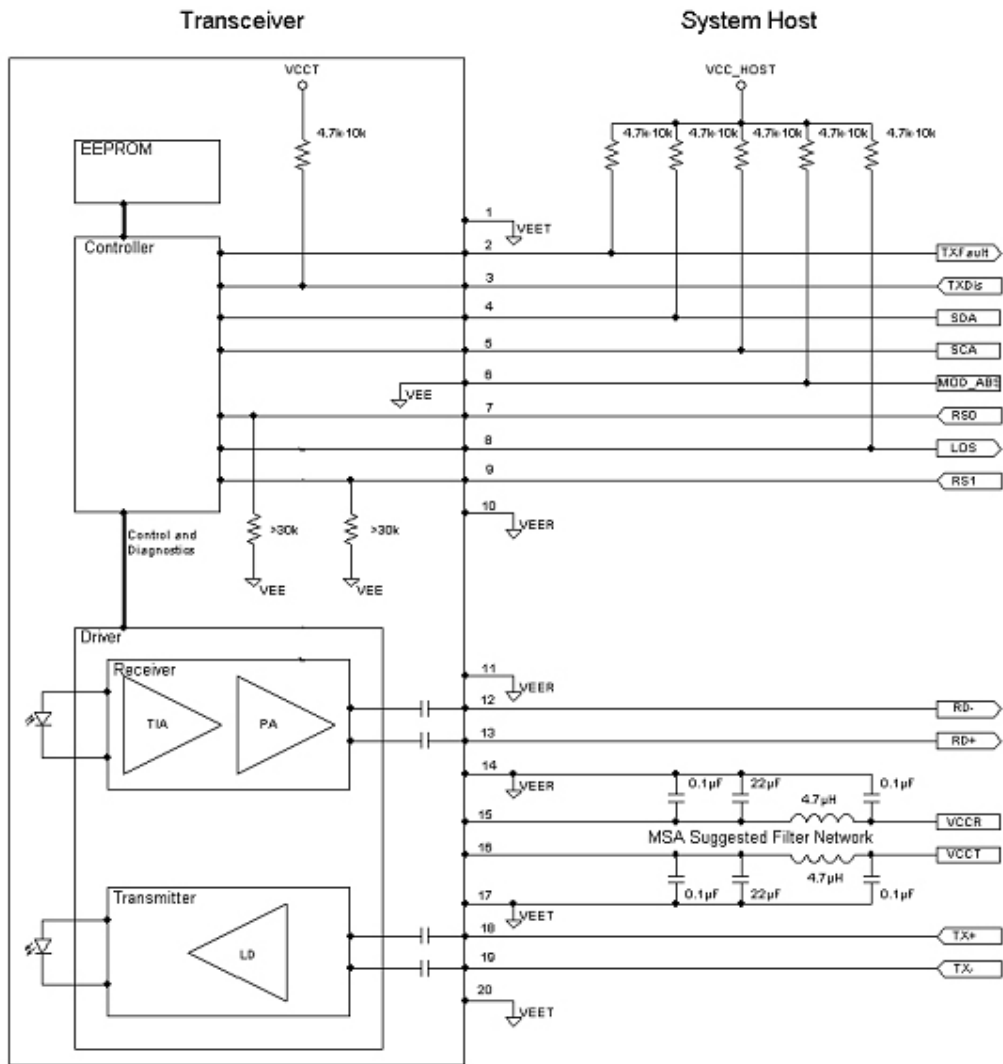

### Mechanical Specifications

SFP+ transceivers are compatible with the SFF-8432 specification for improved pluggable form factor, and shown here for reference purposes only. Bail color is Blue.

ITEM	DIM(MM)	ToL(MM)
A	19.00	
D	13.90	
E	13.70	
K	66.50	
L	1.63	
M	2.25	
P	37.10	
Q	1.50	
R	1.00	
S	8.50	
T	47.50	
W	43.00	
AL	0.60	
AK	1.80	
AQ	9.20	

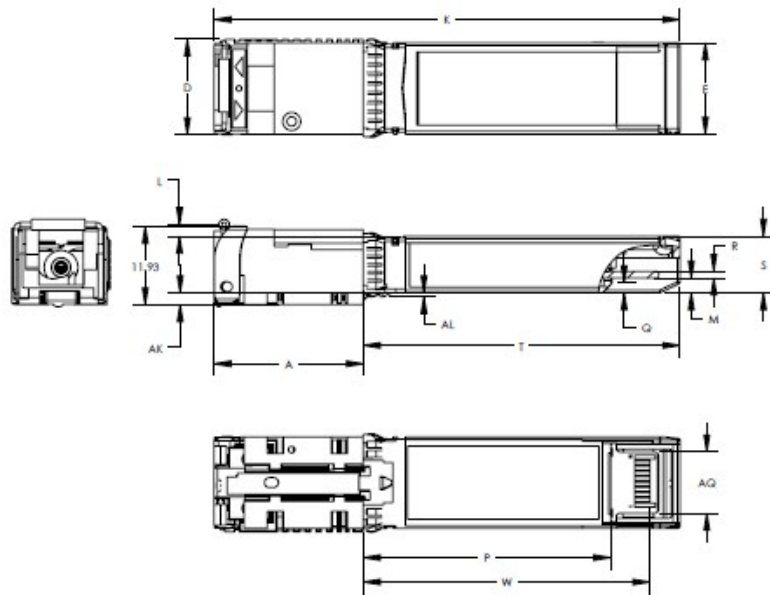

## **About AddOn Networks**

In 1999, AddOn Networks entered the market with a single product. Our founders fulfilled a severe shortage for compatible, cost-effective optical transceivers that compete at the same performance levels as leading OEM manufacturers. Adhering to the idea of redefining service and product quality not previously had in the fiber optic networking industry, AddOn invested resources in solution design, production, fulfillment, and global support.

Combining one of the most extensive and stringent testing processes in the industry, an exceptional free tech support center, and a consistent roll-out of innovative technologies, AddOn has continually set industry standards of quality and reliability throughout its history.

Reliability is the cornerstone of any optical fiber network and is engrained in AddOn's DNA. It has played a key role in nurturing the long-term relationships developed over the years with customers. AddOn remains committed to exceeding industry standards with certifications from ranging from NEBS Level 3 to ISO 9001:2005 with every new development while maintaining the signature reliability of its products.

## **U.S. Headquarters**

Email: [sales@addonnetworks.com](mailto:sales@addonnetworks.com)

Telephone: +1 877.292.1701

Fax: 949.266.9273

## **Europe Headquarters**

Email: [salesupportemea@addonnetworks.com](mailto:salesupportemea@addonnetworks.com)

Telephone: +44 1285 842070