

## SFP-50GBASE-LR-I-AO

MSA and TAA 50GBase-LR SFP56 Transceiver (SMF, 1310nm, 10km, LC, DOM, -40 to 85C)

### Features

- SFF-8431 and SFF-8472 Compliance
- Up to 53Gb/s bi-directional data links
- SFP56 package with duplex LC connector
- Cooled 1310 EML Transmitter
- PIN Receiver
- Single-mode Fiber
- Single +3.3V power supply
- Build-in DSP
- 2.5W maximum power consumption
- Class 1 laser safety certified
- Industrial Temperature -40 to 85 Celsius
- RoHS Compliant



### Applications

- 50GBase Ethernet
- Access and Enterprise

### Product Description

This MSA Compliant SFP56 transceiver provides 50GBase-LR throughput up to 10km over single-mode fiber (SMF) using a wavelength of 1310nm via an LC connector. It is built to MSA standards and is uniquely serialized and data-traffic and application tested to ensure that they will integrate into your network seamlessly. Digital optical monitoring (DOM) support is also present to allow access to real-time operating parameters. This transceiver is Trade Agreements Act (TAA) compliant. We stand behind the quality of our products and proudly offer a limited lifetime warranty.

AddOn's transceivers are RoHS compliant and lead-free.

TAA refers to the Trade Agreements Act (19 U.S.C. & 2501-2581), which is intended to foster fair and open international trade. TAA requires that the U.S. Government may acquire only "U.S. – made or designated country end products."



## Regulatory Compliance

- ESD to the Electrical PINs: compatible with MIL-STD-883E Method 3015.4
- ESD to the LC Receptacle: compatible with IEC 61000-4-3
- EMI/EMC compatible with FCC Part 15 Subpart B Rules, EN55022:2010
- Laser Eye Safety compatible with FDA 21CFR, EN60950-1& EN (IEC) 60825-1,2
- RoHS compliant with EU RoHS 2.0 directive 2015/863/EU

## Absolute Maximum Ratings

Parameter	Symbol	Min.	Typ.	Max.	Unit
Maximum Supply Voltage	V <sub>cc</sub>	-0.5		4.0	V
Storage Temperature	T <sub>S</sub>	-40		85	°C
Operating Case Temperature	T <sub>c</sub>	-40	25	85	°C
Relative Humidity	RH	5		95	%
Data Rate			53.13		Gbps

## Electrical Characteristics (TOP=25°C, V<sub>cc</sub>=3.3Volts)

Parameter	Symbol	Min.	Typ.	Max.	Unit	Notes	
Power Supply Voltage	V <sub>cc</sub>	3.135	3.3	3.465	V		
Module Supply Current	I <sub>cc</sub>			760	mA		
Power Dissipation	P <sub>D</sub>			2500	mW		
<b>Transmitter</b>							
Differential data input swing	V <sub>in</sub> , p-p			900	mVp-p		
Input differential impedance	Z <sub>in</sub>	90	100	110	Ω		
TX_FAULT	Transmitter Fault	V <sub>OH</sub>	2.0		V <sub>CCHOST</sub>	V	
	Normal Operation	V <sub>OL</sub>	0		0.8	V	
TX_DISABLE	Transmitter Disable	V <sub>IH</sub>	2.0		V <sub>CCHOST</sub>	V	
	Transmitter Enable	V <sub>IL</sub>	0		0.8	V	
<b>Receiver</b>							
Differential data output swing	V <sub>out</sub> , p-p			900	mVp-p	1	
Output differential impedance	Z <sub>o</sub>	90	100	110	Ω		
Data Output Rise Time, Fall Time	t <sub>r</sub> , t <sub>f</sub>	9.5			ps	2	
RX_LOS	Loss of signal (LOS)	V <sub>OH</sub>	2.0		V <sub>CCHOST</sub>	V	3
	Normal Operation	V <sub>OL</sub>	0		0.8	V	3

## Notes:

1. Internally AC coupled, but requires an external 100Ω differential load termination.

2. 20 – 80 %.
3. LOS is an open collector output. Should be pulled up with 4.7k $\Omega$  on the host board.

### Optical Characteristics

Parameter	Symbol	Min.	Typ.	Max.	Unit	Notes
<b>Transmitter</b>						
Launch Optical Power (average)	P <sub>AV</sub>	-4.5		+4.2	dBm	1
Launch Optical Power (OMA)	P <sub>O</sub>	-1.5		+4	dBm	1
TDECQ (50G PAM4)	TDECQ			3.2	dB	
Extinction Ratio	ER	3.5			dB	
Center Wavelength Range	$\lambda_c$	1304.5		1317.5	nm	
Spectral Width	$\Delta\lambda$			1	nm	2
Side Mode suppression Ratio	SMSR	35			dB	
Optical Return Loss Tolerance	ORLT			15.1	dB	
Pout @TX-Disable Asserted	P <sub>off</sub>			-30	dBm	
<b>Receiver</b>						
Receiver Sensitivity (average)	R <sub>AV</sub>			-10.8	dBm	3
Receiver Sensitivity (OMA)	R <sub>OMA</sub>			-7.7	dBm	3
Receiver Overload	P <sub>av</sub>	+4.2			dBm	
Optical Wavelength Range	$\lambda_c$	1260		1340	nm	
Receiver Reflectance				-26	dB	
LOS De-Assert	LOS <sub>D</sub>			-12	dBm	
LOS Assert	LOS <sub>A</sub>	-20			dBm	
LOS Hysteresis		0.5			dB	

### Notes:

1. Class 1 Laser Safety per FDA/CDRH and EN (IEC) 60825 regulations.
2. 20dB spectral width.
3. Measured with PRBS 2<sup>31</sup>-1 at 2.4 $\times$ 10<sup>-4</sup> BER.

## Pin Descriptions

Pin	Symbol	Name/Descriptions	Notes
1	VeeT	Transmitter Ground	1
2	TX_Fault	Transmitter Fault (LVTTTL-O) - High indicates a fault condition	2
3	TX_Disable	Transmitter Disable (LVTTTL-I) – High or open disables the transmitter	3
4	SDA	Two wire serial interface Data Line (LVCMOS-I/O) (MOD-DEF2)	4
5	SCL	Two wire serial interface Clock Line (LVCMOS-I/O) (MOD-DEF1)	4
6	MOD_ABS	Module Absent (Output), connected to VeeT or VeeR in the module	5
7	RS0	NA	6
8	RX_LOS	Receiver Loss of Signal (LVTTTL-O)	2
9	RS1	NA	6
10	VeeR	Receiver Ground	1
11	VeeR	Receiver Ground	1
12	RD-	Inverse Received Data out (CML-O)	
13	RD+	Received Data out (CML-O)	
14	VeeR	Receiver Ground	
15	VccR	Receiver Power - +3.3V	
16	VccT	Transmitter Power - +3.3 V	
17	VeeT	Transmitter Ground	1
18	TD+	Transmitter Data In (CML-I)	
19	TD-	Inverse Transmitter Data In (CML-I)	
20	VeeT	Transmitter Ground	1

### Notes:

1. The module signal grounds are isolated from the module case.
2. This is an open collector/drain output that on the host board requires a 4.7K $\Omega$  to 10K $\Omega$  pull-up resistor to Vcc-Host.
3. This input is internally biased high with a 4.7K $\Omega$  to 10K $\Omega$  pull-up resistor to VccT.
4. Two-Wire Serial interface clock and data lines require an external pull-up resistor.
5. This is a ground return that on the host board requires a 4.7K $\Omega$  to 10K $\Omega$  pull-up resistor to Vcc-Host.
6. Rate select not available

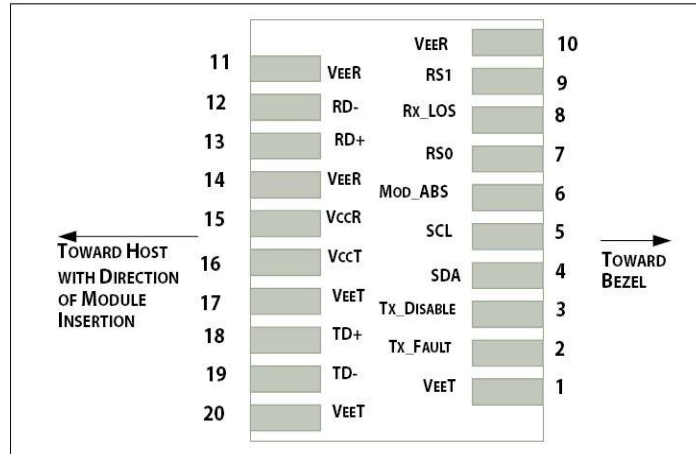

Host PCB SFP28 Pad Assignment Top View

**Recommended Host Board Power Supply Filter Network**

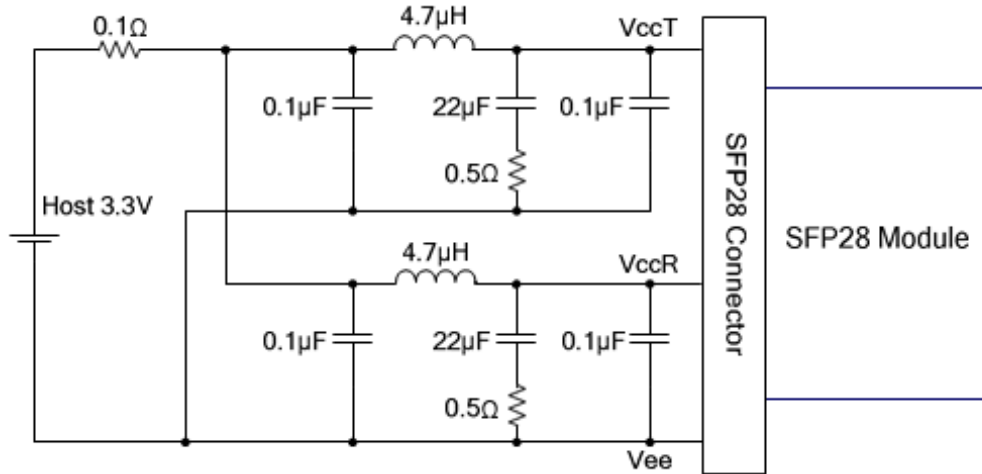

## Recommended Application Interface Block Diagram

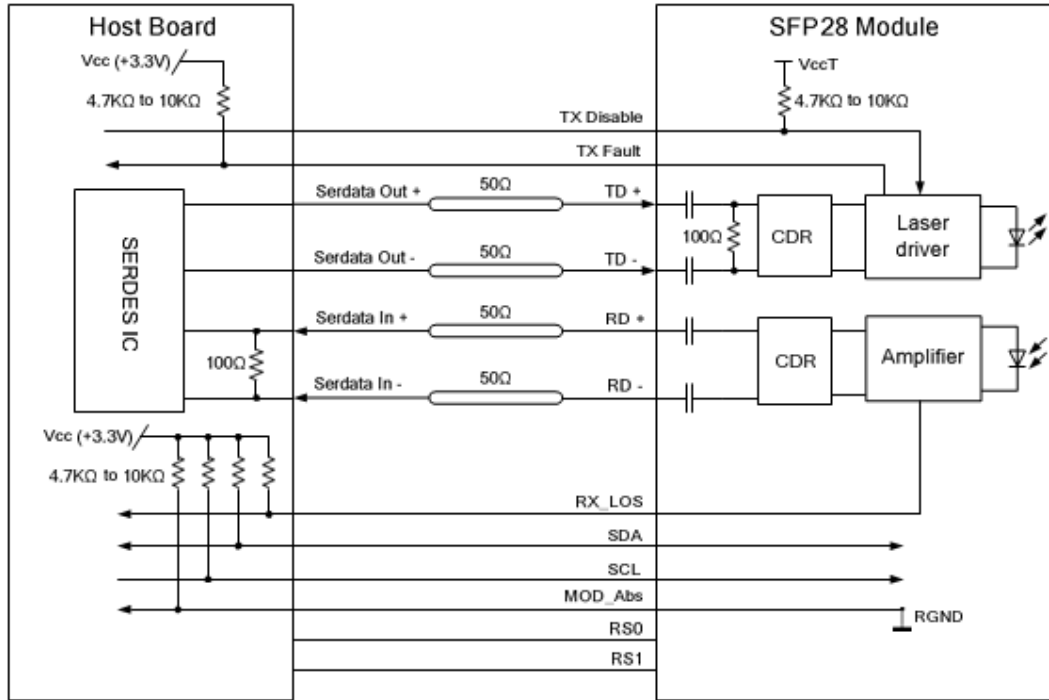

## Mechanical Specifications

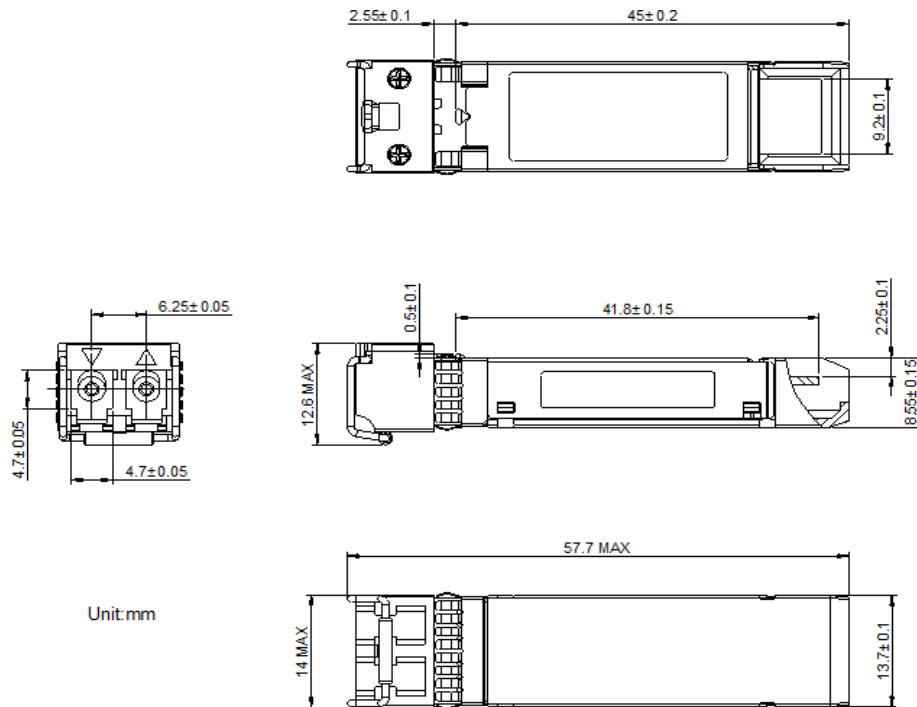

## **About AddOn Networks**

In 1999, AddOn Networks entered the market with a single product. Our founders fulfilled a severe shortage for compatible, cost-effective optical transceivers that compete at the same performance levels as leading OEM manufacturers. Adhering to the idea of redefining service and product quality not previously had in the fiber optic networking industry, AddOn invested resources in solution design, production, fulfillment, and global support.

Combining one of the most extensive and stringent testing processes in the industry, an exceptional free tech support center, and a consistent roll-out of innovative technologies, AddOn has continually set industry standards of quality and reliability throughout its history.

Reliability is the cornerstone of any optical fiber network and is engrained in AddOn's DNA. It has played a key role in nurturing the long-term relationships developed over the years with customers. AddOn remains committed to exceeding industry standards with certifications from ranging from NEBS Level 3 to ISO 9001:2005 with every new development while maintaining the signature reliability of its products.

## **U.S. Headquarters**

Email: [sales@addonnetworks.com](mailto:sales@addonnetworks.com)

Telephone: +1 877.292.1701

Fax: 949.266.9273

## **Europe Headquarters**

Email: [salesupportemea@addonnetworks.com](mailto:salesupportemea@addonnetworks.com)

Telephone: +44 1285 842070