



# Maintenance and Service Guide

## E23 G4/E24 G4 model

### **SUMMARY**

This guide provides information about spare parts, removal and replacement of parts, diagnostic tests, problem troubleshooting, and more.

© Copyright 2021 HP Development Company, L.P.

AMD is a trademark of Advanced Micro Devices, Inc. Bluetooth is a trademark owned by its proprietor and used by HP Inc. under license. NVIDIA is a trademark and/or registered trademark of NVIDIA Corporation in the U.S. and other countries. USB Type-C and USB-C are registered trademarks of USB Implementers Forum. DisplayPort and the DisplayPort logo are trademarks owned by the Video Electronics Standards Association (VESA) in the United States and other countries.

The information contained herein is subject to change without notice. The only warranties for HP products and services are set forth in the express warranty statements accompanying such products and services. Nothing herein should be construed as constituting an additional warranty. HP shall not be liable for technical or editorial errors or omissions contained herein.

First Edition: May 2021

Document Part Number: L97368-E23 G4 - MSG-V2

Assembly part number: L97368-001 (E23 G4), L97371-001 (E24 G4)

#### **Product notice**

Only trained service personnel familiar with this product should service it. Before performing any maintenance or service, be sure to read "Important Safety Information".

# Table of Contents

1	Getting started .....	1
	Important safety information .....	1
	Important service information and precautions .....	1
	RoHS (2002/95/EC) requirements .....	2
	General descriptions .....	2
	Firmware updates .....	2
	Before returning the repaired product to the customer .....	2
2	Monitor features .....	3
	Features .....	3
	Front components .....	4
	Rear and side components .....	5
	Locating the serial number and product number .....	6
3	Illustrated parts catalog .....	8
	How to order parts .....	9
4	Removal and replacement procedures .....	11
	Preparation for disassembly .....	11
	RC .....	11
	Power board .....	14
	Connector repair .....	16
	D-Sub connector CRT1 .....	16
	HDMI connector HDMI1 .....	17
	DP connector DP1 .....	17
	USB-B connector USB1 .....	18
	USB-A connector USB2 .....	19
	Function test .....	19
	Support and troubleshooting .....	20
	Index .....	22

---

# 1 Getting started

Read this chapter to learn about safety information and where to find additional HP resources.

## Important safety information

Carefully read the cautions and notes within this document to minimize the risk of personal injury to service personnel. The cautions and notes are not exhaustive. Proper service methods are important to the safe, reliable operation of equipment. Improper service methods can damage equipment.

The service procedures recommended and described in this service manual provide effective methods of performing service operations. Service engineers should have prior repair knowledge and experience as well as appropriate training for the product before performing service procedures.

- Be sure your working environment is dry and clean and meets all government safety requirements.
- Be sure that other persons are safe while you are servicing the product.
- Do not perform any action that can cause a hazard to the customer or make the product unsafe.
- Use proper safety devices to ensure your personal safety.
- Always use approved tools and test equipment for servicing.
- Never assume the product's power is disconnected from the main power supply. Check that it is disconnected before opening the product's cabinet.
- Modules containing electrical components are sensitive to electrostatic discharge (ESD). Follow ESD safety procedures while handling these parts.
- Some products contain more than one battery. Do not disassemble or expose a battery to high temperatures, such as throwing into fire, or the battery may explode.
- Refer to government requirements for battery recycling or disposal.

This information provides general service information for the monitor. Adherence to the procedures and precautions is essential for proper service.

---

**IMPORTANT:** Only trained service personnel who are familiar with this HP product should perform service or maintenance for it. Before performing any service or maintenance, personnel must read the important safety information.

---

**IMPORTANT:** You must disconnect the power cord from the power source before opening the monitor to prevent component damage.

---

## Important service information and precautions

- Repair must be performed by professional service technicians in a repair center. End users should not perform these procedures.
- Please note during servicing that the primary side is the high voltage area.
- This monitor meets ROHS requirements. Be sure to use lead-free solder wire when soldering.
- If you must change a capacitor, be sure to match the polarity as printed on the PCB.
- If you must replace a capacitor, make sure the specification and part number match the BOM and location.
- If you must replace a capacitor, insert new parts carefully to avoid a short circuit caused by the near

pin.

- Do not get the board wet. Water and moisture can cause a short circuit that causes malfunctions.
- To avoid damage, be sure to use lead-free solder.
- When soldering, work quickly to avoid overheating the circuit board.
- Keep the soldering iron tip clean and well tinned when replacing parts.
- After repair, perform a close inspection of the circuit board to confirm it is in good condition.
- After repair, perform a function test to confirm the power supply is working properly.

#### **ERP Lot5 requirement**

1. A professional repairer must have the technical competence to repair electronic displays and comply with the applicable regulations for repairers of electrical equipment in the Member States where the repairer operates. Reference to an official registration system as professional repairer, where such a system exists in the Member States, shall be accepted as proof of compliance.

2. A professional repairer must have insurance that covers liabilities resulting from repairs, regardless of whether required by the Member State.

## **RoHS (2002/95/EC) requirements**

### **Applied to all countries that require RoHS.**

The RoHS (Restriction of Hazardous Substance in Electrical and Electronic Equipment Directive) is a legal requirement by the EU (European Union) for the global electronics industry sold in the EU and other countries. Any electrical and electronics products launched in the market after June 2006 should meet this RoHS requirement. Products launched in the market before June 2006 are not required to be compliant with RoHS parts. If the original parts are not RoHS compliant, the replacement parts can be non-ROHS compliant. If the original parts are RoHS compliant, the replacement parts **MUST** be RoHS compliant.

If product service or maintenance requires replacing parts, confirm the RoHS requirement before replacement.

## **General descriptions**

This manual contains general information. There are two levels of service:

Level 1: Cosmetic/appearance/alignment service

Level 2: Circuit board or standard parts replacement

## **Firmware updates**

Firmware updates for the monitor are available at [support.hp.com](http://support.hp.com). If no firmware is posted, the monitor does not need a firmware update.

## **Before returning the repaired product to the customer**

Perform an AC leakage current check on exposed metallic parts to be sure the product is safe to operate without the potential of electrical shock. Do not use a line isolation transformer during this check.

Measurements that are not within specified limits present a possible shock hazard. You must check and repair the product before returning it to the customer.

---

## 2 Monitor features

This chapter provides an overview of the monitor's features.

### Features

Depending on the model, your monitor might include the following features:

- The following models, which include full-screen support for lower resolutions; includes custom scaling for maximum image size while preserving original aspect ratio:
  - 60.5 cm (23.8 in) diagonal viewable screen area with 1920 × 1080 resolution
  - 58.4 cm (23.0 in) diagonal viewable screen area with 1920 × 1080 resolution
- In-plane switching (IPS) panel
- Nonglare panel with an LED backlight
- Wide viewing angle to allow viewing from a sitting or standing position, or moving from side to side
- Tilt, swivel, and height adjustment capabilities
- Pivot capability to rotate the monitor head from landscape to portrait orientation
- Removable stand for flexible monitor head mounting solutions
- HP Quick Release 2 device to quickly attach the monitor head to the stand with a simple click, and then remove it with the convenient sliding tab release
- DisplayPort™ video input (cable included)
- High-Definition Multimedia Interface™ (HDMI) video input (cable included)
- VGA video input (cable included in select regions)
- USB hub with one USB Type-B port (cable included) that connects to the computer (upstream) and four USB ports that connect to USB devices (downstream)
- Four on-screen display (OSD) buttons, three that you can reconfigure to quickly allow selection of the most commonly used operations
- Plug and Play capability if supported by your operating system
- VESA® mounting bracket for attaching the monitor head to a wall-mount device or swing arm
- Security cable slot on the rear of the monitor for an optional security cable
- Cable management feature for placement of cables and cords
- On-screen adjustments in several languages for easy setup and screen optimization
- Energy saver feature to meet requirements for reduced power consumption

---

**NOTE:** For safety and regulatory information, refer to the Product Notices provided in your documentation kit. To access the latest user guides or manuals for your product, go to <http://www.hp.com/support> and follow the instructions to find your product. Then select **Manuals**.

---

# Front components

To identify the components on the front of the monitor, use this illustration and table.

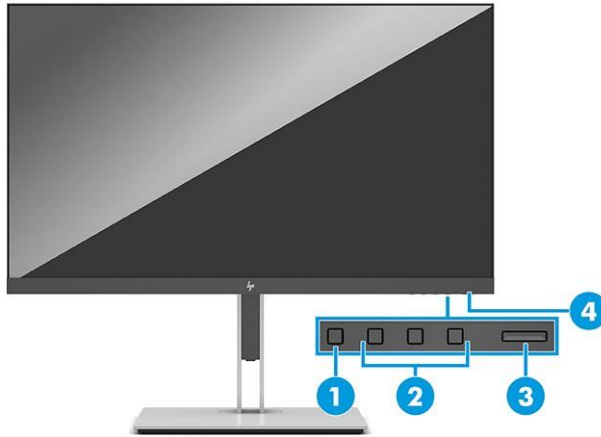
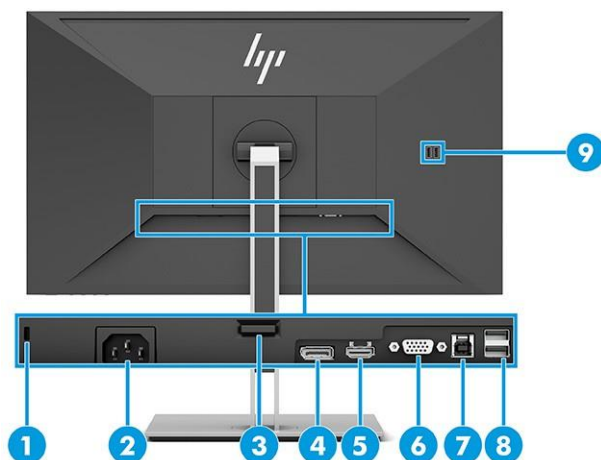

**Table 2-1 Front components and their descriptions**

Component	Description
(1) Menu button	Press to open the OSD menu and select a menu item from the OSD.
(2) OSD buttons (assignable)	When the OSD menu is open, press the buttons to navigate through the menu. The function light icons indicate the default button functions. You can reassign the function buttons to quickly select the most commonly used operations
(3) Power button	Turns the monitor on or off.
(4) Power light	White: The monitor is on. Amber: Monitor is in a reduced power state because of inactivity.

## Rear and side components

To identify the components on the rear of the monitor, use this illustration and table.



**Table 2-2 Rear and side components and their descriptions**

Component	Description
(1) Security cable slot	Connects an optional security cable.
(2) Power connector	Connects the power cord.
(3) VESA release button	Releases the stand from the monitor.
(4) DisplayPort connector	Connects the DisplayPort cable to a source device such as a computer or game console.
(5) HDMI port	Connects the HDMI cable to a source device such as a computer or game console.
(6) VGA port	Connects the VGA cable to the source device.
(7) USB Type-B port (upstream)	Connects the USB Type-B cable to a source device such as a computer or game console. <b>NOTE:</b> A USB Type-B cable or a USB Type-C cable must be connected from the source device to the monitor to enable USB Type-A ports on the monitor.
(8) USB ports (2) (downstream)	Connect a USB cable to a peripheral device, such as a keyboard, mouse, or USB hard drive.
(9) USB ports (2) (downstream)	Connect a USB cable to a peripheral device, such as a keyboard, mouse, or USB hard drive.



# Locating the serial number and product number

The Spec label (1) and Barcode label (2) are located on the rear of the monitor. The serial number and product number are located on a Safety label. You may need these numbers when contacting HP about the monitor model.

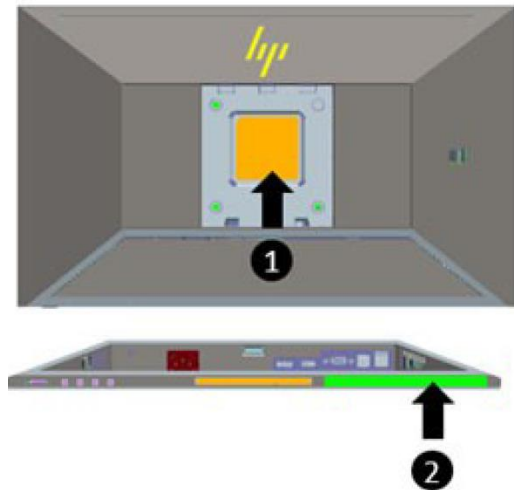

## For worldwide models(except India):

### Barcode label for E23 G4

<p>HP E23 G4 FHD Monitor    Serial No. 序号/序號</p> <p>Regulatory Model No. / 规范型号 / 规范型号 / 空型号: HSD-0053-W          型号/型号: E23 G4    液晶显示屏尺寸/液晶显示屏尺寸: 58.4 cm (23 in.)          Input Rating 电源电压 / 输入电压 / 交流电 / 交流电: 100-240V (伏特) - 15A (15A) 安培 50 / 60 Hz (赫兹)</p>	<p>Product No.: [A]</p> <p>Manufactured 制造/製造 日期: [B]</p> <p>制造商: HP Inc.    Made in China / Fabriqué en Chine / 制造地: 中国</p>	<p>Assembly Part No.: [C]</p> <p>Spares No.: [D]</p> <p>Rev.: [E]</p>
--	--	---

### Barcode label for E24 G4

<p>HP E24 G4 FHD Monitor    Serial No. 序号/序號</p> <p>Regulatory Model No. / 规范型号 / 规范型号 / 空型号: HSD-0054-W          型号/型号: E24 G4    液晶显示屏尺寸/液晶显示屏尺寸: 60.5 cm (23.8 in.)          Input Rating 电源电压 / 输入电压 / 交流电 / 交流电: 100-240V (伏特) - 15A (15A) 安培 50 / 60 Hz (赫兹)</p>	<p>Product No.: [A]</p> <p>Manufactured 制造/製造 日期: [B]</p> <p>制造商: HP Inc.    Made in China / Fabriqué en Chine / 制造地: 中国</p>	<p>Assembly Part No.: [C]</p> <p>Spares No.: [D]</p> <p>Rev.: [E]</p>
--	--	---

## For India:

### Barcode label for E23 G4

<p>HP E23 G4 FHD Monitor    Serial No. 序号/序號</p> <p>Regulatory Model No. / 规范型号 / 规范型号 / 空型号: HSD-0053-W          型号/型号: E23 G4    液晶显示屏尺寸/液晶显示屏尺寸: 58.4 cm (23 in.)          Input Rating 电源电压 / 输入电压 / 交流电 / 交流电: 100-240V (伏特) - 15A (15A) 安培 50 / 60 Hz (赫兹)</p> <p>IS 13252 (Part 1) IEC 60950-1 R-41081153 www.hp.com/in</p>	<p>Product No.: [A]</p> <p>Manufactured 制造/製造 日期: [B]</p> <p>Made in China / Fabriqué en Chine / 制造地: 中国</p>	<p>Assembly Part No.: [C]</p> <p>Spares No.: [D]</p> <p>Rev.: [E]</p>
--	--	---

### Barcode label for E24 G4

<p>HP E24 G4 FHD Monitor    Serial No. 序号/序號</p> <p>Regulatory Model No. / 规范型号 / 规范型号 / 空型号: HSD-0054-W          型号/型号: E24 G4    液晶显示屏尺寸/液晶显示屏尺寸: 60.5 cm (23.8 in.)          Input Rating 电源电压 / 输入电压 / 交流电 / 交流电: 100-240V (伏特) - 15A (15A) 安培 50 / 60 Hz (赫兹)</p> <p>IS 13252 (Part 1) IEC 60950-1 R-41081153 www.hp.com/in</p>	<p>Product No.: [A]</p> <p>Manufactured 制造/製造 日期: [B]</p> <p>Made in China / Fabriqué en Chine / 制造地: 中国</p>	<p>Assembly Part No.: [C]</p> <p>Spares No.: [D]</p> <p>Rev.: [E]</p>
--	--	---

## Spec label for E23 G4(WW & India)



Spec label for E24 G4(WW & India)



# 3 Illustrated parts catalog

To identify the monitor major components, use this illustration and table.

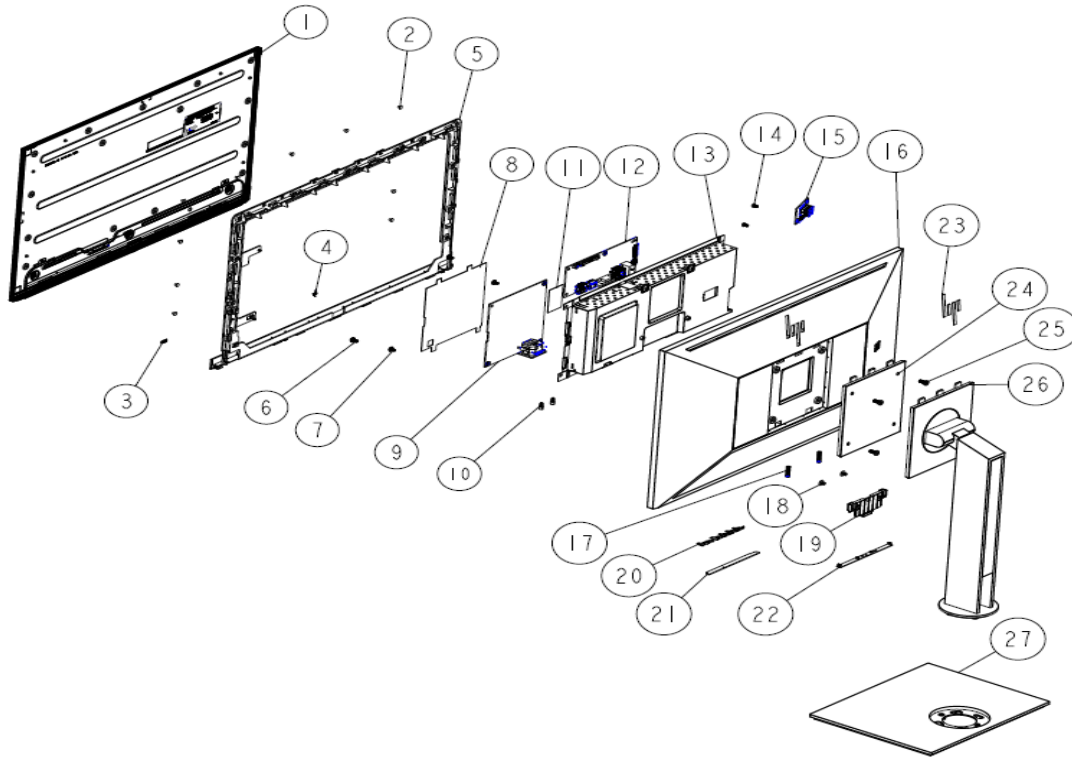

**Table 3-1:** Monitor major components and their descriptions

Item	Description	Part number	Qty
1	#ASSY Panel		1
2	#Screw		11
3	#Lens		1
4	#HP Front LOGO		1
5	#Mid cover- E23 G4		1
6	#Grounding Screw		1
7	# PCB Screw		1
8	#Safety Mylar		1
9	#Assy Power BD		1
10	#VGA Screws		2
11	#Hit pot Mylar		1
12	#Assy IF BD		1
13	#ASSY Main chassis		1
14	#USB BD Screws		2

15	#ASSY USB BD	1
16	#ASSY Rear cover	1
17	#Spring	2
18	#Screw	2
19	#Slider	1
20	#OSD key	1
21	#OSD key BD	1
22	#Speaker cover	1
23	#HP Rear LOGO	1
24	#VESA Cosmetic cover	1
25	#Wall mount Screws	4
26	#ASSY Stand	1
27	#ASSY Base	1

## How to order parts

The HP authorized repair center can purchase the power board from HP.

### Power board

Description	HP spare part number	Manufacturer part number
POWER BD RB23HHC-XUS(C)E23 G4 D	M84511-001	755.06704.0001
POWER BD RB23HHC-XUL(C)E23 G4 D	M84512-001	755.06704.0002
POWER BD RB23HHC-XUE(C)E23 G4 D	M84513-001	755.06704.0003
POWER BD RB238HC-XUD(C) E24 G4 DIP	M84514-001	755.06602.0001
POWER BD RB238HC-XUU(C) E24 G4 DIP	M84515-001	755.06602.0002
POWER BD RB238HC-XUM(C) E24 G4 DIP	M84516-001	755.06602.0003
POWER BD RB238HC-XUS(C) E24 G4 DIP	M84517-001	755.06602.0004
POWER BD RB238HC-XUE(C) E24 G4 DIP	M84518-001	755.06602.0005
POWER BD RB238HC-XUL(C) E24 G4 DIP	M84519-001	755.06602.0006

Capacitors and connectors are available for purchase from the following EU distributors:

- SUSCON : [www.su-scon.com](http://www.su-scon.com)
- CAPXON: [www.capxongroup.com](http://www.capxongroup.com)

### Capacitors by distributor

Component description	Location	Component distributor	Distributor part number
CAP EL 470U 25V M RT5 10*16 HG	PT503,PT504,PT506	SUSCON	HG025M471G16T014P50R
CAP EL 470U 25V M RT5 10*16 FH CAPXON		CAPXON	FH471M025G160ETABZ

## Connectors by manufacturer

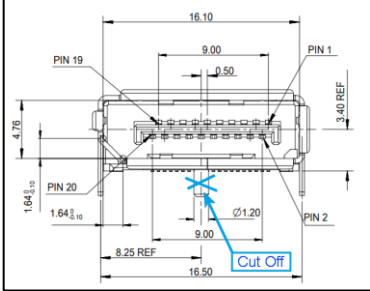
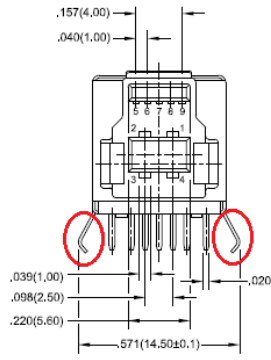
Component description	Location identifier	Component distributor	Distributer part number	Remark
D-Sub	CRT1	Kycon, Inc.	<a href="https://www.digikey.com">https://www.digikey.com</a> PN 2092-K61X-E15S-N-ND	
HDMI	HDMI1	Switchcraft Inc.	<a href="https://www.digikey.com">https://www.digikey.com</a> PN: 137-RAHHD19TR-ND	
DP	DP1	Molex	<a href="https://www.digikey.com">https://www.digikey.com</a> PN: WM14328DKR-ND	<p>1. Only DP1.1 2. Cut off the through hole</p> 
USB-B	USB1	EDAC Inc.	<a href="https://www.digikey.com">https://www.digikey.com</a> PN: 690-009-521-900	<p>Straighten the Pin as below</p> 
USB-A	USB2	Molex	<a href="https://www.digikey.com">https://www.digikey.com</a> PN: WM10420-ND	

**NOTE:** The connector may need to be modified to meet functionality, regulatory and safety requirements if it is not an exact match.

You can purchase cables from the HP part store at <https://partsurfer.hp.com/Search.aspx>.

**NOTE:** HP continually improves and changes product parts. For complete and current information about supported parts for your computer, go to <http://partsurfer.com>, select your country or region, and then follow the on-screen instructions.

## 4 Removal and replacement procedures

Adherence to these procedures and precautions is essential for proper service.

### Preparation for disassembly

Use this information to properly prepare to disassemble and reassemble the monitor.

- 1) Read the “Important safety information” and “Important service information and precautions” sections in the “Getting started” chapter of this guide.
- 2) Clean the room for disassembly.
- 3) Identify the disassembly area.
- 4) Check the position that the monitors are to be placed along with the number of monitors. Prepare the area for material flow according to the disassembly layout.
- 5) Be sure to have the following equipment and materials:
  - Press fixture
  - Working table
  - Screwdriver
  - Knife
  - Gloves
  - Cleaning cloth
  - ESD protection
  - Scraper bar in the following dimensions:

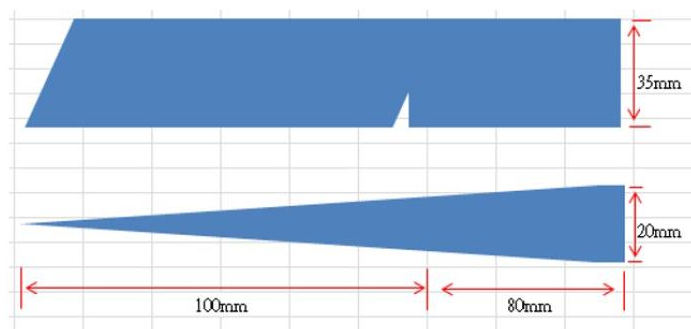

### RC

Before removing the RC, follow these steps:

- ▲ Prepare the monitor for disassembly. See Preparation for disassembly on page 11.
- 1) Pull the release button to Remove Stand Base From Display Head



2) Remove 4 screws, and Pull the rear cover to remove Rear cover



3) Remove USB BD Screws to remove USB BD. Release OSD key BD from rear cover

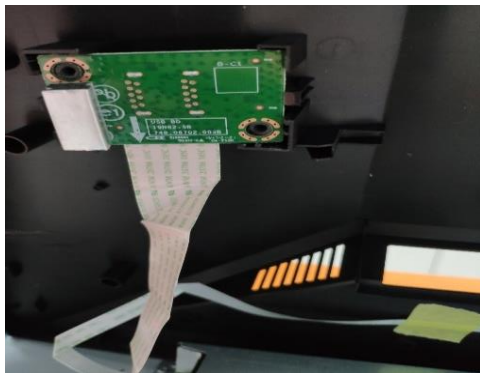

4) Remove all cables and tape to remove main chassis ASSY





5) Release all screws, remove Mid-cover ASSY



6) Remove black Mylar

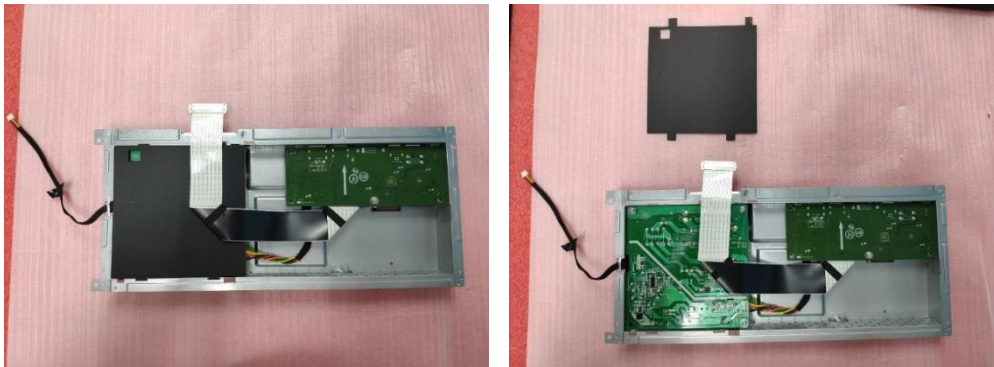

7) Remove 2pcs VGA screws, 5pcs PCB screws to remove PCB BD





## Power board

The power board part number is 755.06704.0001 or refer to page 9.

Before removing the power board, follow these steps:

- ▲ Prepare the monitor for disassembly. See Preparation for disassembly on page 11.

Remove the power board:

- 1) The HP E23&E24 G4 power board connector position is as follows:

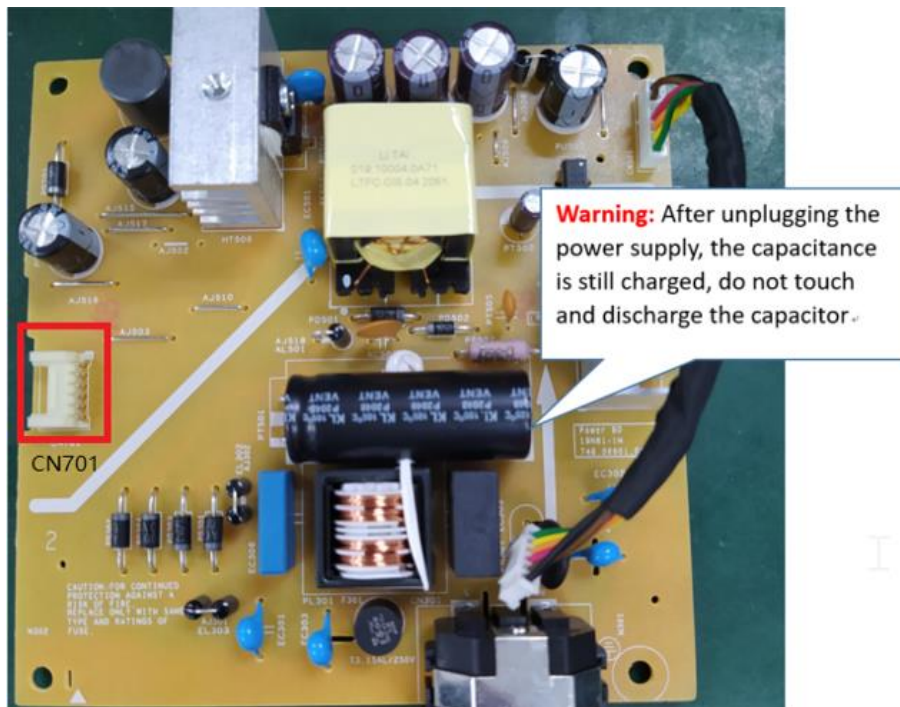

CN701 Wistron P/N: 021.60237.0106

- 2) Locate the part number location on the board.

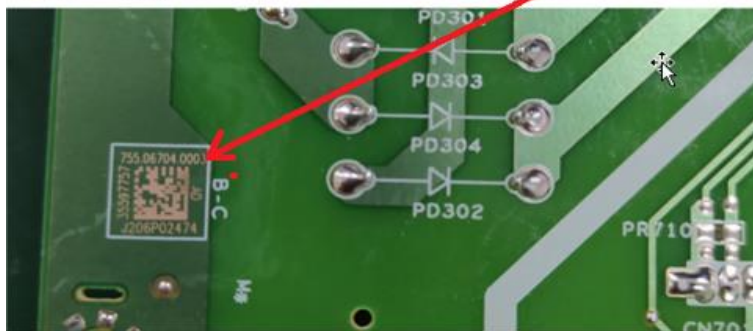
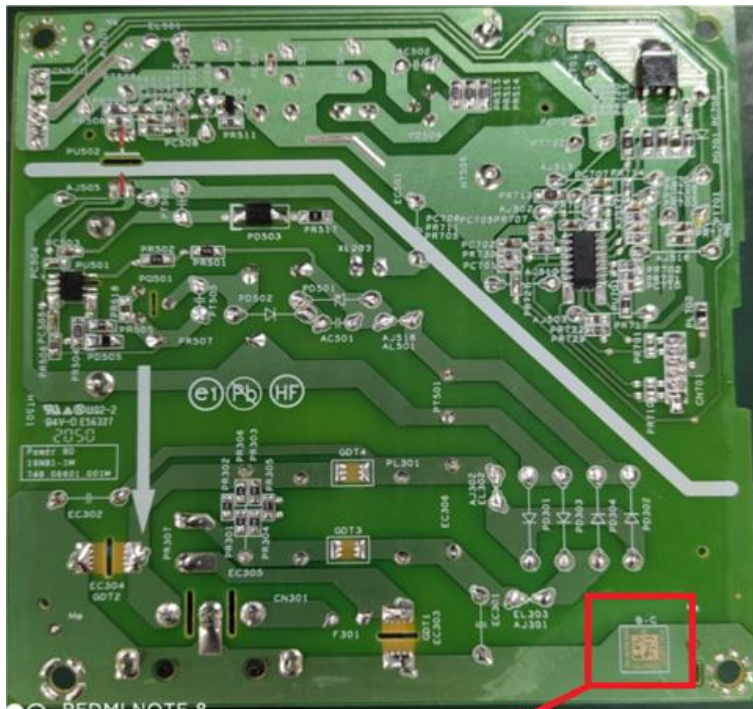

- 3) Pin solder with soldering iron and absorber. CN701



- 4) Lift the connector up and away from the PCB. CN701

# Connector repair

This procedure includes HDMI, Display Port, USB-B, USB-A connectors.

The connectors are on the main board (board part number 7ZB.06701.0006).

The connector identifiers are as follows:

Connector	Location
D-Sub	CRT1
HDMI	HDMI1
DP	DP1
USB-B	USB1
USB-A	USB2

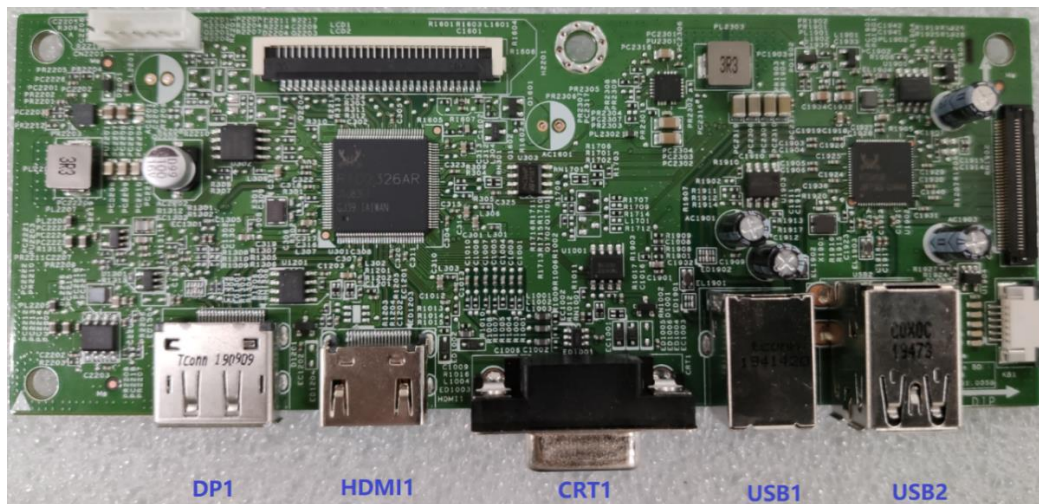

Before repairing connectors, follow these steps:

- ▲ Prepare the monitor for disassembly. See [Preparation for disassembly](#) on page 11.

## D-Sub connector CRT1

Repair the D-Sub connector:

- 1) Use a soldering iron and a de-soldering pump to remove as much solder as possible from the pin.





- 2) Lift the D-Sub connector from the PCB.
- 3) Place the new component on the PCB. Be sure that it matches the PCB footprint.
- 4) Solder the new component.

## HDMI connector HDMI1

Repair the HDMI connector:

- 1) Use a soldering iron and a de-soldering pump to remove as much solder as possible from the pin.



- 2) Use a hot air gun to melt the solder on the pins.

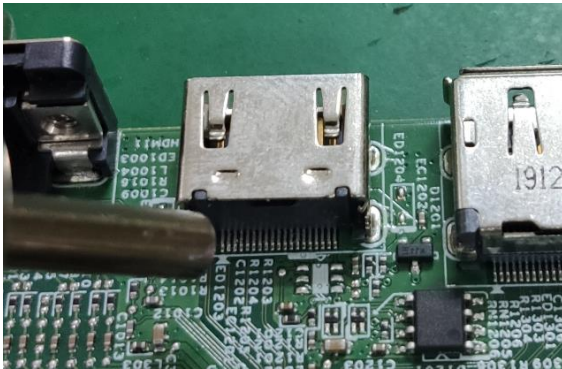

- 3) Lift the HDMI connector from the PCB.
- 4) Place the new component on the PCB. Be sure that it matches the PCB footprint.
- 5) Solder the new component.

## DP connector DP1

Repair the DP connector:

- 1) Use a soldering iron and a de-soldering pump to remove as much solder as possible from the pin.



- 2) Use a hot air gun to melt the solder on the pins.



- 3) Lift the DP connector from the PCB.
- 4) Place the new component on the PCB. Be sure that it matches the PCB footprint.
- 5) Solder the new component.

## USB-B connector USB1

Repair the USB-B connector:

- 1) Use a soldering iron and a de-soldering pump to remove as much solder as possible from the pin.



- 2) Lift the USB-B connector from the PCB.
- 3) Place the new component on the PCB. Be sure that it matches the PCB footprint.

- 4) Solder the new component.

## USB-A connector USB2

Repair the USB-A connector:

- 1) Use a hot air gun to melt the solder on the pins. Pin solder with soldering iron and absorber. You can gently push down with the soldering iron once everything is molten to move USB-A connector out of the through holes.



- 2) Lift the USB-A connector from the PCB.
- 3) Place the new component on the PCB. Be sure that it matches the PCB footprint.
- 4) Solder the new component

## Function test

After repair, be sure to confirm that all functions are working.

**Table 4-1:** Function test

Test item	Operating description	Tool used
D-Sub test	Confirm whether image displays plays correctly on the monitor.	Computer or Notebook
HDMI test	Confirm whether image displays and sound plays correctly on the monitor.	Computer or DVD player
DP test	Confirm whether image displays and sound plays correctly on the monitor.	Computer or DVD player
USB Hub Test	Confirm USB function of 2-USB Type-A working normally.	Computer or Notebook

# Support and troubleshooting

The following table lists possible problems, the possible cause or each problem, and the recommended solutions.

**Table 4-2:** Solving common problems

<b>Problem</b>	<b>Possible cause</b>	<b>Solution</b>
Screen is blank or video is flashing.	Power cord is disconnected.	Connect the power cord.
	Monitor is turned off.	Power the power button. NOTE: If pressing the Power button has no effect, press and hold the power button for 10 seconds to disable the Power button lockout feature.
	Video cable is improperly connected.	Connect the video cable properly.
	System is in Sleep mode.	Press any key on the keyboard or move the mouse to exit Sleep mode.
	Video card is incompatible.	Open the OSD menu and select the <b>Input</b> menu. Set <b>Auto-Switch Input</b> to <b>Off</b> and manually select the input.  or Replace the video card or connect the video cable to one of the computer's on-board video sources.
Image appears blurred, indistinct, or too dark.	Brightness is too low.	Open the OSD menu and select <b>Brightness</b> to adjust the brightness scale as needed.
<b>Check Video Cable</b> is displayed on screen.	Monitor video cable is disconnected.	Connect the appropriate video signal cable between the computer and monitor. Be sure that the computer power is off while you connect the video cable.
<b>Input Signal Out of Range</b> is displayed on screen.	Video resolution and/or refresh rate are set higher than what the monitor supports.	Change the settings to a supported setting.
The monitor does not enter into a low-power sleep state.	The monitor's power saving control is disabled.	Open the OSD menu and select <b>Power</b> , select <b>Auto-Sleep Mode</b> and set auto-sleep to <b>On</b> .
"OSD Lockout" is displayed.	The monitor's OSD lock function is enabled.	Press and hold the <b>Menu</b> button to disable the OSD lockout function.

---

“Power Button  
Lockout” is  
displayed.

The monitor’s power button is locked.

Press and hold the **Power**  
button for 10 seconds to  
disable the power button  
lock function.

---



# Index

- components
  - front, 4
  - rear, 5
- connector repair, 16
- features, 3
- firmware updates, 2
- front components, 4
- function test, 19
- how to order parts, 9
- illustrated parts catalog, 8
- parts, 8
- parts, ordering, 9
- power board removal, 14
- precautions, 1
- preparation for disassembly, 11
- RC removal, 11
- rear components, 5
- removal
  - power board, 14
  - RC, 11
- removal and replacement procedures, 11
- returning to customer, 2
- RoHS (2002/95/EC) requirements, 2
- safety information, 1
- serial number location, 6
- service information, 1
- spare parts, 8
- support and troubleshooting, 20
- troubleshooting, 20