

QSFP-100GCWDM4L-S-AO

Cisco® QSFP-100G-CWDM4L-S Compatible 100GBase-CWDM4 QSFP28 Transceiver (SMF, 1270nm to 1330nm, 500m, LC, DOM, Limited Temp 15C to 55C)

Features

- SFF-8636/ 8661/ 8679/ 8682 Compliance
- Single-mode Fiber
- Duplex LC Connector
- Integrated CWDM DFB TOSA (1271,1291,1311,1331nm) and PIN ROSA
- Supports 25.78125Gbps Data rate per wavelength
- Single-mode Fiber
- DDM function implemented
- Build in CDR on both TX and RX
- Operating case temperature: 15~55C
- Hot pluggable QSFP28 form factor
- Power consumption: 3.5W
- RoHS6 Compliant



Applications

- Ethernet over CWDM
- Access, Metro and Enterprise

Product Description

This Cisco® QSFP-100G-CWDM4L-S-XXX compatible QSFP28 transceiver provides 100GBase-CWDM4 throughput up to 500m over single-mode fiber (SMF) using wavelengths between 1270nm to 1330nm via an LC connector. It is guaranteed to be 100% compatible with the equivalent Cisco® transceiver. This easy to install, hot swappable transceiver has been programmed, uniquely serialized and data-traffic and application tested to ensure that it will initialize and perform identically. Digital optical monitoring (DOM) support is also present to allow access to real-time operating parameters. This transceiver is Trade Agreements Act (TAA) compliant. We stand behind the quality of our products and proudly offer a limited lifetime warranty.

AddOn's transceivers are RoHS compliant and lead-free.

TAA refers to the Trade Agreements Act (19 U.S.C. & 2501-2581), which is intended to foster fair and open international trade. TAA requires that the U.S. Government may acquire only "U.S. – made or designated country end products."



Regulatory Compliance

- ESD to the Electrical PINs: compatible with MIL-STD-883E Method 3015.4
- ESD to the LC Receptacle: compatible with IEC 61000-4-3
- EMI/EMC compatible with FCC Part 15 Subpart B Rules, EN55022:2010
- Laser Eye Safety compatible with FDA 21CFR, EN60950-1& EN (IEC) 60825-1,2
- RoHS compliant with EU RoHS 2.0 directive 2015/863/EU

Absolute Maximum Ratings

Parameter	Symbol	Min.	Typ.	Max.	Unit
Maximum Supply Voltage	V _{cc}	-0.5		3.6	V
Storage Temperature	T _S	-40		85	°C
Operating Case Temperature	T _c	15	25	55	°C
Relative Humidity (non-condensing)	RH	5		85	%
Receiver Damage Threshold, each lane	P _{max}	3.5			dBm

Recommended Operating Conditions

Parameter	Symbol	Min.	Typ.	Max.	Unit
Operating Case Temperature	T _c	15	25	55	°C
Power Supply Voltage	V _{cc}	3.135	3.3	3.465	V
Power Dissipation	P _D			3.5	W
Total Data Rate			103.125		Gbps
Data Rate, each lane			25.78125		Gbps
Transmission Distance				0.5	km

Optical and Electrical Characteristics

Parameter	Symbol	Min.	Typ.	Max.	Unit	Notes	
Transmitter							
Bit Rate, each Lane		25.78125±100ppm			Gbps		
Line Wavelengths (Range)	CH0	λ_0	1264.5		1277.5	nm	
	CH1	λ_1	1284.5		1297.5	nm	
	CH2	λ_2	1304.5		1317.5	nm	
	CH3	λ_3	1324.5		1337.5	nm	
Side Mode Suppression Ratio	SMSR	30			dB		
Average Launch Power, each lane	P_{TX}	-6.5		2.5	dBm		
Transmitter Optical Modulation Amplitude (OMA), each lane	OMA	-4		2.5	dBm		
Extinction Ratio	ER	3.5			dB		
Average Launch Power of OFF Transmitter, each lane				-30	dBm		
Transmitter Reflectance				-12	dB		
Input Differential Impedance, each lane			100		Ω		
Transmitter Eye Mask Definition {X1, X2, X3, Y1, Y2, Y3}		{0.31, 0.4, 0.45, 0.34, 0.38, 0.4}				1	
Receiver							
Bit Rate, each Lane		25.78125±100ppm			Gbps		
Line wavelengths (range)	CH0	λ_0	1264.5		1277.5	nm	
	CH1	λ_1	1284.5		1297.5	nm	
	CH2	λ_2	1304.5		1317.5	nm	
	CH3	λ_3	1324.5		1337.5	nm	
Average receive power, each lane		-11.5		2.5	dBm		
Unstressed Receiver Sensitivity (OMA), each lane				-10	dBm	2	

Notes:

1. Eye mask hit ratio 5×10^{-5} .
2. Receiver sensitivity is informative. Measured with 25.78125Gb/s, PRBS31 NRZ, BER= 5×10^{-5} .

Pin Descriptions

Pin	Symbol	Name/Descriptions	Ref.
1	GND	Ground	1
2	Tx2n	Transmitter Inverted Data Input	
3	Tx2p	Transmitter Non-Inverted Data output	
4	GND	Ground	1
5	Tx4n	Transmitter Inverted Data Input	
6	Tx4p	Transmitter Non-Inverted Data output	
7	GND	Ground	1
8	ModSelL	Module Select	
9	ResetL	Module Reset	
10	VccRx	+3.3V Power Supply Receiver	2
11	SCL	2-Wire Serial Interface Clock	1
12	SDA	2-Wire Serial Interface Data	
13	GND	Ground	
14	Rx3p	Receiver Non-Inverted Data output	
15	Rx3n	Receiver Inverted Data output	
16	GND	Ground	1
17	Rx1p	Receiver Non-Inverted Data output	
18	Rx1n	Receiver Inverted Data output	
19	GND	Ground	1
20	GND	Ground	1
21	Rx2n	Receiver Inverted Data output	
22	Rx2p	Receiver Non-Inverted Data output	
23	GND	Ground	1
24	Rx4n	Receiver Inverted Data output	1
25	Rx4p	Receiver non-Inverted Data output	
26	GND	Ground	1
27	ModPrsL	Module Present	
28	IntL	Interrupt	
29	VccTx	+3.3V Power Supply Transmitter	2
30	VccI	+3.3V Power Supply	2
31	LPMODE	Low Power Mode	
32	GND	Ground	1
33	Tx3p	Transmitter Non-Inverted Data input	
34	Tx3n	Transmitter Inverted Data output	
35	GND	Ground	1
36	Tx1p	Transmitter Non-Inverted Data input	
37	Tx1n	Transmitter Inverted Data output	
38	GND	Ground	1

Notes:

1. GND is the symbol for signal and supply (power) common for QSPF28 modules. All are common within the QSPF28 module and all module voltages are referenced to this potential unless otherwise noted. Connected these directly to the host board signal common ground plane.
2. VccRx, Vcc1 and VccTx are the receiving and transmission power suppliers and shall be applied concurrently. VccRx, Vcc1 and VccTx may be internally connected within the QSPF28 transceiver module in any combination. The connector pins are each rated for a maximum current of 1000mA.

Electrical Pin-out Details

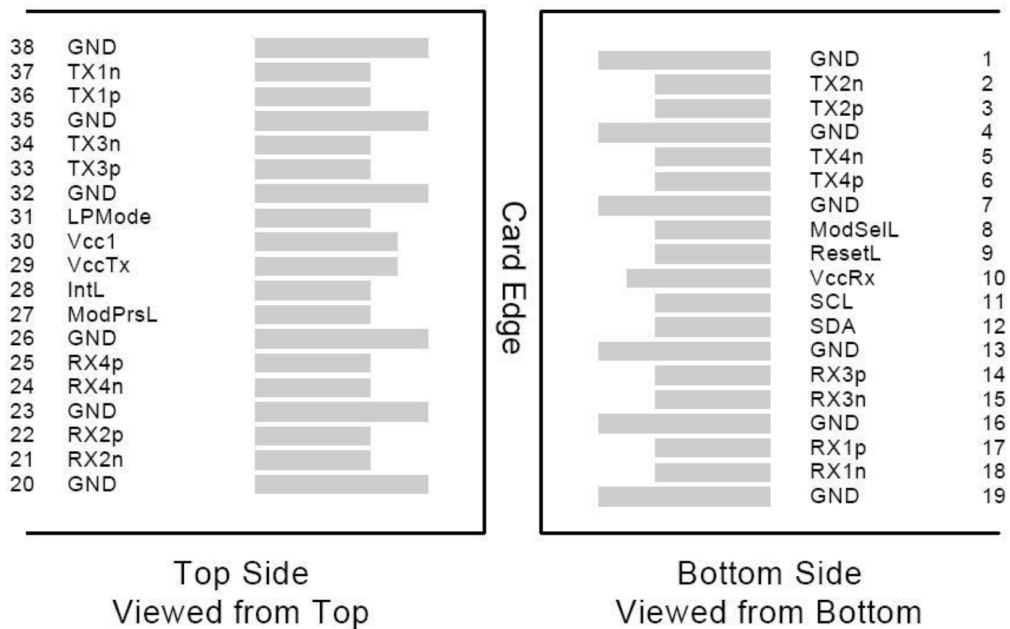

Digital Diagnostic Functions

Parameter	Symbol	Min.	Typ.	Max.	Unit	Notes
Temperature monitor absolute error	DMI_Temp	-3		3	°C	1
Supply voltage monitor absolute error	DMI_Vcc	-3%		3%	V	2
Bias current monitor absolute error	DMI_Ibias	-10%		10%	mA	
Laser power monitor absolute error	DMI_Tx	-3		3	dB	
RX power monitor absolute error	DMI_Rx	-3		3	dB	

Notes:

1. Over operating temperature
2. Over operating voltage

Recommended Interface Circuit

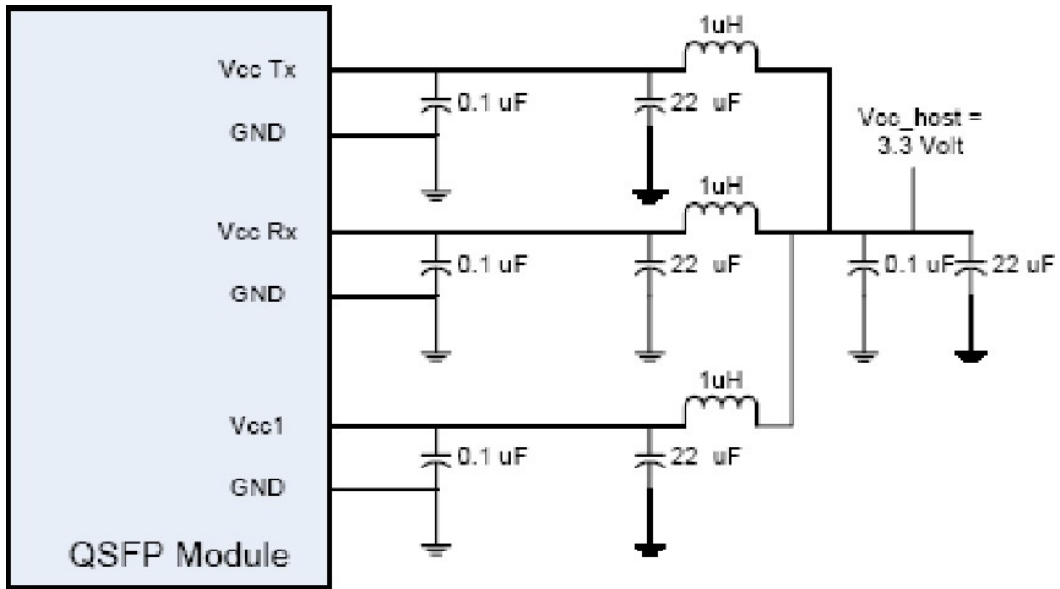

Mechanical Specifications

Measurement unit: mm

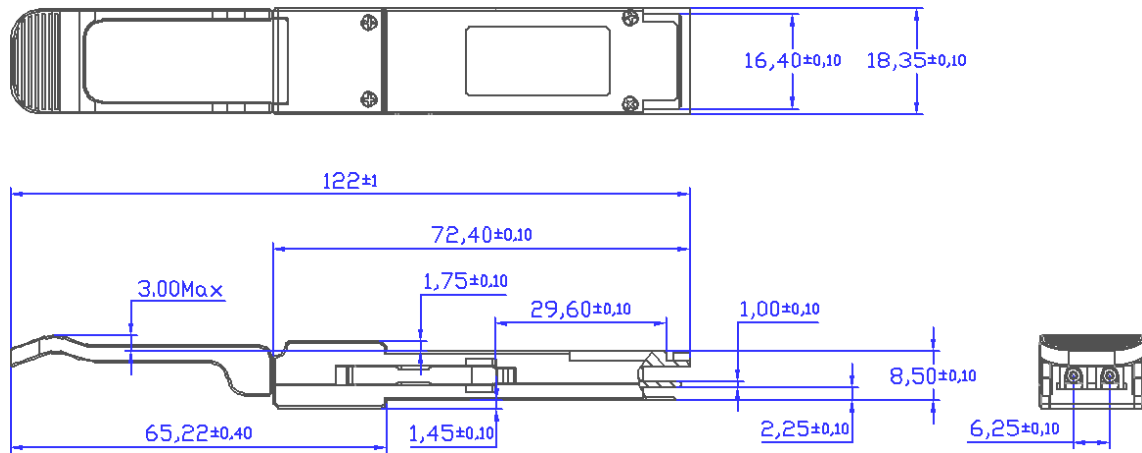

About AddOn Networks

In 1999, AddOn Networks entered the market with a single product. Our founders fulfilled a severe shortage for compatible, cost-effective optical transceivers that compete at the same performance levels as leading OEM manufacturers. Adhering to the idea of redefining service and product quality not previously had in the fiber optic networking industry, AddOn invested resources in solution design, production, fulfillment, and global support.

Combining one of the most extensive and stringent testing processes in the industry, an exceptional free tech support center, and a consistent roll-out of innovative technologies, AddOn has continually set industry standards of quality and reliability throughout its history.

Reliability is the cornerstone of any optical fiber network and is engrained in AddOn's DNA. It has played a key role in nurturing the long-term relationships developed over the years with customers. AddOn remains committed to exceeding industry standards with certifications from ranging from NEBS Level 3 to ISO 9001:2005 with every new development while maintaining the signature reliability of its products.

U.S. Headquarters

Email: sales@addonnetworks.com

Telephone: +1 877.292.1701

Fax: 949.266.9273

Europe Headquarters

Email: salesupportemea@addonnetworks.com

Telephone: +44 1285 842070