



# **FI-3000** **FiberInspector™ Pro**

## **Users Manual**



January 2019 Rev. 2, 2/2020

© 2019-2020 Fluke Corporation. All rights reserved.

Specifications are subject to change without notice.

All product names are trademarks of their respective companies.

## LIMITED WARRANTY AND LIMITATION OF LIABILITY

Each Fluke Networks product is warranted to be free from defects in material and workmanship under normal use and service unless stated otherwise herein. The warranty period for the mainframe is one year and begins on the date of purchase. Parts, accessories, product repairs and services are warranted for 90 days, unless otherwise stated. Ni-Cad, Ni-MH and Li-Ion batteries, cables or other peripherals are all considered parts or accessories. The warranty extends only to the original buyer or end user customer of a Fluke Networks authorized reseller, and does not apply to any product which, in Fluke Networks' opinion, has been misused, abused, altered, neglected, contaminated, or damaged by accident or abnormal conditions of operation or handling. Fluke Networks warrants that software will operate substantially in accordance with its functional specifications for 90 days and that it has been properly recorded on non-defective media. Fluke Networks does not warrant that software will be error free or operate without interruption.

Fluke Networks authorized resellers shall extend this warranty on new and unused products to end-user customers only but have no authority to extend a greater or different warranty on behalf of Fluke Networks. Warranty support is available only if product is purchased through a Fluke Networks authorized sales outlet or Buyer has paid the applicable international price. To the extent permitted by law, Fluke Networks reserves the right to invoice Buyer for repair/replacement when a product purchased in one country is submitted for repair in another country.

For a list of authorized resellers, visit [www.flukenetworks.com/wheretobuy](http://www.flukenetworks.com/wheretobuy).

Fluke Networks warranty obligation is limited, at Fluke Networks option, to refund of the purchase price, free of charge repair, or replacement of a defective product which is returned to a Fluke Networks authorized service center within the warranty period.

To obtain warranty service, contact your nearest Fluke Networks authorized service center to obtain return authorization information, then send the product to that service center, with a description of the difficulty, postage and insurance prepaid (FOB destination). Fluke Networks assumes no risk for damage in transit. Following warranty repair, the product will be returned to Buyer, transportation prepaid (FOB destination). If Fluke Networks determines that failure was caused by neglect, misuse, contamination, alteration, accident or abnormal condition of operation or handling, or normal wear and tear of mechanical components, Fluke Networks will provide an estimate of repair costs and obtain authorization before commencing the work. Following repair, the product will be returned to the Buyer transportation prepaid and the Buyer will be billed for the repair and return transportation charges (FOB Shipping point).

**THIS WARRANTY IS BUYER'S SOLE AND EXCLUSIVE REMEDY AND IS IN LIEU OF ALL OTHER WARRANTIES, EXPRESS OR IMPLIED, INCLUDING BUT NOT LIMITED TO ANY IMPLIED WARRANTY OF MERCHANTABILITY OR FITNESS FOR A PARTICULAR PURPOSE. FLUKE NETWORKS SHALL NOT BE LIABLE FOR ANY SPECIAL, INDIRECT, INCIDENTAL OR CONSEQUENTIAL DAMAGES OR LOSSES, INCLUDING LOSS OF DATA, ARISING FROM ANY CAUSE OR THEORY.**

Since some countries or states do not allow limitation of the term of an implied warranty, or exclusion or limitation of incidental or consequential damages, the limitations and exclusions of this warranty may not apply to every buyer. If any provision of this Warranty is held invalid or unenforceable by a court or other decision-maker of competent jurisdiction, such holding will not affect the validity or enforceability of any other provision.

4/15

Fluke Networks  
PO Box 777  
Everett, WA 98206-0777  
USA

# Table of Contents

Title	Page
Introduction .....	1
Safety Information.....	1
Symbols.....	2
Features of the Probe .....	3
LED Status Lights.....	4
Probe Setup.....	5
Single Fiber Tip Attachment.....	5
MPO Tip Attachment .....	6
MPO Key Position.....	6
Charge the Battery .....	8
The FI-IN app .....	9
Download and Connect to the App.....	9
Live View Screen .....	11
Main Menu .....	13
Set up or Edit a Project .....	13
Manage Projects.....	15
Focus Toolbar .....	15
Quick Access Toolbar .....	16
Do a FiberInspector Test.....	16
Results.....	17
View Endfaces .....	18
Image Tab.....	19
Defects Tab.....	20
Clean Endfaces .....	21
LinkWare™ PC Software .....	23
Download LinkWare PC Software.....	23
Update Firmware .....	23
Maintenance .....	24
Cleaning.....	24
Battery replacement .....	24
Learn More .....	25
Registration .....	25
Contact Fluke Networks .....	25
General Specifications .....	26



# Introduction

The FI-3000 FiberInspector™ Pro (the Product or Probe) is a hand-held video probe used with a Versiv™ Series tester or with the FI-IN™ app (the App) on a mobile device to inspect fiber optic endfaces on MPO or single fiber connectors. The Probe and Tester or App let you see dirt, scratches, and other defects that can cause unsatisfactory performance or failures in fiber optic networks.

The FI-3000 probe is included with the FI2-7300 kit (the Kit). The Probe is an optional accessory for the CertiFiber Pro and OptiFiber Pro Testers.

This manual explains how to use the Probe with the FI-IN app to view and analyze endfaces and save and share test results.

To use the Probe with a Versiv Series tester, see the *Versiv Users Manual* at [www.flukenetworks.com/support/manuals](http://www.flukenetworks.com/support/manuals).

# Safety Information

A **Warning** identifies hazardous conditions and procedures that are dangerous to the user. A **Caution** identifies conditions and procedures that can cause damage to the Product or the equipment under test.

## Warning

**To prevent possible electrical shock, fire, or personal injury and for safe operation of the Product:**









- Read all safety information before you use the Product.
- Carefully read all instructions.
- Do not alter the Product and use only as specified, or the protection supplied by the Product can be compromised.
- Do not use the Product if it operates incorrectly.
- Do not use the Product if it is altered or damaged.
- Disable the Product if it is damaged.
- Use only Fluke Network approved power adapters to supply power to the Product and charge the battery.
- Charge the battery indoors.

- If the Product gets hot, disconnect the battery charger and move the Product to a cool, non-flammable location.
- Replace the rechargeable battery after 5 years of moderate use or 2 years of heavy use. Moderate use is defined as recharged twice a week. Heavy use is defined as discharged to cutoff and recharged daily. To replace the battery, send the Product to an authorized Fluke Networks Service Center.
- Have an approved technician repair the Product.
- Do not open the case. You cannot repair or replace parts in the case.





## Symbols

Table 1 lists the symbols that may be used on the Product or in this document.

**Table 1. Symbols**

Symbol	Description
	Consult user documentation.
	WARNING. RISK OF DANGER.
	WARNING. HAZARDOUS VOLTAGE. Risk of electric shock.
	Conforms to European Union directives.
	Conforms to relevant Australian Safety and EMC standards.
	Certified by CSA Group to North American safety standards.
	Conforms to the Appliance Efficiency Regulation (California Code of Regulations, Title 20, Sections 1601 through 1608), for small battery charging systems.
	This Product contains a lithium-ion battery. Do not mix with the solid waste stream. Spent batteries should be disposed of by a qualified recycler or hazardous materials handler per local regulations. Contact your authorized Fluke Service Center for recycling information.
	This product complies with the WEEE Directive marking requirements. The affixed label indicates that you must not discard this electrical/electronic product in domestic household waste. Product Category: With reference to the equipment types in the WEEE Directive Annex I, this product is classed as category 9 "Monitoring and Control Instrumentation" product. Do not dispose of this product as unsorted municipal waste.

**Table 1. Symbols (cont.)**

Symbol	Description
	40 year Environment Friendly Use Period (EFUP) under China Regulation - Administrative Measure on the Control of Pollution Caused by Electronic Information Products. This is the period of time before any of the identified hazardous substances are likely to leak out, causing possible harm to health and the environment.
	Auto Focus
	Push to do a test.
	PortBright™ LED on/off
	On/Off

## Features of the Probe

Table 2 shows the features of the Probe.

**Table 2. Features of the Probe**





	
Item	Description
<b>1</b>	Dust cap.
<b>2</b>	PortBright™ LED.
<b>3</b>	Removable tip for different types of connectors.

Table 2. Features of the Probe (cont.)

Item	Description
4	Status LEDs. See <a href="#">LED Status Lights</a> .
5	 <b>(Auto Focus)</b> : With a live image on the display, push to automatically focus the image.
6	 <b>(Test)</b> : Push to analyze an endface image. Push again to return to the Live View screen.
7	 : Push for 2 seconds to turn on or off the Probe.
8	 : Push to turn on or off the PortBright™ LED.
9	USB type C port. Use with the USB cord or an approved AC adapter to charge the Probe. Use an AC adapter to charge the battery faster than with the USB cord connected to a PC or laptop.
10	Battery status LED.
11	USB cord (USB type A to USB type C).

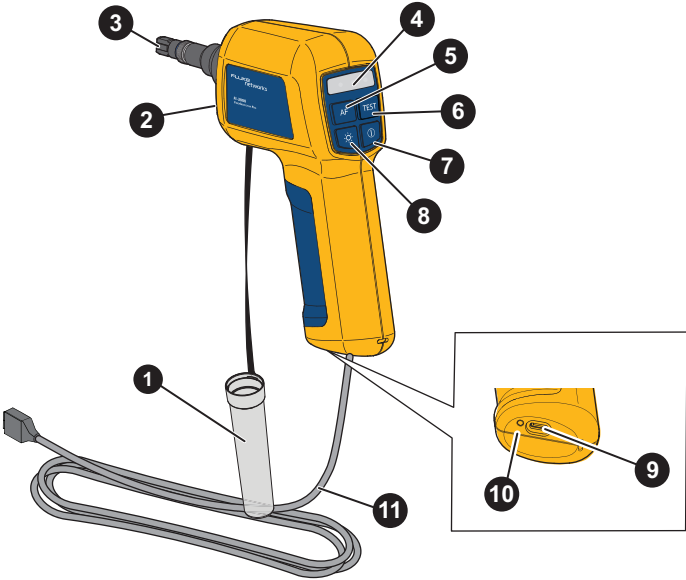
## LED Status Lights

Table 3 lists the functions of the status lights.

Table 3. LED Status Lights

Color	Description
Blue	<p><b>Two short blinks periodically</b>: The Probe is on, but it is not connected to a mobile device.</p> <p><b>One short blink periodically</b>: The Probe is connected to the mobile device, but the App is not active.</p> <p><b>Solid</b>: The Probe is connected to a mobile device and the App is active.</p>
Red	The test failed.
Green	The test passed.
Red and Green	<b>Test Limit</b> is set to <b>Document Only</b> , so the result does not have a <b>Pass</b> or <b>Fail</b> status.



# Probe Setup

To do a single fiber inspection, use the Probe with the single fiber adapter and the appropriate single fiber tip. To do an MPO inspection, use the Probe with the appropriate MPO tip and, if necessary, the appropriate MPO aligned or opposed key adapter.

### Note

*Features and instructions that refer to a key position only apply to MPO tests.*

## Single Fiber Tip Attachment

To attach the single fiber adapter and single fiber tip to the Probe:

1. Align the slot in the single fiber adapter with the alignment pin on the end of the Probe. See Figure 1.
2. Turn the silver ring on the Probe to secure the adapter to the Probe.
3. Align the slot in the single fiber tip with the alignment pin on the adapter.
4. Turn the ring on the adapter to secure the tip to the adapter.

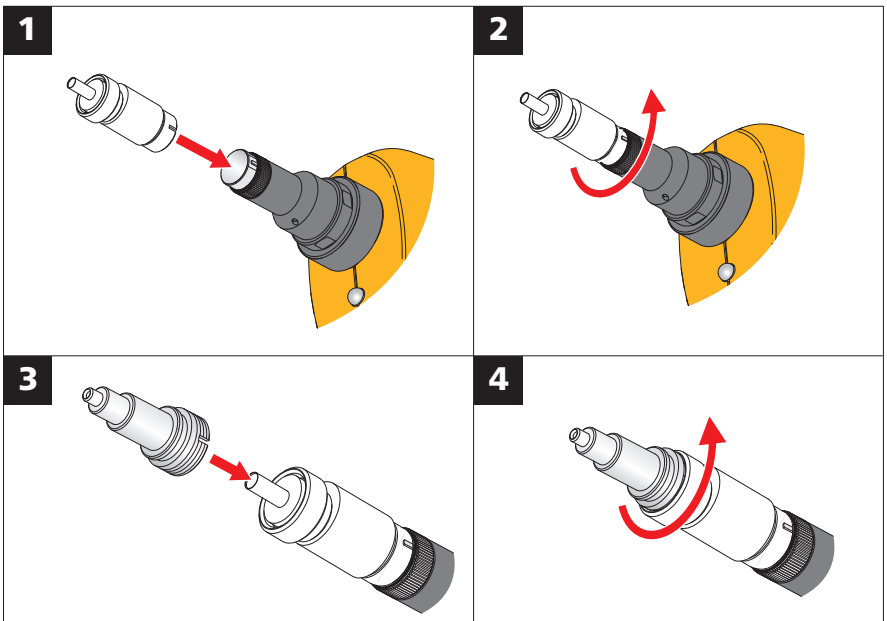

**Figure 1. Single Fiber Tip Attachment**

## MPO Tip Attachment

Attach the tip to the Probe with the key in the desired position. To learn more about key position, see [MPO Key Position](#).

To attach a tip:

1. Align the slot in the tip with the alignment pin on the end of the Probe. See Figure 2.
2. Turn the silver ring on the Probe to secure the tip to the Probe.

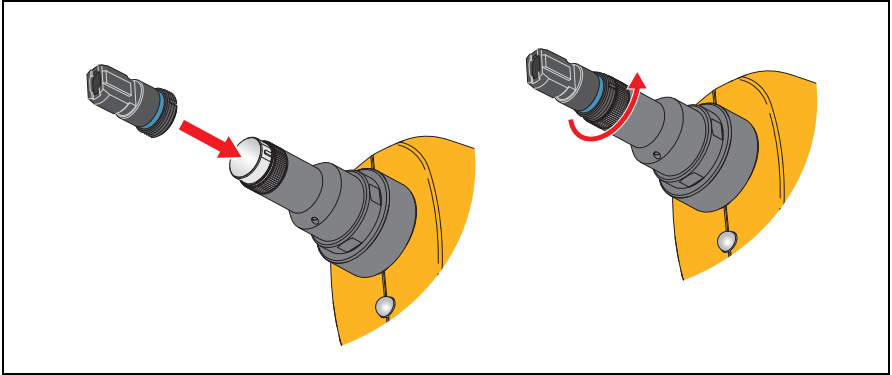

Figure 2. MPO Tip Attachment

## MPO Key Position

The tip has an MPO key that you can put on either the left or right side of the Probe. This lets you rotate the Probe when a cabinet door or other object prevents movement of the Probe. See Figure 3.

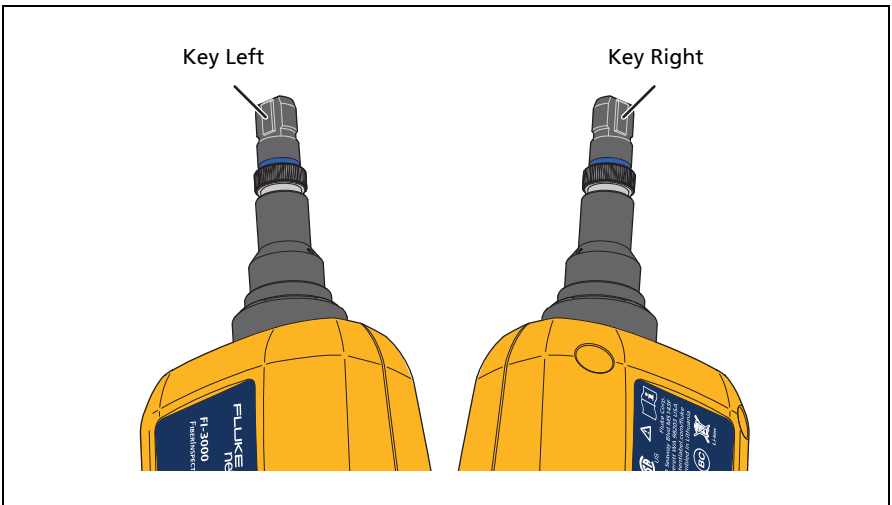

Figure 3. Key Position of the Tip

Set the **Key Position** in the App to make the fiber numbers on the image of the endface on the display agree with the fiber locations of the connector. This is called fiber number agreement. To set the key position, see [Table 9. Quick Access Toolbar](#).

The key position on an adapter affects the location of the fiber numbers on image of the test result.

With an adapter attached to the tip, to see the correct numbers for the fibers in the test results:

- For an opposed key adapter, set **Key Position** to the key position on the Probe.
- For an aligned key adapter, set **Key Position** to the opposite side from the key position used on the Probe.

With **Key Position** set correctly for the type of adapter, fiber number 1 shows on the top left of the image on the display.

*Note*

*If you rotate the adapter or tip on the probe, change the key position to **Key Left** or **Key Right**, as appropriate to maintain fiber number agreement.*

Figure 4 shows the key on the left side of the Probe and **Key Position** set to **Key Left** in the App to test connectors in a patch panel with opposed key adapters.

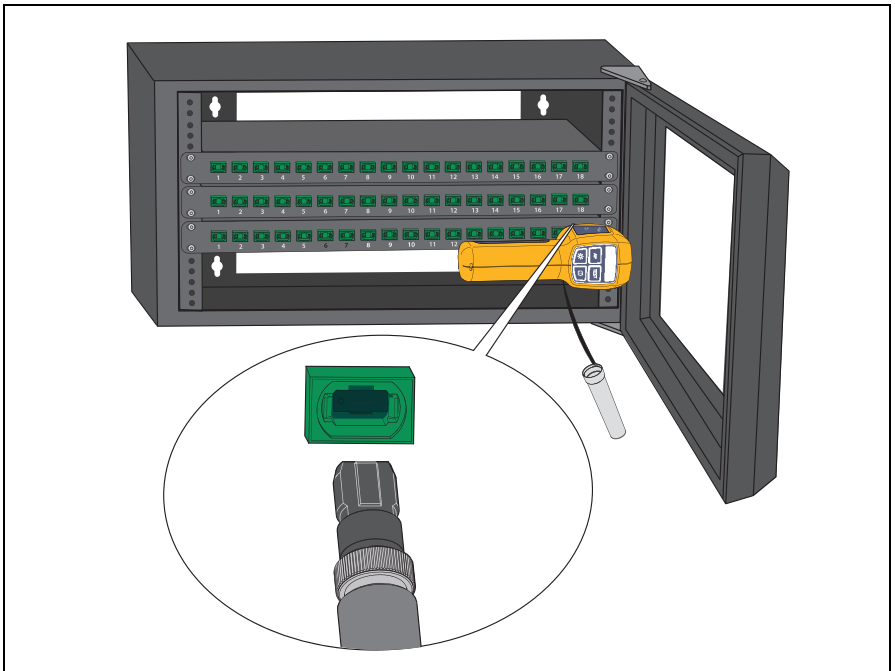

**Figure 4. Key Left Position with Opposed Key Adapter**

# Charge the Battery

Before you use the Probe for the first time, charge the battery for  $\geq 2$  hours with the Tester turned off. See Figure 5. The battery charges in  $\leq 5$  hours. A fully-charged battery operates for  $\geq 10$  hours of typical use.

### Note

*You do not need to fully discharge the battery before you recharge it.*

*The battery will not charge if its temperature is outside the range of 32 °F to 113 °F (0 °C to 45 °C) or if it has a fault and must be replaced.*

*With the Probe connected to an AC adapter and the Probe on, the Probe charges slower than with the Probe off.*

*When you send an image to the Tester, the battery uses more power than what the AC adapter supplies to charge the battery.*

The battery status LED shows red while the battery charges. The LED shows green to indicate the battery is fully-charged. The LED alternates between red and green to indicate that the battery will not charge.

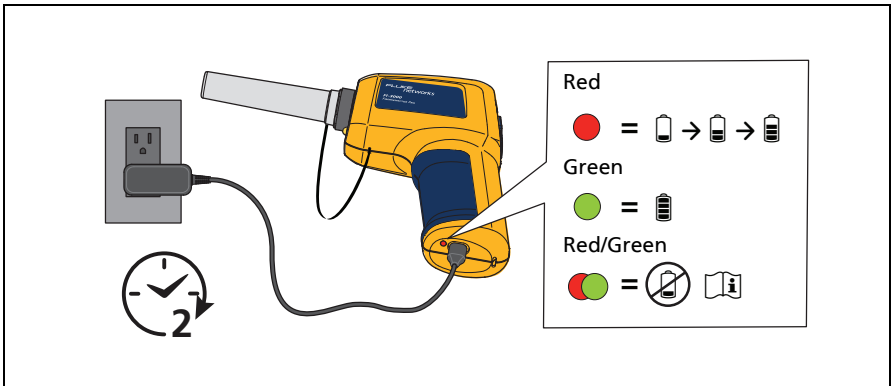

Figure 5. Charge the Battery

# The FI-IN app

The FI-IN app works with Apple® and Android™ products. The app is available for download from the Apple App Store® and Google Play™. You can use the App on smart phones or tablets.

## Note

*For a list of mobile devices that fully support the App, visit the Fluke Networks website.*

*The Probe cannot connect to a mobile device that has a VPN connection. If needed, disconnect the mobile device from the VPN connection.*

## Download and Connect to the App

To use the App with the Probe (See Figure 6.):

1. Download the App.
2. On the Probe, push  for  $\geq 2$  seconds.
3. On the mobile device:
  - a. Go to **Settings > Wi-Fi**.
  - b. Select the Wi-Fi network that begins with **FI-3000**.

## Note

*If your mobile device shows a message that there is no internet access, stay connected to the probe.*

4. Open the App.
5. In the Password field, enter 1234567890.

## Note

*The password is the same for all probes. You cannot change the password.*

Some mobile devices disconnect from the probe if you do not use the probe for several minutes.

To reconnect to WiFi from within the App:

1. Tap the WiFi Connection Indicator. See Figure 7 and Table 4.
2. Select the Wi-Fi network that begins with **FI-3000**.

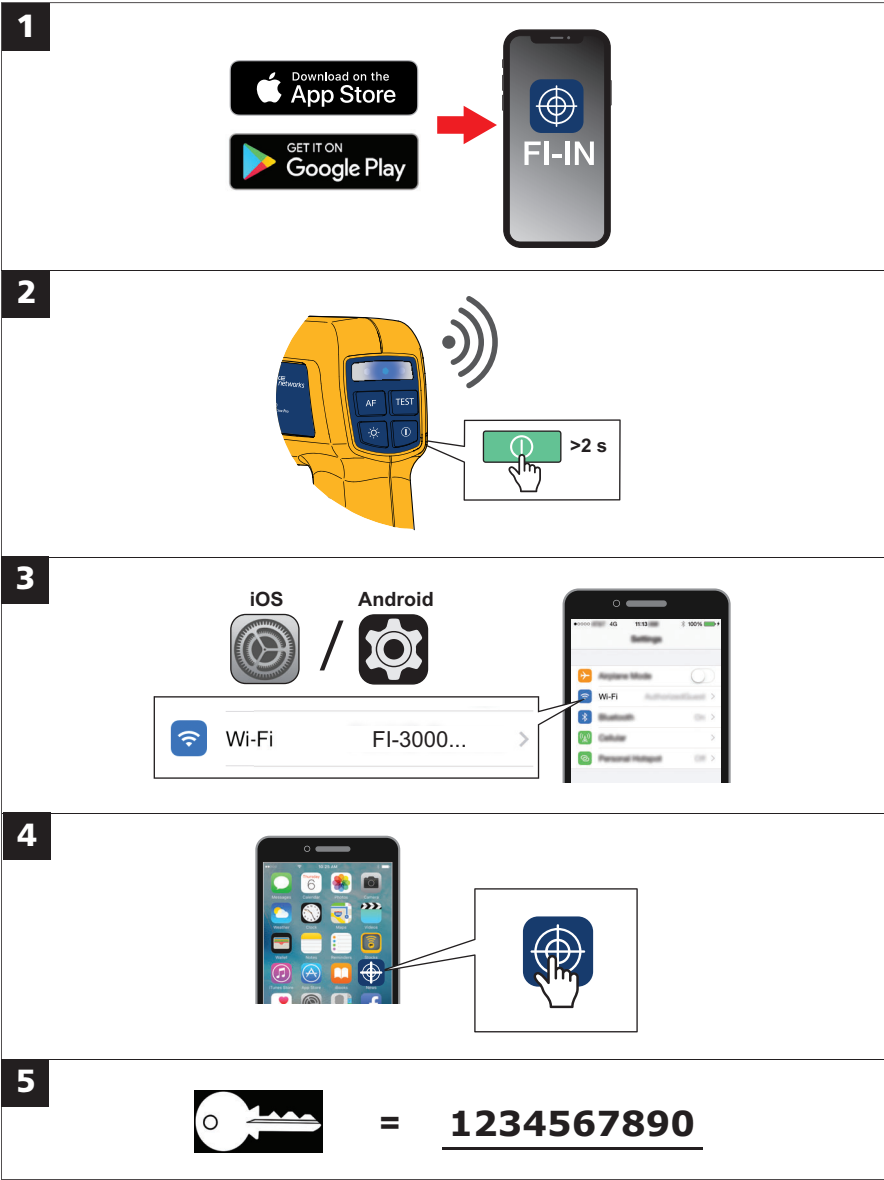

Figure 6. Download and Connect to the App

# Live View Screen

Figure 7 and Table 4 show the features on the Live View or home screen.

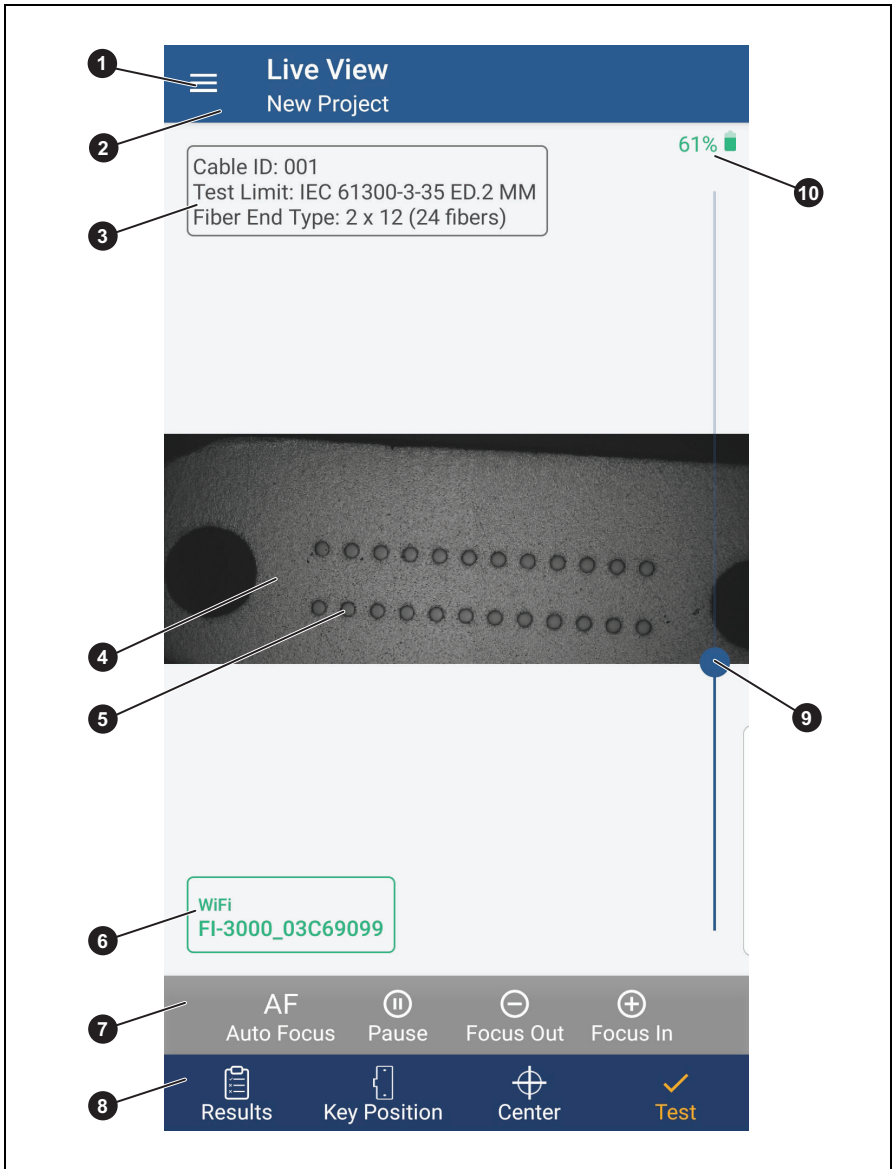





Figure 7. Live View Screen

**Table 4. Live View Screen**





Item	Description	Function
1	Menu button	Opens the main menu. See <a href="#">Main Menu</a> .
2	Project bar	Shows the project in use.
3	Project settings	Shows the <b>Cable ID</b> , <b>Test Limit</b> , and <b>Fiber End Type</b> settings.
4	Image of endface	Shows all of the fiber endfaces.  <i>Note</i>  <i>The image will be too dark to analyze if you use a UPC tip on the probe to inspect an APC endface.</i>
5	Individual endface	For MPO endfaces, shows one of the fiber endfaces.
6	WiFi connection indicator	Shows the WiFi connection status. Red: The Probe is not connected to a mobile device. Green: The Probe is connected to a mobile device. Orange: The image is paused. Push  to return to live mode.
7	Focus toolbar	Adjusts the focus and mode of the image. See <a href="#">Focus Toolbar</a> .
8	Quick access toolbar	Contains frequently used tools. See <a href="#">Quick Access Toolbar</a> .
9	Manual focus slider bar	Touch and slide the bar up or down to increase or decrease the focal distance to manually focus the image. To manually focus the image in fine increments, use  or  .
10	Battery status	Shows the battery status of the Probe.





# Main Menu

Use the Main menu to create and manage projects. Tap  to return to the previous menu. Table 5 lists the submenus available in the main menu.

**Table 5. Main Menu**

Item	Description	Function
	Current project	Opens the Edit Project menu to edit a project. See <a href="#">Set up or Edit a Project</a> .
	Manage Projects	Opens the Projects screen to add a new project or delete, edit, or copy a project. See <a href="#">Manage Projects</a> .
	Settings	Turn on or off Auto Focus before Test or set the language. With Auto Focus on, the Probe automatically focuses the image before a test runs.
	About	View information about the Probe and App.

## Set up or Edit a Project

Tap  >  to use the Edit Project menu to set up a project. You can set up a maximum of 100 projects. Table 6 lists the project settings.

**Table 6. Edit Project Menu**

Item	Description
Project Name	Enter a name for the project. A project name can have a maximum of 30 characters.
Operator	Enter the name of the technician. An operator name can have a maximum of 30 characters.





**Table 6. Edit Project Menu (cont.)**

Item	Description
Test Limit	<p><b>Document Only</b> is the default test limit and does not compare the results to standards or indicate pass or fail.</p> <p>Tap <input checked="" type="checkbox"/> to select a limit based on a standard.</p> <p>Limits for the test are from standards such as IEC 61300-3-35. The limits specify the maximum size and number of scratches and defects allowed in the core or cladding zones on the endface of the fiber.</p> <p>When you select a limit for the test, the App can compare the size, location, and number of scratches and defects to the criteria of the limit, and give each fault and the endface image a PASS or FAIL result.</p>
Select Fiber End Type	<p>Tap the image of the connector and select the end type with the correct number of fibers.</p>
Cable ID Set	<p>To create a list of sequential cable IDs, enter the <b>First ID</b> and <b>Last ID</b> for the list.</p> <p>When you save results, you can use the IDs sequentially, or you can select or create a different ID for a result.</p> <p>An ID can have a maximum of 60 characters.</p> <p>A project can have a maximum of 5000 IDs.</p> <p>Only alphanumeric characters increment.</p> <p>The characters in each position in the <b>First ID</b> and <b>Last ID</b> must have the same format:</p> <p>The IDs must be the same length.</p> <p>The characters in each position must be the same type (letters, numbers, or symbols).</p> <p>The characters in each position must be the same case.</p> <p>The IDs show in red text if the formats do not match.</p>

## Manage Projects

Use the Projects screen to create a new project or delete, edit, or copy a project. Table 7 lists the items on the Projects toolbar.





Table 7. Projects Toolbar

Item	Description
	Opens the <b>Add Project</b> menu to create a new project with default settings. See <a href="#">Set up or Edit a Project</a> .
	With a project selected <input checked="" type="checkbox"/> , deletes the project and the test results for the project. To delete multiple projects, select more than one project.
	With a project selected <input checked="" type="checkbox"/> , opens the <b>Edit Project</b> menu. See <a href="#">Set up or Edit a Project</a> .
	With a project selected <input checked="" type="checkbox"/> , opens the <b>Add Project</b> menu to create a new project from the settings of the selected project.

## Focus Toolbar

Use the Focus Toolbar to focus the image or toggle between live view and a still image. Table 8 lists the items on the Focus Toolbar.





Table 8. Focus Toolbar

Item	Description
AF	Automatically focuses the image.
	Pauses the live stream and shows a still image.
	Returns to live view mode.
	Manually reduces the focal distance in fine increments
	Manually increases the focal distance in fine increments

# Quick Access Toolbar

Use this toolbar to access frequently used tools. Table 9 lists the items on the Quick Access Toolbar.

Table 9. Quick Access Toolbar

Item	Description
	Opens the <b>Results</b> screen and toolbar.
	For MPO tests, opens the <b>Key Position</b> window to select <b>Key Left</b> or <b>Key Right</b> .
	Centers an image and returns it to the original size.
	Starts a test.



## Do a FiberInspector Test

To do the FiberInspector test:

1. Install the appropriate tip on the Probe. See [Probe Setup](#).
2. Connect the Probe to the mobile device. See [The FI-IN app](#).
3. Set up a Project. See [Set up or Edit a Project](#)
4. Clean the connector that you will inspect. See [Clean Endfaces](#).
5. Insert the probe into a connector or patch cord adapter. See [Figure 8](#).



Figure 8. Inspect an Endface (MPO shown)

6. Tap  (**Test**) in the App, or push  on the Probe to capture an image of the endface in the App.
7. If necessary, tap **AF (Auto Focus)** in the App, or push  on the Probe to focus the image.









The **TEST RESULT SUMMARY** screen shows on the display. For MPO tests, the screen shows an image of the connector, the test results, and the Results toolbar. For single fiber tests, the screen shows an image of the fiber endface, the test results, and the Results toolbar. Table 10 lists the items in the Results Toolbar.

8. To save the result:
  - a. Tap .
  - b. Select **End 1** or **End 2**.
  - c. Verify the **Cable ID** and **Project Folder** are correct.
  - d. Tap **Save**.

## Results

Use the Results screen and toolbar to view, delete, share, or rename results.

**Table 10. Results Toolbar**

Item	Description
	Returns to the <b>Live View</b> screen.
	Selects all of the results.
	With a result selected  , deletes the result.
	With a result selected  , sends an image or test report to an email recipient or social media account.
	Tap on the name of a result to see this feature to view the image of all the fiber endfaces.
	Tap on the name of the result to see this feature to change the name of a result.

# View Endfaces

## Note

*With Test Limit set to Document Only, not all features are available.*

To see an image of the endfaces:

1. On the **TEST RESULT SUMMARY** screen, if necessary, tap on the image of the connector to see a high-resolution image of the endfaces. See Figure 9. Use finger gestures to move or zoom the image.
2. If necessary, tap a fiber endface to see details about the defects on the endface.

The **IMAGE** tab shows the endface and any defects.

3. Tap the **DEFECTS** tab to see more details about the defects. See Table 11.

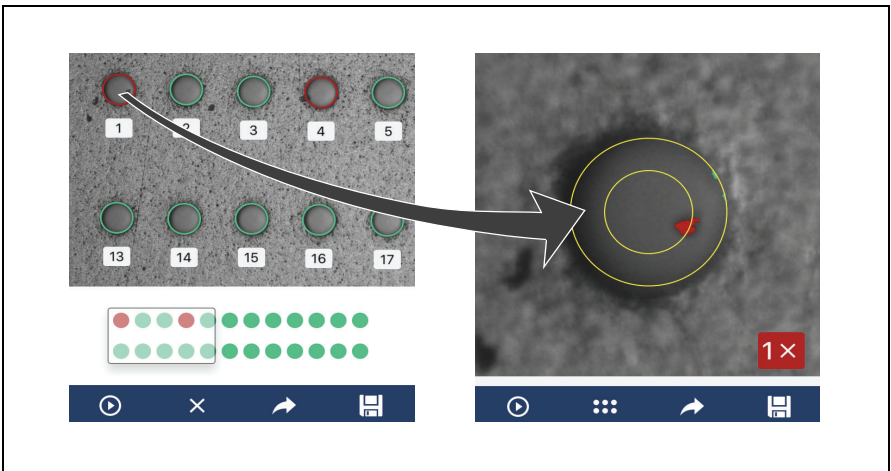

Figure 9. Image Analysis Screens (MPO shown)

## Image Tab

On the **IMAGE** tab, you can view the particles, scratches, and other defects.

Tap the image to see or hide the overlay that shows the yellow zone rings and the green (**PASS**) or red (**FAIL**) highlighted defects.

Pass/Fail Highlights:

- **Red: FAIL.** The scratch or defect is larger than the maximum size that the limit allows, is closer to the fiber core than the limit allows, or there are more scratches or defects than the limit allows.
- **Green: PASS.** The limit allows the scratch or defect because it is too small or too far from the core to cause problems, or there are fewer than the maximum allowed number of scratches or defects of that size.

### **Caution**

**If a defect is possibly a dirt particle, clean the endface and do the inspection again. You must remove all loose particles because they can move into the core when you make connections.**

Rings: On single fiber endfaces, the rings identify the core, cladding, adhesive, and contact zones. On MPO endfaces, the rings identify the core and cladding zones.

- The **Core** zone is the optical fiber. This area typically has a diameter of 9  $\mu\text{m}$  for singlemode fiber or 50  $\mu\text{m}$  or 62.5  $\mu\text{m}$  for multimode fiber.
- The **Cladding** zone is the area between the outer yellow ring and the **Core** zone. The cladding is a layer of reflective material around the core that keeps the optical signal in the core.
- The **Adhesive** zone is the ring of epoxy or glue that attaches the cladding to the ferrule. This is the zone between the two green rings on the FiberInspector image. The middle of this area has a diameter of 125  $\mu\text{m}$ , which is the diameter of the ferrule. Standards for endface analysis do not specify limits for scratches or defects in the adhesive zone, so defects and scratches in this area do not affect the **PASS/FAIL** result.
- The **Contact** zone is the area on the ferrule that touches the other fiber when you make a connection. The blue ring around the **Contact** zone has a diameter of 250  $\mu\text{m}$  for all limits.

## Defects Tab

The **DEFECTS** tab shows the number and size of the Scratches and Defects in and around the core of the fiber. Scratches and defects in zones that fail show in red. See Table 11.

On MPO endfaces, you can swipe the screen to scroll through the endfaces.

**Table 11. Defects Tab (Single Fiber shown)**

Item	Description
1	Zone A shows defects located in the core.
2	Zone B shows defects located in the cladding.
3	Zone D shows defects located in the contact zone.
4	There are no scratches in the zones greater than the allowable size or number.
5	This defect is green because the limit allows for a greater number of defects of this size or smaller in this zone.
6	This defect is red because there are a greater number of defects of this size than the limit allows in this zone.



## Clean Endfaces

Fluke Networks recommends that you use a mechanical cleaner such as the Quick Clean™ fiber endface cleaner. Figure 10 shows how to use a single fiber Quick Clean cleaner to clean single fiber endfaces. Figure 11 show how to use an MPO Quick Clean cleaner to clean MPO connectors. For more details, see the documentation included with the cleaner.

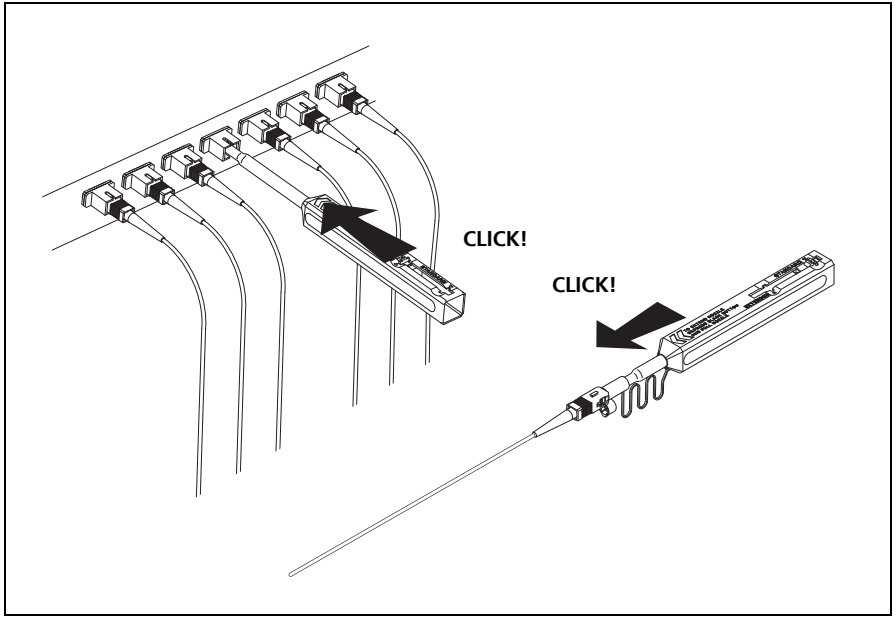

**Figure 10. Clean Single Fiber Endfaces**

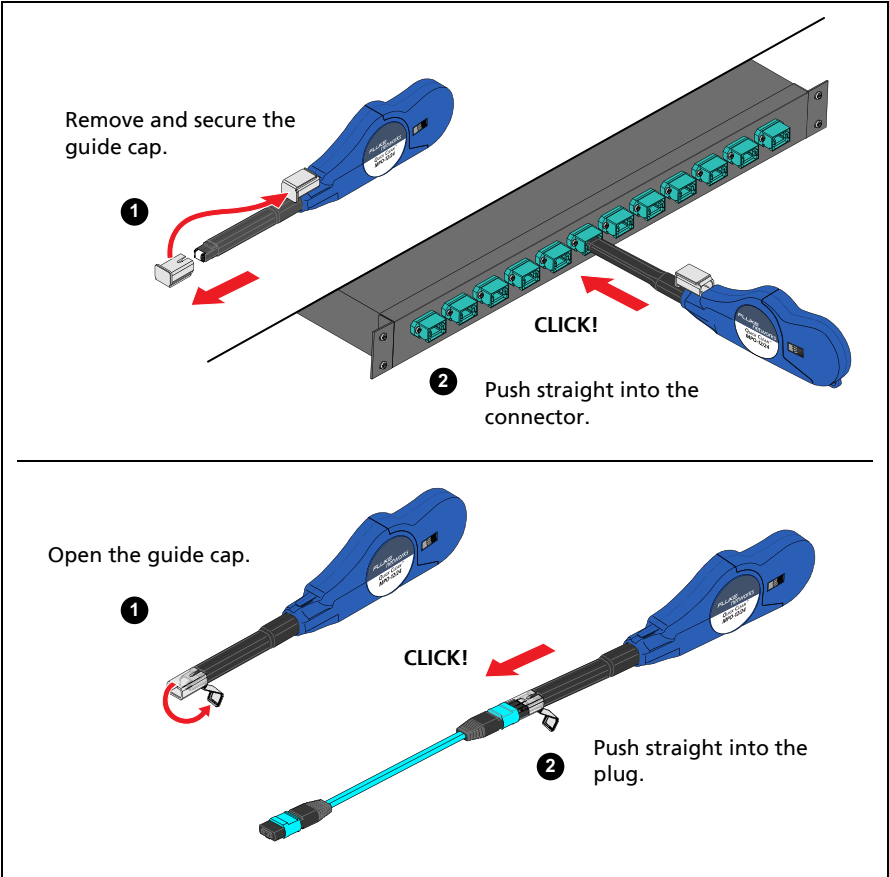

Figure 11. Clean MPO Endfaces

# LinkWare™ PC Software

Use LinkWare PC Cable Test Management Software to:

- Manage all the results from multiple tests with one PC application.
- Organize data and information.
- Make professional reports.
- Update the firmware with new features.

## Download LinkWare PC Software

To download LinkWare PC:

1. Go to <https://www.flukenetworks.com/support/downloads>.
2. On the website:
  - a. In the **Select a product** field, select LinkWare PC Cable Test Management Software and click **Go**.
  - b. Select the latest version of the software and follow the instructions to download the software to the PC.
3. On the PC, follow the instructions to install LinkWare PC software. (Administrator privileges are required for the installation.)
4. Restart the PC when installation is complete.

## Update Firmware

To update the firmware on the Probe:

1. If needed, download the latest version of LinkWare PC software.
2. On the PC, go to Go to <https://www.flukenetworks.com/support/downloads>.
3. On the website:
  - a. In the **Select a product** field, select the product name that starts with **FI-3000 FiberInspector Pro** and click **Go**.
  - b. Select the latest version of the software and follow the instructions to download the software to the PC.
4. On the PC:
  - a. Use File Explorer to navigate to the folder where you saved the download file.
  - b. Unzip the update file and locate the most recent .fip file.
  - c. Open LinkWare PC software.
5. Connect the USB C end of the USB cable to the Probe and the USB A end of the cable to the PC.

6. Push  on the Probe.

The blue light on the Probe flashes. Wait approximately 5 s to 10 s for the blue light to turn solid.

7. In LinkWare PC software:
  - a. Go to **Utilities > FI-3000 > Software Update**.
  - b. Navigate to the folder where you saved the .fip file and select the file.
  - c. Follow the directions on the screen to finish the update process.

*Note*

*If you have trouble with the update process, [Contact Fluke Networks](#).*

## Maintenance

### Warning

To prevent possible fire, electrical shock, or personal injury:

- Do not operate the Product with covers removed or the case open. Hazardous voltage exposure is possible.
- Do not open the case. You cannot repair or replace parts in the case.
- Use only specified replacement parts.
- Have an approved technician repair the Product.

## Cleaning

Clean the case with a soft cloth dampened with water or a mild soap. Do not use solvents or abrasive cleansers.

To clean the lens on the Probe, remove the tip then clean the lens with optical-grade cleaning supplies.

## Battery replacement

### Warning

To prevent possible fire, electrical shock, or personal injury:

- Replace the rechargeable battery after 5 years of moderate use or 2 years of heavy use. Moderate use is defined as recharged twice a week. Heavy use is defined as discharged to cutoff and recharged daily.
- To replace the battery, send the product to an authorized Fluke Networks Service Center.

## Learn More

To view, print, or download the latest manual or manual supplement, visit [www.flukenetworks.com/support/manuals](http://www.flukenetworks.com/support/manuals).

To read articles in the Knowledge Base, visit [www.flukenetworks.com/knowledge-base](http://www.flukenetworks.com/knowledge-base).

To request a printed manual, visit [www.fluke.com/productinfo](http://www.fluke.com/productinfo).

## Registration

Registering your product with Fluke Networks gives you access to valuable information on product updates, troubleshooting tips, and other support services.

To register the Probe:

1. Go to [www.flukenetworks.com](http://www.flukenetworks.com) and download the LinkWare PC software.
2. Do a test with the Probe and Tester and save the result.
3. Import the result into LinkWare PC software.
4. Follow the prompts in the software to register your product.

## Contact Fluke Networks



[www.flukenetworks.com/support](http://www.flukenetworks.com/support)



[info@flukenetworks.com](mailto:info@flukenetworks.com)



1-800-283-5853, +1-425-446-5500



Fluke Networks  
6920 Seaway Boulevard, MS 143F  
Everett WA 98203 USA

Fluke Networks operates in more than 50 countries worldwide. For more contact information, go to our website.

# General Specifications

Battery	Lithium-ion, 3.6 V, 6400 mAh
AC power adapter	
Input	100 VAC to 240 VAC $\pm$ 10 %, 50/60 Hz
Output	15 VDC, 2 A maximum, Class II
Temperature	
Operating	-10 °C to 45 °C (14 °F to 113 °F)
Storage	-10 °C to 60 °C (14 °F to 140 °F)
Charging	0 °C to 40 °C (32 °F to 104 °F)
Relative Humidity	
Operating	0 % to 95 % (32 °F to 95 °F, 0 °C to 35 °C) RH non-condensing
Storage	0 % to 95 % (95 °F to 113 °F, 35 °C to 45 °C) RH non-condensing
Altitude	
Operating	4000 m (3200 m with AC adapter)
Storage	12 000 m
Vibration and Shock	2 g, 5 Hz to 500 Hz, 30 g shock
Live image frame size	~1200 x 400, 10 fps
Live image field of view	
Low magnification	$\geq$ 4800 $\mu$ m x 1600 $\mu$ m
High magnification	680 $\mu$ m x 510 $\mu$ m
Auto focus time	$\leq$ 3 seconds
Connectors inspected	1 x 8 (8 fibers), 1 x 12 (8, 10, or 12 fibers), 1 x 16 (16 fibers), 2 x 12 (16, 20, or 24 fibers), 2 x 16 (32 fibers)
Test time	$<$ 2 seconds per fiber
Camera type	5 MP 1/4-inch CMOS sensor
Field of view	610 $\mu$ m x 460 $\mu$ m
Resolution	1 $\mu$ m
Light source	LED, $>$ 100 000 hour life
Endface illumination	Coaxial blue LED
PortBright illumination	White LED
Dimensions	168 mm x 137 mm x 54 mm (6.625 in x 5.375 in x 2.125 in) (with no dust cap or adapter tip) Length with dust cap: 191 mm (7.5 in)
Weight	326 g (11.5 oz) (with dust cap and no adapter tip)
Wireless radio	
Frequency	2400 MHz to 2483.5 MHz
Output power	$<$ 100 mW
For more information, go to <a href="http://www.flukenetworks.com/support/manuals">www.flukenetworks.com/support/manuals</a> , select the product name, then find <i>Radio Frequency Data for Class A</i> in the list of manuals.	

## Electromagnetic Compatibility (EMC)

International IEC 61326-1: Basic Electromagnetic Environment;  
CISPR 11: Group 1, Class A

*Group 1: Equipment has intentionally generated and/or uses conductively-coupled radio frequency energy that is necessary for the internal function of the equipment itself.*

*Class A: Equipment is suitable for use in all establishments other than domestic and those directly connected to a low-voltage power supply network that supplies buildings used for domestic purposes. There may be potential difficulties in ensuring electromagnetic compatibility in other environments due to conducted and radiated disturbances.*

*Caution: This equipment is not intended for use in residential environments and may not provide adequate protection to radio reception in such environments.*

Korea (KCC) Class A Equipment (Industrial Broadcasting & Communication Equipment)

*Class A: Equipment meets requirements for industrial electromagnetic wave equipment and the seller or user should take notice of it. This equipment is intended for use in business environments and not to be used in homes.*

USA (FCC) 47 CFR 15 Subpart C Sections 15.207, 15.209, 15.249

### SIMPLIFIED EU DECLARATION OF CONFORMITY

The simplified EU declaration of conformity referred to in Article 10(9) shall be provided as follows: Hereby, Fluke Networks declares that the radio equipment contained in this Product is in compliance with Directive 2014/53/EU. The full text of the EU declaration is available at the following internet address: <https://www.fluke.com/red>.