

## MC2309130-002-AO

Mellanox® MC2309130-002 Compatible TAA Compliant 10GBase-CU QSFP+ to SFP+ Direct Attach Cable (Passive Twinax, 2m)

### Features

- QSFP10 End: Compliant with QSFP+ MSA specifications
- SFP10 End: Compliant with SFP+ MSA specifications
- 1 independent duplex channels operating at 10Gbps
- support for 2.5Gbps, 5Gbps data rates
- AC coupled inputs and outputs
- 100Ω differential impedance
- 24 AWG Wire Gauge
- All-metal housing for superior EMI performance
- Single power supply 3.3V, low power consumption
- Operating Temperature: 0°C to 70°C
- ROHS Compliant



### Applications

- 10Gigabit Ethernet
- Serial Data Transmission
- Storage
- Fiber Channel
- Switch, Router

### Product Description

This is a Mellanox® MC2309130-002 compatible 10GBase-CU QSFP+ to SFP+ direct attach cable that operates over passive copper with a maximum reach of 2.0m (6.6ft). It has been programmed, uniquely serialized, and data-traffic and application tested to ensure it is 100% compliant and functional. This direct attach cable is TAA (Trade Agreements Act) compliant, and is built to comply with MSA (Multi-Source Agreement) standards. We stand behind the quality of our products and proudly offer a limited lifetime warranty.

AddOn's direct attach cables are RoHS compliant and lead free.

TAA refers to the Trade Agreements Act (19 U.S.C. & 2501-2581), which is intended to foster fair and open international trade. TAA requires that the U.S. Government may acquire only "U.S. – made or designated country end products."



## Regulatory Compliance

- ESD to the Electrical PINs: compatible with MIL-STD-883 Method 3015.
- ESD to the Duplex LC Receptacle: compatible with IEC 61000-4-2.
- Immunity: compatible with IEC 61000-4-3.
- EMI: compatible with FCC Part 15 Class B EN55022 Class B (CISPR 22B) VCCI Class B.
- Laser Eye Safety: compatible with FDA 21CFR 1040.10 and 1040.11 EN60950, EN (IEC) 60825-1, 2.
- RoHS: compliant with 2002/95/EC 4.1&4.2 2005/747/EC.

## General Specifications

Parameter	Symbol	Min.	Typ.	Max.	Unit	Notes
Storage Ambient Temperature	Tstg	-40		85	°C	
Operating Case Temperature	Tc	0		70	°C	
Input Voltage	Vcc	3.14	3.3	3.47	V	
Bit Error Rate	BER			10 <sup>-12</sup>		

## Cable Specifications

Parameter	Symbol	Min.	Typ.	Max.	Unit	Notes
Wire Gauge				24AWG	AWG	
Cable Impedance	Z	90	100	110	Ω	
24AWG Product Weight	G <sub>D24</sub>		115		g/PCS	1
24AWG Cable Weight	G <sub>C24</sub>		50		g/M	2
SFP10 END Dust Cap Weight	G <sub>S</sub>		0.80		g/PCS	
QSFP10 END Dust Cap Weight	G <sub>Q</sub>		1.40		g/PCS	

### Notes:

1. The weight of the cable including the SFP10 END and the QSFP10 END.
2. The weight of unit length cable.

## Cable Dimension and Nominal Length

Standard WireGauge AWG	Cable Diameter OD (mm)	Minimum BendingRadius R (mm)	Module Nominal Length L1 (cm)	Tolerance Range ±(cm)
24	6.0	28	4<L1	6

**Electrical Pad Layout (QSFP+ END)**

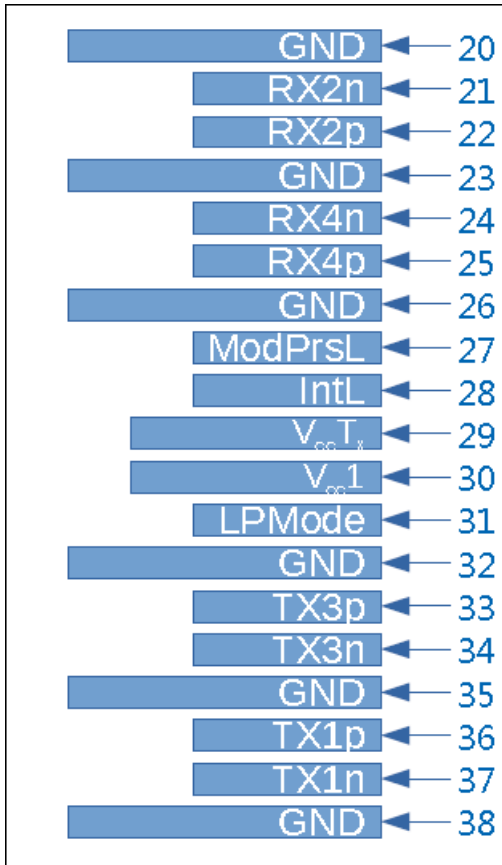

Top of Board

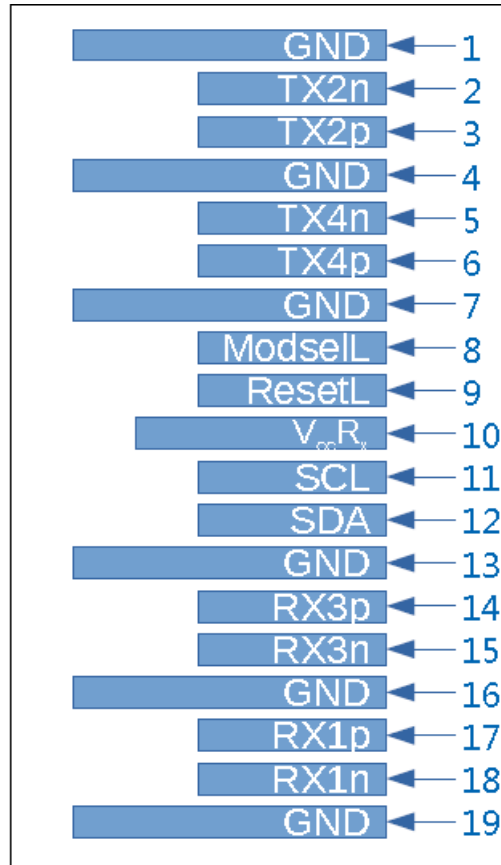

Bottom of Board

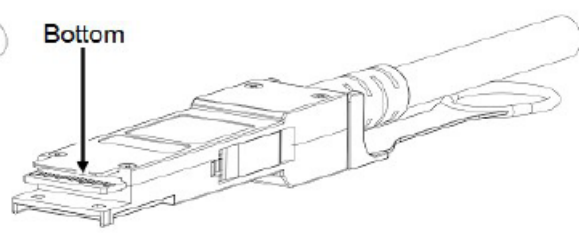
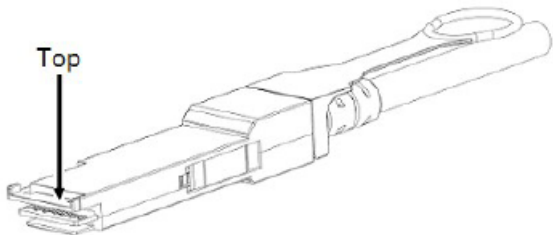

### Electrical Pad Layout (SFP+ END)

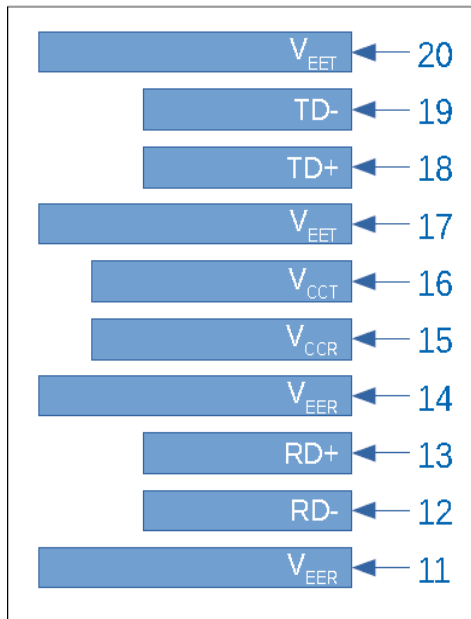

Top of Board

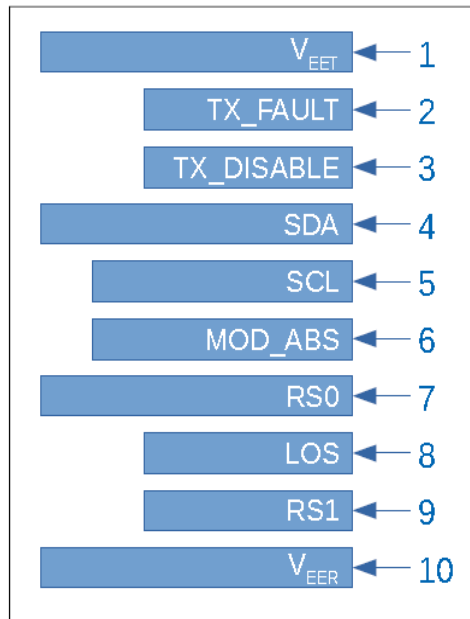
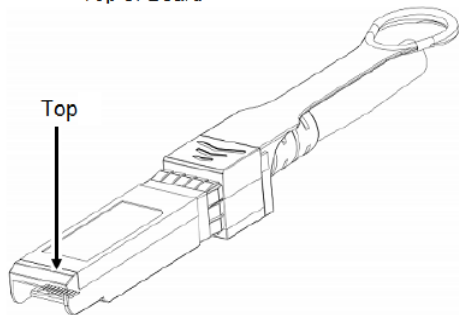

Bottom of Board

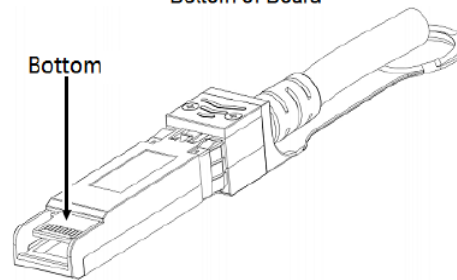

## Pin Descriptions (QSFP+ END)

Pin	Symbol	Descriptions	Notes
1	GND	Module Ground.	5
2	Tx2-	Transmitter Inverted Data Input. LAN2.	
3	Tx2+	Transmitter Non-Inverted Data Input. LAN2.	
4	GND	Module Ground.	5
5	Tx4-	Transmitter Inverted Data Input. LAN4.	
6	Tx4+	Transmitter Non-Inverted Data Input. LAN4.	
7	GND	Module Ground.	5
8	ModSelL	Module Select Pin. The module responds to 2-wire serial communication when low level.	1
9	ResetL	Module Reset.	2
10	VccRx	+3.3V Power Supply Receiver.	
11	SCL	2-Wire Serial Interface Clock.	
12	SDA	2-Wire Serial Interface Data.	
13	GND	Module Ground.	5
14	Rx3+	Receiver Non-Inverted Data Output. LAN3.	
15	Rx3-	Receiver Inverted Data Output. LAN3.	
16	GND	Module Ground.	5
17	Rx1+	Receiver Non-Inverted Data Output. LAN1.	
18	Rx1-	Receiver Inverted Data Output. LAN1.	
19	GND	Module Ground.	5
20	GND	Module Ground.	5
21	Rx2-	Receiver Inverted Data Output. LAN2.	
22	Rx2+	Receiver Non-Inverted Data Output. LAN2.	
23	GND	Module Ground.	5
24	Rx4-	Receiver Inverted Data Output. LAN4.	
25	Rx4+	Receiver Non-Inverted Data Output. LAN4.	
26	GND	Module Ground.	5
27	ModPrsL	The module is inserted into the indicate pin and grounded within the module.	3
28	IntL	Interrupt.	4
29	VccTx	+3.3V Power Supply Transmitter.	
30	Vcc1	+3.3V Power Supply.	
31	LPMode	Low-Power Mode.	5
32	GND	Module Ground.	5
33	Tx3+	Transmitter Non-Inverted Data Input. LAN3.	
34	Tx3-	Transmitter Inverted Data Input. LAN3.	
35	GND	Module Ground.	5
36	Tx1+	Transmitter Non-Inverted Data Input. LAN1.	
37	Tx1-	Transmitter Inverted Data Input. LAN1.	
38	GND	Module Ground.	5

**Notes:**

1. ModSelL is the input pin. The module responds to 2-wire serial communication commands when it is held "low" by the host. ModSelL allows multiple QSFP modules to be used on a single 2-wire interface bus. If ModSelL is "High," the module will not respond to any 2-wire interface communication from the host. ModSelL has internal pull-up resistors in the module.
2. The module restart pin, when the low level on the ResetL pin lasts longer than the minimum pulse length, resets the module and restores all user modules to their default state. When performing reset device, the host should ignore all status bits. Until the module reset interrupt is completed, please note that during hot plugging, the module will issue this information to complete the reset interrupt without resetting.
3. This pin is active high, indicating that the module is running under a low-power module. The signal has no effect on the functionality of this product.
4. IntL is the output pin, which is the open collector output and must be pulled up to Vcc with a 4.7k $\Omega$ -10k $\Omega$  resistor on the motherboard. When it is low, it indicates that the module may malfunction. The host uses a 2-wire serial interface to identify the interrupt source.
5. Circuit ground is internally isolated from the chassis ground.

## Pin Descriptions (SFP+ END)

Pin	Symbol	Descriptions	Notes
1	VeeT	Transmitter Ground (Common with Receiver Ground).	1
2	Tx_Fault	Transmitter Fault.	
3	Tx_Disable	Transmitter Disable. Laser output disabled on "high" or "open."	
4	SDA	Data line for 2-Wire Serial Interface ID.	2
5	SCL	Clock line for 2-Wire Serial Interface ID.	2
6	MOD_ABS	Module Absent. Grounded within the module.	2
7	RS0	No Connection Required.	
8	LOS	Loss of Signal Indication. "Logic 0" indicates normal operation.	
9	RS1	No Connection Required.	
10	VeeR	Receiver Ground (Common with Transmitter Ground).	1
11	VeeR	Receiver Ground (Common with Transmitter Ground).	1
12	RD-	Receiver Inverted Data Out. AC Coupled.	
13	RD+	Receiver Non-Inverted Data Out. AC Coupled.	
14	VeeR	Receiver Ground (Common with Transmitter Ground).	1
15	VccR	Receiver Power Supply.	
16	VccT	Transmitter Power Supply.	
17	VeeT	Transmitter Ground (Common with Receiver Ground).	1
18	TD+	Transmitter Non-Inverted Data In. AC Coupled.	
19	TD-	Transmitter Inverted Data In. AC Coupled.	
20	VeeT	Transmitter Ground (Common with Receiver Ground).	1

### Notes:

1. Circuit ground is isolated from the chassis ground.
2. Should be pulled up with 4.7kΩ-10kΩ resistor on the host board to a voltage between 2V and 3.6V.

# Mechanical Specifications

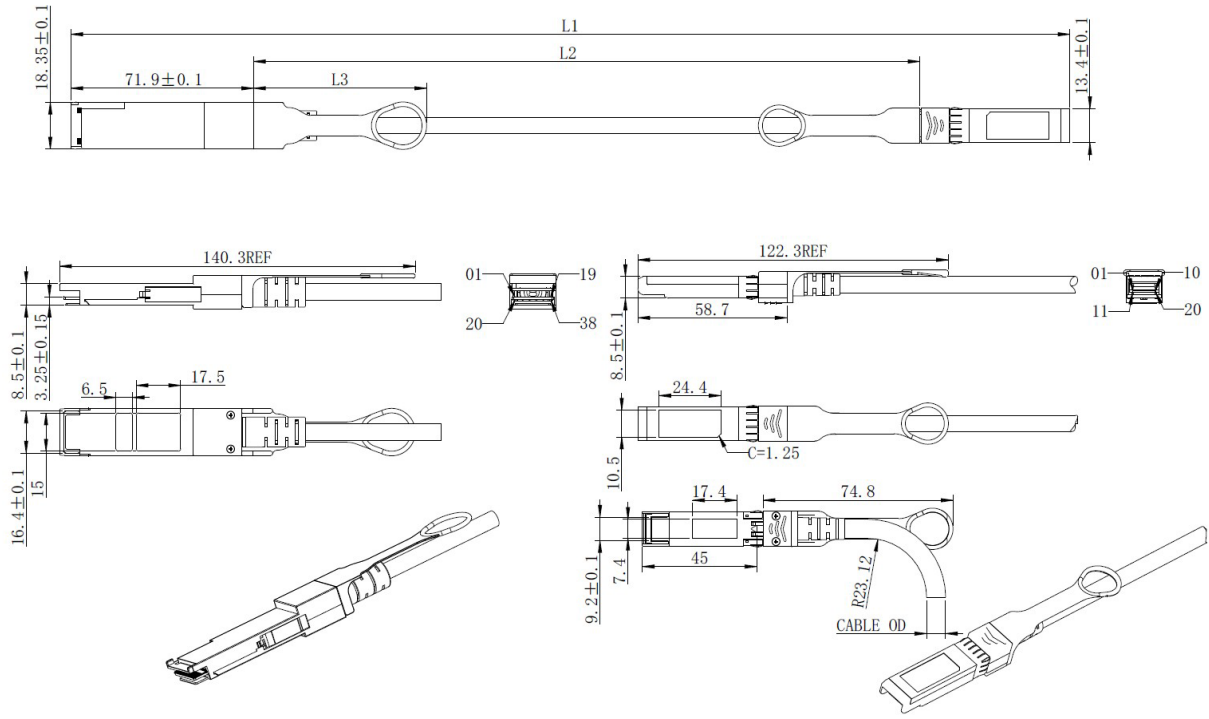



## **About AddOn Networks**

In 1999, AddOn Networks entered the market with a single product. Our founders fulfilled a severe shortage for compatible, cost-effective optical transceivers that compete at the same performance levels as leading OEM manufacturers. Adhering to the idea of redefining service and product quality not previously had in the fiber optic networking industry, AddOn invested resources in solution design, production, fulfillment, and global support.

Combining one of the most extensive and stringent testing processes in the industry, an exceptional free tech support center, and a consistent roll-out of innovative technologies, AddOn has continually set industry standards of quality and reliability throughout its history.

Reliability is the cornerstone of any optical fiber network and is engrained in AddOn's DNA. It has played a key role in nurturing the long-term relationships developed over the years with customers. AddOn remains committed to exceeding industry standards with certifications from ranging from NEBS Level 3 to ISO 9001:2005 with every new development while maintaining the signature reliability of its products.

## **U.S. Headquarters**

Email: [sales@addonnetworks.com](mailto:sales@addonnetworks.com)

Telephone: +1 877.292.1701

Fax: 949.266.9273

## **Europe Headquarters**

Email: [salesupportemea@addonnetworks.com](mailto:salesupportemea@addonnetworks.com)

Telephone: +44 1285 842070