

463-6740-AO

Dell® 463-6740 Compatible TAA 100Base-FX SFP Transceiver (MMF, 1310nm, 2km, LC, DOM)

Features

- INF-8074 and SFF-8472 Compliance
- Duplex LC Connector
- Commercial Temperature 0 to 70 Celsius
- Multi-mode Fiber
- Hot Pluggable
- Excellent ESD Protection
- Metal with Lower EMI
- RoHS Compliant and Lead Free



Applications

- 100Base Ethernet
- Access and Enterprise

Product Description

This Dell® 463-6740 compatible SFP transceiver provides 100Base-FX throughput up to 2km over multi-mode fiber (MMF) using a wavelength of 1310nm via an LC connector. It is guaranteed to be 100% compatible with the equivalent Dell® transceiver. This easy to install, hot swappable transceiver has been programmed, uniquely serialized and data-traffic and application tested to ensure that it will initialize and perform identically. Digital optical monitoring (DOM) support is also present to allow access to real-time operating parameters. This transceiver is Trade Agreements Act (TAA) compliant. We stand behind the quality of our products and proudly offer a limited lifetime warranty.

AddOn's transceivers are RoHS compliant and lead-free.

TAA refers to the Trade Agreements Act (19 U.S.C. & 2501-2581), which is intended to foster fair and open international trade. TAA requires that the U.S. Government may acquire only "U.S. – made or designated country end products."



Absolute Maximum Ratings

Parameter	Symbol	Min.	Typ.	Max.	Unit
Maximum Supply Voltage	V _{CC}	-0.5		3.6	V
Storage Temperature	T _{stg}	-40		85	°C
Operating Case Temperature	T _c	0		70	°C
Operating Humidity	RH			95	%
Receiver Power	R _{MAX}			-12	dBm
Data Rate			100/155		Mbps
50µm Core Diameter MMF	L		2		km

Electrical Characteristics

Parameter	Symbol	Min.	Typ.	Max.	Unit	Notes
Power Supply Voltage	V _{CC}	3.15	3.30	3.45	V	
Power Supply Current	I _{CC}			300	mA	
Transmitter						
LVPECL Differential Inputs	V _{IN}	400		2000	mVp-p	1
Input Differential Impedance	Z _{IN}	85	100	120	Ω	2
Tx_Disable	Disable		2	V _{CC}	V	
	Enable		0	0.8	V	
Tx_Fault	Fault		2	V _{CC} +0.3	V	
	Normal		0	0.5	V	
Receiver						
LVPECL Differential Outputs	V _{OUT}	400		2000	mVp-p	1
Output Differential Impedance	Z _{IN}	85	100	120	Ω	
Tx_Disable Assert Time	T _{off}			10	us	
Rx_LOS	LOS		2	V _{CC} +0.3	V	
	Normal		0	0.8	V	
MOD_DEF (0.2)	VOH	2.5			V	3
	VOL	0		0.8	V	3

Notes:

1. AC Coupled.
2. R_{IN} > 100kΩ @ DC.
3. With Serial ID.

Optical Characteristics

Parameter	Symbol	Min.	Typ.	Max.	Unit	Notes
Transmitter						
Average Output Power	POUT	-19		-14	dBm	1
Optical Extinction Ratio	ER	10			dB	2
Optical Wavelength	$T\lambda$	1260	1310	1360	nm	
Spectral Width (RMS)	$\Delta\lambda$			4	nm	
Total Jitter	TJ			1	ns	2
Tx_Disable Asserted Time	T_off			10	us	
POUT @ Tx_Disable Asserted	POUT			-45	dBm	
Rise/Fall Time (20-80%)	T_r/T_f			2	ns	
Output Optical Eye		IUT-T G.957 Compliant				
Receiver						
Receiver Sensitivity	P_{min}			-31	dBm	3
Receiver Overload	P_{max}	-12			dBm	
Optical Center Wavelength	λ_C	1260		1600	nm	
Return Loss		14			dB	

Notes:

1. Output power is measured by coupling into a 50/125mm multi-mode fiber.
2. Filtered. Measured with a PRBS $2^{23}-1$ test pattern @155Mbps.
3. Minimum average optical power is measured at BER less than $1E^{-12}$ with $2^{23}-1$ PRBS and ER=9dB.

Pin Descriptions

Pin	Symbol	Name/Description	Note
1	VeeT	Transmitter Ground. Common with Receiver Ground.	1
2	Tx_Fault	Transmitter Fault. LVTTTL-O.	2
3	Tx_Disable	Transmitter Disable. Laser output disabled on "high" or "open." LVTTTL-I.	3
4	SDA	2-Wire Serial Interface Data (Same as MOD-DEF2 in INF-8074i). LVTTTL-I/O.	
5	SCL	2-Wire Serial Interface Clock (Same as MOD-DEF2 in INF-8074i). LVTTTL-I.	
6	MOD_ABS	Module Absent. Connect to VeeT or VeeR in the module.	4
7	RS0	Rate Select 0. Not Used.	5
8	LOS	Loss of Signal indication. Logic 0 indicates normal operation. LVTTTL-O.	2
9	RS1	Rate Select 1. Not Used.	5
10	VeeR	Receiver Ground. Common with Transmitter Ground.	1
11	VeeR	Receiver Ground. Common with Transmitter Ground.	1
12	RD-	Receiver Inverted Data Out. AC Coupled. CML-O.	
13	RD+	Receiver Non-Inverted Data Out. AC Coupled. CML-O.	
14	VeeR	Receiver Ground. Common with Transmitter Ground.	1
15	VccR	Receiver Power Supply.	
16	VccT	Transmitter Power Supply.	
17	VeeT	Transmitter Ground. Common with Receiver Ground.	1
18	TD+	Transmitter Non-Inverted Data In. AC Coupled. CML-I.	
19	TD-	Transmitter Inverted Data In. AC Coupled. CML-O.	
20	VeeT	Transmitter Ground. Common with Receiver Ground.	1

Notes:

1. The module signal ground contacts, VeeR and VeeT, should be isolated from the module case.
2. This contact is an open collector/drain output and should be pulled up to the Host_Vcc with a resistor in the range 4.7kΩ-10kΩ. Pull-ups can be connected to one or several power supplies; however, the host board design shall ensure that no module contact has a voltage exceeding the module $V_{ccT}/R+0.5V$.
3. Tx_Disable is an input contact with a 4.7kΩ-10kΩ pull-up resistor to the VccT inside the module.
4. MOD_ABS is connected to the VeeT or VeeR in the SFP+ module. The host may pull the contact up to the Host_Vcc with a resistor in the range from 4.7kΩ-10kΩ. MOD_ABS is asserted "high" when the SFP+ module is physically absent from a host slot.
5. Internally pulled down per SFF-8431.

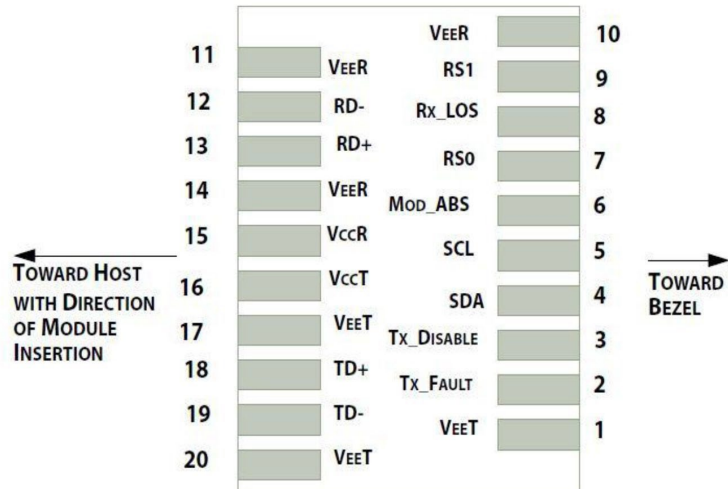

Pin-Out of Connector Block on the Host Board

Recommended Circuit Schematic

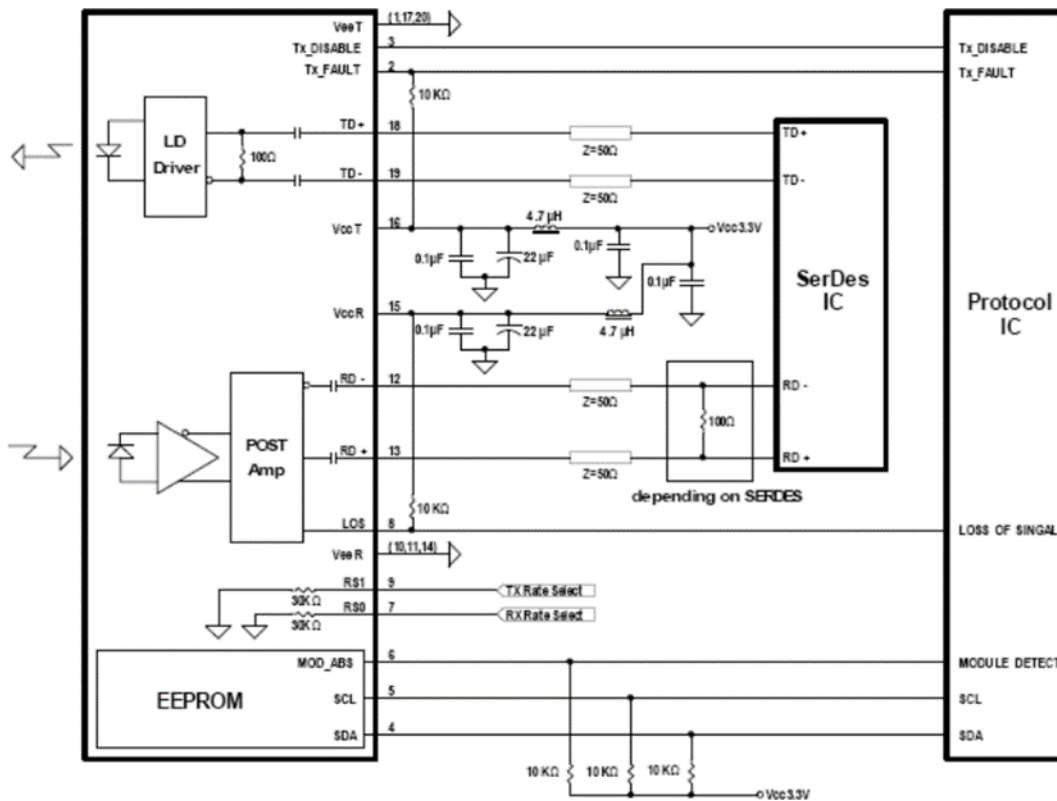

Mechanical Specifications

Small Form Factor Pluggable (SFP) transceivers are compatible with the dimensions defined by the SFP Multi- Sourcing Agreement (MSA).

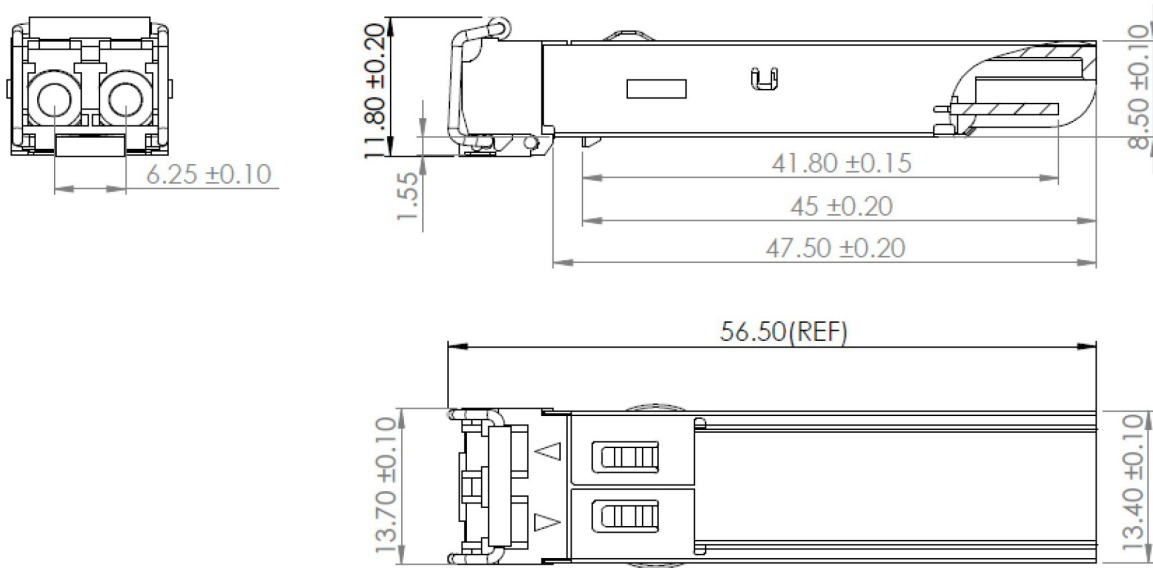

EEPROM Information

EEPROM memory map-specific data field description is as below:

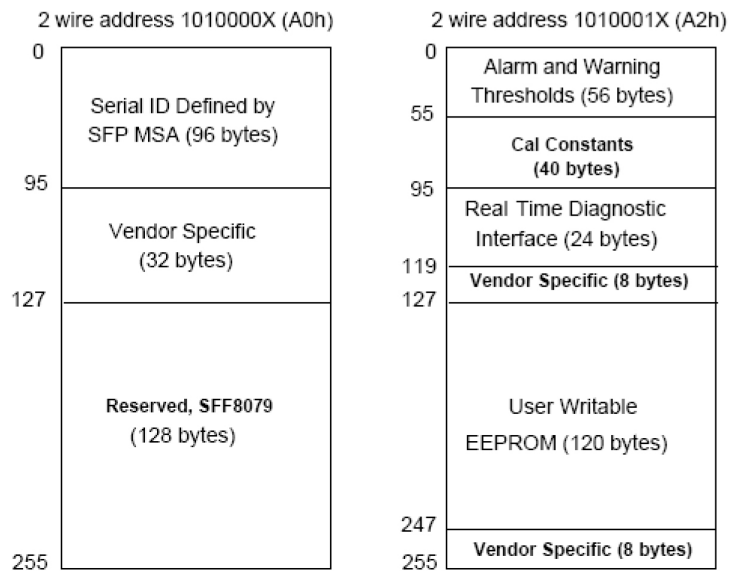

About AddOn Networks

In 1999, AddOn Networks entered the market with a single product. Our founders fulfilled a severe shortage for compatible, cost-effective optical transceivers that compete at the same performance levels as leading OEM manufacturers. Adhering to the idea of redefining service and product quality not previously had in the fiber optic networking industry, AddOn invested resources in solution design, production, fulfillment, and global support.

Combining one of the most extensive and stringent testing processes in the industry, an exceptional free tech support center, and a consistent roll-out of innovative technologies, AddOn has continually set industry standards of quality and reliability throughout its history.

Reliability is the cornerstone of any optical fiber network and is engrained in AddOn's DNA. It has played a key role in nurturing the long-term relationships developed over the years with customers. AddOn remains committed to exceeding industry standards with certifications from ranging from NEBS Level 3 to ISO 9001:2005 with every new development while maintaining the signature reliability of its products.



U.S. Headquarters

Email: sales@addonnetworks.com

Telephone: +1 877.292.1701

Fax: 949.266.9273

Europe Headquarters

Email: salesupportemea@addonnetworks.com

Telephone: +44 1285 842070