

ClearOne®

CONVERGE® PRO 880 | 880T | 880TA | 840T | 8i | TH20 | VH20 |
CONVERGE® SR 1212 | SR 1212TA |
Professional Conferencing Systems
Beamforming Microphone Array, CONVERGE USB,
CONNECT™ CobraNet® and CONNECT Dante™ Network Bridges

INSTALLATION & OPERATION MANUAL



TECHNICAL SUPPORT

Telephone	1.800.283.5936
Fax	1.801.977.0087
Email	tech.support@clearone.com
Web	www.clearone.com

CONVERGE PRO 880/880T/880TA/840T/8i/TH20/VH20, CONVERGE SR 1212/SR 1212TA Beamforming Microphone Array CONNECT CobraNet/Dante Network Bridge CONVERGE USB Network Peripheral INSTALLATION & OPERATION MANUAL

CLEARONE PART NO. 800-151-880 (REVISION 4.6) April 2016

© 2016 ClearOne Inc. - All rights reserved. Information in this document is subject to change without notice. Other product names may be registered trademarks of their respective owners who do not necessarily endorse ClearOne or ClearOne's products in the United States and/or other countries.

Adobe® Flash® Copyright and Trademark Notice

Adobe® Flash® Player. Copyright © 1996 – 2015 Adobe Systems Incorporated. All Rights Reserved. Adobe and Flash are either trademarks or registered trademarks in the United States and/or other countries.

TABLE OF CONTENTS

CHAPTER 1: INTRODUCTION	1
CONVERGE Pro Product Family Overview	1
Important Safety Information	5
CONVERGE Pro Product Descriptions	6
Customer Service and Support	18
Warranty Information	18
Operating Requirements	19
System Requirements	19
Unpacking	20
Controls and Connections	32
CHAPTER 2: EXPANSION BUS & LCD PROGRAMMING	44
Expansion Bus	44
Device ID's	45
LCD Programming Overview	47
LCD Channels Menu	50
LCD Settings Menu	51
LCD Macros Menu	53
LCD Preset Menu	54
CHAPTER 3: CONVERGE CONSOLE PROGRAMMING	55
Installing CONVERGE Console	55
CONVERGE Console Overview	58
Site File Overview	63
Connect to a Site	66
Site Properties	67
Unit Properties	72
CONVERGE Pro VH20 Unit Properties	77
Beamforming Microphone Array Unit Properties	81
CONNECT CobraNet Unit Properties	83
CONNECT Dante Unit Properties	84
Configuration Mode Overview	85
Site Tab	86
Unit Tab	86
Channel Tab Overview	102
AEC (Acoustic Echo Cancellation)	107
NC (Noise Cancellation)	110
Filters	112
AGC/ALC (Automatic Gain Control/Automatic Level Control) Tab	117
Mic Gating	119
Mic Input Settings	123
Digital Microphone Processing	129
Line Input Settings	131
Telco/VoIP Rx Settings	136
Output Settings	146
Telco/VoIP Tx Settings	150
Processing Settings	157
Fader Settings	165

TABLE OF CONTENTS (continued)

Matrix Tab	170
AEC Reference/PA Adapt Reference Tab	174
Macro Tab	177
Gating Tab	181
Control Tab	184
String Tab	187
Event Scheduler Tab	189
Database Tab	191
Optimizing Gain Structure	196
Drag and Drop Configuration	199
Preset Mode	205
File Menu Overview	212
Print Reports	214
View Menu Overview	215
Add Menu	217
Connect Menu Overview	220
Modes Menu Overview	221
Services Menu Overview	222
Dialer	223
Phonebook	225
Label Editor	227
Device Log	228
Event Log	231
Web Builder	233
Firmware Loader	238
Debug Console	242
Execute Presets	248
APPENDIX A: APPLICATION PROGRAMMER'S INTERFACE	250
Type and Device IDs	250
Conventions	250
Command Form Description	250
Groups and Channels	251
Meter Type Definitions Table	252
Serial Commands	260
Serial Command Support Table	327
All Models: RS-232 Port	334
Connecting with Telnet	334
All Models: RS-232 Port	334
APPENDIX B: DEFAULT PINOUTS	335
Control/Status Ports	335
All Models: RS-232 Port	342
APPENDIX C: FIRMWARE LOADING PROCEDURE	343

TABLE OF CONTENTS (continued)

APPENDIX D: SPECIFICATIONS	345
Converge Pro 880	345
Converge Pro 880T	347
Converge Pro 880TA	349
Converge Pro 840T	351
Converge Pro 8i	353
CONVERGE PRO 8i (continued)	354
Converge Pro TH20	355
Converge Pro VH20	356
Converge SR 1212	357
Converge SR 1212A	359
Beamforming Microphone Array	360
CONNECT CobraNet/Dante Network Bridges	361
CONVERGE USB Interface	361
APPENDIX E: COMPLIANCE	362
FCC Part 15/ICES-003 Compliance	362
FCC Part 68 Compliance	362
Electrical Safety Advisory	363
IC COMPLIANCE	363
EUROPEAN COMPLIANCE	363
NEW ZEALAND COMPLIANCE	364
JAPANESE COMPLIANCE	364
APPENDIX F: PROVISIONING THE CONVERGE VH20	365
Provisioning The Converge VH20	365
GLOSSARY	370

CHAPTER 1: INTRODUCTION

CONVERGE PRO PRODUCT FAMILY OVERVIEW

Congratulations! You have purchased a ClearOne® CONVERGE® Pro audio conferencing solution. The CONVERGE Pro product family represents a revolutionary advance in state-of-the-art audio technology for large-scale conferencing applications.

ClearOne introduced its first audio conferencing products to the market in 1990 under the brand name Gentner®. Today, ClearOne has over 80,000 installations worldwide in organizations ranging from the Fortune 1,000 to the federal government. ClearOne products are used in the most demanding conferencing applications, where they consistently deliver industry-leading audio quality and unsurpassed reliability.

ClearOne's proprietary Distributed Echo Cancellation® (DEC) technology forms the foundation of the CONVERGE Pro product family, and provides optimal audio quality for today's distributed conferencing environments. In addition to DEC, other ClearOne innovations – including noise cancellation, automatic gain and level control, advanced microphone gating, adaptive ambient, and ClearEffect™ wideband audio emulation – produce crystal-clear audio that is equivalent to conference participants being in the same room.



Applications

The CONVERGE Pro product family provides scalable conferencing solutions for any size venue. Some common applications include:

- Boardrooms
- Training rooms
- Courtrooms
- Multimedia rooms
- Distance learning
- Auditoriums
- Houses of worship
- Sound reinforcement
- Large meeting venues

Models

The CONVERGE Pro product family and associated products includes the following:

- CONVERGE Pro 880
- CONVERGE Pro 880T
- CONVERGE Pro 880TA
- CONVERGE Pro 840T
- CONVERGE Pro TH20
- CONVERGE Pro VH20
- CONVERGE Pro 8i
- CONVERGE Pro SR1212
- CONVERGE Pro SR1212A
- Beamforming Microphone Array
- CONNECT CobraNet and CONNECT Dante Network Bridges
- CONVERGE USB Interface

Common Benefits

Each product in the CONVERGE Pro product family offers the following benefits:

- Superior audio quality
- ClearOne's next generation signal processing algorithms
- Field-proven conferencing technology
- Flexible configuration and expandability
- Improved configuration and management software
- Simplified programming
- Reduced installation times
- Best-in-class processing speed
- ClearOne's world-class customer service, technical support, and field engineering services

Common Features

The leading-edge features common to all products in the CONVERGE Pro family include:

- USB connector on front panel for easy connectivity with a laptop or PC
- Dual RJ-45 Ethernet ports
- Dual RJ-45 expansion bus ports
- TDM (Time Division Multiplexed) mix/minus audio and control buses
- RS-232 serial port (up to 115,200 bps)
- Dual DB-25 control/status GPIO (General Purpose Input/Output) Ports
- Mini-phoenix audio input/output connectors (color-coded by channel type)
- Differential inputs and outputs

Feature Enhancements

CONVERGE Pro feature enhancements include:

- ClearOne's next-generation Distributed Echo Cancellation—up to eight discrete digital signal processors (DSPs) improve full-duplex performance and remove echo in the most difficult acoustic environments.
- New PTT (Push-to-Talk) microphone compatibility provides greater design and configuration flexibility.
- Advanced noise cancellation reduces background noise caused by fans, HVAC systems, and other relatively constant background noise sources.

- Up to eight independent signal processing blocks, each with 15 user-configurable filters (including all-pass, low-pass, high-pass, low-shelving, high-shelving, and parametric), delay, and compression. ClearOne's unparalleled processing power enables you to use all of these features simultaneously in any combination, allowing you to create optimized audio configurations for every environment and application.
- Enhanced expansion bus (E-bus) capabilities—connect up to 34 CONVERGE Pro units together and use up to 96 microphones and 16 telephone lines in a single CONVERGE Pro installation.
- Increased distance between units—up to 200 feet/60.96 meters.
- Graphical, user-configurable routing matrix allows you to route any input channel to any output, processing, or fader channel (or combination thereof) on any CONVERGE Pro unit, or across the expansion bus.
- Front panel control of mute and gain for all input and output channels.
- Safety mute button on the Console™ software button bar instantly mutes all outputs.
- ClearOne's DSP (Digital Signal Processing) technology ensures crystal-clear audio between conferencing sites.

AEC (Acoustical Echo Cancellation) Enhancements

- Smoothing filters to reduce artifacts
- Pre-AEC bypass channels
- Improved AEC adaption and noise suppression algorithms
- Automated Push-to-Talk microphone mode with AEC freezing
- Gain and gating control tracking
- Cross point gain adjustments
- Four fader channels
- Microphone preamp gain control
- 7 dB coarse gain and .5 dB fine gain increments for improved microphone gain matching
- AGC (Automatic Gain Control) algorithm
- ALC (Automatic Level Control) algorithm

Telephone Hybrid Enhancements (880T, 880TA, 840T, TH20)

- Custom telephone line settings for international teleconferencing and in-country localization
- Type I & Type II auto-sensing telephone interface (U.S. and E.U.)
- International impedance matching
- Improved TEC (Telco Echo Cancellation) with 31 millisecond tail time
- Continual TEC adaptation to telephone line conditions
- ClearEffect™ wideband audio emulation algorithm
- Digital anti-alias filter minimizes CO switching noise and hum
- ALC (Automatic Level Control) on telco receive channel
- Improved call management and processing
- Adjustable dial tone, DTMF attenuation
- Off-hook DTMF generation
- Robust dial tone detection
- Caller ID & selectable ringers
- Touch-tone dialing capability (44 character dial string)
- Analog telephone line compatibility
- 10 W speaker amplifier (880T, 880TA, 840T)
- Custom ring cadence detect

VoIP and SIP Functionality (VH20)

- Voice over Internet Protocol functionality - Providing telephone functionality over an Internet connection
- SIP - Session Initiation Protocol used to establish, modify and terminate VoIP calls
- Support for wideband Audio – G.722
- ClearEffect™ wideband audio emulation algorithm
- ALC (Automatic Level Control) on telco receive channel
- Caller ID & selectable ringers

Beamforming Microphone Array Enhancements

- Beamforming & adaptive steering technology
- Next-generation Acoustic Echo Cancellation
- 24 microphone elements
- Mono and stereo modes for diverse applications
- Flexible mounting for ceiling
- Works with CONVERGE Pro products: 880, 840T, 880T, 880TA
- Expandable for larger room applications by daisy-chaining up to three arrays per CONVERGE Pro unit
- Adaptive acoustic processing automatically adjusts to room configuration for best possible audio pickup
- Replaces up to 10 traditional microphones, with twice the pick-up range

CONNECT CobraNet/Dante Enhancements

- 8 x 8 I/O audio extends system boundaries, transmitting audio channels through network
- Works with all CONVERGE Pro and CONVERGE SR products
- Acts as an end-point device for the network, with up to 8 units on each E-bus
- Configuration through familiar CONVERGE Console software
- Firmware upgradable through CONVERGE Pro E-bus
- Modular approach to projects, with the ability to add and change CONNECT bridges as needed
- Installers can provide a solution based on network infrastructure, choosing CobraNet or Dante bridges
- Using the latest firmware and software, the CONNECT bridges keep the network updated without any changes in main mixer hardware
- Configuration done through CONVERGE Pro unit with familiar and easy-to-use CONVERGE Console software
- CONNECT Dante units supports 8x8 Dante Audio Channels

CONVERGE USB Enhancements

- Provides USB audio In/Out between desktops/laptops and CONVERGE units
- Plug-and-play peripheral connects desktops/laptops with professional audio for ClearOne COLLABORATE Desktop and other popular Unified Communications applications such as Skype™, Microsoft® Lync, and Google Talk™
- Easily connects with ClearOne COLLABORATE Room video conferencing system for best-in-class audio
- Used as an Expansion bus extender by extending the distance to another 200 feet per unit using E-bus In & Out ports
- Connects to CONVERGE units through E-bus
- Works with all existing CONVERGE Pro and SR products
- Powered through external power supply
- Terminal block jumpers control the E-bus channel selection
- Volume controlled through desktop/laptop

IMPORTANT SAFETY INFORMATION



Read all safety information before using this product.

1. Read these instructions.
2. Keep these instructions.
3. Heed all warnings.
4. Follow all instructions.
5. Do not use this apparatus near water.
6. Clean only with dry cloth.
7. Do not block any ventilation openings. Install in accordance with the manufacturer's instructions.
8. Do not install near any heat sources such as radiators, heat registers, stoves, or other apparatus (including amplifiers) that produce heat.
9. Do not defeat the safety purpose of the polarized or grounding-type plug. A polarized plug has two blades with one wider than the other. A grounding type plug has two blades and a third grounding prong. The wide blade or the third prong are provided for your safety. If the provided plug does not fit into your outlet, consult an electrician for replacement of the obsolete outlet. The device must be connected to a earth grounded socket. For Norway: Apparatet må tilkoples jordet stikkontakt. For Sweden: Apparaten skall anslutas till jordat uttag. For Finland: Laitte on liitettävä suojakoskettimilla varustettuun pistorasiaan.
10. Protect the power cord from being walked on or pinched particularly at plugs, convenience receptacles, and the point where they exit from the apparatus.
11. Only use attachments/accessories specified by the manufacturer.
12. Use only with the cart, stand, tripod, bracket, or table specified by the manufacturer, or sold with the apparatus. When a cart is used, use caution when moving the cart/apparatus combination to avoid injury from tip-over.
13. Unplug this apparatus during lightning storms or when unused for long periods of time.
14. Refer all servicing to qualified service personnel. Servicing is required when the apparatus has been damaged in any way, such as power-supply cord or plug is damaged, liquid has been spilled or objects have fallen into the apparatus, the apparatus has been exposed to rain or moisture, does not operate normally, or has been dropped.
15. Use the mains plug to disconnect the apparatus from the AC mains. The mains plug shall remain readily operable. For France: Utilisez la prise secteur pour débrancher l'appareil à partir du secteur. La prise secteur doit rester facilement accessible.
16. On/Off switch located on the front panel of the CONVERGE Pro 880TA and SR 1212A does NOT disconnect power from the AC mains.
17. To completely disconnect unit power from the AC mains, disconnect the unit's power cord from the mains socket. To reconnect power, plug the unit's power cord into the mains socket following all safety instructions and guidelines. For France: Pour alimentation de l'unité de couper entièrement l'alimentation secteur, débranchez le cordon d'alimentation de l'appareil de la prise de courant. Pour rétablir le courant, branchez le cordon d'alimentation de l'appareil dans la prise de courant en suivant toutes les instructions et les directives de sécurité.
18. Caution: Danger of explosion if lithium battery is incorrectly replaced. Replace only with the same or equivalent type. Battery should only be replaced by qualified personnel and is not intended as a user serviceable part. Do not expose batteries or battery pack to excessive heat such as prolonged sunlight, fire or other heat sources. For France: Attention: Danger d'explosion si la pile au lithium est remplacée de façon incorrecte. Remplacez uniquement avec le même type ou équivalent. Batterie ne doit être remplacé par du personnel qualifié et ne vise pas comme une partie réparable par l'utilisateur. Ne pas exposer les piles ou batterie à une chaleur excessive comme la lumière du soleil prolongée, le feu ou d'autres sources de chaleur.
19. Never push objects of any kind into this product through cabinet slots as they may touch dangerous voltage points or short out parts that could result in fire or electric shock.
20. This product can interfere with electrical equipment such as tape recorders, TV sets, radios, computers and microwave ovens if placed in close proximity.
21. Class 2 Wiring IS REQUIRED for these devices. Wiring and install should only be performed by qualified personnel.
22. For CONVERGE Pro products that include a telephone circuit, Underwriters Laboratories (UL) requires these safety notifications:

Caution: To reduce the risk of fire, use only No. 26 AWG or larger UL Listed or CSA Certified Telecommunication Line Cord.

- When using your telephone equipment, basic safety precautions should always be followed to reduce the risk of fire, electric shock and injury to persons, including the following:
- Do not use this product near water for example, near a bathtub, washbowl, kitchen sink or laundry tub, in a wet basement or near a swimming pool.
- Avoid using a telephone (other than a cordless type) during an electrical storm. There may be a remote risk of electric shock from lightning.
- Do not use the telephone to report a gas leak in the vicinity of the leak.
- Use only the power cord and batteries indicated in this manual. Do not dispose of batteries in a fire. They may explode. Check with local codes for possible special disposal instructions.

WARNING: TO PREVENT FIRE OR ELECTRICAL SHOCK HAZARD, DO NOT EXPOSE THIS PRODUCT TO RAIN OR MOISTURE.

 <p>THE LIGHTNING FLASH AND ARROW HEAD WITHIN THE TRIANGLE IS A WARNING SIGN ALERTING YOU OF DANGEROUS VOLTAGE INSIDE THE PRODUCT</p>	<p>CAUTION</p> <p>RISK OF ELECTRIC SHOCK DO NOT OPEN</p> <p>AVIS: RISQUE DE CHOC ELECTRIQUE - NE PAS OUVRIIR</p> <p>CAUTION: TO REDUCE THE RISK OF ELECTRIC SHOCK, DO NOT REMOVE COVER (OR BACK) NO USER SERVICEABLE PARTS INSIDE. REFER SERVICING TO QUALIFIED SERVICE PERSONNEL.</p>	 <p>THE EXCLAMATION POINT WITHIN THE TRIANGLE IS A WARNING SIGN ALERTING YOU OF IMPORTANT INSTRUCTIONS ACCOMPANYING THE PRODUCT.</p>
SEE MARKING ON BOTTOM / BACK OF PRODUCT		



Use only in non-tropical locations.
(Except 880TA and SR1212A)



Use only at altitudes of 2000 meters or less.

Save These Instructions

CONVERGE PRO PRODUCT DESCRIPTIONS

CONVERGE Pro 880TA



The 880TA stands as the new flagship of the CONVERGE Pro line. Re-designed, re-tooled with added power and functionality, the 880TA also provides industry-leading expansion capabilities.

Advanced Telephone Conferencing Feature Set

- Signal Processing Improvements
 - » Telephone noise cancellation (receive channel)
 - » ClearEffect™ wide-band emulation for speech enhancement
 - » Automatic level control (receive channel)
 - » Caller ID & selectable ringers
 - » Custom ring cadence detect

Advanced Conferencing Feature Set

- Enhanced Feedback Canceller
- Multichannel Control on each amplifier
- Next-generation Acoustic Echo Cancellation
 - » Improved duplex performance
 - » Push-to-talk microphone compatibility
- Next-generation Noise Cancellation
 - » Adaptive modeling to room ambient noise conditions
- Pre-AEC routing for sound reinforcement applications
 - » A maximum processing delay of four (4) milliseconds
- Management Improvements
 - » Integrated Ethernet and USB connections
 - » SNMP and HTML remote management agents with SMTP email alerts
 - » Web-based user and management control consoles
 - » Event scheduler
 - » Diagnostic console
- Simplified Configuration Software
 - » Drag & drop A/V and channel objects
 - » Selectable Console views—Unit, Matrix, and Channel

Superior Audio Performance

- Next-generation Distributed Echo Cancellation on every microphone input
- First-microphone priority delivers clear audio to the far end
- 20Hz – 22kHz bandwidth for full-range audio response
- AGC & ALC to keep all participants' audio levels balanced and consistent

Configuration Flexibility

- Scalable—link up to 34 CONVERGE Pro units together for up to 96 microphones and 16 telephone lines
 - » 18 expansion busses
- Enhanced expansion bus, featuring 18 mix-minus audio buses for routing between units
- Ten microphone gating groups (four internal & six global) allow separation of microphones into individual mixer gating groups for greater configuration flexibility
- 32 user-programmable presets can each be executed without disturbing other ongoing preset operations
- 255 Macros for customized audio control and configuration using a single command

CONVERGE Pro 880



The successor to the industry-leading XAP® 800. The 880 delivers rich functionality with improved audio performance, enhanced management, and simplified configuration for audio conferencing and sound reinforcement applications.

Advanced Conferencing Feature Set

- Next-generation Acoustic Echo Cancellation
 - » Improved duplex performance
 - » Push-to-talk microphone compatibility
- Next-generation Noise Cancellation
 - » Adaptive modeling to room ambient noise conditions
- Increased resolution on Microphone Preamp stage
 - » 0 – 56dB in 7dB increments
- Pre-AEC routing for sound reinforcement applications
 - » A maximum processing delay of four (4) milliseconds
- Management Improvements
 - » Integrated Ethernet and USB connections
 - » SNMP and HTML remote management agents with SMTP email alerts
 - » Web-based user and management control consoles
 - » Event scheduler
 - » Diagnostic console
- Simplified Configuration Software
 - » Drag & drop A/V and channel objects
 - » Selectable Console views—Unit, Matrix, and Channel
- Expanded serial command set

Superior Audio Performance

- Next-generation Distributed Echo Cancellation on every microphone input
- First-microphone priority delivers clear audio to the far end
- 20Hz – 22kHz bandwidth for full-range audio response
- AGC & ALC to keep all participants' audio levels balanced and consistent

Configuration Flexibility

- Scalable—link up to 34 CONVERGE Pro units together for up to 96 microphones and 16 telephone lines
- Enhanced expansion bus, featuring 18 mix/minus audio buses for routing between units
- Ten microphone gating groups (four internal & six global) allow separation of microphones into individual mixer gating groups for greater configuration flexibility
- 32 user-programmable presets can each be executed without disturbing other ongoing preset operations
- 255 Macros for customized audio control and configuration using a single command

CONVERGE Pro 880T



The 880T leverages the rich functionality of the CONVERGE Pro 880, and adds a built-in telephone interface and power amplifier for standalone conferencing applications. The 880T also provides industry-leading expansion capabilities, allowing you to connect it with other CONVERGE Pro units for complex installations.

Advanced Telephone Conferencing Feature Set

- Signal Processing Improvements
 - » Telephone noise cancellation (receive channel)
 - » ClearEffect™ wideband emulation for speech enhancement
 - » Automatic level control (receive channel)
 - » Caller ID & selectable ringers

Advanced Conferencing Feature Set

- Next-generation Acoustic Echo Cancellation
 - » Improved duplex performance
 - » Push-to-talk microphone compatibility
- Next-generation Noise Cancellation
 - » Adaptive modeling to room ambient noise conditions
- Increased resolution on Microphone Preamp stage
 - » 0 – 56dB in 7dB increments
- Pre-AEC routing for sound reinforcement applications
 - » A maximum processing delay of four (4) milliseconds
- Management Improvements
 - » Integrated Ethernet and USB connections
 - » SNMP and HTML remote management agents with SMTP email alerts
 - » Web-based user and management control consoles
 - » Event scheduler
 - » Diagnostic console
- Simplified Configuration Software
 - » Drag & drop A/V and channel objects
 - » Selectable Console views—Unit, Matrix, and Channel
- Expanded serial command set

Superior Audio Performance

- Next-generation Distributed Echo Cancellation on every microphone input
- First-microphone priority delivers clear audio to the far end
- 20Hz – 22kHz bandwidth for full-range audio response
- AGC & ALC to keep all participants' audio levels balanced and consistent

Configuration Flexibility

- Scalable—link up to 34 CONVERGE Pro units together for up to 96 microphones and 16 telephone lines
- Enhanced expansion bus, featuring 18 mix-minus audio buses for routing between units
- Ten microphone gating groups (four internal & six global) allow separation of microphones into individual mixer gating groups for greater configuration flexibility
- 32 user-programmable presets can each be executed without disturbing other ongoing preset operations
- 255 Macros for customized audio control and configuration using a single command

CONVERGE Pro 840T



The successor to the industry-leading XAP 400. The 840T provides the same rich feature set as the 880T, complete with a built-in telephone interface and power amplifier for standalone conferencing applications. For large venues, the 840T also provides industry-leading expansion capabilities via ClearOne's expansion bus technology.

Advanced Telephone Conferencing Feature Set

- Signal Processing Improvements
 - » Telephone noise cancellation (receive channel)
 - » ClearEffect™ wideband emulation for speech enhancement
 - » Automatic level control (receive channel)
 - » Caller ID & selectable ringers

Advanced Conferencing Feature Set

- Next-generation Acoustic Echo Cancellation
 - » Improved duplex performance
 - » Push-to-talk microphone compatibility
- Next-generation Noise Cancellation
 - » Adaptive modeling to room ambient noise conditions
- Increased resolution on Microphone Preamp stage
 - » 0 – 56dB in 7dB increments
- Pre-AEC routing for sound reinforcement applications
 - » A maximum processing delay of four (4) milliseconds
- Management Improvements
 - » Integrated Ethernet and USB connections
 - » SNMP and HTML remote management agents with SMTP email alerts
 - » Web-based user and management control consoles
 - » Event scheduler
 - » Diagnostic console
- Simplified Configuration Software
 - » Drag & drop A/V and channel objects
 - » Selectable Console views—Unit, Matrix, and Channel
- Expanded serial command set

Superior Audio Performance

- Next-generation Distributed Echo Cancellation on every microphone input
- First-microphone priority delivers clear audio to the far end
- 20Hz – 22kHz bandwidth for full-range audio response
- AGC & ALC to keep all participants' audio levels balanced and consistent

Configuration Flexibility

- Scalable—link up to 34 CONVERGE Pro units together for up to 96 microphones and 16 telephone lines
- Enhanced expansion bus, featuring 18 mix-minus audio buses for routing between units
- Eight microphone gating groups (four internal & four global) allow separation of microphones into individual mixer gating groups for greater configuration flexibility
- 32 user-programmable presets can each be executed without disturbing other ongoing preset operations
- 255 Macros for customized audio control and configuration using a single command

CONVERGE Pro 8i



An input-only expansion box for the CONVERGE Pro platform. The 8i delivers new economical configuration flexibility. It can be added to 880, 840T, and TH20 systems for additional microphone and line inputs, allowing customers to match the number of inputs and outputs required for specific conferencing and sound reinforcement installations.

Advanced Conferencing Feature Set

- Economical Mic/Line only mixer for large configurations where additional output channels are not required
- Next-generation Acoustic Echo Cancellation
 - » Improved duplex performance
 - » Push-to-talk microphone compatibility
- Next-generation Noise Cancellation
 - » Adaptive modeling to room ambient noise conditions
- Increased resolution on Microphone Preamp stage
 - » 0 – 56dB in 7dB increments
- Pre-AEC routing for sound reinforcement applications
 - » A maximum processing delay of four (4) milliseconds
- Management Improvements
 - » Integrated Ethernet and USB connections
 - » SNMP and HTML remote management agents with SMTP email alerts
 - » Web-based user and management control consoles
 - » Event scheduler
 - » Diagnostic console
- Simplified Configuration Software
 - » Drag & drop A/V and channel objects
 - » Selectable Console views—Unit, Matrix, and Channel
- Expanded serial command set

Superior Audio Performance

- Next-generation Distributed Echo Cancellation on every microphone input
- First-microphone priority delivers clear audio to the far end
- 20Hz – 22kHz bandwidth for full-range audio response
- AGC & ALC to keep all participants' audio levels balanced and consistent

Configuration Flexibility

- Scalable—link up to 34 CONVERGE Pro units together for up to 96 microphones and 16 telephone lines
- Enhanced expansion bus, featuring 18 mix-minus audio buses for routing between units
- Ten microphone gating groups (four internal & six global) allow separation of microphones into individual mixer gating groups for greater configuration flexibility
- 32 user-programmable presets can each be executed without disturbing other ongoing preset operations
- 255 Macros for customized audio control and configuration using a single command

CONVERGE Pro TH20



The successor to the industry-leading XAP TH2, the TH20 enables conference call functionality for CONVERGE Pro installations through the addition of a telephone interface. The TH20 expansion bus allows you to link up to 16 TH20 units together for industry-leading conferencing capability. It also adds two line-level inputs and outputs for increased system capacity.

Advanced Telephone Conferencing Feature Set

- Signal Processing Improvements
 - » Telephone noise cancellation (receive channel)
 - » ClearEffect™ wideband emulation for speech enhancement
 - » Automatic level control (receive channel)
 - » Caller ID
 - » Selectable ringers
- Increased I/O capabilities
 - » Two line-level inputs and two line-level outputs
 - » Audio Expansion bus (E-bus)
- Management Improvements
 - » Integrated Ethernet and USB connections
 - » SNMP and HTML remote management agents with SMTP email alerts
 - » Web-based user and management control consoles
 - » Event scheduler
 - » Diagnostic console
- Simplified Configuration Software
 - » Drag & drop A/V and channel objects
 - » Selectable Console views—Unit, Matrix, and Channel
- Expanded serial command set

Superior Audio Performance

- Next-generation Distributed Echo Cancellation on every microphone input
- 20Hz – 22kHz bandwidth for full-range audio response
- AGC on line inputs to keep gain levels balanced and consistent

Configuration Flexibility

- Scalable—link up to 34 CONVERGE Pro units together for up to 96 microphones and 16 telephone lines
- Enhanced expansion bus, featuring 18 mix-minus audio buses for routing between units
- Eight microphone gating groups (four internal & four global) allow separation of microphones into individual mixer gating groups for greater configuration flexibility
- 32 user-programmable presets can each be executed without disturbing other ongoing preset operations
- 255 Macros for customized audio control/configuration with single command execution

CONVERGE Pro VH20



The VH20 enables VoIP call functionality for CONVERGE Pro installations through the addition of a SIP interface. The VH20 expansion bus allows you to link to other CONVERGE Pro units and up to 16 VH20 units together for industry-leading conferencing capability. It also adds two line-level audio inputs and outputs for increased system capacity.

Advanced Feature Set

- SIP Features
 - » Dual Proxy Registration
- Call Features
 - » Speedial/Redial
- Network Features
 - » DNS
 - » VLAN Tagging
 - » TLS Encryption for added security
- Management Features
 - » HTTP Server
 - » XML Dial Plan
 - » SNMP Agent
 - » Sntp
 - » BootP Services

Superior Audio Performance

- G.722 Wide band audio
- AGC on line inputs to keep gain levels balanced and consistent

Configuration Flexibility

- Scalable: Link up to 34 CONVERGE Pro units together for up to 96 microphones and 16 telephone lines
- Enhanced expansion bus, featuring 18 mix-minus audio buses for routing between units
- 32 user-programmable presets can each be executed without disturbing other ongoing preset operations
- 255 Macros for customized audio control/configuration with single command execution

Compatibility/Interoperability

- Cisco
- Avaya
- Nortel
- Codian/Tandberg
- Polycom/Accord
- Radvision MCU

CONVERGE Pro SR 1212A



The SR1212A is a 12x12 digital matrix mixer that is the ideal solution for sound reinforcement and room combining applications. In addition to improved audio performance, enhanced management, and simplified configuration, the SR1212 offers industry-leading expansion capabilities to accommodate virtually any size venue.

Advanced Conferencing Feature Set

- Increased resolution on Microphone Preamp stage
 - » 0 – 56dB in 7dB increments
- Management Improvements
 - » Integrated Ethernet and USB connections
 - » SNMP and HTML remote management agents with SMTP email alerts
 - » Web-based user and management control consoles
 - » Event scheduler
 - » Diagnostic console
- Simplified Configuration Software
 - » Drag & drop A/V and channel objects
 - » Selectable Console views—Unit, Matrix, and Channel
- Expanded serial command set

Superior Audio Performance

- First-microphone priority delivers clear audio to the far end
- 20Hz – 22kHz bandwidth for full-range audio response
- AGC & ALC to keep all participants' audio levels balanced and consistent

Configuration Flexibility

- Scalable—link up to 34 CONVERGE Pro units together for up to 96 microphones and 16 telephone lines
- Enhanced expansion bus, featuring 18 mix/minus audio buses for routing between units
- Eight microphone gating groups (four internal & four global) allow separation of microphones into individual gating groups
- 32 user-programmable presets can each be executed without disturbing other ongoing preset operations
- 255 Macros for customized audio control and configuration using a single command

CONVERGE Pro SR1212



The successor to ClearOne's PSR1212, the SR1212 is a 12x12 digital matrix mixer that is the ideal solution for sound reinforcement and room combining applications. In addition to improved audio performance, enhanced management, and simplified configuration, the SR1212 offers industry-leading expansion capabilities to accommodate virtually any size venue.

Advanced Conferencing Feature Set

- Increased resolution on Microphone Preamp stage
 - » 0 – 56dB in 7dB increments
- Management Improvements
 - » Integrated Ethernet and USB connections
 - » SNMP and HTML remote management agents with SMTP email alerts
 - » Web-based user and management control consoles
 - » Event scheduler
 - » Diagnostic console
- Simplified Configuration Software
 - » Drag & drop A/V and channel objects
 - » Selectable Console views—Unit, Matrix, and Channel
- Expanded serial command set

Superior Audio Performance

- First-microphone priority delivers clear audio to the far end
- 20Hz – 22kHz bandwidth for full-range audio response
- AGC & ALC to keep all participants' audio levels balanced and consistent

Configuration Flexibility

- Scalable—link up to 34 CONVERGE Pro units together for up to 96 microphones and 16 telephone lines
- Enhanced expansion bus, featuring 18 mix/minus audio buses for routing between units
- Eight microphone gating groups (four internal & four global) allow separation of microphones into individual gating groups
- 32 user-programmable presets can each be executed without disturbing other ongoing preset operations
- 255 Macros for customized audio control and configuration using a single command

Beamforming Microphone Array

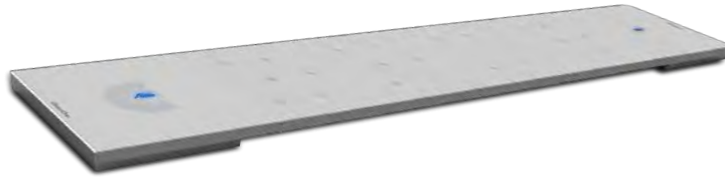

The Beamforming Microphone Array is the Pro-Audio industry's first professional-grade microphone array with beamforming and adaptive steering technology and ClearOne's next-generation Acoustic Echo Cancellation. The ultra-sleek design fits into any conferencing environment and delivers the clearest audio pickup available with adaptive acoustic processing.

Acoustic Characteristics

- 24 microphones
- Auto voice tracking
- Polar Pattern: Custom
- Frequency Response: 150Hz - 16kHz
- Signal to Noise Ratio: > 70 dB
- AEC Tail time: 128 ms
- Noise Cancellation: 6 - 15 dB adjustable

Auto Mixer Parameters

- Number of Open Microphones (NOM)
- First mic priority mode
- Last mic mode
- Maximum number of mics mode
- Ambient level
- Gate threshold adjust
- Off attenuation adjust
- Hold time
- Decay rate

Matrix Mixing Parameters

- 1 Channel In
- 18 Expansion Bus In/Out

Beamforming Microphone Array Configuration

- Echo cancellation on/off
- Noise cancellation on/off
- Filters:
 - » All Pass
 - » Low Pass
 - » High Pass
 - » Notch
 - » PEQ
- ALC on/off
- Gain adjust
- Mute on/off
- Auto gate/manual gate

CONNECT CobraNet and CONNECT Dante Network Bridges



CONNECT CobraNet/Dante bridges provide networked audio for CONVERGE Pro devices without changing main mixer hardware. A modular approach to networking allows use of CobraNet or Dante standards as needed with CONNECT network bridges.

Features

- Works with all CONVERGE Pro and CONVERGE SR products
- Future-proof; designed to work with future professional audio and emerging technology
- Modular approach allows you to build your system over time
- Acts as an end-point device for the network, with up to 8 units on each expansion bus
- Configuration through familiar CONVERGE Console software
- Firmware upgradable through CONVERGE Pro expansion bus
- Compact, 1/3 RU size
- Dante unit Supports 8x8 Dante Audio Channels
- Dante unit 8 x 8 I/O audio extends system boundaries, transmitting audio channels through network

CONVERGE USB Audio Interface



The CONVERGE USB device provides plug-and-play USB audio In/Out (transmit/receive) connectivity between popular desktop and laptop UC applications or COLLABORATE® Room Pro and CONVERGE Pro for full, rich, professional sound.

The CONVERGE USB also can serve as a E-bus extender. The CONVERGE USB can, for example, be up to 200 feet from the stack, then re-send the signal for up to another 200 feet to the next E-bus component.

Features

- Provides USB audio In/Out between desktops/laptops and CONVERGE units
- Plug-and-play peripheral connects desktops/laptops with professional audio for ClearOne COLLABORATE Desktop and other popular UC applications such as Skype™
- Easily connects with ClearOne COLLABORATE Room video conferencing system for best-in-class audio
- Used as Expansion bus extender by extending the distance to another 200 feet per unit, by using expansion bus In & Out ports
- Connects to CONVERGE units through expansion bus
- CONVERGE Pro units require version 4.0 and above firmware & software
- Works with all existing CONVERGE Pro and SR products
- Powered through external power supply
- GPIO pin controls the expansion bus selection
- Volume controlled through desktop/laptop

CUSTOMER SERVICE AND SUPPORT

ClearOne is committed to providing best-in-class customer service and support. If you need assistance installing, configuring, or operating your CONVERGE Pro system, or if you have questions about ClearOne products or services, please contact us at one of the locations listed below. ClearOne also welcomes your comments and suggestions.

ClearOne on the Web

Corporate Website: www.clearone.com
Sales Email: sales@clearone.com
Tech Support Email: tech.support@clearone.com

North America (Worldwide Headquarters)

ClearOne Communications
Edgewater Corporate Park, South Tower
5225 Wiley Post Way, Suite 500
Salt Lake City, Utah 84116 USA

Telephone: 801-975-7200
Fax: 801-303-5711
Toll-Free: 800-945-7730
Tech Support: 800-283-5936

Latin America

Telephone: 801-974-3621
Sales Email: global@clearone.com
Tech Support Email: tech.support@clearone.com

Europe and Oceania

Telephone: +44 1454 616 977
Sales Email: global@clearone.com
Tech Support Email: tech.support@clearone.com

Middle East

Telephone: 852-3590-4526
Sales Email: global@clearone.com
Tech Support Email: tech.support@clearone.com

Asia-Pacific/Japan/Oceania

Telephone: +852-3590-4526
Sales Email: global@clearone.com
Tech Support Email: tech.support@clearone.com

WARRANTY INFORMATION

ClearOne, Inc. warrants that this CONVERGE Pro product is free of defects in both material and workmanship. For complete warranty information including length, coverage, and limitations, visit http://www.clearone.com/support_policies_warranty

OPERATING REQUIREMENTS

Power

CONVERGE Pro devices automatically accommodate voltages of 100–240 VAC, 50/60 Hz, 15 W.

Telephone

CONVERGE Pro devices operate on a standard analog telephone line and connect to the telephone system with a standard RJ-11 modular jack. If you do not have an RJ-11 jack where you want to install your CONVERGE Pro, call your local telephone company for installation. CONVERGE Pro 840T, 880T, 880TA and TH20 can be configured to meet compliance requirements of different countries via the Console software.



WARNING: The country code must be set correctly in Console to ensure that the unit operates properly when connected to the telco network, and that it complies with the country's telco requirements. Changing this code to a country other than the intended country of operation might cause CONVERGE Pro devices to be non-compliant.

Equipment Placement

CONVERGE Pro devices are designed for installation in a standard 19-inch equipment rack.

Environmental

CONVERGE Pro devices are designed to operate at ambient unit temperatures between 14° F (-10° C) and 122° F (50° C).

SYSTEM REQUIREMENTS

The CONVERGE Pro Console software minimum system requirements are:

Supported Operating Systems

- Windows XP (SP3)
- Windows Vista
- Windows 7
- Windows 8

Minimum System Requirements

- AMD 600 MHz class processor (1 GHz or higher recommended)
- 1GB RAM Minimum (or higher recommended)
- 300MB hard disk space minimum (Additional space is required to store the site files and other project files)
- USB or Ethernet Network Interface to connect your computer with CONVERGE Pro product

Minimum Software Requirements

- Administrator permission to install and run the software
- Java Runtime Environment version 6.0 or higher
- Microsoft Internet Explorer version 4.0 or higher
- Adobe Flash version 9.0 or higher

UNPACKING

Use the illustrations below to verify that you received all components for your CONVERGE Pro product. ClearOne is not responsible for product damage incurred during shipment. Inspect your shipment carefully for obvious signs of damage. If the shipment appears damaged, retain the original boxes and packing material for inspection by the carrier, and contact them immediately.

CONVERGE Pro 880 Package Contents

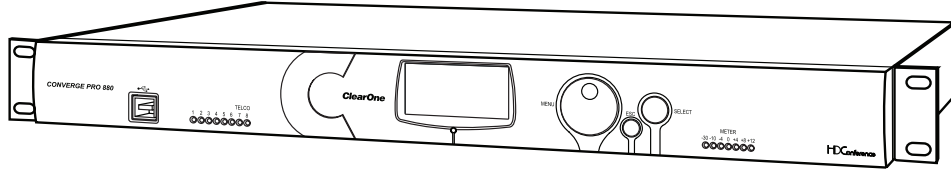

(1) Converse Pro 880
P/N: 910-151-880



(1) Terminal Block Connector, 12 Position (Green)
P/N: 673-017-212



(1) Screw/Washer Kit
P/N: 680-000-001

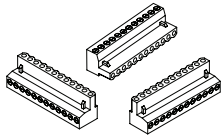

(3) Terminal Block Connector, 12 Position (Black)
P/N: 673-017-012

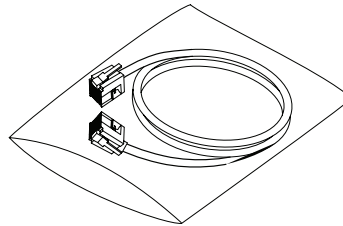

(1) RJ-45/RJ-45 Patch Cable, 18"
P/N: 830-150-004

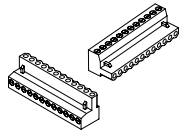

(2) Terminal Block Connector, 12 Position (Orange)
P/N: 673-017-112

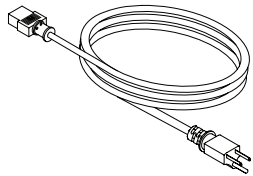

(1) Grounded Power Cord, 8'
P/N: 699-150-006

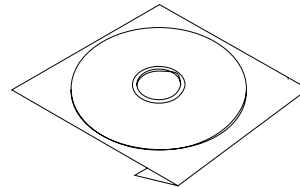

(1) Converse Pro Software & Documentation CD
P/N: 800-151-881



(1) Converse Pro Installation & Operation Manual
P/N: 800-151-880

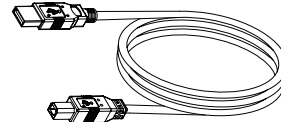

(1) USB Type A to Type B Cable, 6'
P/N: 830-153-001

CONVERGE Pro 880T Package Contents

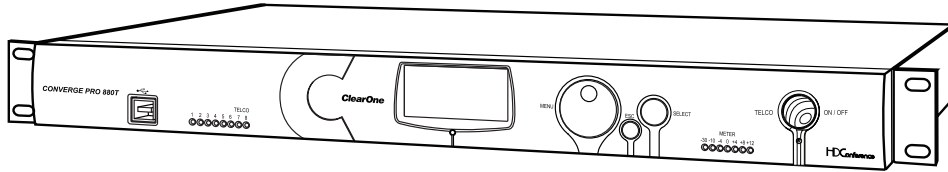

(1) Converge Pro 880T
P/N: 910-151-881



(1) Terminal Block Connector, 12 Position (Green)
P/N: 673-017-212



(1) Screw/Washer Kit
P/N: 680-000-001

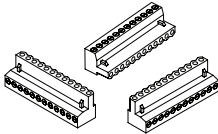

(3) Terminal Block Connector, 12 Position (Black)
P/N: 673-017-012

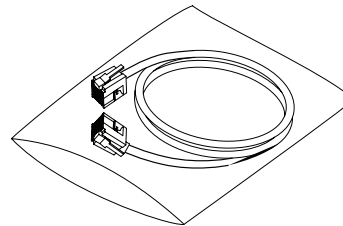

(1) RJ-45/RJ-45 Patch Cable, 18"
P/N: 830-150-004

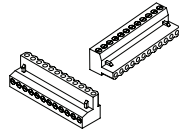

(2) Terminal Block Connector, 12 Position (Orange)
P/N: 673-017-112

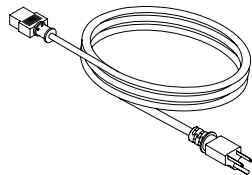

(1) Grounded Power Cord, 8'
P/N: 699-150-006

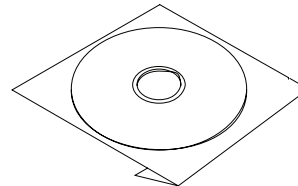

(1) Converge Pro Software & Documentation CD
P/N: 800-151-881



(1) Converge Pro Installation & Operation Manual
P/N: 800-151-880

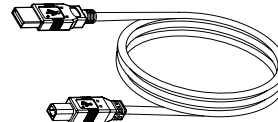

(1) USB Type A to Type B Cable, 6'
P/N: 830-153-001

CONVERGE Pro 880TA Package Contents

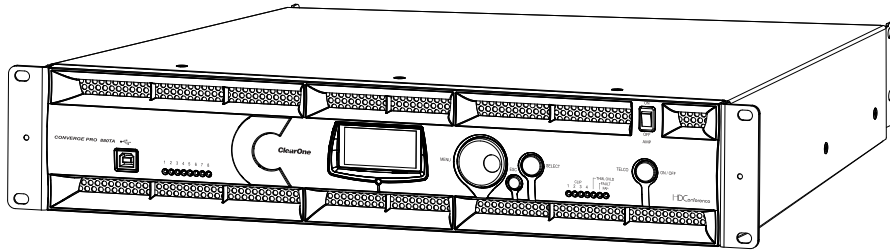

CONVERGE PRO 880TA (QTY 1)



CONN, TERM BLOCK/F 12 POS GREEN
673-017-212 (QTY 1)



SCREW/WASHER ACC KIT, RACK DECOR 4EA BLK
680-000-001 (QTY 1)

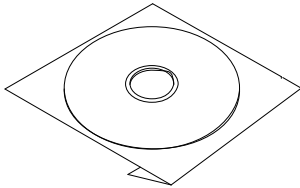

CD, CONVERGE PRO PRODUCT FAMILY
800-151-881 (QTY 1)

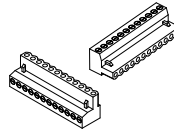

CONN, TERM BLOCK/F 12 POS BLACK
673-017-012 (QTY 2)

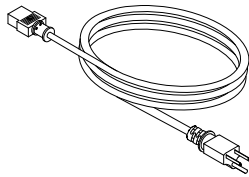

PWR CORD, MOLDED 6' BLK 3 COND
699-150-006 (QTY 1)

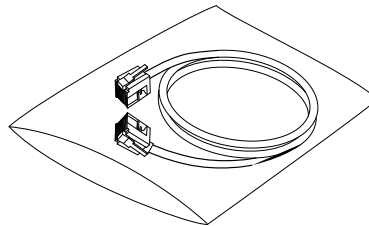

CABLE ASSEMBLY, RJ45/RJ45 18"
830-150-004 (QTY 1)

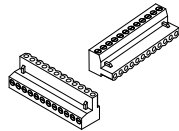

CONN, TERM BLOCK/F 12 POS ORANGE
673-017-112 (QTY 2)

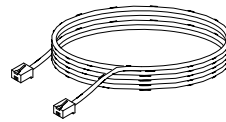

CABLE ASSY, TELEPHONE 12FT.
830-000-012 (QTY 1)

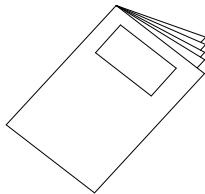

MANUAL, CONVERGE
800-151-880 (QTY 1)

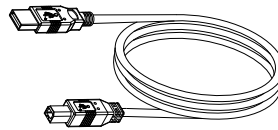

CABLE ASSY, USB A-B TYPE 6FT
830-153-001 (QTY 1)

CONVERGE Pro 840T Package Contents

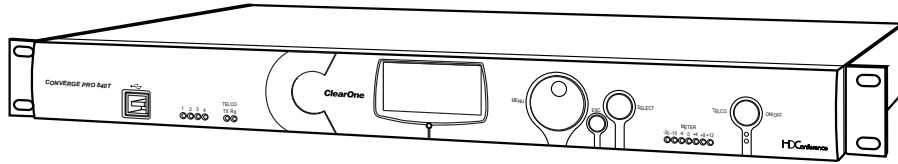

(1) Converge Pro 840T
P/N: 910-151-840



(1) Terminal Block Connector, 12 Position (Green)
P/N: 673-017-212



(1) Screw/Washer Kit
P/N: 680-000-001

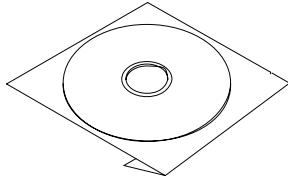

(1) Software & Documentation CD
P/N: 800-151-881

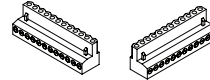

(2) Terminal Block Connector, 12 Position (Black)
P/N: 673-017-012

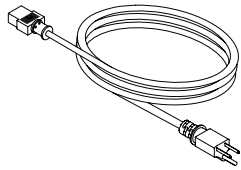

(1) Grounded Power Cord, 8'
P/N: 699-150-006

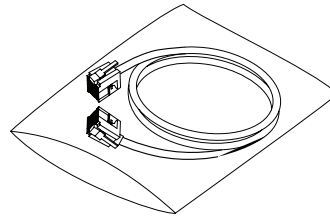

(1) RJ-45/RJ-45 Patch Cable, 18"
P/N: 830-150-004



(1) Terminal Block Connector, 12 Position (Orange)
P/N: 673-017-112

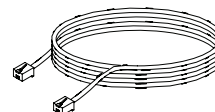

(1) Telephone Cable 12'
P/N: 830-000-012



(1) Installation & Operation Manual
P/N: 800-151-880

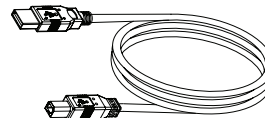

(1) USB Type A to Type B Cable, 6'
P/N: 830-153-001

CONVERGE Pro 8i Package Contents

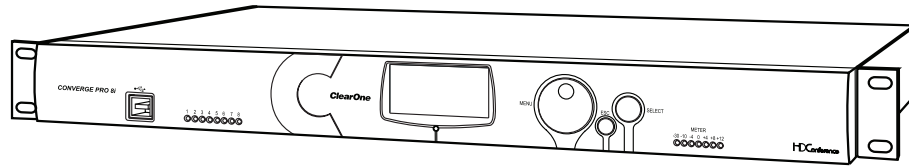

(1) Converge Pro 8i
P/N: 910-151-810



(1) Terminal Block Connector, 12 Position (Green)
P/N: 673-017-212



(1) Screw/Washer Kit
P/N: 680-000-001

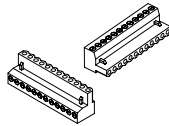

(2) Terminal Block Connector, 12 Position (Orange)
P/N: 673-017-112

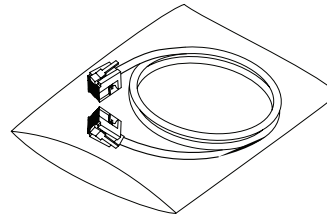

(1) RJ-45/RJ-45 Patch Cable, 18"
P/N: 830-150-004

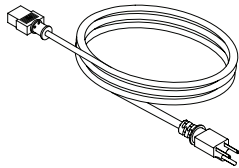

(1) Grounded Power Cord, 8'
P/N: 699-150-006

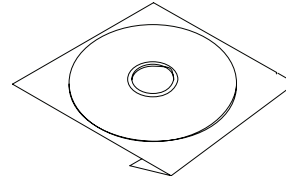

(1) Software & Documentation CD
P/N: 800-151-881



(1) Installation & Operation Manual
P/N: 800-151-880

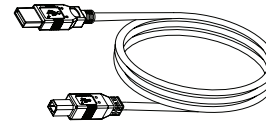

(1) USB Type A to Type B Cable, 6'
P/N: 830-153-001

CONVERGE Pro TH20 Package Contents

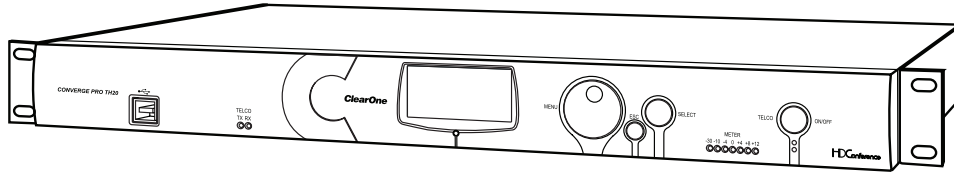

(1) Converge Pro TH20
P/N: 910-151-820

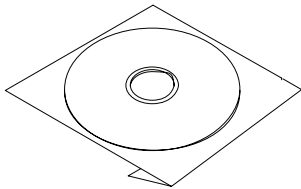

(1) Software & Documentation CD
P/N: 800-151-881



(1) Screw/Washer Kit
P/N: 680-000-001

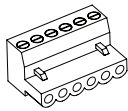

(1) Terminal Block Connector, 6 Position (Black)
P/N: 673-017-006

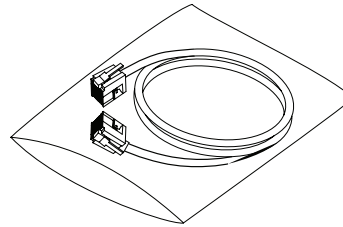

(1) RJ-45/RJ-45 Patch Cable, 18"
P/N: 830-150-004

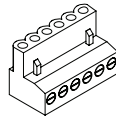

(1) Terminal Block Connector, 6 Position (Green)
P/N: 673-017-016

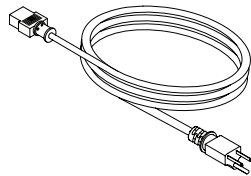

(1) Grounded Power Cord, 8'
P/N: 699-150-006

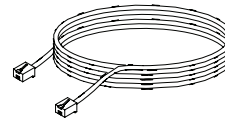

(1) Telephone Cable, 12'
P/N: 830-000-012



(1) Installation & Operation Manual
P/N: 800-151-880

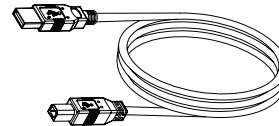

(1) USB Type A to Type B Cable, 6'
P/N: 830-153-001

CONVERGE Pro VH20 Package Contents

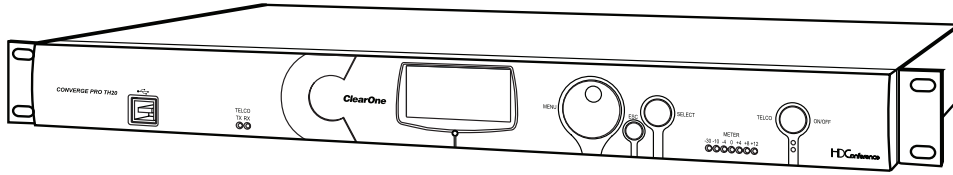

(1) Converge Pro VH20
P/N: 910-151-825

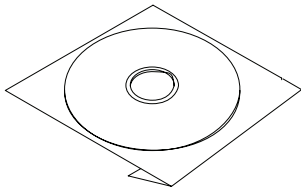

(1) Software & Documentation CD
P/N: 800-151-881

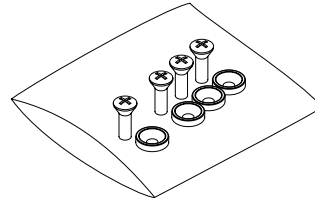

(1) Screw/Washer Kit
P/N: 680-000-001

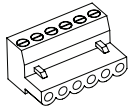

(1) Terminal Block Connector, 6 Position (Black)
P/N: 673-017-006

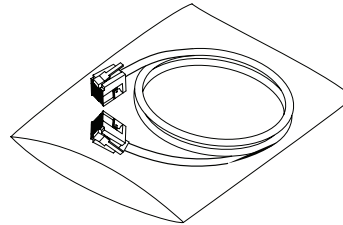

(1) RJ-45/RJ-45 Patch Cable, 18"
P/N: 830-150-004

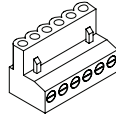

(1) Terminal Block Connector, 6 Position (Green)
P/N: 673-017-016

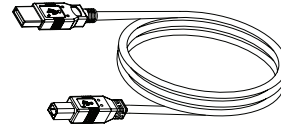

(1) USB Type A to Type B Cable, 6'
P/N: 830-153-001

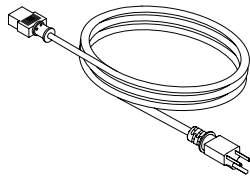

(1) Grounded Power Cord, 8'
P/N: 699-150-006

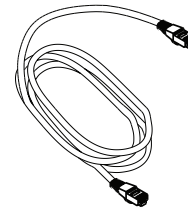

(1) RJ-45/RJ-45 Cable Assembly, 7'
P/N: 830-000-023L

CONVERGE Pro SR1212 Package Contents

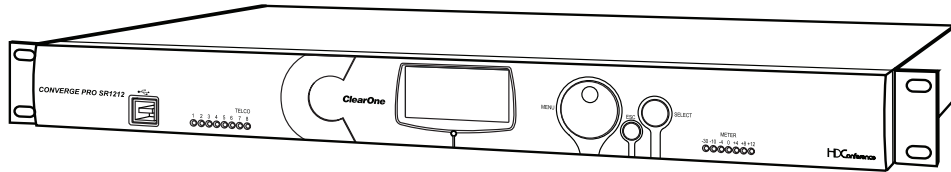

(1) Converge Pro SR1212
P/N: 910-151-900



(1) Terminal Block Connector, 12 Position (Green)
P/N: 673-017-212



(1) Screw/Washer Kit
P/N: 680-000-001

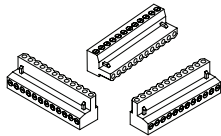

(3) Terminal Block Connector, 12 Position (Black)
P/N: 673-017-012

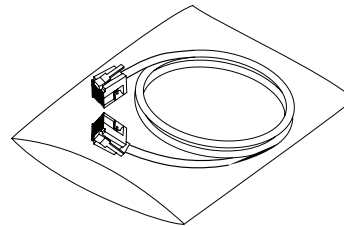

(1) RJ-45/RJ-45 Patch Cable, 18"
P/N: 830-150-004

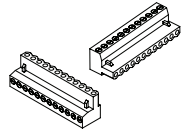

(2) Terminal Block Connector, 12 Position (Orange)
P/N: 673-017-112

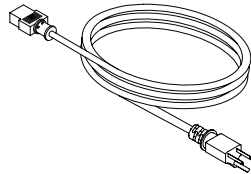

(1) Grounded Power Cord, 8'
P/N: 699-150-006

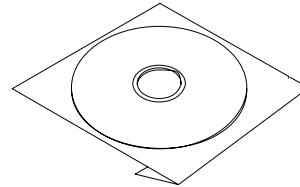

(1) Converge Pro Software & Documentation CD
P/N: 800-151-881



(1) Converge Pro Installation & Operation Manual
P/N: 800-151-880

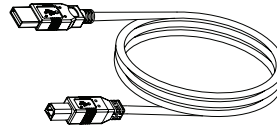

(1) USB Type A to Type B Cable, 6'
P/N: 830-153-001

CONVERGE Pro SR1212A Package Contents

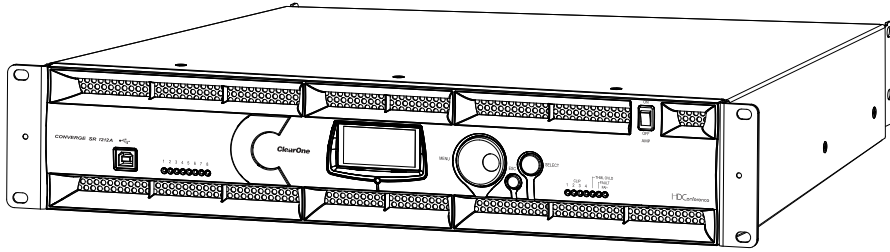

CONVERGE SR 1212A (QTY 1)

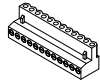

CONN, TERM BLOCK/F 12 POS GREEN
673-017-212 (QTY 1)



SCREW/WASHER ACC KIT, RACK DECOR 4EA BLK
680-000-001 (QTY 1)

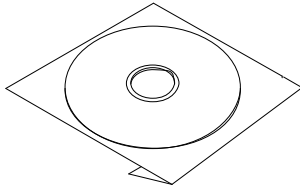

CD, CONVERGE PRO PRODUCT FAMILY
800-151-881 (QTY 1)

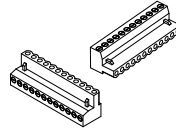

CONN, TERM BLOCK/F 12 POS BLACK
673-017-012 (QTY 2)

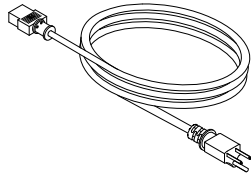

PWR CORD, MOLDED 6' BLK 3 COND
699-150-006 (QTY 1)

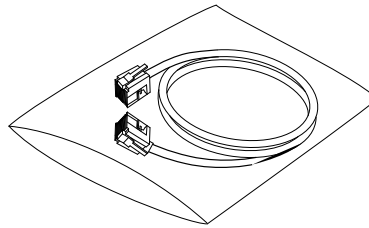

CABLE ASSEMBLY, RJ45/RJ45 18"
830-150-004 (QTY 1)

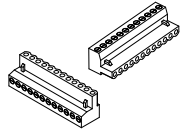

CONN, TERM BLOCK/F 12 POS ORANGE
673-017-112 (QTY 2)

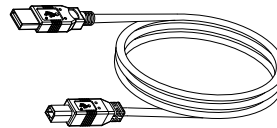

CABLE ASSY, USB A-B TYPE 6FT
830-153-001 (QTY 1)

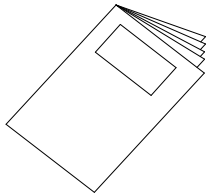

MANUAL, CONVERGE
800-151-880 (QTY 1)

CONVERGE USB Package Contents

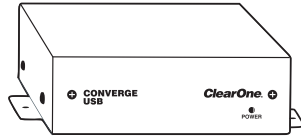

CONVERGE USB
910-151-806 (QTY 1)

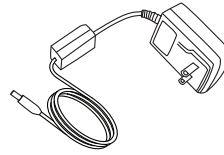

POWER SUPPLY USB
551-153-500-01G (QTY 1)

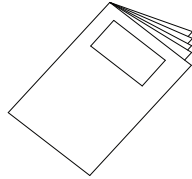

QUICK START GUIDE, CONVERGE USB
800-151-806 (QTY 1)



CONNECT TERMINAL BLOCK/F 6 POS
673-017-006 (QTY 1)

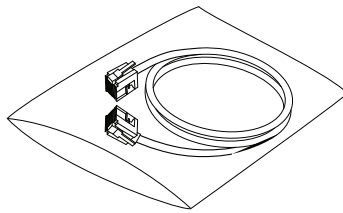

CABLE ASSEMBLY, RJ45/RJ45 25'
830-001-025L (QTY1)

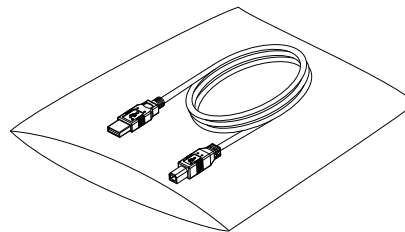

CABLE ASSY, USB A-B TYPE 6FT
830-153-001 (QTY 1)

CONNECT CobraNet/Dante Package Contents

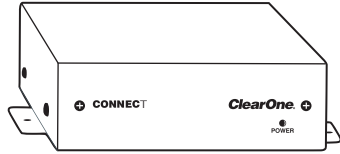

CONNECT CobraNet/Dante
910-151-805 (QTY 1)
or
910-151-807 (QTY 1)

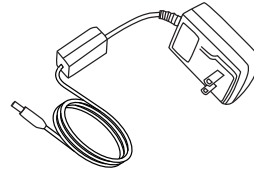

POWER SUPPLY USB
551-153-500-01G (QTY 1)

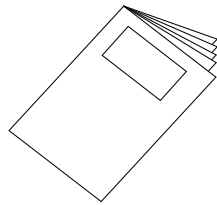

QUICK START GUIDE, CONNECT Cobranet/Dante
800-000-000-20-01 (QTY 1)
or
QSG-0017-001 (QTY 1)

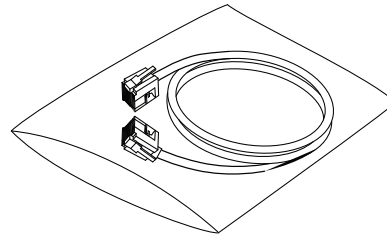

CABLE ASSEMBLY, RJ45/RJ45 25"
830-001-025L (QTY 1)

Beamforming Microphone Array

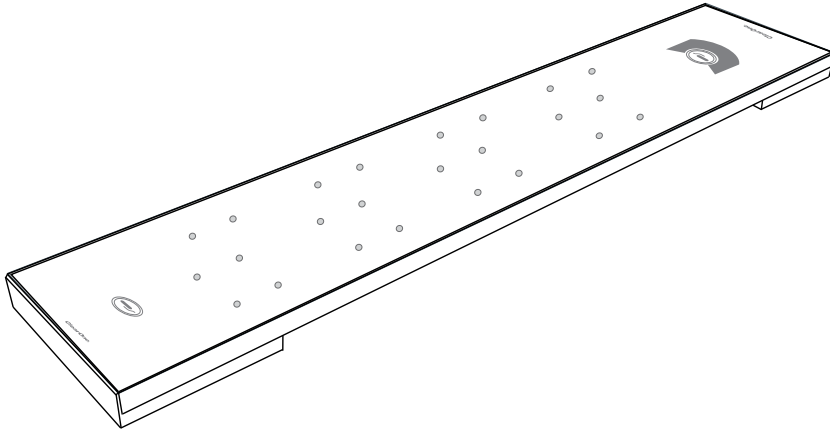

The Beamforming Microphone Array requires a separately ordered PoE power supply and cable kit and a ceiling mount kit as listed below:

- 910-001-003: Beamforming Microphone Array with 4 cable retention clips
- 910-001-004: PoE Power Supply & Cables Kit for Beamforming Microphone Array
- 910-001-005-12: Ceiling Mount kit with 12-inch spanner for Beamforming Microphone Array
- 910-001-005-24: Ceiling Mount kit with 24-inch spanner for Beamforming Microphone Array

CONTROLS AND CONNECTIONS

Refer to the following diagrams and descriptions for CONVERGE Pro front panel controls and back panel connectors.

CONVERGE Pro Front Panels

CONVERGE Pro 880 Front Panel

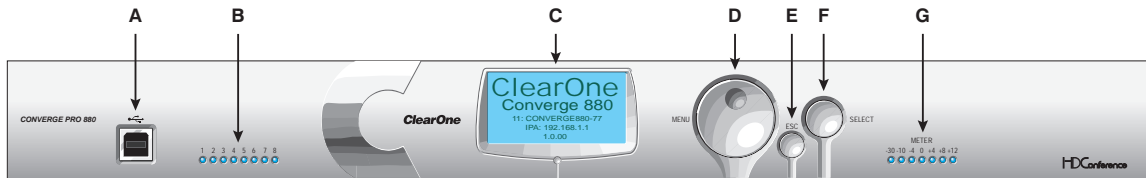

CONVERGE Pro 880T Front Panel

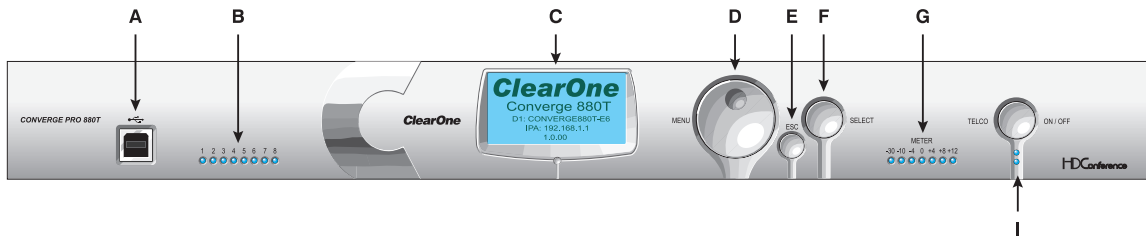

CONVERGE Pro 880TA Front Panel

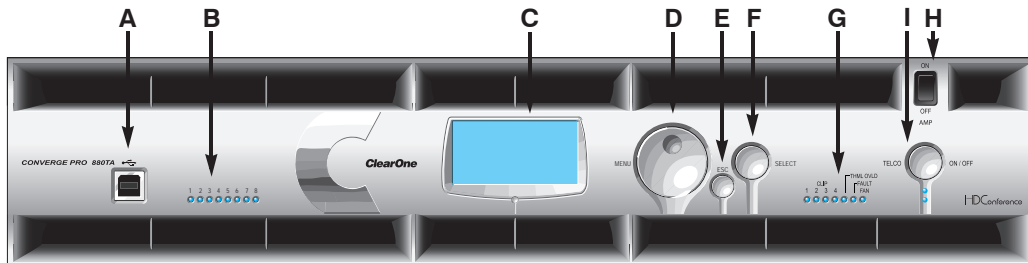

CONVERGE Pro 840T Front Panel

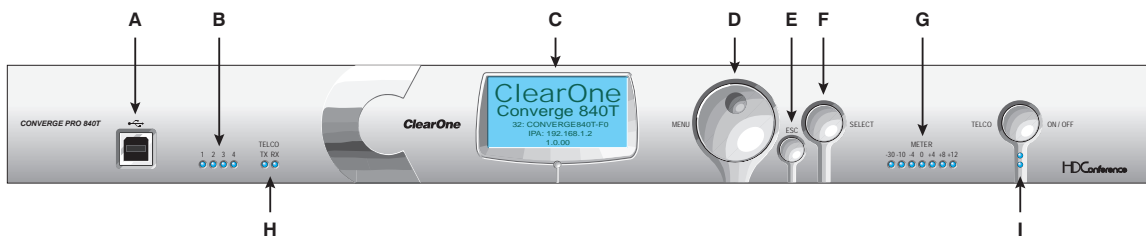

CONVERGE Pro 8i Front Panel

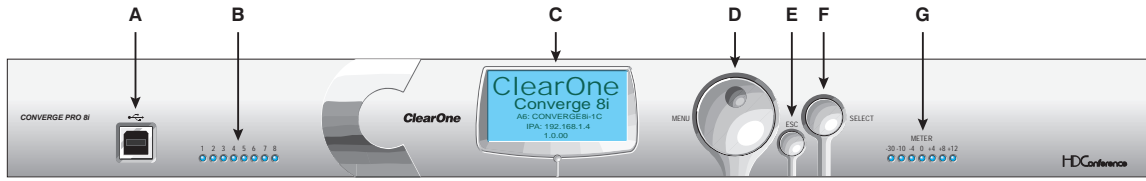

CONVERGE Pro TH20 Front Panel

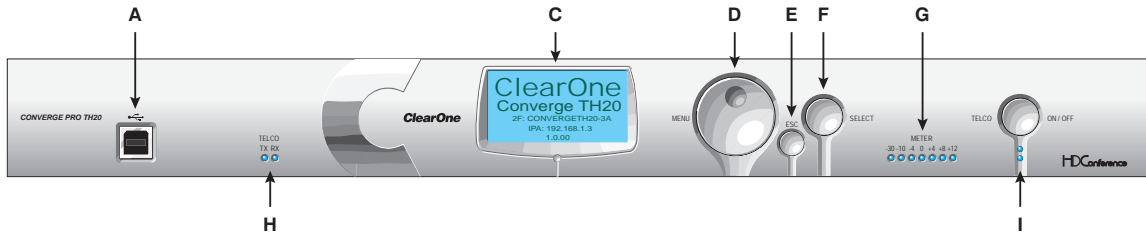

CONVERGE Pro VH20 Front Panel

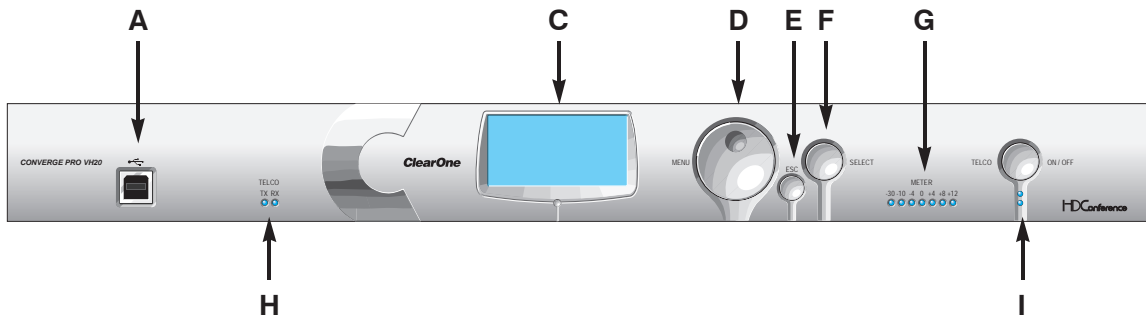

CONVERGE Pro SR1212 Front Panel

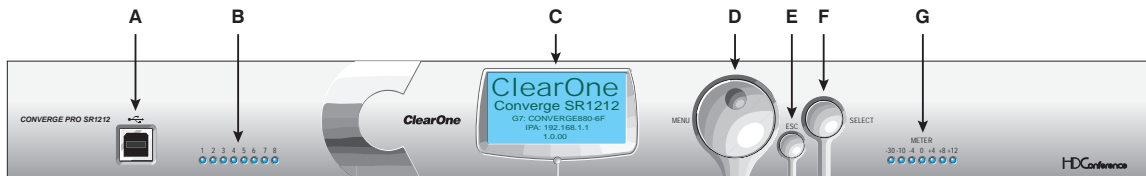

CONVERGE Pro SR1212A Front Panel

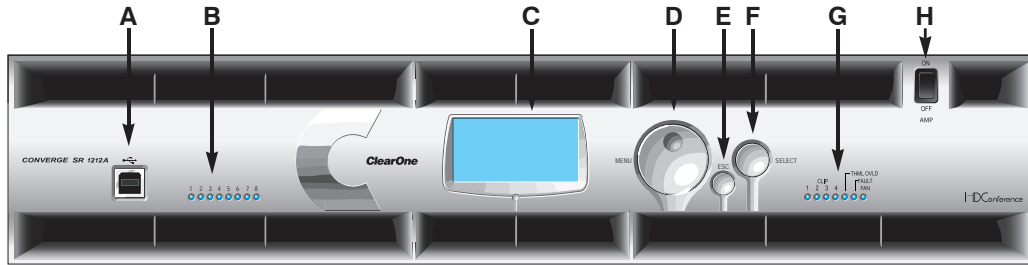

CONVERGE Pro Front Panel Control Descriptions

- A. USB Type B Port:** Provides convenient front panel connectivity for laptops and PCs.
- B. Microphone-On LEDs:** Indicate microphone gate status and mute state.
- C. LCD Display:** Shows model number, unit name, IP address, firmware version, menu pages, menu options, configuration settings, and parameter values.
- D. Menu Dial:** Navigates the CONVERGE Pro LCD programming menu and enables you to modify basic configuration settings.
- E. ESC Button:** Returns you to the previous screen on the LCD display.
- F. Select Button:** Displays the CONVERGE Pro LCD programming menu and selects the highlighted option.
- G. LED Bar Meter:** Displays the audio level of a selected input, output, processing, or fader channel. Default meters: 880-Output 12, 880T-Output 12, 840T-Output 8, 8i-Mic 1, TH20-Telco Tx, VH20-VoIP Tx, SR1212-Output 12.
 - **AMP Fault Indicator LEDs**(880TA, SR1212A): Indicates amplifier faults:
 - » 1-4 indicates clip
 - » 5 indicates thermal overload
 - » 6 indicates fault
 - » 7 indicates fan on/off
 - **Telco/VoIP Tx Rx Indicators (840T, TH20, VH20):** Indicates transmit and receive activity during Telco/VoIP calls.
- H. Amplifier On/Off Switch (880TA, SR1212A):** Turns power to the amplifiers on or off.

NOTE (880TA, SR1212A): This does NOT disconnect power from the AC mains. To disconnect unit power from the mains, disconnect the unit's power cord from the mains socket. To reconnect power, plug the unit's power cord into the mains socket following all safety instructions and guidelines.
- I. Telco On/Off Button & LEDs:** This button connects/disconnects the communications line attached to the device while the LEDs indicate the connection status of the attached line (840T, TH20, VH20 (VoIP only), 880T, 880TA).

CONVERGE Pro Rear Panels

CONVERGE Pro 880 Rear Panel

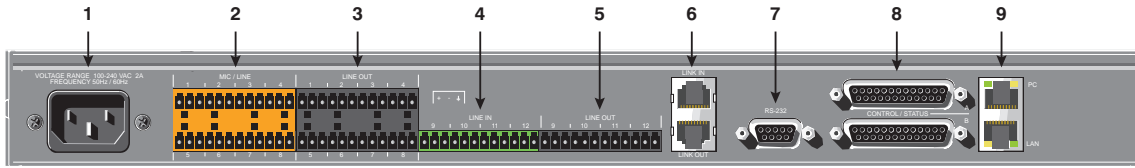

CONVERGE Pro 880T Rear Panel

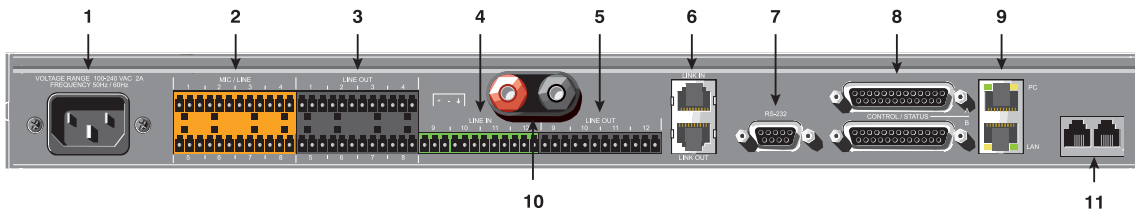

CONVERGE Pro 880TA Rear Panel

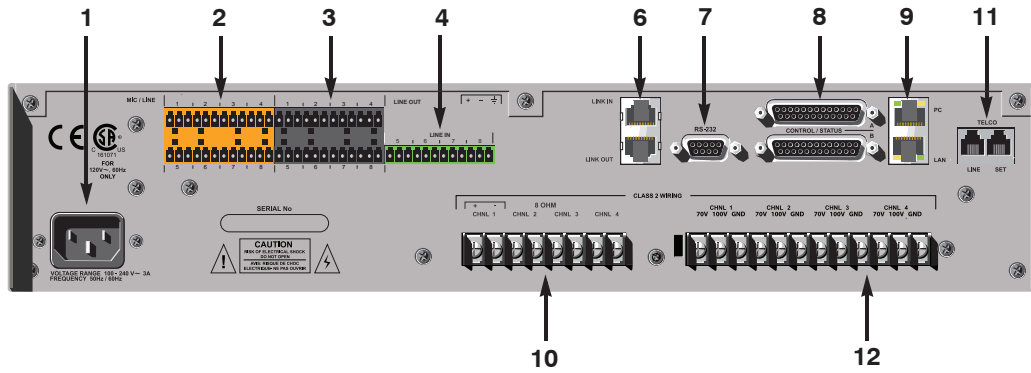

CONVERGE Pro 840T Rear Panel

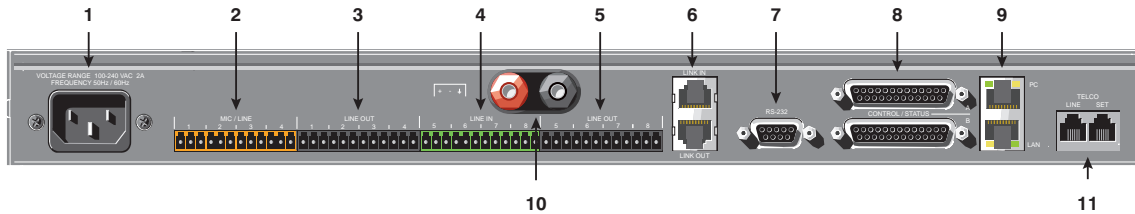

CONVERGE Pro 8i Rear Panel



CONVERGE Pro TH20 Rear Panel

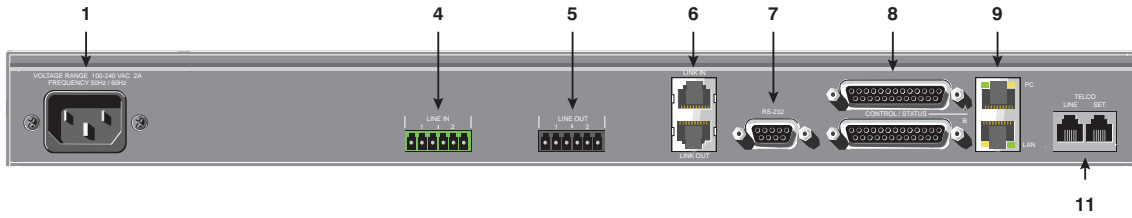

CONVERGE Pro VH20 Rear Panel

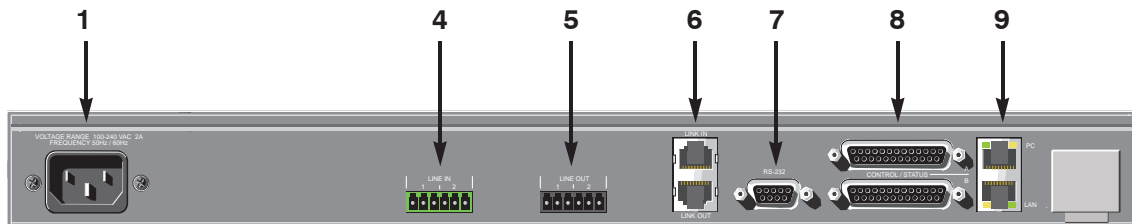

CONVERGE Pro SR1212 Rear Panel

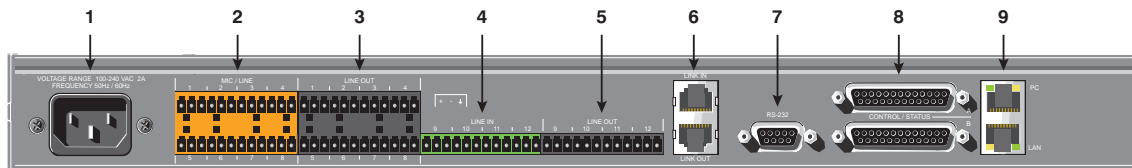

CONVERGE Pro SR1212A Rear Panel

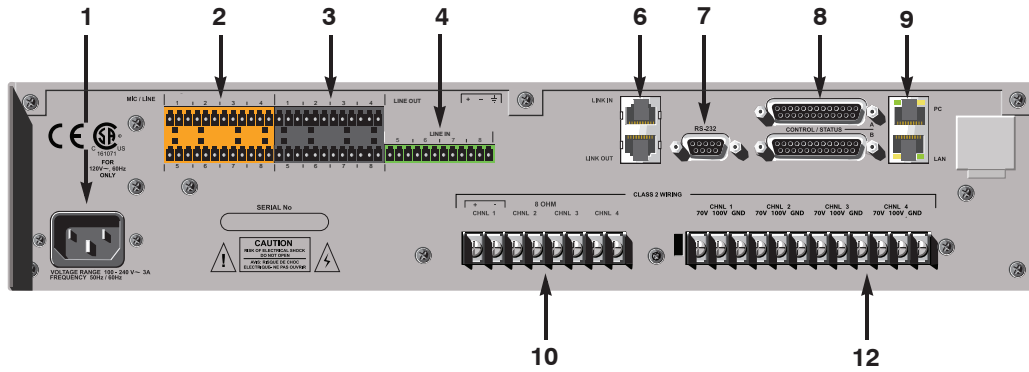

CONVERGE Pro Rear Panel Connectors

1. **AC Power:** IEC connector, 100 – 240VAC auto-adjusting, 50/60Hz.

 **Warning:** This equipment must be connected to an AC mains socket outlet with a protective earthing connection. The third prong of this connector (ground) is an important safety feature. Do not attempt to disable this ground connection by using an adaptor or other method.

2. **Mic/Line Inputs:** Mini-terminal push-on block connector for any combination of microphone and/or line level inputs. (CONVERGE Pro 880: 8 inputs. CONVERGE Pro 880T: 8 inputs. CONVERGE Pro 880TA: 8 inputs. CONVERGE Pro 840T: 4 inputs. CONVERGE Pro 8i: 8 inputs. CONVERGE Pro TH20, VH20: 0 inputs. CONVERGE SR1212: 8 inputs. CONVERGE SR1212A: 8 inputs.)
3. **Line Outputs:** Mini-terminal push-on connector for line-level outputs (880, 880T, 880TA, 840T, SR 1212, SR 1212A).
4. **Line Inputs:** Mini-terminal push-on block connector for line level inputs only. (CONVERGE Pro 880: 4 inputs. CONVERGE Pro 880T: 4 inputs. CONVERGE Pro 880TA: 4 inputs. CONVERGE Pro 840T: 4 inputs. CONVERGE Pro 8i: 4 inputs. CONVERGE Pro TH20, VH20: 2 inputs. CONVERGE SR1212: 4 inputs. CONVERGE SR1212A: 4 inputs.)
5. **Line Outputs:** Mini-terminal push-on block connector for line-level outputs (880, 880T, 840T, TH20, VH20, SR1212).
6. **Link In and Link Out Ports:** Two RJ-45 E-bus (expansion bus) connectors used to connect multiple CONVERGE Pro units together to create a site. You can connect up to twelve CONVERGE Pro 840T/880/880T/880TA/8i/SR1212/SR1212A units, up to 16 CONVERGE Pro TH20/VH20 units, or any combination thereof, where the total number of microphone inputs does not exceed 96. Maximum cable length is 200 feet using Category 5 unshielded twisted pair cable.



WARNING: Use the **Link In** and **Link Out** ports with CONVERGE Pro Devices or Beamforming Microphone Array ONLY. Connecting ANY other devices to the Link In and Link Out ports, including ClearOne XAP or PSR1212 products, or Power Over Ethernet (PoE) devices, will result in severe equipment damage.

7. **RS-232 Serial Port:** Female DB9 connector for connecting to a laptop, computer, or remote control serial devices (such as AMX and Crestron controllers).

NOTE: CONVERGE Console software cannot connect via the RS-232 port; use USB or Ethernet.

8. **Control/Status A and B Ports:** Two female DB25 connectors used for GPIO interactions between CONVERGE Pro devices and external control devices (such as wall switches and push-to-talk microphones). This enables external devices and controller software to access the CONVERGE Pro command set, including common functions such as volume control, muting, room combining, and preset changes.
9. **PC and LAN Ethernet Ports:** Two RJ-45 10/100Mbps auto-sensing Ethernet ports. The LAN port connects CONVERGE Pro devices to a network. The PC port provides a pass-through network connection for use with a standard (not crossover) patch cable. The LEDs adjacent to each port indicate connection status and packet traffic activity.
10. **Speaker Posts (880T, 840T)/Amplifier Terminal Block (880TA, SR1212A):**
 - 880T, 840T -- Two post/banana plug connectors used to connect an external speaker (4Ω – 16Ω). Internal power amplifiers eliminate the need for an external power amplifier.

- 880TA, SR1212A -- 8 speaker terminals used to connect an external speaker (8Ω). Four, 35 Watt internal power amplifiers eliminate the need for an external power amplifier.

NOTE: To reduce risk of electrical shock and damage to equipment, never connect wiring or external equipment while the amplifier is power is on. Class 2 wiring is required. Maintain the correct polarity (+/-) on output connectors. (For example: Channel 1 positive (+) speaker lead connects to amplifier's channel 1 positive terminal. Channel 1 negative (-) speaker lead connects to amplifier's channel 1 negative terminal. Repeat this procedure for each channel.

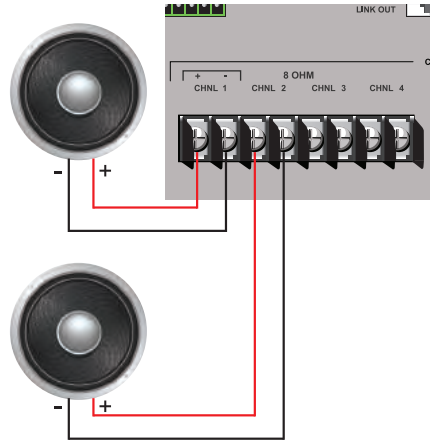

11. Telco Line and Telco Set Ports: Two RJ-11 connectors telephone ports. The Telco Line port connects an analog telephone line to CONVERGE Pro devices. The Telco Set port provides a pass-through connection for telephone handsets (880TA, 880T, 840T, TH20).

NOTE: The Telco Set port is not available for use when the telephone hybrid is off-hook.

12. Amplifier Terminal Block (880TA, SR1212A): 12 speaker terminals used to connect an external speaker (70/100 v). Four, 35 Watt internal power amplifiers eliminate the need for an external power amplifier.

NOTE: To reduce risk of electrical shock and damage to equipment, never connect wiring or external equipment while the amplifier is power is on. Class 2 wiring is required. Maintain the correct polarity on output connectors. (For example: Channel 1 70V/100V speaker lead connects to amplifier's channel 1 70V or 100V terminals. Channel 1 GND (or Common) speaker lead connects to amplifier's channel 1 GND terminal. Repeat this procedure for each channel.

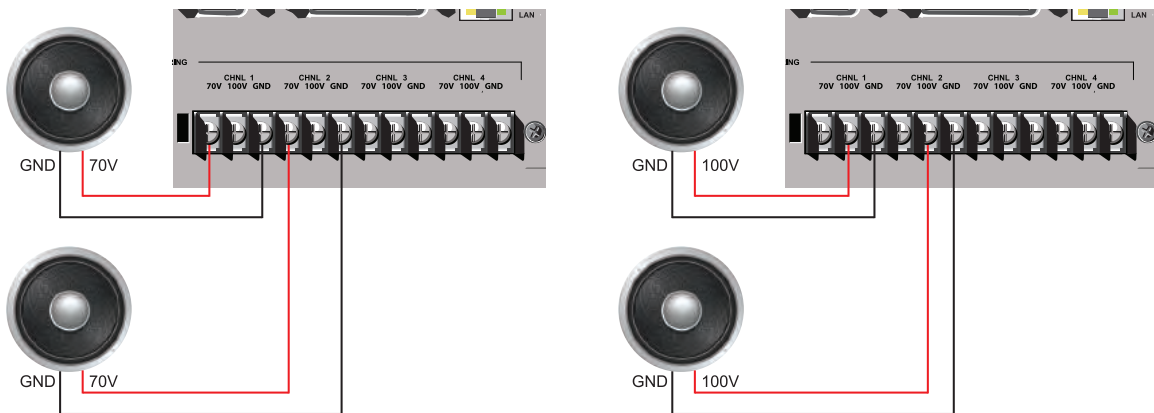

Beamforming Microphone Array Connections and Controls

Refer to the following diagrams and descriptions for Beamforming Microphone Array connections and controls.

Beamforming Microphone Array Connections

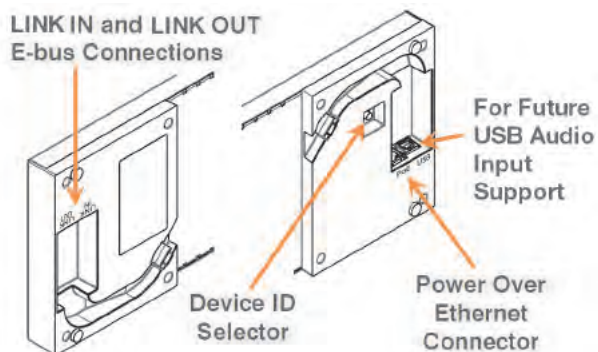

- 1. Link In and Link Out Ports:** Two RJ-45 E-bus (expansion bus) connectors are used to connect multiple CONVERGE Pro units or to daisy-chain Beamforming Microphone arrays together to create a site. 3 arrays per CONVERGE Pro unit are supported and up to 16 Beamforming Microphone Arrays can be daisy-chained in the site.



WARNING: Use the **Link In** and **Link Out** ports **ONLY** with CONVERGE Pro and/or Beamforming Microphone Array devices. Connecting **ANY** other devices to the Link In and Link Out ports, including ClearOne XAP or PSR1212 products, or Power Over Ethernet (PoE) devices, will result in severe equipment damage.

- 2. Power over Ethernet (PoE):** The PoE connection is only for power, not control. Power must be provided through a standard Power-over-Ethernet switch or through an external PoE power supply for individual units; no daisy-chain power is allowed.
- 3. Device ID Selector:** Set each Beamforming Microphone Array unit within the site to a unique ID using the Device ID selector rotary switch on the back of the unit. (Range 0-F)

Beamforming Microphone Array Controls

The Beamforming Microphone Array is controlled mainly through CONVERGE Console except for mute buttons on the device that toggle the microphone array mute on and off. The mute buttons illuminate red when the microphone array is muted and blue when the array is unmuted. This action can also be software controlled through CONVERGE Console.

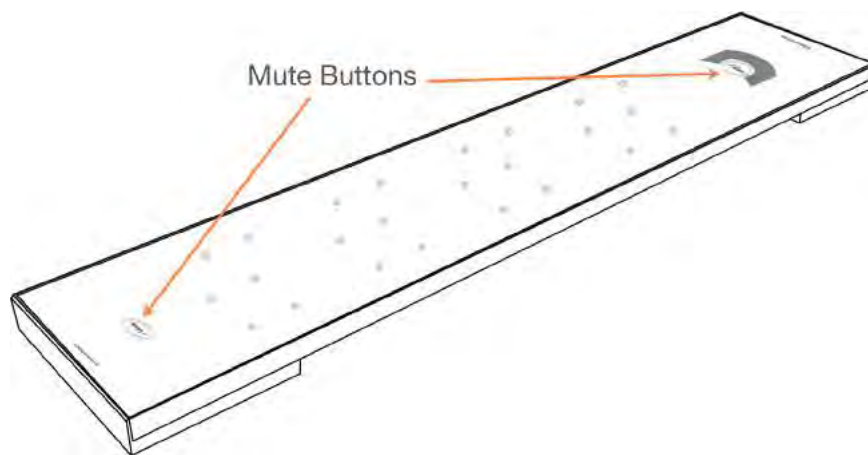

CONNECT CobraNet Connections and Controls

Refer to the following diagrams and descriptions for CONNECT CobraNet connections and controls.

CONNECT CobraNet Connections

Set each CONNECT CobraNet unit to a unique ID using the Device ID selector rotary switch on the back of the unit. (Range 0-7) Each CONNECT unit in any site needs a unique Device ID. Only 8 units are allowed in any site.

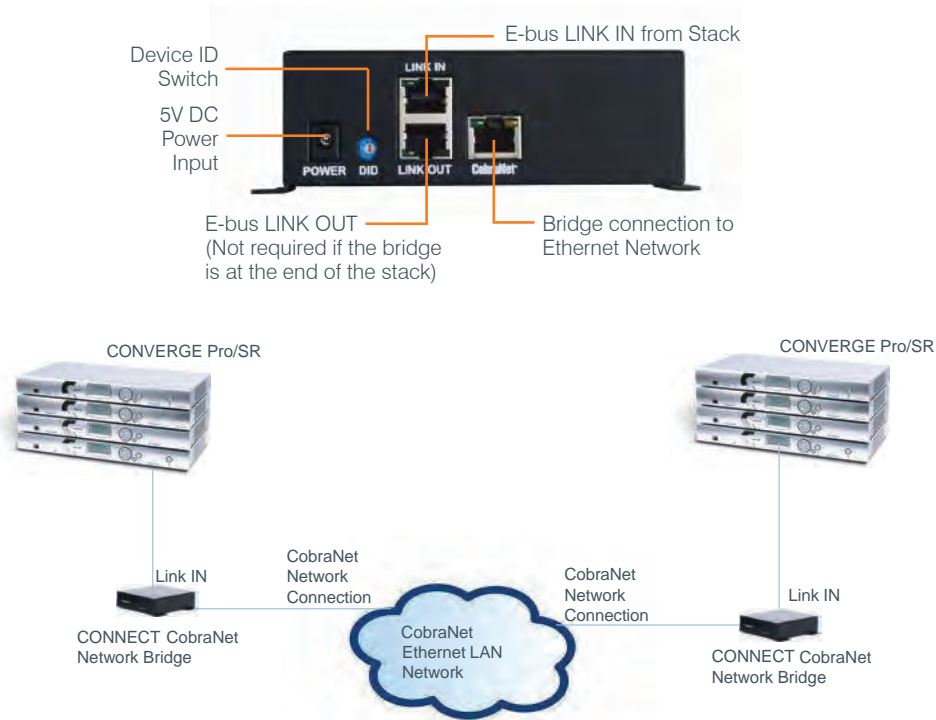

Connecting CONVERGE Pro/SR units in different rooms that are on different networks using multiple CobraNet network bridges

CONNECT CobraNet Control

The CONNECT CobraNet network audio bridges are controlled mainly through CONVERGE Console where configuration is made and device identification (set matching the Device ID switch) is established in the stack.

CONNECT Dante Connections and Controls

Refer to the following diagrams and descriptions for CONNECT Dante connections and controls.

CONNECT Dante Connections

Set each CONNECT Dante unit to a unique ID using the Device ID selector rotary switch on the back of the unit. (Range 0-7) Each CONNECT unit in any site needs a unique Device ID. Only 8 units are allowed in any site.

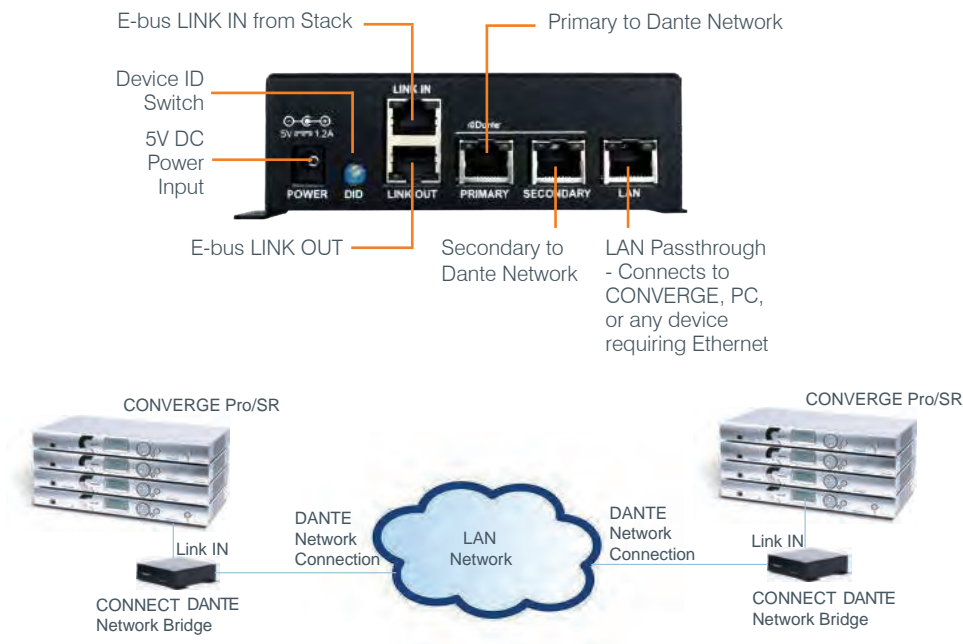

CONNECT Dante Control

The Dante Controller software, provided by Audinate™, is used to discover, control, and configure all devices and services on the Dante network including the CONNECT Dante network bridges. This software and its documentation can be obtained from the ClearOne website:

http://www.clearone.com/resources#professional_audio

The CONVERGE Console software is used to route audio to/from Expansion Bus S-Z. Dante channels 1-8 are associated with Expansion Bus channels S-Z on both the input and output cells of the matrix.

NOTE: You are unable to route audio across two Dante units without the Audinate Controller software.

CONVERGE USB

Refer to the following diagrams and descriptions describe the CONVERGE USB connections and controls when used as an USB interface and as and E-bus extender.

CONVERGE USB Interface Connections

Connect each CONVERGE USB unit to the site via the E-bus connections.

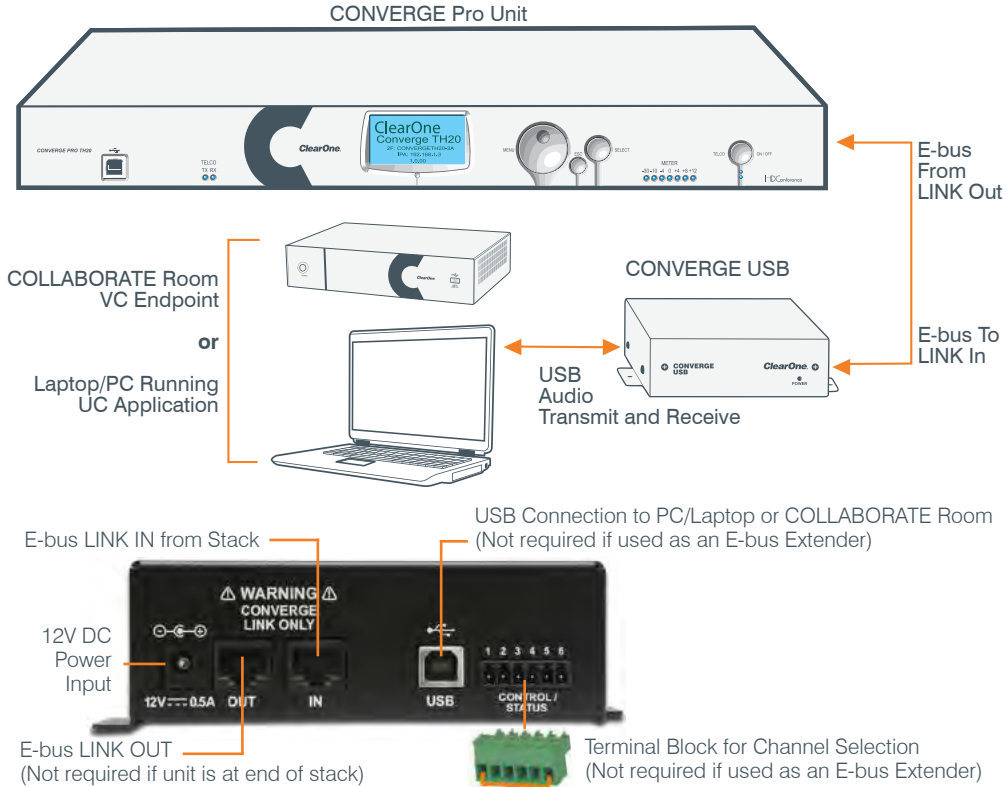

The E-bus channels upon which the Tx/Rx audio will be available is determined by the jumpers placed in the Channel Selection Terminal Block.



Routing the CONVERGE USB Interface Connections

Using CONVERGE Console, route each CONVERGE USB Tx/Rx signal within the site to match the E-bus connections as selected by the terminal block. This is done on the Matrix screen for the site.

In the example below a terminal block jumper is between pins 1 and 6, so the CONVERGE Pro channels are M for transmit and N for receive. These must then be routed to the desired inputs and outputs. The following two screen captures show audio from the CONVERGE USB on Channel M going to Output 8, and Channel N receiving audio from Input 9 then sending it to the CONVERGE USB.

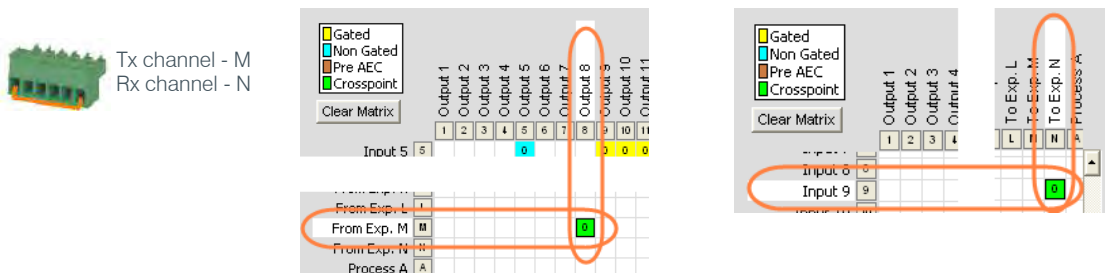

Using the CONVERGE USB as an E-bus Extender

The CONVERGE USB application as an E-bus extender can, for example, be up to 200 feet from the stack, then re-send the E-bus signals for up to another 200 feet to the next E-bus component.

The following diagram illustrates the use of the CONVERGE USB as an E-bus extender.

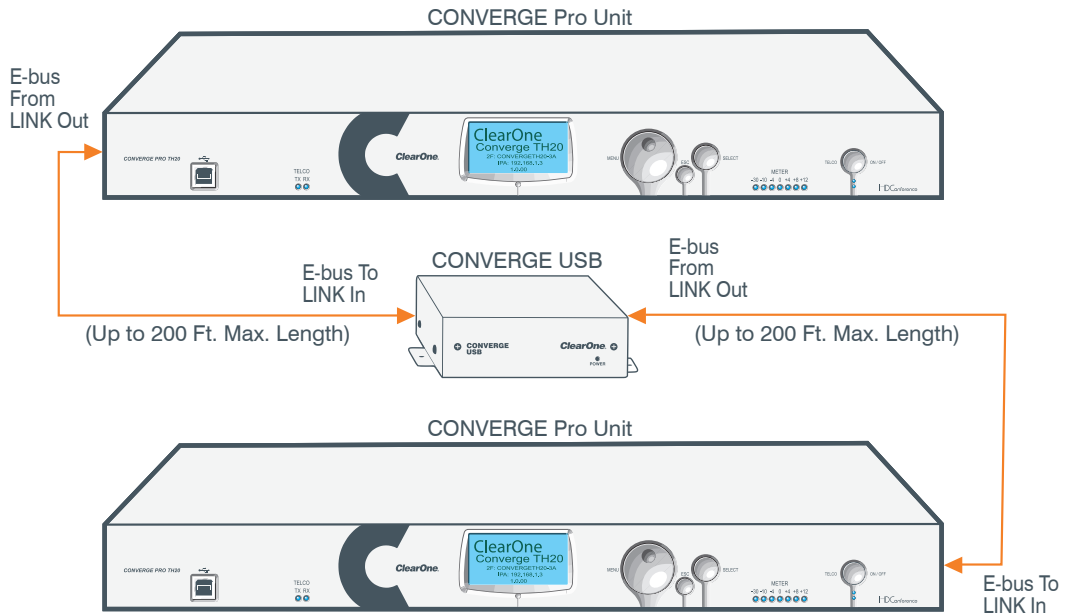

NOTE: Link Channel Selection and routing is NOT required when the CONVERGE USB is used only as an E-bus extender with no USB Tx/Rx channels used.

CHAPTER 2: EXPANSION BUS & LCD PROGRAMMING

EXPANSION BUS

The Expansion Bus (E-bus) allows you to connect multiple CONVERGE/CONVERGE-Pro units together to create powerful audio and conferencing solutions for any size venue. The E-bus is a proprietary digital audio bus that provides control and audio data links between devices.

Expansion Bus Connections

Using the E-bus Link In and Link Out ports, you can connect up to 34 CONVERGE Pro 880/880T/880TA/840T/8i and CONVERGE SR1212/SR1212A units, and 16 Beamforming Microphone Arrays, and up to 16 CONVERGE Pro TH20 and VH20 units, where the total number of microphone inputs does not exceed 96.

Connect units in daisy-chain fashion (as shown below) using the 18" straight-through patch cable included with each unit (Part # 830-150-004). For larger distances between units, use CAT 5 twisted pair cable with RJ-45 connectors. The maximum cable length between connected units is 200 feet (61 meters).

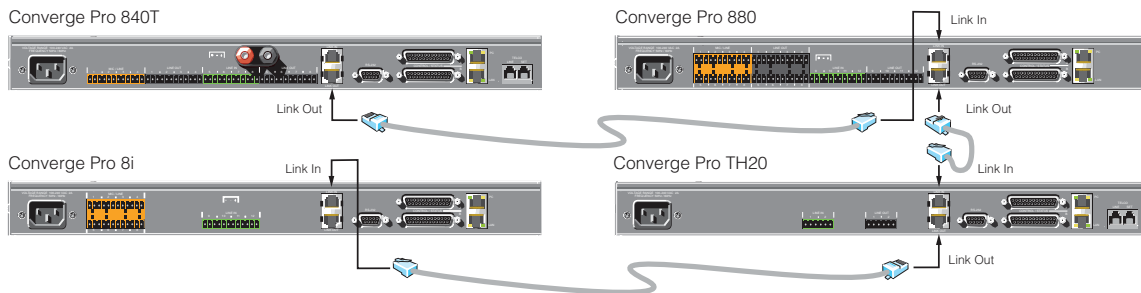

Audio and Control Buses

The E-bus allows audio routing between source devices and destination devices on the E-bus network. The E-bus contains 18 independent digital audio buses labeled I–Z, which can route mic or line inputs in any combination across the E-bus network. The E-bus also contains four PA adapt/acoustic echo cancellation reference buses, six global gating buses, and one control bus.

S-Z Buses: These eight buses are line input mixer buses. They are used to route auxiliary audio, such as from a CD player, VCR, or CONNECT network bridges to and from other units on the network. These buses are also used as mic mixer buses when NOM count is not required.

I-R Buses: These ten audio buses are generally used for routing microphone audio between CONVERGE/CONVERGE Pro devices. Information about the number of gated microphones (NOMcount) and other relevant information for the microphone mixers are tracked for microphones routed to these buses. By default, all microphones are routed to the O bus.

PA Adapt/Acoustic Echo Cancellation Reference Buses: These buses allow an input from a CONVERGE/CONVERGE Pro device to reference an output on another linked device for AEC and PA Adaption. See *AEC Reference/PA Adapt Reference* and *AEC* for more information.

Global Gating Groups A-F: These buses are microphone gating groups that support first-mic priority, maximum number of mics, etc. and work across all linked CONVERGE/CONVERGE Pro devices. Unlike the audio buses, they contain only mic status and gate parameters. See the *Gating and Gating Group* topics for more information.

Control Bus: The control bus is an independent channel from the E-bus's audio channel. This allows control information to pass even if the units are not using the audio link. All models support the use of the CONVERGE/CONVERGE Pro serial command set through the control bus.

DEVICE ID'S

Device ID's provide unique identifiers for all units that are linked together using the E-bus. After making Expansion Bus connections, you must set a unique Device ID number for all units of the same Device Type on the E-bus.

Device Types and ID's

Device Types and Device ID's by model are as follows:

Model	Device Type	Device ID Range
880	1	0-B
TH20	2	0-F
VH20	E	0-F
840T	3	0-B
8i	A	0-B
880T	D	0-B
880TA	H	0-B
SR1212	G	0-B
SR1212A	I	0-B
Beamforming Microphone Array	N	0-F
CONNECT CobraNet/Dante		0-7

NOTE: All models ship from the factory with a default DID of 0.

Assigning Device ID's

Use the following procedure to assign device ID's using the front panel controls:

1. Press the **Select** button on the front panel. The **CONVERGE Menu** appears.

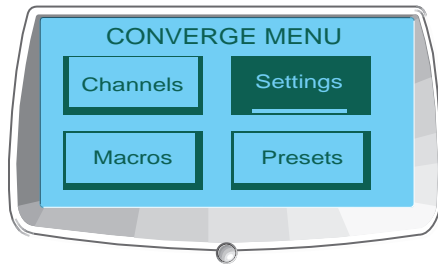

2. Use the **Menu Dial** to highlight the **Settings** menu. Press the **Select** button. The **Settings** menu appears.

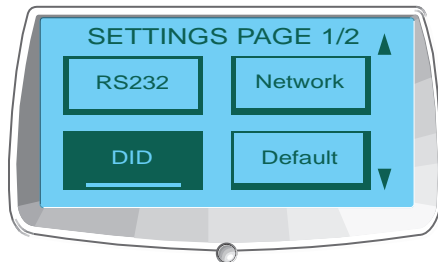

3. Use the **Menu Dial** to highlight **DID**. Press the **Select** button. The **Device ID** menu appears.

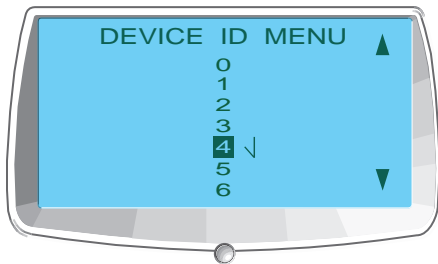

4. Use the **Menu Dial** to highlight the desired value. Press the **Select** button to select it.
5. The **Change DID Menu** prompt appears. Choose **Yes** to set the selected DID value, or **No** to return to the **Device ID** menu.

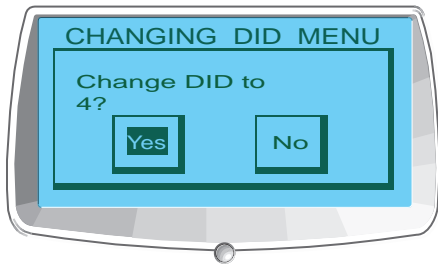

6. Press **Esc** until to return to the **Settings** menu.
7. Repeat this process for each device on the E-bus network.

NOTE: You can also set Device IDs in the Unit Properties screen in Console (when disconnected). However, DID assignments made in Console must match the DID assignments made using the front panel.

Assigning Beamforming Microphone Array Device ID's

Set each Beamforming Microphone Array unit within the site to a unique ID using the Device ID selector rotary switch on the back of the unit. (Range 0-F)

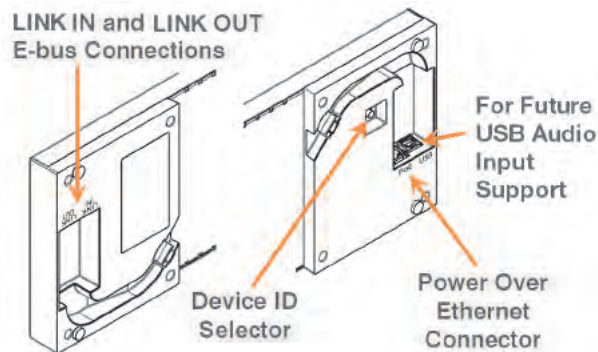

Assigning CONNECT Network Bridge Device ID's

Set each CONNECT unit within the site to a unique ID using the Device ID (DID) selector rotary switch on the back of the unit. (Range 0-7)



LCD PROGRAMMING OVERVIEW

LCD Programming allows you to make simple configuration adjustments using front panel controls (shown below).

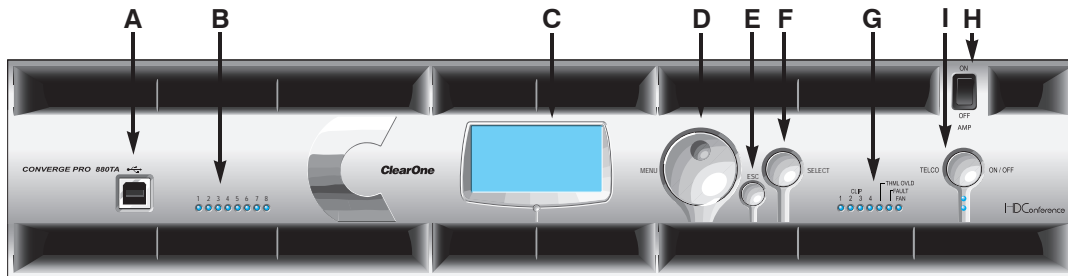

- A. USB Type B Port:** Provides convenient front panel connectivity for laptops and PCs.
- B. Microphone-On LEDs:** Indicate microphone gate status and mute state.
- C. LCD Display:** Shows model number, unit name, IP address, firmware version, menu pages, menu options, configuration settings, and parameter values.
- D. Menu Dial:** Navigates the CONVERGE Pro LCD programming menu and enables you to modify basic configuration settings.
- E. ESC Button:** Returns you to the previous screen on the LCD display.
- F. Select Button:** Displays the CONVERGE Pro LCD programming menu and selects the highlighted option.
- G. LED Bar Meter:** Displays the audio level of a selected input, output, processing, or fader channel. Default meters: 880-Output 12, 880T-Output 12, 840T-Output 8, 8i-Mic 1, TH20-Telco Tx, VH20-VoIP Tx, SR1212-Output 12.
 - **AMP Fault Indicator LEDs**(880TA, SR 1212A): Indicates amplifier faults:
 - » 1-4 indicates clip
 - » 5 indicates thermal overload
 - » 6 indicates fault
 - » 7 indicates fan on/off
 - **Telco/VoIP Tx Rx Indicators (840T, TH20, VH20):** Indicates transmit and receive activity during Telco/VoIP calls.
- H. Amplifier On/Off Switch (880TA, SR 1212A):** Turns power to the amplifiers on or off.

NOTE (880TA, SR 1212A): This does NOT disconnect power from the AC mains. To disconnect unit power from the mains, disconnect the unit's power cord from the mains socket. To reconnect power, plug the unit's power cord into the mains socket following all safety instructions and guidelines.

- I. Telco On/Off Button & LEDs:** This button connects/disconnects the communications line attached to the device while the LEDs indicate the connection status of the attached line (840T, TH20, VH20 (VoIP) only),

880T, 880TA).

In addition to making configuration adjustments from the front panel, you can also run macros and execute presets. For more information on using front panel controls, see *Controls and Connections*.

Adjusting LCD Menu Parameters

Use the following procedure to adjust LCD Menu parameters:

1. Press the **Select** button to access the **CONVERGE Menu**.
2. Scroll to the parameter you want to adjust using the **Menu Dial**.
3. Press the **Select** button to select the parameter. The parameter will stop flashing when selected.
4. Select the value for the parameter using the **Menu Dial**.
5. Press the **Select** button to save the parameter value. To discard the change and return to the previous menu, press the **Esc** button.

NOTE: Use the Console software in Configuration Mode for advanced configuration tasks.

LCD Menu Tree

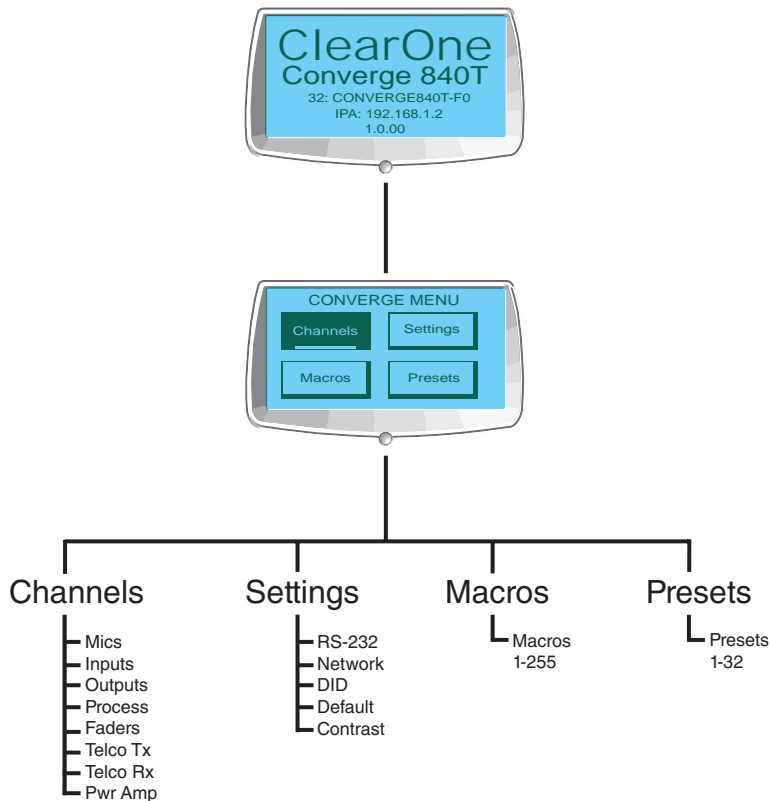

As shown above, the main menus on the LCD display are:

- Channels
- Settings
- Macros
- Presets

LCD Default Display

When you power up a CONVERGE/CONVERGE Pro unit, the LCD display reads **Initializing**. If an error occurs, contact ClearOne Technical Support. When initialization is complete, **ClearOne CONVERGE[Model Number]** appears on the LCD panel, along with the device type, device ID, device name, IP address, and firmware revision level as shown below.

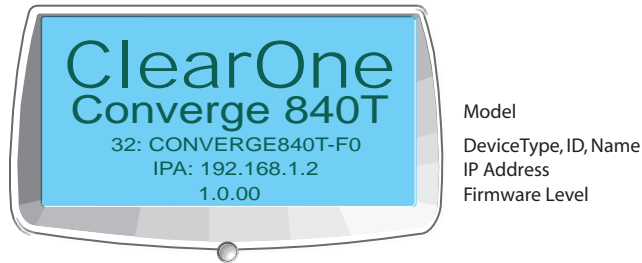

To access the LCD menu, press the **Select** button. The **CONVERGE Menu** appears as shown below.

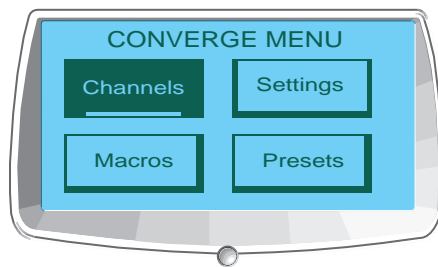

Front Panel Lock

Using Console, you can create a PIN code and lock the front panel to prevent unauthorized access to LCD menu functions. When the lock feature is enabled and the front panel is unlocked, it will automatically re-lock after 3 minutes of inactivity. See the *Unit Properties* topic for instructions on how to enable the lock feature.

For more information, see the *Table of Contents* for these related topics:

- **Macros**
- **Presets**
- **Controls and Connections**
- **Console Configuration Mode**
- **Mic Input Settings**
- **Line Input Settings**
- **Telco/VoIP Rx Settings**
- **Telco/VoIP Tx Settings**
- **Processing Settings**
- **Output Settings**
- **LCD Channels Menu**
- **LCD Settings Menu**
- **LCD Macros Menu**
- **LCD Presets Menu**
- **Device IDs**
- **Unit Properties**

LCD CHANNELS MENU

The **LCD Channels Menu** allows you to adjust the gain level and turn mute on or off for all channels.

Accessing the Channels Menu

To access the **Channels** menu, press the **Select** button on the front panel, use the **Menu Dial** to select **Channels**, and press the **Select** button.

The **Channels** menu appears as shown below:

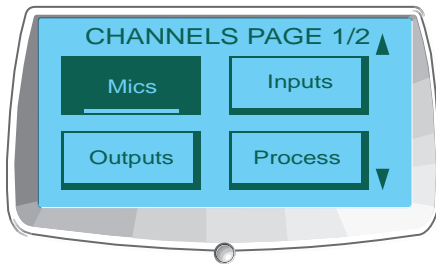

Channels menu options (i.e. channel types) include:

- **Mics**
- **Inputs**
- **Outputs**
- **Process**
- **Faders**
- **Telco/VoIP Tx**
- **Telco/VoIP Rx**
- **Pwr Amp**

After you select an option, a list of all available channels of that type is displayed. Use the **Menu Dial** to select the channel you want to configure and press the **Select** button. The **Channels** display appears.

Channel Display

The channel display is identical for every channel type, with the exception of the channel ID and channel label, which both vary depending on the channel selected.

As shown below, the display includes a peak-level meter, a peak dB reading, a gain level adjustment box, and a mute selector.

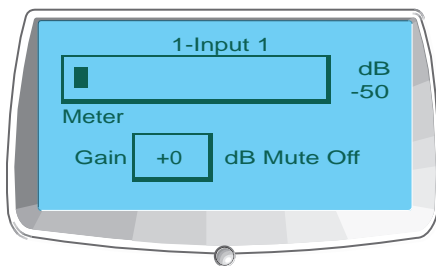

Setting Channel Gain and Mute

The procedure for setting gain and mute is the same for all channel types:

1. Use the **Menu Dial** to highlight **Gain** or **Mute**
2. Press the **Select** button
3. Select the desired value using the **Menu Dial**
4. Press the **Select** button to set the selected value
5. Press the **Esc** button to return to the **Channels** menu

NOTE: When mute is set to on for a mic input channel, the Microphone-On LED for that channel illuminates red on the front panel.

For more information, see the *Table of Contents* for these related topics:

- **LCD Programming Overview**
- **LCD Channels Menu**
- **LCD Settings Menu**
- **LCD Macros Menu**
- **LCD Presets Menu**
- **Controls and Connections**
- **Mic Input Settings**
- **Line Input Settings**
- **Output Settings**
- **Process Settings**
- **Fader Settings**
- **Telco/VoIP Tx Settings**
- **Telco/VoIP Rx Settings**
- **Pwr Amp**

LCD SETTINGS MENU

The **LCD Settings Menu** allows you to configure serial port settings and Device IDs, view network IP settings, change the LCD contrast level, and restore factory default settings for a unit.

Accessing the Settings Menu

To access the **Settings** menu, press the **Select** button on the front panel, use the **Menu Dial** to select **Settings**, and press the **Select** button.

The **Settings** menu appears as shown below:

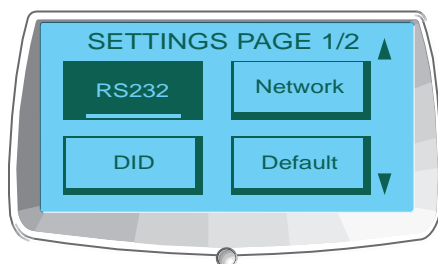

Settings menu options include:

- **RS-232**
- **Network**
- **DID**
- **Default**
- **Contrast**
- **Version**
- **SIP***

***VH20 Only**

These options are described in the following sections.

RS-232

There are two parameters in the RS-232 menu: Baud Rate and Flow Control. To change these settings, use the following procedure:

1. Use the **Menu Dial** to highlight **Baud Rate** or **Flow Control**
2. Press the **Select** button
3. Select the desired value using the **Menu Dial**
4. Press the **Select** button to set the selected value
5. Press the **Esc** button to return to the **Settings** menu

You can also use the Comm tab of the Unit Properties screen to change these settings.

Baud Rate

This parameter allows you to set the baud rate to 9.6kbps, 19.2kbps, 38.4kbps, 57.6kbps, or 115.2kbps. The default is 57.6 kbps. Select the baud rate you want to use, then press the **Select** button. A message appears on the LCD display indicating the change is in progress, and another indicating the change is complete. When finished, the display returns to the RS-232 sub-menu.

Flow Control (Hardware)

All models use the RTS and CTS pins on the RS-232 port to regulate the transmission and reception of data. You can enable or disable flow control on the front panel, and set the flow control type in the Unit Properties window in Console.

If you select **On** (default) from the front panel LCD menu, select **Hardware** as the flow control type in the **Unit Properties** window. If you disable flow control on the front panel, select **None** in the **Unit Properties** window. When None is selected, the unit ignores flow control, and the relies on the connected external control device to ensure data is not lost.

NOTE: ClearOne recommends that you leave Flow Control enabled and connect all DB9 pins to avoid communication errors.

Network

The **Network** submenu displays the unit name, IP address, Gateway, and Subnet Mask settings for the unit. You cannot change any of these settings from the Network submenu. Use the Unit Properties screen in Console to change these settings.

DID

The **DID** submenu allows you to select a Device ID for the unit. Select the DID you want to use, press the **Select** button. Answer **Yes** to the prompt to change the DID, or **No** to keep the existing setting.

You can also use the General tab of the Unit Properties screen in Console to change this setting when disconnected from the unit. However, DID assignments made in Console must match DID assignments made using the front panel.

Default

Default restores ALL settings to their factory default values. Answer **Yes** to the prompt to restore default settings, or **No** to retain the existing settings.

Contrast

Contrast allows you to change the LCD contrast level. Use the **Menu Dial** to adjust the contrast level, then press the **Select** button to save it.

Version

Version displays all relevant version data related to the device.

SIP

SIP Displays which Proxy Settings are currently enabled on the VH20.

For more information, see the *Table of Contents* for these related topics:

- **LCD Programming Overview**
- **LCD Channels Menu**
- **LCD Macros Menu**
- **LCD Presets Menu**
- **Site Properties**
- **String Tab**
- **Unit Properties**

LCD MACROS MENU

The **LCD Macros Menu** allows you to run macros from the front panel. To record Macros, use the Macro Tab in Console.

Accessing the Macros Menu

To access the Macros menu, press the **Select** Button on the front panel, use the **Menu Dial** to select **Macros**, and press the **Select** Button.

The **Macro Menu** appears as shown below:

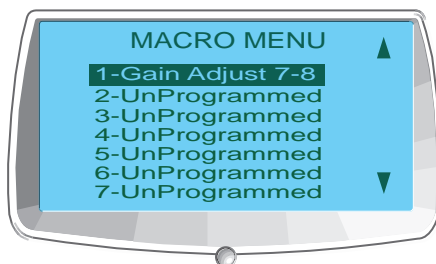

Executing Macros

Use the following procedure to run macros from the front panel LCD display:

1. Use the **Menu Dial** to highlight the macro you want to run
2. Press the **Select** button
3. Answer **Yes** at the prompt that appears to run the selected macro, or **No** to cancel.
4. Press the **Esc** button to return to the main LCD menu.

You can also run macros using the Macro tab or the Services menu in Console.

For more information, see the *Table of Contents* for these related topics:

- **LCD Programming Overview**
- **LCD Settings Menu**
- **LCD Channels Menu**
- **LCD Presets Menu**
- **Macro Tab**

LCD PRESET MENU

The **LCD Preset Menu** allows you to execute presets from the CONVERGE Pro front panel. To create presets, use Console in Preset Mode.

Accessing the Presets Menu

To access the menu, press the **Select** button on the front panel, use the **Menu Dial** to select **Presets**, and press the **Select** Button.

The **Preset Menu** appears as shown below:

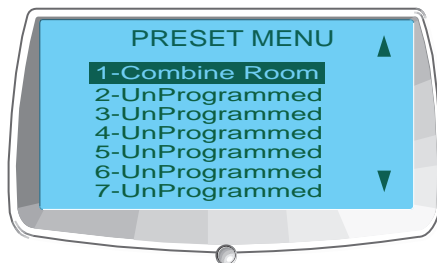

Executing Presets

Use the following procedure to execute presets from the front panel LCD display:

1. Use the **Menu Dial** to highlight the preset you want to execute
2. Press the **Select** button
3. Answer **Yes** at the prompt that appears to run the selected preset, or **No** to cancel
4. Press the **Esc** button to return to the main LCD menu

You can also run presets from the Services menu while Console is in Configuration Mode.

For additional information, refer to the *Table of Contents* for these related topics:

- **LCD Programming Overview**
- **LCD Settings Menu**
- **LCD Channels Menu**
- **Preset Mode**
- **Console Overview**
- **Services Menu Overview**
- **Configuration Mode Overview**

CHAPTER 3: CONVERGE CONSOLE PROGRAMMING

INSTALLING CONVERGE CONSOLE

The CONVERGE Console software is designed for Windows operating systems.

1. Ensure that all other programs or applications are closed and disconnect any USB cables from all CONVERGE/CONVERGE Pro devices (you will reconnect them later).
2. Insert the **CONVERGE/CONVERGE Pro Installation & Documentation** CD into the CD or DVD-ROM drive.
3. If the Autorun feature is enabled on the PC, the CONVERGE/CONVERGE Pro Installation window opens automatically. Click the **CONVERGE Console Software** menu option on the left side of the screen to begin installation.
 - » If Autorun is not enabled, open **My Computer** navigate to the drive holding the CONVERGE/CONVERGE Pro Installation & Documentation CD. Double-click on the drive icon and launch **setup.exe**.
4. When the **CONVERGE/CONVERGE Pro Installation & Documentation CD** window appears, click the **CONVERGE Console Software** menu option on the left side of the screen.
5. The **CONVERGE Console Setup Wizard** appears. Press the **Next** button and navigate through the **License Agreement** and **Information** screens that appear.
6. At the **Select Installation Folder** window, choose the directory where you want to install Console. Press the **Disk Cost** button to analyze available and required free space (if needed).

NOTE: ClearOne recommends that you use the default directory when installing Console.

7. Press the **Next** button until installation starts.
8. Follow the wizard to proceed copy CONVERGE/CONVERGE Pro USB drivers onto your system.



NOTE: If you stop installation of this driver software, Windows will terminate USB device driver installation, however Console installation will continue to completion, and Console will function properly over IP. You will not be able to use Console over USB.

9. Follow the instructions that appear on-screen to complete installation.
10. When Console installation is complete, the CONVERGE Console  icon appears on your desktop. You can now start Console over IP by double-clicking the icon, or through the **All Programs > ClearOne Communications > CONVERGE Console** program group in the Windows **Start** menu.
11. To use a USB connection with Console, connect USB cables between the PC and the CONVERGE/CONVERGE Pro device.

NOTE: Windows automatically detects the device and begins the USB device driver installation. This process occurs the first time a new CONVERGE/CONVERGE Pro model is connected to the system, and once when you switch to a different USB port on the system. If you install drivers for a model and subsequently connect another model to the system via USB, Windows will repeat the installation process for the new device type.

12. When the **Found New Hardware Wizard** appears, select the **No, not this time** radio button. Click **Next** to begin installation.



13. Select the **Install the software automatically** radio button in the second screen of the wizard (shown below), then click **Next** to proceed with installation.



14. When the Windows unsigned driver warning dialog appears, proceed to install the drivers.
15. When the USB driver installation is complete, click **Finish** to close the wizard.
16. If you will be using IP to run Console, connect Ethernet cables between your LAN and CONVERGE/CONVERGE Pro device(s).

The Console software and your CONVERGE/CONVERGE Pro device(s) are now ready for use. If you experience any problems during installation, contact ClearOne technical support.

CONVERGE CONSOLE OVERVIEW

The **CONVERGE Console** software provides a powerful, intuitive interface for configuring and controlling your CONVERGE/CONVERGE Pro system. While you can use LCD Programming for simple configuration tasks, you must use Console to configure the advanced settings required to customize units for your application.

Accessing CONVERGE Console

Start CONVERGE Console by double-clicking the  desktop icon, or by clicking the **Start** button in Windows and selecting **All Programs > ClearOne Communications > Converge Console > Converge Console** from the program list.

After Console loads, you can open an existing **Site File** from the **File** menu, or create a new site file by selecting **New Site**. When a site file is opened, Console displays the **Unit Tab** as shown below.

Default User ID and Password

Connecting to a site with Console requires a user name and password. The default user name is **clearone**; the default password is **converge**.

NOTE: User names and passwords are not case sensitive. ClearOne recommends that you record user names and passwords and store them in a secure place. **There is no way to retrieve passwords.** If you forget a password, the only way to connect to the device is to Default the unit.

After connecting, you can add/modify user ID's, change passwords, and set access privileges using the Site Properties dialog.

Navigating CONVERGE Console

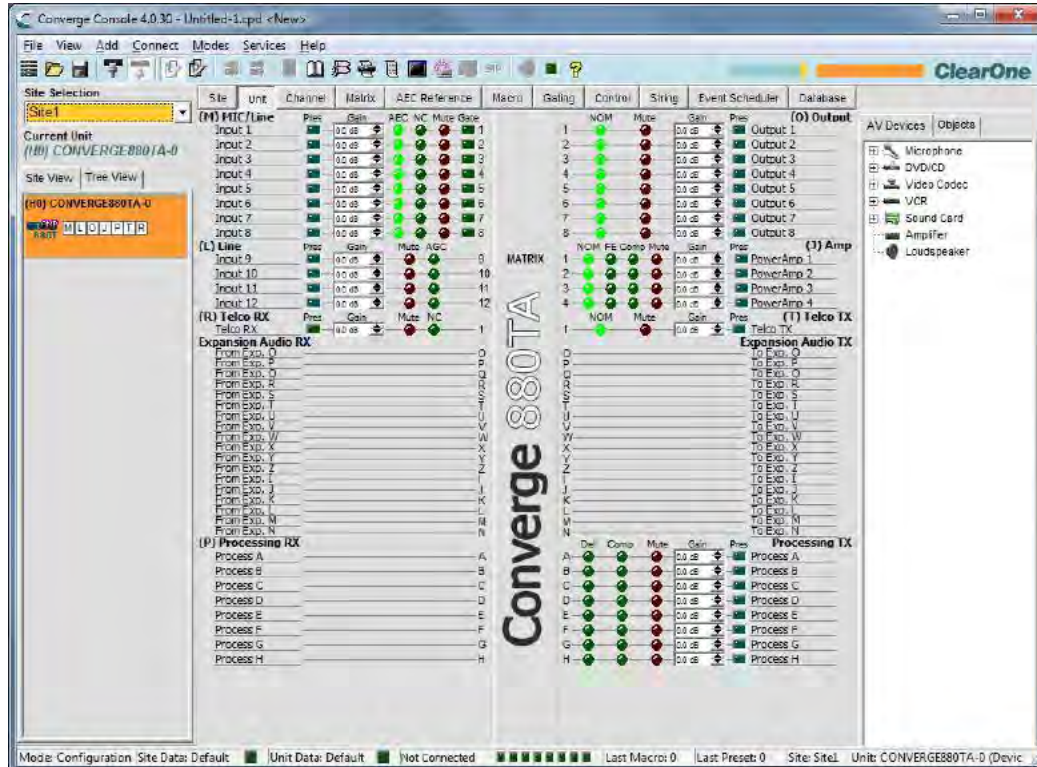

The Console window consists of the components described in the following sections.

Menu Bar

File View Add Connect Modes Services Help





















Menus available on the Menu Bar include:

- **File**
- **View**
- **Add**
- **Connect**
- **Modes**
- **Services**
- **Help**: Opens the context-sensitive help system; provides software and firmware version information.

Button Bar



Controls on the Button Bar include:

-  **Create Site**
-  **Open Site**
-  **Save Site**
-  **Connect**
-  **Disconnect**
-  **Configuration Mode**
-  **Preset Mode**
-  **Execute Preset**
-  **Run Macro**
-  **Dialer**
-  **Phonebook**
-  **Label Editor**
-  **Device Log**
-  **Event Log**
-  **Debug Console**
-  **Web Builder**
-  **Firmware Loader**
-  **VH20 Unit Properties**: (This button is only active when Console is connected to a VH20)
-  **Safety Mute**: Toggles Safety Mute on and off. Safety Mute holds all outputs in a muted state.
-  **Signal Generator LED**: Flashes green when the signal generator for any unit in the site is turned on.
-  **Help**: Opens the context-sensitive help system; provides software and firmware version information.

Tab Bar

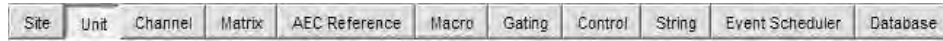

Tabs available on the Tab Bar include:

- **Site**
- **Unit**
- **Channel**
- **Matrix**
- **AEC Reference (PA Adapt Reference for SR 1212/SR 1212A)**
- **Macro**
- **Gating**
- **Control**
- **String**
- **Event Scheduler**
- **Database**

Clicking a tab displays the screen for that tab in the Console Center Pane.

Site Pane

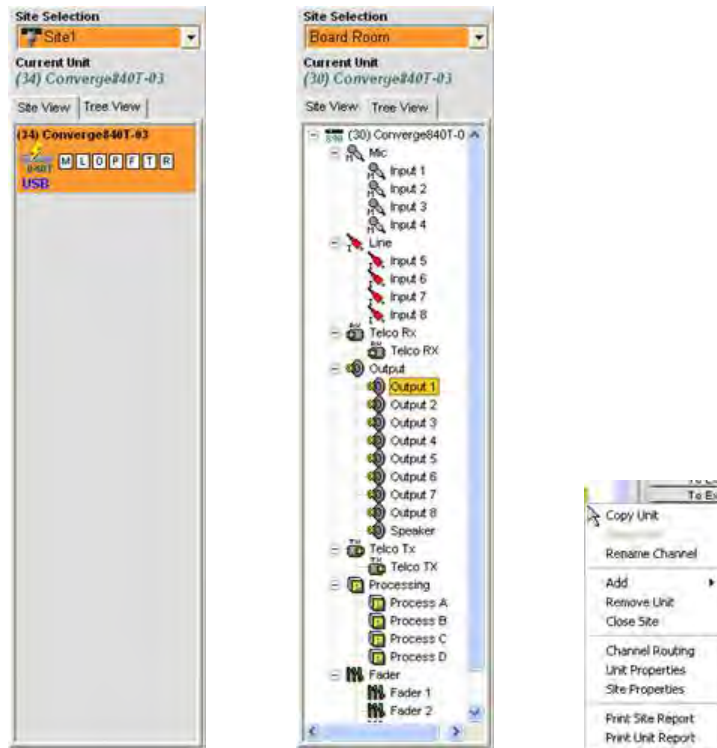

In Configuration Mode, the Site Pane contains the Site Selection drop-down list, Site View tab, and Tree View tab. Right-clicking in either the Site View tab or the Tree View tab brings up a context menu with site, unit, channel, and reporting options applicable to the selected unit type.



In Preset Mode, the Site Pane displays the Current Site, Current Unit, Preset Selection list, and the Preset Name, Description, and Preset Mask entry fields.

Center Pane

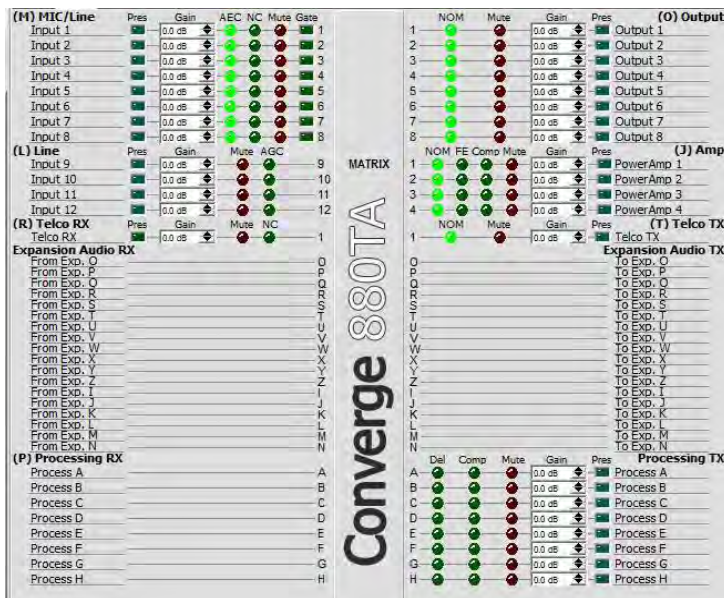

The Center Pane displays the screen for the selected Console Tab. As shown above, the default screen is Unit Tab.

Objects Pane

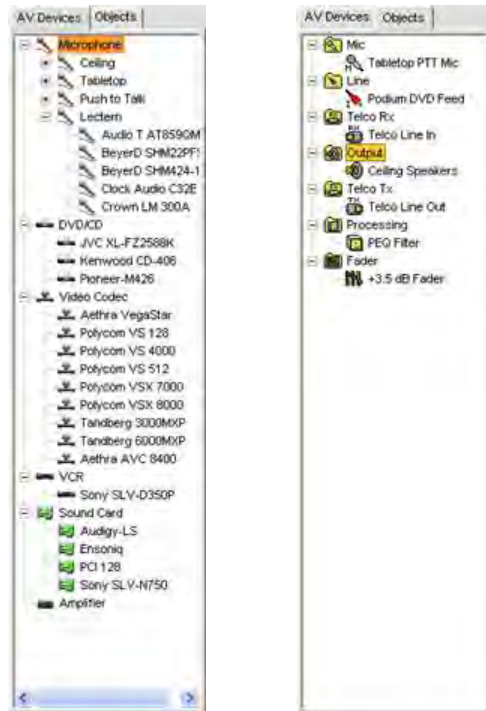

The Object Pane contains the AV Devices tab, which allows you to select from a list of pre-configured device settings and apply them instantly to a channel; and the Objects tab, which allows you to select from a list of custom channel objects and instantly apply them to a specific channel type. AV Devices and channel Objects are stored in the Database.

Status Bar



The Status Bar displays the current Console Mode, as well as connection status, site information, and unit information.

The LEDs in the Status Bar indicate current status as follows:

- **Clear** (no LEDs illuminated): Not connected
- **Yellow**: Connecting/pending
- **Green**: Connected
- **Red**: Off-line
- **Purple**: Current with error

Console Modes

Console has two modes: Configuration Mode and Preset Mode. Configuration Mode allows you to configure a wide range of advanced settings for your unit(s). Preset Mode allows you to create presets for specific venues and apply them instantly to CONVERGE/CONVERGE Pro unit(s).

For additional information, refer to the *Table of Contents* for these related topics:

- **LCD Programming**
- **Site Properties**
- **Configuration Mode Overview**
- **Preset Mode Overview**

SITE FILE OVERVIEW

Site Files allow you to store configuration settings for one or more units for a specific application or venue. Site files also provide Console with the necessary information to communicate with the CONVERGE/CONVERGE Pro devices using your PC.

Site files are a powerful tool for creating a library of configuration files for specific applications and room types. For example, you can create a baseline site file for divided rooms that specifies mic gating, output crosspoints, AEC, and AGC/ALC, store it on your hard drive, and use the file for other similar installations. This approach allows you to standardize settings across venues.

NOTE: All units ship with a default site configuration file.

Site files also enable you to create users, set passwords, set unit master/slave control status, set up email notification, and configure time/local parameters as described in the Site Properties topic.

Accessing Site Files

To open a Site file, select the **File** menu in **Console**.

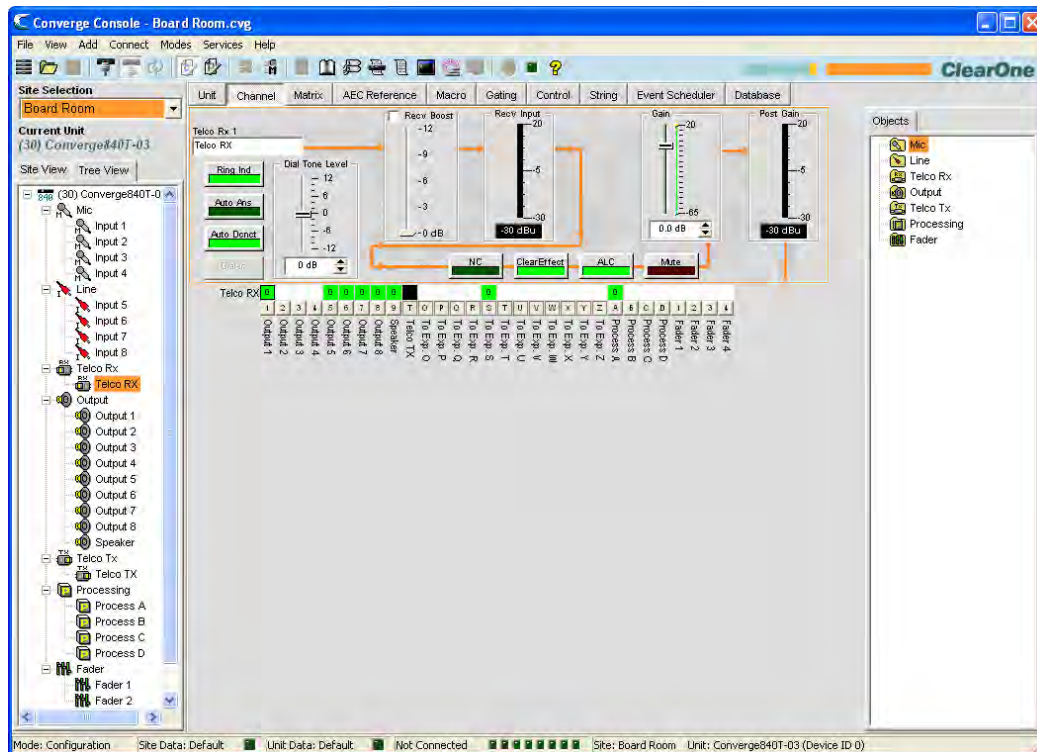

The **File** menu appears. Select **Open Site** as shown below.



The **Open** dialog appears as shown below.



Locate the site file you want to open and click **Open**. Console opens the site file, and it appears in the **Site Selection** drop-down list in the **Site Pane** as shown below. Use the **Files of type** drop-down list to open G-ware files (.PSR file extension), original CONVERGE files (.cvg file extension), or CONVERGE ver 3 files (.cnv file extension) and convert them to CONVERGE Pro (.cpd file extension) site files.



The selected site file is now available for use. You can open up to four site files simultaneously and switch between them using the **Site Selection** drop-down list.

Saving Site Files

To save the current Site configuration parameters, including any changes made since the active Site file was opened, click the **Save** button  on the Button Bar, or select **Save or Save As** from the **File** menu.

For additional information, refer to the *Table of Contents* for these related topics:

- **Create A Site**
- **Connect to a Site**
- **Site Properties**
- **Console Overview**
- **Configuration Mode Overview**
- **Channel Tab Overview**
- **Matrix Tab**

CONNECT TO A SITE

Connect To a Site

Click the **Connect** button  on the Console **Button Bar**, or select **Connect** from the **Connect Menu**. The **Connect** dialog appears as shown below.



Connection options include:

- To automatically create a new site file, select the **Create New Document and Connect to Site** radio button
- To pull data from the unit to the current Site File, select the **Pull Data from Unit to Current Document** radio button (only available if a site file is open)
- To push data from the current site file to the unit, select the **Connect to Site and Push Document** radio button (only available if a site file is open the unit is added)
- To connect via USB, select the **USB Connection** radio button
- To connect via IP, select the **IP Connection** radio button, and select a unit from the **Available Addresses** drop-down list (or enter an IP address in the **Enter Address** entry box)

Press the **Connect** button to connect to the site or **Cancel** to close the dialog.

NOTE: The default login user name is **ClearOne**. The default password is **CONVERGE**. User names and passwords are not case sensitive.

Disconnect from a Site

To disconnect from a site, press the **Disconnect** button  on the Console **Button Bar**, or select **Disconnect** from the **Connect** menu. Answer **Yes** to the **Confirm** dialog that appears, or **No** to cancel.

For additional information, refer to the *Table of Contents* for these related topics:

- **Site File Overview**
- **Site Properties**
- **Unit Communication (IP) Settings**

SITE PROPERTIES

Site Files are created and modified using the Site Properties window in Console. Site files contain all information about a particular installation including properties for all units in a site. For more information, see the Site File Overview topic.

Accessing Site Properties

To access the Site Properties window, select the **File** menu in **Console**, or right-click anywhere in the **Site View** or **Tree View** panes and select **Site Properties** from the shortcut menu.

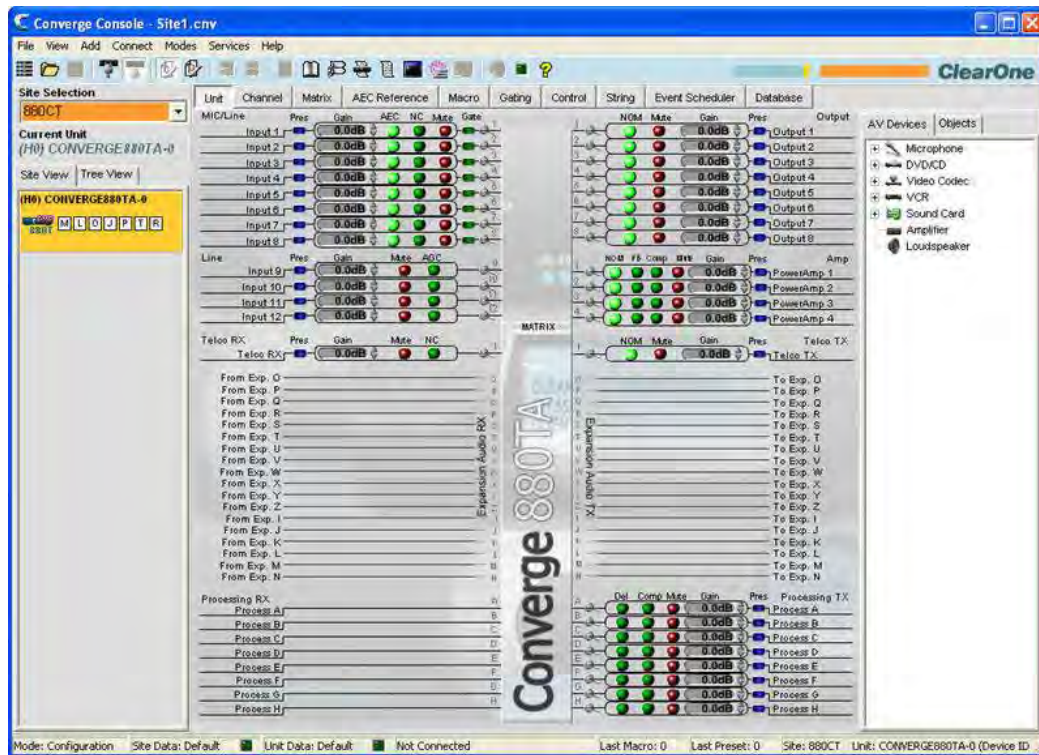

The **File** menu appears. Select **Site Properties** as shown below.



The **Site Properties** window appears with the **General tab** selected.

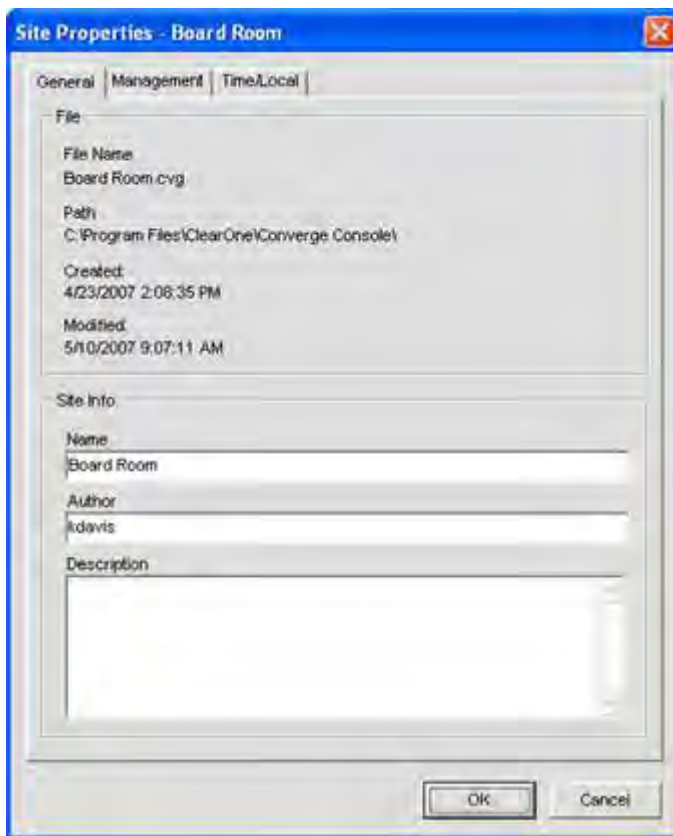

Create A New Site

To create a new site, select **New Site** from the **File** menu or by clicking the **New Site** button  on the **Console Button Bar**. The **Site Properties** window appears.

NOTE: You must have administrator privileges to connect to units with Console, and to modify user names and passwords. User names and passwords are not case sensitive.

Site Properties are described in the following sections.

Site Properties: General Tab

The **General** tab of the Site Properties window displays Site file information as shown above. Enter a site name, file author, and site description in the **Site Info** section of the tab. Press **OK** to save the changes, **Cancel** to close the Site Properties window, or click on the **Management** or **Time/Local** tabs to continue site configuration.

Site Properties: Management Tab

The **Management** tab (shown below) enables you to configure SNMP parameters, email notification settings, as well as user names and passwords.

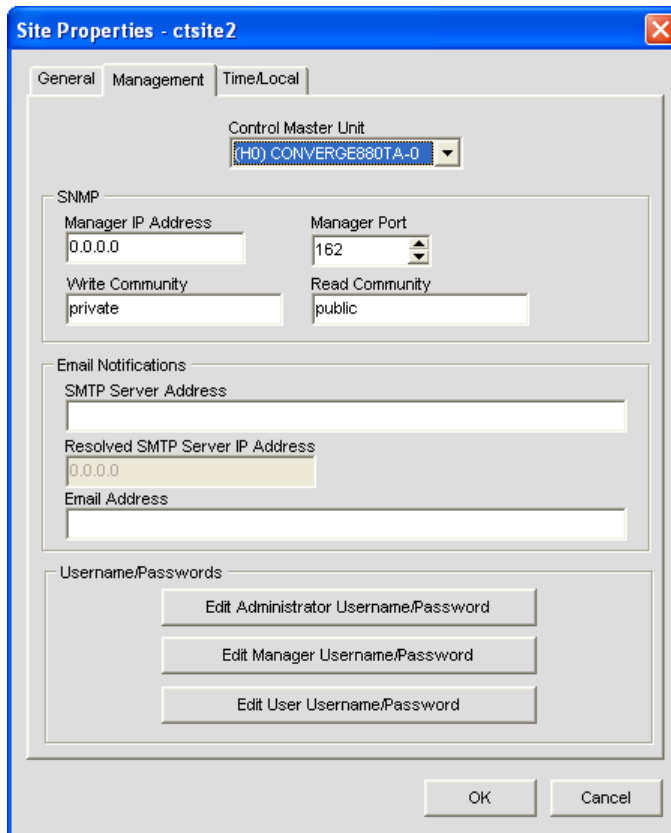

The screenshot shows the 'Site Properties - ctsite2' dialog box with the 'Management' tab selected. The 'Control Master Unit' dropdown menu is set to '(H0) CONVERGE880TA-0'. The 'SNMP' section contains fields for 'Manager IP Address' (0.0.0.0), 'Manager Port' (162), 'Write Community' (private), and 'Read Community' (public). The 'Email Notifications' section has fields for 'SMTP Server Address', 'Resolved SMTP Server IP Address' (0.0.0.0), and 'Email Address'. The 'Username/Passwords' section has three buttons: 'Edit Administrator Username/Password', 'Edit Manager Username/Password', and 'Edit User Username/Password'. 'OK' and 'Cancel' buttons are at the bottom.

Control Master Unit

All units in the site appear in the Control Master unit list. Selecting a Control Master unit designates that unit to control the SNMP interactions for the entire site across IP-based networks. To use SNMP, the Control Master unit(s) must be connected to the LAN via IP.

All other units in the site are Control Slave units. Control Slave units report events to the Control Master Unit for SNMP reporting and SMTP email notifications.

Serial Control interactions and Audio Control interactions are not affected by a unit's Control Master designation.

NOTE: All units are Control Slave units by default.

SNMP

In the **SNMP** section, enter the SNMP settings for the site. The Control Master unit uses this information to communicate SNMP events, including events reported by Control Slave units.

NOTE: The Installation & Documentation CD contains SNMP MIB files for each device type for use with third-party SNMP management software.

Email Notifications

In the **Email Notifications** section, enter the SMTP Server address in the **SMTP Server Address** field and the IP address of the server that will receive email notifications in the **SMTP Server IP Address** field. The recipient's email address in the **Email Address** field.

User name/Passwords

In the **User name/Passwords** section, click the button for the user type that you want to create. The **Name/Password** dialog appears as shown below.



NOTE: The default user name is **clearone**. The default password is **converge**. User names and passwords are not case sensitive.

User access privilege levels are as follows:

- **Administrator:** Full Console and web portal access.
- **Manager:** Web access to Dialer, Maintenance, Registration, About, and Help pages.
- **User:** Web access to the Dialer, Registration, About, and Help pages.

Enter the appropriate user information and press **OK** to save the user information, or **Cancel** to return to the **Site Properties** dialog.

Site Properties: Time/Local Tab

The **Time/Local** tab enables you to configure time settings and specify location information as shown below. As shown below, you can set the date and time manually, synchronize the time with a PC, or use network time servers.

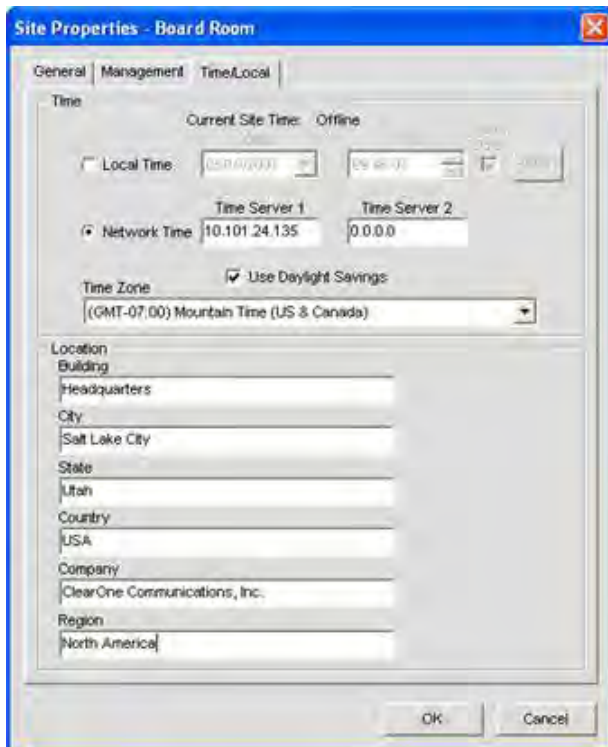

In the **Time** section of the tab, select **Local Time** or **Network Time** for the clock synchronization source.

When **Local Time** is selected, the **Apply** button is activated; pressing it updates the date and time on all units in the current site.

When **Network Time** is selected, you must enter the IP address(es) for the time synchronization server(s). The date and time is updated for all units in the site when you press the **OK** button, and it is automatically synchronized with the specified server(s).

Enter location information in the **Location** section of the tab (optional). Press **OK** to save the site file, or **Cancel** to close the **Site Properties** window.

For additional information, refer to the *Table of Contents* for these related topics:

- **Site File Overview**
- **Connect To A Site**
- **Unit Properties**
- **Configuration Mode Overview**

UNIT PROPERTIES

Unit Properties define properties for a specific CONVERGE/CONVERGE Pro unit. Unit Properties enable you to configure general unit settings such as name, and telephone country code, as well as IP and serial communication settings. Properties that apply to all units in a site are configured using Site Properties.

Accessing Unit Properties

To access the **Unit Properties** window, right click the unit you want to configure in either the **Site View** tab or the **Tree View** tab of the **Site Pane** in **Console**.

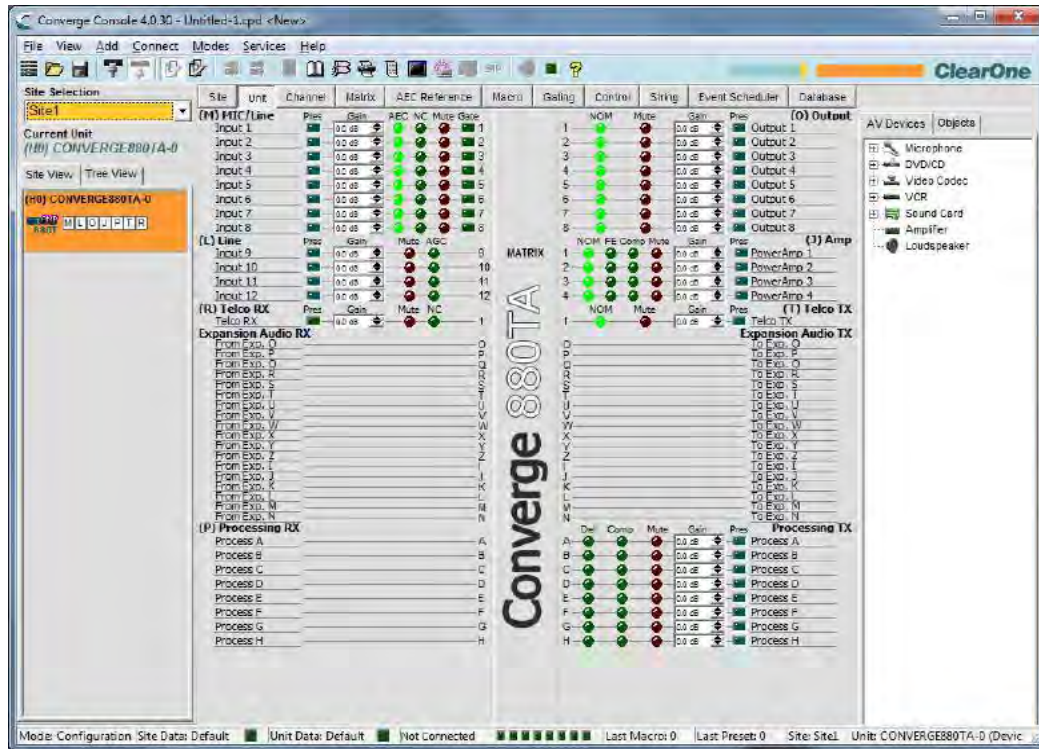

The **Site/Unit** menu appears. Select **Unit Properties** as shown below.

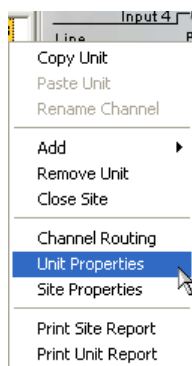

The **Unit Properties** window appears as shown below.



Add A New Unit

To add a unit to a Site, right-click in either the **Site View** tab or the **Tree View** tab of the **Site View** pane, or select the unit type you want to add from the **Add** menu on the Menu Bar as shown below.

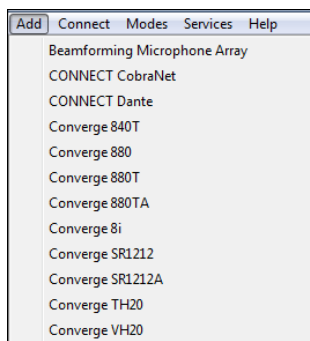

The **Unit Properties** window appears. Unit Properties settings are described in the following sections.

Unit Properties: General Tab

The **Unit ID** and **MAC Address** for the selected unit are automatically displayed at the top of the **Info** section of the tab. When connected, the firmware version, dictionary version, and DSP date versions are displayed in the **Versions** section at the bottom of the tab (when connected). These settings cannot be modified.

Device Name

Enter a descriptive name in the **Device Name** field. Device names are used as network identifier on NetBIOS networks. They must start with a letter and can contain both letters and numbers, with a maximum length of 15 characters. No special characters are allowed except for “-”.

Device ID

Select a Device ID from the **Device ID** drop-down list.

Device IDs ensure that Console synchronizes with the proper unit when there are multiple units of the same type in a site. Therefore, each unit of the same type in a site must have a unique Device ID assigned using the front panel LCD Settings menu. All units ship from the factory with a default DID of 0.

Device Types and Device IDs by model are as follows:

Model	Device Type	Device ID
880	1	0-B
TH20	2	0-F
VH20	E	0-F
840T	3	0-B
8i	A	0-B
880T	D	0-B
880TA	H	0-B
SR 1212	G	0-B
SR 1212A	I	0-B
Beamformer	N	0-F
CONNECT CobraNet/Dante		0-7

For example, if there are two CONVERGE Pro 880s and one 840T in a site, the 880s must have unique DID's. They could be assigned DID's of 0 and 1 respectively, while the 840T could be assigned a DID of 0 without any conflicts.

NOTE: You must disconnect from the site in order to set the Device ID. Press the **Disconnect**  button on the **Button Bar**.

NOTE: The DID specified in Console **MUST** match the DID set for that unit in the LCD Settings Menu. Otherwise when you reconnect to the site, Console will correctly recognize the unit with the correct DID, but it also adds a duplicate unit with the incorrect DID.

Audio Master

Select **Slave** (default) or **Master** from the **Audio Master** drop down list. Audio Master units ignore audio from upstream units in a site as shown in the sample stack below.

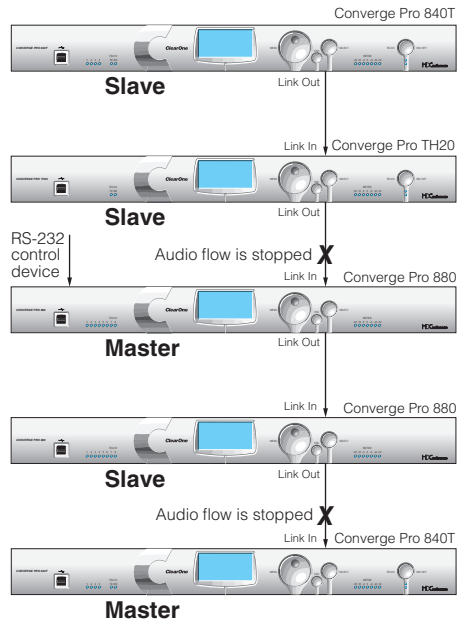

This prevents audio from being received from units above the master unit in a site. For example, you can configure a site with multiple units for a room-combining application where all units act together when three smaller rooms are combined into a larger room. When the rooms are divided again, the audio from one room will not be available in the other two rooms due to the Audio Master configuration.

In graphic above, the third unit in the network is an Audio Master with an RS-232 control device attached. Audio from the first and second units in the network does not pass beyond the second unit. Likewise the second Audio Master unit in the network does not pass audio from the unit before it. Sites can use multiple RS-232 devices, which you can connect to any unit regardless of Control Slave or Master designations.

Serial control is not affected by Audio Master or Slave designations. Global serial control of the site is maintained by the unit connected to a control device through its RS-232 port, in this case the third unit in the stack, which is also designated as the first Audio Master in the network.

NOTE: A master unit is not required for CONVERGE/CONVERGE Pro sites, and in most installations, all units will be slaves. Also, SNMP Control is not affected by Audio Master designations.

For information about the Link In and Link Out connections used to build sites, see *Controls & Connections*.

Room

Enter a descriptive name for the room in the **Room** field.

Default Meter & Channel

Select an input, output, or processing channel to be the **Default Meter** on the front panel LED Meter when a channel is not specifically selected.

Front Panel Mode & PIN (Front Panel Lock/Unlock)

Select **Lock** in the **Front Panel Mode** field to lock the front panel LCD of the unit and require a PIN code to unlock it. Enter the unlock code in the **Front Panel Pin** field. Select **Unlock** in the **Front Panel Mode** field to leave the front panel LCD unlocked.

Telephone Country Code

Select the appropriate Telephone **Country Code** for your installation (880TA, 880T, 840T, TH20 models only).

Unit Properties: Comm (Communications) Tab

The Comm tab contains IP protocol selection and address settings, as well as serial port configuration settings as shown below.

The screenshot shows a software window titled "Convergence BBOTA Unit Properties - Device ID 0". It has two tabs: "General" and "Comm". The "Comm" tab is active. Under "IP Settings", the "Use DHCP" checkbox is checked. Below it are input fields for "IP Address", "Subnet", and "Gateway", all containing "0.0.0.0". There is also an unchecked checkbox for "Use DNS" with a "DNS Address" field containing "0.0.0.0". The "IP Filters" section contains four fields labeled "Filter 1" through "Filter 4", each containing "0.0.0.0". The "Serial Port Settings" section has a "Baud Rate" dropdown set to "57600", a "Serial Echo" dropdown set to "On", a "Flow Control" dropdown set to "Hardware", and an unchecked checkbox for "AMX Duet Discovery".

IP Settings

If you want to use DHCP (Dynamic Host Configuration Protocol), select the **DHCP** checkbox. (Selecting DHCP disables the remaining IP settings.) Otherwise, enter the **IP Address**, **Subnet**, and **Gateway** information, and **DNS** (Domain Name Server) addresses for your installation. The default is Use DHCP.

IP Filters

Use IP Filters to enter specific IP addresses that will be allowed to connect to the selected unit. You can specify a range of IP addresses by using zeros. For example, entering 192.168.105.0 will allow any IP addresses in the 192.168.105.1 to 192.168.105.254 range to access the unit.

Serial Port Settings

Select the **Serial Port** settings (**Baud Rate** and **Flow Control**) that are appropriate for your installation. **Serial Echo** enables and disables echo on the serial port. The default for Baud Rate is 57600. The default for Flow Control is Hardware. The default for Serial Echo is On.

When you are finished configuring unit properties, click **OK** to save the changes, or **Cancel** to close the **Unit Properties** window.

AMX Duet Mode

Sets a beacon to signify the device is AMX compatible and looks for new or updated modules on the AMX Web Site. If new or updated modules are available, the user will be prompted to download the module.

CONVERGE PRO VH20 UNIT PROPERTIES

Unit Properties for the CONVERGE Pro VH20 are accessed identically to any other CONVERGE unit. However, once the Properties, **SIP Properties** window has launched, several new configuration features are available.

NOTE: The **SIP Properties** window is also accessible by right-clicking the VH20 icon under **Site View** and selecting **SIP Properties**.

The screenshot shows the 'Converge VH20 Unit Properties - <New Unit>' dialog box with the 'SIP' tab selected. The 'SIP' tab is further divided into sub-tabs: 'Proxy', 'Timers', 'Network', 'Audio Stream', and 'Dial Plan'. The 'Proxy' sub-tab is active, showing the following configuration:

- Phone Number:** Local Phone Number: [Empty], Display Name (Hostname): CONVERGEVH20-0
- Proxy 1:** SIP Authentication: Authorization User: admin, Authorization Password: clearone
- Proxy 2:** SIP Proxy Registration: User Domain: Default, Proxy IP Address/URL: [Empty], Proxy Port: 5060
- Outbound Proxy:** Proxy IP Address/URL: [Empty], Proxy Port: 5060
- SIP Transport:** UDP Listen Port: 5060 (selected), TCP Listen Port: 5060, TLS Listen Port: 5061. CA Certs: Private Key: [Empty], Local Cert: [Empty]. Buttons: Add..., Del, Export Certificates...

At the bottom, there are two status indicators: 'SIP Proxy 1 Registration: Disabled' and 'SIP Proxy 2 Registration: Disabled'. The 'OK' and 'Cancel' buttons are at the bottom right.

Five tabs contain most of the configuration settings required to customize the CONVERGE Pro VH20. **Do not** modify these settings unless you have in-depth knowledge of VoIP, SIP and Network functions, setup and protocols. Also, be sure you have sufficient network privileges and access required to make required changes to your network during setup. If you are unsure, contact your Network Administrator before proceeding.

Proxy

The Proxy tab consists of 6 sections.

Phone Number

- Displays the local phone number assigned to the specific unit. This number is usually obtained through your Network Administration.
- Display Name (Hostname): The name assigned to the specific unit. This name is configured within the CONVERGE Console software.

Proxy 1, Proxy 2: Proxy 1 and Proxy 2 are identical and used as redundancy items.

- **SIP Authentication:** Enables SIP Authentication from the Network
 - **Authorization User:** User name assigned for network authorization
 - **Authorization Password:** Password assigned for network authorization
- **SIP Proxy Registration**
 - **User Domain**
 - **Default**
 - **Proxy**
 - **Domain Name**
 - **Proxy IP Address/URL:** Enter the IP address/URL of the proxy server
 - **Proxy Port:** Enter the port number for the proxy server
- **Outbound Proxy:** Enable this feature to use a proxy outside or alongside a firewall.
 - **Proxy IP Address/URL:** Enter the IP address/URL of the proxy server
 - **Proxy Port:** Enter the port number for the proxy server
- **SIP Transport:** Set transport settings here.
 - **UPD Listen Port:** Specify the UPD Listen Port.
 - **TCP Listen Port:** Specify the TCP Listen Port.
 - **TLS Listen Port:** Primarily used by Avaya systems, the TLS Listen Port is specified here.
 - **Private Key:** Click the **Browse** button to upload your Private Key file
 - **Local Cert:** Click the **Browse** button to upload your Local Certificate file
 - **CA Certs:** Use the **Add** or **Del** buttons to add or remove CA Certs

Timers

Timers are used to keep SIP sessions “alive” on the network. Normally, default values are appropriate. Occasionally your Network Administrator may want to customize the settings. Do not change these settings unless directed to do so.

All Values are in milliseconds unless otherwise noted.

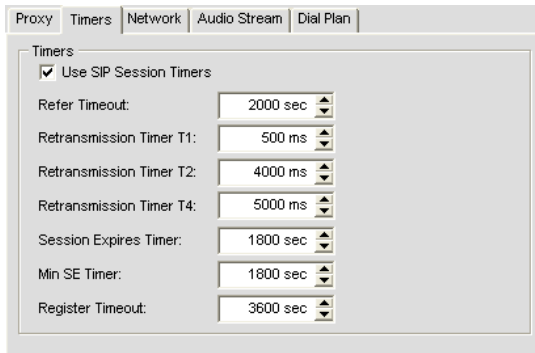

- **Use SIP Session Times:** This box is checked by default. Removing the check will disable all timers.
- **Refer Timeout:** Number of ms the server waits for a reply
- **Retransmission Timers:** Refers to three Timers
 - **T1:** Sets the round-trip time for a packet
 - **T2:** Sets the retransmit time from a non-invite request (REFER, BYE, etc.) and INVITE responses
 - **T4:** Sets the total time a given message can be on the network
- **Session Expires Timer** (Value is listed in Seconds): Default time before the current session expires due to inactivity. This value **MUST** be greater than the **Min SE Timer** value.
- **Min SE Timer** (Value is listed in Seconds): Minimum Session Timer
- **Register Timeout** (Value is listed in Seconds): The period of time a given device is registered on the network.

Network

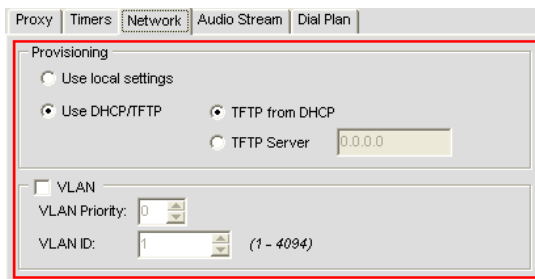

The Network tab allows the user to set basic network settings. Have your Network Administrator modify these settings.

- **Provisioning:** Provides the VH20 with access to data and network resources by receiving authorization and privileges via resource management.
 - **Use local settings:** The unit uses local settings provided by the server
 - **Use DHCP/TFTP:** User provides settings for the VH20 to gain access to the network
 - **TFTP from DHCP:** TFTP settings are received from the server.
 - **TFTP Server:** User manually enters the IP address of the TFTP Server.
- **VLAN:** Virtual LAN - A LAN configured through software rather than hardware. Toggling this setting activates the flexibility a VLAN can provide SIP configurations.
 - **VLAN Priority:** Establishes the priority of the ID data coming from this specific unit.
 - **VLAN ID:** Provides the ID number to the specific unit

Audio Stream

The Audio Stream tab contains user configurable settings for the audio stream, encryption, QoS and Codec details. Do not change these settings unless you have detailed knowledge of their purpose, they could dramatically effect call quality and performance.

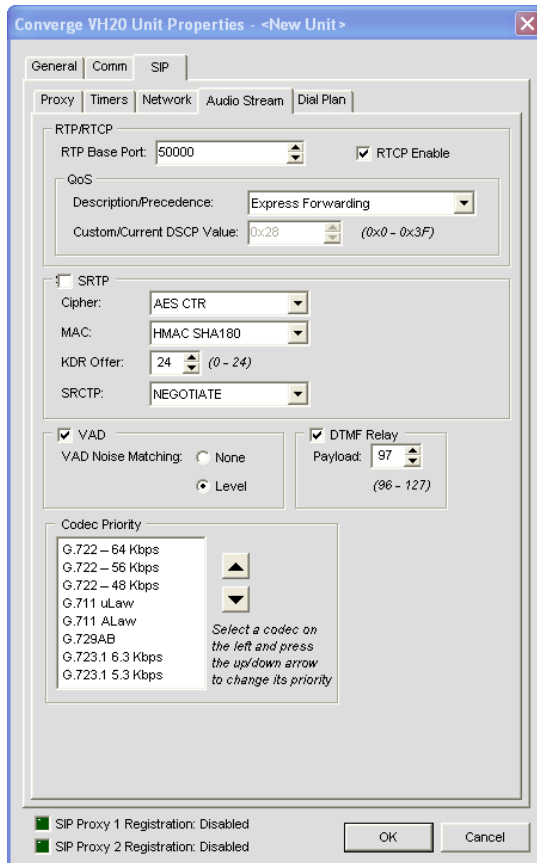

• RTP/RTCP

- **RTP Base Port:** Port set to transmit RTP data.
- **RTCP Enable:** Check this box to enable RTCP
- **QOS** (Quality of Service): QOS is a method in which certain high demand (VoIP, Video, etc.) applications are allowed to maintain a minimum standard of service across a network to avoid unacceptable delays, dropouts or service interruptions during their communications by determining which packets have priority over others.

- Description/Precedence: This drop-down consists of several options.

- **Express Forwarding:** Default
- **Best Effort**
- **Class 1**
- **Class 2**
- **Class 3**
- **Class 4**
- **Control 6**
- **Control 7**

- **Custom:** Selecting this option enables **Custom/Current DSCP Value**. Adjust values to fit QOS needs.

- **SRTP:** Enabling this setting activates encryption on the VH20

- **Cipher:** This drop-down selects the cipher to be used.
 - **Null:**
 - **AES CTR:**
 - **AES F8:**

- **MAC:**
 - **Null**
 - **HMAC SHA180**
 - **HMAC SHA132**
- **KDR Offer:** 0-24
- **SRCTP:**
 - **Negotiate**
 - **Enable**
 - **Disable**
- **VAD:** Enables “comfort noise” which simulates background noise found in analog phone lines.
 - **VAD Noise Matching:** Settings are **None** or **Level**. Default is Level.
- **DTFM Relay:** This setting emulates normal key tones on a regular phone when used during a call (for example, to select options from an in-call menu).
 - **Payload:**
- **Codec Priority:** Negotiates the best possible codec for each call that both sides can utilize; both units must have a given codec in order to use it. If the codec is not present, the next one in the list is tried. This process is repeated until the best match is found. To use the **Priority** setting, follow the instructions given in the tab.

Dial Plan

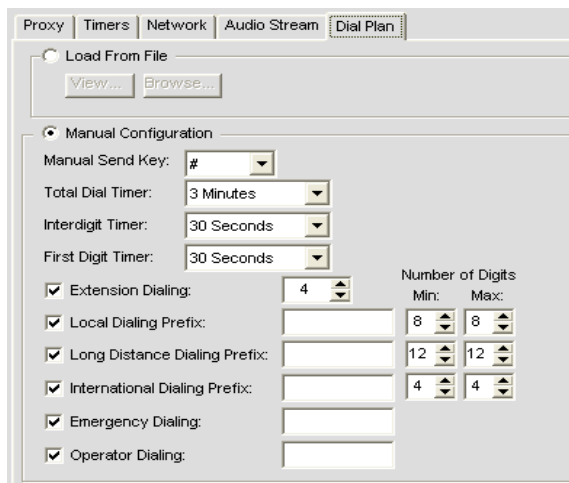

Dial Plan: The Dial Plan consists of numbers and pattern digits for any given telephone number. Since businesses deal in World-wide calling, this should consist of country codes, access codes, area codes and any combination of digits that can be dialed. To accommodate this, Dial Plans are required.

- **Load from File**
- **Manual Configuration**

Note: After any changes are made, CLICK **OK** to save all changes!

BEAMFORMING MICROPHONE ARRAY UNIT PROPERTIES

Unit Properties for the Beamforming Microphone Array are accessed identically to any other CONVERGE unit. When you open the unit properties screen on the Beamforming Microphone Array, there is a Beamforming tab. When the Unit Properties is opened and the Beamforming tab is selected, there are several different configuration features available.

- Select the CONVERGE Pro Unit which contains the macro for muting.
- Select the Macro to turn on the mute.
- Select the Macro to turn off the mute.

Note: If no macro is selected, all connected Beamforming Microphone Arrays will toggle the mute when a Beamforming Microphone Array mute button is pressed.

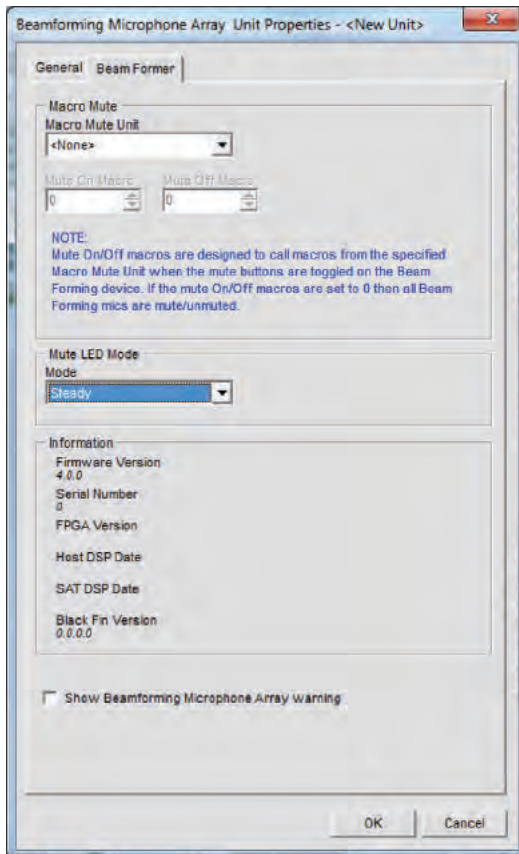

- Set the **Mute Mode** LED to **Off** to turn off the LED's on the Beamforming Microphone Array.
- Set the **Mute Mode** LED to **Steady** to turn the Beamforming Microphone Array's LED to solid blue when not muted and solid red when muted.
- Set the **Mute Mode** LED to **Blinking** to turn the Beamforming Microphone Array's LED to solid blue when not muted and blinking red when muted.
- Select the Show Beamforming Microphone Array warning to show a warning when a Beamforming Microphone Array is added.

For additional information, refer to the *Table of Contents* for these related topics:

- **LCD Programming Overview**
- **LCD Settings Menu**
- **Site File Overview**
- **Site Properties**
- **Connect To A Site**
- **Preset Mode Overview**
- **Controls & Connections**
- **Serial Control**
- **SNMP Control**

CONNECT COBRANET UNIT PROPERTIES

The next two figures show the **Unit Properties** tabs for the CONNECT CobraNet bridge.

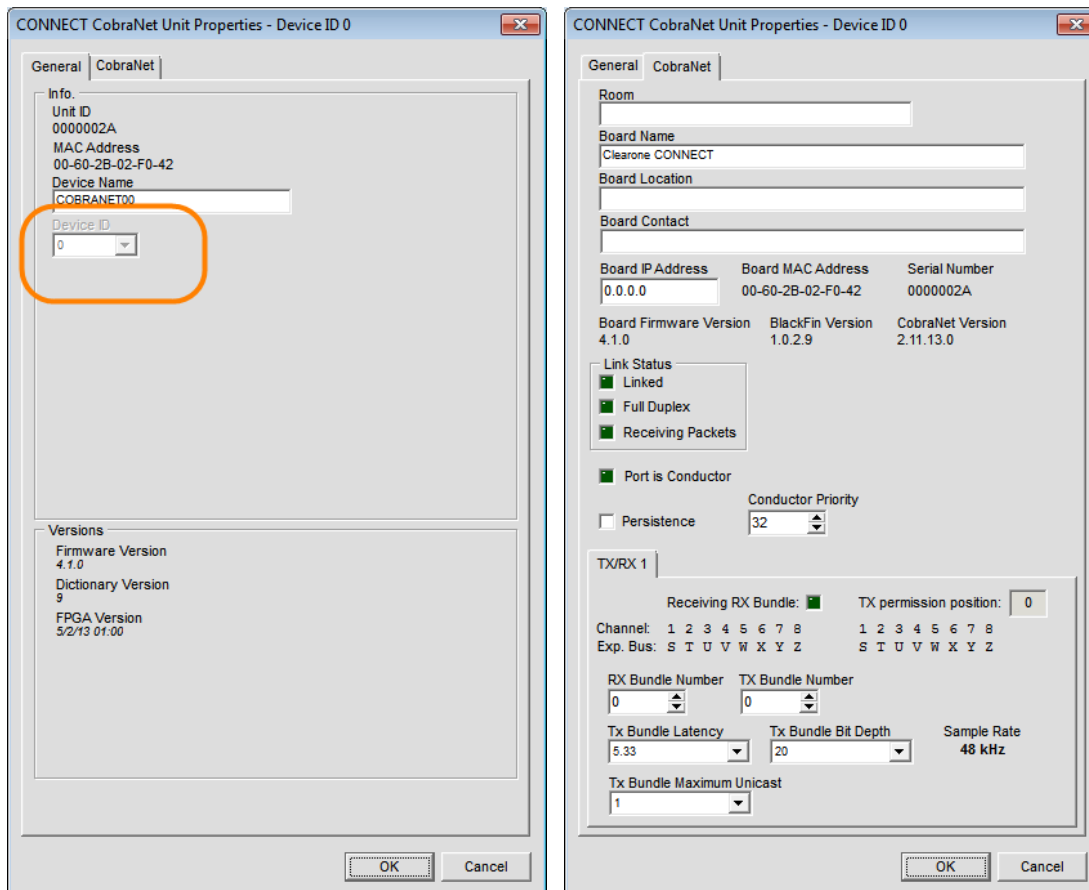

On the **General** tab, set the **Device ID** (DID) to match that of the rotary selection switch of the CONNECT CobraNet device.

The **CobraNet** tab is used to perform basic configuration setup of the CobraNet endpoint. These settings can also be configured via third-party control software.

Room is the same Room Location information available in **Unit Properties** on all CONVERGE Pro Products.

Board Name, **Board Location**, and **Board Contact** are specific to CobraNet.

The default **Board IP Address** for CobraNet hardware is 0.0.0.0 and can be configured manually or automatically via third party control software. The **Board MAC Address** and version information are also displayed here.

The **Link Status** indicators display the physical state of the CobraNet RJ-45 connection on the hardware.

Persistence allows a way for CobraNet devices to either default or retain its settings on a power cycle. This setting is redundant on a CONVERGE Pro system but is compatible with third-party CobraNet systems.

Conductor Priority ranges from 0 – 255 and the default Priority is 32. Set **Conductor Priority** to less than 32 to ensure device never becomes the Conductor. Set **Conductor Priority** greater than 32 to increase chance of being the Conductor.

RX Bundle Number

Rx Bundle Number sets the Bundle number that CobraNet receives from a CobraNet Transmitter. When set to 0 the receiver is off. Bundle Numbers 1 through 255 receive a Multicast stream. Bundles 256 through 65279 are for Unicast. Finally, Bundles 65280 through 65355 are private bundle numbers and reserved for Cirrus Logic devices. ClearOne CobraNet is not able to use the Private Bundles.

TX Bundle Number

Tx Bundle Number sets the type of transmitting bundle based on the Bundle Number. Bundle Numbers 1 through 255 will transmit a Multicast stream. Bundle Numbers 256 through 65279 are for Unicast and typical values start at 1000.

Bundle Latency describes the buffering and transmission of audio data. This typically incurs a delay of 256 samples or 5 1/3 milliseconds. This delay can be reduced by sending smaller packets more often, but comes at the cost of higher processing demands and greater network demands.

CONNECT DANTE UNIT PROPERTIES

The next two figures show the **Unit Properties** tabs for the CONNECT Dante™ network bridge.

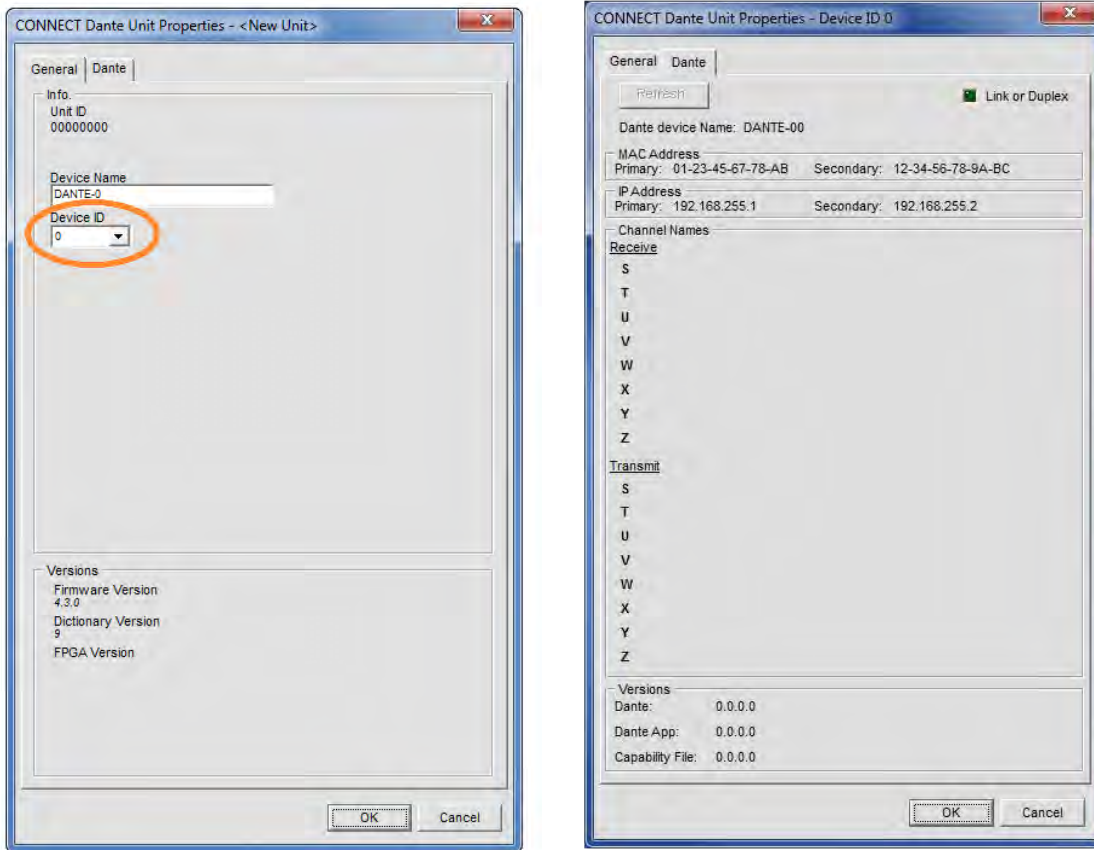

Under the **General** Tab, set the **Device ID** (DID) to match that of the rotary selection switch of the CONNECT Dante device.

The **Dante Tab** presents the following Dante network bridge controls and information:

Refresh - Click the Refresh button to update the information from the CONNECT Dante unit.

Link or Duplex Indicator - Shows if a link is present on either the Primary or Secondary port.

MAC Address - The Primary and Secondary MAC Addresses.

IP Address - The IP Addresses of each network port.

Dante Device Name - Name of the CONNECT Dante unit set by the Dante Controller.

Channel Names - The fixed E-bus Channels (S through Z) and their correlating transmit and receive channel names as set by the Dante Controller.

Versions - The Dante version information.

CONFIGURATION MODE OVERVIEW

CONVERGE Console has two modes: **Configuration Mode** (default) and **Preset Mode**. Configuration Mode enables you to perform advanced configuration of devices to customize them to your specific application.

Accessing Configuration Mode

Console automatically starts in Configuration Mode with the Unit tab displayed as shown below.

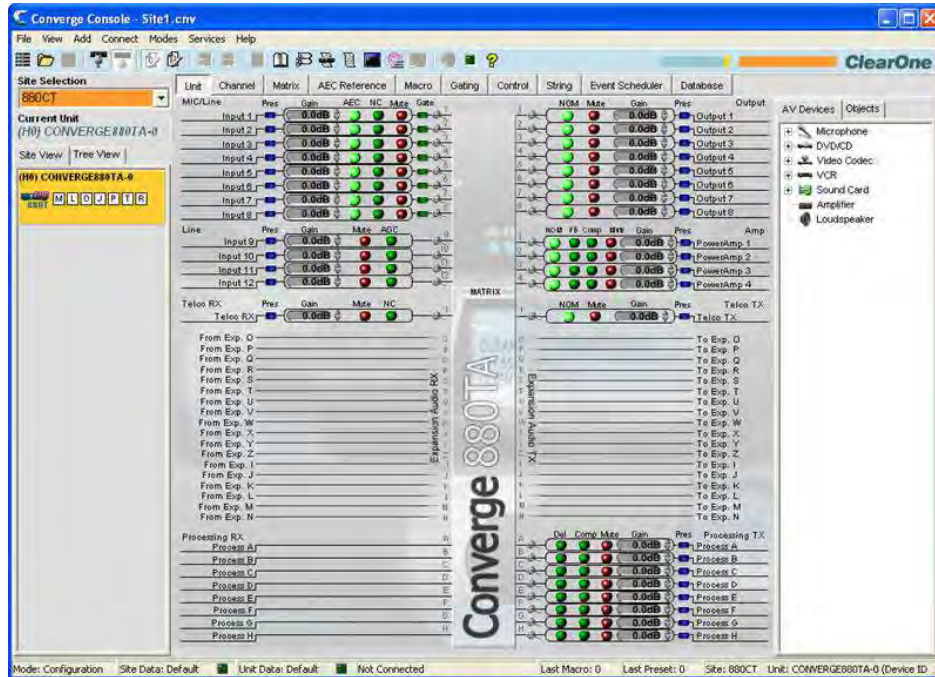

You can switch between modes by clicking on the **Mode**   buttons on the **Button Bar**. For a description of the Console screen components while in Configuration Mode, see *Navigating CONVERGE Console*.

Configuration Mode Tabs

Console has ten tabs on the Tab Bar that provide specific configuration options while in Configuration Mode:

- **Site**
- **Unit**
- **Channel**
- **Matrix**
- **AEC Reference/PA Adapt Reference Tab**
- **Macro**
- **Gating**
- **Control**
- **String**
- **Event Scheduler**
- **Database**

These tabs are described in the following sections.

SITE TAB

The **Site** tab shows a view of the site in the order the CONVERGE Pro units are connected with the Expansion Bus (E-bus). It displays the configured units in order of connection using the E-bus Link In and Link Out ports.

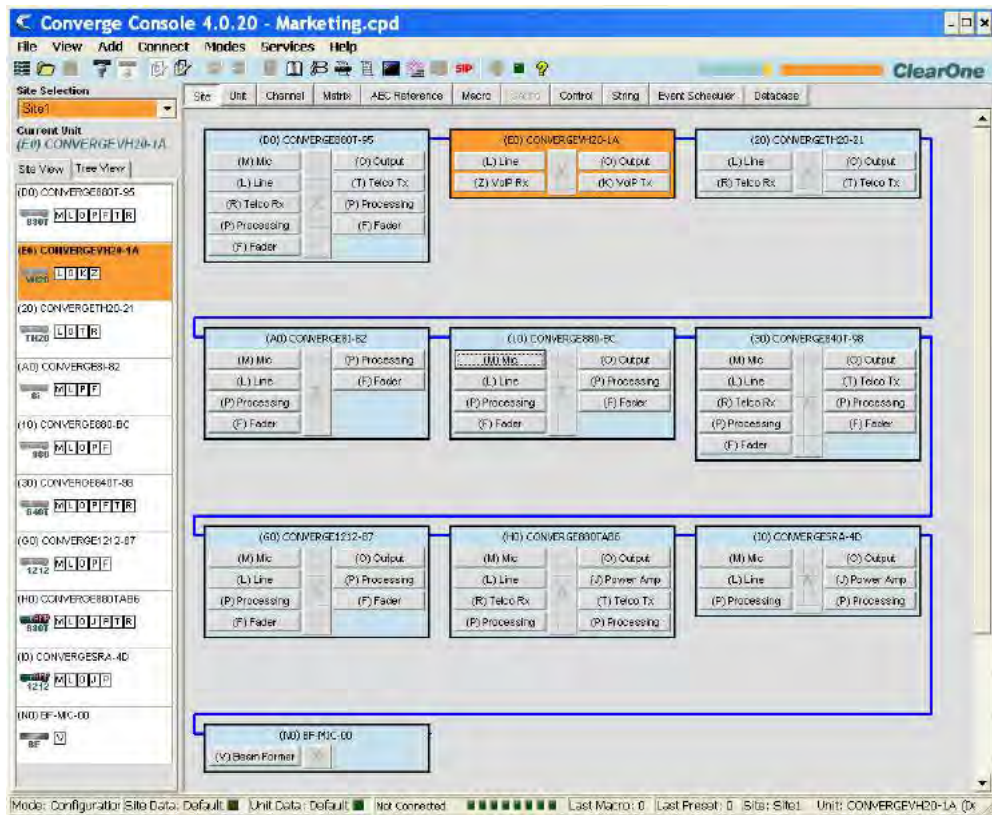

The Blue line shows the E-Bus connections. The E-bus In is on the left and the E-bus Out is on the right.

The currently selected unit is highlighted in orange. Use the Site pane or select a unit in the blue area to switch to the desired unit.

Clicking on a button within the unit boundaries will give options for further navigation.

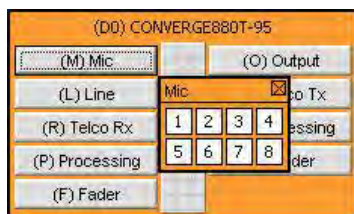

Clicking on the **number** will navigate to the selected Channel View. Click on the **box label** will open the **Group View** for the channel type.

UNIT TAB

The **Unit Tab** shows a detailed block diagram for the unit selected in the site pane. The diagram shows the path of the audio signal based on the current unit configuration, and provides a graphical explanation of each stage of audio processing.

Accessing the Unit Tab

Console automatically starts in Configuration Mode. When you load a site file, Console displays the Unit tab by default as shown below. To switch to the Unit tab from any other tab, click the **Unit** tab on the **Tab Bar**.

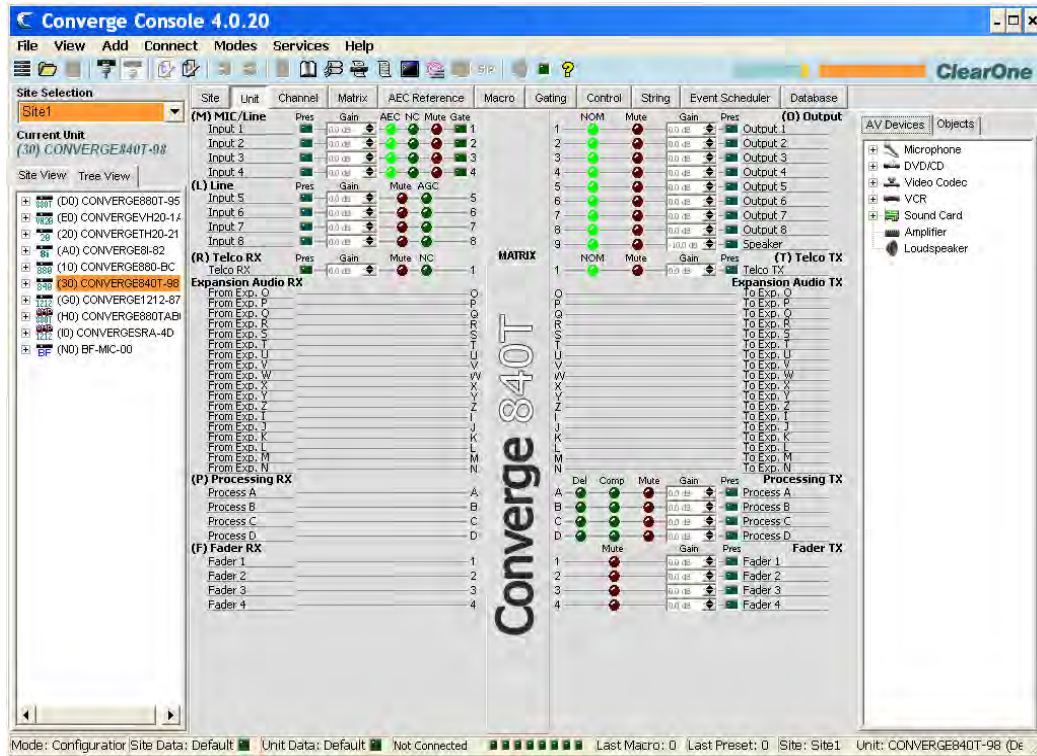

NOTE: The Unit tab shown above is for an 880AT with the Tree View tab selected in the Site Pane. All units that are connected and belong to the site also appear in the Tree View tab. The Unit tab display for other CONVERGE/CONVERGE Pro unit types will vary from that shown, depending on the number of inputs, outputs, Telco connections, etc. for the model selected.

Unit Tab Functionality

The graphical elements shown in the block diagram of the Unit tab provide shortcuts to the basic configuration settings for each channel type. For full configuration control of a channel, use the Channel tab.

For all channels in the Unit tab display, the blue **Pres** (Audio Presence) LEDs illuminate to indicate the presence of audio on the channel. For Mic Input Channels, the green Gate LEDs illuminate to indicate that the Mic is gated on.

The following sections describe the configuration setting shortcuts available in the Unit tab.

Input Channel Settings

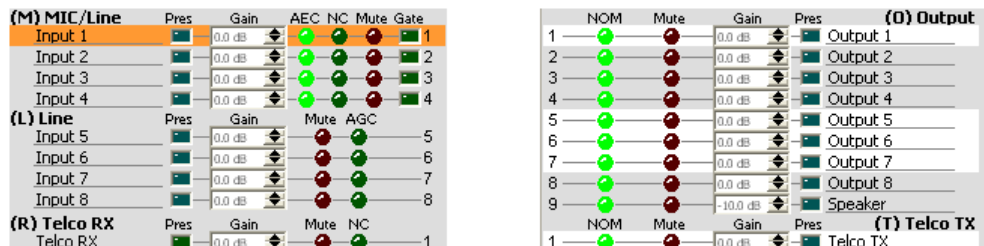

Pointing to an input channel on the left side of the screen highlights it in orange, and shows the routing for the channel in white on the right side of the screen (shown above). Clicking the channel selects it and displays the routing to other units in the site by channel type in the site pane (shown below).

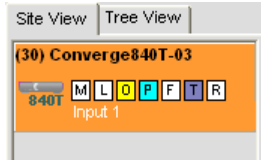

Set the desired Gain settings for the Input channel using the **Gain Arrows** to the right of the **Gain Display**. Toggle **AEC (Acoustic Echo Cancellation)**, **NC (Noise Cancellation)**, and **Mute** on and off by clicking the associated **LED Buttons**.

To access the full set of configuration settings for the channel, click on the Channel Label or number or letter of the channel next to the matrix.

Output Channel Settings

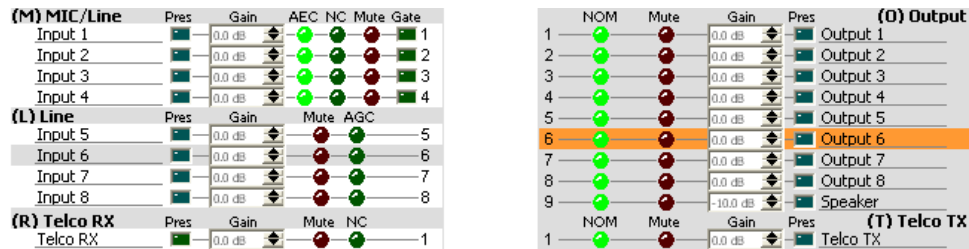

Pointing to an output channel on the right side of the screen highlights it in orange, and shows the routing for the channel in white on the left side of the screen (shown above). Clicking the channel selects it and displays the routing to other units in the site by channel type in the Site Pane (shown below).

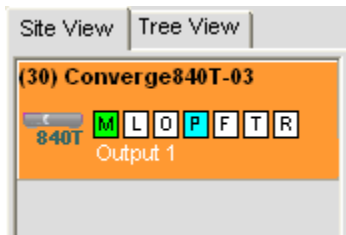

Set the desired Gain settings for the output channel using the **Gain Arrows** to the right of the **Gain Display**. Toggle **NOM (Number of Open Mics/Constant Level)**, and **Mute** on and off by clicking the associated **LED Buttons**.

To access the full set of configuration settings for the channel, click on the Channel Label or number or letter of the channel next to the matrix.

Processing Channel Settings

The screenshot displays the 'MATRIX' section of the Converge 880TA interface. It is organized into several columns and rows:

- (M) MIC/Line:** Inputs 1-8 with columns for Pres, Gain (0.0 dB), AEC, NC, Mute, and Gate.
- (L) Line:** Inputs 9-12 with columns for Pres, Gain (0.0 dB), Mute, and AGC.
- (R) Telco RX:** Telco RX with columns for Pres, Gain (0.0 dB), Mute, and NC.
- (O) Output:** Outputs 1-8 with columns for NOM, Mute, Gain (0.0 dB), and Pres.
- (J) Amp:** PowerAmp 1-4 with columns for NOM, FE, Comp, Mute, Gain (0.0 dB), and Pres.
- (T) Telco TX:** Telco TX with columns for NOM, Mute, Gain (0.0 dB), and Pres.
- Expansion Audio RX:** A list of expansion ports (O through N) with corresponding output letters (O through N).
- Expansion Audio TX:** A list of expansion ports (O through N) with corresponding input letters (O through N).
- Processing RX:** Processes A-H with columns for Del, Comp, Mute, Gain (0.0 dB), and Pres.
- Processing TX:** Processes A-H with columns for Del, Comp, Mute, Gain (0.0 dB), and Pres.

The 'Converge 880TA' logo is prominently displayed in the center of the matrix.

Pointing to a processing channel in the Matrix section of the screen highlights it in orange, and shows the routing for the channel in white (shown above). Clicking the channel selects it and displays the routing to other units in the site by channel type in the Site Pane (shown below).



Set the desired Gain settings for the processing channel using the **Gain Arrows** to the right of the **Gain Display**. Toggle **Del (Delay)**, **Comp (Compression)**, and **Mute** on and off by clicking the associated **LED Buttons**.

To access the full set of configuration settings for the channel, click on the Channel Label or number or letter of the channel next to the matrix.

Digital Microphone Input Processing

Beginning with CONVERGE Console 4.4.X, Digital Microphone Input Processing is included to enable processing CONNECT Dante or CONNECT CobraNet audio through the input stage instead of the audio on the analog inputs. This feature disables the rear panel analog Mic/Line inputs and instead the uses the audio coming in from a CONNECT Dante or CobraNet Bridge. This allows microphones on a Dante or CobraNet network to be processed using AEC, Noise Suppression, AGC, Filtering, Gating, etc.

With this enabled, the analog output audio is also mirrored to the digital outputs on the CONNECT Dante or CobraNet Bridge.

Fader Channel Settings

NOTE: The CONVERGE Pro 880TA and CONVERGE SR 1212A do not have fader settings.

The screenshot displays the 'MATRIX' section of the Convergence 840T interface. It is organized into several columns and rows:

- (M) MIC/Line:** Includes Input 1-4 with Pres, Gain (0.0 dB), AEC, NC, Mute, and Gate controls.
- (L) Line:** Includes Input 5-8 with Pres, Gain (0.0 dB), Mute, and AGC controls.
- (R) Telco RX:** Includes Telco RX with Pres, Gain (0.0 dB), Mute, and NC controls.
- Expansion Audio RX:** Lists expansion audio sources from O to N.
- (P) Processing RX:** Lists processing channels A, B, C, and D.
- (F) Fader RX:** Lists fader channels 1, 2, 3, and 4. Channel 1 is highlighted in orange.
- MATRIX:** A central grid with rows O through N and columns Q through Z.
- (O) Output:** Includes Output 1-8 and a Speaker, with Pres, Gain (0.0 dB), and Mute controls.
- (T) Telco TX:** Includes Telco TX with Pres, Gain (0.0 dB), and Mute controls.
- Expansion Audio TX:** Lists expansion audio destinations from O to N.
- Processing TX:** Lists processing channels A, B, C, and D with Del, Comp, Mute, Gain, and Pres controls.
- Fader TX:** Lists fader channels 1, 2, 3, and 4 with Mute, Gain, and Pres controls. Channel 1 is highlighted in orange.

Pointing to a fader channel in the Matrix section of the screen highlights it in orange, and shows the routing for the channel in white (shown above). Clicking the channel selects it and displays the routing to other units in the site by channel type in the Site Pane (shown below).

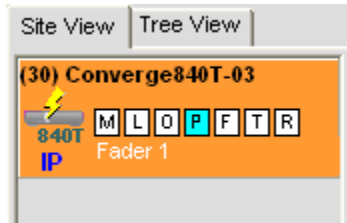

Set the desired gain settings for the fader channel using the **Gain Arrows** to the right of the **Gain Display**. Toggle mute on and off by clicking the associated **Mute LED Button**.

To access the full set of configuration settings for the channel, click on Channel Label or number or letter of the channel next to the matrix.

Expansion Audio RX and TX

The screenshot displays the audio control interface for the Converge 840T. It is divided into several sections:

- (M) MIC/Line:** Four input channels (Input 1-4) with controls for Presence, Gain (0.0 dB), AEC, NC, Mute, and Gate.
- (L) Line:** Four input channels (Input 5-8) with controls for Presence, Gain (0.0 dB), Mute, and AGC.
- (R) Telco RX:** One Telco RX channel with controls for Presence, Gain (0.0 dB), Mute, and NC.
- Expansion Audio RX:** A list of expansion channels (O to N) with orange highlights on 'O' and 'P'. The 'O' channel is selected, showing routing options to various expansion channels (P, Q, R, S, T, U, V, W, X, Y, Z, I, J, K, L, M, N).
- (P) Processing RX:** Four processing channels (Process A-D) with controls for Del, Comp, Mute, Gain (0.0 dB), and Presence.
- (F) Fader RX:** Four fader channels (Fader 1-4) with Gain (0.0 dB) and Presence controls.
- MATRIX:** A central section with a vertical 'Converge 840T' label. It shows routing for the selected 'O' channel to various expansion channels (O to N).
- (D) Output:** Eight output channels (Output 1-8) and a Speaker, each with Gain (0.0 dB) and Presence controls.
- (T) Telco TX:** One Telco TX channel with controls for NOM, Mute, Gain (0.0 dB), and Presence.
- Processing TX:** Four processing channels (Process A-D) with controls for Mute, Gain (0.0 dB), and Presence.
- Fader TX:** Four fader channels (Fader 1-4) with Gain (0.0 dB) and Presence controls.

Pointing to an **Expansion RX** or **Expansion TX** channel in the **Matrix** section of the screen highlights it in orange. Clicking the channel selects it and shows the **Input** (Tx channels only), **Output** (RX channels only), **Processing**, **Expansion**, and **Fader** channel routing (white highlights) for the selected channel as shown above.

Power Amp Channels (CONVERGE Pro 880TA and SR 1212A)

The CONVERGE Pro 880TA and SR 1212A units are equipped with four 35 watt amplifiers capable of running in either 8 ohm or 70/100 volt modes. Each amplifier operates independently to provide maximum flexibility.

Click the **Channel Tab** and refer to the Matrix Row. The four Power Amp channels are listed after the Outputs -- click any of the Power Amp channels to access the available options.

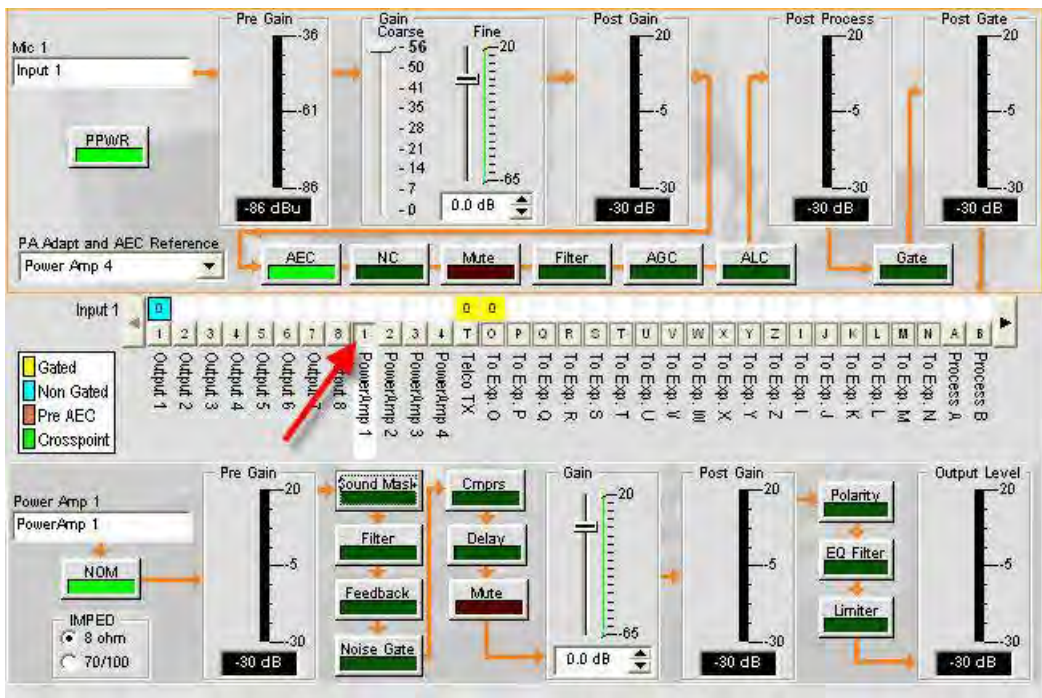

Options for the selected Power Amp appear below the Matrix row.

- **IMPED:** Selects the Power Amplifier's impedance. Options are 8 ohm and 70/100 volt.



- **Sound Mask:** Launches the **Sound Mask** pane.

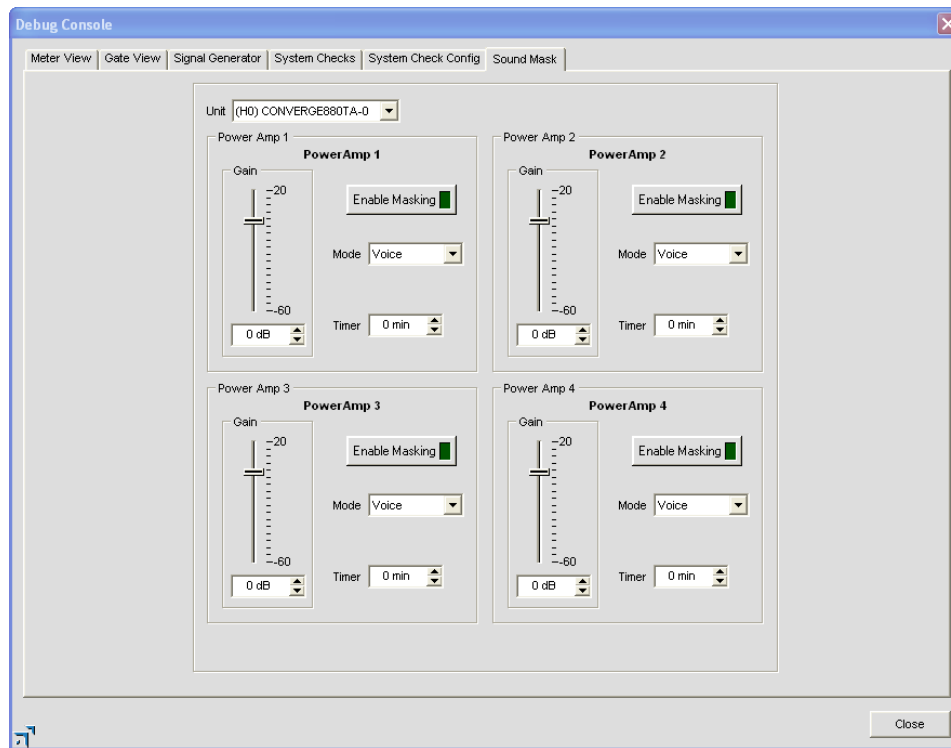

- » **Sound Masking** is an Amplifier Out only feature consisting of three modes:
 1. **Off:** Disables the feature
 2. **Voice:** Masking operates only in the range usually used when the target audio is vocal.
 3. **Wideband:** Masking operates throughout the audible range of the unit.

- **Filter:** Filters selected from the Power Amp channel are only applied to the amplifier. Otherwise they operate in any combination consistent with the Processing channel filters.

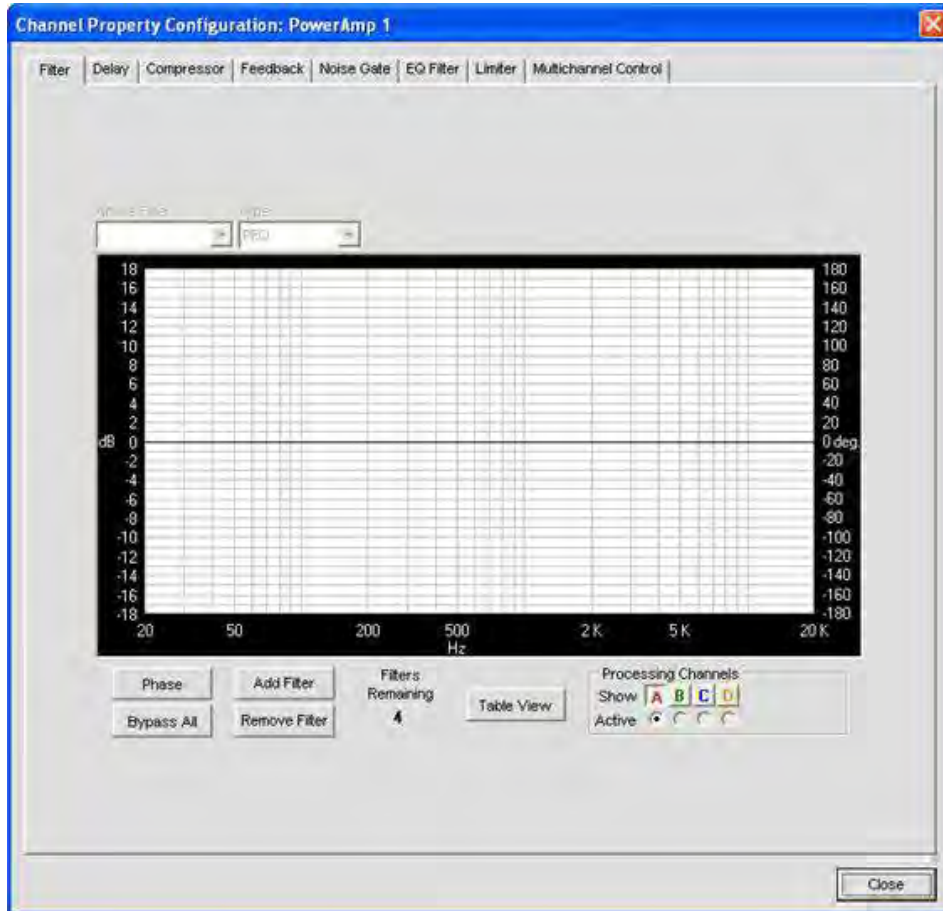

- **Feedback:** Launches the Feedback window.

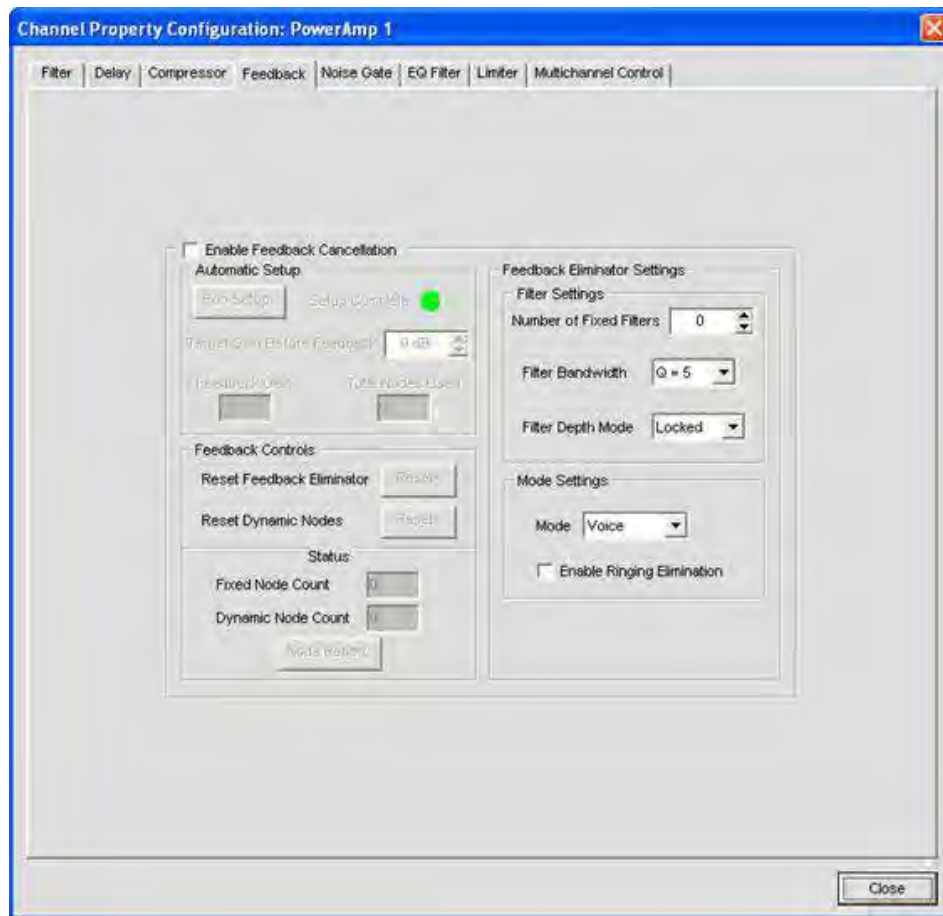

- This feature allows you to reduce feedback through a simple configuration window.

1. **Enable Feedback Cancellation:** Enables or Disables the feature.
2. **Automatic Setup:** Creates notch filters based on your choice of Feedback Cancellation settings.
 - » **Target Gain Before Feedback:** Set your desired dB rating. The unit slowly increases dB, adding notch filters at detected feedback frequencies until it either reaches the target level or reaches the number of **Fixed Filters** (specified in the **Filter Settings - Number of Fixed Filters**). The system detects feedback through an open mic while levels are increased. If the target is reached without using the specified number of fixed filters, the remaining “slots” are used as Dynamic Filters to be applied as the environment changes.
 - » **Feedback Controls:**
 - **Reset Feedback Eliminator:** Clicking Reset clears all settings related to this feature.
 - **Reset Dynamic Nodes:** Clicking Reset only clears dynamic filters; Fixed Filters remain in place.
 - » **Status:** Reports the number of Fixed and Dynamic nodes. A total of 16 nodes can be used, regardless of type.
 - **Node Report:** Creates a text report listing existing node details.

» **Feedback Eliminator Settings:**

- **Filter Settings:** Filters are applied according to the specifications the user sets.

» **Number of Fixed Filters:** Up to 16 Fixed Filters are applied. If the specified number of filters are not required, they become Dynamic Filters.

» **Filter Bandwidth:** Bandwidth is determined by the specified Q factor. A lower Q creates a filter that works across a wider frequency range. A higher Q utilizes a narrower range.

» **Filter Depth Mode:**

- Locked re-uses filters. A replacement filter, with new settings and increased filter depth is applied in place of an existing filter.
- Unlocked adds a new filter at a specific frequency. No filters are replaced, so this setting will count against the total number of filters available.

» **Mode Settings:** Voice and Music presets are available to fine-tune the feedback eliminator.

NOTE: Voice Mode is the more aggressive setting.

» **Enable Ringing Elimination:** Allows the Feedback Cancellation to attempt to suppress ringing.

NOTE: This setting adjusts slowly to eliminate ringing.

3. Click Close to close the window once the Setup Complete indicator has switched from yellow (in process) to green (setup complete).

- **Noise Gate:** This feature reduces buzz and hum from the amp when the system is on but not in use.

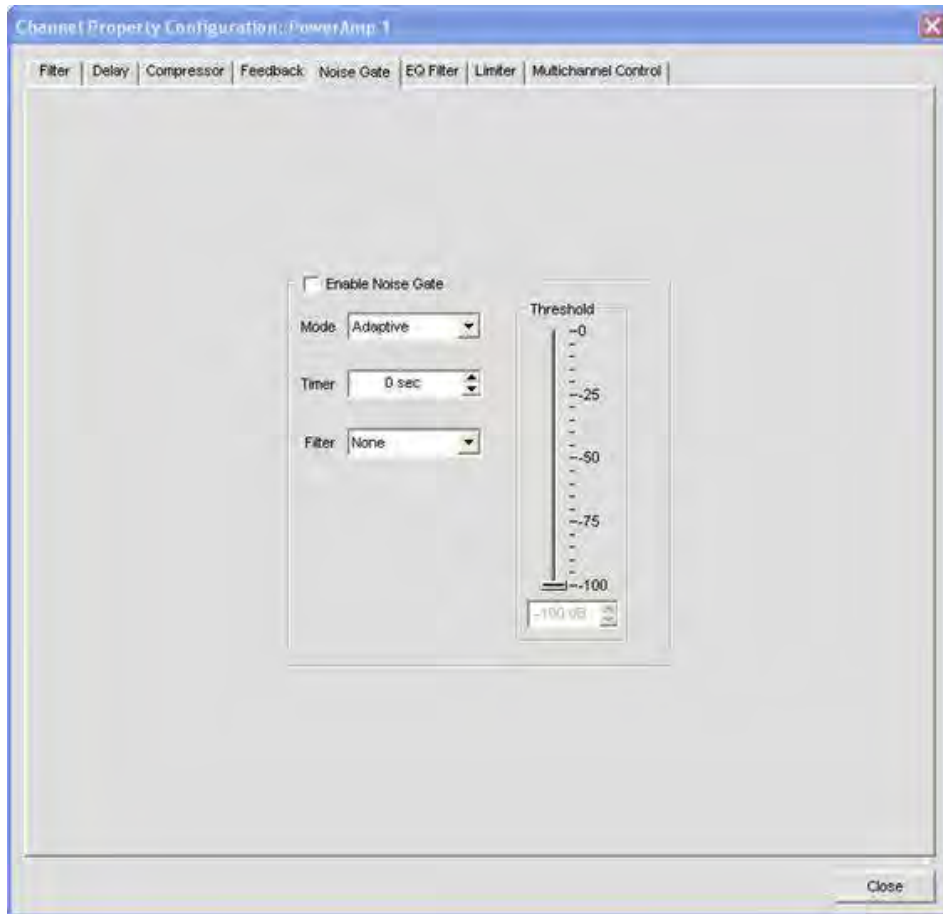

1. Enable Noise Gate: Enables or Disables the feature.

» **Mode:**

- **Adaptive:** Actively monitors the noise floor of the environment and determines when to enable gating.
- **Manual:** User sets Threshold.

» **Timer:** Time before the Amp begins gating.

NOTE: The Noise Floor must be at the Threshold Level for the duration set in the **Timer** in order to enable the Noise Gate.

» **Filter:**

- **None:** No filtering is applied to noise.
- **High Pass:** A High Pass filter is applied to noise before threshold reading.
- **Low Pass:** A Low Pass filter is applied to suppress noise before threshold reading.
- **High/Low Pass:** High and Low Pass filtering is applied to noise before threshold reading.

- **Compressor:** Allows the user to enable compression on an amp channel based on configurable parameters. With a few exceptions (noted below) this feature operates identically to the **Processing Compressors**.

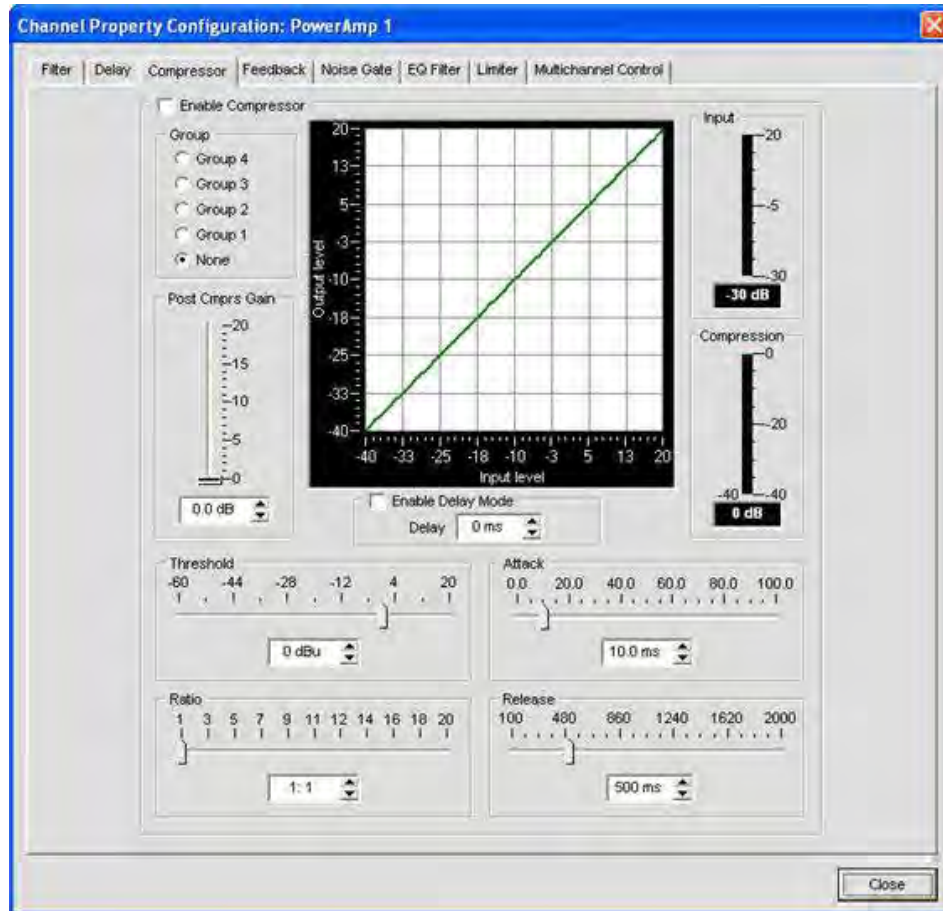

- » **Delay Mode:** Enabling Delay Mode sets a timed delay after which the Compressor activates. Timing ranges from 0 to 20ms.

Note: Groups do not interact with Processor channels.

- **Mute:** Mutes the specific Power Amp channel.
- **Polarity:** Reverses the amplifier's output polarity.
- **EQ Filter:** Adjusts specific frequency bands within a +/-12db range.
 - » **Enable EQ Filter:** Enables or disables the EQ.

- **Limiter:** Establishes a ceiling level for the amplifier output.

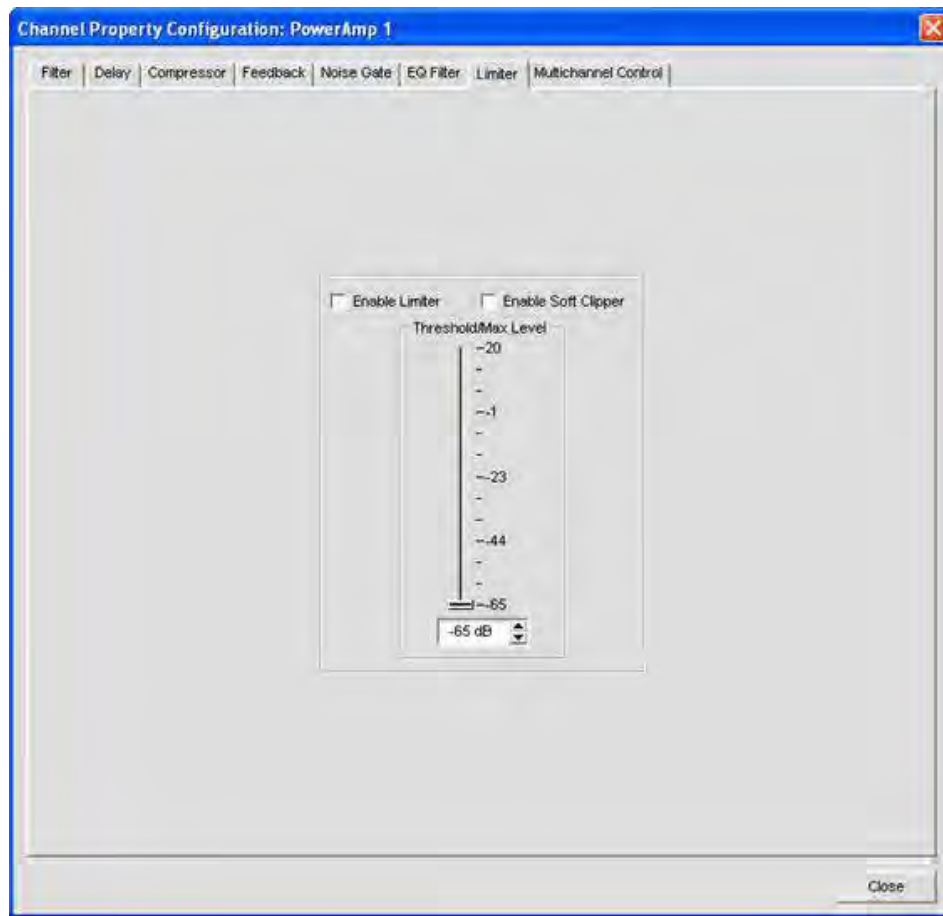

- » **Enable Limiter:** Limits the output to the **Threshold/Max** Level specified by the user.
- » **Enable Soft Clipper:** Softens the clipping effect at **Threshold/Max** level to prevent damage to external equipment.

Note: Both settings can be active simultaneously.

- **Multichannel Control:** Multichannel Control is only available on amplifier channels. Each of the 4 amplifiers can be assigned to one of two Multichannel groups. When amplifier channels are assigned to a Multichannel group, Mute and Gain for the group are controlled from a single point.

NOTE: Multiple PA Channel Selections cannot be applied to both groups simultaneously. If you assign PA 1 and 3 to Multichannel Group1, those amplifiers cannot be assigned to Multichannel Group 2 without removing them from the first group.

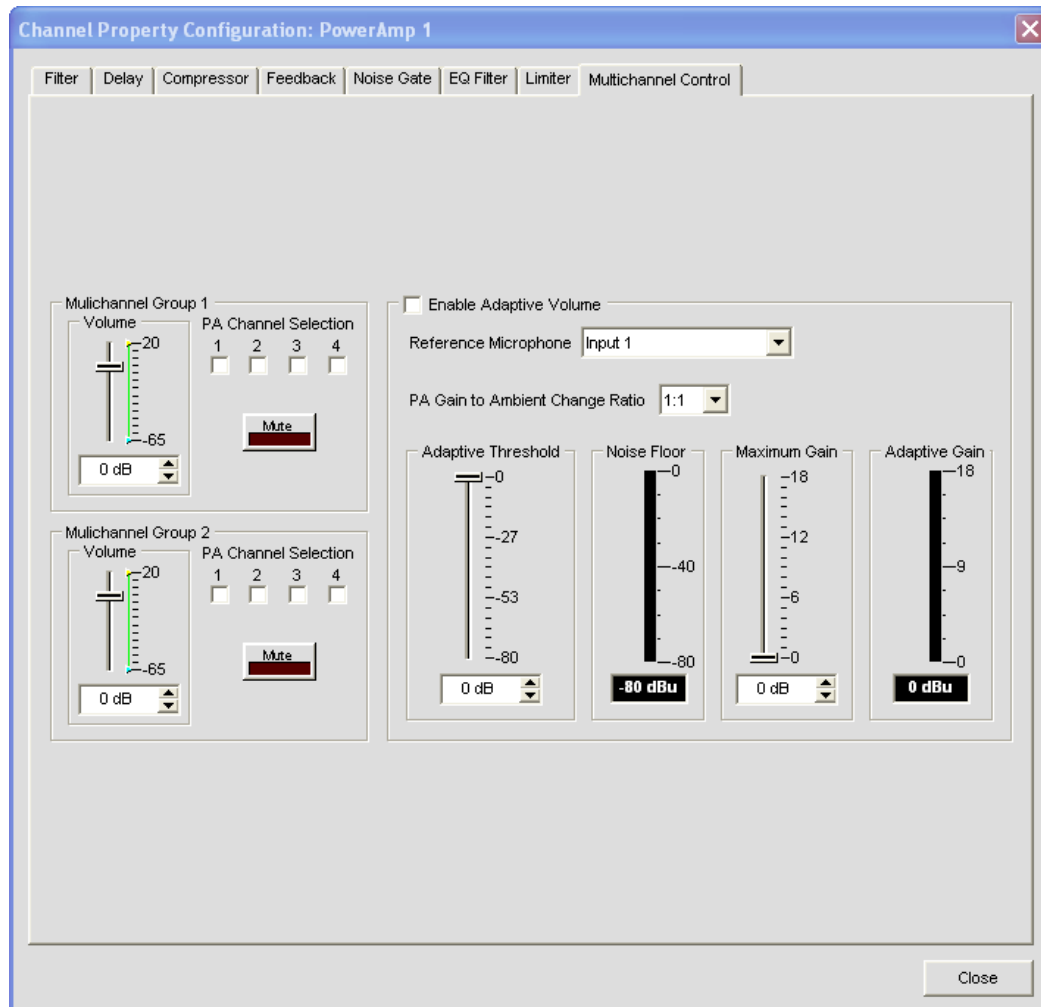

- **Volume:** Indicates the volume level assigned to the Multichannel Group
- **PA Channel Selection:** Each box represents a PA Channel. Check the box you wish to assign to the corresponding Multichannel Group.
- **Mute:** Mutes the Multichannel Group
- **Enable Adaptive Volume:** When enabled the level of the PA Channel will adjust based on the **Noise Floor** "heard" by the selected reference microphone. As the level of noise changes, the output level adjusts according to the selected **PA Gain to Ambient Change Ratio**. For example, if the rate is set to 2:1 the amplifier level will adjust by 2 dB for every 1 dB in noise for increase. The gain applied is governed by the **Maximum Gain** setting. Before any gain is applied the noise floor heard by the mic must be equal to or greater than the **Adaptive Gain** setting.

For more information, refer to the *Table of Contents* for these related topics:

- **AEC (Auto Echo Cancellation)**
- **NC (Noise Cancellation)**
- **Configuration Mode**
- **Channel Tab**
- **Matrix Tab**
- **Processing Settings**
- **Fader Settings**

CHANNEL TAB OVERVIEW

The **Channel** section of Console makes the full set configuration controls available for a given channel, from input to processing to output. The type of channel selected in the Tree View tab of the Current Unit pane determines the contents of the Channel pane in the center of Console.

The channels available in the Tree View tab are:

- **Mic Input Channels**
- **Line Input Channels**
- **Telco/VoIP Rx Channel**
- **Output Channels**
- **Telco/VoIP Tx Channel**
- **Processing Channels**
- **Fader Channels**

Accessing Channel Tab

Selecting a channel in the Tree View tab displays the Channel Tab for that channel. For example, the channel tab for a mic channel is shown below:

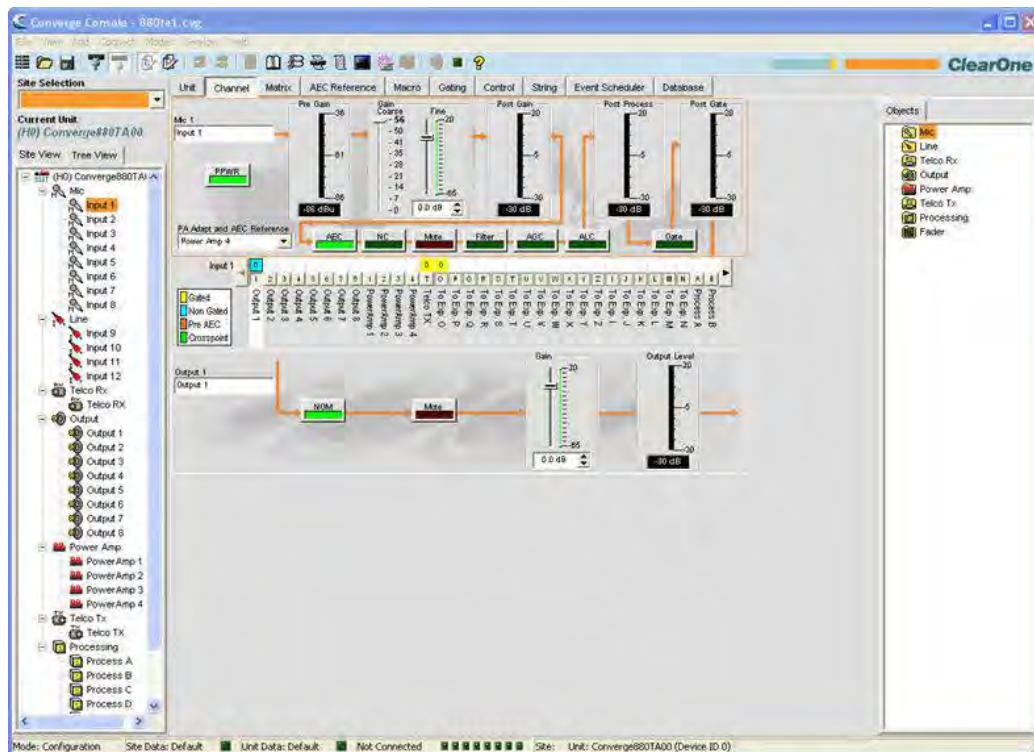

Channel Configuration Controls

As shown above, the configuration settings for a channel are displayed as controls (buttons, sliders, check-boxes, selection lists, text entry boxes) in the Channel pane. Use the text entry boxes to assign custom names. Use the drop-down lists to select from a list of configuration values. Use the sliders to set a discrete value for channel configuration parameters.



Some buttons, such as the PPWR (Phantom Power) button shown above, toggle features on and off.

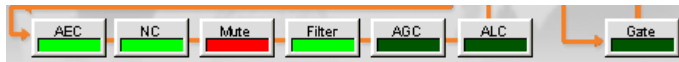

Other buttons, including AEC (Acoustic Echo Cancellation), NC (Noise Cancellation), Filter, AGC (Automatic Gain Control), ALC (Automatic Level Control), shown above, bring up the Channel Property Configuration screen shown below.

Channel Property Configuration Screen

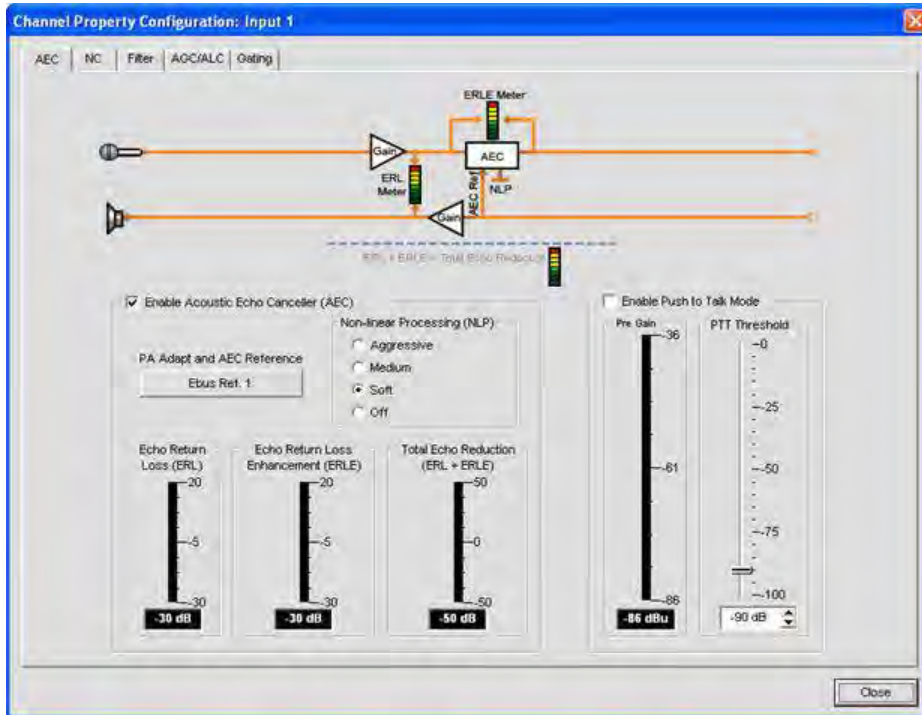

The Channel Property Configuration screen is used to configure Mic Input, Line Input, and Processing channels. The tabs available in this screen change depending on the type of channel selected in the Tree View pane of Console.

Meters

In addition to the configuration controls available in the Channel pane, there are meters showing signal levels in real time at each stage of signal processing. The meters shown change with the type of channel selected. For example, the meters for Mic Input channels are shown below:

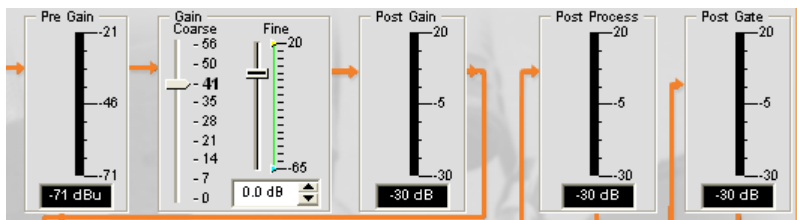

NOTE: All meters in Console are peak-level meters.

Channel Routing Matrix

The channel routing matrix of the Channel pane shows the associated Matrix row and routing configuration for the channel selected in the Tree View tab of the Current Unit pane. The channel routing matrix of the Channel pane for a Mic Input channel is shown below.



Use the routing legend to determine the current cross-point configuration of the selected input channel. As shown in the example above, Input 1 is non-gated and cross pointed by default to Output 1. It is also gated and cross pointed by default to Outputs 5-7, Telco/VoIP Tx, and Exp Bus O.

Clicking a cross point box selects it, clicking it a second time sets the cross point, as indicated by a colored box. The dB level for set cross points is shown numerically in the box. To adjust cross point gain/attenuation, right-click on a cross point box and select **Cross Point** from the shortcut menu as shown below.

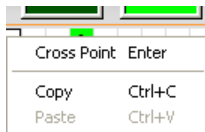

The **Cross Point Attenuation** slider appears as shown below. Move the slider or use the selector box to set the gain/attenuation level in dB. The range is from -60 to +12dB in .5dB increments. The default is 0dB.

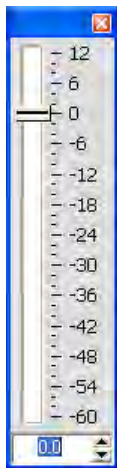

NOTE: Changes are automatically saved when you close the slider.

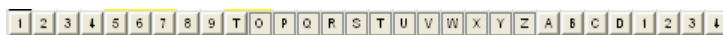

In the channel routing matrix section of the Channel pane, pressing the channel button underneath an Output, Process, or Fader cross point box (shown above) displays the signal flow diagram and configuration controls for that channel (shown below).

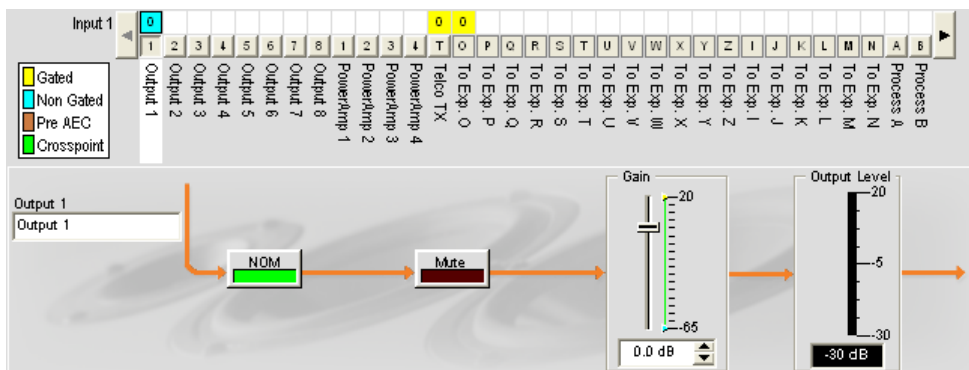

This display is identical to that shown on the Channel Tab when the channel is selected in the **Tree View** pane.

NOTE: Changes to channel configuration settings made in the channel routing matrix apply globally to the channel. For example, changing the label (name) from “Output 1” to “Ceiling Speakers” changes the name of the output channel in the Tree View pane, and everywhere else the label appears in Console.

Beamforming Microphone Channel

Beamforming Configuration is used to define the mode and pickup zones of the selected Beamforming Microphone Array.

Click on the **Beam Forming Configure** button on the Channel control of a selected Beamforming Microphone Array.

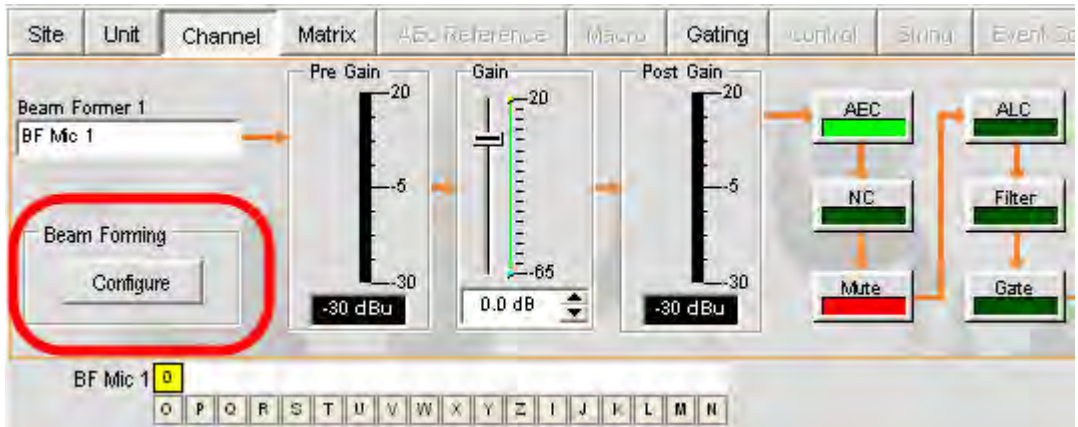

Beamforming Microphone Orientation

Shown below is a configuration with Ceiling Mount as the selected mode. It displays the zones where the microphones in the array pickup audio when the microphone array is mounted from the ceiling. (Table Mount and Wall Mount modes will be available with a future firmware upgrade.)

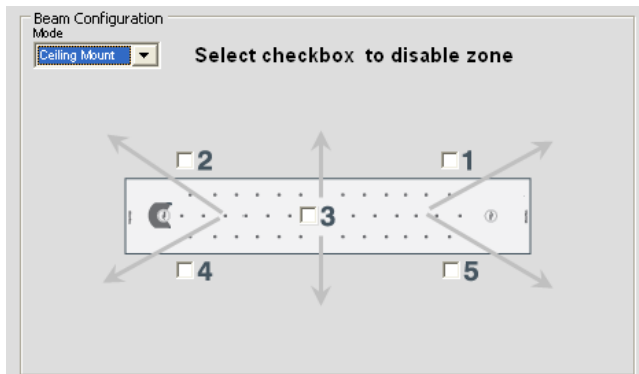

The Auto mode allows the Beamforming Microphone Array to select its own mode by referencing a built-in accelerometer that senses the position of the microphone array. However, this is not displayed in the Console.

Zone Disabling

Clicking on the checkbox associated with a zone in a mode will disable that zone, removing it from microphone pickup. This is useful in customizing the zone to the room conditions where the Beamforming Microphone Array is used.

For additional information, refer to the *Table of Contents* for these related topics:

- **Mic Input Channel**
- **Line Input Channels**
- **Telco/VoIP Rx Channel**
- **Output Channels**
- **Telco/VoIP Tx Channel**
- **Processing Channels**
- **Fader Channels**
- **AEC (Acoustic Echo Cancellation)**
- **NC (Noise Cancellation), Filter**
- **AGC (Automatic Gain Control)**
- **ALC (Automatic Level Control)**
- **Mic Gating**
- **Filters**
- **Site Pane**
- **Objects Pane**

AEC (ACOUSTIC ECHO CANCELLATION)

AEC (Acoustic Echo Cancellation) reduces or removes acoustical echo from an input signal, thereby improving audio clarity. CONVERGE Pro devices perform AEC using the full bandwidth (20hz to 22kHz) of the signal.

AEC uses a reference source to perform AEC based on the acoustic characteristics and dynamics of a specific room. Use the AEC Reference/PA Adapt Reference tab to set up these references.

Accessing AEC

With the **Channel** tab selected on the **Tab Bar**, select the desired **Mic Input** channel on the **Tree View** tab in the **Site Pane**, and press the **AEC** button (located just below the Pre Gain meter).

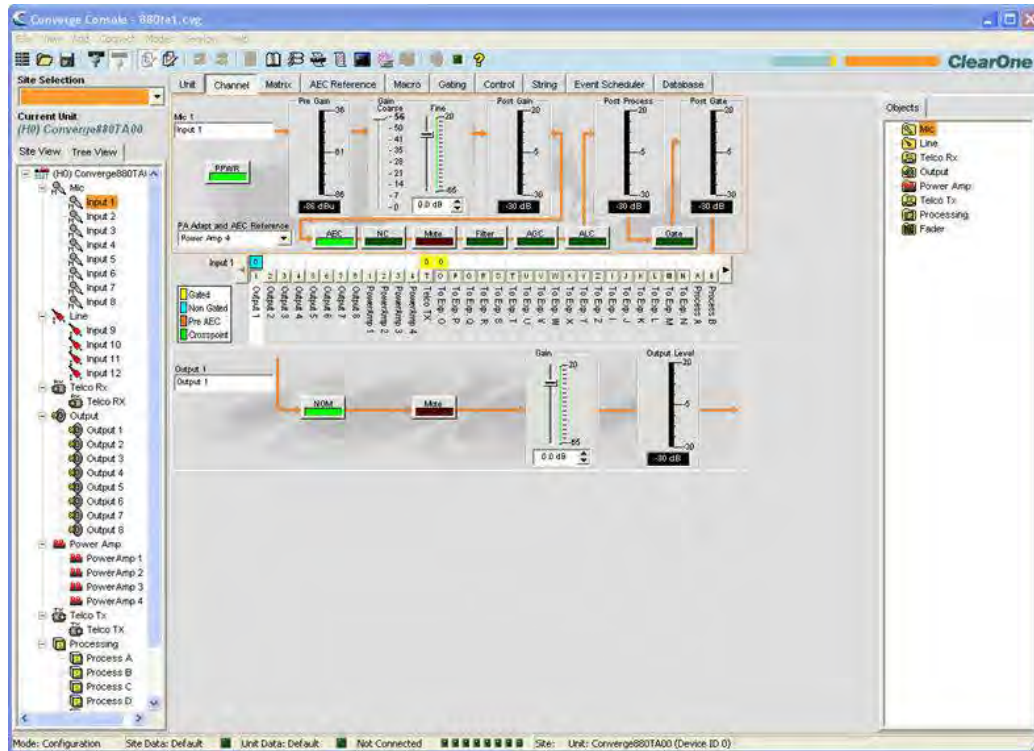

The **Channel Property Configuration** screen appears with the **AEC** tab selected (see below).

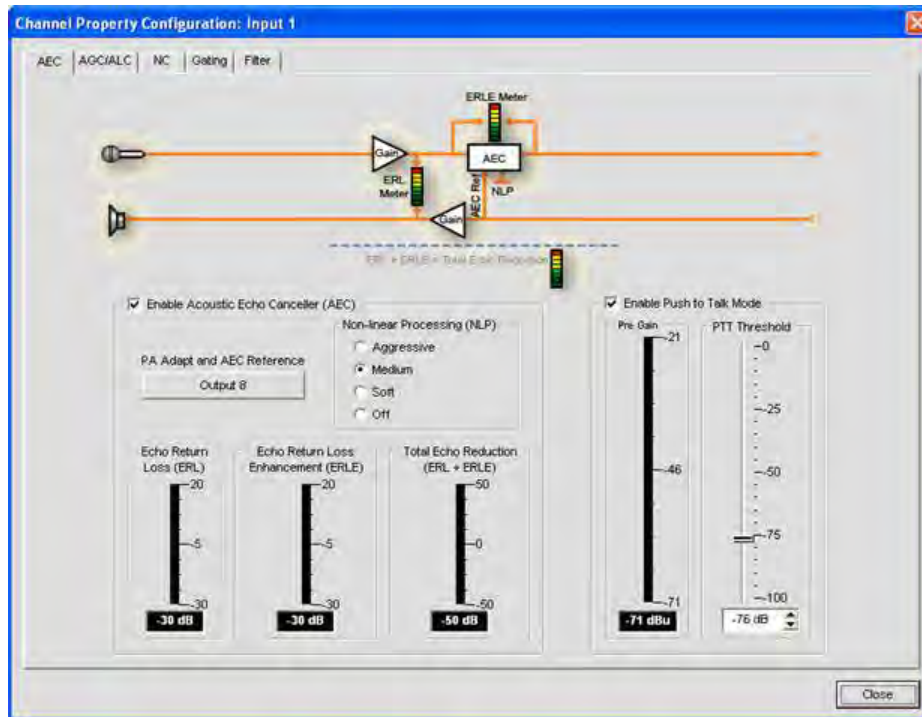

The AEC tab shows a signal flow diagram for AEC, and has the following features: Enable AEC, PA Adapt and AEC Reference, NLP (Non-linear Processing), and PTT (Push-to-Talk) mode. These features are described in the following sections.

Enable AEC Checkbox

Select the checkbox to enable AEC.

PA Adapt and AEC Reference Button

This button displays the expansion bus output channel currently used as the AEC reference for the selected channel. Clicking the button closes the Channel Property Configuration window and opens the AEC Reference tab in the center pane of Console.

NLP (Non-Linear Processing) Radio Buttons

NLP increases the power of echo cancellation for difficult acoustical environments. NLP features four settings: Soft, Medium, Aggressive, Off. The default is soft.

NOTE: Use NLP with care. There are corresponding trade-offs associated with NLP, including suppression and half-duplex operation.

The AEC tab also includes meters for **Echo Return Loss (ERL)**, **Echo Return Loss Enhancement (ERLE)**, and **Total Echo Reduction (ERL + ERLE)**.

ERL (Echo Return Loss) Meter

Shows the coupling between the reference signal and the input to the echo canceller—the difference of the two levels. This is an average meter that updates when a receive-only signal is present.

ERLE (Echo Return Loss Enhancement) Meter

Shows the loss through the echo cancellation and non-linear processing chain—the difference of the two levels. This is an average meter that updates when a receive-only signal is present.

ERL + ERLE Meter

Shows the total **ERL and ERLE** reduction. This is an average meter that updates only when a receive-only signal is present.

PTT (Push to Talk) Mode

Select the **Enable Push to Talk Mode** checkbox to enable PTT. PTT notifies AEC when a microphone is switched off, and freezes AEC convergence until the microphone is switched back on. As a result, PTT helps prevent AEC divergence and improves overall AEC performance with push to talk microphones.

When the microphone is off, set the **PTT Threshold** slider to the level of the **Pre-Gain Meter** for the channel.

Beamforming Microphone AEC Controls

The AEC controls on the Beamforming Microphone Array differ in that an HD Mono AEC or Stereo AEC mode is selected and one or two Ebus References can be selected; One reference for mono, two for stereo. The selection is made from 8 Ebus References. There is no PTT mode.

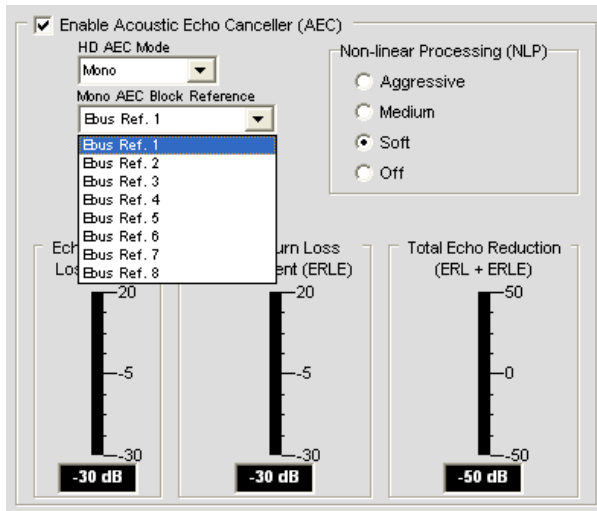

For additional information, refer to the *Table of Contents* for these related topics:

- **AEC Reference/PA Adapt Reference Tab**
- **AGC/ALC (Automatic Gain Control/Automatic Level Control)**
- **NC (Noise Cancellation)**
- **Mic Gating**
- **Filters**
- **Line Input Settings**
- **Mic Input Settings**

NC (NOISE CANCELLATION)

NC (Noise Cancellation) is a process in which ambient (background) noise is removed from an input signal, with no noticeable degradation in signal quality. NC is available on Mic Input (excluding SR 1212 and SR 1212A) and Telco/VoIP Rx channels.

Accessing NC

With the **Channel** tab selected in the **Center Pane**, select the desired Mic Input channel on the **Tree View** tab in the **Site Pane**, and press the **NC** button (located just below the **Coarse Gain** slider).

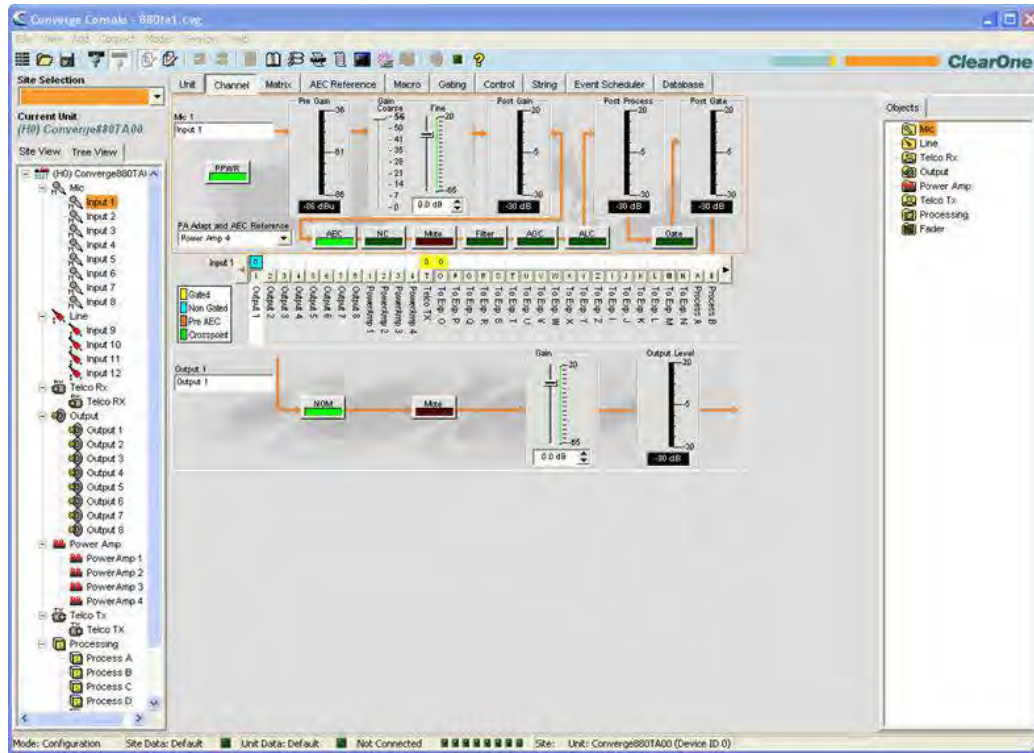

The **Channel Property Configuration** screen appears with the **NC** tab selected as shown below.

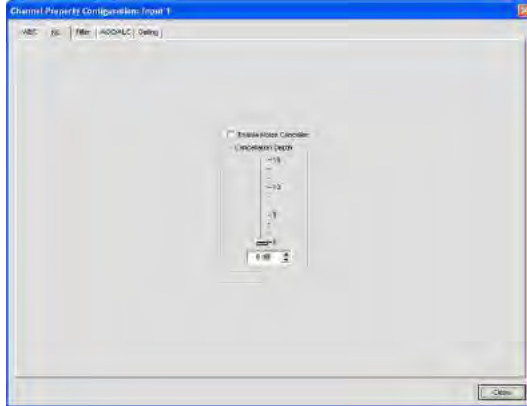

Configuring Noise Cancellation

Select the **Enable Noise Canceller** checkbox to enable NC for the channel. Adjust the **Cancellation Depth** slider to the dB setting which provides the best combination of low noise and maximum speech clarity. The cancellation depth can also be set using the arrow buttons or by entering a value directly in the field. The attenuation depth can be set in 1dB increments from 6dB to 15dB. The default is 6dB. The default NC is Off.

For additional information, refer to the *Table of Contents* for these related topics:

- **Channel Tab Overview**
- **AEC (Acoustic Echo Cancellation)**
- **AGC/ALC (Automatic Gain Control/Automatic Level Control)**
- **Mic Gating**
- **Filters**
- **Mic Input Settings**
- **Telco/VoIP Rx Settings (TH20, VH20, 840T, 880, 880T, 880TA)**

FILTERS

Filters enable you to shape the audio signals from Mic Input channels for improved audio quality.

There are four configurable filter types available:

- All Pass
- High Pass
- Low Pass
- Notch
- PEQ (Parametric Equalizer)

Accessing Filters

With the **Channel** tab selected on the **Tab Bar**, select the desired input channel on the **Tree View** tab in the **Site Pane**, and press the **Filter** button (located just below the **Post Gain** meter).

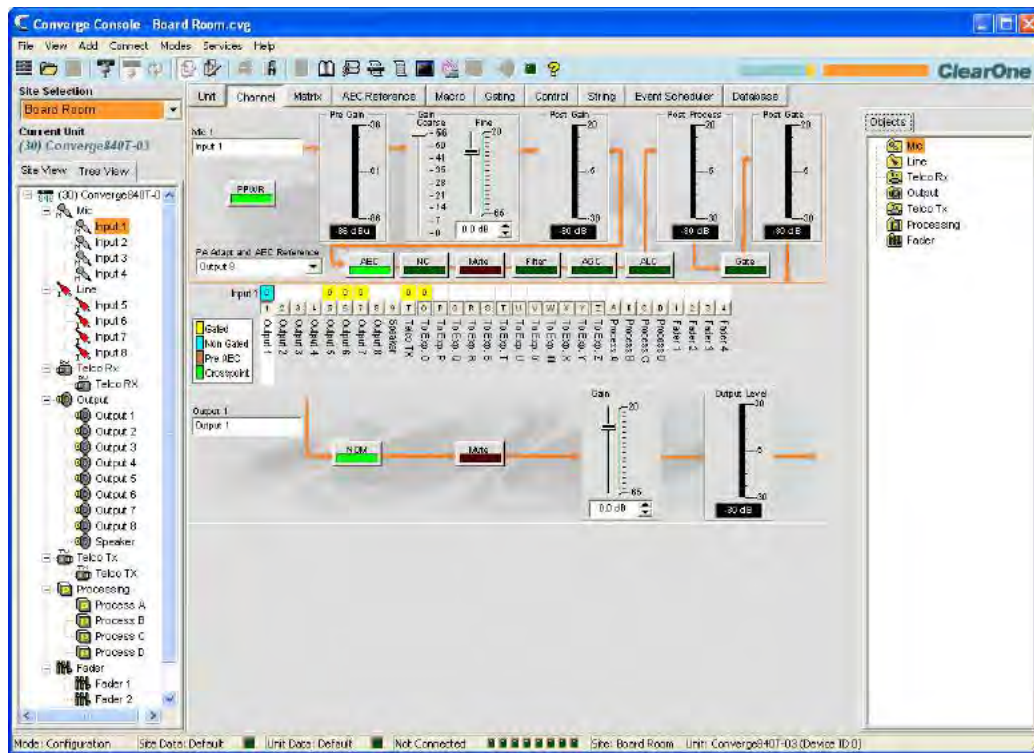

The **Channel Property Configuration** screen appears with the **Filter** tab selected as shown below.

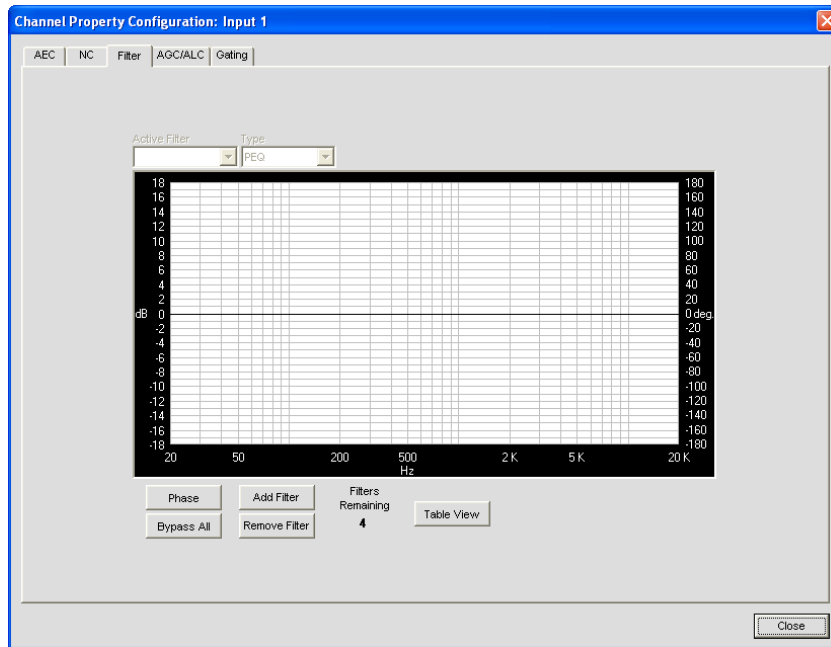

The following sections describe how to configure and activate input channel filters.

Active Filter

Use the **Active Filter** drop-down list to select among active filters. Selecting a filter highlights its node on the graph and displays its current settings. You can configure up to four active filters per input channel.

NOTE: There are no filters configured by default. Press the **Add Filter** button to create a filter for the input channel. When you add a filter, it appears in the **Active Filter** drop-down list, and on the active filter graph.

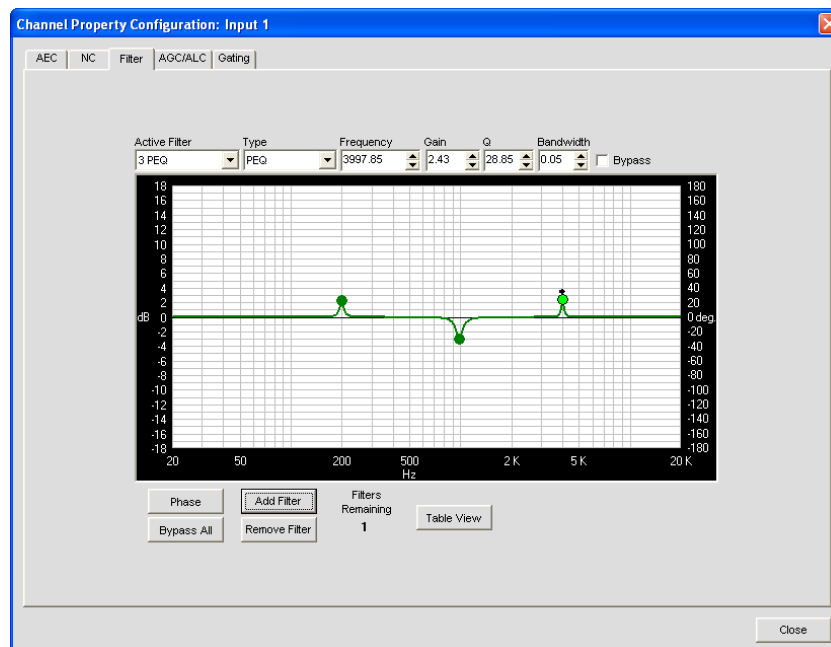

In graph view, you can click on a filter node and drag it to the desired location on the graph. The setting fields immediately reflect changes made by dragging filter nodes.

Filter Nodes

In graph view, you can click on a filter node and drag it to the desired location on the graph. The setting fields immediately reflect changes made by dragging filter nodes.

Filter node colors represent the following:

- **Green:** The filter node is selected and active. Dragging a green node changes the gain setting for PEQ filters and the frequency for all filter types.
- **Grey:** The filter node is selected but not active.
- **White:** The filter node is not selected and not active.
- **Black:** Dragging a black filter node changes bandwidth settings for Notch and PEQ filter types.

Adding Filters

To add additional filters, click the **Add Filter** button. The number of remaining available filters for the channel is shown under **Filters Remaining**.

Filter Types

Use the Type drop-down list to select from the following input filters:

- **All Pass.** Frequency range is 20.00Hz to 20.00kHz. All pass changes the phase of the audio signal at the set frequency.
- **High Pass.** Selectable frequency cutoff is 20.00Hz to 20.00kHz. Rolloff is 12dB/octave. Level is fixed at 0dB.
- **Low Pass.** Selectable frequency cutoff is 20.00Hz to 20.00kHz. Rolloff is 12dB/octave. Level is fixed at 0dB.
- **Notch.** Center frequency range is 20.00Hz to 20.00kHz. Bandwidth is from .05 to 5.00 octaves in .01 octave increments. Level is fixed at -80dB.
- **PEQ (Parametric Equalizer).** Center frequency range is 20Hz to 20kHz in .01Hz increments. Bandwidth is .05 to 5 octaves in .01 octave increments. Level range is -15 to +15dB in 0.5dB increments.

Frequency (Available for all filter types)

Use the **Frequency** selector box to set the center frequency (in Hertz) for the filter you are configuring. Range is from 20Hz to 20kHz in 1Hz increments. The default is 1kHz.

Gain (Available for PEQ filters only)

Use the **Gain** selector box to set the gain value for the filter you are configuring. Range is from -15 to 15dB. The default is 0dB.

Q (Available for Notch and PEQ filters only)

Use the **Q** (Quality Factor) selector box to select the ratio of the center frequency divided by the bandwidth. Q is the inverse of bandwidth, and the two parameters are linked. Therefore changing the Q value also changes the bandwidth value. Range is from .18 to 28.85.

Bandwidth (Available for Notch and PEQ filters only)

Use the **Bandwidth** selector box to set the difference between the upper and lower points of a filter's audio passband. Bandwidth is the inverse of Q, and the two parameters are linked. Hence changing the bandwidth value also changes the Q value. The range is .05 to 5.00 octaves.

Bypass (Available for all filter types)

Use the **Bypass** checkbox to bypass the currently selected active filter. This feature allows you to configure different filters and save them for future use without having to recreate them.

Phase

Press the **Phase** button to display the phase relationship of the graphed frequency response (appears as a grey line on the active filter graph). The phase scale appears on the right vertical axis of the graph.

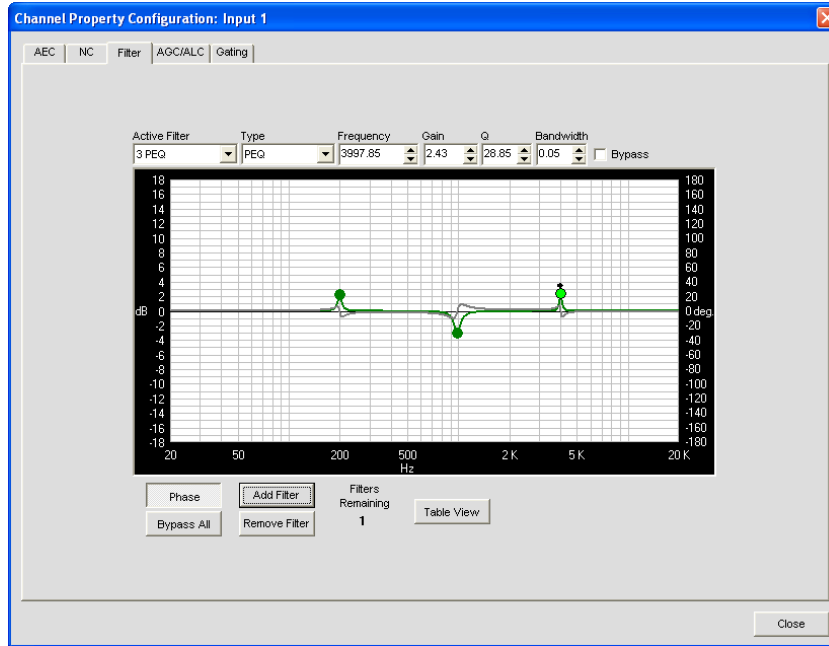

Bypass All

Press the **Bypass All** button to bypass all filters for the selected input channel. The filters are grayed out in graph view, and the bypass status is shown as on in table view.

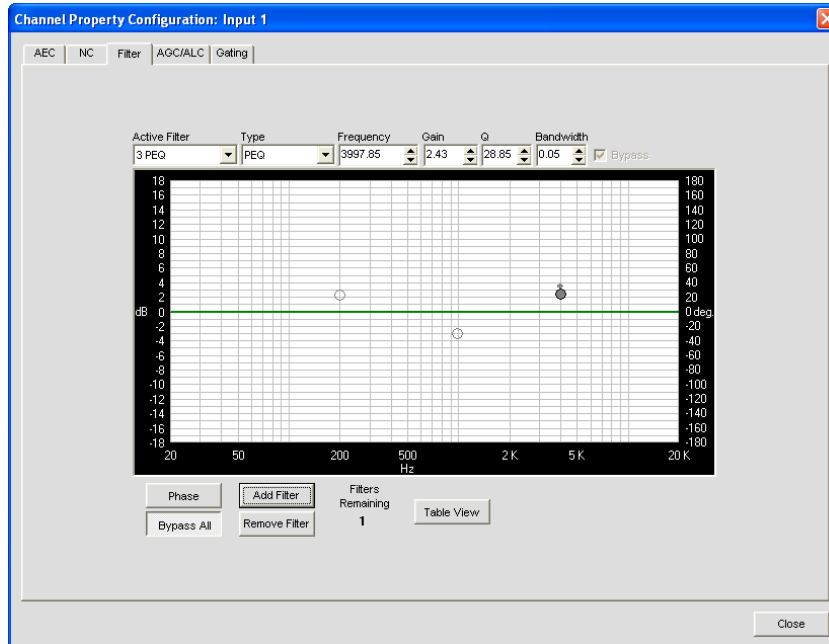

Add Filter

Press the **Add Filter** button to create a filter for the input channel. When you add a filter, it appears in the **Active Filter** drop-down list, and on the active filter graph. You can configure up to four active filters per input channel. The number of remaining available filters for the channel is shown under **Filters Remaining**.

Remove Filter

Press the **Remove Filter** button to remove the filter currently selected in the Active Filter drop-down list. Removing a filter increments the **Filters Remaining** by one.

Table View

Press the **Table View** button to toggle the display between graph view and table view. Table view displays filter settings in table format for all filters configured for the input channel. Clicking on a row in table view selects the filter, displays the current settings for that filter, and allows you to edit the values in the setting fields. Changes made in the setting fields are immediately reflected in the table.

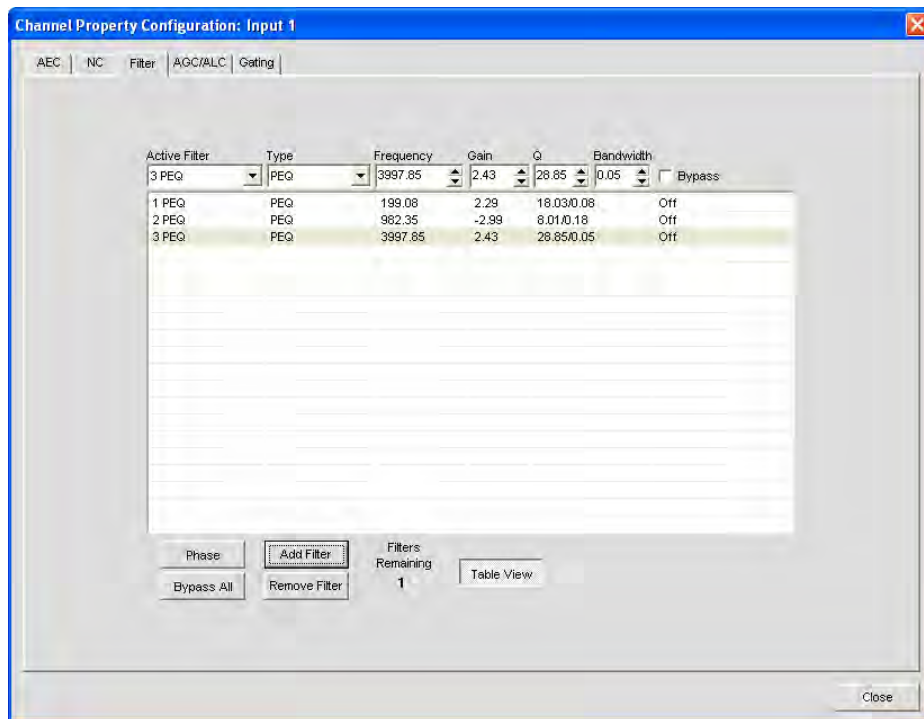

For additional information, refer to the *Table of Contents* for these related topics:

- **Channel Tab Overview**
- **AEC (Acoustic Echo Cancellation)**
- **AGC/ALC (Automatic Gain Control/Automatic Level Control)**
- **NC (Noise Cancellation)**
- **Mic Gating**
- **Mic Input Settings**

AGC/ALC (AUTOMATIC GAIN CONTROL/AUTOMATIC LEVEL CONTROL) TAB

AGC/ALC enables AGC or ALC and allows you to configure AGC settings for the selected input channel. Either AGC or ALC can be enabled—you cannot use them both at the same time.

AGC keeps an input signal at a target gain level that you select, and is generally used for Line Input channels.

ALC automatically keeps an input signal at a constant level, and is generally used to keep speech levels constant on Mic Input channels.

Accessing AGC/ALC

With the **Channel** tab selected on the **Tab Bar**, select the desired **Mic input** channel on the **Tree View** tab in the **Site Pane**, and press either the **AGC** or **ALC** button (located just below the **Post Gain** meter).

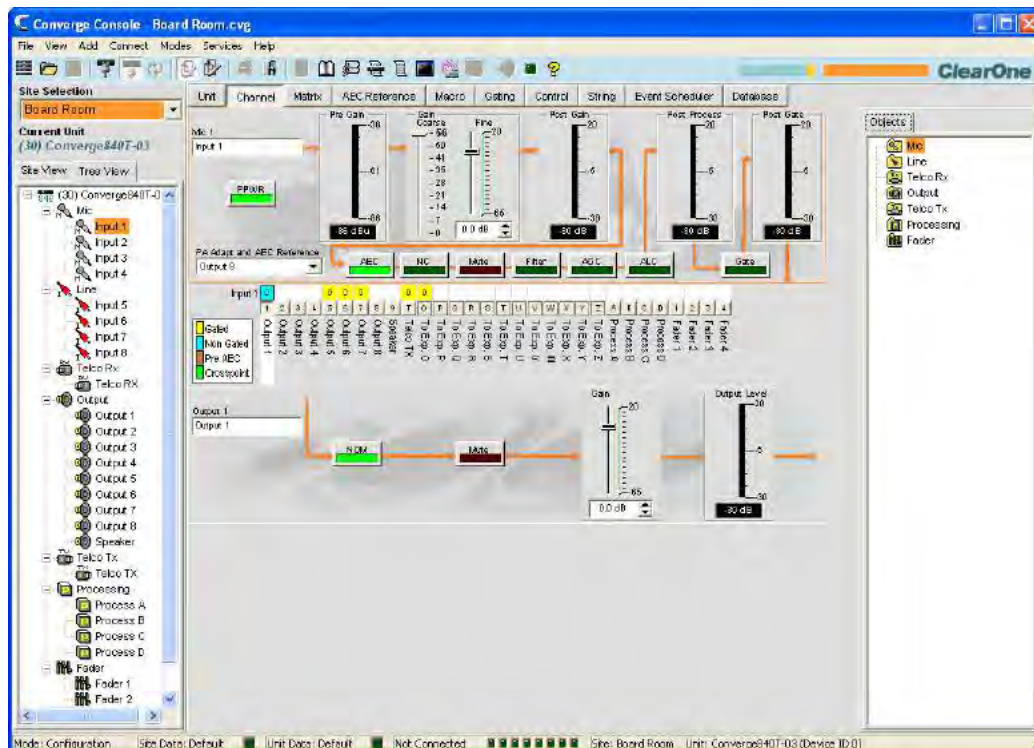

The **Channel Property Configuration** screen appears with the **AGC/ALC** tab selected as shown below:

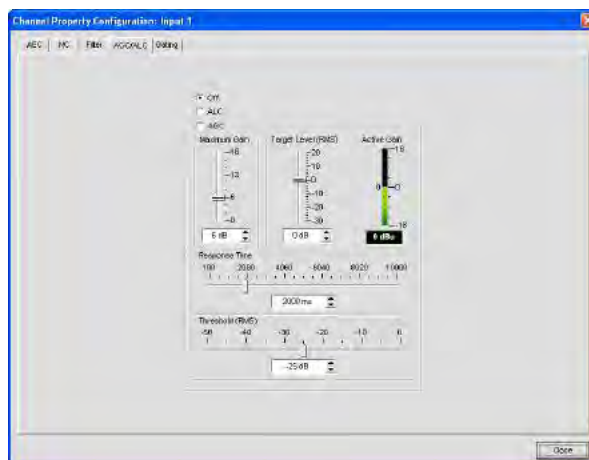

Use the **AGC/ALC** radio buttons to select **Off**, **ALC**, or **AGC**. The default is Off. ALC is performed automatically; there are no user-configurable settings for ALC.

NOTE: AGC occurs after gain and filter settings in the audio signal path.

The configuration controls for AGC are described in the following sections.

Maximum Gain Slider

Set the **Target Level** first, then set the **Maximum Gain** that you want the AGC to apply to the signal. Maximum Gain is set using an RMS (Root Mean Square) level, which is the average magnitude of the audio signal over time. Maximum Gain range is 0 to 18dB in 1dB steps. The default value is 6dB.

Target Level Slider

Target Level (RMS) sets dB level for AGC to maintain. Target Level range is from -30 to 20dB in 1dB steps. The default target level is 0dB.

Active Gain Meter

The **Active Gain Meter** displays the gain adjustment being applied to the channel by AGC.

Response Time Slider

Response Time sets the amount of time (in milliseconds) over which the level is averaged before AGC is activated or deactivated.

Threshold Slider

Threshold sets the dB level at which AGC engages. The Threshold is set using an RMS (Root Mean Square) level, which is the average magnitude of the audio signal over time.

NOTE: Setting the Threshold above the background noise level will prevent AGC from amplifying background noise.

For additional information, refer to the *Table of Contents* for these related topics:

- **Channel Tab Overview**
- **AEC (Acoustic Echo Cancellation)**
- **NC (Noise Cancellation)**
- **Mic Gating**
- **Filters**
- **Line Input Settings**
- **Mic Input Settings**

MIC GATING

The **Gate** button on the **Channel** tab enables you to configure gating control for individual **Mic Input** channels, and assign them to **Gating Groups**. There are two types of gating for Mic Input channels: **Auto Gating** and **Manual Gating**.

For more information about Gating Groups, see the **Gating Tab** section.

Accessing Channel Gating Configurations

With the **Channel** tab selected on the **Tab Bar**, select the desired **Mic Input** channel on the **Tree View** tab in the **Site Pane**, and press the **Gate** button (located just below the **Post Process** meter).

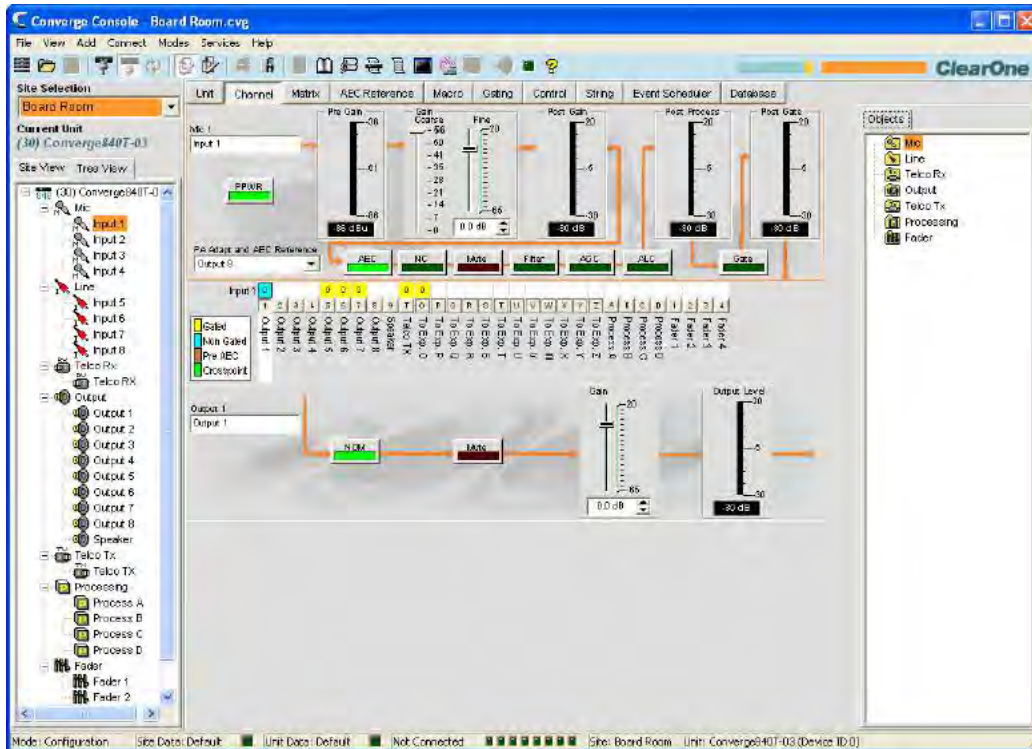

The Channel Property Configuration screen appears with the Gating tab selected.

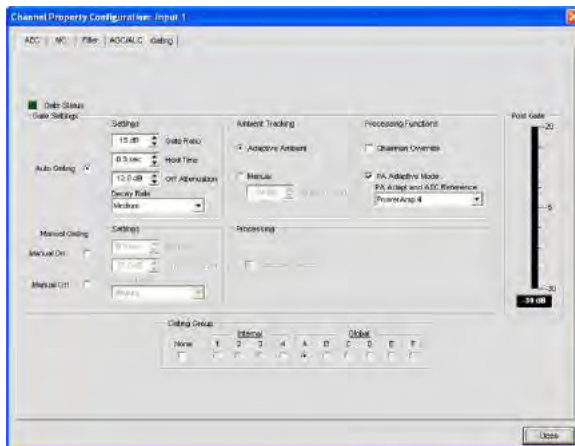

Use the radio buttons to select **Auto Gating**, **Manual On** or **Manual Off**, which are described in the sections below.

Gating Settings: Auto Gating

The upper section of the Gate Settings section of the screen contains the gating controls for Auto Gating as shown below.



Auto Gating: Settings

- **Gate Ratio:** Specifies how much louder than the ambient level the audio level must be before the channel automatically gates on. The gate ratio range is from 0 to 50dB. The default is 15dB.
- **Hold Time:** Determines how long the channel stays gated on after the audio falls below the Gate Ratio threshold. The hold time range is from .1 to 8.0 seconds. The default is .3 seconds.
- **Off Attenuation:** Sets the amount of level reduction applied to a channel when it is gated off. The range is from 0 to 60dB. The default is 12dB.
- **Decay Rate:** Determines how fast a channel gates off after the Hold Time expires. The default is Medium.

NOTE: Changing Hold Time, Off Attenuation, and Decay Rate also changes the same settings under Manual Gating.

Auto Gating: Ambient Tracking

- **Adaptive Ambient:** Adjusts the ambient reference level as noise and room conditions change. When Adaptive Ambient is on, the mic channel monitors the ambient noise level on the input and adjusts the ambient level reference automatically. This means that the gate threshold level automatically increases or decreases based on background noise. The default is On.
- **Manual:** When Adaptive Ambient is set to **Manual**, the input will use the fixed ambient level you specify in the **Ambient Level** field as its gating reference.

Auto Gating: Processing Functions

- **Chairman Override:** Provides gating priority for this mic input over any other mic input within the same gating control (mixer) group. When a mic with Chairman Override enabled gates on, all mics which do not have Chairman Override enabled will gate off. The default is Off.
- **PA Adaptive Mode:** Uses the audio level on a specified output as the new ambient level when audio is present at the power amplifier. This prevents loudspeaker audio from gating on the mic while still allowing people in the room to gate on microphones when they speak (provided that their voices are louder than the loudspeaker audio). For example, you might decide to play background music from a CD player during a presentation. PA Adaptive Mode allows you to use the output routed from the CD player as the ambient reference to prevent the CD player's audio from gating on microphones. The default is on.
- **PA Adapt and AEC Reference:** When **PA Adaptive Mode** is selected, you must define the output that will be used as the reference source for PA adaptation and Acoustic Echo Cancellation (AEC). Select a source in the **PA Adapt and AEC Reference** drop-down list. You can use any one of the outputs, expansion bus references, virtual references, or speaker output channels as the reference.

Gate Settings: Manual Gating

The lower section of the **Gate Settings** section of the screen contains gating configuration controls for **Manual Gating** as shown below.



Manual Gating: Manual On/Manual Off

Select the **Manual On** radio button to gate the channel on, or **Manual Off** to gate the channel off. Off gating behavior is controlled by the settings described in the next section.

Manual Gating: Settings

- **Hold Time:** Determines how long the channel stays gated on after the channel is manually gated off. The hold time range is from .1 to 8.0 seconds. The default is .3 seconds.
- **Off Attenuation:** Sets the amount of level reduction applied to a channel when it is manually gated off. The range is from 0 to 50dB. The default is 12dB.
- **Decay Rate:** Determines how fast a channel gates off after the Hold Time expires. The default is Medium.

NOTE: Changing **Hold Time, Off Attenuation, and Decay Rate** also changes the same settings under **Auto Gating**.

Both Auto Gating and Manual Gating are affected by Gating Group membership as described in the next section.

Gating Groups

In addition to specifying gating characteristics for each **Mic Input** channel, you can assign the channel to a **Gating Group** for greater flexibility and control. When inputs are assigned to a gating group, the gating information from the inputs is used to control how the entire mixer behaves. Gating Groups are created and defined using the **Gating Tab** on the **Tab Bar** in Console.

The 880, 880T, 880TA 840T, 8i, SR 1212 and SR 1212A feature four internal gating groups (**Internal 1–4**) and six global gating groups across the expansion bus (**Global A–F**). Mic Inputs can only be used in one gating group at a time. If an input is not assigned to a gating group, that mic's gating properties are independent, and they have no effect on any gating group. When gating groups span two or more units (global gating groups), the settings must be the same for each unit attached to the global gating group.

NOTE: Input channels can be assigned to one and only one **Gating Group** at a time.

Mic Inputs are routed to **Global Group A** by default. To assign a gating group, select an **Internal** or **Global** radio button in the **Gating Group** section of the screen, or select **None** to have the Mic Input gate independently of any gating group.



Post Gate Meter



The **Post Gate Meter** displays the audio level of the selected channel after Auto or Manual Gating settings are applied. Meter range is from -30 to +20dB.

For more information, refer to the *Table of Contents* for these related topics:

- **Gating Tab**
- **AEC (Acoustic Echo Cancellation)**
- **AGC/ALC (Automatic Gain Control/Automatic Level Control)**
- **NC (Noise Cancellation)**
- **Filters**
- **Line Input Settings**
- **Mic Input Settings**
- **Beamforming Microphone Configuration**

MIC INPUT SETTINGS

Mic Input Settings enable you to customize mic input channel settings using the **Channel** screen.

Accessing Mic Input Settings

With the **Channel** tab selected on the **Tab Bar**, select the desired mic input channel on the **Tree View** tab in the **Site Pane**.

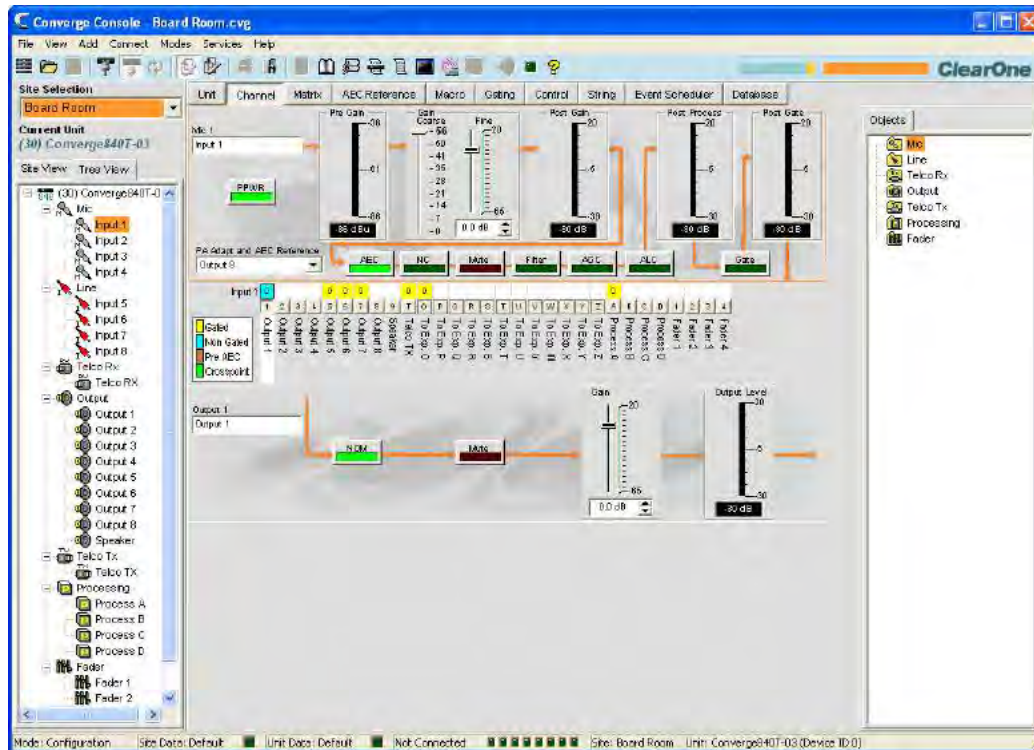

The center pane displays a signal processing diagram, meters, and configuration controls for the selected mic input channel as shown above. Note that the meters and configuration controls are shown at the appropriate point in the signal path.

The meters and configuration controls for mic input channels are explained in the following sections.

Channel Label



Rename the channel by entering a name in the **Label** entry field (optional). Label changes are global, and appear throughout Console wherever the label is referenced.

PPWR (Phantom Power)



The **PPWR (Phantom Power)** button toggles phantom power on and off. Phantom power is an auxiliary power source used to power certain types of microphones. Phantom power voltage is 24VDC. The default is On.

Pre Gain Meter

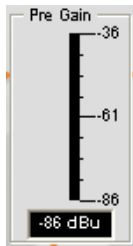

The Pre Gain meter displays the mic input level before gain adjustments. Meter range is determined by the Coarse Gain Slider in the Gain section of the screen as described below.

NOTE: All meters in Console are peak-level meters.

Gain Section

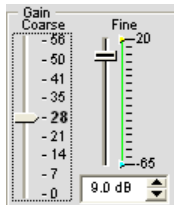

The **Coarse** and **Fine** gain sliders are used to match the level settings between mic inputs, and to adjust the volume level for a given mic input channel. The **Min/Max** fine gain sliders are used to set minimum and maximum gain settings, and to report min/max gain settings via serial commands.

In general, you should set the **Coarse** gain slider to 56dB for a mic input, 28dB for active equipment that requires an input between mic and line level, or 0dB for a line level input device.

Use the **Fine** gain slider to adjust input volume level. You can also set fine gain in .5dB increments using the **Up/Down** buttons, or enter a value directly in the field.

Post Gain Meter

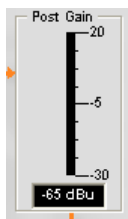

The **Post Gain Meter** displays the audio level after gain adjustments.

Post Process Meter

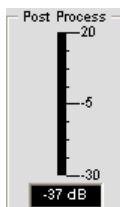

The Post Process Meter displays the audio level after it passes through all mic input processing, such as Processing channels, Filters, AEC, NC, AGC/ALC, and Mute.

Post Gate Meter

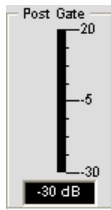

The **Post Gate Meter** displays the audio level after gating. Channel gating for mic inputs is configured on the **Gating** tab of the **Channel Property Configuration** window for mic input channels, which is described in the next section.

Channel Configuration Buttons



The **Channel Configuration Buttons** enable you to configure the available features for mic input channels. With the exception of the **Mute** button, which toggles muting, clicking a channel configuration button displays the **Channel Property Configuration** window. Each feature is shown on a tab in the window that corresponds with the configuration button shown in the **Center Pane**.

For example, clicking the **AEC** button displays the Channel Property configuration window with the **AEC** tab selected as shown below:

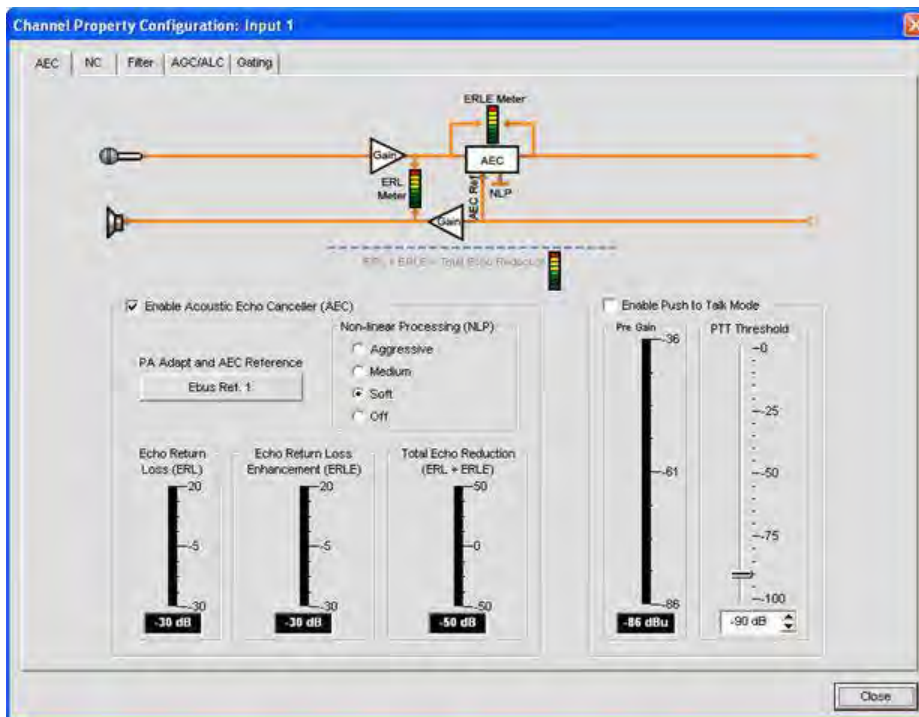

For more information on each configuration feature, see the following topics:

- **AEC (Acoustic Echo Cancellation)**
- **AGC/ALC (Automatic Gain Control/Automatic Level Control)**
- **NC (Noise Cancellation)**
- **Mic Gating**
- **Filters**
- **Beamforming Microphone Configuration**

Channel Routing Matrix: Inputs

The channel routing matrix section of the **Channel** screen shows the matrix row and audio routing configuration for the selected input channel (mic input 1 in this case). Clicking a cross point box selects it, clicking it a second time sets the cross point, as indicated by a colored box. The dB level for set cross points is shown numerically in the box.

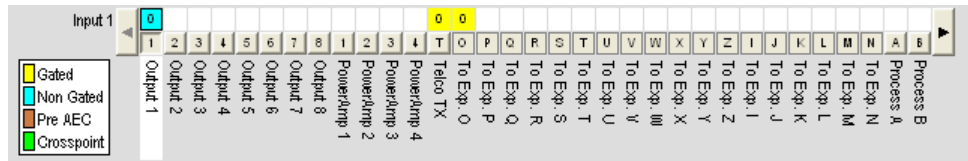

To adjust cross point gain/attenuation, right-click on a cross point box and select **Cross Point** from the shortcut menu.

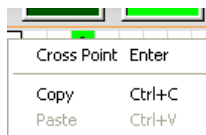

The **Cross Point Attenuation** slider appears. Move the slider or use the selector box to set the gain/attenuation level in dB. The range is from -60 to 12dB in .5dB increments. The default is 0dB. Note that the level to the nearest dB is displayed in the cross point for the channel on the Matrix.

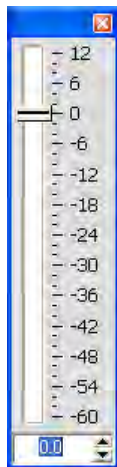

NOTE: Your changes are automatically saved when you close the slider.

Expanded Channel Routing Matrix

In the channel routing matrix, pressing the button underneath an **Output, Process, or Fader** cross point box displays the signal flow diagram and configuration controls for that channel. For example, clicking on **Output 5** displays the routing configuration for output channel 5 as shown below.

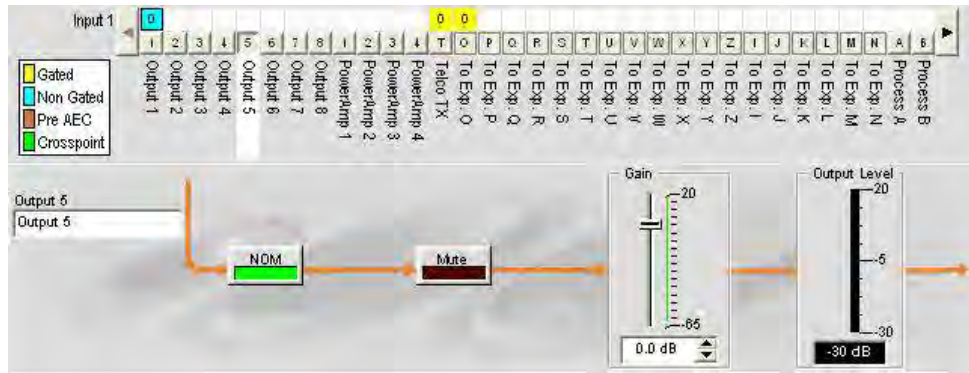

This display is identical to that shown in **Channel** when the output channel is selected in the **Tree View** pane. See **Output Settings** for more information.

You can change the channel **Label** (name) of the output channel in the label entry field; toggle **NOM** constant gain on or off; toggle **Mute** on or off; and use the **Gain slider** to set the gain level for the channel. The **Output Level** meter shows the level for the channel in real time as you make configuration changes.

NOTE: Changes to channel configuration settings made in the channel routing matrix apply globally to that channel. For example, changing the label (name) from **"Output 1"** to **"Ceiling Speakers"** changes the name of the output channel in the Tree View pane, and everywhere else the label appears in Console.

Creating Channel Objects

One of the most powerful features of Console is the ability to create Audio Devices and Channel Objects. Channel objects contain all settings for the channel at the time the object is created. After configuring an input using the Channel tab as described in this topic, you can save it into the database, and use drag and drop configuration to streamline configuration tasks.

To save an input channel configuration, right click in the Channel screen (anywhere above the channel routing matrix). From the shortcut menu that appears, select **Export Object** as shown below.

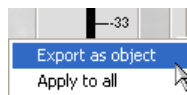

NOTE: You can apply the channel configurations for the current channel to all channels of the same type by selecting the **Apply to all** option. Use this option with caution because there is no way to undo the changes.

Enter an appropriate **Label** (name) in the entry field of **Export Object** dialog as shown below.

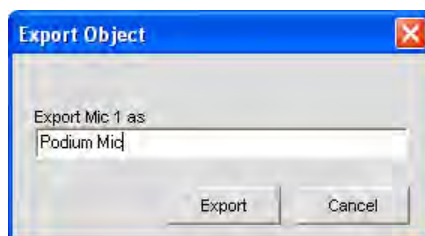

Click **Export** to save the configuration to the database, or **Cancel** to return to the Channel screen.

Console saves the object to the database and displays it in the Object Tree pane as shown below.

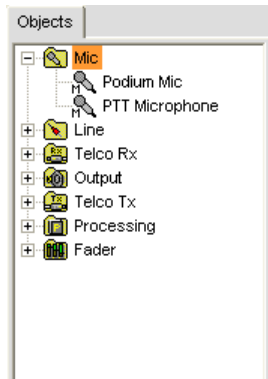

For more information on using audio devices and channel objects, refer to the *Table of Contents* for the following topics:

- **AV Devices**
- **Creating AV Devices**
- **Channel Objects**
- **Database Tab**
- **Drag & Drop Configuration**

Optimizing Input Gain Structure

Optimizing gain structure for input channels maximizes the signal-to-noise ratio for the channel and ensures optimal audio performance. Before configuring an input channel, ClearOne recommends that you review the *Optimizing Gain Structure* topic.

For additional information, refer to the *Table of Contents* for these related topics:

- **Channel Tab Overview**
- **AGC/ALC (Automatic Gain Control/Automatic Level Control)**
- **Mic Gating**
- **Gating Tab**
- **Matrix Tab**
- **Drag & Drop Configuration**
- **Database Tab**
- **Line Input Settings**
- **Output Settings**
- **Beamforming Microphone Configuration**

DIGITAL MICROPHONE PROCESSING

Digital Microphone Input Processing enables processing digital microphone audio connected through a CONNECT Dante or CONNECT CobraNet network bridge using the input stage instead of the audio on the analog inputs.

This disables the rear panel analog Mic/Line inputs and instead the uses the audio coming in from a CONNECT Dante or CobraNet. This allows microphones on a Dante or CobraNet network to be processed using AEC, Noise Suppression, AGC, Filtering, Gating, etc.

With this enabled, the analog output audio is mirrored to the digital outputs on the CONNECT Dante or CobraNet Bridge.

NOTE: In order to connect digital microphones to a CONVERGE Pro/SR the CONNECT Dante or CobraNet must be connected directly to the CONVERGE Pro/SR unit and the Expansion Bus **MUST** be connected **OUT** of the CONNECT and **IN** to the CONVERGE Pro/SR.

Digital Microphone Processing must first be enabled in **Site Properties**.



The number of digital microphones must then be selected in **Unit Properties** of the Converge Pro/SR. (The 840T is limited to a maximum of 4 channels.)

Digital Channels	880 Input/Output	840T Input/Output
0	-	-
2	7-8	3-4
4	5-8	1-4
8	1-8	n/a

When digital microphones are enabled a blue **D** is placed next to the corresponding Mic Channels, Output Channels, Matrix, and the enabled unit in the Site View pane.

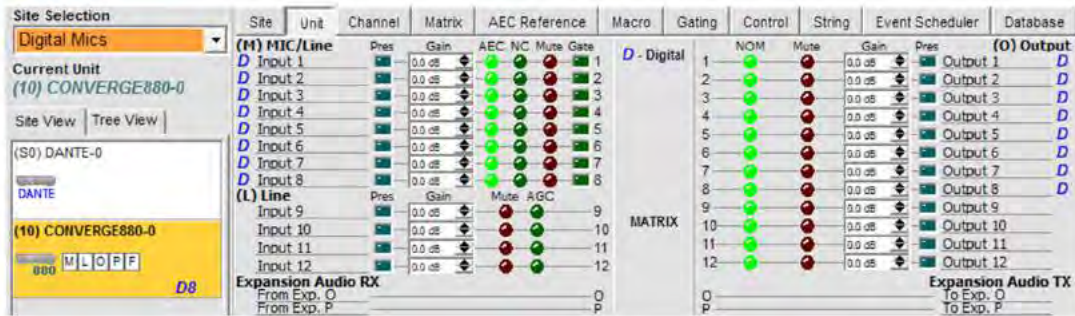

The microphone channels will no longer accept an analog input and the analog Phantom Power and Course Gain sections of the channel are removed. Everything else is processed digitally so nothing else in the Mic Channel is changed. These Mic Channels will now receive their input directly from the CobraNet or Dante networks.

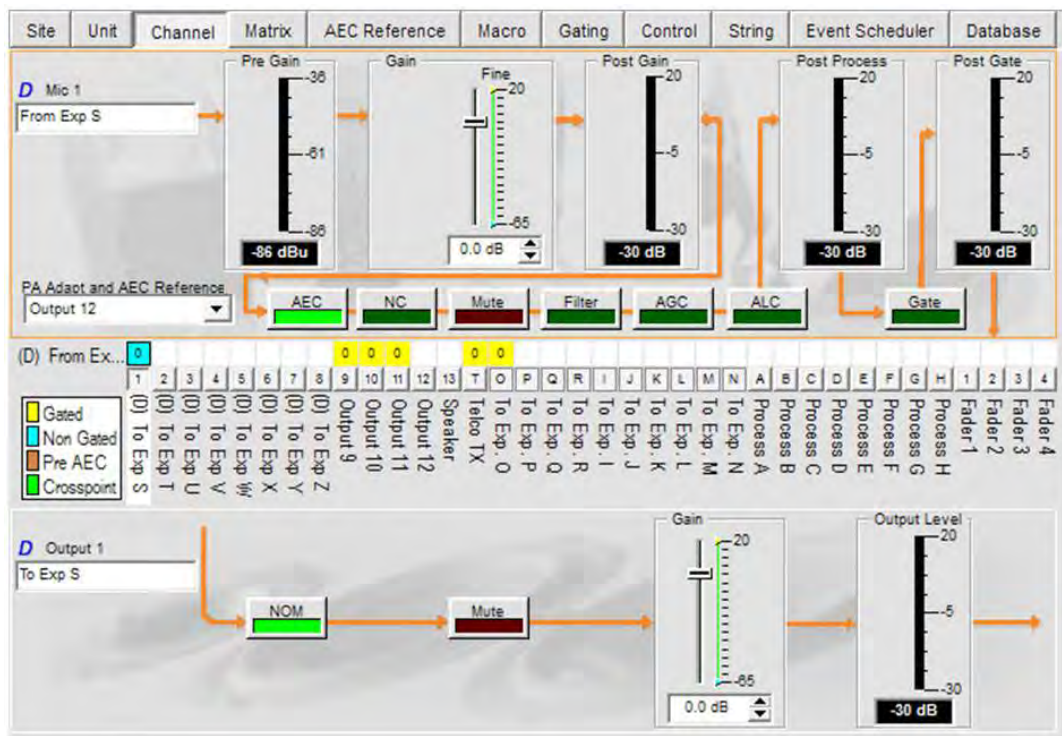

Expansion busses S - Z are now connected directly to the Input and Output Channels. They are not available site wide. The expansion busses S - Z are removed from the matrix and the labels are changed to show their position relative to the Inputs and Outputs. Once audio is routed on to a Digital Mic Channel, it can be routed anywhere else on the matrix just as though it were a regular channel and behaves just like a regular Mic Channel. The only difference is the source. The output channels are capable of analog audio and digital audio at the same time.

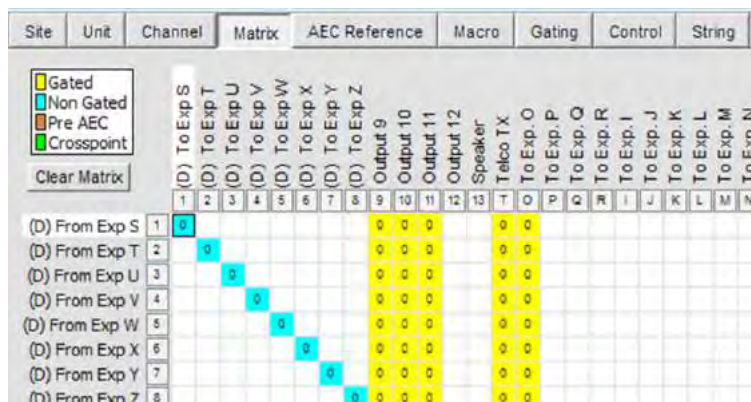

LINE INPUT SETTINGS

Line Input Settings enable you to customize line input channel settings. All settings for a given line input are available on the **Channel** screen.

Accessing Line Input Settings

With the **Channel** tab selected on the **Tab Bar**, select the desired line input channel on the **Tree View** tab in the **Site Pane**.

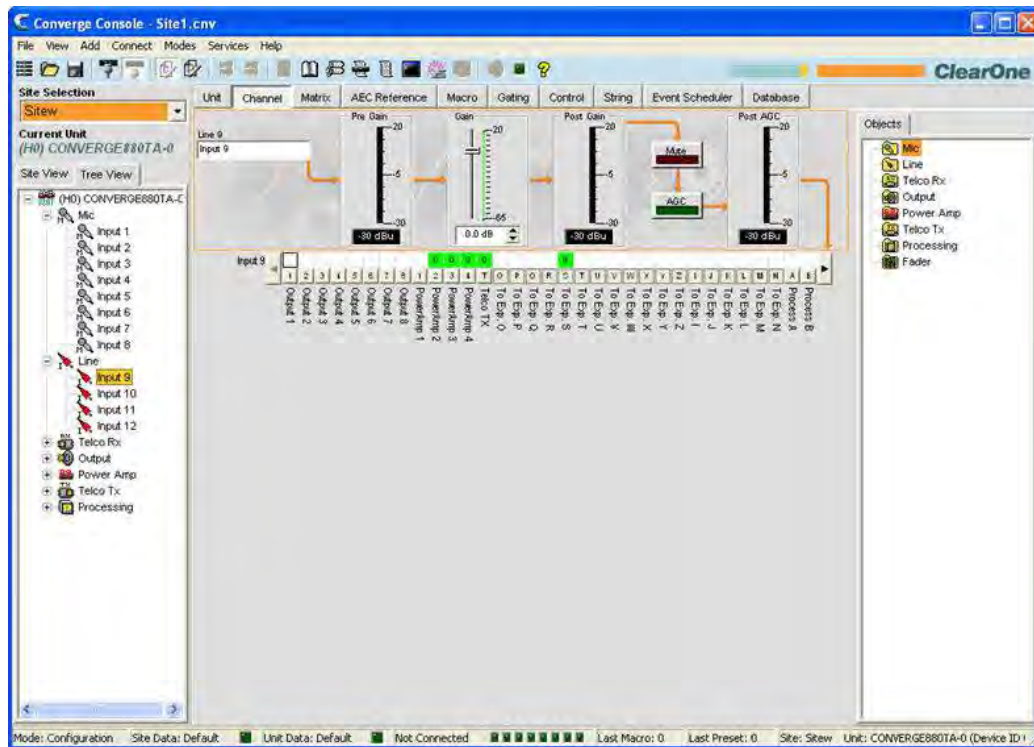

The **Center Pane** displays a signal processing diagram, meters, and configuration controls for selected line input channel as shown above. Note that the meters and configuration controls are shown at the appropriate point in the signal path.

The meters and configuration controls for line inputs are explained in the following sections.

Channel Label



Rename the channel by entering a name in the Label entry field (optional). Label changes are global, and appear throughout Console wherever the label is referenced.

Pre Gain Meter

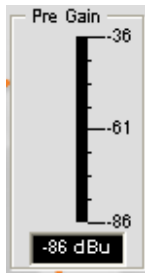

The **Pre Gain Meter** shows the line input level before gain adjustments.

NOTE: All meters in Console are peak-level meters.

Gain Slider

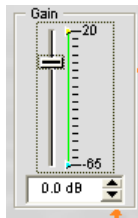

The **Gain Slider** adjusts the line input volume level. The **MIN/MAX** fine gain sliders are used to set minimum and maximum gain settings, and to report min/max gain settings via serial commands. You can also set the gain in .5dB increments using the **Up/Down** buttons, or enter a value directly in the field.

Post Gain Meter

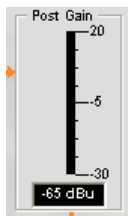

The **Post Gain Meter** shows the input level after gain adjustments.

Mute Button

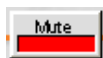

Clicking the **Mute** button toggles muting. The default is Off.

AGC (Automatic Gain Control) Button

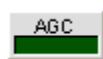

Clicking the **AGC (Automatic Gain Control)** button displays the **Channel Property Configuration** dialog for the selected input channel as shown below.

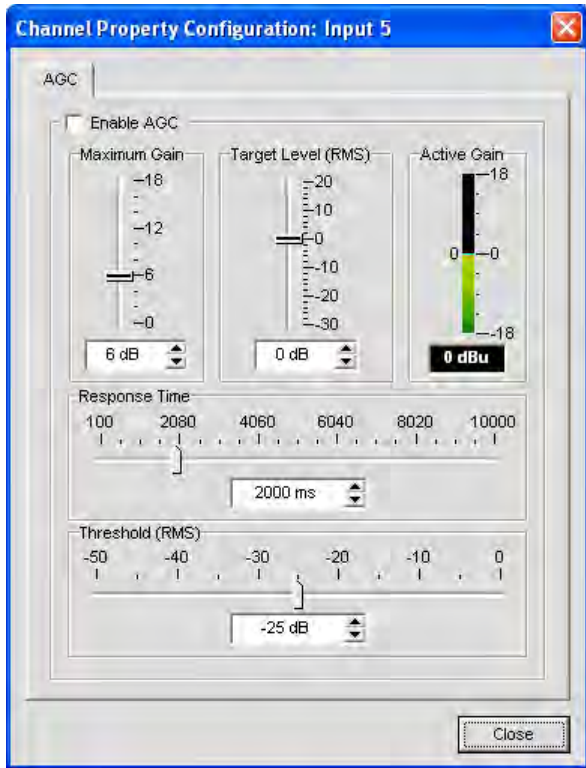

Select the **Enable AGC** checkbox to enable AGC, or deselect it to disable AGC. For AGC configuration details, see **AGC Configuration Settings**.

Channel Routing Matrix: Line Inputs

The channel routing matrix shows the associated matrix row and audio routing configuration for the selected input channel (line input 5 in this case). Clicking a cross point box selects it, clicking it a second time sets the cross point, as indicated by a green box. The dB level for set cross points is shown numerically in the box.

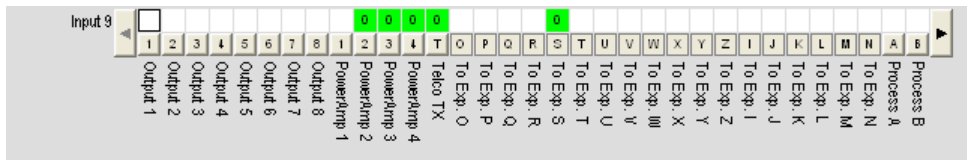

To adjust cross point gain/attenuation, right-click on a cross point box and select **Cross Point** from the shortcut menu.

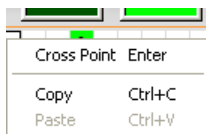

The **Cross Point Attenuation** slider appears. Move the slider or use the selector box to set the gain/attenuation level in dB. The range is from -60 to 12dB in .5dB increments. The default is 0dB.

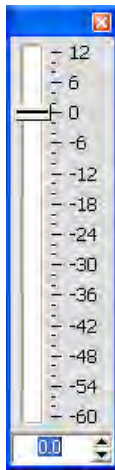

NOTE: Your changes are automatically saved when you close the slider.

Channel Routing Matrix: Outputs, Processing, Faders

In the channel routing matrix, pressing the button underneath an **Output, Process, or Fader** cross point box displays the signal flow diagram and configuration controls for that channel. For example, clicking on **Output 5** displays the routing configuration for output channel 5 as shown below.

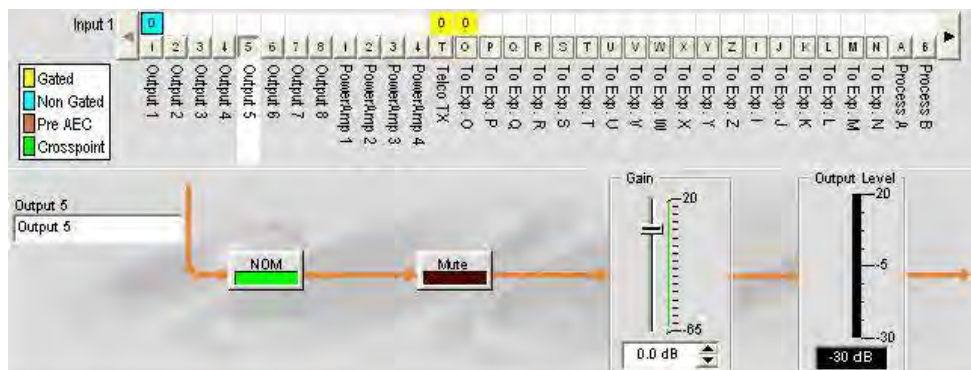

This display is identical to that shown in **Channel** when the output channel is selected in the **Tree View** pane. See **Output Settings** for more information.

You can change the channel **Label** (name) of the output channel in the label entry field; toggle **NOM** constant gain on or off; toggle **Mute** on or off; and use the **Gain slider** to set the gain level for the channel. The **Output Level** meter shows the level for the channel in real time as you make configuration changes.

NOTE: Changes to configuration settings made in the channel routing matrix apply globally to that channel. For example, changing the label (name) from "Output 1" to "Ceiling Speakers" changes the name of the output channel in the Tree View pane, and everywhere else the label appears in Console.

Creating Channel Objects

One of the most powerful features of Console is the ability to create Channel Objects. Channel objects capture all settings for the channel at the time the object is created. After configuring an input using the Channel tab as described in this topic, you can save it into the Database, and use drag and drop configuration to streamline configuration tasks.

To save an input channel configuration, right click in the **Channel** screen (anywhere above the channel routing matrix). From the shortcut menu that appears, select **Export Object** as shown below.

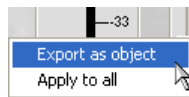

NOTE: You can apply the channel configurations for the current channel to all channels of the same type by selecting the **Apply to all** option. Use this option with caution because there is no way to undo the changes.

Enter an appropriate **Label** (name) in the entry field of **Export Object** dialog as shown below.



Click **Export** to save the configuration to the database, or **Cancel** to return to the Channel screen.

Console saves the object to the database and displays it in the **Object Tree** as shown below.

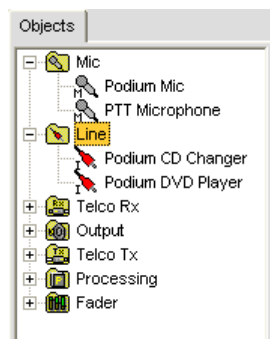

Optimizing Input Gain Structure

Optimizing gain structure for input channels maximizes the signal-to-noise ratio for the channel and ensures optimal audio performance. Before configuring an input channel, ClearOne recommends that you review the *Optimizing Gain Structure* topic.

For more information, refer to the *Table of Contents* for these related topics:

- **Channel Tab Overview**
- **AGC/ALC (Automatic Gain Control/Automatic Level Control)**
- **Mic Gating**
- **Gating Tab**
- **Matrix Tab**
- **Drag & Drop Configuration**
- **Database Tab**
- **Mic Input Settings**
- **Output Settings**

TELCO/VOIP RX SETTINGS

Telco/VoIP Rx Settings enable you to customize telephone receive channel settings using the **Channel** tab.

Accessing Telco/VoIP Rx Settings

With the **Channel** tab selected on the **Tab Bar**, select the **Telco/VoIP Rx** channel on the **Tree View** tab in the **Site** Pane.

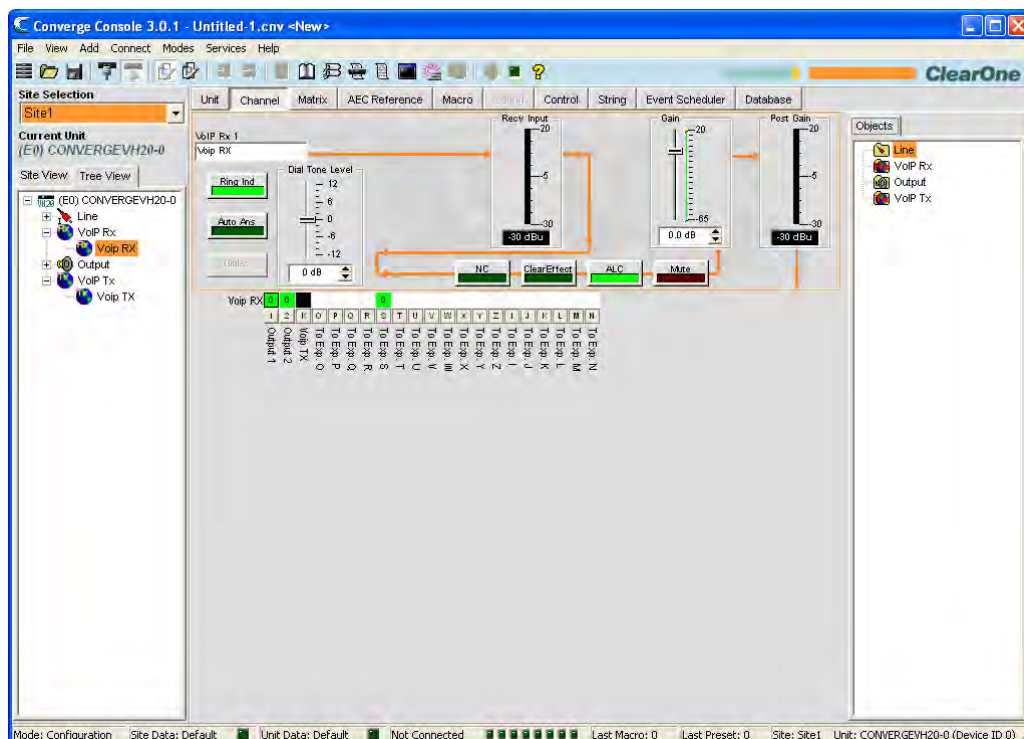
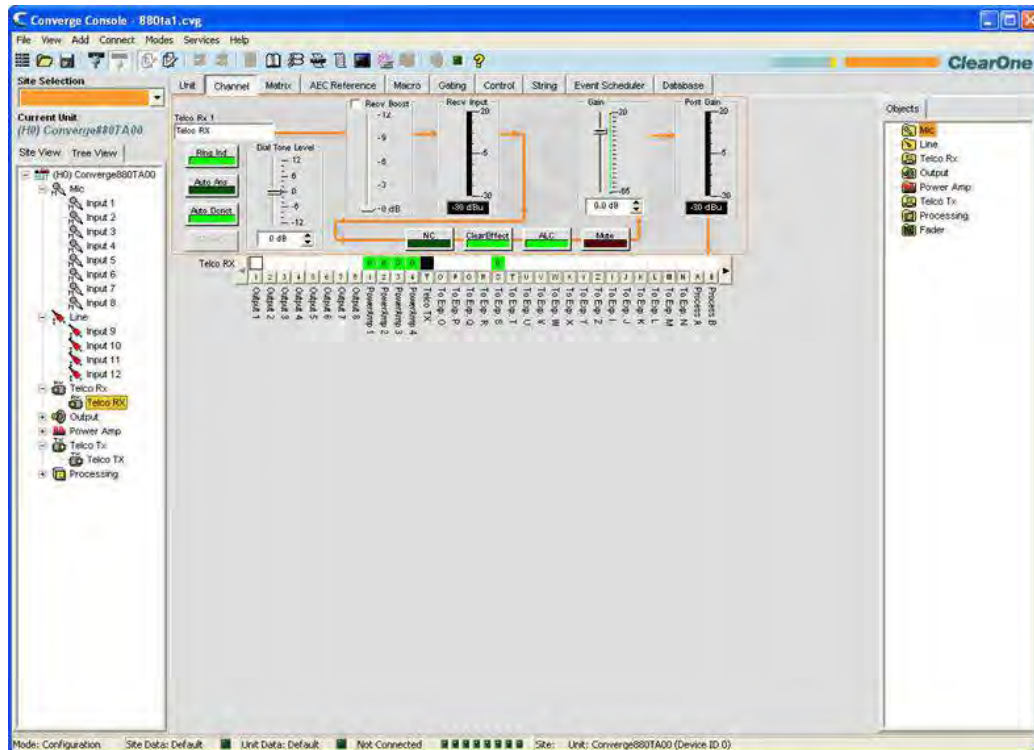

As shown above, the center pane displays a signal flow diagram for the Telco/VoIP Rx channel, real-time peak-level meters, as well as a channel routing matrix that displays the audio routing configuration for the channel. Note that the meters and configuration controls are shown at the appropriate point in the signal path.

The following sections describe how to use these controls (in order from left-to-right and top-to-bottom as they appear in the signal flow) to configure the Telco receive channel settings for your installation.

Channel Label

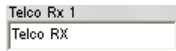

Rename the channel by entering a name in the **Label** entry field (optional). Labels are shown throughout Console wherever the channel is referenced.

Channel Configuration Buttons

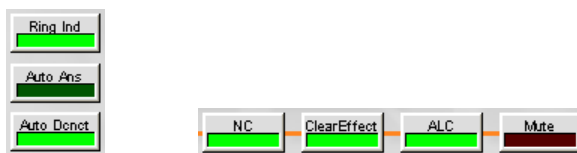

The Channel Configuration Buttons enable you to configure settings for the Telco/VoIP Rx channel. With the exception of the Mute, ClearEffect™, and ALC buttons, which toggle their respective functions and have no user-configurable settings, clicking a channel configuration button displays the Channel Property Configuration window as shown below.



The window contains three tabs: **NC (Noise Cancellation)**, **Telco Settings**, and **Telco Meters**, which are described in the following sections.

NC (Noise Cancellation) Tab

Select the **Enable Noise Canceller** checkbox to enable NC for the channel. Adjust the **Cancellation Depth** slider to the dB setting which provides the best combination of low noise and maximum speech clarity. The attenuation depth can be set in 1dB increments from 6dB to 15dB. The default is 6dB. The default for NC is off.

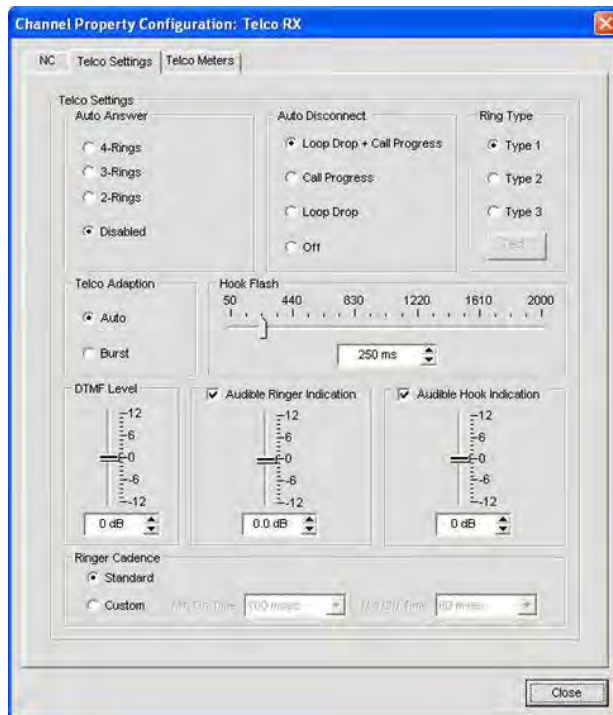

You can use noise cancellation on all types of input channels. See *NC (Noise Cancellation)* for more information.

Telco Settings Tab

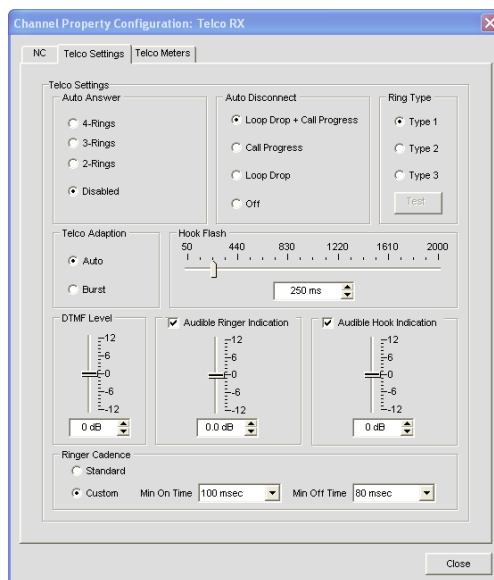

Settings available on the **Telco Settings Tab** include:

Auto Answer: Set the number of rings before the unit connects an incoming call (or disable the function). The default is Disabled.

Auto-Disconnect: Select the auto disconnect mode to control when the unit disconnects a connected call. Modes include **Loop Drop + Call Progress**, **Call Progress**, and **Loop Drop**, and **Off**. The default is Loop Drop + Call Progress. **(Not used in VoIP Settings)**

Ring Type: Select from three different ring tones (**Type 1**, **Type 2**, **Type 3**). To test a particular tone, click **Test** after you have selected the tone.

Note: VH20 Units have five selectable ring types.

Telco Adaptation: Some applications require the unit to adapt to line conditions using a white-noise burst (**Noise**) rather than automatically (Auto). The default is **Auto**. **(Not used in VoIP Settings)**

Hook Flash: Sends a momentary interruption in the line seizure, allowing activation of options such as 3-way calling, call waiting, and call hold. This feature is dependent on the services offered by your telephone company. You can set the duration of the hook flash using the slider or the selector box. Range is 50ms to 2 seconds in 10ms steps. The default is 250ms.

DTMF Level: This feature allows you to adjust the DTMF tone level in relationship to the participant audio level in the room. The level can be adjusted in 1dB steps from a nominal level of 0dB to plus or minus 12dB in 1dB increments. The default is 0dB.

Audible Ring Indication: When this feature is enabled, an audible ring is heard for incoming calls. The level adjustment allows you to customize the level in relationship to the participant audio level in the room. The level can be adjusted in 1dB steps from a nominal level 0 (default) to plus or minus 12dB in 1dB increments. The default is 0dB.

Audible Hook Indication: When the unit goes off hook (connects) a beep is injected into the receive channel and transmit channel of the unit. When the unit goes on hook (disconnects), a series of two beeps is injected into the receive channel to indicate that the call has been dropped.

Ringer Cadence: (Not used in VoIP Settings)

- **Standard:** Uses the cadence specified in the Country Code to detect the standard ring cadence per country.
- **Custom:** Set for distinctive ring cadences. When custom is set, the **Min On** and **Min Off** times must be selected from their respective drop-down boxes. PBX's can have distinctive ring cadences that are not country specific. These times are the minimum values the ring cadence must be for the unit to detect the ring. If the ring cadence signal provided by the PBX is greater than the custom settings, the unit will detect the ring.

Telco Meters Tab (Not available on the VH20)

The Telco Meters tab displays a round-trip signal flow diagram for the selected Telco Rx, as well as real-time level meters for the signal at each stage of processing. The settings on this tab cannot be modified.

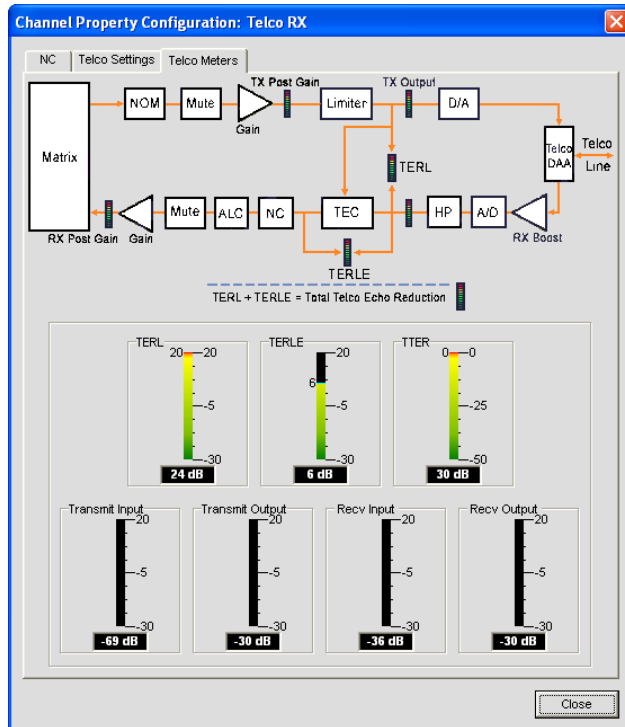

NOTE: When you click the **Close** button (bottom right corner of screen), or close the window manually, any changes you make in the tabs of the **Channel Property Configuration: Telco RX** screen are automatically saved.

The Telco meters include:

- **Telephone Echo Return Loss (TERL):** This meter shows the amount of echo loss from the telephone line to the unit.
- **Telephone Echo Return Loss Enhancement (TERLE):** This meter shows the enhancement added by the telephone hybrid to reduce echo below the audible level.
- **Total Telephone Echo Reduction (TTER):** This meter shows the sum of TERL and TERLE.
- **Transmit Input:** This meter shows the audio level input from the matrix to the telephone line.
- **Transmit Output:** This meter shows the transmit audio level output to the telephone line.
- **Receive Input:** This meter shows the audio level input received from the telephone line.
- **Receive Output:** This meter shows the receive audio level output to the matrix.

Dialer Button



The **Dialer** button opens the telephone dialer, allowing you to place conference calls.



See the *Dialer* topic for more information on using the dialer and its features.

Dial Tone Level Slider

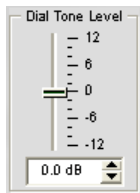

The **Dial Tone Level** slider allows you to set dial tone gain using the slider or selector box. The default is zero. Range is -12dB to 12dB in 1dB increments.

Recv Boost Slider

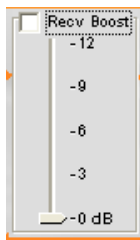

The **Receive Boost** slider allows you to set the gain for the incoming Telco/VoIP Rx signal. This is typically used for low-level telephone lines, allowing the signal to be boosted to an acceptable level of performance. To use **Receive Boost**, check the **Recv Boost** check box, then move the slider to the desired gain settings.

Recv Boost adds up to 12dB of gain to the signal (adjustable in 3dB increments from 0dB to 12dB). The default is Off.

Recv Input Meter

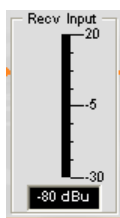

The **Receive Input** meter displays the dB level of the incoming Telco signal prior to any signal processing.

NOTE: All meters in Console are peak-level meters.

NC Button



Clicking the **Noise Cancellation** button opens the **Channel Property Configuration: Telco/VoIP RX** window with the **NC** tab selected, allowing you to configure noise cancellation settings.

To use noise cancellation, click **Enable Noise Canceller**, then adjust the **Cancellation Depth** to the setting which provides the best combination of low noise and maximum speech clarity for your installation. The attenuation depth can be set in 1dB increments from 6dB to 15dB. The default is 6dB. The noise canceller default is Off.

ClearEffect™ Button



To reduce bandwidth requirements, telephone lines limit audio bandwidth to a range of 300Hz–3.3kHz. ClearEffect™ enhances the incoming signal from a telephone line to emulate wideband audio by adding high and low frequencies to the audio signal.

Click the **ClearEffect™** button to toggle this feature on and off. The default is On.

ALC Button



Clicking the **Automatic Level Control** button toggles ALC on and off. ALC provides auto-leveling for all conference call participants on the Telco/VoIP Rx line, keeping soft and loud participants at a consistent level. The default is Off. See AGC/ALC for additional information.

NOM Button



Maintains a constant output level by automatically adjusting gain levels based on the number of mics gated on and routed to the selected output channel. NOM reduces the output level proportionally by 3dB for every doubling in the number of open mics. When using NOM over the expansion bus, only I – R Buses support passing NOM information. The default is On.

Mute Button



Clicking the **Mute** button toggles muting for the Telco receive channel. The default is Off.

Gain Slider

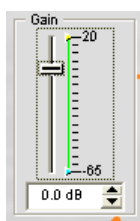

The **Gain** slider changes the gain for the Telco receive channel from nominal 0. To change the value, use the slider or the selector box. Range is from -65 to +20dB in .5dB increments. The default is 0dB.

Min/Max Limits

Use the yellow and green upper and lower limit arrows on the **Gain Scale** in the **Gain** section of the screen to set minimum and maximum gain level limits. These limits only apply when using relative gain commands; absolute gain commands can exceed the min and max limits. Min/Max limits apply to all serially connected control devices and prevent users from adjusting levels beyond the specified levels.

Post-Gain Meter

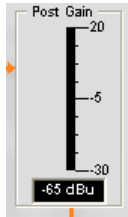

The **Post Gain** level meter displays the post-gain signal level in dB.

Channel Routing Matrix

The channel routing matrix section of the **Channel** screen shows the associated matrix row and audio routing configuration for the selected input channel (Telco/VoIP Rx in this case). Clicking a cross point box selects it, clicking it a second time sets the cross point, as indicated by a green box. The dB level for set cross points is shown numerically in the box.

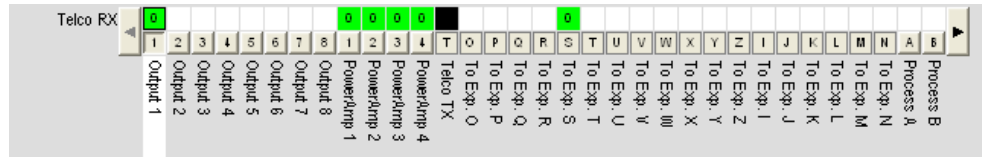

For Telco/VoIP Rx channels, **Outputs 5-8, Speaker, and To Exp. Bus S** are selected as cross points by default. You can click directly on any cross point box in the top row to a cross point (routing path), or leave it blank, as required for your installation.

To adjust cross point gain/attenuation, right-click on a cross point box and select **Cross Point** from the shortcut menu.

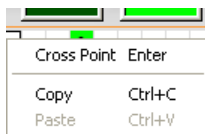

The **Cross Point Attenuation** slider appears. Move the slider or use the selector box to set the gain/attenuation level in dB. The range is from -60 to 12dB in .5dB increments. The default is 0dB.

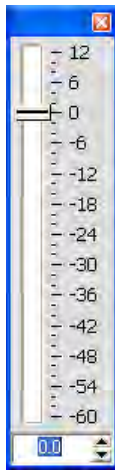

NOTE: Your changes are automatically saved when you close the slider.

In the channel routing matrix, pressing the button underneath an **Output**, **Process**, or **Fader** cross point box displays the signal flow diagram and configuration controls for that output channel as shown below.

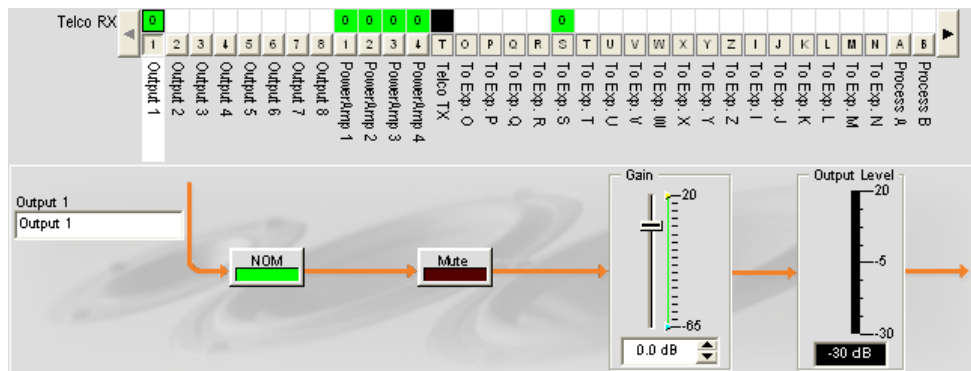

This display is identical to that shown in **Channel** when the output channel is selected in the **Tree View** pane. See **Output Settings** for more information.

You can change the label (name) of the output channel in the **Output** entry box, toggle the **NOM** button to turn constant gain mode on or off, toggle the **Mute** button to mute or un-mute the channel, and use the **Gain** slider to set the gain level for the channel. The **Output Level** meter shows the level for the channel in real time.

NOTE: Changes to configuration settings made in the channel routing matrix apply globally to the output, processing, or fader channel. For example, changing the label (name) from **“Output 1”** to **“Ceiling Speakers”** changes the name of the channel in the **Tree View** pane, and everywhere else the label appears in **Console**.

Creating Channel Objects

One of the most powerful features of **Console** is the ability to create Channel Objects. Channel objects capture all settings for the channel at the time the object is created. After configuring an input using the **Channel** tab as described in this topic, you can save it into the **Database**, and use drag and drop configuration to streamline configuration tasks.

To save a **Telco/VoIP Rx** channel configuration, right click in the **Channel** screen (anywhere above the channel routing matrix). From the shortcut menu that appears, select **Export Object** as shown below.

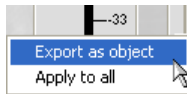

Enter an appropriate **Label** (name) in the entry field of **Export Object** dialog as shown below.

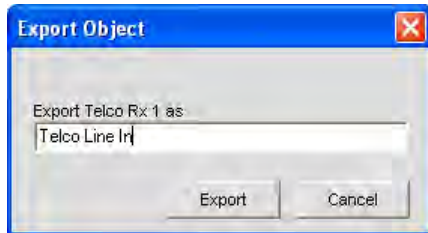

Click **Export** to save the configuration to the database, or **Cancel** to return to the Channel screen

Console saves the object to the database and displays it in the **Object Tree** as shown below.

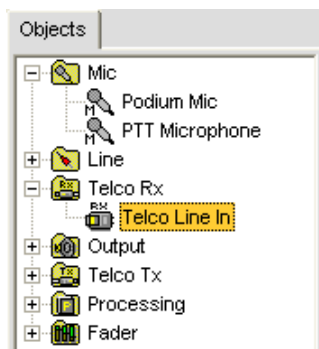

For more information on using audio devices and channel objects, refer to the *Table of Contents* for these topics:

- **AV Devices**
- **Creating AV Devices**
- **Channel Objects**
- **Database Tab**
- **Drag & Drop Configuration**

Optimizing Input Gain Structure

Optimizing gain structure for input channels maximizes the signal-to-noise ratio for the channel and ensures optimal audio performance. When configuring the Telco/VoIP Rx channel, ClearOne recommends that you follow the procedures outlined in the *Optimizing Gain Structure* topic.

For more information, refer to the *Table of Contents* for these related topics:

- **Channel Tab Overview**
- **NC (Noise Cancellation)**
- **Mic Gating**
- **Gating Tab**
- **AGC/ALC (Automatic Gain Control/Automatic Level Control)**
- **Label Editor**
- **Output Settings**
- **Telco/VoIP Tx Settings**

OUTPUT SETTINGS

Output Settings enable you to customize output channel settings. All settings for a given output are available on the **Channel** screen.

Accessing Output Settings

With the **Channel** tab selected on the **Tab Bar**, select the desired output channel on the **Tree View** tab in the **Site Pane**.

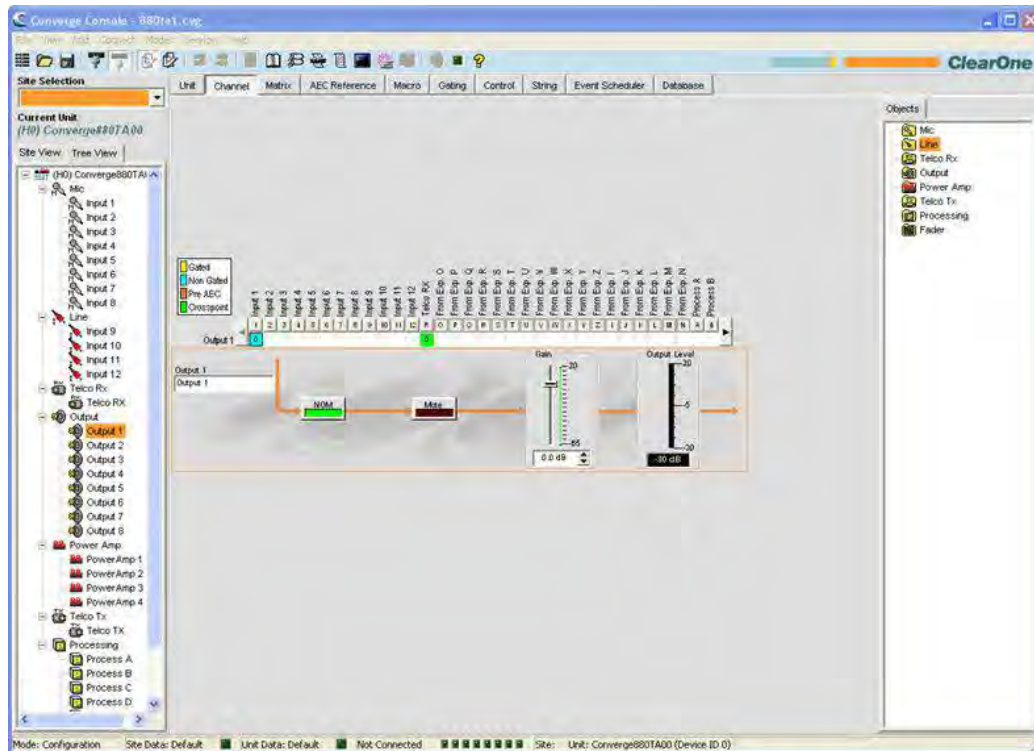

The center pane of the screen displays a signal flow diagram, a real-time **Output Level Gain** meter, as well as the channel routing matrix, which shows the audio routing configuration for the selected output channel.

The following sections describe how to use output channel configuration controls.

Channel Label



Rename the channel by entering a name in the **Label** entry field (optional). Label changes are global, and appear throughout Console wherever the label is referenced.

NOM (Number of Open Mics/Constant Level)

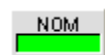

Maintains a constant output level by automatically adjusting gain levels based on the number of mics gated on and routed to the selected output channel. NOM reduces the output level proportionally by 3dB for every doubling in the number of open mics. When using NOM over the expansion bus, only I – R Buses support passing NOM information. The default is On.

Mute Button



Clicking the **Mute** button toggles muting. The default is Off.

Gain Slider

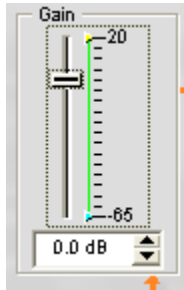

The **Gain** slider adjusts the output gain level. To change the value, use the slider or selector box. Range is from -65 to +20dB in .5dB increments. The default is 0dB.

Min/Max Limits

Use the yellow and green upper and lower limit arrows on the **Gain Scale** in the **Gain** section of the screen to set minimum and maximum gain level limits. These limits only apply when using relative gain commands; absolute gain commands can exceed the min and max limits. Min/Max limits apply to all serially connected control devices and prevent users from adjusting levels beyond the specified levels.

Output Level Meter

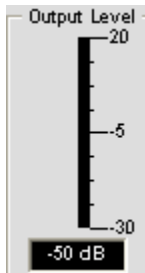

Shows the signal level in dB when a signal is present.

Channel Routing Matrix: Outputs

The channel routing matrix shows the matrix row and audio routing configuration for the selected channel (Output 1 in this case). Clicking a cross point box selects it, clicking it a second time sets the cross point, as indicated by a green box. The dB level for set cross points is shown numerically in the box.

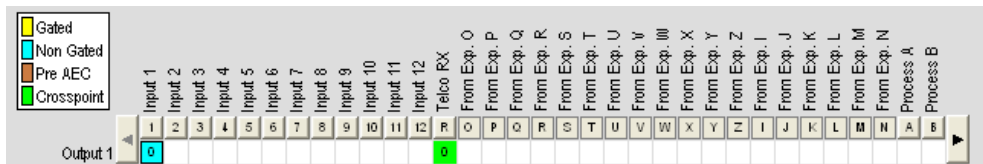

You can click directly on any cross point box in the top row to set a parameter as cross point, or leave it blank, as required for your installation. To adjust cross point gain/attenuation, right-click on a cross point box and select **Cross Point** from the shortcut menu.

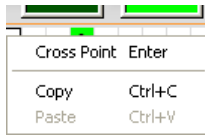

The **Cross Point Attenuation** slider appears. Move the slider or use the selector box to set the gain/attenuation level in dB. The range is from -60 to 12dB in .5dB increments. The default is 0dB.

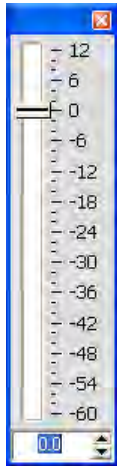

NOTE: Your changes are automatically saved when you close the slider.

Channel Routing Matrix: Inputs, Processing, Faders

In the channel routing matrix, pressing the button above an **Input**, **Process**, or **Fader** cross point box displays the signal flow diagram and configuration controls for that channel.

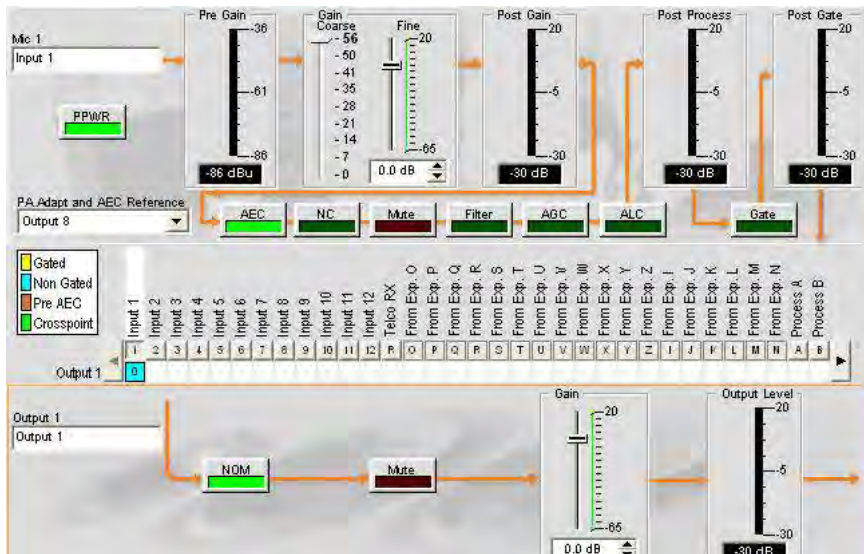

This display is identical to that shown in Channel when the channel is selected in the Tree View pane. See *Mic Input Settings*, *Line Input Settings*, *Processing Settings*, and *Fader Settings* for more information.

You can change the label (name) of the channel in the Output entry box, toggle the NOM button to turn constant gain mode on or off, toggle the Mute button to mute or un-mute the channel, and use the Gain slider to set the gain level for the channel. The Output Level meter shows the level for the channel in real time.

NOTE: Changes to configuration settings made in the channel routing matrix apply globally to that channel. For example, changing the label (name) from “**Input 1**” to “**Ceiling Mic**” changes the name of the channel in the Tree View pane, and everywhere else the label appears in Console.

Creating Channel Objects

One of the most powerful features of Console is the ability to create Channel Objects. Channel objects capture all settings for the channel at the time the object is created. After configuring an input using the Channel tab as described in this topic, you can save it into the Database, and use drag and drop configuration to streamline configuration tasks.

To save an input channel configuration, right click in the **Channel** screen (anywhere above the channel routing matrix). From the shortcut menu that appears, select **Export Object** as shown below.

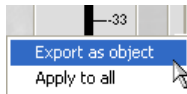

NOTE: You can apply the channel configurations for the current channel to all channels of the same type by selecting the **Apply to all** option. Use this option with caution because there is no way to undo the changes.

Enter an appropriate **Label** (name) in the entry field of **Export Object** dialog as shown below.

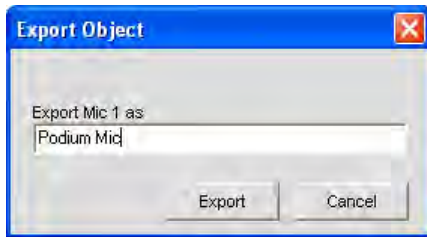

Click **Export** to save the configuration to the database, or **Cancel** to return to the Channel screen.

Console saves the object to the database and displays it in the **Object Tree** as shown below.



For more information on using audio devices and channel objects, see the *Table of Contents* for the following topics:

- **AV Devices**
- **Creating AV Devices**
- **Channel Objects**
- **Database Tab**
- **Drag & Drop Configuration**

TELCO/VOIP TX SETTINGS

Telco/VoIP Tx Settings enable you to customize telephone transmit channel settings using the **Channel** screen.

Accessing Telco/VoIP Tx Settings

With the **Channel** tab selected on the **Tab Bar**, select the **Telco/VoIP Tx** channel on the **Tree View** tab in the **Site** Pane.

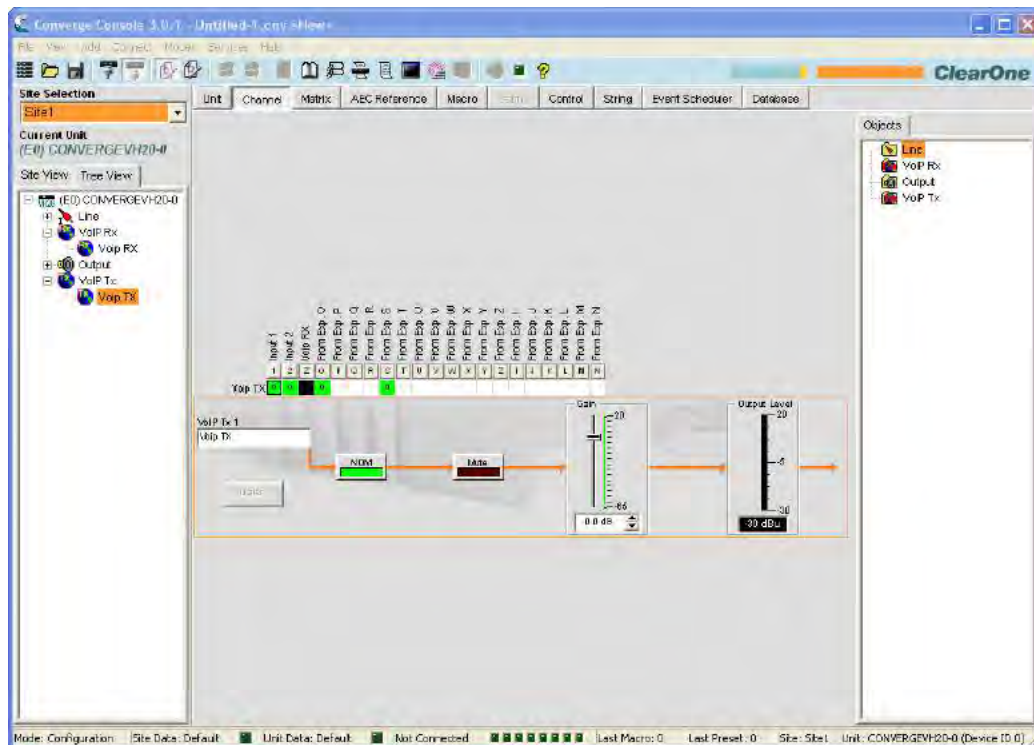
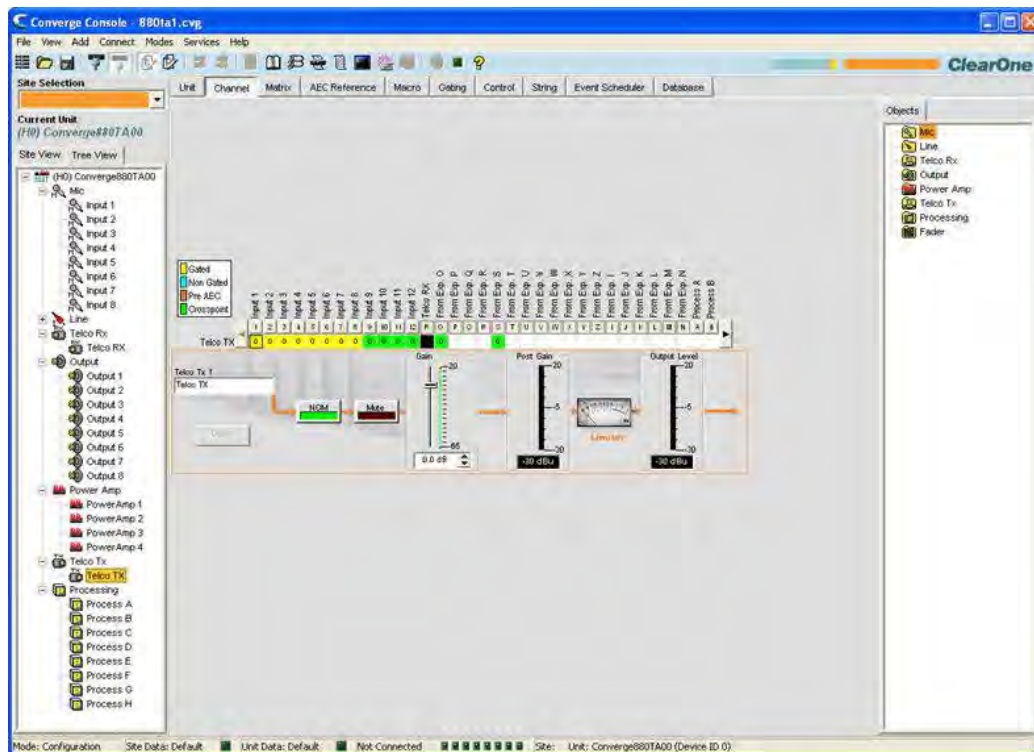

As shown above, the **Center Pane** displays a signal flow diagram for the Telco/VoIP Tx channel, real-time peak-level meters, as well as the channel routing matrix, which shows the audio routing configuration for the channel. Configuration settings for the Telco/VoIP Tx channel are displayed as controls (buttons, sliders, etc.) which are located at the appropriate stage in the signal flow.

The following sections describe how to use these controls to configure Telco transmit settings for your installation.

Channel Label



Rename the channel by entering a name in the **Label** entry field (optional). Label changes are global, and appear throughout Console wherever the label is referenced.

Dialer Button



The **Dialer** button opens the telephone dialer (shown below), allowing you to place calls to establish a conference call with a remote location.



See **Dialer** for more information on using the dialer and its features .

NOM (Number of Open Mics/Constant Level)



Maintains a constant output level by automatically adjusting gain levels based on the number of mics gated on and routed to the selected output channel. NOM reduces the output level proportionally by 3dB for every doubling in the number of open mics. When using NOM over the expansion bus, only I – R Buses support passing NOM information. The default is On.

Mute Button



Clicking the **Mute** button toggles muting. The default is Off.

Gain Slider

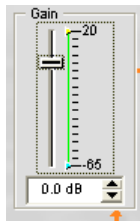

The **Gain** slider adjusts the output gain level. To change the value, use the slider or selector box. Range is from -65 to +20dB in .5dB increments. The default is 0dB.

Min/Max Limits

Use the yellow and green upper and lower limit arrows on the **Gain Scale** in the **Gain** section of the screen to set minimum and maximum gain level limits. These limits only apply when using relative gain commands; absolute gain commands can exceed the min and max limits. Min/Max limits apply to all serially connected control devices and prevent users from adjusting levels beyond the min/max levels.

Post-Gain Meter

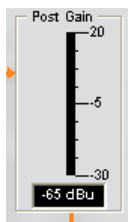

The **Post Gain** level meter displays the post-gain signal level in dB.

Limiter



The **Limiter** limits the output level to the Telco side to comply with Telco system requirements. Note that the meter is only a graphic; it does not show limiter activity. **(Not used in VoIP settings)**

Output Level Meter

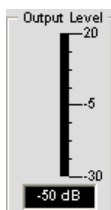

Shows the signal level in dB when a signal is present.

Channel Routing Matrix: Telco/VoIP TX

The graphic below shows the Telco/VoIP Tx channel routing matrix.

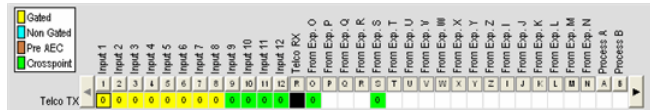

All inputs from **Exp. O**, and from **Exp. S** are selected as cross points and the first four inputs are gated by default. Clicking a cross point box selects it, clicking it a second time sets the cross point, as indicated by a colored box. The dB level for set cross points is shown numerically in the box.

To adjust cross point gain/attenuation, right-click on a cross point box and select **Cross Point** from the shortcut menu.

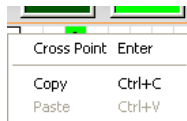

The **Cross Point Attenuation** slider appears. Move the slider or use the selector box to set the gain/attenuation level in dB. The range is from -60 to 12dB in .5dB increments. The default is 0dB.

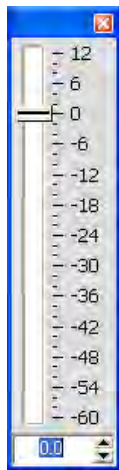

NOTE: Your changes are automatically saved when you close the slider.

Channel Routing Matrix: Inputs, Processing, Faders

In the channel routing matrix, pressing the button above an **Input**, **Process**, or **Fader** cross point box displays the signal flow diagram and configuration controls for the channel as shown below.

The screenshot displays the configuration interface for a channel named 'Mic 1'. The interface is divided into several sections:

- Input Section:** Shows 'Mic 1' and 'Input 1' with a 'PPWR' meter. Below are sliders for 'Pre Gain' (ranging from -86 to -36 dBu), 'Gain Coarse' (ranging from -56 to -0 dB), and 'Fine' (ranging from -65 to 20 dB).
- Processing Section:** Includes sliders for 'Post Gain' (ranging from -30 to 20 dB), 'Post Process' (ranging from -30 to 20 dB), and 'Post Gate' (ranging from -30 to 20 dB). Below these are buttons for 'AEC', 'NC', 'Mute', 'Filter', 'AGC', 'ALC', and 'Gate'.
- Routing Matrix:** A grid showing connections between inputs and outputs. The 'Telco TX' row shows connections to 'Input 1' through 'Input 12' (all green), 'Telco RX' (green), and 'From Exp. O' through 'From Exp. S' (all green). The 'Process A' and 'Process B' columns are also shown.
- Output Section:** Shows 'Telco Tx 1' and 'Telco TX' with a 'Dialer' button. Below are buttons for 'NOM' and 'Mute', a 'Gain' slider (ranging from -65 to 20 dB), a 'Post Gain' slider (ranging from -30 to 20 dB), a 'Limit' meter, and an 'Output Level' meter (ranging from -30 to 20 dB).

This display is identical to that shown in **Channel** when the channel is selected in the **Tree View** pane. See **Mic Input Settings**, **Line Input Settings**, **Processing Settings**, and **Fader Settings** for more information.

You can change the label (name) of the channel in the **Telco/VoIP Tx** entry box, toggle the **NOM** button to turn constant gain mode on or off, toggle the **Mute** button to mute or un-mute the channel, and use the **Gain** slider to set the gain level for the channel. The **Output Level** meter shows the level for the channel in real time.

NOTE: Changes to channel configuration settings made in the channel routing matrix apply globally to that channel. For example, changing the label (name) from "Input 1" to "Podium Mic" in the Mic 1 entry box changes the name of the channel in the Tree View pane, and everywhere else the label appears in Console.

Creating Channel Objects

One of the most powerful features of Console is the ability to create Channel Objects. Channel objects capture all settings for the channel at the time the object is created. After configuring an input using the Channel tab as described in this topic, you can save it into the Database, and use drag and drop configuration to streamline configuration tasks.

To save an input channel configuration, right click in the **Channel** screen (anywhere above the channel routing matrix). From the menu that appears, select **Export Object** as shown below.

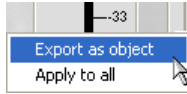

NOTE: You can apply the channel configurations for the current channel to all channels of the same type by selecting the **Apply to all** option. Use this option with caution because there is no way to undo the changes.

Enter an appropriate **Label** (name) in the entry field of **Export Object** dialog as shown below.

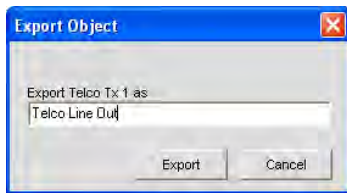

Click **Export** to save the configuration to the database, or **Cancel** to return to the Channel screen.

Console saves the object to the database and displays it in the **Object Tree** as shown below.

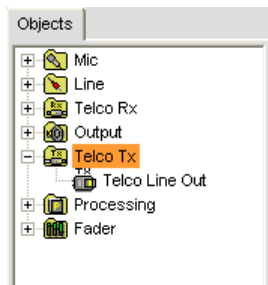

For more information on using audio devices and channel objects, see the following topics:

- **AV Devices**
- **Creating AV Devices**
- **Channel Objects**
- **Database Tab**
- **Drag & Drop Configuration**

Optimizing Output Gain Structure

Optimizing gain structure for output channels ensures optimal audio performance. When initially configuring output channels, ClearOne recommends that you follow the procedures outlined in the *Optimizing Gain Structure* topic.

For more information, refer to the *Table of Contents* for these related topics:

- **Channel Tab Overview**
- **Mic Gating**
- **Gating Tab**
- **Line Input Settings**
- **Mic Input Settings**
- **Processing Settings**
- **Fader Settings**
- **Telco/VoIP Rx Settings**
- **Optimizing Gain Structure**

PROCESSING SETTINGS

Processing Settings enable you to configure filters, delay, compression, and gain to create precise audio configurations for any venue. There are four processing blocks available for the 840T (A-D), and eight for the 880, 880T, 880TA, 8i, SR 1212 (A-H) and SR 1212A (A-H).

Accessing Processing Settings

With the **Channel** tab selected on the **Tab Bar**, select the desired processing block on the **Tree View** tab in the **Site Pane**.

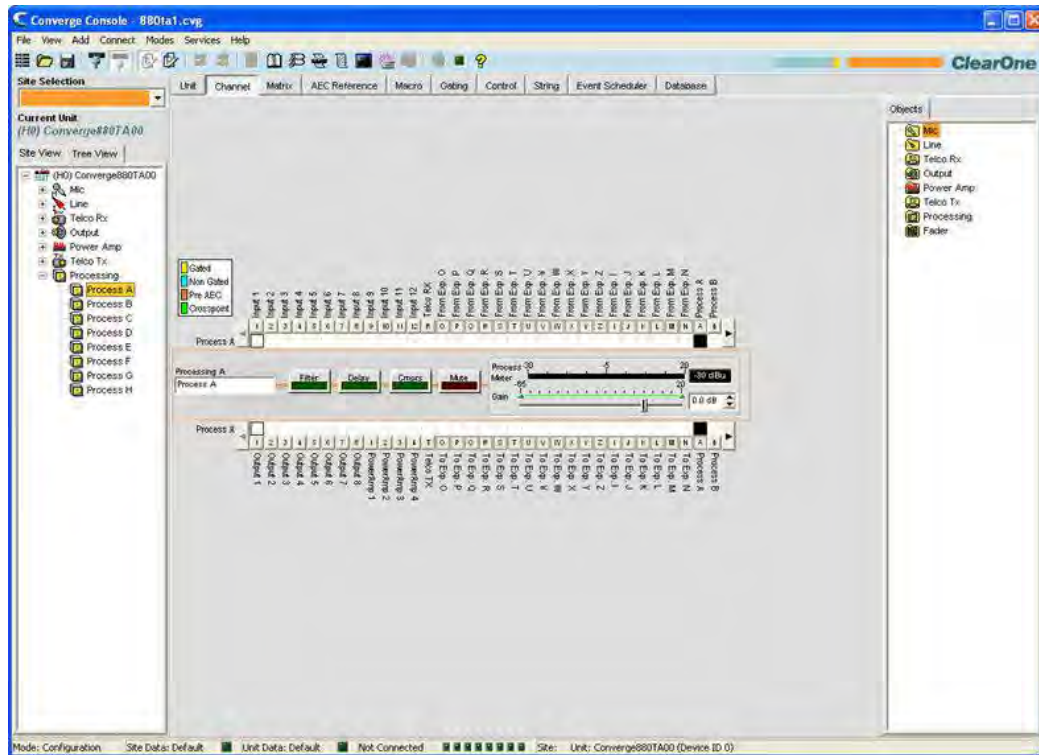

The center pane displays a signal processing diagram, meters, and configuration controls for selected processing block as shown above.

The meters and configuration controls for processing blocks are explained in the following sections.

Channel Label

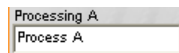

Rename the channel by entering a name in the Label entry field (optional). Label changes are global, and appear throughout Console wherever the label is referenced.

Filter Button



Pressing the **Filter** button brings up the **Channel Property Configuration** window with the **Filter Tab** selected as shown below.

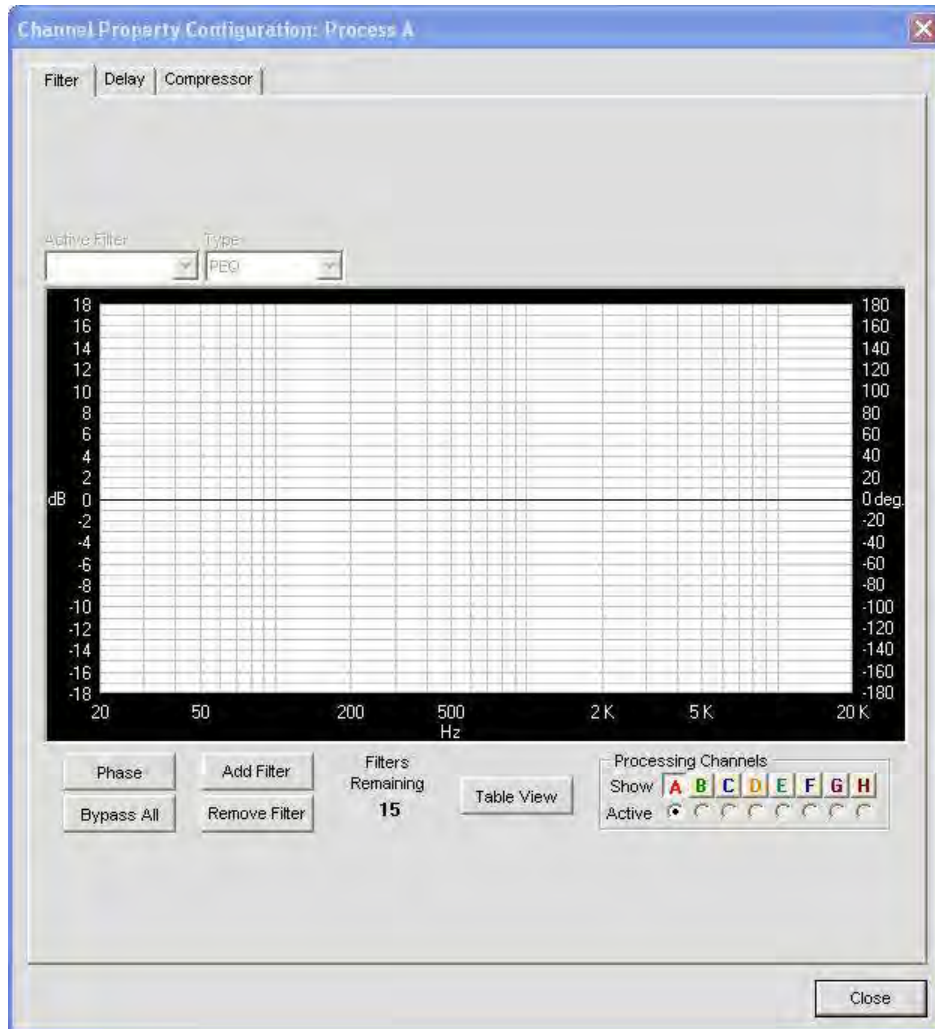

For more information on Filters and their configuration, use the *Table of Contents* to locate the *Filters* topic.

Delay Button



Press the **Delay** button to bring up the **Channel Property Configuration** window with the **Delay Tab** selected as shown below.



Introducing an appropriate amount of delay to the forward-mounted driver(s) re-establishes the acoustical alignment necessary for proper sound imaging in a room. The same principle of introducing delay applies to separate speaker enclosures located various distances from the listening area.

Other types of delay to consider when establishing delay parameters are delays which occur naturally as a result of processing within the unit. Propagation delay is an example. This delay is caused by operations such as the conversion of the signal between analog and digital formats.

Select the **Enable Delay** checkbox to enable it. Calibrate the amount of delay using the **Length** and **Temperature** configuration controls. **Length** is defined as the distance between the source and audience. The **Calculated Delay** reading reflects any changes you make in the **Distance** and **Temperature** fields.

Click **Close** to save changes and return to the **Process/Channel** window.

Cmprs (Compression) Button

Pressing the **Cmprs** button opens the **Channel Property Configuration** window with the **Compressor** tab selected as shown below.

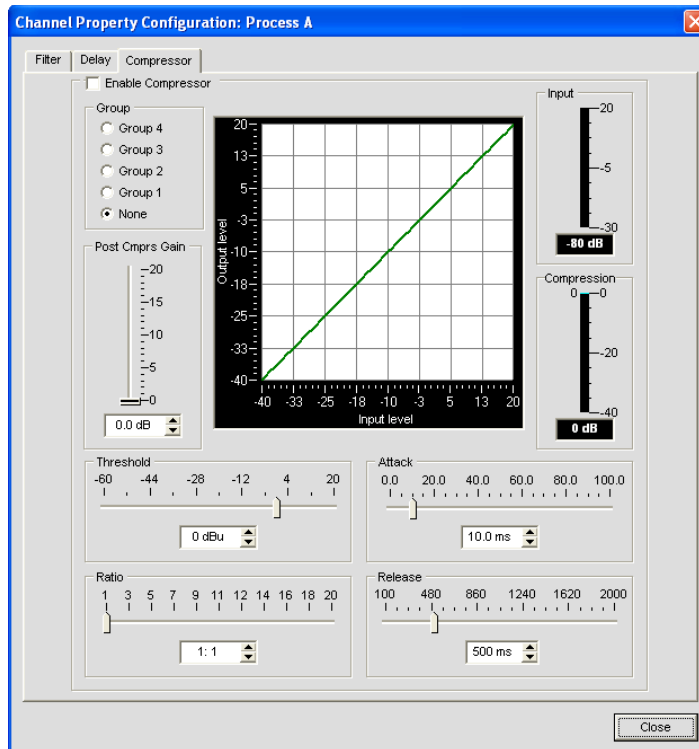

Select the **Enable Compressor** checkbox to activate the compressor. Using the compressor, you can change the gain transfer characteristics of the signal path and control the dynamics of a signal. Compressor settings are described below.

Group

Use the **Group** radio buttons to assign this compressor to a compressor group. The default is None. When you assign a compressor to a compressor group—such as a group of two compressors configured for left and right stereo channels—the compressors will monitor each other. When one channel compresses, all compressors in the group compress together.

A compressor group must be configured for a single unit; a group cannot control compressors from multiple units.

Post Compressor Gain

Adjust the compressor gain with the slider or by using the **Up/Down** arrow buttons. The graph reflects the input/output decibel levels with the gain, ratio, and threshold settings you select.

Threshold

Determines the RMS level at which the compressor begins to operate. The range is from -30 to +20dBu. The default is 0dBu.

Ratio

Changes the rate of compression applied to the input signal as the signal exceeds the threshold level. The range is 1:1 to 1:20dB. The default is 1:1.

Attack

Sets the time increment used to reduce the signal from input level to the prescribed output level when the threshold is exceeded. The range is 0 to 100ms in .5ms steps. The default is 10ms.

Release

Sets the time increment used to restore the signal to the input level when the signal drops below the threshold. The range is 100ms to 2 seconds, in 5ms increments. The default is 500ms.

Input Meter

Shows the level of the signal as it enters the compressor.

Compression Meter

Shows the instantaneous compression value at a given time.

Gain Slider & Process Meter

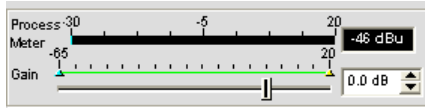

Use the **Gain Slider** to establish the gain level for this processing channel. Range is -65 to 20dB. The **Process Meter** shows the signal level when a signal is present.

Min/Max Limits

Use the yellow and green upper and lower limit arrows on the **Gain Scale** to set minimum and maximum gain level limits. These limits only apply when using relative gain commands; absolute gain commands can exceed the Min and Max limits. Min/Max limits apply to all serially connected control devices and prevent users from adjusting levels beyond the Min/Max levels, provided relative gain commands are used.

Channel Routing Matrix

The channel routing matrix shows the Matrix row and audio routing configuration for the selected channel (Process A in this case). Clicking a cross point box selects it, clicking it a second time sets the cross point, as indicated by a colored box. The dB level for set cross points is shown numerically in the box.

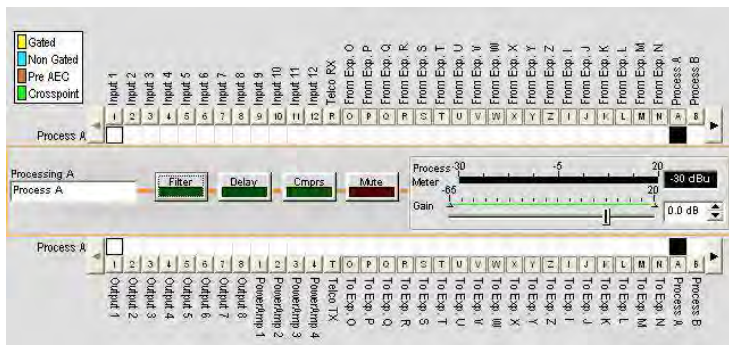

You can click directly on any cross point box to set a cross point, or leave it blank, as required for your installation. To adjust cross point gain/attenuation, right-click on a cross point box and select **Cross Point** from the shortcut menu.

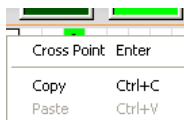

The **Cross Point Attenuation** slider appears as shown below. Move the slider or use the selector box to set the gain/attenuation level in dB. The range is from -60 to 12dB in .5dB increments. The default is 0dB.

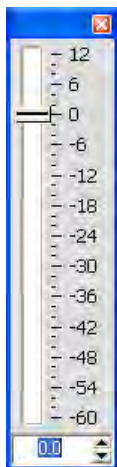

NOTE: Your changes are automatically saved when you close the slider.

Expanded Channel Routing Matrix

In the channel routing matrix, pressing the button above or below the cross point box for a channel displays the signal flow diagram and configuration controls for that channel as shown below.

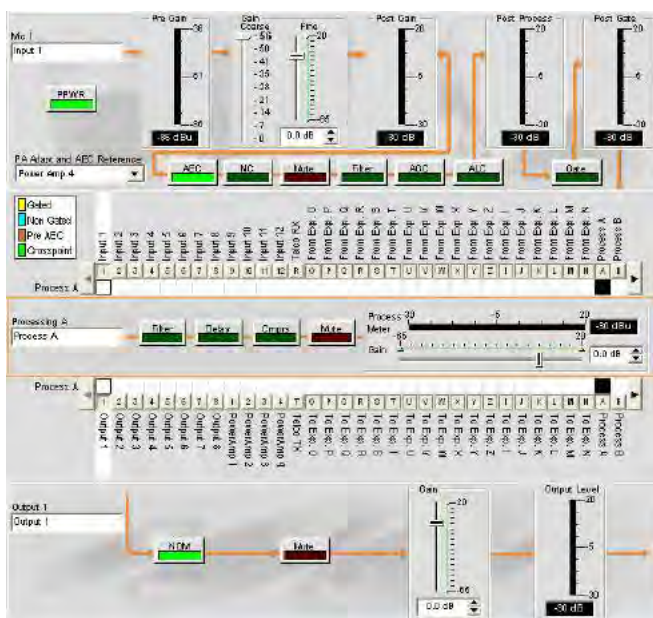

This display is identical to that shown in Channel when the channel is selected in the Tree View pane.

You can change the label (name) of the channel in the label entry box. You can also change channel configuration settings. For example, for an output channel you can toggle the NOM button to turn constant gain mode on or off, toggle the Mute button, and use the Gain slider to set the gain level for the channel.

NOTE: Changes to configuration settings made in the channel routing matrix apply globally to that channel. For example, changing the label (name) from “Input 1” to “Podium Mic” changes the name of the channel in the Tree View pane, and everywhere else the label appears in Console.

Creating Channel Objects

One of the most powerful features of Console is the ability to create Channel Objects. Channel objects capture all settings for the channel at the time the object is created. After configuring a processing channel using the Channel tab as described in this topic, you can save it into the Database, and use drag and drop configuration to streamline configuration tasks.

To save a processing channel configuration, right click in the processing section of the screen (surrounded by an orange rectangle). From the menu that appears, select **Export Object** as shown below.

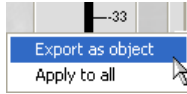

NOTE: You can apply the channel configurations for the current channel to all channels of the same type by selecting the **Apply to all** option. Use this option with caution because there is no way to undo the changes.

Enter an appropriate **Label** (name) in the entry field of **Export Object** dialog as shown below.

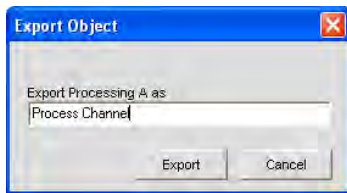

Click **Export** to save the configuration to the database, or **Cancel** to return to the Channel screen.

Console saves the object to the database and displays it in the **Object Tree** as shown below.

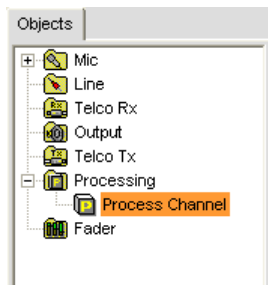

For more information on using AV devices and channel objects, see the following topics:

- **AV Devices**
- **Creating AV Devices**
- **Channel Objects**
- **Database Tab**
- **Drag & Drop Configuration**

For more information, refer to the *Table of Contents* for these related topics:

- **Channel Tab Overview**
- **Filters**
- **Line Input Settings**
- **Mic Input Settings**
- **Output Settings**
- **Processing Settings**
- **Fader Settings**
- **Telco/VoIP Rx Settings**
- **Telco/VoIP Tx Settings**
- **Drag & Drop Configuration**

FADER SETTINGS

NOTE: The CONVERGE Pro 880TA and CONVERGE SR 1212A do not have fader settings.

Fader Settings allow you to set configuration parameters for fader channels using the Channel tab. Fader channels are internal sub-bus channels similar to Processing channels that provide additional sub-bus mixes to control volume settings within a site.

Accessing Fader Settings

With the **Channel** tab selected on the **Tab Bar**, select the desired fader channel on the **Tree View** tab in the **Site Pane**.

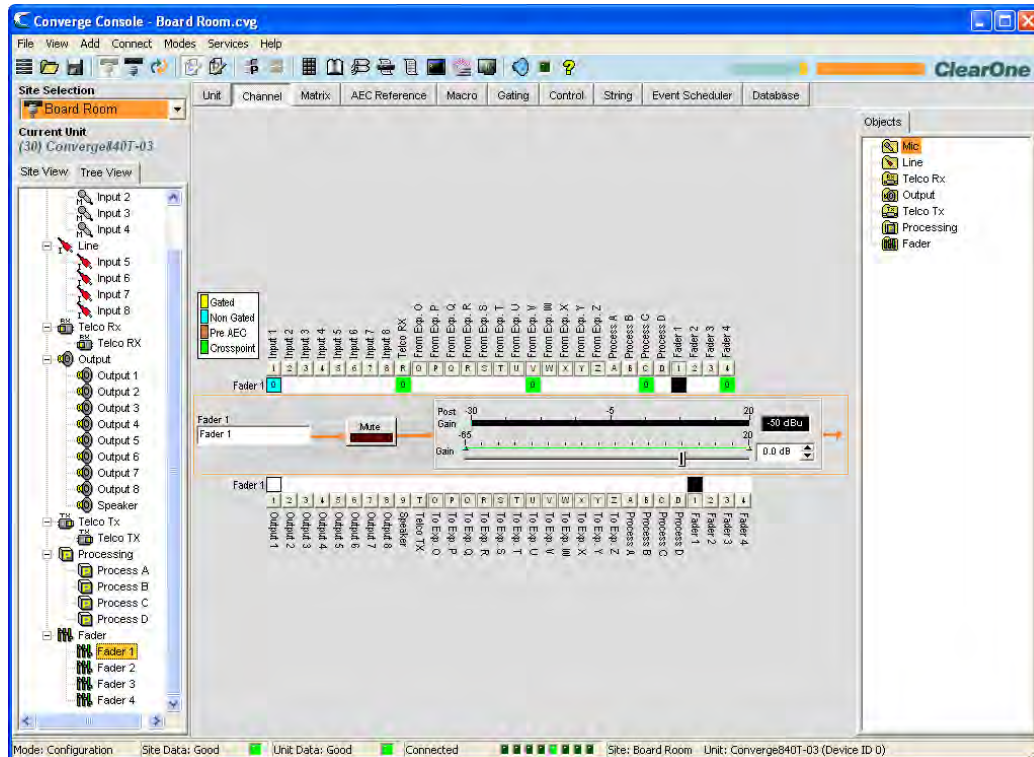

As shown above, the **Center Pane** displays the configuration controls and gating for the selected Fader channel. Fader configuration controls are described in the following sections.

Channel Label



Rename the channel by entering a name in the **Label** entry field (optional). Label changes are global, and appear throughout Console wherever the label is referenced.

Mute Button



Clicking the **Mute** button toggles muting. The default is Off.

Gain Slider & Post Gain Meter

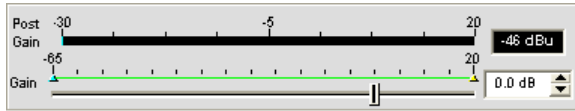

Adjusts output gain level. Use the **Gain** slider to adjust output volume level. You can also enter the level directly in the selector box. The **Post Gain** meter reflects the post-gain level of the signal in dB.

Min/Max Limits

Use the yellow and green upper and lower limit arrows on the **Gain** scale to create minimum and maximum gain level limits. These limits only apply when using relative gain commands; absolute gain commands can exceed the min and max limits. **Min/Max** limits apply to all serially connected control devices and prevent users from adjusting levels beyond the min/max levels.

Channel Routing Matrix: Faders

The channel routing matrix shows the **Matrix** row and audio routing configuration for the selected channel (Fader 1 in this case). Clicking a cross point box selects it, clicking it a second time sets the cross point, as indicated by a green box. The dB level for set cross points is shown numerically in the box.

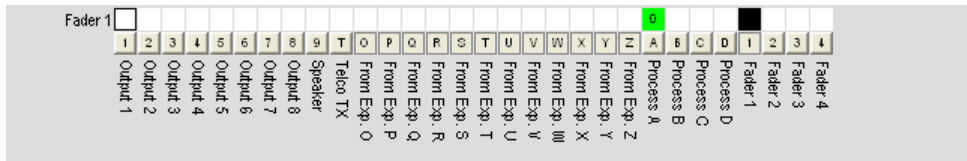

You can click directly on any cross point box to set a cross point, or leave it blank, as required for your installation.

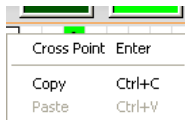

To adjust cross point gain/attenuation, right-click on a cross point box and select **Cross Point** from the shortcut menu.

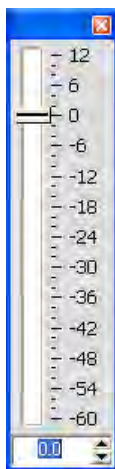

The **Cross Point Attenuation** slider appears. Move the slider or use the selector box to set the gain/attenuation level in dB. The range is from -60 to 12dB in .5dB increments. The default is 0dB.

NOTE: Your changes are automatically saved when you close the slider.

Expanded Channel Routing Matrix

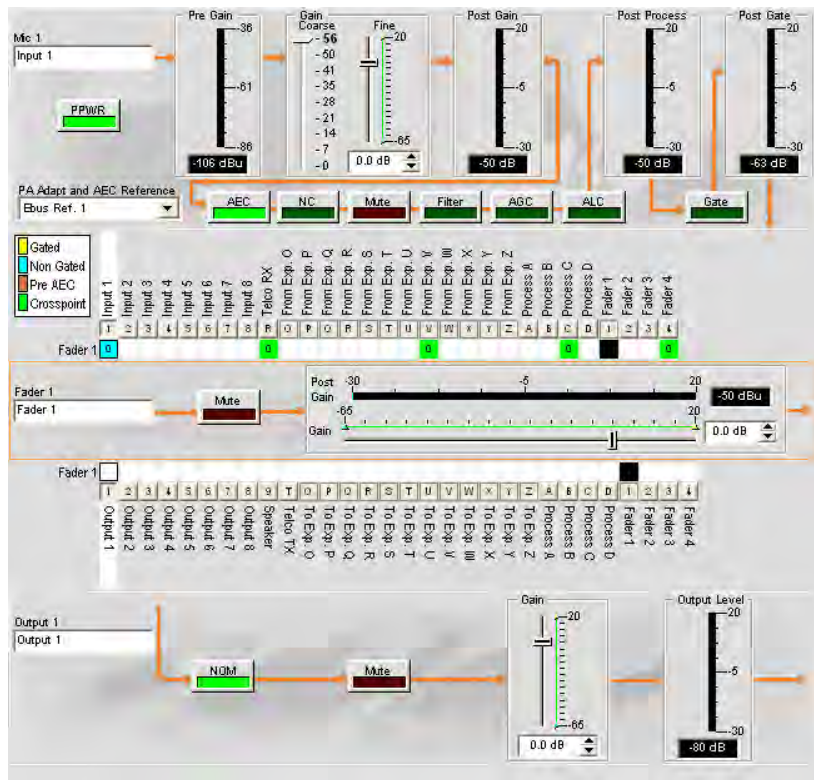

This display is identical to that shown on the Channel tab when the channel is selected in the Tree View pane.

You can change the label (name) of the channel in the label entry box. You can also change channel configuration settings. For example, for an output channel you can toggle the **NOM** button to turn constant gain mode on or off, toggle the **Mute** button, and use the **Gain** slider to set the gain level for the channel.

NOTE: Changes to channel configuration settings made in the channel routing matrix apply globally to that channel. For example, changing the label (name) from “**Output 1**” to “**Ceiling Speakers**” changes the name of the channel in the Tree View pane, and everywhere else the label appears in Console.

Creating Channel Objects

One of the most powerful features of Console is the ability to create Channel Objects. Channel objects capture all settings for the channel at the time the object is created. After configuring a fader channel using the Channel tab as described in this topic, you can save it into the Database, and use drag and drop configuration to streamline configuration tasks.

To save a fader channel configuration, right click in the fader section of the screen (surrounded by an orange rectangle). From the menu that appears, select **Export Object** as shown below.

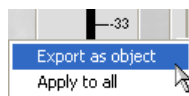

NOTE: You can apply the channel configurations for the current channel to all channels of the same type by selecting the **Apply to all** option. Use this option with caution because there is no way to undo the changes.

Enter an appropriate **Label** (name) in the entry field of **Export Object** dialog as shown below.

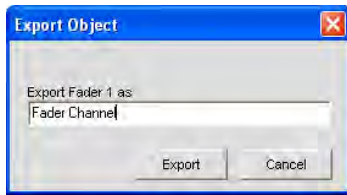

Click **Export** to save the configuration to the database, or **Cancel** to return to the Channel screen.

Console saves the object to the database and displays it in the **Object Tree** as shown below.

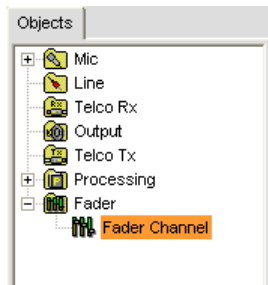

Group View

Group View for a desired Channel type can be entered from a click on the channel box label in Site View, or by clicking on the Channel Header in Unit View.

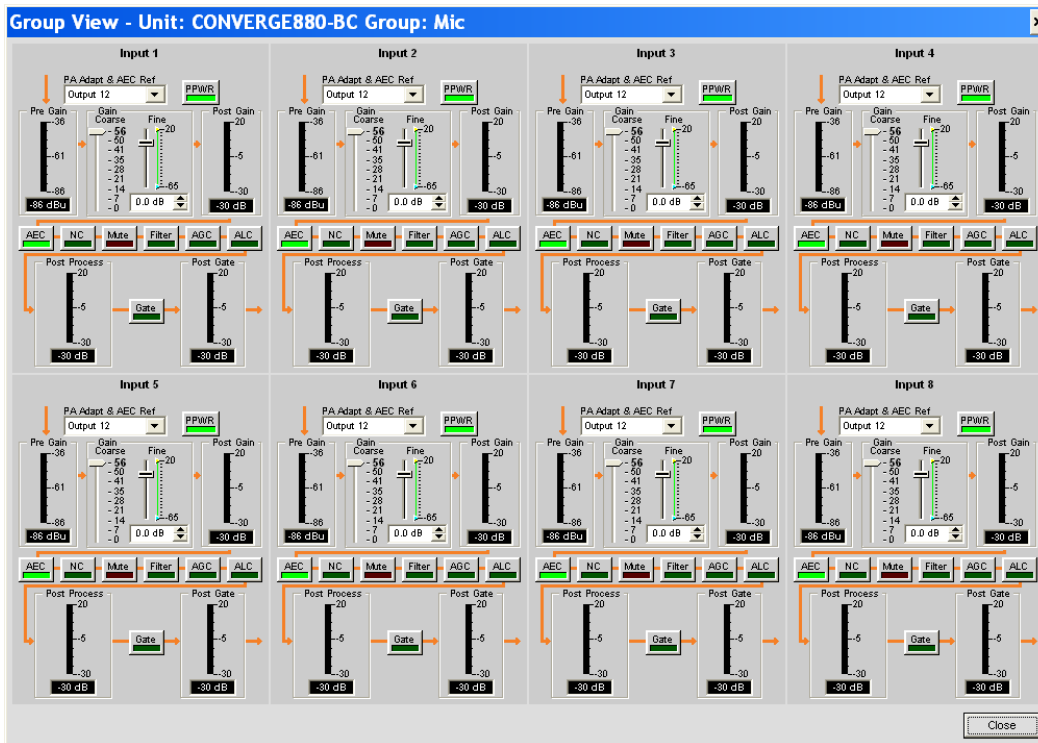

Group View shows all channels of the same type for a unit in one screen.

For more information on using AV devices and channel objects, see the following topics:

- **AV Devices**
- **Creating AV Devices**
- **Channel Objects**
- **Database Tab**
- **Drag & Drop Configuration**

For more information, refer to the *Table of Contents* for these related topics:

- **Channel Tab Overview**
- **Filters**
- **Line Input Settings**
- **Mic Input Settings**
- **Output Settings**
- **Processing Settings**
- **Fader Settings**
- **Telco/VoIP Rx Settings**
- **Telco/VoIP Tx Settings**
- **Drag & Drop Configuration**

MATRIX TAB

The **Matrix Tab** is used to route audio to one or more destinations (outputs, expansion bus, processing, or fader channels) and to create cross points between channels.

Accessing the Matrix

To access the matrix, select the **Matrix Tab** from the **Tab Bar** in Console.

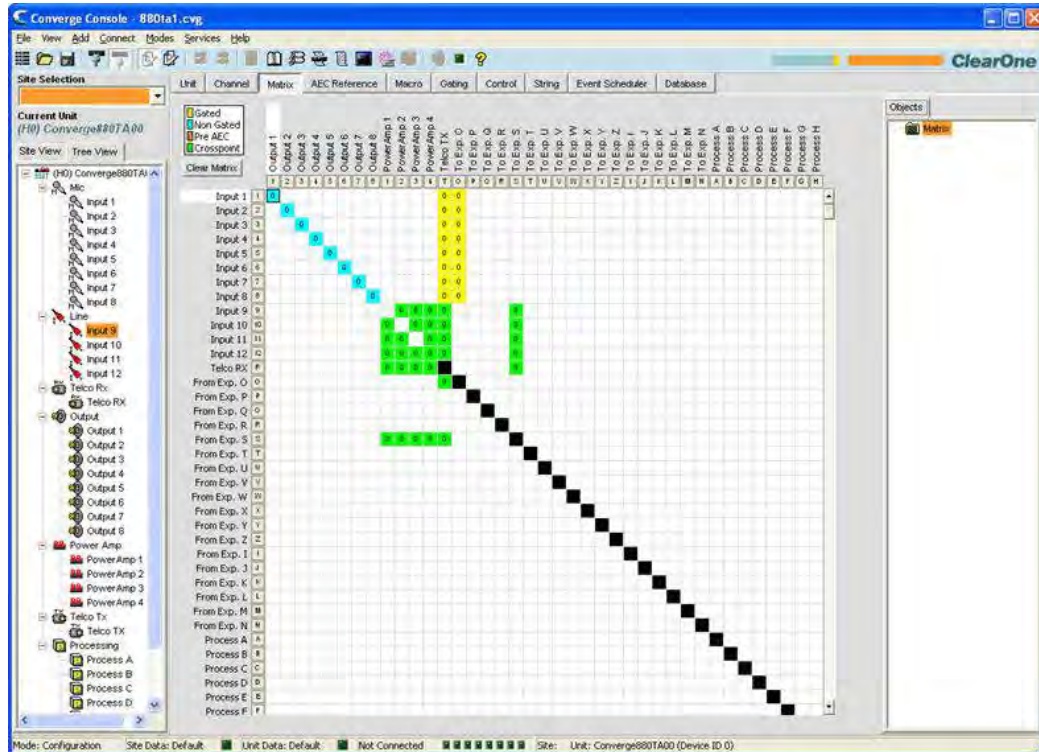

The matrix appears with the current routing configuration displayed for all channels. The functionality of the matrix screen is described in the following sections.

Routing Legend

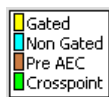

The routing legend shows the status of cross points using colored cells that mark the intersection or cross point of the routing from input to output. The color of the cross point cell identifies the input type:

- **Yellow** = gated mic input
- **Blue** = non-gated mic input
- **Brown** = pre-AEC
- **Green** = cross point

NOTE: The current audio level to the nearest dB is shown in cross point cells.

Black cell are restricted routing paths which prevent Telco, E-Bus, Processing, and Fader channels from being routed back to themselves.

Clear Matrix Button

Clear Matrix

Press the **Clear Matrix** button to clear ALL current matrix settings. A **Confirm** dialog appears asking you to confirm the clear matrix operation. Use caution when using this feature because the operation cannot be undone.

Audio Routing Matrix

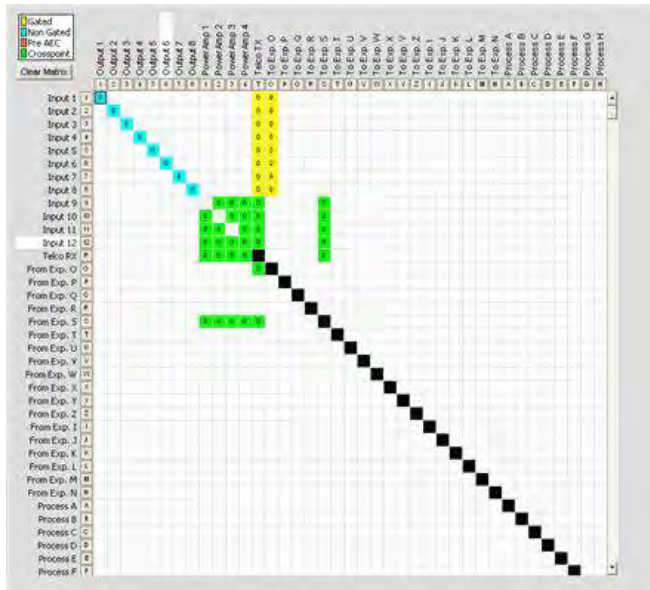

The numbers and letters along the top and left side of the matrix show the cross point coordinates. The Labels for each channel are also shown to make them easy to identify. As you move the cursor over the matrix, the labels for the channels are highlighted in white for each cross point.

NOTE: Clicking on a channel label opens the Channel screen for that channel, allowing you to modify the channel label and change channel configuration settings as needed.

Input Routing

To route an input to an output, click in the routing matrix at the intersection between the input and the output. A mic input can be designated as gated (yellow), non-gated (blue), or pre-AEC (brown) by clicking repeatedly in the cross point. All other input cross points will be colored green.

Expansion Bus I-Z Routing

Audio from any unit on the E-bus network can be placed on the bus or taken off the bus and routed to any destination within the unit. All models have 18 digital mix-minus buses:

- **S-Z Buses:** These eight audio buses are line input mixer buses. They are used to route auxiliary audio, such as from a CD player VCR, or CONNECT device, to and from other units on the network. These buses are also used as mic mixer buses when NOM count is not required.
- **I-R Buses:** These ten audio buses are generally used for routing microphone audio between CONVERGE/ CONVERGE Pro devices. Information about the number of gated microphones (NOM count) and other relevant information for the microphone mixers are tracked for microphones routed to these buses. By default, all microphones are routed to the O bus.

Process A–D (840T) and Process A–H (880, 880T, 880TA, 8i, SR 1212, SR 1212A) Routing

There are four processing channels on the CONVERGE Pro 840T, eight on the 880, 880T, 880TA, 8i, and eight on the CONVERGE SR 1212 and SR 1212A. Processing channels enable you to apply filters, compression, delay, and other processing settings to an input or a group of inputs, which can then be routed to a single output or group of outputs.

Cross Point Shortcut Menu

In addition to setting levels, the **Cross Point Shortcut Menu** (shown below) enables you to copy and paste the configuration of the current cross point to other cross points. To access the shortcut menu, right-click anywhere in the **Center Pane** of the **Matrix** screen.

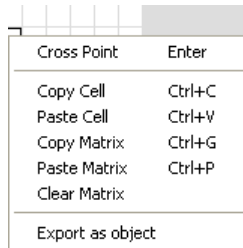

Cross Point Level Control

To adjust the level for a cross point, right-click on the cross point and select **Cross Point** from the shortcut menu. The **Cross Point Attenuation** slider appears. Move the slider or use the selector box to set the gain/attenuation level in dB. The range is from -60 to 12dB in .5dB increments. The default is 0dB.

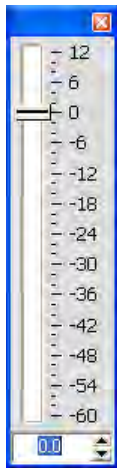

NOTE: Your changes are automatically saved when you close the slider.

The level you select now appears numerically in the cross point box within the matrix.

Copy and Paste Cells

You can copy a single cell or the entire matrix using the shortcut menu options.

To copy a cross point to multiple cross points, press **<Ctrl+C>** to copy, then press **<Ctrl+V>** while holding down the left-mouse button and clicking on the cross points to which you want to copy the settings.

Copy and Paste Matrix

To copy the entire matrix, use the shortcut menu commands; or press **<Ctrl+G>** to copy the matrix, select the unit you want to copy the matrix to in the **Site View Tab**, and press **<Ctrl+P>** to paste the matrix into the matrix screen for the selected unit.

Clear Matrix

Press the **Clear Matrix** button to clear all current matrix settings. A **Confirm** dialog appears asking you to confirm the operation. Use this option with caution because the operation cannot be undone.

Exporting Matrix Objects

Matrix objects allow you to save customized matrix configurations into the Database and reuse them. This enables you to instantly re-configure the entire matrix to accommodate changes in conferencing or venue configuration requirements, and to rapidly configure additional units using drag and drop configuration.

To capture the current matrix configuration and save it as a matrix object, right click anywhere in the center pane of the matrix screen and select Export as object from the shortcut menu.

To apply a matrix object, drag it from the Objects Pane and drop it onto the matrix in the Matrix Tab screen.

For more information on using AV devices and objects, refer to the *Table of Contents* for these related topics:

- **Controls and Connections**
- **Channel Tab Overview**
- **Expansion Bus Overview**
- **NOM**
- **Mic Gating**
- **Filters**
- **Processing**
- **Database Tab**
- **Drag & Drop Configuration**
- **Line Input Settings**
- **Mic Input Settings**
- **Telco/VoIP Rx Settings**
- **Output Settings**
- **Telco/VoIP Tx Settings**
- **Fader Settings**

AEC REFERENCE/PA ADAPT REFERENCE TAB

The **AEC Reference (880, 880T, 880TA, 840T, 8i, TH20, VH20)/PA Adapt Reference (SR 1212, SR 1212A) Tab** allows you to establish reference sources for Acoustic Echo Cancellation (AEC) and PA Adaptation. AEC uses reference signals as the basis for acoustic echo cancellation. An AEC reference is a digital sample of the receive audio signal that is used by the AEC filter model for adaptation and convergence. A PA Adapt Reference allows you to specify an output as the ambient reference to prevent an audio signal from gating on microphones (without interfering with speech from conference participants).

You can use both unit and expansion bus audio sources as AEC and PA Adapt references for the Mic Inputs connected to a unit. In addition, you can define virtual reference sources that combine multiple audio signals into a single AEC/PA Adapt reference source. Virtual references improve AEC performance in stereo speaker and combined audio/video conferencing applications.

Accessing AEC Reference/PA Adapt Reference

To access AEC Reference/PA Adapt Reference, select the unit that you want to define references for in the **Tree View Tab** of the **Site Pane**, then select the **AEC Reference/PA Adapt Reference Tab** from the **Tab Bar** in Console.

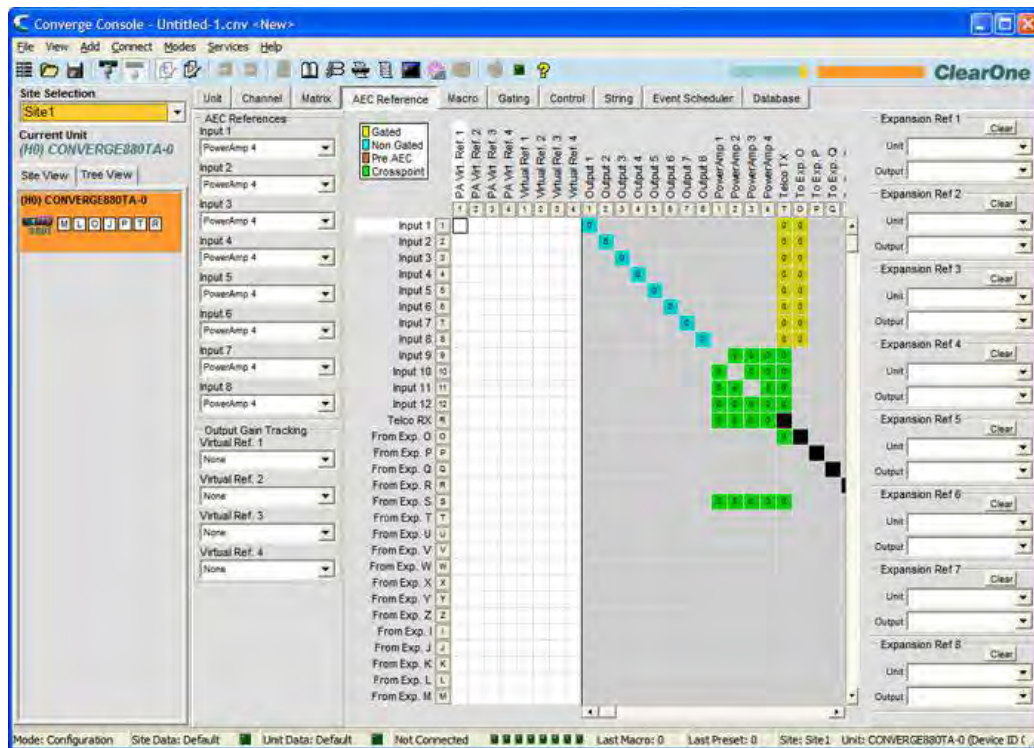

The **AEC/PA Adapt Reference** screen appears in the center pane of Console. AEC/PA Adapt reference configuration is explained in the following sections.

AEC/PA Adapt References Sources

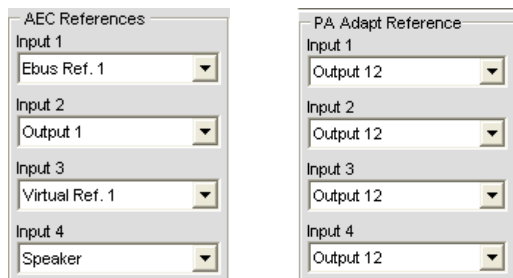

Use the drop-down lists to select an AEC/PA Adapt reference for each input channel as required for your application. As shown above, you can select any of the following as a reference source in the **AEC/PA Adapt References** section of the screen:

- Output channels (880, 880T, 880TA, 840T, TH20, SR 1212,SR 1212A)
- Expansion bus channels
- Speaker outputs (880T, 880TA, 840T only)
- Virtual references (880, 880T, 840T, TH20, VH20, SR 1212, SR 1212A)

Virtual AEC/PA Adapt References

Virtual AEC/PA Adapt References allow you to combine multiple audio sources for applications where there are two speakers (left and right) providing audio, combined audio/video conferencing, and audio/video teleconferencing. In these and other multiple output applications, using virtual AEC/PA Adapt references improves AEC performance.

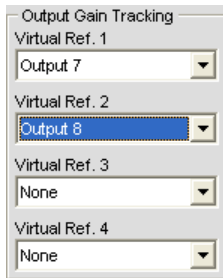

AEC requires a physical output reference to track output gain changes. Therefore when using virtual AEC/PA Adapt references, you must use output gain tracking to provide level information to the AEC process. Use the **Output Gain Tracking** section of the screen (shown above) to specify the level source for each virtual reference that you define.

Virtual AEC/PA Adapt reference sources are defined in a special section of the Matrix (shown below, highlighted in white):

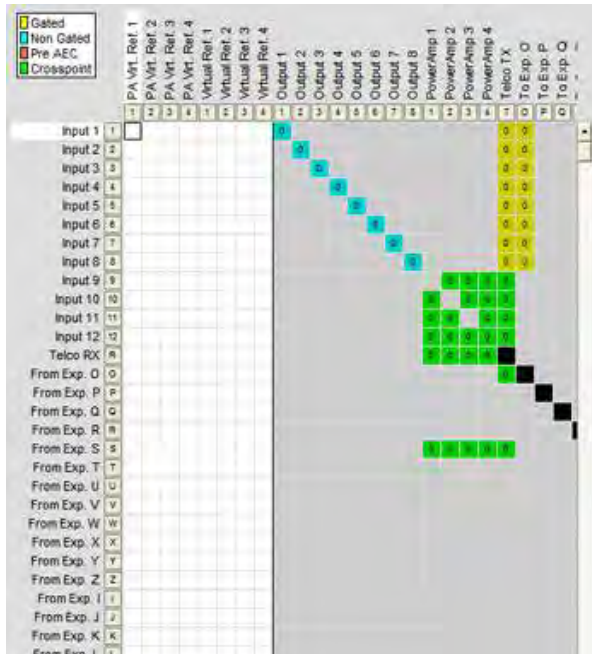

Use the white cross point area to select the outputs for each virtual reference source you want to define. In the example above, **Output 7** is connected to the room amplifier. This audio includes microphones that cannot be included in the AEC reference, so Output 7 should not be used directly as the AEC reference source. Instead, use a Virtual Reference and route any inputs that you want cancelled to that reference. This typically would include **Telco/VoIP Rx** audio and audio from a video codec (**Input 5** above), which in this example are combined to create **Virtual Reference 1**.

NOTE: If the channels selected for a virtual reference use Processing or Faders, you should select the processing or fader channel as the virtual reference source. This provides the AEC process with the most accurate reference for the signal, thereby providing faster convergence and more accurate AEC performance.

Expansion Bus Reference Sources

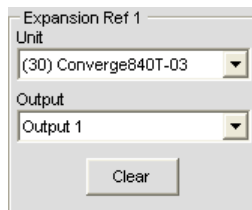

Expansion Ref 1
Unit
(30) Converge840T-03
Output
Output 1
Clear

Use the **Expansion References (1-8)** section of the screen to use audio from an expansion bus channel as the AEC/PA Adapt reference source. For each expansion reference, select the **Unit** and the **Output** you want to use as a reference using the drop-down lists.

The following types of sources are available for use as expansion AEC/PA Adapt reference sources:

- **Output channels**
- **Speakers**
- **Virtual references**

PA Virtual References

A PA Virtual Reference assigns audio from a given amp output and applies the same processing to a corresponding Amp Channel. All processing and audio information is applied to the Amp Channel. (For example, if the feedback eliminator is enabled on PA channel 2 the feedback eliminator adds a new node. That same feedback node will be added to the audio contained on PA Virtual Channel 2.)

For more information, refer to the *Table of Contents* for these related topics:

- **AEC (Acoustic Echo Cancellation)**
- **Mic Input Settings**
- **Processing Settings**
- **Fader Settings**

MACRO TAB

Macros define a series of commands which can be run using the Front Panel LCD, Serial Commands, Control Ports, Presets, the Web Portal, SNMP, and other macros.

Macros allow you to make quick configuration changes and to execute multiple Presets simultaneously. Macros can also contain commands that are executed on other units on the E-bus.

All models support up to 255 macros (with an average of 150 command lines each). In the unlikely event that you exceed Console's memory capacity, a warning appears indicating the command line at which memory is exceeded.

Accessing Macros

To access macros, press the **Macro Tab** on the **Tab Bar** in Console.

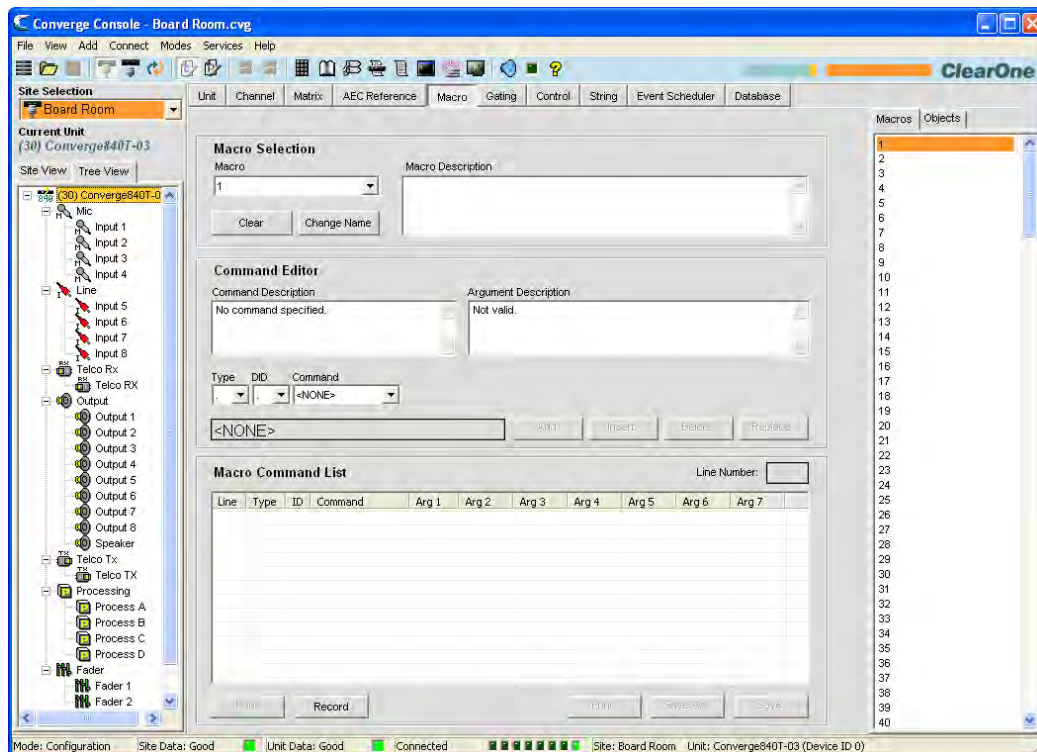

There are two ways to create macros in Console: the Macro Recorder, which records screen selections, and the Macro Editor, which allows you to create command lines. The Macro Editor is also used to modify macros created using the Macro Recorder.

Macro Recorder

Use the following procedure to record a macro using Macro Recorder:

1. Click the **Record** button at the bottom of the Macro screen. The Macro dialog appears.

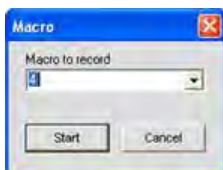

2. Select the macro number from the **Macro to Record** drop-down list, then click **Start**.
3. The Macro Record dialog appears (shown below).

4. In the Console, make the routing and input/output configuration changes (such as gain adjustments, mute, etc.) that you want to include in the macro.
5. Click **Stop** in the Macro Record dialog to end macro recording.
6. The macro Command Editor appears with a list of the commands captured.

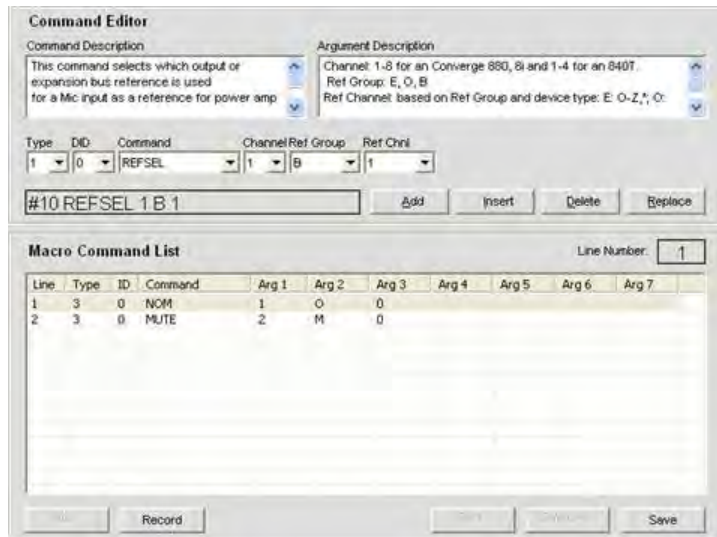

7. Click **Save** to save the macro.

You can use the Macro Editor to modify recorded macros as described in the next section.

Macro Editor

Creating Macros

Use the following procedure to create a macro using the Macro Editor:

1. Select the Macro number to create from the **Macro** drop-down list.



NOTE: Used macros are indicated by an asterisk in the macro drop-down list.

2. Press **Change Name** to assign a name to the macro (optional). Enter the name into the **Change Name** dialog that appears.

NOTE: Macro names appear in Console macro lists and on the LCD Macro menu. Using brief descriptive names makes it easier to identify a macro's functionality.

3. Enter a description of the macro's functionality in the **Macro Description** entry field (optional).
4. Select the device **Type**, **DID** (Device ID number), and **Command** from the drop-down lists.
5. When you select a command, a description of it appears in the **Command Description** box. The parameters associated with the command also appear, along with the valid values or range for each parameter, in the **Argument Description** box (shown below).
6. Set the parameter values for the command as required (optional).

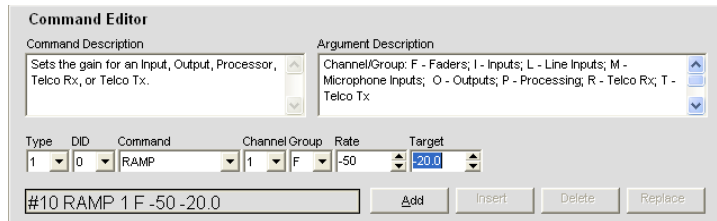

- Click **Add** to add the command to the end of the macro, or **Insert** to insert the command before the currently selected row of the macro. The command appears in the **Macro Command List**.

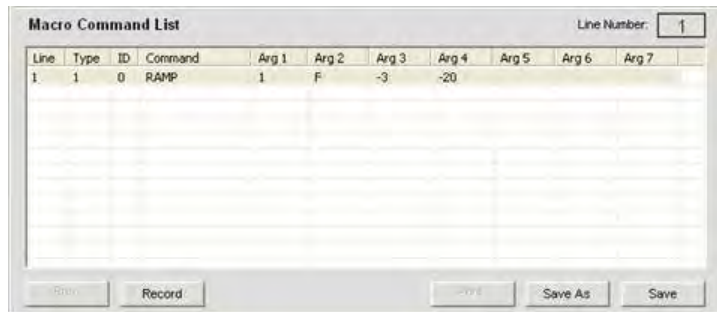

NOTE: When there are multiple commands in the Macro Command List, you can drag and drop them to change their execution order.

You can now add another command (repeat steps 4 through 6), or click **Save** or **Save As** to save the completed macro.

Modifying Macros

Use the following procedure to edit a macro:

- Select the Macro number to modify from the **Macro** drop-down list.
- Click **Change Name** to change the macro name (optional).
- Double-click the command line in the **Macro Command List** you want to edit.
- Modify the command or its arguments by selecting options from the drop-down lists.
- Click **Replace** to overwrite the old command line with the new changes.
- Click **Insert** to insert a new command, or **Delete** to delete the currently highlighted command.
- When you are finished making changes, click **Save** or **Save As** to save the macro.

Deleting Macros

Use the following procedure to delete a macro:

- Click **Clear Macro** to delete the entire macro.
- Click **Delete** to delete the selected command line.

Adding and Inserting Command Lines

Use the following procedure to add or insert command lines into the currently selected macro:

- Click **Add** to place the current command line into the next available row in the command line table.
- Click **Insert** to insert the current command line into the row directly above the currently selected command line in the table.
- When you are finished making changes, click **Save** or **Save As** to save the macro.

Running Macros

Running Macros Using Console

Use the following procedure to run a Macro from Console:

1. Select the **Macro** tab from the Console main screen or press the **Run Macro**  button on the button bar (only available when Console is in Configuration mode).
2. Select the macro from the **Select Macro** list.
3. Click **Run** to run the macro and close the window.

Running Macros Using the Front Panel

Use the following procedure to run a macro from the front panel:

1. Using the **Menu Dial**, select the **Macros Menu**.
2. Select the macro you want to run from list and press the **Select** button.
3. Answer **Yes** when prompted to run the macro, or **No** to cancel.

Running Macros Using Control Devices

Refer to the *Control Tab* topic for information on running macros using control devices.

Exporting Macro Objects

Macro Objects allow you to save macros into the **Database** and reuse them. To capture a macro and save it as an object, right click anywhere in the center pane of the macro screen and select **Export as object** from the shortcut menu.

For more information about objects, see **Creating Channel Objects, Matrix Objects, Control Objects, and Drag & Drop Configuration**.

For additional information, refer to the *Table of Contents* for these related topics:

- **Controls and Connections**
- **Expansion Bus Overview**
- **Device IDs**
- **LCD Programming Overview**
- **LCD Macros Menu**
- **Presets**
- **Configuration Mode**
- **Control Tab**
- **Database**
- **Channel Objects**
- **Matrix Objects**
- **Control Objects**
- **Drag & Drop Configuration**

GATING TAB

The **Gating** tab allows you to create gating groups and assign mic inputs to gating groups.

Gating group assignments combine individual channel gating configurations created using the **Channel Properties Configuration** screen. When inputs are assigned to a gating group, the gating information from the assigned inputs is used to control how the entire mixer behaves.

The CONVERGE/CONVERGE Pro product family (excluding the TH20/VH20) features four internal gating groups (**Internal 1–4**), and six global gating groups across the expansion bus (**Global A–F**). Mic inputs are assigned to **Global Group A** by default. If an input is not assigned to a gating group, that mic's gating properties are independent, and they have no effect on any gating group. When gating groups span two or more units (global gating groups), the settings must be the same for each unit attached to the global gating group.

NOTE: Mic inputs can be assigned to one and only one Gating Group at a time.

Accessing Gating Groups

To access gating groups, click the **Gating Tab** on the **Tab Bar** in Console.

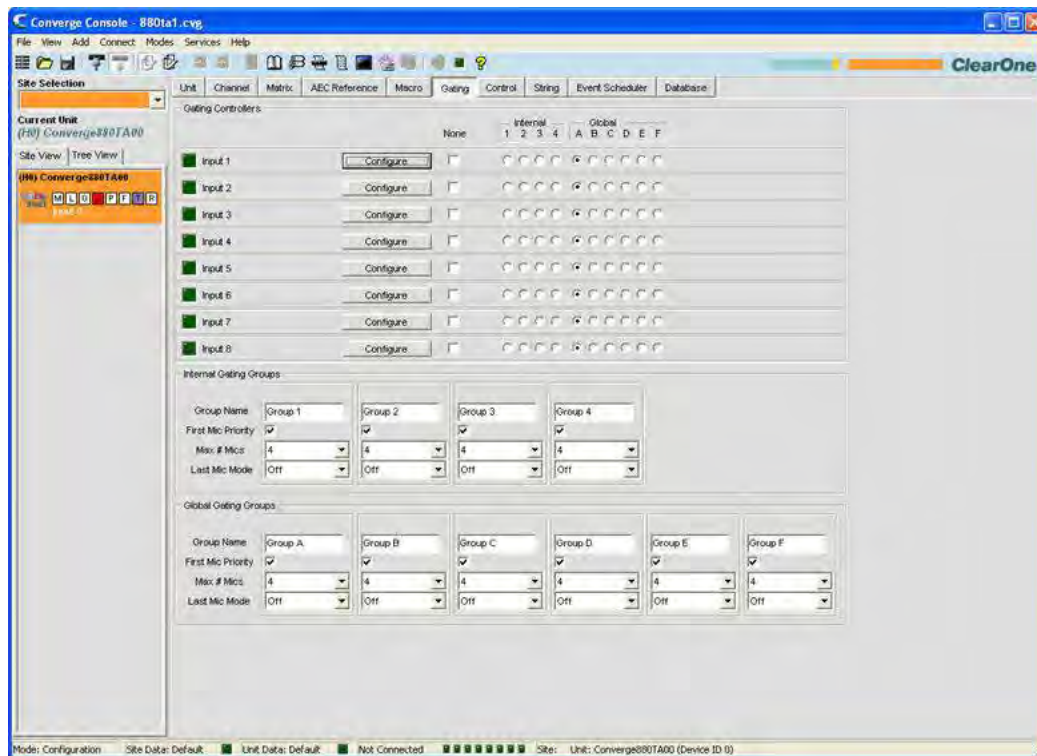

Gating configurations are shown in the **Center Pane**. The following sections describe how to configure gating groups.

Gating Controllers



Use the **Gating Controllers** section of the screen to assign **Mic Inputs** to a gating group. Use **Internal** gating groups (radio buttons **1-4**) to control mic inputs connected to the unit currently selected in the **Site Pane**. Use **Global** gating groups (radio buttons **A-F**) to control mic inputs connected to the current unit, as well as all units connected to the E-Bus.

Press the **Configure** button to display and modify individual channel **Gating** configurations using the **Channel Properties Configuration** screen.

Internal Gating Groups

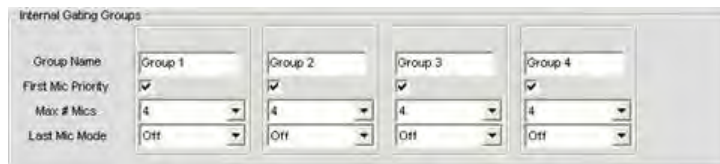

Internal gating groups control mic inputs connected to a specific unit. Configure Internal Gating Group settings as follows:

- Enter a name in the **Group Name** field (optional).
- Select the **First Mic Priority** checkbox to enable this feature (default), or deselect it to turn First Mic Priority off.

NOTE: ClearOne recommends using First Mic Priority to maintain maximum audio intelligibility by allowing only one mic to gate on to a participant's voice. First Mic Priority allows more than one microphone to gate on at same time, but it restricts more than one mic from gating on to the same audio source. It does this by determining the audio level received by all mics when the first mic is gated on, and then using this audio level as the ambient level for the gating group. If First Mic Priority is disabled, two or more microphones will usually gate on when only one person speaks.

- Select the **Max # of Mics** from the drop-down list (the default is 4). This sets the maximum number of microphones that can be gated on at any one time within a gating group. The maximum number of mics is limited to the number of mics included in the gating group. For internal gating groups, the maximum number of mics is 8 for CONVERGE Pro 880, 880T, 880TA 8i, CONVERGE SR 1212 and SR 1212A units, and 4 for CONVERGE Pro 840T units.
- Select the **Last Mic Mode** from the drop-down list (the default is off). **Last On** leaves the last mic activated gated on until another mic gates on. The **Input** options allow you to select which mic remains on when all other mics gate off. **Off** gates all mics off when no audio is present. **All** allows all mics to gate on at the same time.

Global Gating Groups



Global gating groups control mic inputs connected to all units linked together through the **Expansion Bus**. Configure **Global Gating Group** settings as follows:

- Enter a name in the **Group Name** field (optional).
- Select the **First Mic Priority** checkbox to enable this feature (default), or deselect it to turn First Mic Priority off.

NOTE: ClearOne recommends using First Mic Priority to maintain maximum audio intelligibility by allowing only one mic to gate on to a participant's voice. First Mic Priority allows more than one microphone to gate on at same time, but it restricts more than one mic from gating on to the same audio source. It does this by determining the audio level received by all mics when the first mic is gated on, and then using this audio level as the ambient level for the gating group. If First Mic Priority is disabled, two or more microphones will usually gate on when only one person speaks.

- Select the **Max # of Mics** from the drop-down list (the default is 4). This sets the maximum number of microphones that can be gated on at any one time within a gating group. Again, the maximum number of mics is limited to the number of mics included in the gating group. For global gating groups, the maximum number of mics is eight, up to a maximum of 96 microphones in E-bus linked systems.
- Select the **Last Mic Mode** from the drop-down list (the default is off). **Last On** leaves the last mic activated gated on until another mic gates on. The **Input** options allow you to select which mic remains on when all other mics gate off. **Off** gates all mics off when no audio is present.

For additional information, refer to the *Table of Contents* for these related topics:

- **Mic Input Settings**
- **Channel Tab Overview**
- **Mic Gating**
- **Expansion Bus Overview**

CONTROL TAB

The **Control Tab** allows you to configure pin assignments for the user-definable pins on Control/Status Port A and Control/Status Port B.

All models implement control/status using DB-25 pin ports on the back panel, and GPIO (General Purpose Input Output) with active low/pull to ground inputs and open collector outputs. For details, refer to *Appendix B* and the *Control/Status Ports* section of *Appendix D: Specifications*.

The control ports enable external devices to access the CONVERGE/CONVERGE Pro serial command set, including common functions such as volume control, muting, room combining, and preset changes. All devices connected via the E-bus can be controlled from a single control/status port on any of the devices.

Accessing the Control Tab

To access command control, press the **Control Tab** on the **Tab Bar** in Console.

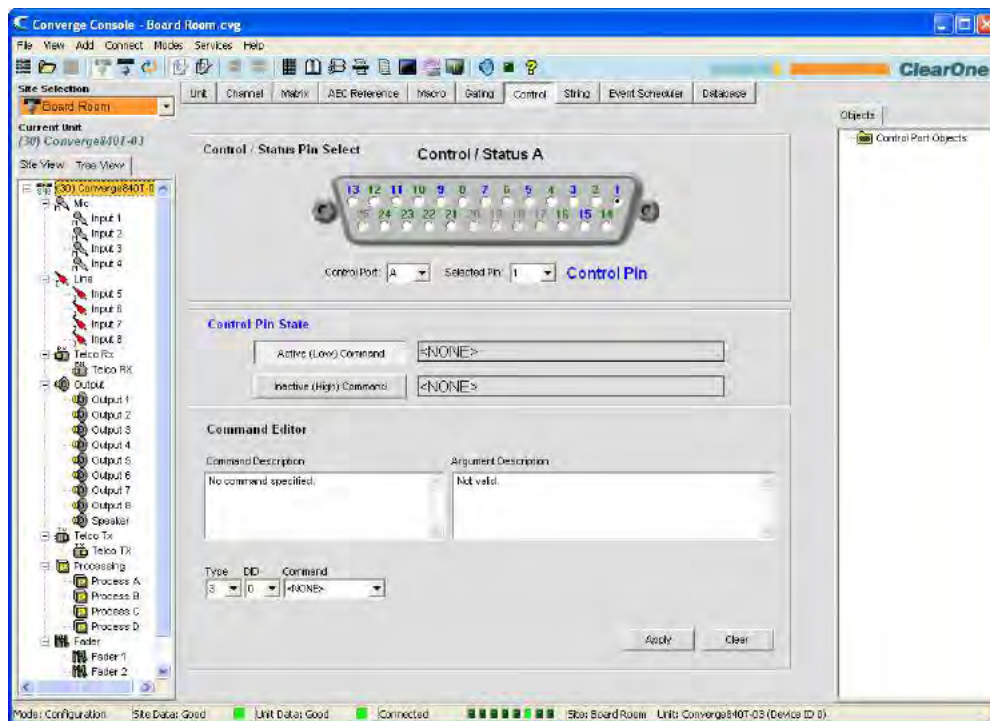

The **Control** tab of the Console main screen shows a graphical representation of **Control/Status Port A**. The pins numbered in blue are user-definable command pins; the pins numbered in green are status pins. Control interface functionality and pin programming are explained in the following sections.

User-Definable Pins

The user-definable pins provide control via contact closure, and status via open collector functions in the unit. There are two user-definable pins on the B port of every unit. The number of user-definable pins on the A port varies by model, as summarized in the following table:

Model	User-Definable Pins Control/Status Port A	User-Definable Pins Control/Status Port B
880	16	2
880T	16	2
880TA	16	2
840T	20	2
8i	16	2
TH20	24	2
VH20	24	2
SR 1212	16	2
SR 1212A	16	2

Default Pin Assignments

For default pin assignments for Control/Status ports by model, refer to *Appendix B*.

Control/Status Ports

Control/Status A and B ports are female DB25 connectors used for General Purpose Input/Output (GPIO) interactions between CONVERGE/CONVERGE Pro devices and external control devices such as wall switches and push-to-talk microphones. Control programming enables external control devices and controller software to access the CONVERGE/CONVERGE Pro serial command set, including common functions such as volume control, muting, room combining, and running presets.

For more information on **Control/Status Port A and B** and other physical connections, see **Controls and Connections**.

Control/Status Pin Programming

Use the following procedure to program user-definable pins:

1. In the **Control/Status Pin Select** section of the screen, select port **A** or **B** from the **Control Port** drop-down list.



2. Select the pin you want to configure from the **Selected Pin** drop-down list. (**Pin 1** is selected by default for **Control Port A** and **Pin 21** is selected by default for **Control Port B**.)

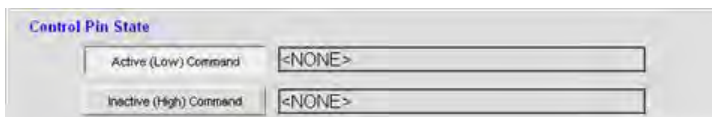

3. In the **Control Pin State** section of the screen, press the **Active (Low) Command** or **Inactive (High) Command** button to select the pin state that you want to associate a command with.

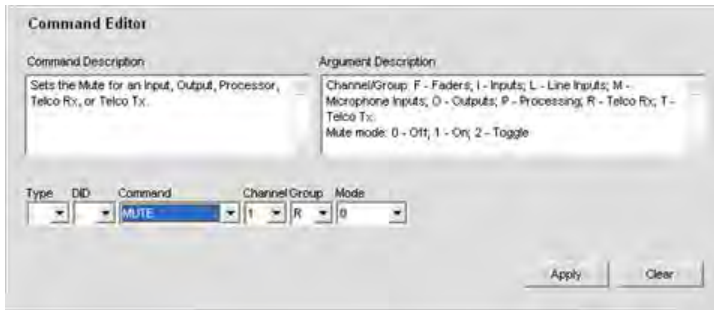

4. In the **Command Editor** section of the screen, select the device **Type**, **DID**, and **Command** from the drop-down lists. When you select a command, its description appears in the **Command Description** box. The parameters associated with the command appear next to the **Command** drop-down list, and the valid values or range for each parameter appear in the **Argument Description** box.



5. Set parameter values for the command as required, then press the **Apply** button. The command appears in the selected **Active/Inactive Command** text box.
6. To complete programming for the selected pin, repeat steps 3 through 6 to set the **Active Command** for the opposite pin state.
7. Repeat steps 1 through 6 to program additional pins.

Clearing Pin Programming

To clear programming for a pin, select the **Control Port** and **Selected Pin** using the drop-down lists, select the pin state using the **Active Command** buttons, then press the **Clear** button. To clear all pins, right-click and select **Clear All** from the shortcut menu.

Exporting Control Objects

You can save control port objects into the CONVERGE/CONVERGE Pro database. To capture the currently displayed control pin programming, right click in the **Control/Status Pin Select** portion of the of the **Control Tab** screen, and select **Export as object** from the shortcut menu. After saving the control port object, it appears in the **Objects** pane on the right side of Console.

For more information about objects, see **Creating Channel Objects**, **Matrix Objects**, **Macro Objects**, and **Drag & Drop Configuration**.

For additional information, refer to the *Table of Contents* for these related topics:

- **Expansion Bus**
- **Controls and Connections**
- **Device IDs (DIDs)**
- **String Tab**

STRING TAB

The String Tab enables you to create up to eight command strings that allow CONVERGE/CONVERGE Pro units to control external devices such as lighting, projectors, and room dividers. Command strings are written using the syntax of the external device being controlled. CONVERGE/CONVERGE Pro devices pass command strings to external devices through the RS-232 port.

Accessing the String Tab

To create command strings, press the **String** tab on the **Tab Bar** in Console.

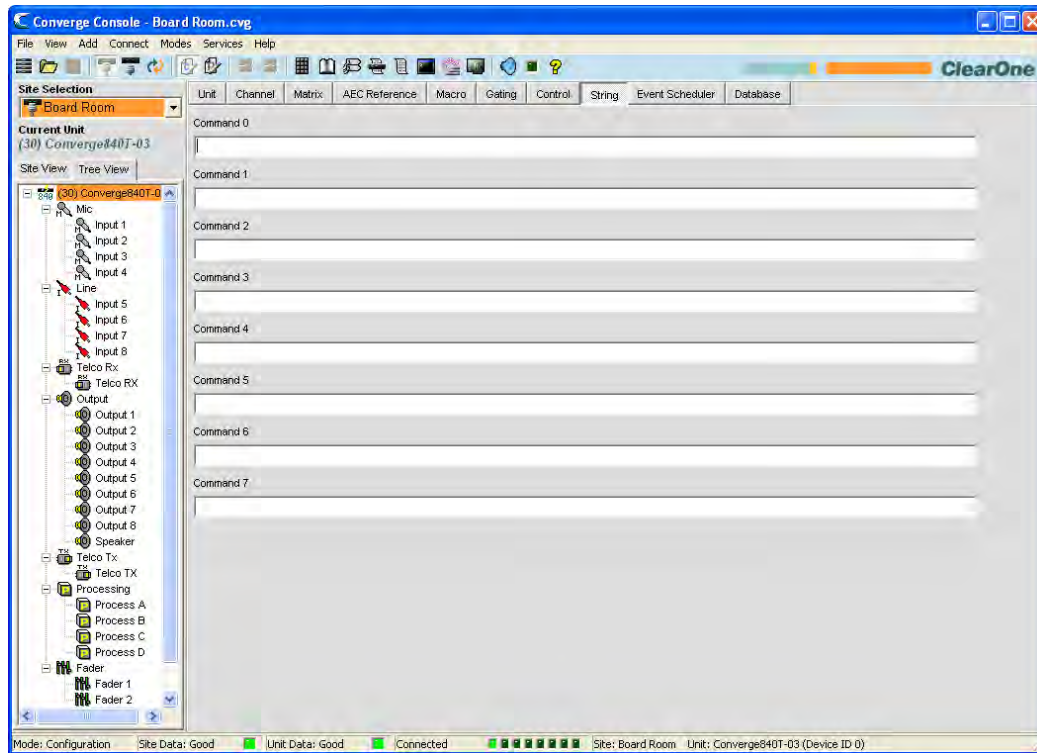

You can create up to eight serial command strings (limit 80 characters each) on the String screen. The following sections explain how to create and run command strings.

Command String Special Characters

The following character combinations provide basic functionality in Command String syntax:

- **\a** = alert
- **\b** = backspace
- **\f** = form feed
- **\n** = new line
- **\r** = carriage return
- **\t** = horizontal tab
- **\v** = vertical tab
- **** = backslash

Creating Command Strings

Type a command string in the **Command 0** through **Command 7** text boxes in the center pane of the **Control Tab**. Alternatively, you can copy an existing string from any source, then right-click in a **Command** entry box and select **Paste** from the shortcut menu that appears.

Running Command Strings

Console stores the commands strings created in the Control tab for subsequent execution via the **STRING** serial command. You can execute the **STRING** command in macros, using control pin programming, in the Event Scheduler, and from the Control Console page of the Web Builder tab. Using macros also enables you to execute command strings from external control devices. See the *Control Tab* topic for more information.

For additional information, refer to the *Table of Contents* for these related topics:

- **Controls and Connections**
- **Front Panel**
- **Control/Status Port**
- **Gating Tab**
- **Macro Tab**
- **Event Scheduler**
- **Control Tab**

EVENT SCHEDULER TAB

The **Event Scheduler** allows you to schedule commands for execution at a specific time (events). Using the event scheduler, you can schedule single events or recurring events that are executed at pre-defined time intervals.

Accessing the Event Scheduler

To schedule events, press the **Event Scheduler Tab** on the **Tab Bar** in Console.

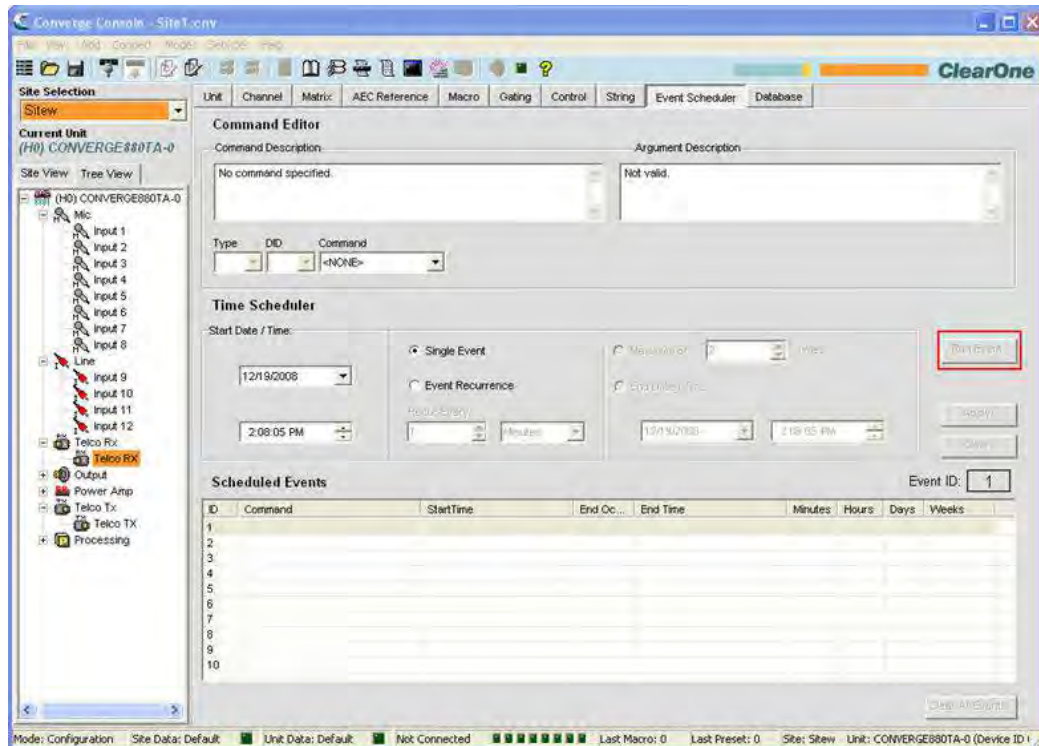

Scheduling Events

Events must be scheduled and run on the local device. However, commands can be sent from events to other devices in the site using Macros.

Use the following procedure to schedule events:

1. In the **Command Editor** section of the screen, select command from the **Command** drop-down list. The command description appears in the **Command Description** box, parameters appear next to the **Command** drop-down list, and the valid values for each parameter appear in the **Argument Description** box.



The commands available for event scheduling include:

- **MACRO** –Executes a macro
- **PRESET** –Executes a preset
- **RESET** –Resets the specified device
- **SFTYMUTE** –Mutes all channels on the specified unit
- **STRING** –Runs a command string
- **SYSCHECKS** –Runs system diagnostics

2. To schedule a single event, select **Single Event** and set the desired **Start Date/Time** in the **Time Scheduler** section of the screen.

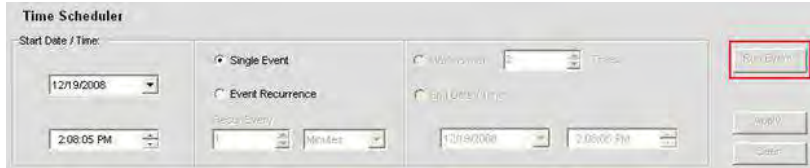

3. To schedule a recurring event, select **Event Recurrence**; set the recurrence interval using the **Recur Every** fields; and select either **Maximum of Times** or **End Date/Time** to specify the number of repetitions or time period for event execution respectively.

NOTE: Clicking on the arrow button next to a date entry field in the **Time Scheduler** section of the screen displays a calendar for date selection.

4. Click the **Apply** button to schedule the event. The event appears in the Scheduled Events List.

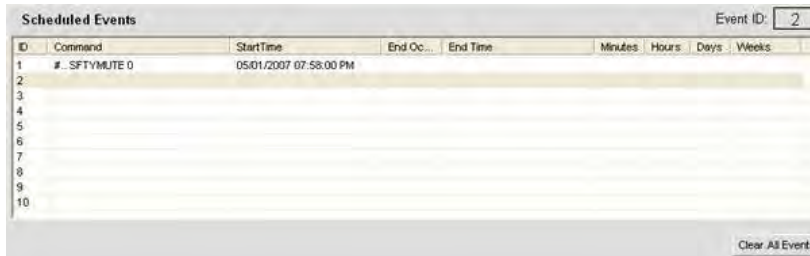

ID	Command	StartTime	End Oc...	End Time	Minutes	Hours	Days	Weeks
1	#...SFTYMUTE 0	05:01:2007 07:58:00 PM						
2								
3								
4								
5								
6								
7								
8								
9								
10								

5. Add additional events as required by repeating steps 1 through 4.
6. To clear a single event, highlight the event and press **Clear**. To clear all scheduled events, press the **Clear All Events** button. Answer **Yes** in the **Warning** dialog that appears.

NOTE: Events can also be viewed and scheduled via the Management page of the Web Portal.

For additional information, refer to the *Table of Contents* for these related topics:

- **Macro Tab**
- **Preset Mode Overview**
- **Safety Mute**
- **String Tab**
- **System Checks**
- **Web Builder**

DATABASE TAB

NOTE: Objects and Devices created in Console 1.0.4 and 1.1.5 are NOT compatible with Console 2.0+ Objects and devices created with these earlier versions will need to be re-created. **Databases created with the 2.0.x release are compatible with subsequent releases.**

The **Database Tab** enables you to create, modify, and save AV devices, channel objects, and advanced objects. AV devices allow you to save pre-defined configurations for a particular type of device, such as a ceiling microphone. Channel objects allow you to save pre-defined configurations for a channel. Advanced objects allow you to save matrix, macro, control, and preset objects for advanced configuration and automation tasks.

Using AV devices and channel objects, you can create standardized configurations for particular room types and equipment, and quickly configure a venue. See *Drag & Drop Configuration* for more information.

Accessing the Database

To access the Database, select the **Database Tab** from the **Tab Bar** in Console.

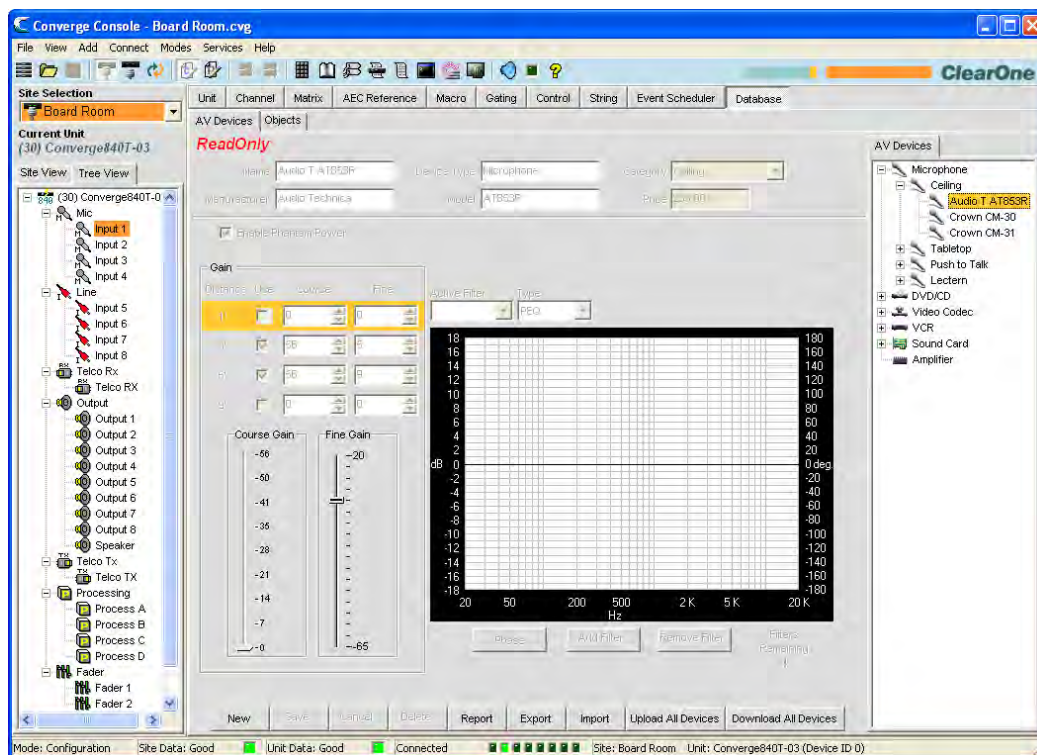

As shown above, there are two tabs available in the center pane: **AV Devices** and **Objects**. A corresponding tab is displayed in the **Object Pane** on the right side of the screen. The **Database Button Bar** is located at the bottom of the Center Panel. These components are described in the following sections.

NOTE: Advanced object types are not viewable in the Database Tab

Database Button Bar

The Database Button Bar (shown below) allows you to create, save, delete, export, import, upload, and download AV Devices and Objects. Buttons available change based on the device/object selected and the status of the configuration screen displayed in the center pane.



Click the **Report** button to view and print a report of all AV devices.

AV Devices

AV devices allow you to save pre-defined configurations for a particular type of device, such as a ceiling microphone. To access AV devices, expand the **AV Device Tree** in the **AV Devices Tab** in the **Object Pane** on the right side of Console. Click on a device in the tree to display its configuration in the center pane. For example, the default settings for a ClearOne tabletop microphone are shown below.

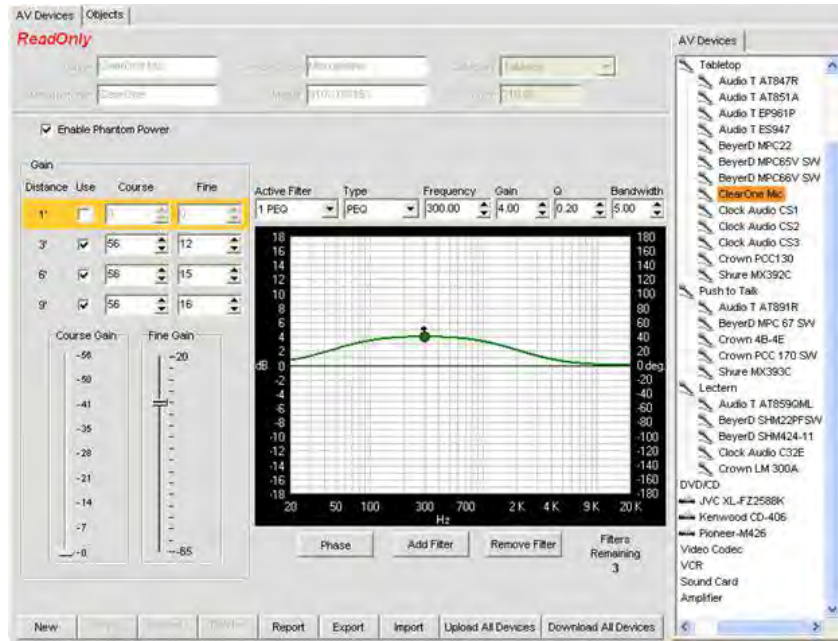

NOTE: Pre-defined AV devices created by ClearOne are **ReadOnly** as indicated in the center pane. They cannot be modified or deleted.

Creating A New AV Device

To create a new AV device, select the type of device you want to create in the **AV Devices Tree**, then click the **New** button on the **Database Button Bar**. The configuration options for that type of device appear on the **AV Devices Tab** in the **Center Pane**. For example, the configuration options for a new Video Codec device are shown below.



Name the new device using the **Name** field. Enter other information as needed, adjust the configuration controls to optimize device performance, and click the **Save** button to save the changes.

The new device now appears in the **AV Device Tree** as shown below.

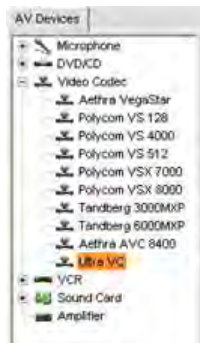

NOTE: The AV Device Tree is also available when the Unit Tab is selected, making all pre-defined and custom AV Devices available for Drag and Drop Configuration of a venue.

Channel Objects

Channel objects allow you to save pre-defined configurations for a channel, such as an Output channel. To access objects, select the **Objects** tab in the **center pane**. The **Object Tree** appears in the **Object Pane** on the right side of the screen as shown below.

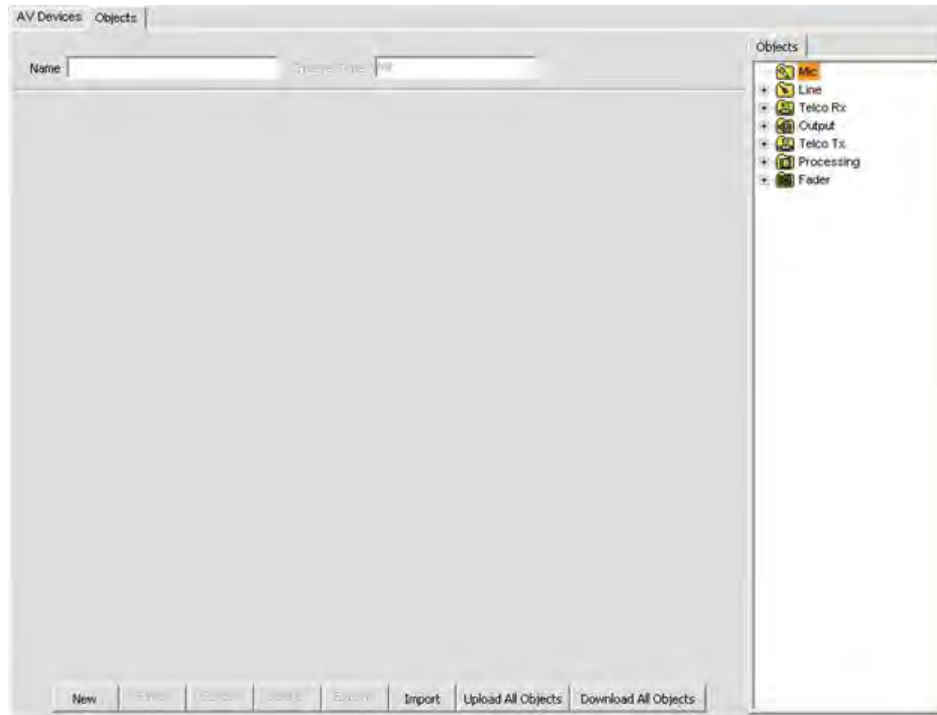

Available channel object types include:

- **Mic Input**
- **Line Input**
- **Telco/VoIP Rx**
- **Output**
- **Telco/VoIP Tx**
- **Processing**
- **Fader Channels**

To create a new channel object, select an object type in the **Object Tree** and click the **New** button. Enter a name for the object in the **Name** field, adjust the channel configuration controls to optimize channel performance for your application, and press the **Save** button. The new channel object appears in the **Object Tree**, along with all other custom channel objects you have created, as shown below.

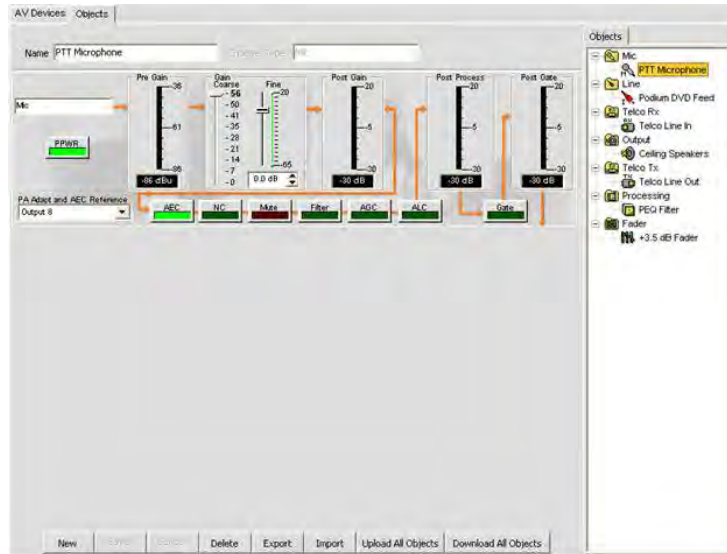

NOTE: The Object Tree is also available when either the Unit Tab or the Channel Tab is selected, making all custom channel objects you have defined available for Drag and Drop Configuration of a venue.

Import/Export AV Devices and Objects

All AV Devices and channel Objects are stored as **.XPT files** and **.XMO** files respectively on the host computer or network. To import or export these files, use the **Import** and **Export** buttons on the **Database Button Bar**. These features enable you to share device and object file definitions across sites, applications, and venues.

Upload/Download AV Devices and Objects

To upload or download ALL AV Devices or channel Objects in the database, use the **Upload** and **Download** buttons on the Database Button Bar. These features enable you to share databases among sites, applications, and venues.

Modifying AV Devices and Objects

To modify AV Devices and channel Objects, select the device or object in the **Object Pane**, modify the configuration settings for the device or object in the **Center Pane**, and click the **Save** button on the **Database Button Bar**. When you make changes to the device or object, **Edit** appears at the top of the Center Pane.

NOTE: Pre-defined AV devices created by ClearOne are **ReadOnly** as indicated in the center pane. They cannot be modified or deleted.

For additional information, refer to the *Table of Contents* for these related topics:

- **Site Properties**
- **Unit Properties**
- **Unit Tab**
- **Channel Tab Overview**
- **Line Input Settings**
- **Mic Input Settings**
- **Telco/VoIP Rx Settings**
- **Output Settings**
- **Telco/VoIP Tx Settings**
- **Processing Settings**
- **Fader Settings**
- **Matrix Tab**
- **Preset Mode Overview**

OPTIMIZING GAIN STRUCTURE

Optimizing Gain Structure maximizes the signal-to-noise ratio for each channel, optimizes the performance of processing functions, and ensures optimal audio quality.

Use these guidelines when optimizing initial gain structure for a venue:

- Connect all input sources and output devices to the CONVERGE/CONVERGE Pro unit(s).
- Turn off all processing functions, including **AGC/ALC (Automatic Gain Control/Automatic Level Control)**, **NC (Noise Cancellation)**, and **Filters**.
- Optimize all mic and line inputs that are routed to an output before optimizing the output.
- When optimizing output channels, the objective is to match the output to the nominal gain of the input of the device that is connected to the output channel.
- In general, turn NOM off when an output channel feeds an amplifier. Turn NOM on when optimizing Telco/VoIP Tx channels, in sound reinforcement applications, and when optimizing for video codec configurations.
- After optimizing gain using the procedures below, re-enable processing functions and NOM as required.

Optimizing Gain for Mic Input Channels

1. Open the **Channel Tab** and select the **Mic Input** on the **Tree View Tab** that you want to optimize, as shown below.

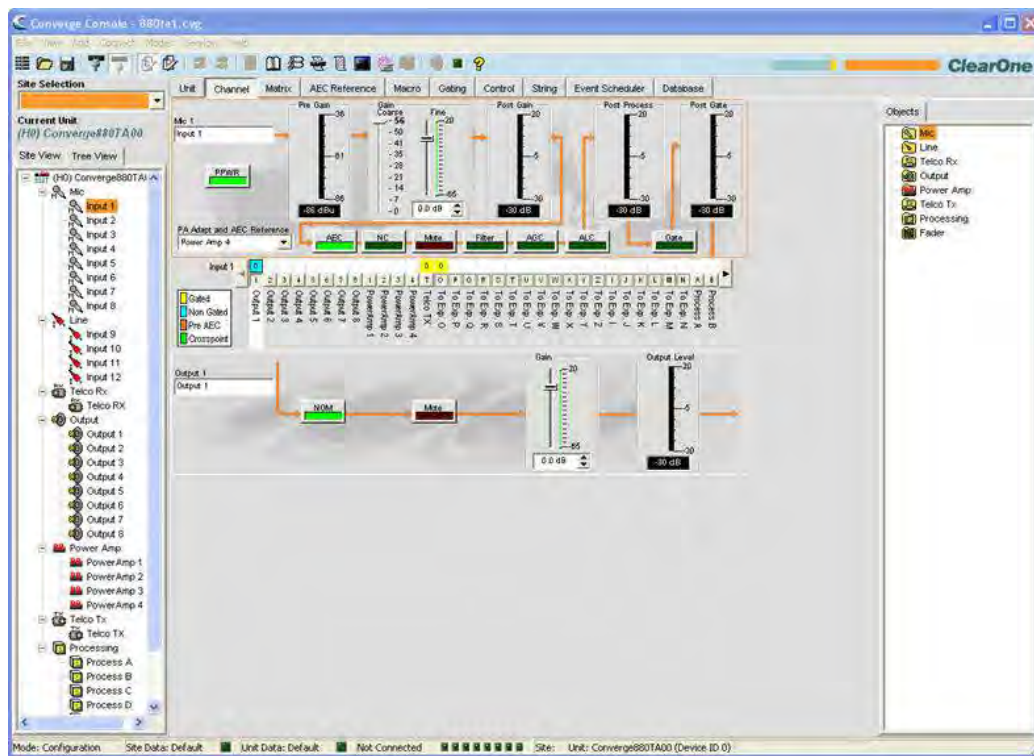

2. Have somebody repeat a test count at a normal distance from the microphone (generally this would be seated at the conference table or positioned for a video teleconference).
3. Adjust the **Coarse Gain Slider** until the peaks on the **Post Gain Meter** are close to +6dB (just hitting yellow), and the average level is close to 0dB.
4. Adjust the **Fine Gain Slider** until the peaks on the **Post Gain Meter** are as close to +6dB and the average level is as close to 0dB as possible.
5. Repeat the above steps for each mic input in the venue.

NOTE: The Post Gain Meter is a peak meter. If the meter remains green, the level may be too low. If it peaks into red, clipping occurs.

Optimizing Gain for Line Input Channels

Line inputs are optimized using the same procedure as mic inputs, with the following exceptions. Select the **Line Input** you want to optimize on the **Tree View Tab**. With the line source connected, monitor the **Post Gain Meter** and adjust the gain level.

NOTE: Line sources, including video codecs, consumer grade CD players, DVD players and VCRs, commonly require 10-12 dB of gain to bring their levels up to 0 dBu.

Optimizing Gain for Telco/VoIP Rx Channels

Optimize Telco/VoIP Rx inputs using the same procedure as mic inputs, with the following exceptions. Select **Telco/VoIP Rx** on the **Tree View Tab**. With someone talking on the phone, monitor the **Post-Gain Meter** and adjust the gain level.

Optimizing Gain for Telco/VoIP Tx Channels

Optimize Telco/VoIP Tx outputs using the same procedure as output channels, with the following exceptions. Select **Telco/VoIP Tx** on the **Tree View Tab**. With someone speaking into the microphones routed to the Telco/VoIP Tx, monitor the **Post Gain Meter** and adjust the gain level.

NOTE: Use a standard handset on the far end because levels can be unpredictable from speaker phones and amplified headsets.

Optimizing Gain for Output Channels

1. Open the **Channel Tab** and select the **Output Channel** on the **Tree View Tab** that you want to optimize, as shown below.

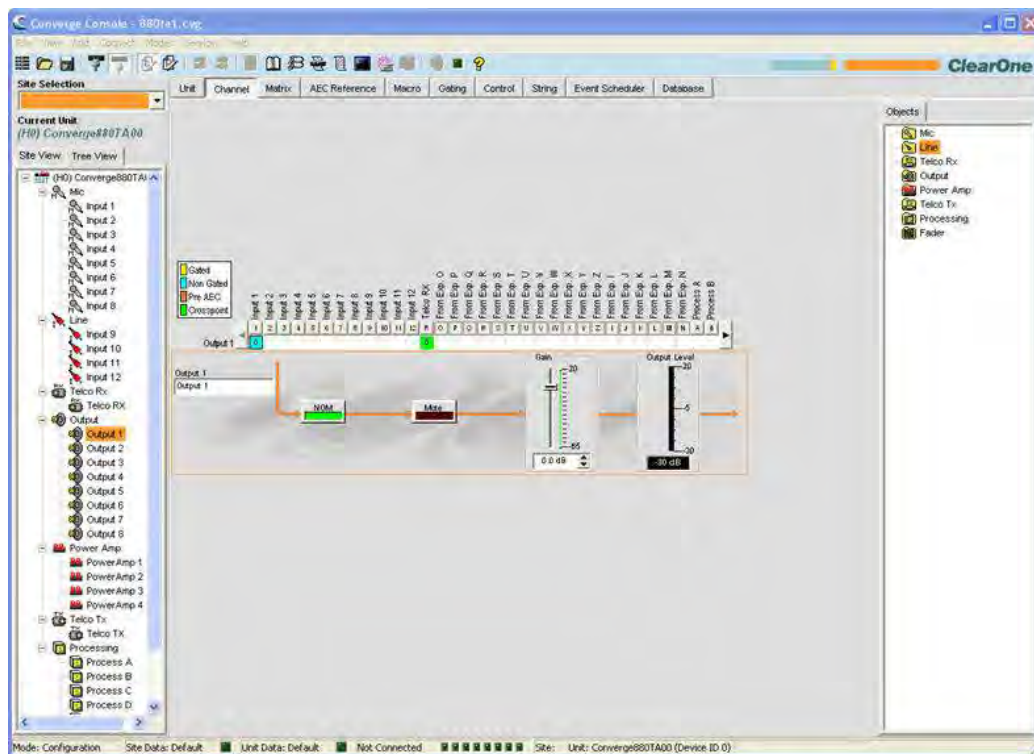

2. Optimize the gain level for all mic, line, and Telco/VoIP Rx inputs routed to the selected output channel.
3. Adjust the **Gain Slider** until the average level on the **Gain Meter** matches the nominal level of the next device in the chain.
4. Repeat the above steps for each output channel in the system.

For additional information, refer to the *Table of Contents* for these related topics:

- **Configuration Mode Overview**
- **Mic Input Settings**
- **Line Input Settings**
- **Telco/VoIP Rx Settings**
- **Telco/VoIP Tx Settings**
- **Output Settings**
- **AEC (Acoustic Echo Cancellation)**
- **AGC/ALC (Automatic Gain Control/Automatic Level Control)**
- **NC (Noise Cancellation)**
- **Filters**

DRAG AND DROP CONFIGURATION

NOTE: Objects and Devices created in Console 1.0.4 and 1.1.5 are NOT compatible with Console 2.0+ Objects and devices created with these earlier versions will need to be re-created.

Console provides powerful **Drag and Drop Configuration** capabilities that allow you to quickly configure CONVERGE/CONVERGE Pro devices and perform advanced system configuration tasks.

The types of objects available in Console for drag and drop configuration include:

- AV Devices
- Channel Objects
- Matrix Objects
- Control Objects
- Macro Objects
- Preset Objects

Accessing Drag and Drop Configuration

To select objects for drag and drop configuration, use the **Objects Pane** on the right side of Console. The objects available in the objects pane vary depending on the tab selected on the Console **Tab Bar**. For example, when the **Unit Tab** is selected, both AV devices and channel objects are available as shown below.

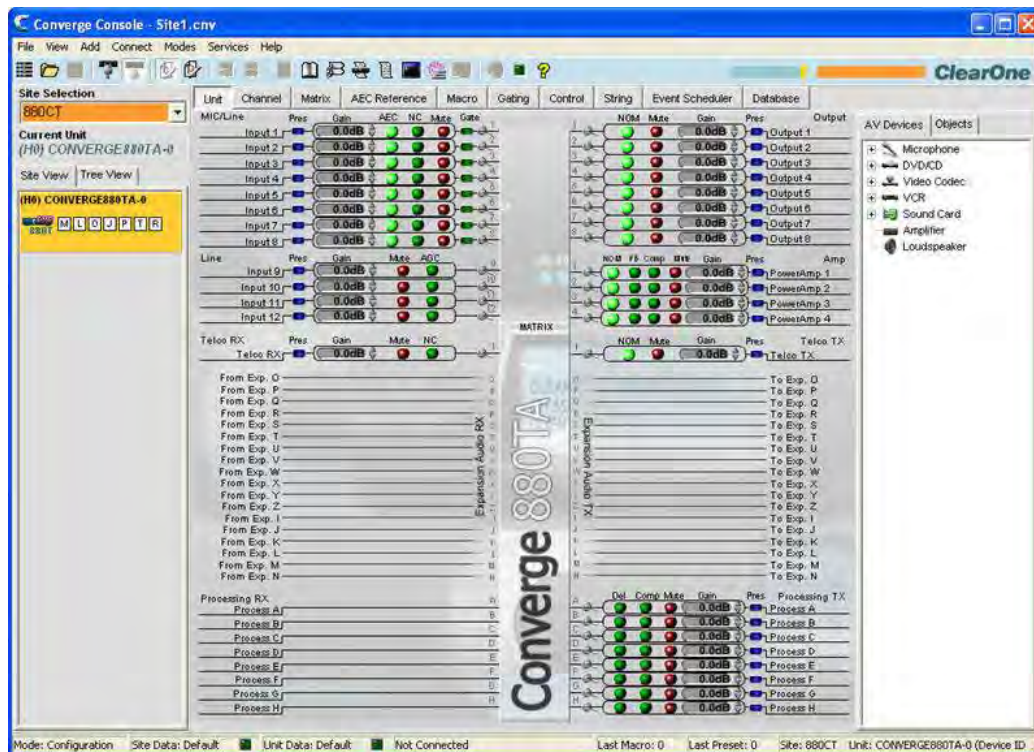

Using Drag and Drop Configuration

Drag and drop configuration is a three step process for all object types:

1. Create an object
2. Store it in the Database
3. Drag the object from the Objects pane onto a channel or screen area (as appropriate for the object type)

The following sections describe creating and applying objects in Console.

Creating Objects

With the exception of custom AV devices, which can only be created using the **Database Tab**, all objects can be created by right clicking on a screen and using the shortcut menu that appears.

For example, to capture the currently displayed control pin programming as a control port object, right click in the **Control/Status Pin Select** portion of the of the **Control Tab** screen, and select **Export as object** from the shortcut menu (see below).

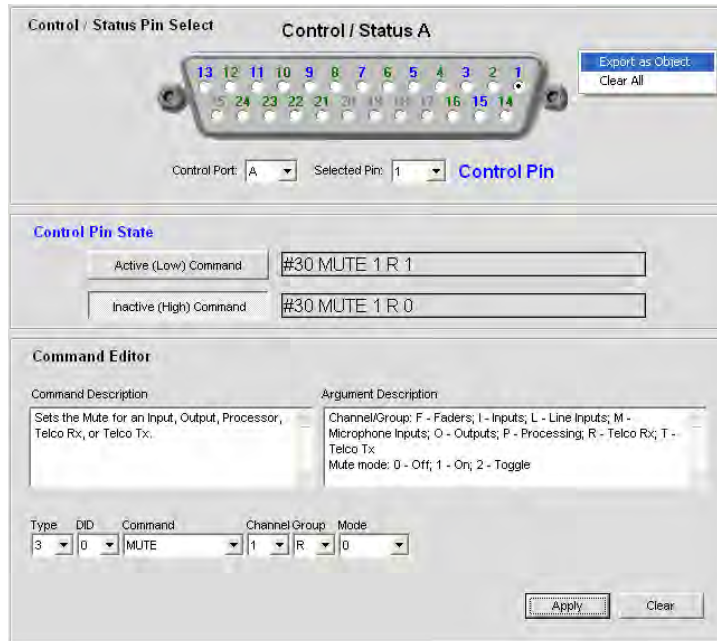

The **Export Object** dialog appears as shown below. Assign the object a name and press **Export**.

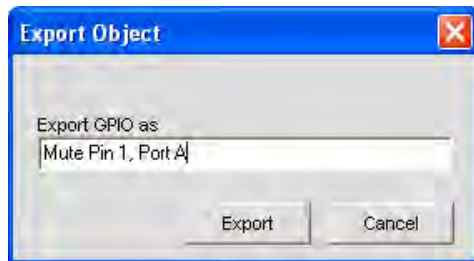

The control object now appears in the objects pane as shown below.

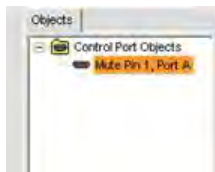

The object is now available for drag and drop configuration.

AV Devices

ClearOne provides numerous pre-configured AV devices, with settings that optimize the performance of the device for a typical (baseline) room. These devices are available in the **AV Devices** tab of the **Objects Pane** as shown below. Click a device type in the **AV Device Tree** to show the available devices of that type.

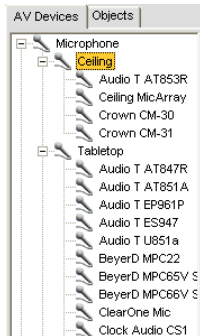

To apply an AV device to a channel, drag the object onto the channel in the **Unit** or **Channel** tabs. For example, to apply a ClearOne **Ceiling Microphone Array** to **Mic/Line Input 1**, select the object from the **AV Devices** tree and drag it onto the input channel.

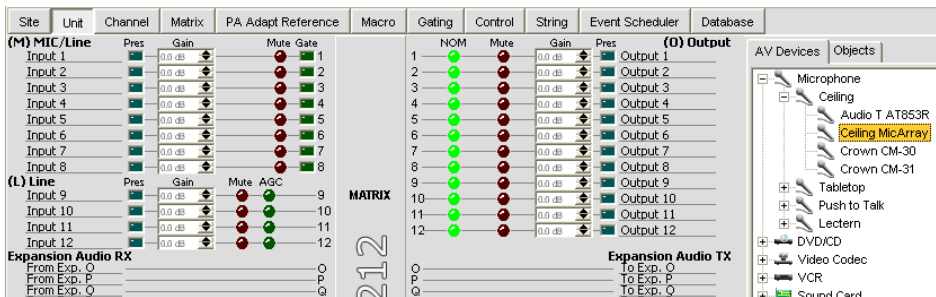

A dialog prompts you for the distance of the microphone to the talker. Select a value and press **OK** to apply the object to the channel.



A microphone icon appears next to the channel, indicating that the channel is using an AV device object configuration.

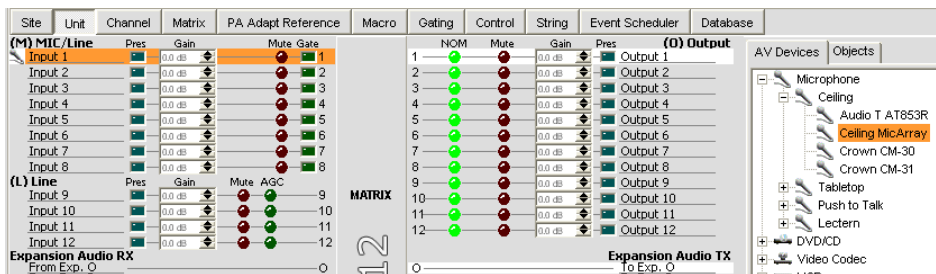

Click on the microphone icon to view object properties and enter a serial number in the **AV Devices Properties** dialog.

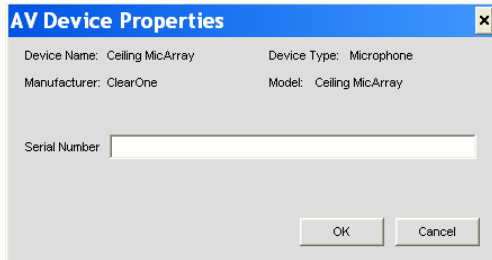

To view detailed information about an AV device's configuration settings, or to create a custom AV device, use the **AV Devices** pane of the **Database** tab.

Channel Objects

In addition to using AV devices, you can drag and drop **Channel Objects** in the **Unit Tab** and the **Channel Tab** to instantly apply a saved configuration to a channel. These objects include the ClearOne line of wireless microphones, which can be dragged and dropped onto an input.

NOTE: When Objects are dragged and dropped, an icon appears beside the channel. An icon does not appear for the wireless microphone objects, but configuration is still possible.

When a Channel Object is used and as an input, for example on **Input 1** on the **Channel** tab, you can configure the settings for **wireless mic** as shown below.

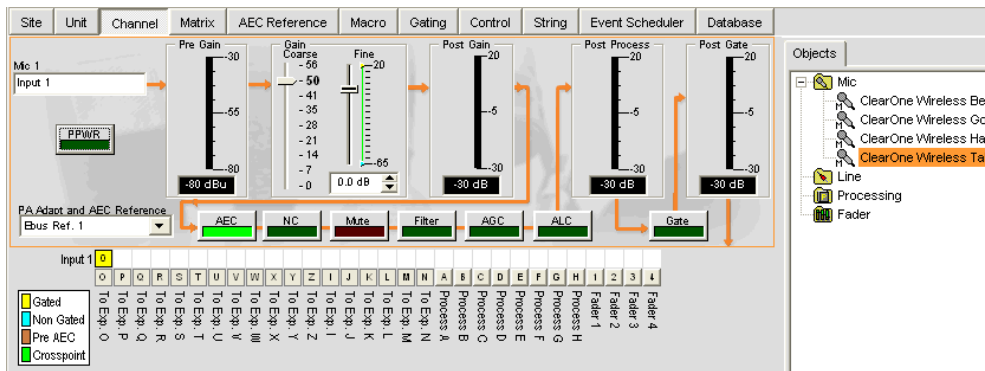

When a Channel Object is used and as an output on **Output 1** on the **Channel** tab, for example, you can configure NOM, mute, and gain settings for **Output 1** on the **Channel** tab as shown below.

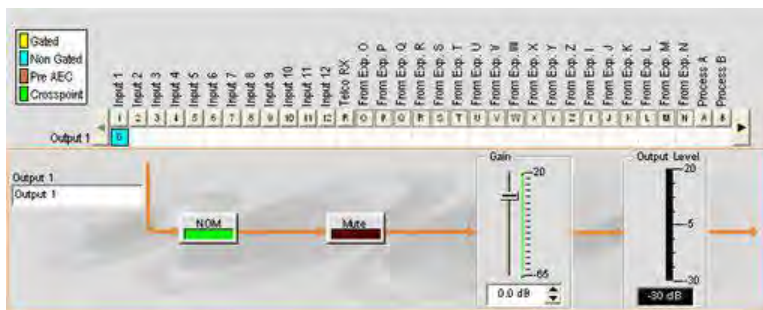

You can save channel objects for all CONVERGE channel types, including **Mic Input, Line Input, Telco/VoIP Rx, Telco/VoIP Tx, Output, Processing, and Fader** channels. To save the object, right click anywhere in the signal flow diagram and select **Export as Object** from the shortcut menu. Enter a descriptive object name in the **Export Object** dialog, and click **Export** to save the object to the database.

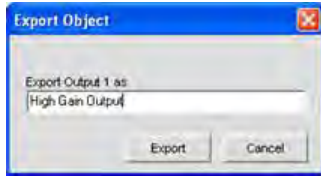

The object now appears in the **Objects** pane.



You can now drag and drop the object onto any channel of the same type to instantly apply the object's configuration settings to the channel.

NOTE: To apply the current channel settings to ALL channels of the same type without saving an object in the database, select **Apply to all** from the shortcut menu when right-clicking on the signal flow diagram. (Menu option not available for Telco/VoIP Rx or Telco/VoIP Tx channels.)

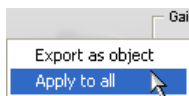

To view detailed information about an AV device's configuration settings, or to create a custom AV device, use the **AV Devices** pane of the **Database tab**.

Advanced Configuration Objects

For advanced configuration tasks, Console allows you to create and apply **Matrix Objects**, **Control Objects**, **Macro Objects**, and **Preset Objects** as described in the following sections.

Matrix Objects

Matrix Objects allow you to save customized matrix configurations into the **Database** and reuse them. This enables you to instantly re-configure the entire matrix to accommodate changes in conferencing or venue configuration requirements, and to rapidly configure additional units using drag and drop configuration.

To capture the current matrix configuration and save it as a matrix object, right click anywhere in the center pane of the matrix screen and select **Export as Object** from the shortcut menu.

To apply a matrix object, drag it from the **Objects Pane** and drop it onto the matrix in the **Matrix Tab** screen.

Control Objects

Control Objects allow you to save control port objects into the **Database**. To capture the currently displayed control pin programming, right click in the **Control/Status Pin Select** portion of the **Control Tab** screen, and select **Export as Object** from the shortcut menu. After saving the control port object, it appears in the **Objects** pane on the right side of Console.

To apply a control object after saving it to the database, drag it from the **Objects Pane** and drop it onto the **Control/Status Pin Select** portion of the **Control Tab** screen.

Macro Objects

Macro Objects allow you to save macros into the **Database** and reuse them. To capture a macro and save it as an object, right click anywhere in the center pane of the macro screen and select **Export as object** from the shortcut menu. After saving a macro as an object, it appears in the **Objects** pane on the right side of Console.

To use a macro object, drag it from the **Objects Pane** and drop it onto the **Macro Command List** portion of the **Macro Tab** screen.

Preset Objects

Preset Objects allow you to save preset configurations into the **Database** and reuse them. This enables you to instantly apply preset changes, and to rapidly configure additional units using drag and drop configuration.

To capture the current preset and save it as an object, right click anywhere in the center pane of the preset screen and select **Export as Object** from the shortcut menu.

To apply a preset object, drag it from the **Objects Pane** and drop it onto the **Site Pane** of Console while in Console is in **Preset Mode**.

For additional information, refer to the *Table of Contents* for these related topics:

- **Database Tab**
- **Mic Input Settings**
- **Line Input Settings**
- **Telco/VoIP Rx Settings**
- **Telco/VoIP Tx Settings**
- **Output Settings**
- **Processing Settings**
- **Fader Settings**
- **Matrix Tab**
- **Control Tab**
- **Macro Tab**
- **Preset Mode Overview**

PRESET MODE

Preset Mode allows you to create and modify presets. To execute presets, Console must be in Configuration Mode. There are 32 presets available in Console.

Presets provide the configuration flexibility needed to meet the challenges of changing conference room requirements. These changes include audio routing, gating, muting, levels, AEC referencing, and signal processing, as well as room combining and room configuration. Presets allow you to make configuration changes instantaneously—without interrupting or affecting any conferences in progress.

This topic covers:

- **Preset Configuration Tabs**
- **Creating Presets**
- **Executing Presets**
- **Preset Execution Flags**
- **Preset Control Masking**
- **Preset Storage Space Considerations**
- **Exporting Preset Objects**

Accessing Preset Mode

To access Preset Mode, press the **Preset**  button on the Console **Button Bar**, or select **Preset** from the **Modes** menu.

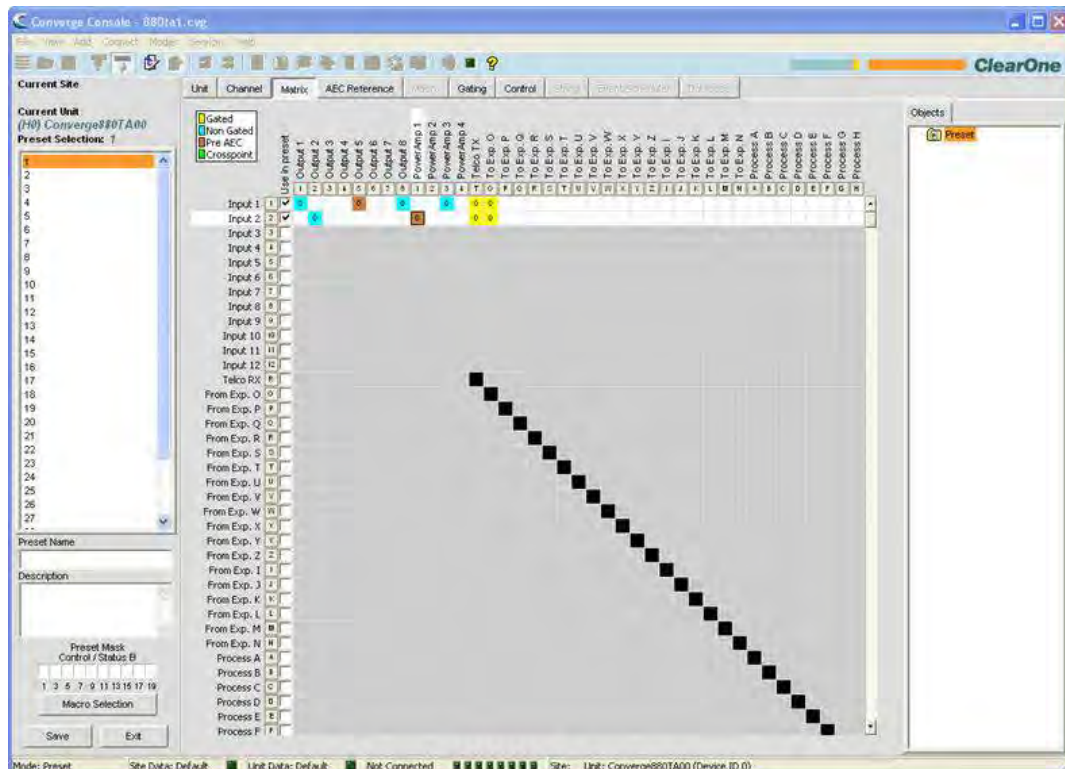

As shown above, Console displays the Matrix tab by default in Preset Mode (rather than the Unit tab that is the default in Configuration Mode). The **Site Pane** also changes to display the **Current Site**, **Current Unit**, **Preset Selection** list and the **Preset Name**, **Description**, and **Preset Mask** entry fields.

NOTE: Clicking a channel label in the matrix displays the Channel tab for the channel. Right-clicking anywhere in the matrix displays a shortcut menu that allows you to set a cross point, copy a cell, copy the matrix, paste a matrix, and clear the matrix.

Preset Configuration Tabs

In preset mode, the following tabs are available on the Console **Tab Bar** for defining preset configurations:

- **Unit Tab**
- **Channel Tab**
- **Matrix Tab**
- **AEC Reference/PA Adapt Reference Tab**
- **Gating Tab**
- **Control Tab**

The channels available for configuration in a preset are determined by the channels selected in the **Use in preset** row on the matrix tab. Rows that are not selected in the matrix are grayed out, making them unavailable for preset configuration changes. In addition, only output channels that have a cross point set in the matrix tab will be available in the preset.

When you click a check box in the **Use in preset** row, the row becomes active and you can change its routing, gating, AEC/PA Adapt reference, and other settings. All changes will be saved in the preset and executed when the preset is ran. Channels that are not selected remain unchanged after preset execution.

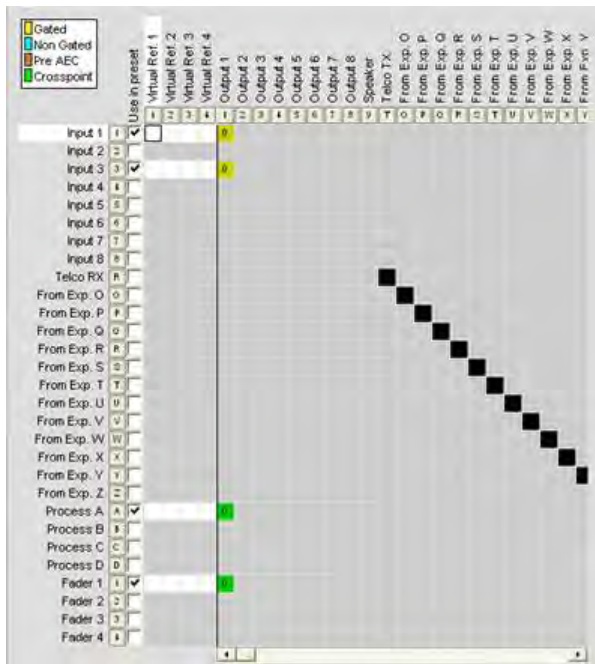

In the example above, Input 1 and Input 3 are selected for use in the preset, and routed to Output 1 with gating enabled and a cross point level adjustment of zero. Cross points are also set for Output 1 on the Process A and Fader 1 channels.

For AEC/PA Adapt reference changes in a preset, you can also select channels in the **Use in preset** row as shown below. (Note that only the channels selected and cross pointed in the matrix are available, and that they are selected by default.)

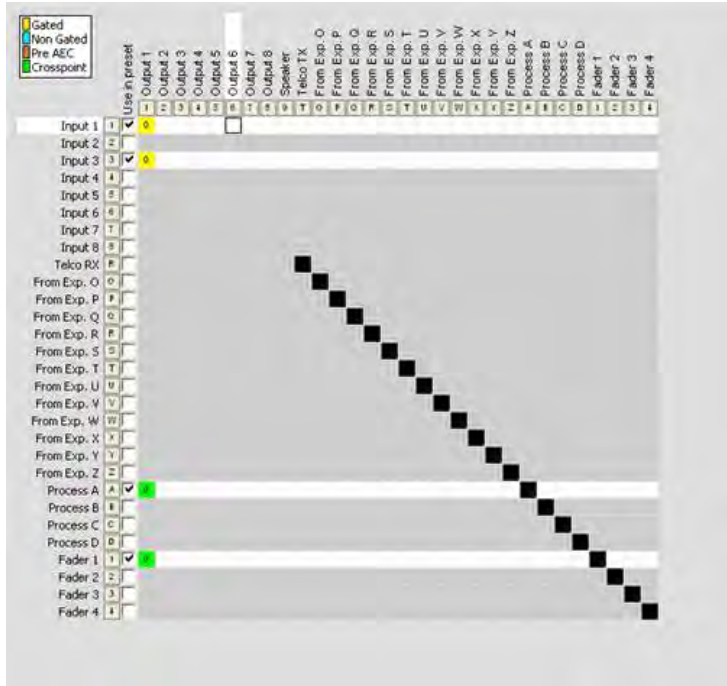

Creating Presets

Use the following procedure to create presets:

1. Press the **Preset Mode** button on the Button Bar to put Console into preset mode.



2. Select the number of the preset you want to configure in the **Preset Selection** list.



3. Enter a **Preset Name** and **Description** in the entry fields (optional).

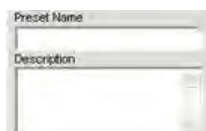

4. Select the channels you want to include in the preset using the **Use in preset** check boxes in the matrix.

- Set the output channel cross points that you want to include in the preset using the matrix.

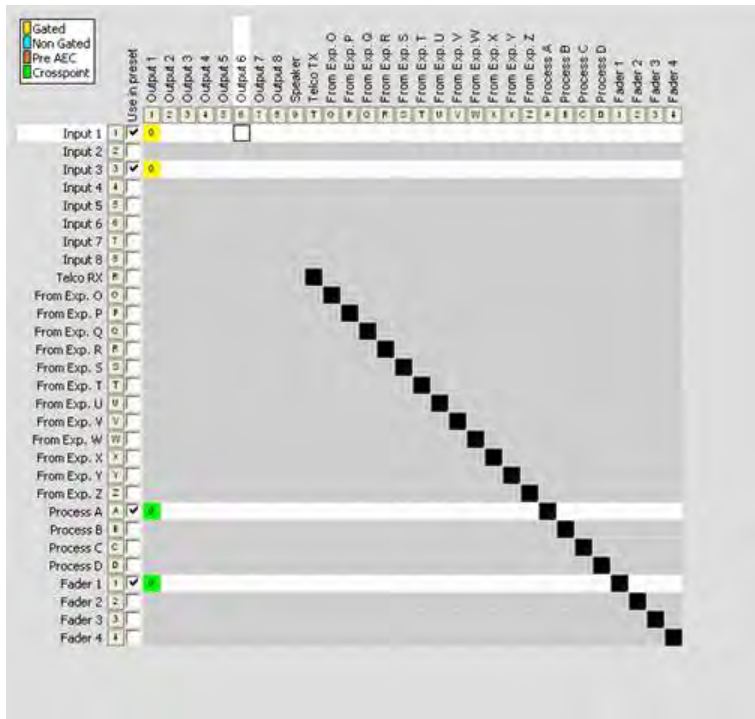

- Configure the desired setting changes for the preset including:
 - Mic Input, Line Input, Output, Telco/VoIP Rx, Telco/VoIP Tx, Processing, and Fader channel settings
 - Gating settings
 - Control settings
 - AEC/PA Adapt Reference settings
- Click on the **Preset Mask Control/Status B** boxes to set the pin states (H = High, L = Low) required to trigger preset execution (optional). See Preset Control Masking for more information.



- Press the **Macro Selection** button to execute one or more macros when the preset executes (optional).

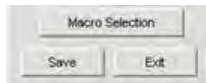

NOTE: In most cases, macros should not be used in a preset unless you want to run a serial command. Some examples that require a macro include querying device status when a preset executes, and sending a command string to an external control device to indicate preset/room configuration status. Also, macros execute at the end of a preset after all other routing, level, and configuration changes included in the preset are completed.

- Press the **Save** button to save the preset
- Click the **Exit** button to exit preset mode and return to configuration mode.

The preset is now available for execution as described below.

Executing Presets

There are five ways to execute presets:

1. Using Console in Configuration Mode
2. Using the LCD Preset Menu on the Front Panel
3. Using control programming and external control devices (such as the closure contacts on a room partition)
4. Using macros
5. Using serial commands via a Telnet session or via RS-232

NOTE: Presets only run on the current unit shown in the site pane. However, you can execute a preset on a unit connected to the Expansion Bus by using a macro.

Executing Presets Using Console

Select **Execute Preset** from the **Services** menu, or press the Execute Preset  button on the button bar. Select the preset you want to execute from the **Execute Preset** dialog that appears, and press the **Execute** button.



NOTE: When executing presets in Console, the software assumes a preset execution flag value of 2, meaning that the preset executes and its execution state is set to off.

Executing Presets Using the LCD Preset Menu

Press the **Select** button on the front panel, use the **Menu Dial** to select **Presets**, and press the **Select** button.

The **Preset Menu** appears as shown below:



NOTE: When executing presets from the LCD Preset menu, Console assumes a preset execution flag value of 2, meaning that the preset executes and its execution state is set to off.

Use the following procedure to execute presets from the front panel LCD display:

1. Use the **Menu Dial** to highlight the preset you want to execute
2. Press the **Select** button
3. Answer **Yes** at the prompt that appears to run the selected preset, or **No** to cancel.

Executing Presets Using Control Programming

Use the **PRESET** serial command in the **Active (Low) Command** or **Inactive (High) Command** fields in the **Control Pin State** section of the Control Tab. To execute multiple presets when a control condition is met, use the **MACRO** command to call a macro with multiple **PRESET** commands embedded, as explained in the next section.

For more information on **PRESET** and the complete **CONVERGE/CONVERGE Pro** serial command set, refer to *Appendix A: Serial Commands*.

Executing Presets Using Macros

Use the **PRESET** serial command to execute presets in a macro. To run multiple presets at the same time, use multiple **PRESET** commands in the macro. Macros can be executed from within Console or by using any external control device. Typically, you will create a macro for each room configuration (group of presets) that you want to execute at the same time.

Preset Execution Flags

Console uses user-selectable preset flags to determine the current execution state of a preset. This gives you complete control over preset execution, and allows you to combine multiple presets in a macro (or multiple macros) while ensuring that only the presets required for a given room configuration are executed when needed.

The three user-selectable execution flags are:

- 0 = Do not execute the preset and set the execution state to **off**.
- 1 = Check Preset state. If **off**, execute preset and set Flag to **on**. If **on** do nothing.
- 2 = Ignore execution state. Execute the preset and set the execution state to **off**.

When an execution flag is set to **on**, the associated preset cannot be executed. Conversely, when it is set to **off**, the preset can be executed. To query the current execution flag state for a preset, use the **PRESET** command with the preset number and no other arguments.

Preset Control Masking

In traditional room-combining applications, one preset is created and executed for each room configuration. This can cause volume levels, mute states, and other channel configuration settings to reset for all room sections when a preset is executed. In addition, conferences in progress in unaffected room sections lose any custom settings, and the participants hear unnecessary pops and clicks.

Console eliminates these shortcomings through **Preset Control Masking**, which provides the following advantages:

- Automatic preset masking control when room dividers are wired to **Control** port B pins
- Manual preset masking control via serial commands
- Volume levels and mute states are reset only in sections that change
- Unaffected room sections do not lose custom settings
- Participants in unaffected room sections do not hear pops and clicks

To use preset control masking, click on the **Preset Mask Control/Status B** boxes (located in the **Site Pane** while Console is in preset mode) to set the pin states (**H** = High, **L** = Low) required to trigger preset execution. You can use a pin state or combination of pin states to define when a preset will execute.



A typical use for preset masking is a room-combining application that uses automatic partitions with sensors that set the pin to high when a partition is open, and to low when a partition is closed. For example, if **Pin 1** is connected to a first partition and **Pin 3** is connected to a second partition, then the preset mask control/status B settings shown above would activate the preset when the first partition is open and the second partition is closed.

Preset Storage Space Considerations

In most preset configuration scenarios, it is unlikely that you would reach the storage capacity of a CONVERGE/ CONVERGE Pro unit. In the event that you exceed the preset storage space, Console will alert you when you try to save the preset. You will be asked to reduce the number of cross point changes in the **Matrix**, or reduce the number of **Macros** in the preset. As a general rule, you make cross point changes to three-fourths of the matrix with up to two macros in a given preset; **OR** you can use up to 255 nested macros for a given preset.

Exporting Preset Objects

Preset objects allow you to save preset configurations into the **Database** and reuse them. This enables you to instantly apply preset changes, and to rapidly configure additional units using drag and drop configuration.

To capture the current preset and save it as an object, right click anywhere in the center pane of the preset screen and select **Export as object** from the shortcut menu.

To apply a preset object, drag it from the **Objects Pane** and drop it onto the **Site Pane** of Console while in Console is in **Preset Mode**.

For additional information, refer to the *Table of Contents* for these related topics:

- **Configuration Mode**
- **LCD Presets Menu**
- **Controls and Connections**
- **Expansion Bus Overview**
- **Unit Tab**
- **Channel Tab**
- **Matrix Tab**
- **AEC Reference/PA Adapt Reference Tab**
- **Gating Tab**
- **Control Tab**
- **Macro Tab**
- **String Tab**
- **Database Tab**
- **Drag & Drop Configuration**

FILE MENU OVERVIEW

File Menu allows you to use **Site Files** and **Print Reports**.

Accessing the File Menu

In Console, select **File** from the menu bar. The **File** menu appears as shown below:

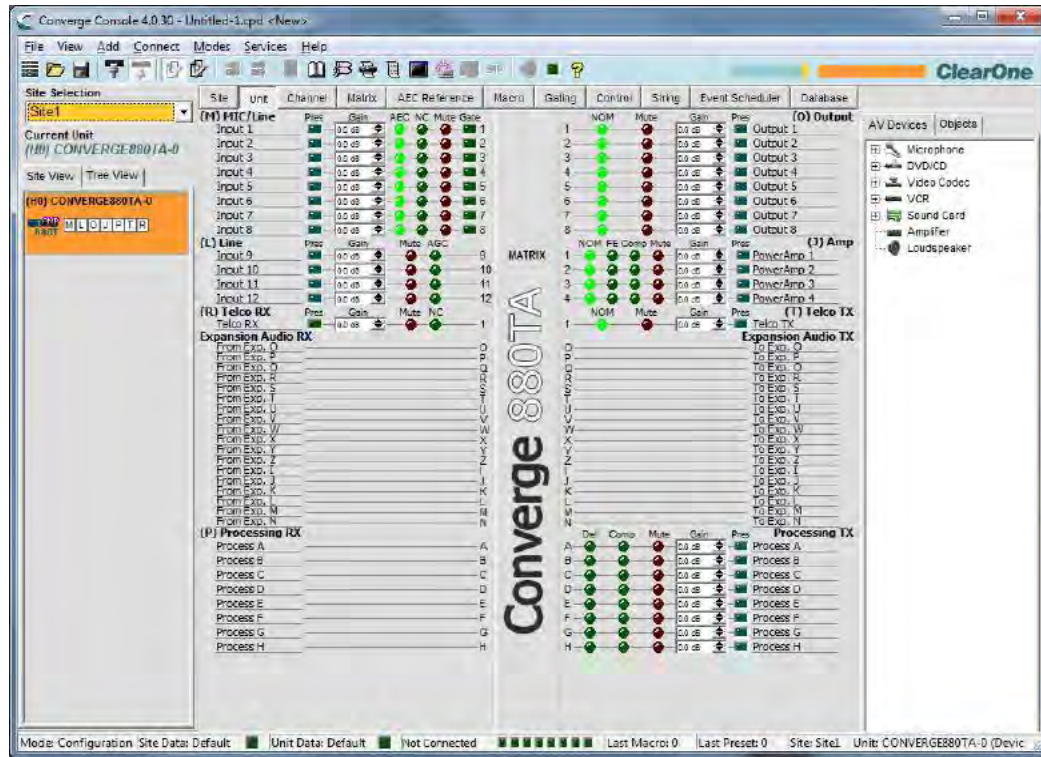

The **File** menu appears as shown below:

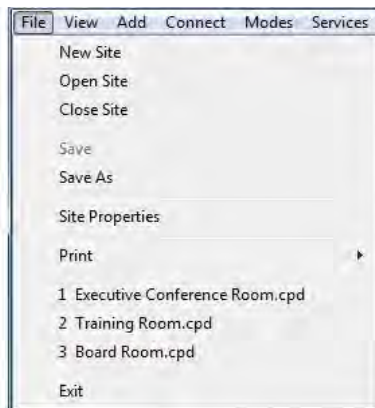

File menu options are explained in the following sections.

File Menu: Site Options

The File menu site options allow you to **Create a New Site**, open a saved site with **Open Site**, or close the current site with **Close Site**.

File Menu: Save Options

The File menu save options allow you to **Save** and **Save As** a site file.

File Menu: Print

Print allows you to create, view, print, and save Site and Unit configuration reports.

File Menu: Recent File List

The File menu recent file list displays the last four **Site Files** opened.

File Menu: Exit

The File menu **Exit** option closes Console. (To close the current Site without exiting Console, use the **Close Site** option.)

If you are **Connected to a Site**, a **Confirm** dialog appears when you select **Exit** as shown below.



Press **Yes** to confirm the exit or **No** to return to Console. Clicking **Yes** brings up another **Confirm** dialog as shown below.

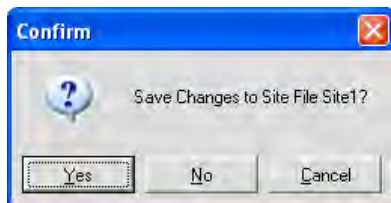

Click **Yes** to save changes to the Site File, **No** to exit Console without saving changes, or **Cancel** to abort the exit and return to Console.

For additional information, refer to the *Table of Contents* for these related topics:

- **Site File Overview**
- **Print Reports**
- **Create a New Site**
- **Connect To A Site**
- **Unit Properties**

PRINT REPORTS

The **Print Reports** option on the **File** menu allows you to print a configuration properties report for a Site or Unit.

Accessing Print Reports

To print a site or unit report, click on the **File** menu, select **Print**, then select **Print Site Report** or **Print Unit Report** as shown below.

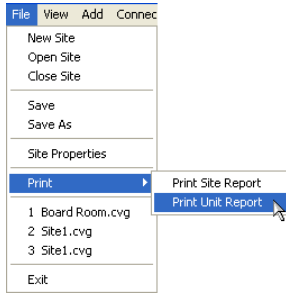

The **Report** window appears as shown below.

Report Window

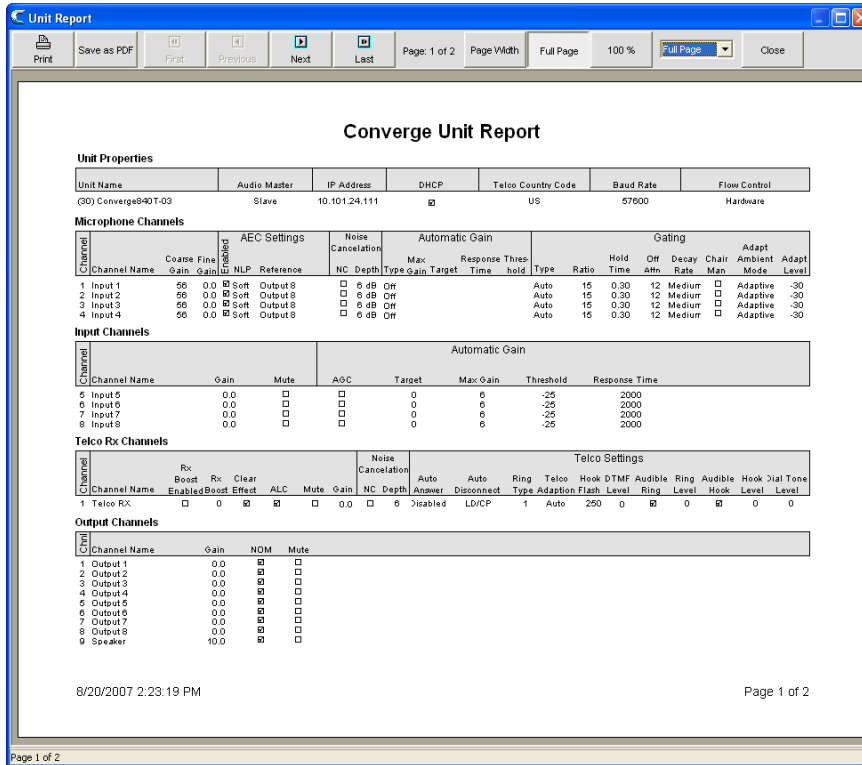

The report button bar provides buttons for viewing and printing the document, as well as saving the report to a PDF file. When you are finished viewing the report, click **Close** to close the report window and return to Console.

For additional information, refer to the *Table of Contents* for these related topics:

- **Site Properties**
- **Unit Properties**

VIEW MENU OVERVIEW

The **View Menu** provides an alternate navigation method for viewing the screens displayed by clicking on the **Console Tabs**.

Accessing the View Menu

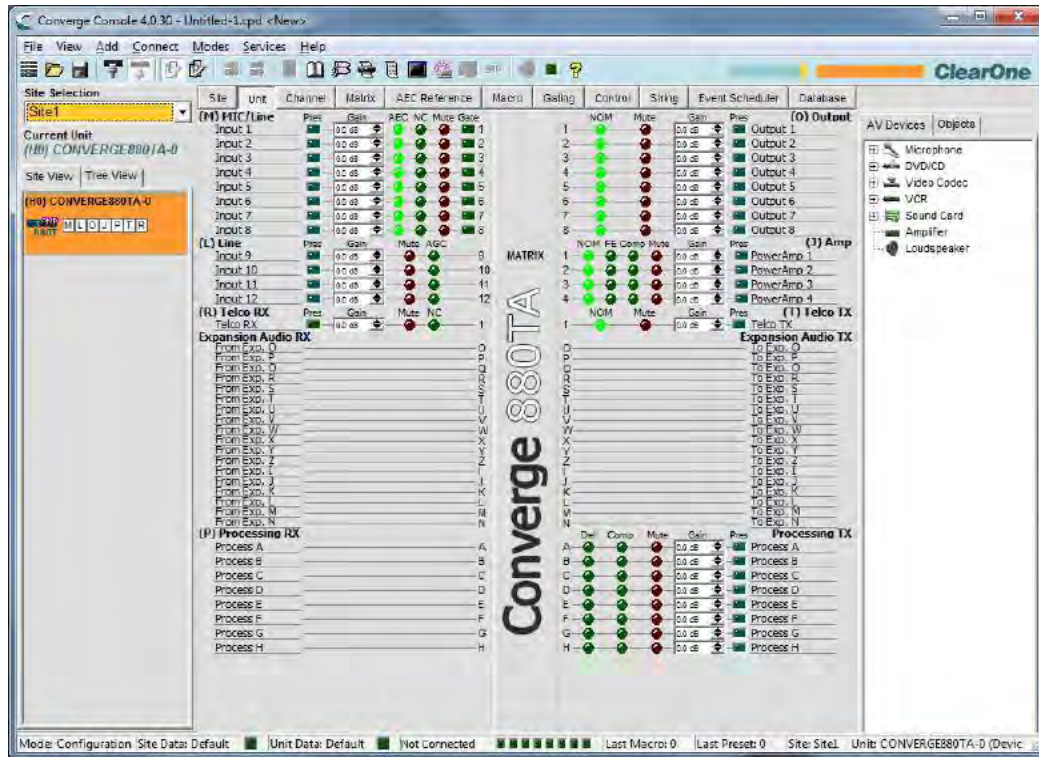

In Console, click **View** on the menu bar. The **View** menu appears as shown below:

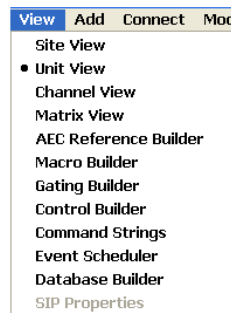

A bullet indicates the view currently displayed in Console.

View Menu Options

Options available on the View menu include:

- **Site View**
- **Unit View**
- **Channel View**
- **Matrix View**
- **AEC Reference Builder**
- **Macro Builder**
- **Gating Builder**
- **Control Builder**
- **Command Strings**
- **Event Scheduler**
- **Database Builder**

ADD MENU

The **Add Menu** allows you to add units to a site using default configuration settings.

Accessing the Add Menu

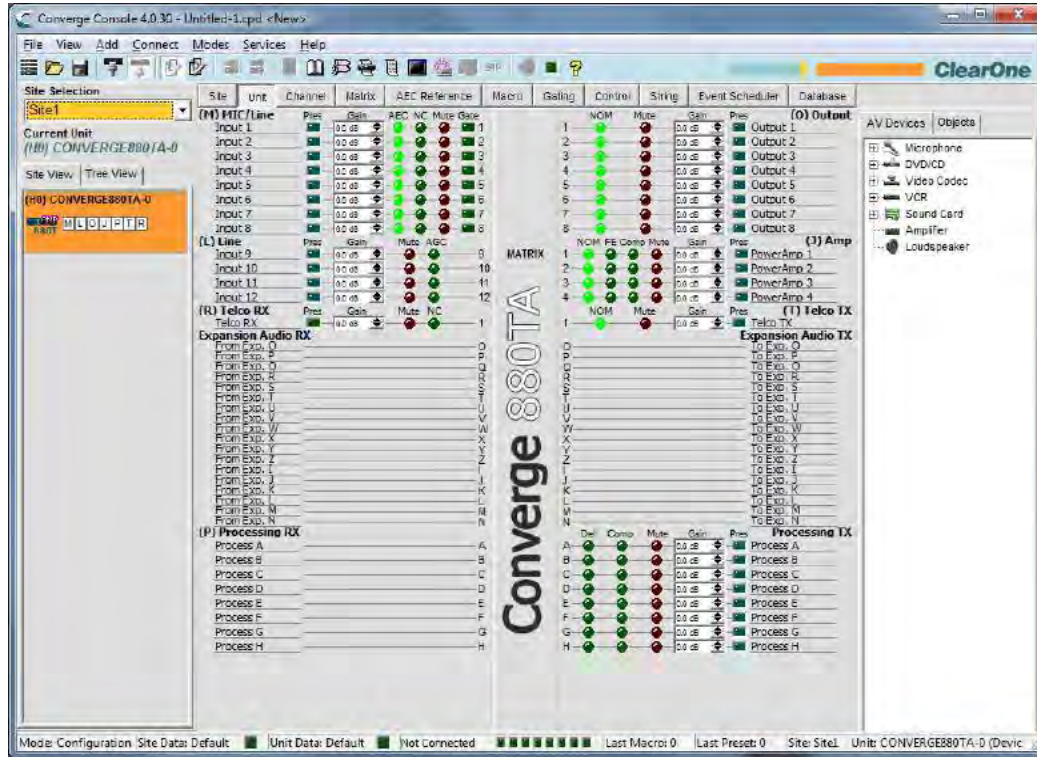

In Console, click **Add** on the menu bar. The **Add** menu appears as shown below:

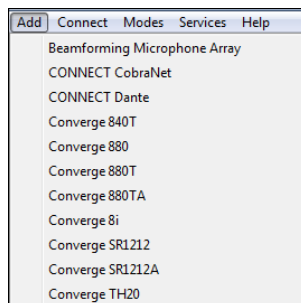

Adding Units

On the **Add** menu, select the model you want to add to the site. The **Unit Properties** dialog appears as shown below:

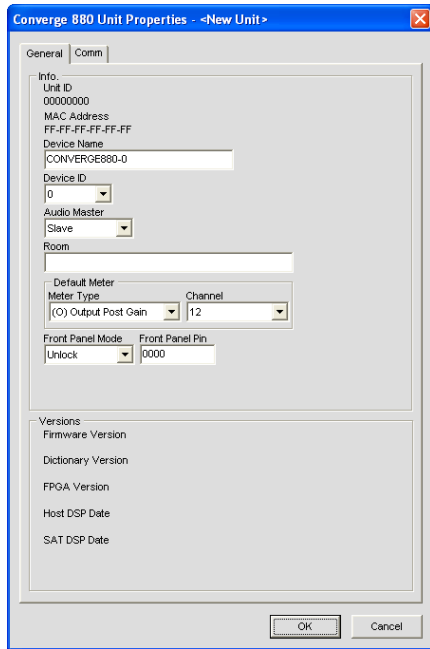

Configure the new unit's properties using the **General** tab. Configure the new unit's IP and serial port settings using the **Comm** tab. For more information on configuring unit properties, see **Unit Properties**.

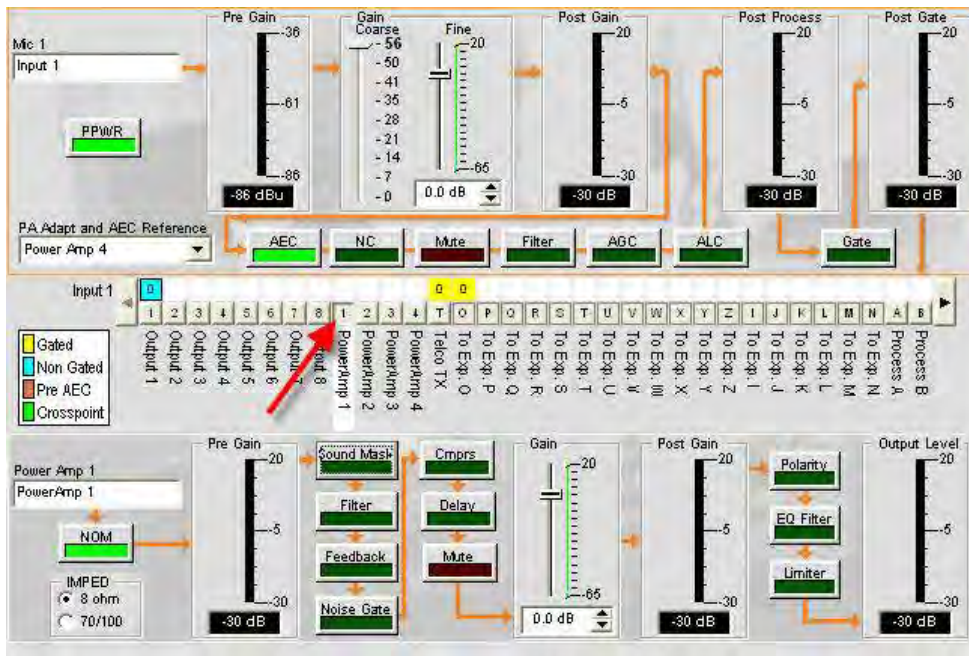

Press **OK** to add the unit to the site or **Cancel** to return to Console. The added unit appears on the **Site View** tab of the **Site pane**, highlighted in orange as shown below:

NOTE: The Status bar at the bottom of the Console window displays the current status of the unit and the site. As shown above, site data errors and unit data errors are indicated by magenta and red LEDs respectively. Complete unit configuration with correct settings to clear the errors. When correct configuration is complete, the status LEDs will change to green. The Status bar also displays Last Macro and Last Preset.

For more information, refer to the Table of Contents for these related topics:

- **Unit Properties**
- **Create A New Site**
- **Connect To A Site**
- **Site Properties**
- **Unit Tab**
- **Configuration Mode Overview**

CONNECT MENU OVERVIEW

The **Connect Menu** enables you to connect to a site, disconnect from a site, and refresh the current display for a site. Connecting to a site allows you to control and configure the units in that site. See **Site Setup Overview** for more information.

Accessing the Connect Menu

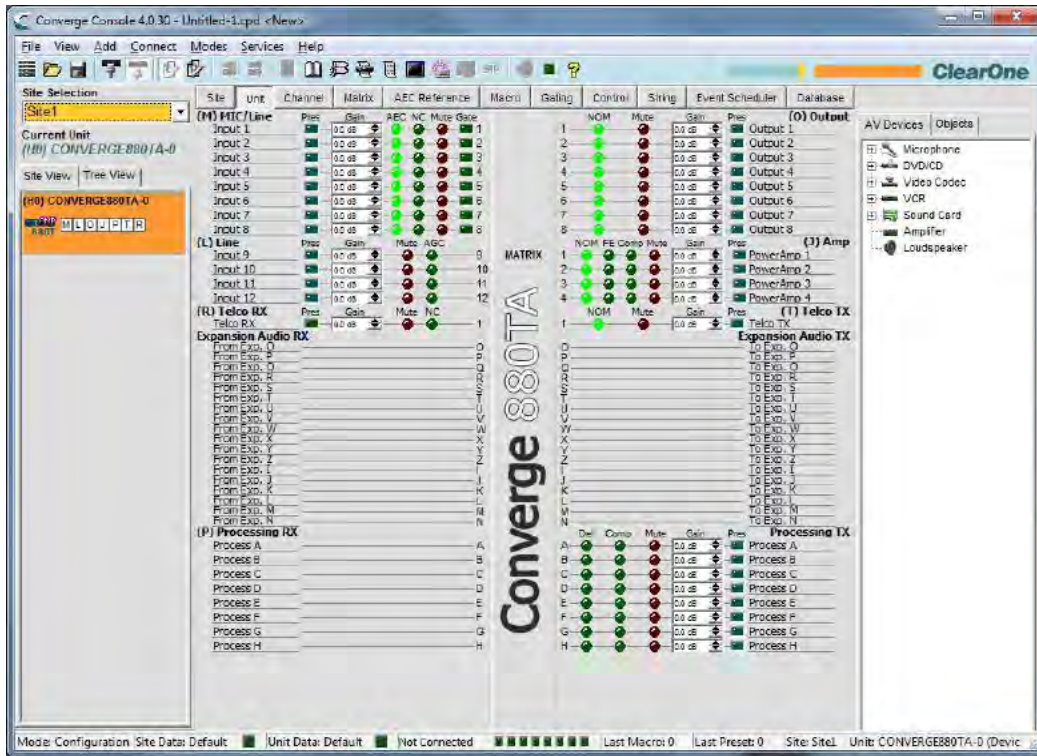

In Console, select **Connect** from the menu bar. The Connect menu appears as shown below:

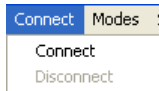

Connect Menu Options

- **Connect:** Connects to a site via USB or IP.
- **Disconnect:** Disconnects Console from the currently connected site. (This option is not available if no site is connected.)

For additional information, refer to the Table of Contents for these related topics:

- **Site Setup Overview**
- **Connect To A Site**
- **Create A New Site**

MODES MENU OVERVIEW

The **Modes Menu** allows you to switch Console between **Configuration Mode** and **Preset Mode**. Configuration Mode allows you to configure a wide range of advanced settings for all models. Preset Mode allows you to create presets for specific venues and apply them to instantly to a unit.

Accessing the Modes Menu

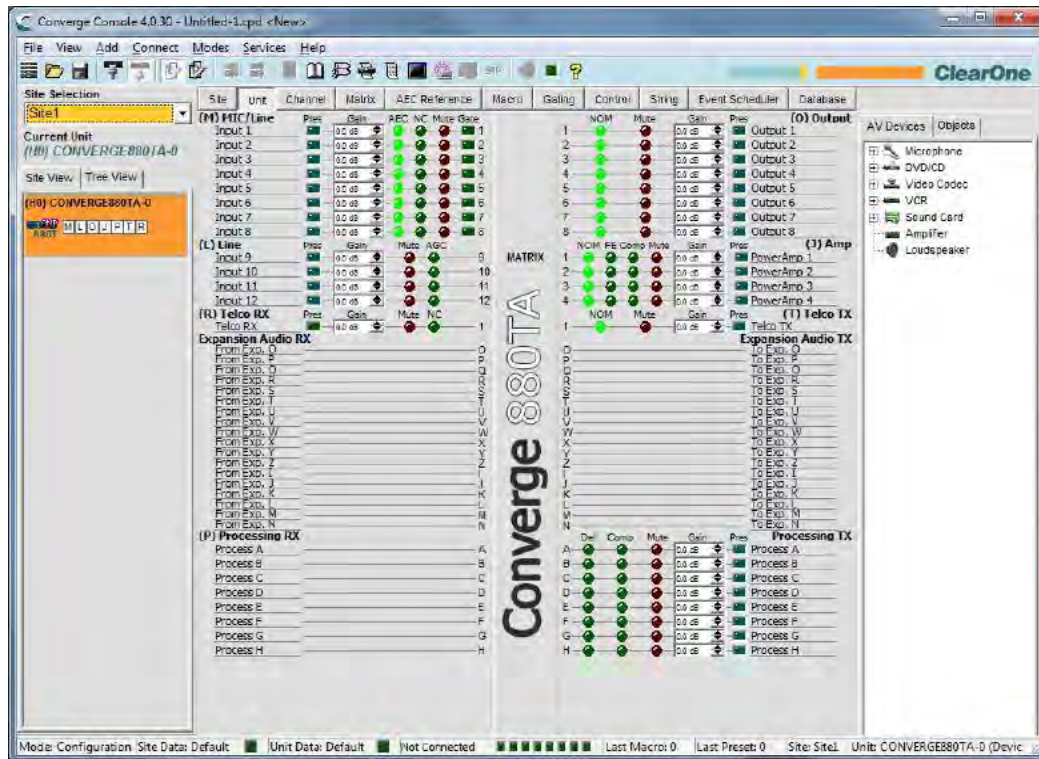

In Console, select **Modes** from the menu bar. The Modes menu appears as shown below:

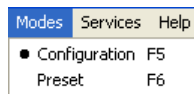

A bullet indicates the current mode. To switch modes, select **Configuration** or **Preset**. Console immediately reflects mode changes.

NOTE: You can also switch modes using the  buttons on the Console Button Bar.

For additional information, refer to the Table of Contents for these related topics:

- **Configuration Mode**
- **Preset Mode**
- **Console Button Bar**

SERVICES MENU OVERVIEW

The **Services Menu** provides various utilities for using and managing CONVERGE/CONVERGE Pro units.

Accessing the Services Menu

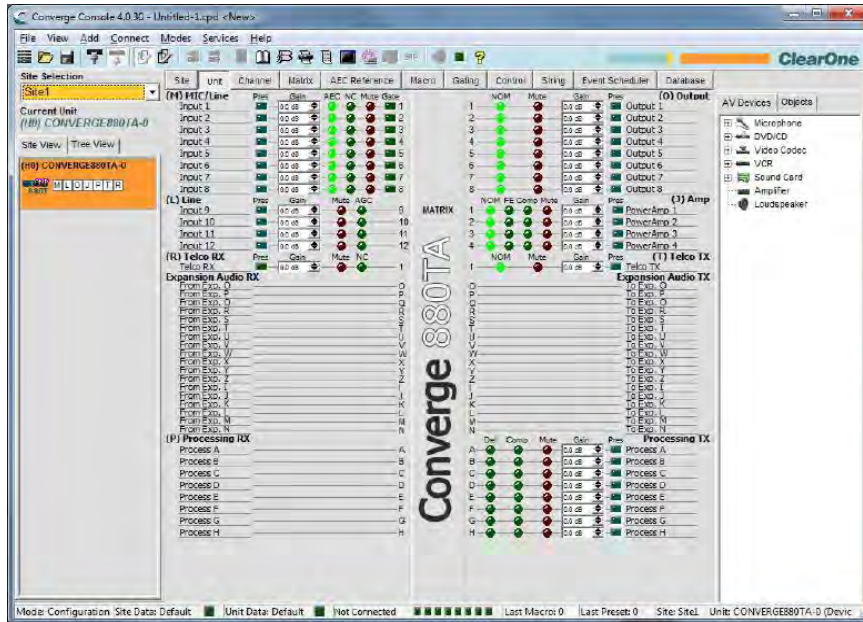

In Console, click **Services** on the menu bar. The Services menu appears as shown below:

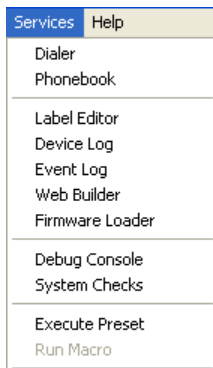

Service Menu Options

Options available on the Services menu include:

- **Dialer**
- **Phonebook**
- **Label Editor**
- **Device Log**
- **Event Log**
- **Firmware Loader**
- **Debug Console**
- **System Checks**
- **Execute Presets**
- **Web Builder**

DIALER

The **Dialer** provides a software telephone interface for teleconferencing applications.

NOTE: Dialer is only available when Console is connected to a site.

Accessing Dialer

To access the dialer, select **Dialer** from the Services menu; press the **Dialer**  button on the Console **Button Bar**; or press the **Dialer** button in the **Telco Rx** or **Telco Tx** channel screens.

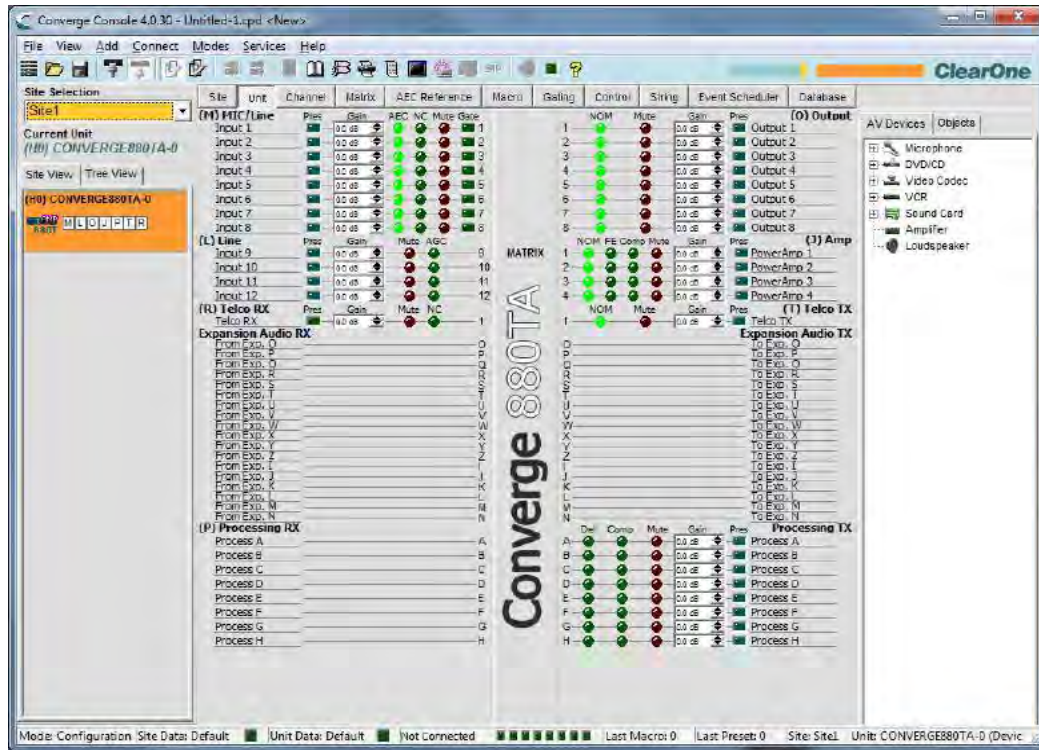

Using Dialer

When using the dialer, the date and time, number dialed, and call status are displayed in the LCD section of the dialer window.



Placing and Ending Calls

To place a call, select a number from the **Phonebook** section of the dialer window, or manually enter a number, then press the **ON/OFF** hook button.

You can also access the Phonebook by pressing the **PHONEBOOK** button.

To end a call, press the **ON/OFF** hook button.

To redial a number, press the **REDIAL** button.

Using Line Features

Use the **FLASH** button to access Telco and PBX line features.

Muting

Use the **MUTE Tx** and **MUTE Rx** buttons to mute the transmit and receive signals respectively when a call is in progress.

Renulling the Line

During conference calls, line conditions and other factors can cause divergence in the automatic **Telephone Echo Cancellation (TEC)** adaptation process. If side tone occurs during a conference call, press the **RE_NULL** button to send a short burst of white noise over the line and initiate TEC readaptation (**Not supported in VoIP functionality**).

NOTE: Renulling the line sends a burst of white noise that will be audible on the far end of the telephone line.

For more information, please see the *Table of Contents* for these related topics:

- **Connect To A Site**
- **Services Menu Overview**
- **Telco/VoIP Rx Settings**
- **Telco/VoIP Tx Settings**
- **Phonebook**
- **Telephone Echo Cancellation**

PHONEBOOK

The **Phonebook** allows you to store telephone numbers and make speed-dial assignments for teleconferencing applications.

Accessing Phonebook

To access the phone book, select **Phonebook** from the Services menu; press the **Phonebook**  button on the Console **Button Bar**; or press the **Phonebook** button in the **Dialer** screen.



Using Phonebook

To add an entry to the phonebook, press the **New Entry** button; enter a **Name** and **Number**; and select a **Speed Dial Number** (optional).



NOTE: The Number field allows numbers, #, and * only. No other characters (such as parentheses and dashes) are allowed.

Press the **Add** button to add the entry to the phonebook. The number now appears in the phonebook list, and in the **Phonebook** portion of the **Dialer** screen.

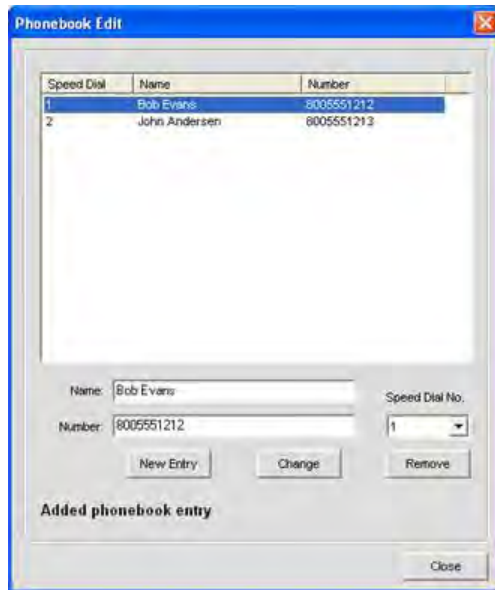

To edit an entry, select it and press the **Change** button. To delete an entry, select it and press the **Remove** button.

For additional information, please refer to the Table of Contents for these related topics:

- **Dialer**
- **Button Bar**
- **Services Menu Overview**

LABEL EDITOR

The Label Editor allows you to quickly change the names (labels) assigned to units and channels. Using descriptive names makes it easier to identify units and channels for configuration and management purposes. Label changes are global, and appear throughout Console wherever the label is referenced.

In addition to using the label editor to rename objects, you can use the label entry fields provided throughout Console.

Accessing Label Editor

To access the label editor, select **Label Editor** from the **Services** menu, or click the **Label Editor**  button on the CONVERGE **Button Bar**.

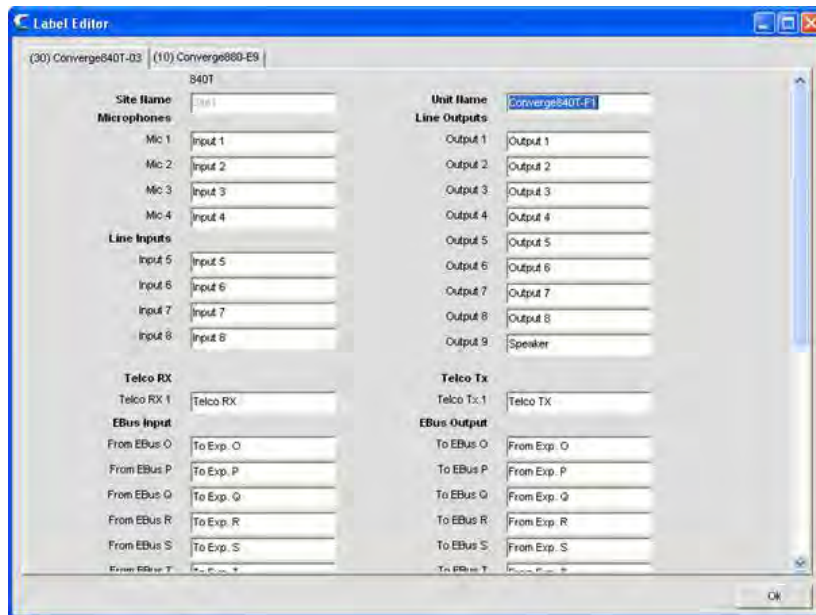

Using Label Editor

As shown above, the label editor contains one tab for each unit in the currently connected site. To modify a label, select the unit tab and click on the entry field for the object name that you wish to change. When finished, click the **Ok** button to save the changes and close the label editor window.

For additional information, please refer to the *Table of Contents* for these related topics:

- **Services Menu Overview**
- **Mic Input Settings**
- **Line Input Settings**
- **Telco/VoIP Rx Settings**
- **Output Settings**
- **Telco/VoIP Tx Settings**
- **Processing Settings**
- **Fader Settings**

DEVICE LOG

The **Device Log** captures device events for administration, configuration, and troubleshooting purposes.

NOTE: The device log can store 256K bytes of data. Once this limit is reached, the first 128K of data is truncated and logging resumes.

Accessing Device Log

To access the device log, select **Device Log** from the **Services** menu, or click the **Device Log**  button on the Console **Button Bar**.

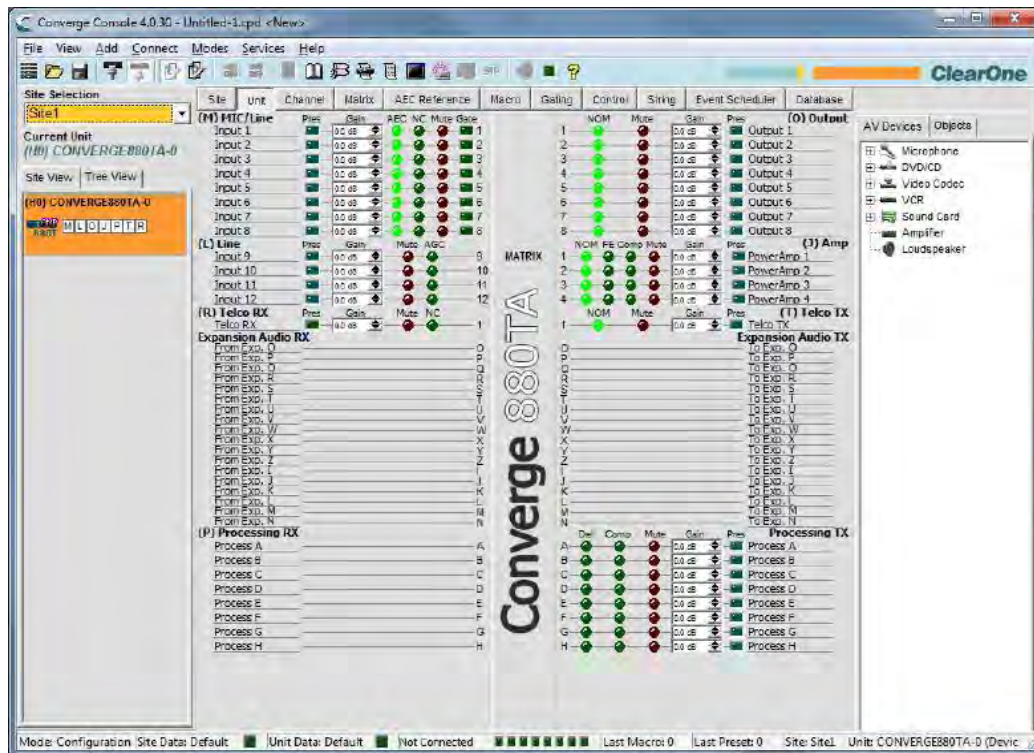

Using Device Log

In the **Device Log** window, select the events you want to log using the **Event Selection** check boxes.

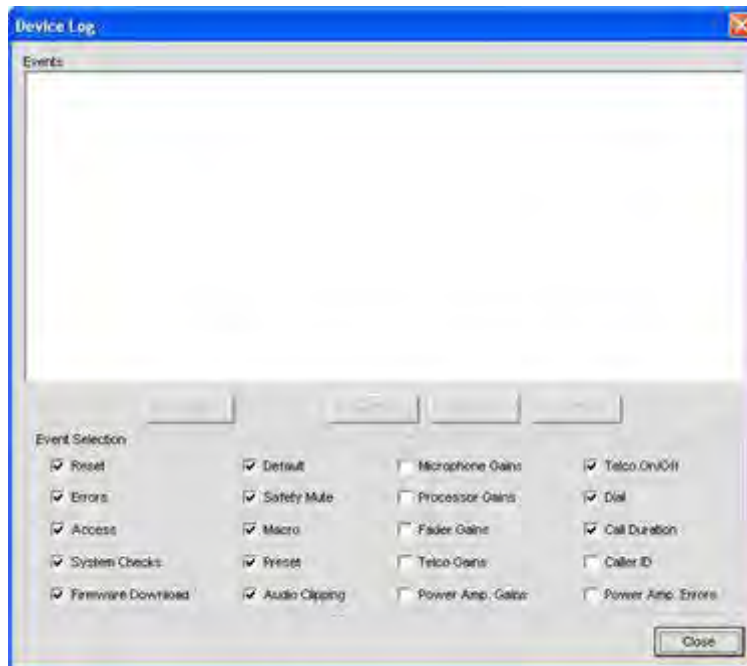

Events available for logging include:

- **Reset:** Reports unit reset events
- **Errors:** Reports internal unit errors
- **Access:** Reports all web, Telnet, front panel, and USB access events
- **System Checks:** Reports the pass/fail status of System Checks
- **Firmware Download:** Reports firmware downloads
- **Default:** Reports unit default events
- **Safety Mute:** Reports safety mute events
- **Macro:** Reports Macro execution events
- **Preset:** Reports when Presets are run
- **Audio Clipping:** Reports audio clipping events
- **Telco On/Off:** Reports when the Telco line goes on or off hook
- **Dial:** Reports dial command events including DTMF, Phonebook, Speed Dial, and Redial
- **Call Duration:** Reports the time between on and off hook events for all calls
- **Microphone Gains:** Reports microphone gain levels
- **Processor Gains:** Reports processor gain levels
- **Fader Gains:** Reports fader gain levels
- **Telco Gains:** Reports Telco gain levels
- **Power Amp. Gains:** Reports power amp gain levels
- **Caller ID:** Shows Caller ID report
- **Power Amp. Errors:** Reports power amp errors

NOTE: All device events and Event Scheduler events are logged automatically.

Use the **Refresh**, **Clear**, **Save**, and **Print** buttons to refresh the log display, clear the log, save the log to a text file, and print the log.

For additional information, please refer to the *Table of Contents* for these related topics:

- **Site Properties**
- **System Checks**
- **Firmware Loader**
- **Console Overview**
- **LCD Settings Menu**
- **Macro Tab**
- **Preset Mode Overview**
- **Execute Presets**
- **Dialer**
- **Phonebook**

EVENT LOG

The **Event Log** captures Console events for administration and troubleshooting purposes. Event types captured include failed login attempts, site disconnects, unit reboots, socket time outs, internal system errors, and serial command execution errors.

Accessing Event Log

To access the event log, select **Event Log** from the **Services** menu, or click the **Event Log** button on the Console **Button Bar**.

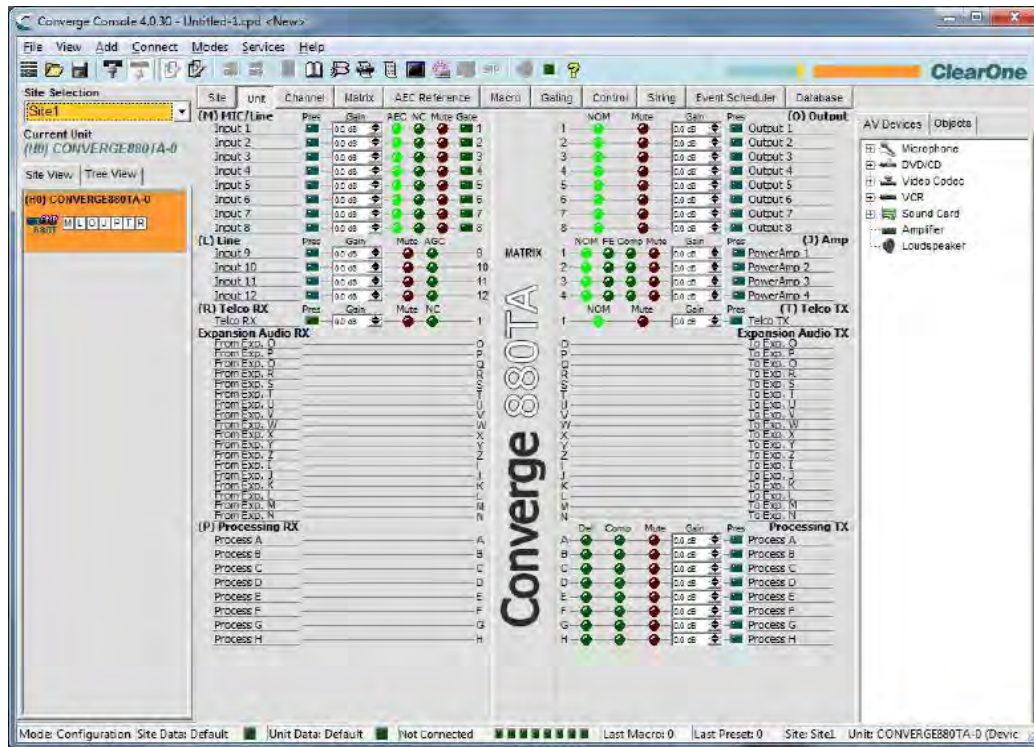

Using Event Log

Captured events appear in the left section of the Event Log window. **Event Codes** and **Messages** appear in the right section of the window.

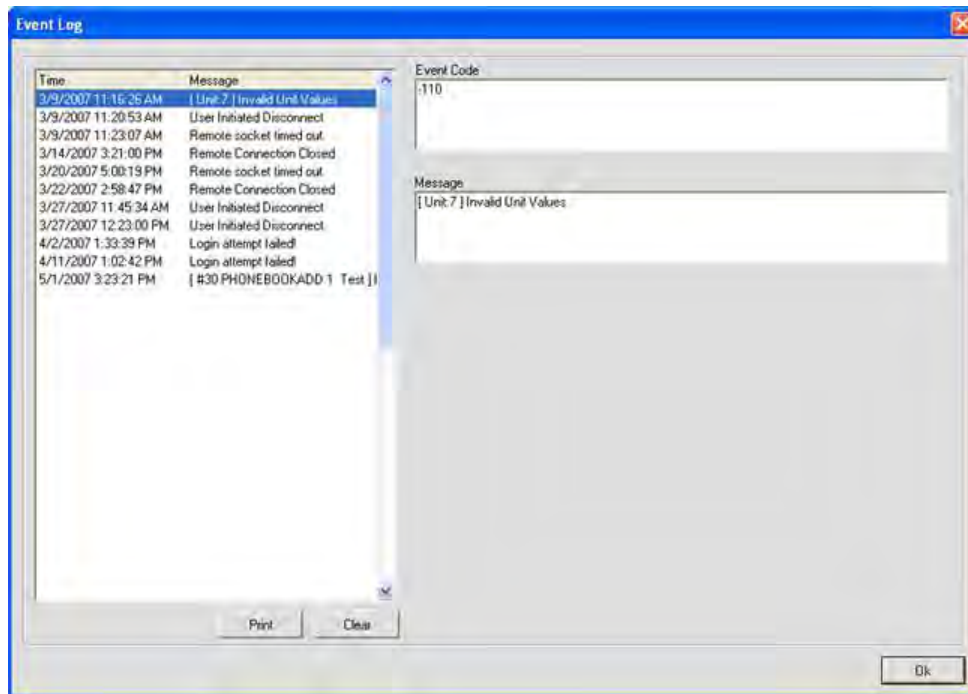

To print the event log, press the **Print** button. To clear the event log, press the **Clear** button and answer **Yes** to the confirmation dialog that appears.

For additional information, please refer to the Table of Contents for these related topics:

- **Services Menu**
- **Event Scheduler**

WEB BUILDER

Web Builder consists of User Console and Control Console. These consoles allow you to configure a subset of call management and mixing features for access through a web portal integrated into the firmware. The web portal can be accessed over IP with Microsoft's Internet Explorer (requires IE version 5.5 or later and Sun Microsystems Java Runtime Environment version 6.0 or higher).

User Console allows you to configure basic call functions, including on/off hook, redial, volume, and mute, for up to two units. Control Console allows you to perform basic channel and mixing configuration tasks for all units.

Accessing Web Builder

To access the web builder, select **Web Builder** from the **Services** menu, or press the **Web Builder**  button on the Console **Button Bar**.

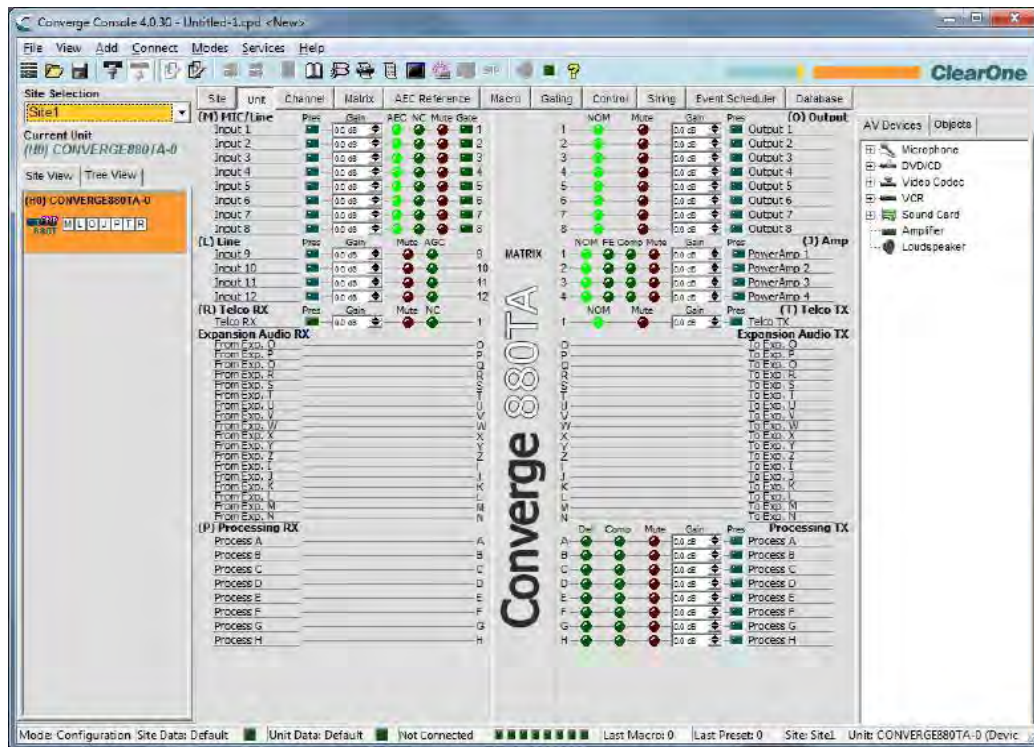

Configuring User Console

The User Console tab allows you to configure the web version of Dialer, a software interface that emulates the functionality of ClearOne's Tabletop Controller. User Console provides six user-programmable keys as described in the following sections.

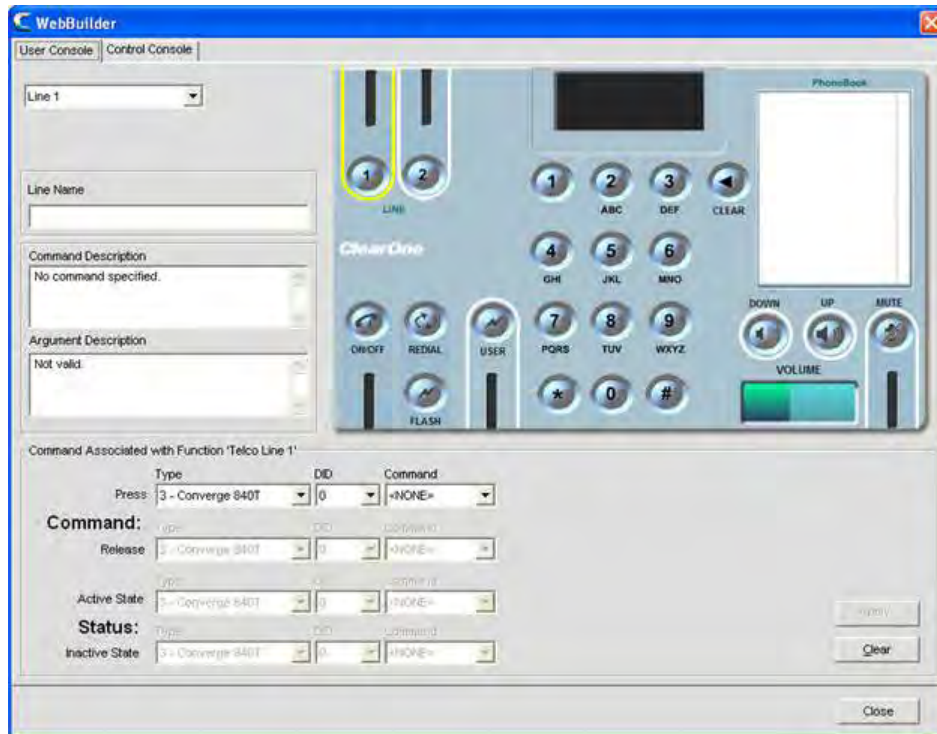

Select the key you want to program from the drop-down list in the upper left hand corner of the screen. Programmable keys include:

- **Line 1**
- **Line 2**
- **User**
- **Volume Down**
- **Volume Up**
- **Mute**

If you are configuring a **Line** or **User** button, enter a name for it in the **Line** (or **User**) **Name** field (optional).

The key selected determines the commands available in the **Command** drop-down lists in the **Command** section of the screen.



For example, the commands available for the volume buttons include **GAIN**, **MACRO**, and **RAMP**. When you select a command, the configurable parameters for that command appear as shown above. (For more information on the command editor, see **Command Editor** in the **Control Tab** topic.)

Select the **Type**, **DID** (device ID), and **Command** from the drop-down lists. After selecting a command and configuring its parameters, press the **Apply** button to save the button programming. To clear a command, press the **Clear** button.

For some commands, such as **MACRO**, the **Status** section of the command editor becomes active. **Status** controls the LED status indicator for the associated button based on the state conditions entered in the **Active State** (LED on) and **Inactive State** (LED off) rows of the **Status** section.

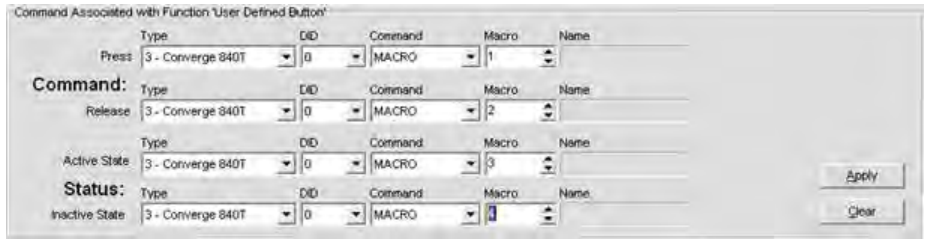

Pressing a programmed button in the Web Portal executes the command selected in the Press row of the Command section. Releasing a button executes the command selected in the Release row (if applicable for the programmed command).

Configuring Control Console

Control Console provides eight fader groups (mixers) with gain sliders, mute buttons, and level meters. It also provides four user-programmable buttons. The fader groups can control multiple units in a site.

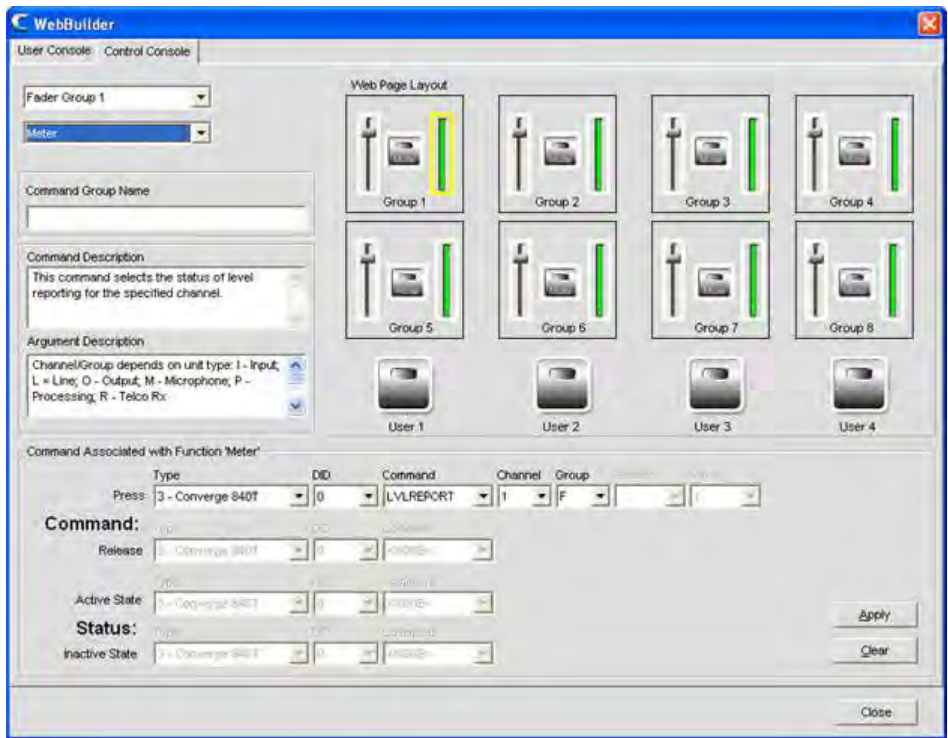

Select the fader group or user key you want to program from the drop-down list in the upper left hand corner of the screen. For fader groups, you will also need to select **Gain**, **Mute**, or **Meter** from the second drop-down list.

NOTE: You can also select an element to program, such as a gain slider or user button, by selecting its graphical representation in the Control Console window. For example, in the screen shot above, the meter element for Fader Group 1 is selected. The LVLREPORT command associated with the meter will display real-time level of fader group on the CONVERGE Pro 840T unit (DID 0).

The element selected determines the commands available in the **Command** drop-down lists in the **Command** section of the screen.

Command Associated with Function 'Mute'

	Type	DID	Command	Macro	Name	
Press	3 - Converge 840T	0	MACRO	1	Gain 12dB	
Command:	Type	DID	Command			
Release	3 - Converge 840T	0	<NONE>			
	Type	DID	Command	Channel	Group	Mode
Active State	3 - Converge 840T	0	MUTE	1	F	1
Status:	Type	DID	Command	Channel	Group	Mode
Inactive State	3 - Converge 840T	0	MUTE	1	F	0

Buttons: Apply, Clear

For example, the commands available for the mute buttons include **MACRO** and **MUTE**. When you select a command, the configurable parameters for that command appear as shown above. (For more information on the command editor, see **Command Editor** in the *Control Tab* topic.)

Select the **Type**, **DID** (device ID), and **Command** from the drop-down lists. After selecting a command and configuring its parameters, press the **Apply** button to save the button programming. To clear a command, press the **Clear** button.

For some commands, such as **MACRO**, the **Status** section of the command editor becomes active. Status controls the LED status indicator for the associated button based on the state conditions entered in the **Active State** (LED on) and **Inactive State** (LED off) rows of the **Status** section.

Command Associated with Function 'User Defined Button'

	Type	DID	Command	Macro	Name
Press	3 - Converge 840T	0	MACRO	1	
Command:	Type <td>DID <td>Command <td>Macro <td>Name</td> </td></td></td>	DID <td>Command <td>Macro <td>Name</td> </td></td>	Command <td>Macro <td>Name</td> </td>	Macro <td>Name</td>	Name
Release	3 - Converge 840T	0	MACRO	2	
	Type <td>DID <td>Command <td>Macro <td>Name</td> </td></td></td>	DID <td>Command <td>Macro <td>Name</td> </td></td>	Command <td>Macro <td>Name</td> </td>	Macro <td>Name</td>	Name
Active State	3 - Converge 840T	0	MACRO	3	
Status:	Type <td>DID <td>Command <td>Macro <td>Name</td> </td></td></td>	DID <td>Command <td>Macro <td>Name</td> </td></td>	Command <td>Macro <td>Name</td> </td>	Macro <td>Name</td>	Name
Inactive State	3 - Converge 840T	0	MACRO	4	

Buttons: Apply, Clear

Changing the settings of a fader group element, or pressing a programmed button in the Web Portal executes the command selected in the Press row of the Command section. Releasing a button executes the command selected in the Release row (if applicable).

Accessing the Web Portal

After programming User Console and Control Console, you can access them using the Web Portal to monitor and manage audio conferences.

User access privileges to these web-based management tools are as follows:

- **Administrator:** Full web access.
- **Manager:** Web access to Dialer, Maintenance, Registration, About, and Help pages.
- **User:** Web access to the Dialer, Registration, About, and Help pages.

To open the web portal, enter the IP address of the unit you want to connect with. The web portal appears as shown below.



To access programmed call management functions, click on **DIALER**. To access programmed control console mixing functions, click on **MANAGEMENT** (shown above).

For additional information, please refer to the Table of Contents for these related topics:

- **Dialer**
- **Phonebook**
- **Macro Tab**
- **Mic Gating**
- **Mic Input Settings**
- **Line Input Settings**
- **Telco/VoIP Rx Settings**
- **Telco/VoIP Tx Settings**
- **Output Settings**
- **Matrix Tab**

FIRMWARE LOADER

Firmware Loader allows you to upgrade firmware when ClearOne releases enhancements. All models use the same firmware file (converge.mdo). When upgrading firmware, all units in the site are automatically updated simultaneously.

NOTE: Before upgrading firmware, save a copy of your site files using the Save or Save As options on the File menu. When upgrading from CONVERGE Console 1.0.4 or 1.1.5 to 2.0.x or 3.0.x the Firmware must be updated twice.

Accessing Firmware Loader

To load firmware, click on the **Services** menu select **Firmware Loader**. The **CONVERGE Firmware Loader** window appears as shown below.

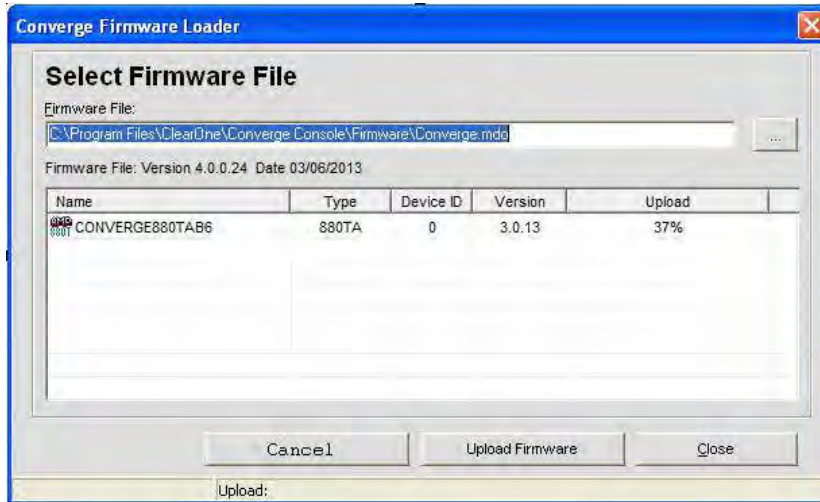

Loading Firmware

Firmware Loader automatically looks for firmware files in the default CONVERGE Console directory.

Press the  button to locate firmware files stored in a different directory, or enter an explicit file path into the **Firmware File** entry field. All available firmware files in the chosen directory are displayed in the firmware file table.

Once you have located the firmware file you want to load, select it from the firmware file table and click **Upload Firmware**. A warning dialog appears (shown below). Click **Yes** to proceed with the firmware upload.

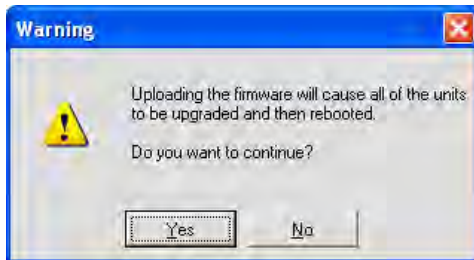

The upload begins, and the Firmware Loader displays progress in the **Upload** column of the firmware file table, and in the Status Bar at the bottom of the window as shown below:

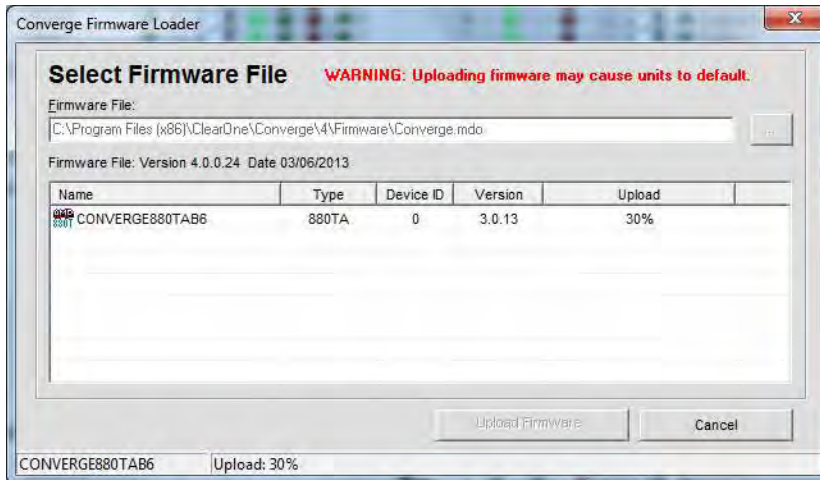

In addition, the LED indicators on the status bar in Console turn purple to indicate the firmware load is in progress as shown below:

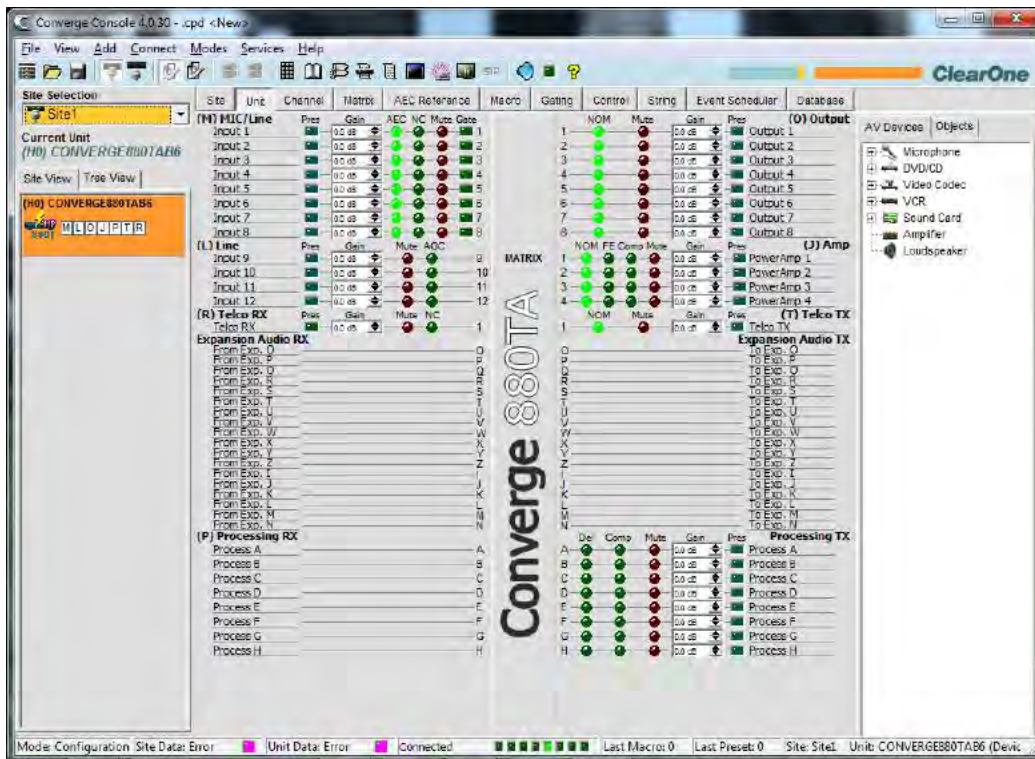

When the firmware load is complete, the unit reboots. The unit now has the selected firmware file loaded.

If you experience problems with firmware loads, please contact ClearOne Technical Support.

CONVERGE Firmware Update Procedure

The 4.X versions of CONVERGE Console offer significant upgrades from previous versions, including support for the Beamforming Microphone Array. ClearOne strongly encourages users to upgrade all firmware to the latest release version.

NOTE: Save the CONVERGE Console site file before performing any firmware upgrade

NOTE: CONVERGE Console checks for firmware/software compatibility when connecting to a CONVERGE Pro site. If a compatibility issue is found the firmware uploader screen will be presented to update the firmware. Follow the steps below to update the firmware. If you choose not to perform the firmware update, close CONVERGE Console and use CONVERGE Manager to select the version of CONVERGE Console that is compatible with the firmware in the CONVERGE Pro.

If the connected Site contains units that are Version 3.X, they must be removed from the expansion bus prior to performing the firmware upgrade.

Please follow the steps below to upgrade your Firmware:

Upgrading from 1.X Firmware

1. Remove any 2.X, 3.X and 4.X units from the stack by disconnecting the expansion bus link cable from the 1.X units.
2. Re-connect to the 1.X stack with Console.
3. Download the 4.X firmware file to the stack of units.
4. The units will default and reboot after the download of 4.X firmware. The 1.X to 4.X upgrade requires the firmware to be loaded twice to complete the version upgrade.
5. Reconnect to the stack with Console. Download 4.X a second time to the units. The units will reboot.
6. Units are fully upgraded.
7. Verify units have been upgraded by check firmware version on the front panel.

Upgrading from 2.X Firmware

1. Remove any 1.X, 3.X and 4.X units from the stack by disconnecting the expansion bus link cable from the 2.X units.
2. Re-connect to the 2.X stack with Console.
3. Download the 4.X firmware file to the stack of units.
4. The units will default and reboot after the download of 4.X firmware. The 2.X to 4.X upgrade requires the firmware to be loaded twice to complete the version upgrade.
5. Units are fully upgraded.
6. Verify units have been upgraded by check firmware version on the front panel.

Upgrading from 3.X Firmware

1. Remove any 1.X, 2.X and 4.X units from the stack by disconnecting the expansion bus link cable from the 3.X units.
2. Re-connect to the 3.X stack with Console.
3. Download the 4.X firmware file to the stack of units.
4. The units will default and reboot after the download of 4.X firmware.
5. Units are fully upgraded.
6. Verify units have been upgraded by check firmware version on the front panel.

The units have been upgraded. Reconnect all expansion bus cables, if needed, to complete the stack of units.

Upgrading the Beamforming Microphone Array Firmware

NOTE: All CONVERGE Pro units in the site must be running firmware 4.X to be compatible with the Beamforming Microphone Array. Follow the appropriate procedure above to update the firmware on the CONVERGE Pro units.

1. Connect the expansion bus cable between the CONVERGE Pro unit and the Beamforming Microphone Array.
2. Connect the CONVERGE Pro units with CONVERGE Console.
3. Open the firmware uploader screen.
4. Browse for the bf_mic.mdo file.
5. Download the Beamforming Microphone Array firmware.
6. The Beamforming Microphone Array(s) will default and reboot after the download of 4.X firmware.
7. Units are fully upgraded.

For additional information, please refer to the *Table of Contents* for these related topics:

- **Configure Unit Properties**
- **Configuration Mode Overview**
- **Customer Service and Support**

DEBUG CONSOLE

The Debug Console provides five tabs for monitoring system performance, testing and troubleshooting audio performance, and running system diagnostics:

- Meter View
- Gate View
- Signal Generator
- System Checks
- System Check Config

Accessing Debug Console

To access the debug console, select **Debug Console** from the **Services** menu, or press the **Debug Console** button on the Console **Button Bar**.

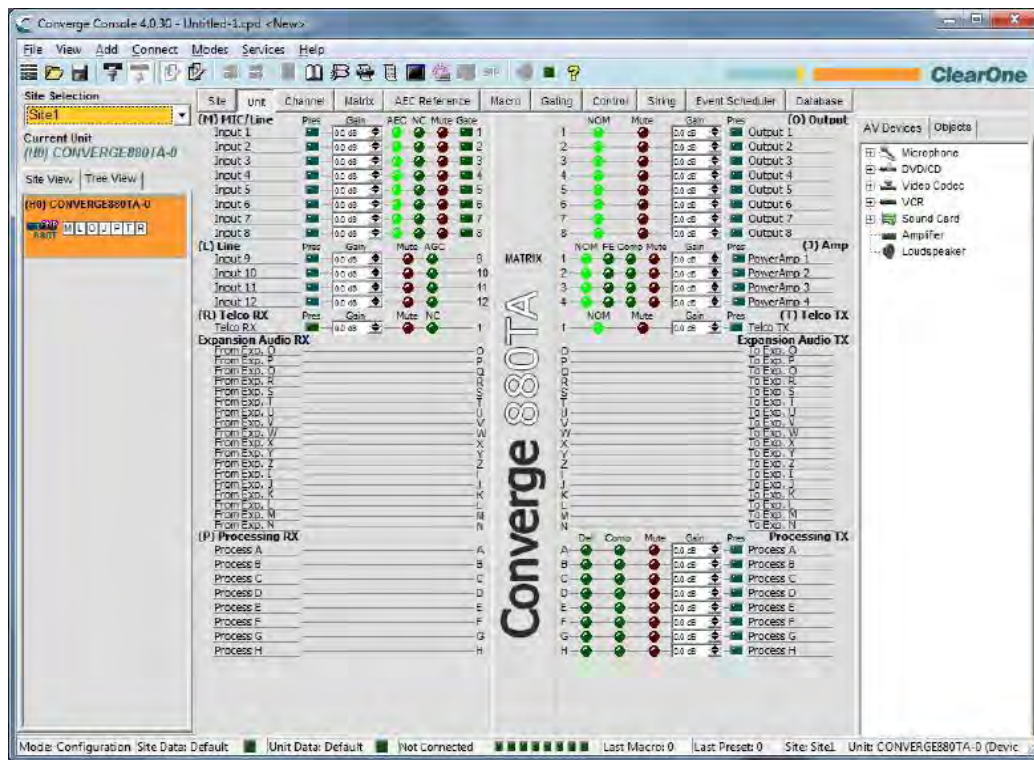

Debug console tabs are described in the following sections.

Meter View Tab

The **Meter View** tab provides eight user-configurable level meters for monitoring signal levels on any channel in a site.

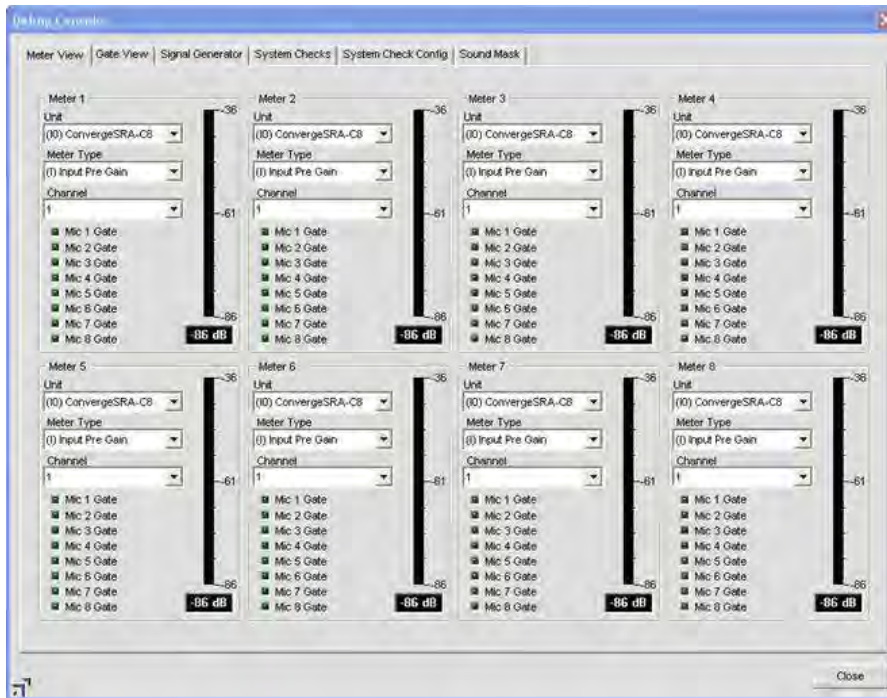

To configure a meter, select the **Unit**, **Meter Type**, and **Channel** using the drop-down lists. Meter view provides a useful diagnostic tool for system-wide troubleshooting and configuration.

Gate View Tab

The **Gate View** tab shows real-time gating status, allowing you to monitor gating activity for the mics and gating groups for the currently connected unit.

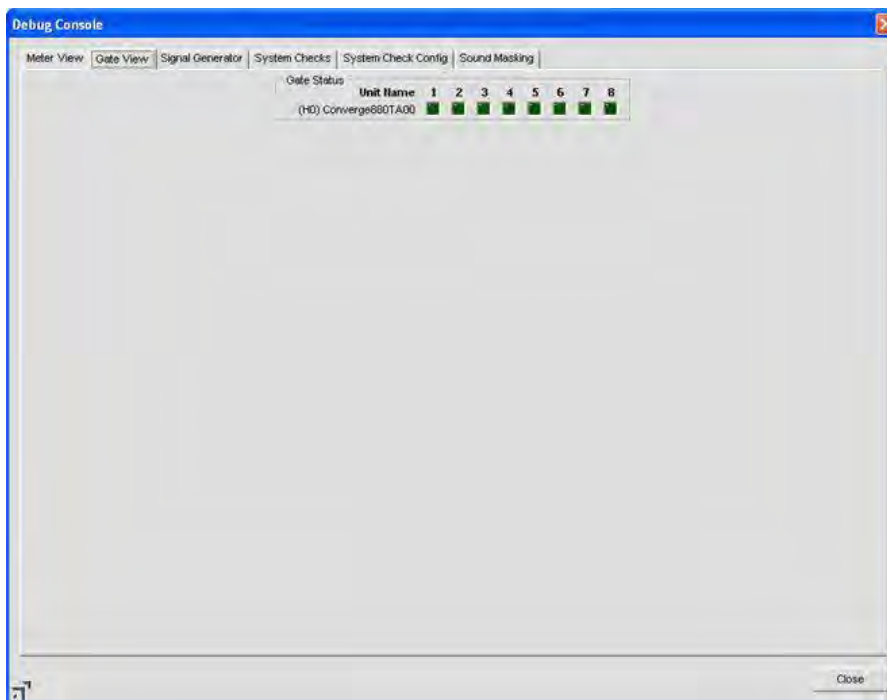

The gate indicator for each input is dark green in the gate-off condition and light green if the input is gated on.

Signal Generator

The **Signal Generator** tab enables you to generate test signals to audibly test signal paths, gain settings, routing, and channel configuration settings. The signal generator can also be used for noise masking in courtroom, clergy, and corporate applications.

NOTE: When the signal generator is on for any unit in the site, the **Signal Generator LED** on the Console Button Bar flashes green.

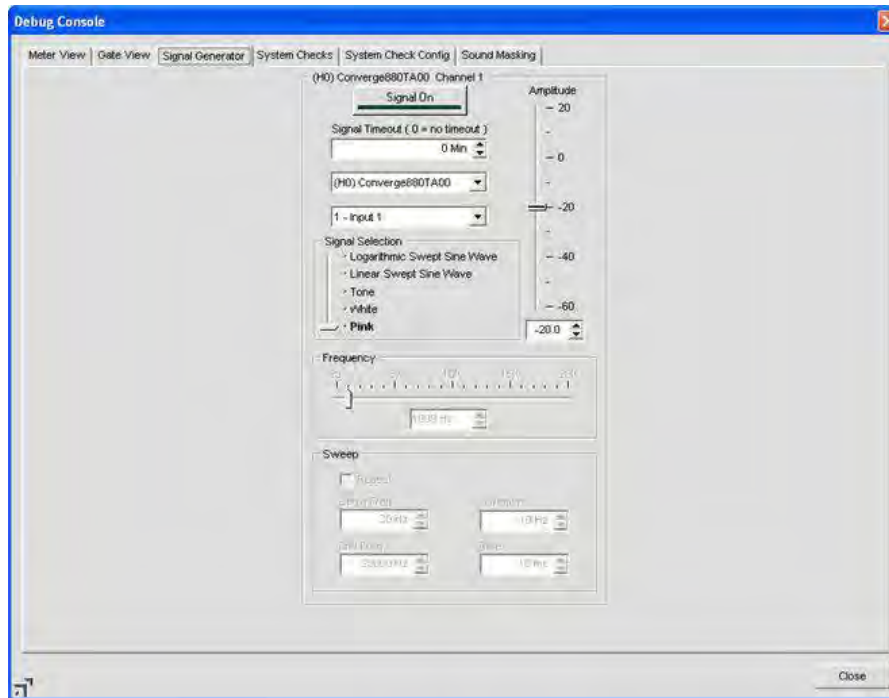

Test Signal Types

The signal generator provides three types of test signals: **Pink**, **White**, and **Tone**.

- **Pink Noise:** A test signal containing all the frequencies in a given audio spectrum, with equal energy in each octave. Pink noise is the default signal.
- **White Noise:** A test signal with equal energy distribution throughout a given frequency range.
- **Tone:** A sine-wave test signal with less than .03% distortion. Selecting **Tone** with the **Signal Selection** slider activates the **Frequency** configuration section of the tab.
- **Linear Sweep Sine Wave:** A test signal increasing in frequency using predefined steps.
- **Log Sweep Sine Wave:** A test signal increasing in frequency using exponential steps (rises on a curve).

Running a Signal Test

Use the following procedure to run a signal test:

1. Select the unit and channel to test using the unit and channel drop down lists.
2. Select the type of test tone using the **Signal Selection** slider.
3. Select the amplitude (volume) of the test tone using the **Amplitude** slider. The amplitude range is from -60 to +20dB. The default is -20dB.
4. Set the level for the test tone using the dB entry field or up/down arrows.
5. Set desired test tone duration using the **Signal Timeout** entry field.
6. For **Tone** signals, set the additional **Frequency** settings as explained in the next section.

7. Press the **Signal On** button to initiate the test signal on the selected unit and channel. The signal will continue using the specified settings until the **Signal Timeout** is reached, or the **Signal On** button is pressed again, whichever occurs first.

Tone Frequency Settings

Configure **Frequency** settings for tone tests as follows:

1. Select a tone frequency using the **Frequency** slider, or enter a frequency in the entry box.
2. Alternatively use the **Auto Sweep** button to sweep a range of frequencies using the **Begin Frequency, End Frequency, Increment, and Rate** settings. Select the **Repeat** checkbox if you want the sweep to continue in cycles.

NOTE: Use auto sweep to test the frequency response of a room and speakers, and to identify distortion or rattles produced by the speakers or speaker housings. Auto sweep moves the frequency of the signal generator from a low frequency to a high frequency at the specified rate. The **Frequency** slide control and readout reflect progress while the sweep is in progress. Sweep range is 20Hz—20kHz; increment range is 1Hz—20kHz, and the rate range is 10ms—2000ms. The default rate is 100ms.

3. Press the **Signal On** button to generate the tone test signal, or press the **Auto Sweep** button to initiate an auto sweep.

System Checks Tab

System Checks enable you to test network connections, telephone connections, microphones, and output channels for all units in a site. Running system checks can help identify component failures within the system using the tests you select on the System Check Config tab (described in the next section).

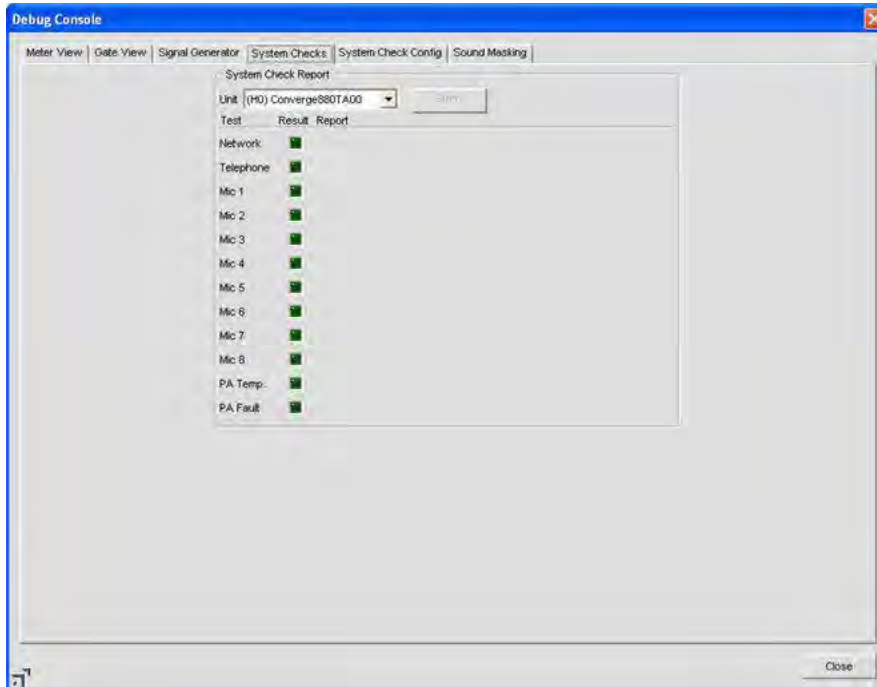

The test LEDs indicate test results as follows:

- **Red** = Test fails
- **Yellow** = Test not enabled in System Check Config
- **Green** = Test passes

System Check Config Tab

The **System Check Config** tab allows you to select and configure the diagnostic tests run on **System Checks** tab.

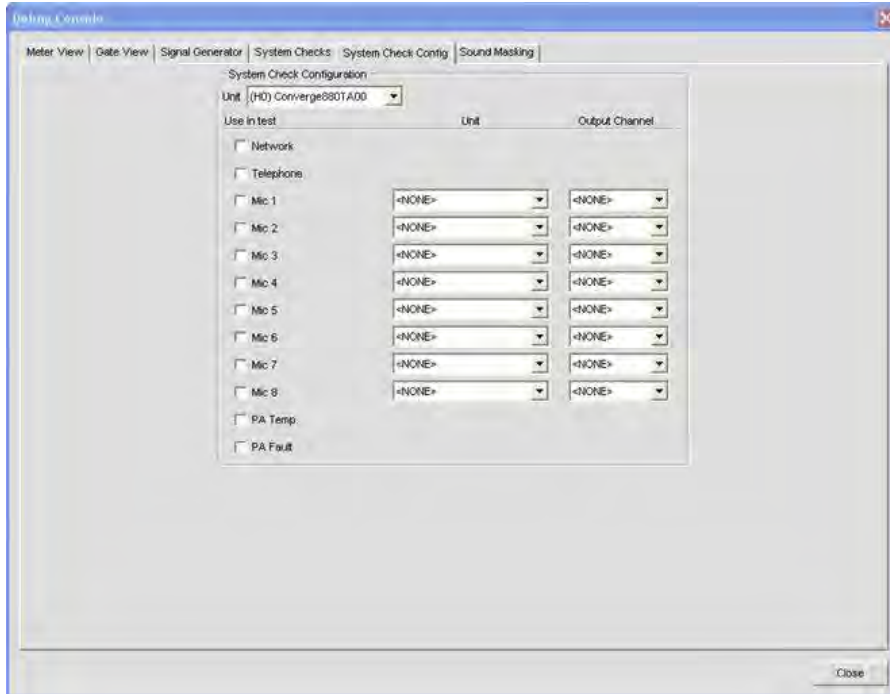

System Check Config settings include:

- **Unit (System Check Configuration):** Specifies the unit in the site that you want to test.
- **Network:** Select this check-box to test the IP configuration and network connectivity for the selected unit.
- **Telephone:** Select this check box to test **Telco/VoIP Rx** and/or **Telco/VoIP Tx** functionality .
- **Mic 1-4 (840T), Mic 1-8 (880, 880T, 880TA, 8i, SR 1212, SR 1212A):** Select the check box(es) for the mic input channels that you want to test.
- **Unit:** Specifies the unit that will provide test audio to the speaker.
- **Output Channel:** Specifies the output channel that will provide test audio to the speaker.

System Check Configuration - VH20

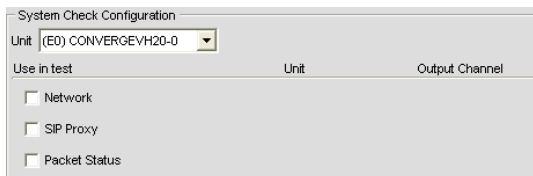

- **Network:** Select this check-box to test the IP configuration and network connectivity for the selected unit.
- **SIP Proxy:** Select this check box to test the Proxy 1 and 2 registration status
- **Packet Status:** Select this check box to the for packet loss

Select the tests you want to run using the **Use in test** check boxes, and select the unit(s) and output(s) (with speakers connected) using the **Unit** and **Output Channel** drop-down lists. Execute the selected tests by pressing the **Start** button on the **System Checks** tab.

Sound Masking Tab

Sound Masking is an Amplifier Out only feature consisting of three modes:

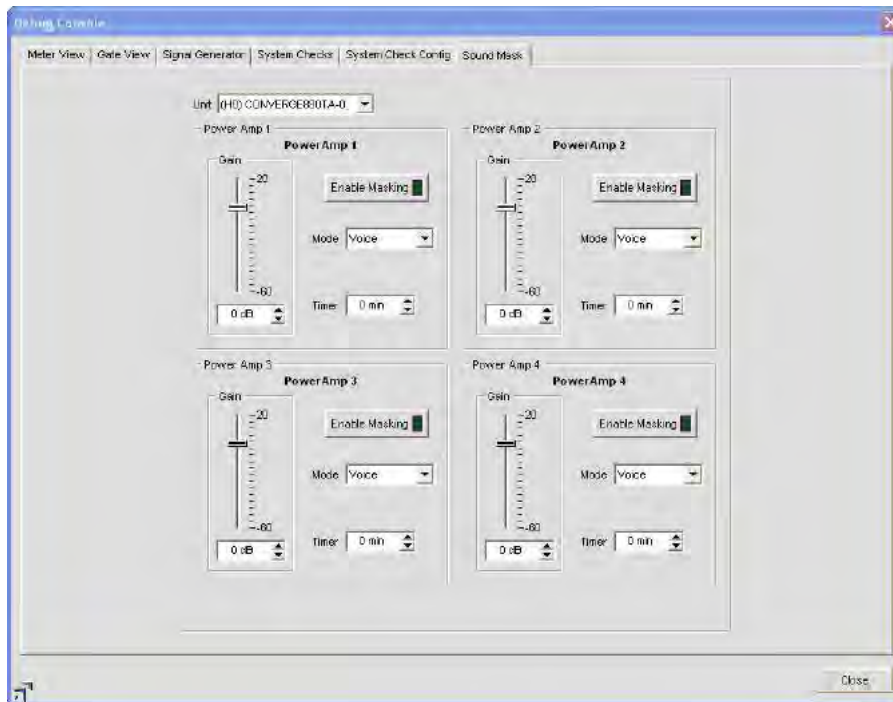

- **Off:** Disables the feature.
- **Voice:** Masking operates only in the range usually used when the target audio is vocal.
- **Wideband:** Masking operates throughout the audible range of the unit.

For additional information, please refer to the *Table of Contents* for these related topics:

- **Device Log**
- **Event Log**
- **Mic Input Settings**
- **Line Input Settings**
- **Telco/VoIP Rx Settings**
- **Telco/VoIP Tx Settings**
- **Output Settings**
- **Processing Settings**
- **Fader Settings**
- **Matrix Tab**

EXECUTE PRESETS

The Execute Presets command on the Services menu allows you to run presets while Console is in Configuration Mode.

NOTE: This command is not available while Console is in Preset Mode.

Accessing Execute Presets

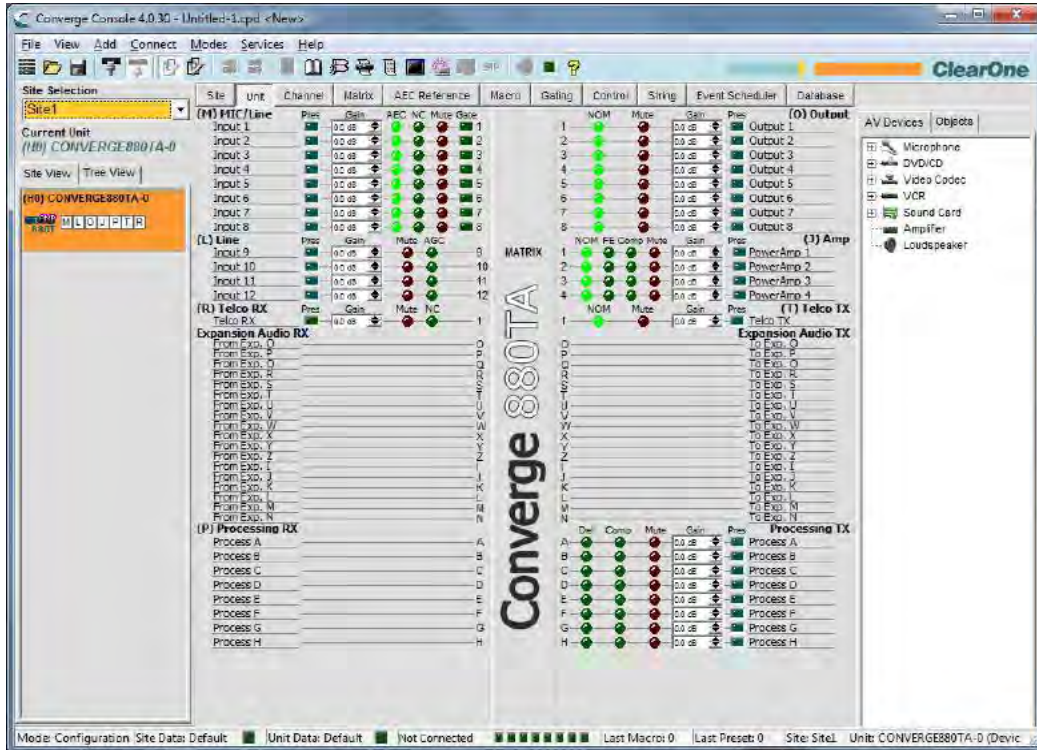

From the Console main screen, click on the **Services** menu and select **Execute Preset** as shown below.



The Execute Preset dialog appears as shown below.

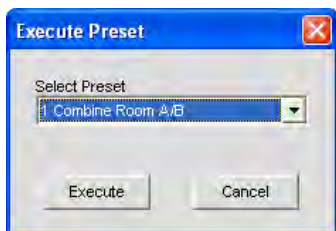

Select the preset you want to run from the drop-down list, then click **Execute** to run the preset or **Cancel** to return to Console. You can also use macros to execute presets or multiple presets simultaneously. For more information, see the *Macro Tab* topic.

For additional information, please refer to the *Table of Contents* for these related topics:

- **Preset Mode**
- **Services Menu**
- **Configuration Mode**
- **Preset Mode Overview**
- **Macro Tab**

APPENDIX A: APPLICATION PROGRAMMER'S INTERFACE

TYPE AND DEVICE IDS

Device Types and Device IDs by model are as follows:

Model	Device Type	Device ID Range
880	1	0-B
TH20	2	0-F
VH20	E	0-F
840T	3	0-B
8i	A	0-B
880T	D	0-B
880TA	H	0-B
SR 1212	G	0-B
SR 1212A	I	0-B
Beamforming Mic Array	N	0-F
CONNECT CobraNet	P	0-7
CONNECT Dante	S	0-7

CONVENTIONS

This guide uses the following typographic conventions to describe CONVERGE/CONVERGE Pro serial command syntax:

Convention	Description
<X>	Parameters enclosed in < > indicate a mandatory parameter
[X]	Parameters enclosed in [] indicate an optional parameter
1-8	Parameters separated by a '-' indicate a range of allowable values
4,7,9	Parameters separated by a ',' indicate a list of allowable values
EREF	Words in UPPERCASE bold indicate command text
Device	Indicates the device type and device number on the Expansion Bus. It is composed of a device type character and a device ID character.

COMMAND FORM DESCRIPTION

The structure of serial commands is as follows:

<Device Type> <Device ID> <Command> [Values] <Carriage Return>

indicates the start of a command line, the Carriage Return terminates a command.

NOTE: Serial commands can be either UPPERCASE or lowercase. Return values are always in UPPERCASE. In order for a command to be recognized by the RS-232 serial port, the command must be terminated by a carriage return.

For example, a command to disable mute for Mic Input 5 on a CONVERGE Pro 880 with a Device ID of 2 would have the command line **#12 MUTE 5 M 0**.

In this command line, 1 = the **Device Type** for CONVERGE 880, 2 = the **Device ID** for unit 2, **MUTE** = serial

command, 5 = the channel **Value**, M = the channel type **Value** for mic input channels, and 0 = the command **Value** that turns mute off.

If an asterisk (*) is placed in the **Device Type** or **Device ID** fields, the command will apply to all units or all devices respectively. For example, a command with a **Device Type** = 1 and a **Device ID** = * would apply the command to all CONVERGE 880 units. A command with a **Device Type** = * and a **Device ID** = 6 would apply the command to all units with a Device ID of 6.

If a command specifies “(Null to query in text)” in its **Value** table, leave a blank in the command line to query the current state of that value. For example, the command **#12 MUTE 5 M <blank>** would return the current mute state of Mic 2 on an 880 unit with a Device ID of 0.

GROUPS AND CHANNELS

All serial commands use common alpha and numeric designators to reference channel groups, channel types, and other command values. Also, different channel groups have different allowable channel ranges, as shown in the following table.

NOTE: CONNECT CobraNet/Dante are not applicable in the following table for all rows.

Group	Alpha	CONVERGE Pro 880 and SR 1212 Channel Range	CONVERGE Pro TH20 Channel Range	CONVERGE Pro 840T Channel Range	CONVERGE Pro 8i Channel Range	CONVERGE Pro 880T Channel Range	CONVERGE Pro 880TA Channel Range	CONVERGE SR 1212A Channel Range	CONVERGE Pro VH20 Channel Range	Beamforming Mic Array Channel Range
Inputs	I	1-12	1-2	1-8	1-12	1-12	1-12	1-12	1-2	N/A
Outputs	O	1-12	1-2	1-9 (9 is the power amp)	N/A	1-13 (13 is the power amp)	1-8	1-12	1-2	N/A
Mic Input	M	1-8	N/A	1-4	1-8	1-8	1-8	1-8	N/A	N/A
Beamforming Mic Array	V	N/A	N/A	N/A	N/A	N/A	N/A	N/A	N/A	1
Amplifier Output	J	N/A	N/A	N/A	N/A	N/A	1-4	1-4	N/A	N/A
Gating Group	G	1-4, A-F	N/A	1-4, A-F	1-4, A-F	1-4, A-F	1-4, A-F	1-4, A-F	N/A	A-F
Processing	P	A-F	N/A	A-D	A-F	A-F	A-F	A-F	N/A	N/A
Expansion Bus Audio Channels	E	O-Z, I-N	O-Z, I-N	O-Z, I-N	O-Z, I-N	O-Z, I-N	O-Z, I-N	O-Z, I-N	O-Z, I-N	O-Z, I-N
Line Inputs	L	9-12	1-2	5-8	9-12	9-12	9-12	9-12	1-2	N/A
Expansion Bus Reference Channels	A	1-8	1-8	1-8	1-8	1-8	1-8	1-8	1-8	1-8
GPIO	Y	0	0	0	0	0	0	0	0	N/A
Matrix	X	0	0	0	0	0	0	0	0	0
Fader	F	1-4	N/A	1-4	N/A	1-4	N/A	N/A	N/A	N/A
Presets	S	1-32	1-32	1-32	1-32	1-32	1-32	1-32	1-32	N/A
Macros	C	1-255	1-255	1-255	1-255	1-255	1-255	1-255	1-255	N/A
Transmit	T	N/A	1	1	N/A	1	1	N/A	N/A	N/A
Receive	R	N/A	1	1	N/A	1	1	N/A	N/A	N/A
Virtual Reference	B	1 – 4	N/A	1 – 4	N/A	1 – 4	1-4	N/A	N/A	N/A
Timed Events	Q	1-10	1-10	1-10	1-10	1-10	1-10	1-10	1-10	N/A
Web	W	0	0	0	0	0	0	0	0	N/A
PA Virtual Reference	H	N/A	N/A	N/A	N/A	N/A	1-4	1-4	N/A	N/A
VoIP Transmit	K	N/A	N/A	N/A	N/A	N/A	N/A	N/A	1	N/A
VoIP Receive	Z	N/A	N/A	N/A	N/A	N/A	N/A	N/A	1	N/A
USB Transmit	D	N/A	N/A	N/A	N/A	N/A	N/A	N/A	N/A	N/A
USB Receive	U	N/A	N/A	N/A	N/A	N/A	N/A	N/A	N/A	N/A

METER TYPE DEFINITIONS TABLE

ALPHA	Level Position for:								
	Mics	Beam-forming Mic Array	Line Inputs	Outputs	Telco TX	Telco Rx	Faders	Processors	Power Amp.
I	Input level	Input level	Input level	Input level	Post Gain level	Input Level	N/A	Level into Compressor	Input Level Post NOM
A	Level post-gain adjustment, but pre-filter	Level post-gain adjustment, but pre-filter	Post Gain level	Post Gain level	Post Limiter level	Post Gain level	Level Post gain Adjustment	Level Post Compressor	Output Level Post Gain
N	Level post-filter but pre-gate (non-gated level)	N/A	N/A	N/A	N/A	Level after Gain Stage	N/A	Level Post Gain Stage	Feedback Max Auto Gain
G	Level post-gate (gated level)	Level post-gate (gated level)	N/A	N/A	N/A	N/A	N/A	N/A	Compressor Attenuation
R	Echo Return Loss (Not SR 1212 / SR 1212A)	Echo Return Loss	N/A	N/A	N/A	N/A	N/A	N/A	Level Pre Compressor
E	Echo Return Loss Enhancement (Not SR 1212 / SR 1212A)	Echo Return Loss Enhancement	N/A	N/A	N/A	N/A	N/A	N/A	Level Post Compressor
T	ERL + ERLE (Not SR 1212 / SR 1212A)	ERL + ERLE	N/A	N/A	N/A	N/A	N/A	N/A	Adaptive Gain
C	AGC	N/A	AGC	N/A	N/A	N/A	N/A	N/A	Level of Adaptive Gain Noise Floor
Y	Pre AGC peak level meter	N/A	Pre AGC peak level meter	N/A	N/A	N/A	N/A	N/A	Level Post Mute/Gain Pre EQ
Z	Post AGC peak level meter	N/A	Post AGC peak level meter	N/A	N/A	N/A	N/A	N/A	N/A
B	Ambient	N/A	N/A	N/A	N/A	N/A	N/A	N/A	N/A

SERIAL COMMAND INDEX

AA – Auto Answer Enable / Disable	260
AAMB – Adaptive Ambient Mode	260
AARINGS – Number of Rings to Auto Answer On	260
ACONN – Audible Connect / Disconnect Indication	260
ACONNLVL – Audible Connect / Disconnect Level	261
AD – Auto Disconnect Enable / Disable	261
ADCLIP – Audio Clipping	261
ADPRESENT – Audio Presence	262
AEC – Acoustic Echo Cancellation Enable / Disable	262
AGC – Automatic Gain Control	262
AGCSET – Automatic Gain Control Adjust	263
AMBLVL – Ambient Level Adjust	263
AMXDUET – Use AMX Duet Discovery	263
AUDIOMASTER – Expansion Bus Audio Master Mode	263
AV – Adaptive Volume	263
AVG – Adaptive Volume Gain	264
AVR – Adaptive Volume Reference	264
AVRT – Adaptive Volume Ratio	264
AVT – Adaptive Volume Threshold	264
BAUD – Baud Rate	264
BFBINFO – Beamforming Array Beam Information	265
BFLED – Beamforming Mic LED Mode	266
BFMODE – Sets/Reports Beamforming Mic Mode	265
BFMUTEMACRO – Define Macros that Run When Beamforming Mic Mute Button Is Pressed	266
BFPOS – Beamforming Array Position in Auto Mode	265
BFZONE – Manually Disables/Enables Beamforming Mic Zones	265
CALLDUR – Call Duration	266
CALLERID – Reports Caller ID Information	266
CALLSTATUS – Report the Status of VoIP Channels	324
CGROUP – Compressor Group Select	267
CHAIR0 – Chairman Override Mode	267
CLEARFFECT – ClearEffect Wide Band Telco Emulation	267
CLOCK – Clock Set	267
CNETADDR – CobraNet Board IP Address	268
CNETCONDUCTOR – CobraNet Port Is Conductor	268
CNETCONTACT – CobraNet Board Contact	268
CNETCPRIO – CobraNet Conductor Priority	268
CNETLINK – CobraNet Port Is Linked to a Remote CobraNet Device	268
CNETLOC – CobraNet Board Location	268
CNETMAC – CobraNet Board MAC Address	269
CNETNAME – CobraNet Board Name	269
CNETRXBNUM – CobraNet Rx Bundle Number	269
CNETRXSTATUS – CobraNet Rx Bundle Status	269

CNETTXBNUM – CobraNet Tx Bundle Number	269
CNETTXDEPTH – CobraNet Tx Bundle Bit Depth	270
CNETTXLATENCY – CobraNet Tx Bundle Maximum Unicast	270
CNETTXMAXUNI – CobraNet Tx Bundle Latency	270
CNETTXSTATUS – CobraNet Tx Bundle Status	270
CNETVER – CobraNet Tx Board F/W Version	270
COMPDLY – Compressor Delay	271
COMPDLYEN – Compressor Delay Enable	271
COMPERSIST – CobraNet Persistence	271
COMPRESS – Compressor Adjust	271
COMPSEL – Compression Select	271
CONFCANCEL – Cancels a Conference Call Bridge	324
CONFCOMPLETE – Completes a Conference Call Bridge	324
CONFSTART – Initiates a 3-Way Conference Call	325
COUNTRY – Country Selection	272
CTRLMASTER – Control Master Mode	272
DANTEADDR – Dante Board IP Addresses	272
DANTEAPPVER – Dante Internal Application Version	273
DANTEBRIDGE – Ethernet IP, Listen and Destination Ports for Dante Events	273
DANTECAPVER – Dante Compatibility Version	273
DANTEEVBRD – Name of the Dante Board to Send Events To	273
DANTEEVENT – Dante Event (To Dante device)	273
DANTEINCHAN – Dante Input Channel Name	274
DANTELINK – Dante LINK and DUPLEX Status	274
DANTEMAC – Dante Board MAC Addresses	274
DANTEMVER – Dante Mondo File Version	274
DANTENAME – Dante Board Name	275
DANTEOUTCHAN – Dante Output Channel Name	275
DANTERESET – Dante Reset	275
DANTEUPDATE – Update Dante Parameters	275
DANTEVER – Dante F/W Version	275
DECAY – Decay Adjust	272
DEFAULT – Default The Unit	275
DELAY – Delay Adjust	275
DELAYSEL – Delay Select	276
DEVICENAME – Argument Identification Label	276
DEVICESUBTYPE – Sets the Subtype of a Connected Device	276
DEVICETYPE – Sets the Type of a Connected Device	276
DFLTM – Default Meter	276
DIAG – Diagnostic Commands	277
DIAL – DTMF Dialing	277
DIDCONFLICT – Dante F/W Version	277
DID – Device ID	277
DIGMICSEN – Enable/Disable Digital Mics	278
DIGMICS – Number of Digital Mics on a CONVERGE Pro Board	278

DTMFLVL – DTMF Tone Level	278
DTONELVL – Dial Tone Level	278
DUPDATE – Download Update	279
DVER – Command Dictionary Version	279
ENETADDR – Ethernet Port IP Address	279
ENETDHCP – Ethernet DHCP Selection	279
ENETDNSA2 – Ethernet DNS Server Address 2	280
ENETDNSA – Ethernet DNS Server Address	279
ENETDNS – Ethernet DNS Selection	279
ENETDOMAIN – Ethernet Domain Argument	280
ENETGATE – Ethernet Default Gateway Address	280
ENETSUBN – Ethernet Subnet Mask	280
ENETVLAN – Enable VLAN Tagging	280
ENETVLANID – VLAN ID	280
ENETVLANPRI – VLAN Priority	280
EREF – Expansion Bus Reference	281
EVENT – Run Scheduled Event	281
FEB – Feedback Elimination Bandwidth	281
FEDR – Feedback Elimination Dynamic Node Reset	281
FE – Feedback Elimination Enable	281
FEF – Feedback Elimination Fixed Filter	282
FEG – Feedback Elimination Auto Gain Max	282
FEGL – Feedback Elimination Gain Level	282
FELD – Feedback Elimination Lock Depth	282
FEM – Feedback Elimination Mode	282
FEN – Feedback Elimination Nodes	283
FER – Feedback Elimination Node Reset	283
FERNG – Feedback Elimination Ring Elimination Mode	283
FESC – Feedback Elimination Setup Complete	283
FES – Feedback Elimination Setup	283
FILTER – Filter Adjust	284
FILTSEL – Filter Select	284
FLOW – Flow Control	285
FMP – First Mic Priority Mode	285
GAIN – Gain Adjustment	285
GATE – Gate Status	285
GHOLD – Gate Hold Time Adjust	285
GMODE – Gating Mode	286
GPIOSTATUS – General Purpose Status	286
GRATIO – Gate Ratio Adjust	286
GREPORT – Gate Report	286
GRPSEL – Gating Group Select	287
HDAEC – Enables/Disables HD AEC mode	287
HDAECMODE – Set/Report HD AEC mode	287
HDDREFSEL1 – Reference Select for Mono Channel Acoustic Echo Cancellation Block	287

HDDREFSEL2 – Reference Select for Stereo Channel Acoustic Echo Cancellation Block	287
HDNLP – Non Linear Processing Adjust	288
HOLD – Places a Call on Hold	325
HOOKD – Hook Flash Duration	288
HOOK – Hook Flash	288
LABEL – Label	288
LCDCONTRAST – LCD Contrast	288
LMO – Last Mic On Mode	289
LOCALNUM – Local Number	289
LOCBLDG – Location: Building	289
LOCCITY – Location: City	289
LOCCNTRY – Location: Country	289
LOCCOMP – Location: Company	289
LOCREGION – Location: Region	290
LOCROOM – Location: Room	290
LOCSITENAME – Location: Site Argument	290
LOCSTATE – Location: State	290
LOGMASK – Device Log Mask	291
LVL – Level	291
LVLREPORTEN – Level Report Enable	292
LVLREPORT – Level Report	291
MACRO – Macro Execution/Reporting	292
MANUFACTURER – Manufacturer Identification Label	292
MAX – Maximum Gain Setting	292
MCGAIN – Multi-Channel Gain	293
MCMINMAX – Multi-Channel Min and max Gain Setting	293
MC – Multi-Channel Mode	293
MCMUTE – Multi-Channel Min and Max Gain Setting	294
MCRAMP – Multi-Channel Ramp	294
MINMAX – Minimum and Maximum Gain Setting	295
MIN – Minimum Gain Setting	294
MLINE – Mic / Line Coarse Gain Setting	295
MMAX – Maximum Number of Microphones	295
MODEL – Model Identification Label	295
MTRXCLEAR – Clear Matrix	296
MTRX – Matrix Routing	296
MTRXTYPE – Select Pre-AEC Gated or Non-Gated Routing	296
MULTILNEN – VoIP Multi-Line Enable	325
MULTILNSTAT – VoIP Multi-Line Status	325
MUTE – Mute	297
NAME – Unit Name (NETBIOS Name)	297
NCD – Noise Cancellation Depth Adjust	297
NCSEL – Noise Cancellation Select	297
NLP – Non Linear Processing Adjust	297
NOM – Number of Open Microphones Mode	298

NTPSRV – NTP Network Time Server Address	298
NULL – Null the Telephone Line	298
OFFA – Off Attenuation Mode	298
ORDER – Number of board to the Top and End of the Expansion Bus chain	298
PAA – PA Adaptive Mode	299
PACEN – PA Softclipper Enable	299
PAENERGY – PA Energy-saver mode	299
PAEQEN – PA EQ Filter Enable	299
PAEQRST – PA EQ Filter Reset	299
PAEQSET – PA EQ Filter Set	300
PAFLT – PA Fault	300
PAIMPED – PA Output Impedance	300
PALEN – PA Limiter Enable	300
PALT – PA Limiter Threshold	301
PANGAT – PA Noise Gate Activation Timer	301
PANGEN – PA Noise Gate Enabled	301
PANGF – PA Noise Gate Filter	301
PANGM – PA Noise Gate Mode	301
PANGT – PA Noise Gate Threshold	302
PAPOL – Polarity Switch	302
PARST – PA Reset	302
PASME – PA Sound Mask Enable	302
PASML – PA Sound Mask Level	302
PASMM – PA Sound Mask Mode	303
PASMT – PA Sound Mask Timer	303
PATO – PA Thermal Overload	303
PBDIAL – Dial a PB Entry by Argument	303
PHONEBOOKADD – Adds an Entry to the Phonebook	303
PHONEBOOKCNT – Counts Entries in the Phonebook	304
PHONEBOOKDEL – Deletes an Entry in the Phonebook	304
PHONEBOOKREAD – Queries the Phonebook by Index	304
PP – Phantom Power	304
PRESET – Preset Execution/Reporting	304
PRGSTRING – Program String	305
PROXSTAT – Proxy Registration Status	305
PROXYTYPE – Set/Get Proxy Type	305
PTTTHRESHOLD – Push to Talk Threshold	305
PUSHTOTALK – Push to Talk	306
RAMP – Ramp Gain Adjustment	306
REDIAL – Redial the Last Number	306
REFSEL – Reference Select for PA Adaptation & AEC	306
REFSET – Reference Channel Set Up	306
RESET – Reset	307
RINGEREN – Audible Ring Enable	307
RINGERLVL – Audible Ring Level	307

RINGERSEL – Audible Ring Melody Selection	307
RINGERTEST – Audible Ring Melody Test	307
RINGMOD – Ring Cadence Mode	308
RINGOFF – Ring Cadence Off Time	308
RINGON – Ring Cadence On Time	308
RING – Ring Indication	307
RXBOOST – Receive Boost	308
RXBSTEN – Receive Boost Enable	309
SERECHO – Serial Echo	309
SFTYMUTE – Safety Mute	309
SIGGENEN – Signal Generator Enable	309
SIGGEN – Signal Generator	309
SIGGENSWEEP – Signal Generator Sweep	310
SIGTOUT – Signal Generator Time Out	310
SLVL – Speech Level Control	310
SMTPSRV – SMTP Mail Server Address	310
SNMPMNGRIP – SNMP Manager Host IP Address	311
SNMPMNGRPORT – SNMP Manager Notification Port	311
SNMPREADCOMM – SNMP Read Community String	311
SNMPWRITECOMM – SNMP Write Community String	311
SPEEDDIAL – Speed Dial a Number	311
STRING – String Execution	311
SYSCHECKS – System Checks	312
SYSRESULT – System Check Result	313
TAMODE – Telco Adapt Mode	314
TELCOLVLCtrl – Telco RX Level Control Enable / Disable	314
TELOVER – Telco Current Overload	314
TE – Telco Enable	314
TIMELOCALE – Time Locale Settings	314
TOUT – Time Out Select	315
TRASCANCEL – Cancels a Transferred Call	326
TRANSCOMPLETE – Completes a Transferred Call	326
TRANSSTART – Initiate an Attended or Unattended Call Transfer	326
UID – Unit ID	315
VER - Version	315
VE – VoIP Enable	326
XAA – Auto Answer Enable/Disable	315
XAAMB – Adaptive Ambient Mode	315
XAARINGS – Number of Rings to Auto Answer On	316
XACONN – Audible Connect / Disconnect Indication	316
XACONNLVL – Audible Connect / Disconnect Level	316
XAMBLVL – Ambient Level Adjust	315
XCALLDUR – Call Duration	316
XCALLERID – Reports Caller ID Information	316
XCGROUP – Compressor Group	317

XCHAIR0 – Chairman Override Mode	317
XCOMPRESS – Compressor Adjust	317
XCOMPSEL – Compressor Enable	317
XDECAY – Decay Adjust	318
XDELAY – Audio Delay	318
XDELAYSEL – Audio Delay Enable	318
XDELAYSEL – Audio Delay Enable	318
XDIAL – DTMF Dialing	319
XDTMFLVL – DTMF Tone Level	319
XDTONELVL – Dial Tone Level	319
XGHOLD – Gate Hold Time Adjust	319
XGMODE – Gating Mode	319
XGOVER – Gating Override	320
XGRATIO – Gate Ratio Adjust	320
XGRPSEL – Gating Group Select	320
XHOOKD – Hook Flash Duration	320
XHOOK – Hook Flash	320
XLOCALNUM – Local Number	321
XOFFA – Off Attenuation Mode	321
XPBDIAL – Dial a PB Entry by Name	321
XREDIAL – Dial the last number again	321
XRINGEREN – Audible Ring Enable	322
XRINGERLVL – Audible Ring Level	322
XRINGERSEL – Audible Ring Melody Selection	322
XRINGERTEST – Audible Ring Melody Test	322
XRING – Ring Indication	321
XSLVL – Speech Level Control	322
XSPEEDDIAL – Speed Dialing	323
XTE – Telco Enable	323

SERIAL COMMANDS

Serial commands are shown in bold, followed by the command form and argument details.

AA – Auto Answer Enable / Disable

This command selects/reports the setting of auto answer.

Command Form: **DEVICE AA** <Channel> [Value]

Argument	Type	Size	Values	Units
Channel	Channel	1	See Groups and Channels	-
Group	Group	1	17 (R)	-
Value	Unsigned Integer	2	0 = Off 1 = On 2 = Toggle (Null to query in text)	-

AAMB – Adaptive Ambient Mode

This command selects/reports the setting of adaptive ambient.

Command Form: **DEVICE AAMB** <Channel> [Value]

Argument	Type	Size	Values	Units
Channel	Channel	1	See Groups and Channels	-
Group	Group	1	3 (M)	-
Value	Unsigned Integer	2	0 = Off 1 = On 2 = toggle (Null to query in text)	-

AARINGS – Number of Rings to Auto Answer On

This command selects/reports the setting of the number of rings to auto answer.

Command Form: **DEVICE AARINGS** <Channel> [Value]

Argument	Type	Size	Values	Units
Channel	Channel	1	See Groups and Channels	-
Group	Group	1	17 (R)	-
Value	Unsigned Integer	2	2 - 4 (Null to query in text)	-

ACONN – Audible Connect / Disconnect Indication

This command selects/reports the status of the audible connect / disconnect indication.

Command Form: **DEVICE ACONN** <Channel> [Value].

Argument	Type	Size	Values	Units
Channel	Channel	1	See Groups and Channels	-
Group	Group	1	17 (R)	-
Value	Unsigned Integer	2	0 = Off 1 = On 2 = Toggle (Null to query in text)	-

ACONNLVL – Audible Connect / Disconnect Level

This command selects/reports the audible connect / disconnect indicator's level.

Command Form: *DEVICE ACONNLVL* <Channel> [Value]

Argument	Type	Size	Values	Units
Channel	Channel	1	See Groups and Channels	-
Group	Group	1	17 (R)	-
Value	Signed Float	2	-12.00 – 12.00 (Null to query in text)	dB

AD – Auto Disconnect Enable / Disable

This command selects/reports the setting of auto disconnect.

Command Form: *DEVICE AD* <Channel> [Value]

Argument	Type	Size	Values	Units
Channel	Channel	1	See Groups and Channels	-
Group	Group	1	17 (R)	-
Value	Unsigned Integer	2	0 = Off 1 = Loop Drop 2 = Call Progress 3 = Loop Drop + Call Progress (Null to query in text)	-

ADCLIP – Audio Clipping

This command reports the channels that are currently clipping their audio signals. **This command is read only.** This command is implemented only for inputs.

Command Form: *DEVICE ADCLIP* [Values]

Argument	Type	Size	Values
Value	Bit Map of Inputs	2	XXXX XXXX XXXX XXXX → Input 1 (lsb) to 12 (msb) → Reserved (Null to query in text)
	Bit Map of Outputs	2	XXXX XXXX XXXX XXXX → Output 1 (lsb) to 13 (msb) ... → Reserved
	Bit Map of Processors	2	XXXX XXXX XXXX XXXX → Processor A (lsb) to H (msb) ----- → Reserved
	Bit Map of Faders	1	XXXX XXXX ----- → Faders 1 (lsb) to 4 (msb) ----- → Reserved
	Bit Map of Telco	1	XXXX XXXX → Telco RX → Telco TX ----- → Reserved

ADPRESENT – Audio Presence

This command displays the channels that currently have valid audio signals present. **This command is read only.**

Command Form: *DEVICE* **ADPRESENT** [Values]

Argument	Type	Size	Values
Value	Bit Map of Inputs	2	XXXX XXXX XXXX XXXX → Input 1 (lsb) to 12 (msb) → Reserved (Null to query in text)
	Bit Map of Outputs	2	XXXX XXXX XXXX XXXX → Output 1 (lsb) to 13 (msb) → Reserved
	Bit Map of Processors	2	XXXX XXXX XXXX XXXX → Processor A (lsb) to H (msb) ----- → Reserved
	Bit Map of Faders	1	XXXX XXXX ----- → Faders 1 (lsb) to 4 (msb) ----- → Reserved
	Bit Map of Telco	1	XXXX XXXX → Telco RX → Telco TX ----- → Reserved

AEC – Acoustic Echo Cancellation Enable / Disable

This command selects/reports the setting of Acoustic Echo Canceller.

Command Form: *DEVICE* **AEC** <Channel> [Value]

Argument	Type	Size	Values	Units
Channel	Channel	1	See Groups and Channels	-
Group	Group	1	3 (M)	-
Value	Unsigned Integer	2	0 = Off 1 = On 2 = Toggle (Null to query in text)	-

AGC – Automatic Gain Control

This command selects/reports the setting of automatic gain control.

Command Form: *DEVICE* **AGC** <Channel> <Group> [Value]

Argument	Type	Size	Values	Units
Channel	Channel	1	See Groups and Channels	-
Group	Group	1	1, 3, 7 (I, M, L)	-
Value	Unsigned Integer	2	0 = Off 1 = On 2 = Toggle (Null to query in text)	-

AGCSET – Automatic Gain Control Adjust

This command selects/reports the settings of the Automatic Gain Control.

Command Form: **DEVICE AGCSET** <Channel> <Group> [Threshold Target Attack Gain]

Argument	Type	Size	Values	Units
Channel	Channel	1	See Groups and Channels	-
Group	Group	1	1, 3, 7 (I, M, L)	-
Threshold	Signed Integer	1	-50 – 0 (Null to query in text)	dB
Target	Signed Integer	1	-30 – 20	dB
Response Time	Unsigned Float	2	0.10 – 10.00	S
Gain	Unsigned Float	2	0.00 – 18.00	dB

AMBLVL – Ambient Level Adjust

This command selects/reports the ambient level.

Command Form: **DEVICE AMBLVL** <Channel> [Value]

Argument	Type	Size	Values	Units
Channel	Channel	1	See Groups and Channels	-
Group	Group	1	3 (M)	-
Value	Signed Float	2	-80.00 – 0.00 (Null to query in text)	dB

AMXDUET – Use AMX Duet Discovery

This command sets and reports the status of AMX Duet Discovery.

Command Form: **DEVICE AMXDUET** [Value]

Argument	Type	Size	Values	Units
Value	Unsigned Integer	4	0 = Off 1 = On 2 = toggle (Null to query in text)	-

AUDIOMASTER – Expansion Bus Audio Master Mode

This command reports the mode of the unit for control of the expansion bus audio.

Command Form: **DEVICE AUDIOMASTER** [Value]

Argument	Type	Size	Values	Units
Value	Unsigned Integer	4	1 = Master 2 = Slave (Null to query in text)	-

AV – Adaptive Volume

This command enables/disables adaptive volume tracking on a power amplifier channel.

Command Form: **DEVICE AV** <Channel> <Group> [Value]

Argument	Type	Size	Values	Units
Channel	Channel	1	See Groups and Channels	-
Group	Group	1	23 (J)	-
Value	Signed Float	2	0 = Off 1 = On 2 = Toggle (Null to query in text)	-

AVG – Adaptive Volume Gain

This command sets the maximum gain setting that the algorithm will not exceed.

Command Form:

Argument	Type	Size	Values	Units
Channel	Channel	1	See GroupsAndChannels	-
Group	Group	1	23 (J)	-
Value	Signed Short	2	0.00 to +18.00 (Null to query in text)	dB

AVR – Adaptive Volume Reference

This command selects/reports the microphone or expansion bus reference channel to be used for adaptive volume tracking on a power amplifier channel.

Command Form: **DEVICE AVR** [CHANNEL] [GROUP]

Argument	Type	Size	Values	Units
Channel	Channel	1	(M) 1-8 (E) 1-18 (Null to query in text)	-
Group	Group	1	3, 6 (M or E)	-

AVRT – Adaptive Volume Ratio

This command sets the ratio at which gain will be automatically applied based upon the ambient level in the reference microphone. Example: A 1:1 setting would apply 1 dB of gain for every 1dB rise in ambient level of the reference microphone up to the Max Gain setting.

Command Form: **DEVICE AVRT** <Channel> <Group> [Value]

Argument	Type	Size	Values	Units
Channel	Channel	1	See GroupAndChannels	-
Group	Group	1	23 (J)	-
Value	Unsigned Short	2	0 = 2:1 1 = 1:1 2 = 1:2 (Null to query in text)	Ratio

AVT – Adaptive Volume Threshold

This command sets the level at which the adaptive volume algorithm will be activated. This value is referenced to the noise floor of the channel and the target above ambient for the adaptive volume to reach.

Command Form: **Device AVT** <Channel> <Group> [Value]

Argument	Type	Size	Values	Units
Channel	Channel	1	See GroupAndChannels	-
Group	Group	1	23 (J)	-
Value	Signed Short	2	-80.00 to 0.00 (Null to query in text)	-

BAUD – Baud Rate

This command selects/reports the baud rate of the serial port.

Command Form: **DEVICE BAUD** [Value]

Argument	Type	Size	Values	Units
Value	Unsigned Integer	4	9600, 19200, 38400, 57600, 115200 (Null to query in text)	-

BFBINFO – Beamforming Array Beam Information

This command reports the given Beamforming Array's current active beams. **This command is read only.**

Command Form: *DEVICE* **BFBINFO** [Value]

Argument	Type	Size	Values	Units
Value	Integer	4	String with binary representation of the status of the eight (maximum future #) beams. 0 = Beam Inactive 1 = Beam Active (Null to Query in Text)	-

BFMODE – Sets/Reports Beamforming Mic Mode

This Sets the Beamforming Mic to Table Top, Wall Mount, Ceiling Mount, or Auto (Let the Beamforming Mic decide).

Command Form: *DEVICE* **BFMODE** <Channel> <Group> <Value>

Argument	Type	Size	Values	Units
Channel	Channel	1	See Groups and Channels	-
Group	Group	1	29 (V)	-
Value	Integer	2	1 = Auto (Default) 2 = Table Top 3 = Ceiling Mount 4 = Wall Mount (Null to Query in Text)	-

BFPOS – Beamforming Array Position in Auto Mode

This command reports the given Beam Former Array's Position if the BFMODE is Auto. **This command is read only.**

Command Form: *DEVICE* **BFPOS** [Value]

Argument	Type	Size	Values	Units
Value	Integer	4	2 = Table Top 3 = Ceiling Mount 4 = Wall Mount (Null to Query in Text)	-

BFZONE – Manually Disables/Enables Beamforming Mic Zones

For each Mode of a Beamforming Mic manually Enable or Disable each of the Mic Zones.

Command Form: *DEVICE* **BFZONE** <Channel> <Group> [Zone 1] [Zone 2] [Zone 3] [Zone 4] [Zone 5] [Zone 6]

Argument	Type	Size	Values	Units
Channel	Channel	1	See Groups and Channels	-
Group	Group	1	29 (V)	-
Zone 1	Unsigned Character	1	0 = Zone Disabled 1 = Zone Enabled (Null to Query in Text)	-
Zone 2	Unsigned Character	1	0 = Zone Disabled 1 = Zone Enabled (Null to Query in Text)	-
Zone 3	Unsigned Character	1	0 = Zone Disabled 1 = Zone Enabled (Null to Query in Text)	-
Zone 4	Unsigned Character	1	0 = Zone Disabled 1 = Zone Enabled (Null to Query in Text)	-
Zone 5	Unsigned Character	1	0 = Zone Disabled 1 = Zone Enabled (Null to Query in Text)	-
Zone 6	Unsigned Character	1	0 = Zone Disabled 1 = Zone Enabled (Null to Query in Text)	-

BFMUTEMACRO – Define Macros that Run When Beamforming Mic Mute Button Is Pressed

Define which macros to run on which CONVERGEPro board to Mute and Un-Mute groups of Beamforming Mics when the specified Beamforming Mic's Mute button is pressed. This allows pressing a single button to Mute or Un-Mute multiple Beamforming Mics. If the Macro numbers are zero (default) then ALL Beam Former Mics in the system will be Muted or Un-Muted.

Command Form: DEVICE **BFMUTEMACRO** [Type ID] [Device ID] [Mute On Macro] [Mute Off Macro]

Argument	Type	Size	Values	Units
Type ID	Integer	1	Type ID of board where the Mute On and Mute Off Macros are defined (Null to Query in text)	-
Device ID	Integer	1	Device ID of board where the Mute On and Mute Off Macros are defined	-
Mute On Macro	Integer	1	See 14(C) in Groups and Channels	-
Mute Off Macro	Integer	1	See 14(C) in Groups and Channels	-

BFLED – Beamforming Mic LED Mode

This command sets/reports the mode of the Mute Button LEDs on a Beamforming Mic.

Command Form: DEVICE **BFLED** [Value]

Argument	Type	Size	Values	Units
Value	Integer	4	0 = OFF (Always not lit) 1 = Steady Red when Muted – Steady Blue when Un-Muted (Default) 2 = Blinking Red when Muted – Steady Blue when Un-Muted (Null to Query in text)	-

CALLDUR – Call Duration

This command returns current call duration. If no call is active, this command returns 0. At the time of call termination, this command will automatically be sent out to report call duration. **This command is read only.**

Command Form: DEVICE **CALLDUR** <Channel> <Duration>

Argument	Type	Size	Values	Units
Channel	Channel	1	See Groups and Channels	-
Group	Group	1	17 (R)	-
Reserved		2	0	-
Duration	String	8	String of format HR:MN:SS	-

CALLERID – Reports Caller ID Information

This command reports Caller Identification Information. **This command is reportable only. It cannot be queried or set.**

Command Form: DEVICE **CALLERID** <Channel> <Number> <Argument>

Argument	Type	Size	Values	Units
Channel	Channel	1	See Groups and Channels	-
Group	Group	1	17 (R)	-
Reserved	Unsigned Integer	2	0	-
Number	String	16	1 – 16 chars	-
Label	String	16	1 – 16 chars	-

CGROUP – Compressor Group Select

This command selects/reports the setting of the compressor group.

Command Form: *DEVICE* **CGROUP** <Channel> [Value]

Argument	Type	Size	Values	Units
Channel	Channel	1	See Groups and Channels	-
Group	Group	1	5 (P)	-
Value	Unsigned Integer	2	0 = none 1 – 4 (Null to query in text)	Com- pressor Group

CHAIRO – Chairman Override Mode

This command selects/reports the setting of chairman override.

Command Form: *DEVICE* **CHAIRO** <Channel> [Value]

Argument	Type	Size	Values	Units
Channel	Channel	1	See Groups and Channels	-
Group	Group	1	3 (M)	-
Value	Unsigned Integer	2	0 = Off 1 = On 2 = Toggle (Null to query in text)	-

CLEAREFFECT – ClearEffect Wide Band Telco Emulation

This command enables / disables or reports the current status of the ClearEffect.

Command Form: *DEVICE* **CLEAREFFECT** <Channel> [Value]

Argument	Type	Size	Values	Units
Channel	Channel	1	See Groups and Channels	-
Group	Group	1	17 (R)	-
Value	Unsigned Integer	2	0 = Off 1 = On 2 = Toggle (Null to query in text)	-

CLOCK – Clock Set

This command sets or reports the current time.

Command Form: *DEVICE* **CLOCK** [Date Month Year Hours Minutes Seconds Day]

Argument	Type	Size	Values	Units
Date	Unsigned Integer	1	1 – 31	-
Month	Unsigned Integer	1	1 – 12	-
Year	Unsigned Integer	2	2000 – 2099 (NULL to Query in Text)	-
Hours	Unsigned Integer	1	00 – 23	-
Minutes	Unsigned Integer	1	00 – 59	-
Seconds	Unsigned Integer	1	00 – 59	-
Day of Week	Unsigned Integer	1	1 = Sunday 2 = Monday 3 = Tuesday 4 = Wednesday 5 = Thursday 6 = Friday 7 = Saturday	-

CNETADDR – CobraNet Board IP Address

This command selects/reports the IP address of the Ethernet port on the CONNECT CobraNet Bridge board.

Command Form: *DEVICE* **CNETADDR** [Value]

Argument	Type	Size	Values	Units
Value	IP Address	4	(Null to query in text)	-

CNETCONDUCTOR – CobraNet Port Is Conductor

This command reports if the CobraNet Port is a Conductor. **This command is Query ONLY and may be sent asynchronously.**

Command Form: *DEVICE* **CNETCONDUCTOR** [Value]

Argument	Type	Size	Values	Units
Value	Integer	4	0 = CobraNet Port is NOT a Conductor 1 = CobraNet Port IS a Conductor (Null to query in text)	-

CNETCONTACT – CobraNet Board Contact

This command sets/reports the assigned contact of the CONNECT CobraNet Bridge board.

Command Form: *DEVICE* **CNETCONTACT** [Value]

Argument	Type	Size	Values	Units
Value	String	54	1 - 54 Characters (Null to query in text)	-

CNETCPRIO– CobraNet Conductor Priority

This command sets/reports the CobraNet Conductor Priority.

Command Form: *DEVICE* **CNETCPRIO** [Value]

Argument	Type	Size	Values	Units
Value	Integer	4	0 – 255 (Default = 32) (Null to query in text)	-

CNETLINK– CobraNet Port Is Linked to a Remote CobraNet Device

This command reports if the CONNECT CobraNet Port is currently Linked, Full Duplex, and Receiving Packets.

This command is Query ONLY and may be sent asynchronously.

Command Form: *DEVICE* **CNETLINK** [Bit Pattern]

Argument	Type	Size	Values	Units
Bit Pattern	Integer	4	Bit 0 = CobraNet Port is Linked Bit 1 = CobraNet Port is Full Duplex Bit 2 = CobraNet Port is Receiving Packets (Null to query in text)	-

CNETLOC – CobraNet Board Location

This command sets/reports the assigned location of the CONNECT CobraNet Bridge board.

Command Form: *DEVICE* **CNETLOC** [Value]

Argument	Type	Size	Values	Units
Value	String	54	1 - 54 Characters (Null to query in text)	-

CNETMAC – CobraNet Board MAC Address

This command reports the MAC Address of the CONNECT CobraNet Bridge board. **This command is Query ONLY.**

Command Form: *DEVICE* **CNETMAC** [Value]

Argument	Type	Size	Values	Units
Value	String	20	“xx:xx:xx:xx:xx:xx” NULL terminated MAC address	-

CNETNAME – CobraNet Board Name

This command sets/reports the assigned name of the CONNECT CobraNet Bridge board.

Command Form: *DEVICE* **CNETNAME** [Value]

Argument	Type	Size	Values	Units
Value	String	54	1 - 54 Characters (Null to query in text)	-

CNETRXBNUM – CobraNet Rx Bundle Number

This command sets/reports the CobraNet Rx Bundle Number. Set to lowest value if bundle type is selected.

Command Form: *DEVICE* **CNETRXBNUM** <Receiver> [Value]

Argument	Type	Size	Values	Units
Receiver	Integer	4	1 – 4 Cobra Net Receiver Number	-
Value	Integer	4	0 = Default 1 – 255 if Multicast 256 – 65535 if Unicast (Null to query in text)	-

CNETRXSTATUS – CobraNet Rx Bundle Status

This command reports the CobraNet Rx Bundle Status (audio presence) for all 8 channels. **This command is Query ONLY and may be sent asynchronously.**

Command Form: *DEVICE* **CNETRXSTATUS** <Receiver> [Value]

Argument	Type	Size	Values	Units
Receiver	Integer	4	1 – 4 Cobra Net Transmitter Number	-
Value	Bit Map Rx Status	4	XXXX XXXX Channel 1 Channel 2 Channel 3 Channel 4 Channel 5 Channel 6 Channel 7 Channel 8 For each bit: 0 = No Signal 1 = Signal (Null to query in text)	Value

CNETTXBNUM – CobraNet Tx Bundle Number

This command sets/reports the CobraNet Tx Bundle Number. Set to lowest value if bundle type is selected.

Command Form: *DEVICE* **CNETTXBNUM** <Transmitter> [Value]

Argument	Type	Size	Values	Units
Transmitter	Integer	4	1 – 4 Cobra Net Transmitter Number	-
Value	Integer	4	0 = Default 1 – 255 if Multicast 256 – 65535 if Unicast (Null to query in text)	-

CNETTXDEPTH – CobraNet Tx Bundle Bit Depth

This command sets/reports the CobraNet Tx Bundle Bit Depth.

Command Form: *DEVICE* **CNETTXDEPTH** <Transmitter> [Depth]

Argument	Type	Size	Values	Units
Transmitter	Integer	4	1 – 4 Cobra Net Transmitter Number	-
Depth	Integer	4	16, 20, or 24 ONLY (Default = 24) (Null to query in text)	-

CNETTXLATENCY – CobraNet Tx Bundle Maximum Unicast

This command sets/reports the CobraNet Tx Bundle Maximum Unicast.

Command Form: *DEVICE* **CNETTXLATENCY** <Transmitter> [Value]

Argument	Type	Size	Values	Units
Transmitter	Integer	4	1 – 4 Cobra Net Transmitter Number	-
Value	Integer	4	0 = 5.33 ms (Default) 1 = 2.66 ms 2 = 1.33 ms (Null to query in text)	-

CNETTXMAXUNI – CobraNet Tx Bundle Latency

This command sets/reports the CobraNet Tx Maximum Unicast.

Command Form: *DEVICE* **CNETTXMAXUNI** <Transmitter> [Value]

Argument	Type	Size	Values	Units
Transmitter	Integer	4	1 – 4 Cobra Net Transmitter Number	-
Value	Integer	4	1, 2, 3, or 4 ONLY (Default = 1) (Null to query in text)	-

CNETTXSTATUS – CobraNet Tx Bundle Status

This command reports the CobraNet Tx Bundle Status (audio presence). **This command is Query ONLY and may be sent asynchronously.**

Command Form: *DEVICE* **CNETTXSTATUS** <Transmitter> [Value]

Argument	Type	Size	Values	Units
Transmitter	Integer	4	1 – 4 Cobra Net Transmitter Number	-
Value	Tx Status	4	0 = No Signal on Bundle 1 = Signal on Bundle (Null to query in text)	Value

CNETVER – CobraNet Tx Board F/W Version

This command reports the firmware version of the CobraNet board. **This command is Query ONLY.**

Command Form: *DEVICE* **CNETVER** [Value]

Argument	Type	Size	Values	Units
CNetVersion	String	12	Version format “MM.mm.rr.ee” (NULL terminated – Major.Minor.Revision.Engineering)	-

COMPDLY – Compressor Delay

This command sets signal compression delay on a Channel for look ahead compression functionality. Delay from 0-20 msec.

Command Form: **DEVICE COMPDLY** <Channel> <Group> [Value]

Argument	Type	Size	Values	Units
Channel	Channel	1	See Groups and Channels	-
Group	Group	1	23 (J)	-
Value	Unsigned Integer	2	0 - 20 (Null to query in text)	msec

COMPDLYEN – Compressor Delay Enable

This command enables signal compression delay on a Channel for look-ahead compression functionality

Command Form: **DEVICE COMPDLYEN** <Channel> <Group> [Value]

Argument	Type	Size	Values	Units
Channel	Channel	1	See Groups and Channels	-
Group	Group	1	23 (J)	-
Value	Unsigned Short	2	0 = Off 1 = On 2 = Toggle (Null to query in text)	-

COMPERSIST – CobraNet Persistence

This command sets/reports the CobraNet Persistence for the CONNECT CobraNet board.

Command Form: **DEVICE COMPERSIST** [Value]

Argument	Type	Size	Values	Units
Value	Integer	4	0 - 255 (Default = 32) (Null to query in text)	-

COMPRESS – Compressor Adjust

This command selects/reports the settings of the compressor.

Command Form: **DEVICE COMPRESS** <Channel> [Threshold Ratio Attack Release Gain]

Argument	Type	Size	Values	Units
Channel	Channel	1	See Groups and Channels	-
Group	Group	1	5 (P)	-
Threshold	Signed Integer	1	-60 – 20 (Null to query in text)	dB
Ratio	Unsigned Integer	1	1 – 20	
Attack	Unsigned Float	2	0.00 – 100.00	Ms
Release	Unsigned Integer	2	100 – 2000	Ms
Gain	Unsigned Float	4	0.00 – 20.00	dB

COMPSEL – Compression Select

This command selects/reports the compressor activation.

Command Form: **DEVICE COMPSEL** <Channel> [Value]

Argument	Type	Size	Values	Units
Channel	Channel	1	See Groups and Channels	-
Group	Group	1	5 (P)	-
Value	Unsigned Integer	2	0 = Off 1 = On 2 = Toggle (Null to query in text)	-

COUNTRY – Country Selection

This command sets / reports the country for telco compliance purposes.

Command Form: *DEVICE COUNTRY* [Value]

Argument	Type	Size	Values	Units
Value	Unsigned Integer	4	1 = US / Canada 2 = Europe 3 = Mexico 4 = Australia 5 = South Africa 6 = Japan 7 = Brazil 8 = South Korea 9 = China 10 = Singapore 11 = Taiwan 12 = New Zealand 13 = India 14 = Hong Kong 15 = Malaysia 16 = Argentina (Null to query in text)	-

CTRLMASTER – Control Master Mode

This command reports the mode of the unit for SNMP control.

Command Form: *DEVICE CTRLMASTER* [Value]

Argument	Type	Size	Values	Units
Value	Unsigned Integer	4	1 = Master 2 = Slave (Null to query in text)	-

DECAY – Decay Adjust

This command selects/reports the setting of the decay rate.

Command Form: *DEVICE DECAY* <Channel> [Value]

Argument	Type	Size	Values	Units
Channel	Channel	1	See Groups and Channels	-
Group	Group	1	3 (M)	-
Value	Unsigned Integer	2	1 = Slow 2 = Medium 3 = Fast (Null to query in text)	-

DANTEADDR – Dante Board IP Addresses

This command selects/reports the IP addresses of the Ethernet ports on the Dante board. **This command is Query ONLY.**

Command Form: *DEVICE DANTEADDR* [Primary Port IP Address] [Redundant Port IP Address]

Argument	Type	Size	Values	Units
Primary Port IP Address	IP Address	4	(Null to query in text)	-
Redundant Port IP Address	IP Address	4	(Null to query in text)	-

DANTEAPPVER – Dante Internal Application Version

This command reports the Internal Application version of the Dante unit's Controller. **This command is Query ONLY.**

Command Form: *DEVICE DANTEAPPVER* [Value]

Argument	Type	Size	Values	Units
Dante Version	String	16	Null terminated version string	-

DANTEBFVER – Dante BlackFin F/W Version

This command reports the firmware version of the Dante unit's BlackFin. **This command is Query ONLY.**

Command Form: *DEVICE DANTEBFVER* [Value]

Argument	Type	Size	Values	Units
BlackFin Version	String	16	Null terminated version string	-

DANTEBRIDGE – Ethernet IP, Listen and Destination Ports for Dante Events

This command selects/reports the IP address, Listen and Destination Ports of the DANTE packets.

Command Form: *DEVICE DANTEBRIDGE* [Listen Port] [Destination IP] [Destination Port]

Argument	Type	Size	Values	Units
Listen Port	Ethernet Port	4	Listen (Connect Dante) port (Null to query in text)	-
Destination IP	IP Address	4	Usually a multicast address	-
Destination Port	Ethernet Port	4	Destination port	-

DANTECAPVER – Dante Compatibility Version

This command reports the Compatibility File version of the Dante unit's Controller. **This command is Query ONLY.**

Command Form: *DEVICE DANTECAPVER* [Value]

Argument	Type	Size	Values	Units
Dante Version	String	16	Null terminated version string	-

DANTEVBRD – Name of the Dante Board to Send Events To

This command sets or reports the name of the Dante Board that all subsequent Event commands will be sent to. This should be the name of a Dante Board inside the Dante device.

Command Form: *DEVICE DANTEVBRD* [Value]

Argument	Type	Size	Values	Units
Value	String	32	1-31 = Characters Last character always NULL (Null to query in text)	-

DANTEEVENT – Dante Event (To Dante device)

This command sends an Event to a Dante-Connected system. **There is no Query for this command.**

Command Form: *DEVICE DANTEEVENT* [Value]

Argument	Type	Size	Values	Units
Value	Event	4	Event Number	-

DANTEINCHAN – Dante Input Channel Name

This command reports the Dante Input Channel Name for the given Channel Number (1-8). **This command is Query ONLY.**

Command Form: DEVICE DANTEINCHAN <Channel> <Name>

Argument	Type	Size	Values	Units
Channel	Integer	4	1-8 Only	-
Name	Group	32	1 – 31 Characters Last character always NULL (Null to query in text)	-

DANTELINK – Dante LINK and DUPLEX Status

This command reports the Dante LINK and DUPLEX status of the Primary and Secondary LAN connection. **This command is Query ONLY.**

Command Form: DEVICE DANTELINK <Primary Speed>< Primary Link>< Primary Duplex>
<Secondary speed><Secondary Link><Secondary Duplex>

Argument	Type	Size	Values	Units
Primary Speed	Short	2	0 – Not Connected 10 – 10 Mbit/Sec 100 – 100 Mbit/Sec 1000 – 1 Gigbit/Sec (Null to query in text)	-
Primary Link	Char	1	0 – Not Currently Linked 1 – Currently Linked	-
Primary Duplex	Char	1	0 – Simplex mode 1 – Duplex mode	-
Secondary Speed	Short	2	0 – Not Connected 10 – 10 Mbit/Sec 100 – 100 Mbit/Sec 1000 – 1 Gigbit/Sec	-
Secondary Link	Char	1	0 – Not Currently Linked 1 – Currently Linked	-
Secondary Duplex	Char	1	0 – Simplex mode 1 – Duplex mode	-

DANTEMAC – Dante Board MAC Addresses

This command reports the MAC Addresses of the Dante board. **This command is Query ONLY.**

Command Form: DEVICE DANTEMAC [Primary Port MAC Address][Redundant Port MAC Address]

Argument	Type	Size	Values	Units
Primary Port MAC Address	String	20	“xx:xx:xx:xx:xx:xx” NULL terminated MAC address (Null to query in text)	-
Redundant Port MAC Address	String	20	“xx:xx:xx:xx:xx:xx” NULL terminated MAC address (Null to query in text)	-

DANTEMVER – Dante Mondo File Version

This command reports the firmware version of the Dante unit's Mondo File. **This command is Query ONLY.**

Command Form: DEVICE DANTEMVER

Argument	Type	Size	Values	Units
Mondo Version	String	16	NULL terminated version string	-

DANTENAME – Dante Board Name

This command reports the assigned Dante Board Name. **This command is Query ONLY.**

Command Form: *DEVICE* **DANTENAME** [Value]

Argument	Type	Size	Values	Units
Value	String	32	1 – 31 Characters Last character always NULL (Null to query in text)	-

DANTEOUTCHAN – Dante Output Channel Name

This command reports the Dante Output Channel Name for the given Channel Number (1-8). **This command is Query ONLY.**

Command Form: *DEVICE* **DANTEOUTCHAN** <Channel> <Name>

Argument	Type	Size	Values	Units
Channel	Integer	4	1 - 8 Only	-
Name	String	32	1 – 31 Characters Last character always NULL (Null to query in text)	-

DANTERESET – Dante Reset

Resets the Dante connection and processor (not the BlackFin). **There is no query for this command.**

Command Form: *DEVICE* **DANTERESET**

Argument	Type	Size	Values	Units
-	-	-	-	-

DANTEUPDATE – Update Dante Parameters

Updates the Dante parameters set from the Dante Software program since the last reset, to last DANTEUPDATE, or the last PUTGET request. **There is no query for this command.**

Command Form: *DEVICE* **DANTEUPDATE**

Argument	Type	Size	Values	Units
-	-	-	-	-

DANTEVER – Dante F/W Version

This command reports the Dante firmware version. **This command is Query ONLY.**

Command Form: *DEVICE* **DANTEVER** [Value]

Argument	Type	Size	Values	Units
Dante Version	String	16	NULL terminated version string	-

DEFAULT – Default The Unit

Sets the unit to factory defaults. **There is no query for this command.**

Command Form: *DEVICE* **DEFAULT**

No Arguments

DELAY – Delay Adjust

This command selects/reports the setting of delay time.

Command Form: *DEVICE* **DELAY** <Channel> [Value]

Argument	Type	Size	Values	Units
Channel	Channel	1	See Groups and Channels	-
Group	Group	1	5 (P)	-
Value	Unsigned Float	2	0.00 – 250.00 (Null to query in text)	Ms

DELAYSEL – Delay Select

This command selects/reports the delay activation of an assignable processing channel.

Command Form: **DEVICE DELAYSEL** <Channel> [Value]

Argument	Type	Size	Values	Units
Channel	Channel	1	See Groups and Channels	-
Group	Group	1	5 (P)	-
Value	Unsigned Integer	2	0 = Off 1 = On 2 = Toggle (Null to query in text)	-

DEVICENAME – Argument Identification Label

This selects/reports the Device Argument identification label of the specific channel.

COMMAND FORM: **DEVICE DEVICENAME** <Channel> <Group> [Value]

Argument	Type	Size	Values	Units
Channel	Channel	1	See Groups and Channels	-
Group	Group	1	1, 2, 3, 7 (I, O, M, L)	-
Reserved	Unsigned Integer	2	0	-
Label	String	12	1 – 12 characters CLEAR = clear the label (Null to query in text)	-

DEVICESUBTYPE – Sets the Subtype of a Connected Device

This command enables/disables or reports the current type of device connected to an input or output.

Command Form: **DEVICE DEVICESUBTYPE** <Channel> <Group> [Value]

Argument	Type	Size	Values	Units
Channel	Channel	1	See Groups and Channels	-
Group	Group	1	1, 2, 3, 7 (I, O, M, L)	-
Value	Unsigned Integer	2	(NULL to query in text)	-

DEVICETYPE – Sets the Type of a Connected Device

This command enables / disables or reports the current type of device connected to an input or output.

Command Form: **DEVICE DEVICETYPE** <Channel> <Group> [Value]

Argument	Type	Size	Values	Units
Channel	Channel	1	See Groups and Channels	-
Group	Group	1	1, 2, 3, 7 (I, O, M, L)	-
Value	Unsigned Integer	2	(NULL to query in text)	-

DFLTM – Default Meter

This command selects/reports the setting of the default meter on the front panel.

Command Form: **DEVICE DFLTM** [Channel Group Position]

Argument	Type	Size	Values	Units
Channel	Channel	1	See Groups and Channels (Null to query in text)	-
Group	Group	1	1, 2, 3, 7, 16, 17 (I, O, M, L, T, R)	-
Position	Meter Type	2	1 – 4, as applicable for group See Meter Type Definitions	-

DIAG – Diagnostic Commands

This command is used to return status and diagnostic information. It is intended to be used as a text command only. **This is a query only command.**

Command Form: DEVICE **DIAG** <Channel> <Group> [Value]

Argument	Type	Size	Values	Units
Channel	Channel	1	See Groups and Channels	-
Group	Group	1	23 (J)	-
Value	Unsigned Short	2	0 = List of current commands (J) Power Amp 1 = Fan/Temp 2 = Noise Gate 3 = Feedback Nodes	-
Information	String	80	Diagnostic String (ALWAYS NULL IN TEXT)	-

DIAL – DTMF Dialing

This command dials a DTMF sequence or reports back the last sequence dialed.

Command Form: DEVICE **DIAL** <Channel> [Number]

Argument	Type	Size	Values	Units
Channel	Channel	1	See Groups and Channels	-
Group	Group	1	17 (R)	-
Reserved		2	0	-
Number	String	40	1 – 40 Chars of '0' – '9', '*', '#', ',' (Null to query last number dialed in text)	-

DID – Device ID

This command reports the device id. **This command is read only except through the front panel.**

Command Form: DEVICE **DID** [Value]

Argument	Type	Size	Values	Units
Value	Unsigned Integer	4	See Type And Device IDs (Null sent in text, Value returned)	-

DIDCONFLICT – Dante F/W Version

This command reports a DID conflict has occurred on a Glink Lite Device (BF Mic, CobraNet Bridge, Dante, etc.). **This command cannot be queried – notification only.**

Command Form: DEVICE **DIDCONFLICT**

Argument	Type	Size	Values	Units
-	-	-	-	-

DIGMICS – Number of Digital Mics on a CONVERGE Pro Board

This command selects/reports the number of digital microphone inputs that will be processed in the microphone processing chain (AEC, Noise Suppression, etc). The DIGMICSSEN system wide command must also be enabled. A CONNECT unit (i.e. CobraNet or Dante) must be connected to the LINK IN port of the Converge Pro unit. When enabled the associated analog input channel is disabled and the associated analog output channel is mirrored to the digital output. See the table below:

Digital Channels	880 Input/Output	840T Input/Output
0	-	-
2	7-8	3-4
4	5-8	1-4
8	1-8	n/a

Command Form: *DEVICE DIGMICS* [Number of Mics]

Argument	Type	Size	Values	Units
Number of Mics	Unsigned Integer	4	0,2, 4, 8 – Number of digital mics on a board (only allowed values) DEFAULT = 0 (Null to query in text)	-

DIGMICSSEN – Enable/Disable Digital Mics

This command selects/reports the system wide option for Digital Microphone Input Processing. When enabled, Expansion Buses S-Z are no longer available in the matrix. The DIGMICS command must also be enabled on each CONVERGE Pro that is doing digital microphone processing.

Command Form: *DEVICE DIGMICSSEN* [ENABLE]

Argument	Type	Size	Values	Units
Enable	Unsigned Integer	4	0 = Off 1 = On 2 = Toggle (Null to query in text)	-

DTMFLVL – DTMF Tone Level

This command selects/reports the DTMF tone level.

Command Form: *DEVICE DTMFLVL* <Channel> [Value]

Argument	Type	Size	Values	Units
Channel	Channel	1	See Groups and Channels	-
Group	Group	1	17 (R)	-
Value	Signed Float	2	-12.00 – 12.00 (Null to query in text)	dB

DTONELVL – Dial Tone Level

This command selects/reports the audible dial tone level.

Command Form: *DEVICE DTONELVL* <Channel> [Value]

Argument	Type	Size	Values	Units
Channel	Channel	1	See Groups and Channels	-
Group	Group	1	17 (R)	-
Value	Signed Float	2	-12.00 – 12.00 (Null to query in text)	dB

DUPDATE – Download Update

This command reports the status of download updates.

Command Form: **DEVICE DUPDATE** [Channel Group Status Percent Done Message]

Argument	Type	Size	Values	Units
Channel	Unsigned Integer	1		-
Group	Unsigned Integer	1		-
Status	Unsigned Integer	1	(Null to query in text)	-
Percent Done	Unsigned Integer	1		-
Message	Char	60		-

DVER – Command Dictionary Version

This command reports the version of the command dictionary being used by the unit. **This command is read only.**

Command Form: **DEVICE DVER** [Value]

Argument	Type	Size	Values	Units
Value	Unsigned Integer	4	(Sent with a Null in text)	-

ENETADDR – Ethernet Port IP Address

This command selects/reports the IP address of the Ethernet port on the unit.

Command Form: **DEVICE ENETADDR** [Value]

Argument	Type	Size	Values	Units
Value	IP Address	4	(Null to query in text)	-

ENETDHCP – Ethernet DHCP Selection

This command selects/reports the use of DHCP of the Ethernet port on the unit.

Command Form: **DEVICE ENETDHCP** [Value]

Argument	Type	Size	Values	Units
Value	Unsigned Integer	4	0 = Off 1 = On 2 = Toggle (Null to query in text)	-

ENETDNS – Ethernet DNS Selection

This command selects/reports the use of DNS of the Ethernet port on the unit.

Command Form: **DEVICE ENETDNS** [Value]

Argument	Type	Size	Values	Units
Value	Unsigned Integer	4	0 = Off 1 = On 2 = Toggle (Null to query in text)	-

ENETDNSA – Ethernet DNS Server Address

This command selects/reports the DNS server IP address of the Ethernet port on the unit.

Command Form: **DEVICE ENETDNSA** [Value]

Argument	Type	Size	Values	Units
Value	IP Address	4	(Null to query in text)	-

ENETDNSA2 – Ethernet DNS Server Address 2

This command selects/reports the alternate DNS server IP address of the Ethernet port on the unit.

Command Form: *DEVICE ENETDNSA2* [Value]

Argument	Type	Size	Values	Units
Value	IP Address	4	(Null to query in text)	-

ENETDOMAIN – Ethernet Domain Argument

This command selects/reports the Domain Argument of the Ethernet port on the unit.

Command Form: *DEVICE ENETDOMAIN* [Value]

Argument	Type	Size	Values	Units
Value	String	64	(Null to query in text)	-

ENETGATE – Ethernet Default Gateway Address

This command selects/reports the default gateway of the Ethernet port on the unit.

Command Form: *DEVICE ENETGATE* [Value]

Argument	Type	Size	Values	Units
Value	IP Address	4	(Null to query in text)	-

ENETSUBN – Ethernet Subnet Mask

This command selects/reports the Subnet mask of the Ethernet port on the unit.

Command Form: *DEVICE ENETSUBN* [Value]

Argument	Type	Size	Values	Units
Value	IP Address	4	(Null to query in text)	-

ENETVLAN – Enable VLAN Tagging

This command enables/disables VLAN tagging. **Valid on VH20 ONLY.** Change requires reboot to become effective.

Command Form: *DEVICE ENETVLAN* [Value]

Argument	Type	Size	Values	Units
Value	Unsigned Integer	4	0 = VLAN Tagging Off 1 = VLAN Tagging On 2 = Toggle (Null to query in text)	-

ENETVLANID – VLAN ID

This command set/reports VLAN Tag ID for all Ethernet packets (including SIP). **Valid on VH20 ONLY.** Change requires reboot to become effective.

Command Form: *DEVICE ENETVLANID* [Value]

Argument	Type	Size	Values	Units
Value	Unsigned Integer	4	1 – 4094 (Null to query in text)	-

ENETVLANPRI – VLAN Priority

This command sets/reports the VLAN Tagging Priority for all IP packets. **Valid on VH20 ONLY.** Change requires reboot to become effective.

Command Form: *DEVICE ENETVLANPRI* [Value]

Argument	Type	Size	Values	Units
Value	Unsigned Integer	4	0 – 7 (Null to query in text)	-

EREF – Expansion Bus Reference

This command selects an output or reports which output is the expansion bus reference.

Command Form: **DEVICE EREF** <Channel> [Value Channel Value Group]

Argument	Type	Size	Values	Units
Channel	Channel	1	See Reference Channels in Groups and Channels	-
Group	Group	1	8 (A, E)	-
Value	Channel	1	0 = none See 2, 20 (O, B) in Groups and Channels (Null to query in text)	-
Value	Group	1	0 for none or 2, 20 (N for none or O, B)	-

EVENT – Run Scheduled Event

This command manually runs a scheduled event on a unit. **There is no query associated with this command.**

Command Form: **DEVICE EVENT** <Channel> <Group>

Argument	Type	Size	Values	Units
Channel	Channel	1	1 - 10	-
Group	Group	1	21 (Q)	-
Reserved	Unsigned Short	2	0	-

FE – Feedback Elimination Enable

This command enables or disables feedback elimination on the power amplifier channel.

Command Form: **DEVICE FE** <Channel> <Group> [Value]

Argument	Type	Size	Values	Units
Channel	Channel	1	See GroupAndChannels	-
Group	Group	1	23 (J)	-
Value	Unsigned Short	2	0 = On 1 = Off 2 = Toggle (Null to query in text)	-

FEB – Feedback Elimination Bandwidth

This command sets the filter bandwidth of the notch filter. Options are a Q = 5 or Q = 10

Command Form: **DEVICE FEB** <Channel> <Group> [Value]

Argument	Type	Size	Values	Units
Channel	Channel	1	See GroupAndChannels	-
Group	Group	1	23 (J)	-
Value	Unsigned Short	2	0 = 5 1 = 10 Default 0 (5) (Null to query in text)	-

FEDR – Feedback Elimination Dynamic Node Reset

This command will reset only the dynamic filters on the feedback eliminator. There is no query associated with this command.

Command Form: **DEVICE FEDR** <CHANNEL> <GROUP>

Argument	Type	Size	Values	Units
Channel	Channel	1	See GroupAndChannels	-
Group	Group	1	23 (J)	-
Reserved	Zero	2	Value:0-16 (Null to query in text)	Nodes

FEF – Feedback Elimination Fixed Filter

This command sets the number of fixed filter to use in the feedback eliminator. The fixed filters number will be used during the initialization phase when gain is increased until feedback occurs. A fixed filter will be set at the feedback point during the initialization.

Command Form: DEVICE **FEF** <CHANNEL> <GROUP> [VALUE]

Argument	Type	Size	Values	Units
Channel	Channel	1	See GroupAndChannels	-
Group	Group	1	23 (J)	-
Reserved	Unsigned Short	2	Zero	-

FEG – Feedback Elimination Auto Gain Max

This command sets the target gain for auto setup in feedback cancellation.

Command Form: DEVICE **FEG** <Channel> <Group> [Value]

Argument	Type	Size	Values	Units
Channel	Channel	1	See GroupAndChannels	-
Group	Group	1	23 (J)	-
Reserved	Unsigned Short	2	0 - 8 (Null to query in text)	dB

FEGL – Feedback Elimination Gain Level

This command reports the gain value achieved at the end of the feedback automatic setup. The maximum value possible is set in the FEG command. **This is a query only command.**

Command Form: DEVICE **FEGL** <Channel> <Group> [Value]

Argument	Type	Size	Values	Units
Channel	Channel	1	See GroupAndChannels	-
Group	Group	1	23 (J)	-
Value	Signed Float	2	-99.99 to 99.99 (Sent with Null, value returned)	dB

FELD – Feedback Elimination Lock Depth

This command sets the operation of a fixed filter node to be either locked or unlocked. In locked mode, the fixed filter's depth will remain the same after all the fixed filters are placed. In unlocked mode, the fixed filter's depth can be modified anytime until the maximum depth is achieved.

Command Form: DEVICE **FELD** <Channel> <Group> [Value]

Argument	Type	Size	Values	Units
Channel	Channel	1	See GroupAndChannels	-
Group	Group	1	23 (J)	-
Value	Unsigned Float	2	0 = Locked 1 = Unlocked Default 0 (Null to query in text)	-

FEM – Feedback Elimination Mode

This command set the feedback mode to either Music or Voice. This effects how aggressive the reduction is.

Command Form: DEVICE **FEM** <Channel> <Group> [Value]

Argument	Type	Size	Values	Units
Channel	Channel	1	See GroupAndChannels	-
Group	Group	1	23 (J)	-
Value	Unsigned Float	2	0 = Locked 1 = Unlocked Default 0 (Null to query in text)	-

FEN – Feedback Elimination Nodes

This command reports the total number of filter nodes (fixed and dynamic) currently being used for the feedback cancellation. **This is a query only command.**

Command Form: DEVICE FEN <Channel> <Group> [Value]

Argument	Type	Size	Values	Units
Channel	Channel	1	See GroupAndChannels	-
Group	Group	1	23 (J)	-
Value	Unsigned Short	2	Total Nodes (ALWAYS NULL IN TEXT)	-

FER – Feedback Elimination Node Reset

This command resets both the fixed and dynamic filters on the feedback eliminator. **There is no query associated with this command.**

Command Form: DEVICE FER <Channel> <Group> [Value]

Argument	Type	Size	Values	Units
Channel	Channel	1	See GroupAndChannels	-
Group	Group	1	23 (J)	-
Value	Unsigned Short	2	Zero	-

FERNG – Feedback Elimination Ring Elimination Mode

This command enables/disables the Ring Elimination Mode on the feedback eliminator.

Command Form: DEVICE FERNG <Channel> <Group> [Value]

Argument	Type	Size	Values	Units
Channel	Channel	1	See GroupAndChannels	-
Group	Group	1	23 (J)	-
Reserved	Zero	2	0 = Off 1 = On 2 = Toggle (Null to query in text)	-

FES – Feedback Elimination Setup

This command reset the feedback eliminator and initiates an automatic training cycle. When the automatic setup is complete, the FESC (Feedback Elimination Setup Complete) command will be issued. **There is no query associated with this command.**

Command Form: DEVICE FES <Channel> <Group> [Value]

Argument	Type	Size	Values	Units
Channel	Channel	1	See GroupAndChannels	-
Group	Group	1	23 (J)	-
Reserved	Zero	2	Zero	-

FESC – Feedback Elimination Setup Complete

This command reports when the automatic feedback eliminator setup training cycle is in progress. The training cycle is started using the command FES (Feedback Elimination Setup). **This is a query only command.**

Command Form: DEVICE FESC <Channel> <Group> [Value]

Argument	Type	Size	Values	Units
Channel	Channel	1	See GroupAndChannels	-
Group	Group	1	23 (J)	-
Value	Unsigned Short	2	0 = Setup Complete 1 = Setup in Progress (Sent Null, Value Returned)	-

FILTER – Filter Adjust

This command selects/reports the settings of a filter.

Command Form: **DEVICE FILTER** <Channel> <Group> <Node> [Type Frequency Gain/Slope Bandwidth/Subtype]

Argument	Type	Size	Values	Units	
Channel	Channel	1	See Groups and Channels	-	
Group	Group	1	3, 5, 23, 29 (M, P, J, V)	-	
Node	Unsigned Integer	1	Group 3, 23, 29 Group 5	1 – 4 1 – 15	
Type	Unsigned Integer	1	0 = None 1 = All Pass 2 = Low Pass 3 = High Pass 4 = Low Shelving 5 = High Shelving 6 = Parametric Equalizer 7 = CD Horn 8 = Bessel Crossover 9 = Butterworth Crossover 10 = Linkwitz-Riley Crossover 11 = Notch (Null to query in text)	-	
Frequency	Unsigned Float	4	Type 0 Type 1 – 6, 8 – 11 Type 7	0 (Null in text) 20.00 – 20000.00 500.00 – 5000.00	Hz
Gain/Slope	Signed Float	2	Type 0 – 3, 7, 11 Type 4 – 6 Type 8 – 9 Type 10	0 (Null in text) -15.00 – 15.00 12, 18, 24 12, 24	dB / dB per Octave
Bandwidth/Subtype	Unsigned Float	2	Type 0 – 5, 7 Type 6, 11 Type 8 – 10	0 (Null in text) 0.05 – 5.00 2 = Low Pass 3 = High Pass	Octaves / Type

FILTSEL – Filter Select

This command turns on and off the filters.

Command Form: **DEVICE FILTSEL** <Channel> <Group> <Node> [Value]

Argument	Type	Size	Values	Units
Channel	Channel	1	See Groups and Channels	-
Group	Group	1	3, 5, 23, 29 (M, P, J, V)	-
Node	Unsigned Integer	1	Group 3, 23, 29 Group 5	1 – 4 0xFF for all (* text) 1 – 15 0xFF for all (* text)
Value	Unsigned Integer	1	0 = Off 1 = On 2 = Toggle (Null to query in text)	-

FLOW – Flow Control

This command selects/reports the flow control of the serial port on the unit. Hardware flow control is implemented using DTR and DSR.

Command Form: *DEVICE FLOW* [Value]

Argument	Type	Size	Values	Units
Value	Unsigned Integer	4	0 = Off 1 = On 2 = Toggle (Null to query in text)	-

FMP – First Mic Priority Mode

This command selects/reports first Mic priority mode.

Command Form: *DEVICE FMP* <Channel> [Value]

Argument	Type	Size	Values	Units
Channel	Channel	1	See Groups and Channels	-
Group	Group	1	4 (G)	-
Value	Unsigned Integer	2	0 = Off 1 = On 2 = Toggle (Null to query in text)	-

GAIN – Gain Adjustment

This command changes or reports back the gain for a channel.

Command Form: *DEVICE GAIN* <Channel> <Group> [Value] [Absol/Rel]

Argument	Type	Size	Values	Units
Channel	Channel	1	See Groups and Channels	-
Group	Group	1	1, 2, 3, 5, 7, 12, 16, 17, 25, 26 (I, J, O, M, P, L, F, T, R, K, Z, D, U, V)	-
Value	Signed Float	2	-99.90 – 99.90 ** (Null to query in text)	dB
Absol / Rel		0	A = Absolute R = Relative Null = Relative	-

NOTE: Values indicate valid range for entry values only. Actual internal range of the gain stage is from -65 to 20. Absolute values will be limited to the internal gain range.

GATE – Gate Status

This command reports the gate status of Mics. **This command is read only.**

Command Form: *DEVICE GATE* [Value]

Argument	Type	Size	Values	Units
Value	Hexadecimal	4	Bits 0 – 7 represent gate status on Mics 1 – 8 (Null sent in text, Value returned)	-

GHOLD – Gate Hold Time Adjust

This command selects/reports the setting of hold time.

Command Form: *DEVICE GHOLD* <Channel> [Value]

Argument	Type	Size	Values	Units
Channel	Channel	1	See Groups and Channels	-
Group	Group	1	3 (M)	-
Value	Unsigned Float	2	0.10 – 8.00 (Null to query in text)	S

GMODE – Gating Mode

This command selects/reports the setting of gating mode.

Command Form: **DEVICE GMODE** <Channel> [Value]

Argument	Type	Size	Values	Units
Channel	Channel	1	See Groups and Channels	-
Group	Group	1	3 (M)	-
Value	Unsigned Integer	2	1 = Auto 2 = Manual On 3 = Manual Off (Null to query in text)	-

GOVER – Gating Override

This command selects/reports the setting of gating override.

Command Form: **DEVICE GOVER** <Channel> [Value]

Argument	Type	Size	Values	Units
Channel	Channel	1	See Groups and Channels	-
Group	Group	1	3 (M)	-
Value	Unsigned Integer	2	0 = Off 1 = On 2 = Toggle (Null to query in text)	-

GPIOSTATUS – General Purpose Status

This command sets the state of a General Purpose Status Pin.

Command Form: **DEVICE GPIOSTATUS** Pin Port [Value]

Argument	Type	Size	Values	Units
Pin	Unsigned Integer	1	1 – 24 (Only user definable status pins.	-
Port	Unsigned Integer	1	1 – 2	-
Value	Unsigned Integer	2	0 = High 1 = Low 2 = Toggle (NULL to query in text)	-

GRATIO – Gate Ratio Adjust

This command selects/reports the setting of the gate ratio.

Command Form: **DEVICE GRATIO** <Channel> [Value]

Argument	Type	Size	Values	Units
Channel	Channel	1	See Groups and Channels	-
Group	Group	1	3 (M)	-
Value	Unsigned Integer	2	0 – 50 (Null to query in text)	dB

GREPORT – Gate Report

This command selects/reports the mode of gate and audio presence status reporting.

Command Form: **DEVICE GREPORT** [Value]

Argument	Type	Size	Values	Units
Value	Unsigned Integer	4	0 = Off 1 = On 2 = Toggle (Null to query in text)	-

GRPSEL – Gating Group Select

This command selects/reports which Gating Group a microphone input is assigned.

Command Form: DEVICE **GRPSEL** <Channel> [Value]

Argument	Type	Size	Values	Units
Channel	Channel	1	See Groups and Channels	-
Group	Group	1	3 (M)	-
Value	Channel	2	See 4 (G) in Groups and Channels (Null to query in text)	-

HDAEC – Enables/Disables HD AEC mode

This command enables the HD AEC Mode of a Beamforming Microphone Array.

Command Form: DEVICE **HDAEC** <Channel> <Group> [Value]

Argument	Type	Size	Values	Units
Channel	Channel	1	See Groups and Channels	-
Group	Group	1	29 (V)	-
Value	Unsigned Short	2	0 = Off 1 = On 2 = Toggle (Null to Query in Text)	-

HDAECMODE – Set/Report HD AEC mode

This command sets the HD AEC Mode of a Beamforming Microphone Array as Mono or Stereo.

Command Form: DEVICE **HDAECMODE** <Channel>

Argument	Type	Size	Values	Units
Channel	Channel	1	See Groups and Channels	-
Group	Unsigned Short	1	29 (V)	-
Value	Unsigned Short	2	1 = Mono – One reference per Beamforming Mic 2 = Stereo – Two references per Beamforming Mic (Null to Query in Text)	-

HDDREFSEL1 – Reference Select for Mono Channel Acoustic Echo Cancellation Block

This command Sets/Reports Reference for Mono AEC Block.

Command Form: DEVICE **HDDREFSEL1** <Channel> <Group> [Ref. Group][Ref. Channel]

Argument	Type	Size	Values	Units
Channel	Channel	1	See Groups and Channels	-
Group	Group	1	29 (V)	-
Reference Group	Group	1	8 (A) (Null to query in text)	-
Reference Channel	Channel	1	See Groups and Channels	-

HDDREFSEL2 – Reference Select for Stereo Channel Acoustic Echo Cancellation Block

This command Sets/Reports Reference for Stereo AEC Block.

Command Form: DEVICE **HDDREFSEL2** <Channel> <Group> [Ref. Group][Ref. Channel]

Argument	Type	Size	Values	Units
Channel	Channel	1	See Groups and Channels	-
Group	Group	1	29 (V)	-
Reference Group	Group	1	8 (A) (Null to query in text)	-
Reference Channel	Channel	1	See Groups and Channels	-

HDNLP – Non Linear Processing Adjust

This command selects/reports the setting of the Non-linear processing for each microphone channel. This command can be used to replace the NLP command for the M group.

Command Form: **DEVICE HDNLP** <Channel> <Group> [Value]

Argument	Type	Size	Values	Units
Channel	Channel	1	See Groups and Channels	-
Group	Group	1	3, 29 (M, V)	-
Value		2	0 = Off 1 = Soft 2 = Medium 3 = Aggressive (Null to query in text)	-

HOOK – Hook Flash

This command sends a hook flash. **There is no query for this command.**

Command Form: **DEVICE HOOK** <Channel>

Argument	Type	Size	Values	Units
Channel	Channel	1	See Groups and Channels	-
Group	Group	1	17 (R)	-
Reserved		2	0	-

HOOKD – Hook Flash Duration

This command selects/reports the hook flash duration.

Command Form: **DEVICE HOOKD** <Channel> [Value]

Argument	Type	Size	Values	Units
Channel	Channel	1	See Groups and Channels	-
Group	Group	1	17 (R)	-
Value	Unsigned Integer	2	50 – 2000 (Multiples of 10 Ms only) (Null to query in text)	Ms

LABEL – Label

This selects/reports the label of the specific channel or the unit.

Command Form: **DEVICE LABEL** <Channel> <Group> [In/Out] [Value]

Argument	Type	Size	Values	Units
Channel	Channel	1	See Groups and Channels	-
Group	Group	1	1, 2, 3, 4, 5, 6, 7, 8, 12, 13, 14, 16, 17, 20, 25, 26 (H, I, J, O, M, G, P, E, L, A, F, S, C, T, R, B, K, Z, D, U, V)	-
Input / Output Matrix	Unsigned Integer	2	Groups all but 6 Groups 6	0 0 = output 1 = input
Label	String	20	1 – 20 characters CLEAR = clear the label (Null to query in text)	-

LCDCONTRAST – LCD Contrast

This command selects/reports the LCD Contrast Setting.

Command Form: **DEVICE LCDCONTRAST** [Value]

Argument	Type	Size	Values	Units
Value	Unsigned Integer	4	0 (lightest) – 63 (darkest) (Null to query in text)	-

LMO – Last Mic On Mode

This command selects/reports last Mic on mode.

Command Form: `DEVICE LMO <Channel> [Value]`

Argument	Type	Size	Values	Units
Channel	Channel	1	See Groups and Channels	-
Group	Group	1	4 (G)	-
Value	Unsigned Integer	2	0 = Off 1 - 8 = Mic 1 – 8 to be the last mic 0xFF (* in text) = Last Mic to stay on (Null to query in text)	-

LOCALNUM – Local Number

This command sets or reports back the current value of the local number.

Command Form: `DEVICE LOCALNUM <Channel> [Number]`

Argument	Type	Size	Values	Units
Channel	Channel	1	See Groups and Channels	-
Group	Group	1	17 (R)	-
Reserved		2	0	-
Number	String	16	1 – 16 Chars of '0' – '9', '*', '#', ',' (Null to query in text)	-

LOCBLDG – Location: Building

This command sets/reports the location of the unit: Building string.

Command Form: `DEVICE LOCBLDG [Value]`

Argument	Type	Size	Values	Units
Value	String	80	CLEAR = Clear current value 1 – 63 Characters (Null to query in text)	-

LOCCITY – Location: City

This command sets/reports the location of the unit: City string.

Command Form: `DEVICE LOCCITY [Value]`

Argument	Type	Size	Values	Units
Value	String	80	CLEAR = Clear current value 1 – 63 Characters (Null to query in text)	-

LOCCNTRY – Location: Country

This command sets/reports the location country of the unit.

Command Form: `DEVICE LOCCNTRY [Value]`

Argument	Type	Size	Values	Units
Value	String	80	CLEAR = Clear current value 1 – 63 Characters (Null to query in text)	-

LOCCOMP – Location: Company

This command sets/reports the location of the unit: Company string.

Command Form: `DEVICE LOCCOMP [Value]`

Argument	Type	Size	Values	Units
Value	String	80	CLEAR = Clear current value 1 – 63 Characters (Null to query in text)	-

LOCREGION – Location: Region

This command sets/reports the location of the unit: Region string.

Command Form: **DEVICE LOCREGION** [Value]

Argument	Type	Size	Values	Units
Value	String	80	CLEAR = Clear current value 1 – 63 Characters (Null to query in text)	-

LOCROOM – Location: Room

This command sets/reports the location of the unit: Room string.

Command Form: **DEVICE LOCROOM** [Value]

Argument	Type	Size	Values	Units
Value	String	80	CLEAR = Clear current value 1 – 63 Characters (Null to query in text)	-

LOCSITENAME – Location: Site Argument

This command sets/reports the location of the unit Site name.

Command Form: **DEVICE LOCSITENAME** [Value]

Argument	Type	Size	Values	Units
Value	String	80	CLEAR = Clear current value 1 – 64 Characters (Null to query in text)	-

LOCSTATE – Location: State

This command sets/reports the location of the unit: State/Prefecture string.

Command Form: **DEVICE LOCSTATE** [Value]

Argument	Type	Size	Values	Units
Value	String	80	CLEAR = Clear current value 1 – 63 Characters (Null to query in text)	-

LOGMASK – Device Log Mask

This command sets or reports the device event log mask.

Command Form: *DEVICE LOGMASK* [Value]

Argument	Type	Size	Values	Units
Value	Hexadecimal	4	XXXX XXXX XXXX XXXX XXXX XXXX XXXX XXXX > Reset > Errors > Password Access > Telco On/Off > Dial > Call Duration > System Checks > Firmware Download > (Reserved) > Default > (Reserved) > (Reserved) > Safety Mute > Macro Execution > Preset Execution > Audio Clipping -> Microphone Gains -> Processor Gains -> Fader Gains -> Telco Gains -> Power Amp. Gains -> Power Amp. Errors -> Caller ID -> SIP Message Log ----- -> (Reserved) (Null to query in text)	-

LVL – Level

This command reports the level of a channel. **This command is read only.**

Command Form: *DEVICE LVL* <Channel> <Group> <Position> [Value]

Argument	Type	Size	Values	Units
Channel	Channel	1	See Groups and Channels	-
Group	Group	1	1, 2, 3, 5, 7, 12, 16, 17, 20, 25, 26 (I, J, O, M, P, L, F, T, R, K, Z)	-
Position	Meter Type	2	See Meter Type Definitions	-
Value	Signed Float	4	-99.99 – 99.99 (Sent with Null in text, Value returned)	dB

LVLREPORT – Level Report

This command selects/reports the status of level reporting for the specified channel.

Command Form: *DEVICE LVLREPORT* <Channel> <Group> <Position> [Value]

Argument	Type	Size	Values	Units
Channel	Channel	1	See Groups and Channels	-
Group	Group	1	1, 2, 3, 5, 7, 12, 16, 17, K, Z (I, J, O, M, P, L, F, T, R, K, Z)	-
Position	Meter Type	2	See Meter Type Definitions	-
Value	Unsigned Integer	4	0 = Off (Delete from list being reported) 1 = On (Add to list being reported) 2 = Toggle (Null to query in text)	-

LVLREPORTEN – Level Report Enable

Enables level reporting for the unit.

Command Form: *DEVICE* **LVLREPORTEN** [Value]

Argument	Type	Size	Values	Units
Value	Unsigned Integer	4	0 = Turn off reporting but leave current list 1 = Turn on reporting 2 = Turn off reporting and clear the list (Null to query in text)	-

MACRO – Macro Execution/Reporting

This command executes a specified macro or reports the last macro executed.

Command Form: *DEVICE* **MACRO** [Value]

Argument	Type	Size	Values	Units
Value	Channel	4	See 14 (C) in Groups and Channels (Null to query last macro ran in text)	-

NOTE: The response will indicate successful execution of the macro, but it does not guarantee that each command in the macro was executed.

MANUFACTURER – Manufacturer Identification Label

This command selects/reports the model identification label of the specified channel.

Command Form: *DEVICE* **MANUFACTURER** <Channel> <Group> <Reserved> [Value]

Argument	Type	Size	Values	Units
Channel	Channel	1	See Groups and Channels	-
Group	Group	1	1, 2, 3, 7 (I, O, M, L, D)	-
Reserved	Unsigned Integer	2	0	-
Label	String	16	1-16 characters CLEAR = clear the label (Null to query in text)	dB

MAX – Maximum Gain Setting

This command changes or reports back the maximum gain setting for an input, output or assignable processing block.

Command Form: *DEVICE* **MAX** <Channel> <Group> [Value]

Argument	Type	Size	Values	Units
Channel	Channel	1	See Groups and Channels	-
Group	Group	1	1, 2, 3, 5, 7, 12, 16, 17, 25, 26 (I, O, M, P, L, F, T, R, K, Z, D, U, V)	-
Value	Signed Float	2	-65.00 – 20.00 (Null to query in text)	dB

MC – Multi-Channel Mode

This command groups audio controls for channels. Audio Controls include Gain, Ramp Gain, and Mute.

Command Form: *DEVICE MC* <Channel> <Group> [Value]

Argument	Type	Size	Values	Units
Channel	Channel	1	1 – n (Max number of channels in Multi-Channel Group divided by 2)	-
Group	Group	1	128 (No text group)	-
Multi-Channel Group	Group	2	Only 23 (J) accepted for now. See GroupAndChannels	dB
Bitmap	Hexadecimal Integer	4	<p>Up to maximum number of channels per group</p>	-

MCGAIN – Multi-Channel Gain

This command that groups adjusts/reports audio gain of the grouped channels.

Command Form: *DEVICE MCGAIN* <Channel> <Group> [Value] [Absol/Rel]

Argument	Type	Size	Values	Units
Channel	Channel	1	1 – n (Max number of channels in Multi-Channel Group divided by 2)	-
Group	Group	1	128 (No text group)	-
Multi-Channel Group	Unsigned Integer	2	Only 23 (J) accepted for now. See GroupAndChannels	-
Value	String	4	-99.90 – 99.90 (Null to query in text)	dB
Absol./Rel.		0	A = Absolute R = Relative Null = Relative	-

MCMINMAX – Multi-Channel Min and max Gain Setting

This command changes or reports back the minimum and maximum gain setting for a channel

Command Form: *DEVICE MCMINMAX* <Channel> <Group> [Value] [Min Max]

Argument	Type	Size	Values	Units
Channel	Channel	1	See GroupAndChannels	-
Group	Group	1	128 (No text group)	-
Multi-Channel Group	Group	2	Only 23 (J) accepted for now. See GroupAndChannels	-
Value	Signed Short	2	-65.00 – 20.00 (Null to query in text)	dB
Max	Signed Short	2	-65.00 – 20.00	dB

MCMUTE – Multi-Channel Min and Max Gain Setting

This command performs/reports audio mutes of the grouped channels.

Command Form: `DEVICE MCMUTE <Channel> <Group> [Value]`

Argument	Type	Size	Values	Units
Channel	Channel	1	1 – n (Max number of channels in Multi-Channel Group divided by 2)	-
Group	Group	1	128 (No text group)	-
Multi-Channel Group	Group	1	Only 23 (J) accepted for now. See GroupAndChannels	-
Value	Unsigned Char	1	0 = Off 1 = On 2 = Toggle (Null to query in text)	-

MCRAMP – Multi-Channel Ramp

This command performs audio gain ramps of the grouped channels. **There is no query associated with this command.**

Command Form: `DEVICE MCRAMP <Channel> <Multi-Channel Group> <Rate> <Target>`

Argument	Type	Size	Values	Units
Channel	Channel	1	1 – n (Max number of channels in Multi-Channel Group divided by 2)	-
Group	Group	1	128 (No text group)	-
Multi-Channel Group	Group	2	Only 23 (J) accepted for now. See GroupAndChannels	-
Rate	Signed Integer	2	-50 – 50 If value = 0, the ramp will stop. If value < 0, the gain will ramp down. If value > 0, the gain will ramp up.	dB / sec
Target	Signed Integer	2	-65 – 20 If NULL in text or 0x80 in binary, the ramp will use the channel's maximum and minimum for a target.	dB

MIN – Minimum Gain Setting

This command changes or reports back the minimum gain setting for a channel.

Command Form: `DEVICE MIN <Channel> <Group> [Value]`

Argument	Type	Size	Values	Units
Channel	Channel	1	See Groups and Channels	-
Group	Group	1	1, 2, 3, 5, 7, 12, 16, 17, 25, 26 (I, J, O, M, P, L, F, T, R, K, Z, D, U, V)	-
Value	Signed Float	2	-65.00 – 20.00 (Null to query in text)	dB

MINMAX – Minimum and Maximum Gain Setting

This command changes or reports back the minimum and maximum gain setting for a channel.

Command Form: *DEVICE MINMAX* <Channel> <Group> [Min Max]

Argument	Type	Size	Values	Units
Channel	Channel	1	See Groups and Channels	-
Group	Group	1	1, 2, 3, 5, 7, 12, 16, 17, 25, 26 (I, J, O, M, P, L, F, T, R, K, Z, D, U, V)	-
Min	Signed Float	2	-65.00 – 20.00 (Null to query in text)	dB
Max	Signed Float	4	-65.00 – 20.00	dB

MLINE – Mic / Line Coarse Gain Setting

This command selects/reports the setting of coarse gain.

Command Form: *DEVICE MLINE* <Channel> [Value]

Argument	Type	Size	Values	Units
Channel	Channel	1	See Groups and Channels	-
Group	Group	1	3 (M)	-
Value	Unsigned Integer	2	0 = 0 dB 7 = 7 dB 14 = 14 dB 21 = 21 dB 28 = 28 dB 35 = 35 dB 41 = 41 dB 50 = 50 dB 56 = 56 dB (Null to query in text) (No other values are valid and accepted)	-

MMAX – Maximum Number of Microphones

This command selects/reports the maximum number of microphones for a Gating Group.

Command Form: *DEVICE MMAX* <Channel> [Value]

Argument	Type	Size	Values	Units
Channel	Channel	1	See Groups and Channels	-
Group	Group	1	4 (G)	-
Value	Unsigned Integer	2	0 = Unlimited 1 - 8 = Maximum # of Mics (Null to query in text)	-

MODEL – Model Identification Label

This command selects/reports the model identification label of the specified channel.

Command Form: *DEVICE MODEL* <Channel> <Group> <Reserved> [Value]

Argument	Type	Size	Values	Units
Channel	Channel	1	See Groups and Channels	-
Group	Group	1	1, 2, 3, 7 (I, O, M, L, D)	-
Reserved	Unsigned Integer	2	0	-
Label	String	16	1-16 characters CLEAR = clear the label (Null to query in text)	dB

MTRX – Matrix Routing

This command selects/reports the matrix routing of an input to an output.

Command Form: **DEVICE MTRX** <Src. Ch.> <Src. Gp.> <Dest. Ch.> <Dest. Gp.> [Value]

Argument	Type	Size	Values	Units
Source Channel	Channel	1	See Groups and Channels	-
Source Group	Group	1	1, 3, 5, 6, 7, 12, 17, 25, 26 (I, M, P, E, L, F, R, K, Z, U, V)	-
Destination Channel	Channel	1	See Groups and Channels	-
Destination Group	Group	1	2, 5, 6, 12, 16, 20, 25, 26 (H, J, O, P, E, F, T, B, K, D)	-
Value	Unsigned Integer	4	0 = Cross point off 1 = Cross point on (Not Valid for Mic Sources) 2 = Toggle (Not Valid for Mic Sources) 3 = Non Gated (Mic Sources Only) 4 = Gated (Mic Sources Only) 5 = Pre-AEC (Mic Sources Only) 6 = Routing Prohibited (Cross point is off and may not be turned on) (Null to query in text)	-

MTRXCLEAR – Clear Matrix

Clears the ENTIRE matrix for the unit. **There is no query for this command.**

Command Form: **DEVICE MTRXCLEAR**

No Arguments

MTRXLVL – Matrix Attenuation Adjust

This command selects/reports the matrix level at the cross point.

Command Form:

DEVICE MTRXLVL <Src. Ch.> <Src. Gp.> <Dest. Ch.> <Dest. Gp.> [Value] [A/R]

Argument	Type	Size	Values	Units
Source Channel	Channel	1	See Groups and Channels	-
Source Group	Group	1	1, 3, 5, 6, 7, 12, 17, 25, 26 (I, M, P, E, L, F, R, K, Z, U, V)	-
Destination Channel	Channel	1	See Groups and Channels	-
Destination Group	Group	1	2, 5, 6, 12, 16, 25, 26 (H, J, O, P, E, F, T, K, D)	-
Value	Signed Float	4	-99.00 – 99.00 ** (Null to query in text)	dB
Absol / Rel		0	A = Absolute R = Relative Null = Relative	-

NOTE: Values indicate entry range only. Actual internal range of the matrix attenuation is from -60 to +12dB, and absolute values are limited to the internal gain range.

MTRXTYPE – Select Pre-AEC Gated or Non-Gated Routing

This command selects whether the Pre-AEC routing is Gated or Non-Gated.

Command Form: **DEVICE MTRXTYP** <Type>

Argument	Type	Size	Values	Units
Type	Integer	4	0 = Gated (Default) 1 = Non-Gated 2 = Toggle (Null to query in text)	-

MUTE – Mute

This command selects/reports the setting of mute on a channel.

Command Form: **DEVICE MUTE** <Channel> <Group> [Value]

Argument	Type	Size	Values	Units
Channel	Channel	1	See Groups and Channels	-
Group	Group	1	1, 2, 3, 5, 7, 12, 16, 17, 25, 26 (I, J, O, M, P, L, F, T, R, K, Z, D, U, V)	-
Value	Unsigned Integer	2	0 = Off 1 = On 2 = Toggle (Null to query in text)	-

NAME – Unit Name (NETBIOS Name)

This command sets/reports the name of the unit which is also used for its NETBIOS name.

Command Form: **DEVICE NAME** [Value]

Argument	Type	Size	Values	Units
Value	String	16	1 – 15 Characters (Null to query in text)	-

NCD – Noise Cancellation Depth Adjust

This command selects/reports the depth setting of the Noise Cancellation.

Command Form: **DEVICE NCD** <Channel> <Group> [Value]

Argument	Type	Size	Values	Units
Channel	Channel	1	See Groups and Channels	-
Group	Group	1	3, 17, 26 (M, R, Z, V)	-
Value	Unsigned Integer	2	6 – 15 (Null to query in text)	dB

NCSEL – Noise Cancellation Select

This command selects/reports the setting of the Noise Cancellation for each microphone channel.

Command Form: **DEVICE NCSEL** <Channel> <Group> [Value]

Argument	Type	Size	Values	Units
Channel	Channel	1	See Groups and Channels	-
Group	Group	1	3, 17, 26 (M, R, Z, V)	-
Value	Unsigned Integer	2	0 = Off 1 = On 2 = Toggle (Null to query in text)	-

NLP – Non Linear Processing Adjust

This command selects/reports the setting of non-linear processing for each microphone channel.

Command Form: **DEVICE NLP** <Channel> [Value]

Argument	Type	Size	Values	Units
Channel	Channel	1	See Groups and Channels	-
Group	Group	1	3 (M)	-
Value	Unsigned Integer	2	0 = Off 1 = Soft 2 = Medium 3 = Aggressive (Null to query in text)	-

NOM – Number of Open Microphones Mode

This command selects/reports the setting of Number of Open Microphones (NOM) on output channels.

Command Form: **DEVICE NOM** <Channel> <Group> [Value]

Argument	Type	Size	Values	Units
Channel	Channel	1	See Groups and Channels	-
Group	Group	1	2, 16, 25 (J, O, T, K, D)	-
Value	Unsigned Integer	2	0 = Off 1 = On 2 = Toggle (Null to query in text)	-

NTPSRV – NTP Network Time Server Address

This command selects/reports the IP addresses of the NTP Time Server the unit's NTP client requests time status from.

Command Form: **DEVICE NTPSRV** [Value 1 Value 2]

Argument	Type	Size	Values	Units
Value 1	IP Address	4	(Null to query in text)	-
Value 2	IP Address	4		-

NULL – Null the Telephone Line

This command nulls the telephone line. **There is no query for this command.**

Command Form: **DEVICE NULL** <Channel>

Argument	Type	Size	Values	Units
Channel	Channel	1	See Groups and Channels	-
Group	Group	1	17 (R)	-
Reserved		2	0	-

OFFA – Off Attenuation Mode

This command selects/reports the off attenuation value of a Mic channel.

Command Form: **DEVICE OFFA** <Channel> [Value]

Argument	Type	Size	Values	Units
Channel	Channel	1	See Groups and Channels	-
Group	Group	1	3 (M)	-
Value	Unsigned Float	2	0.00 – 60.00 (Null to query in text)	-

ORDER – Number of board to the Top and End of the Expansion Bus chain

This command is used to query the number of boards from the TOP and END of the Expansion Bus chain. **This command is QUERY ONLY.**

Command Form: **DEVICE ORDER** [From the TOP] [From the END]

Argument	Type	Size	Values	Units
From the TOP	Unsigned Short	2	Number of boards from the TOP of the Expansion Bus chain (Null to query in text)	-
From the END	Unsigned Short	2	Number of boards from the END of the Expansion Bus chain (Null to query in text)	-

PAA – PA Adaptive Mode

This command selects/reports PA adaptive mode for the specified Mic.

Command Form: **DEVICE PAA** <Channel> [Value]

Argument	Type	Size	Values	Units
Channel	Channel	1	See Groups and Channels	-
Group	Group	1	3 (M)	-
Value	Unsigned Integer	2	0 = Off 1 = On 2 = Toggle (Null to query in text)	-

PACEN – PA Softclipper Enable

This command changes enables the softclipper function on a power amplifier channel.

Command Form: **DEVICE PACEN** <Channel> [Value]

Argument	Type	Size	Values	Units
Channel	Channel	1	See Groups and Channels	-
Group	Group	1	23 (J)	-
Value	Unsigned Short	2	0 = Off 1 = On 2 = Toggle (Null to query in text)	-

PAENERGY – PA Energy-saver mode

This command switches the 36-volt rails off and on for the power amplifier. It is intended to be used for a low power or energy saving mode.

Command Form: **DEVICE PAENERGY** [Value]

Argument	Type	Size	Values	Units
Channel	Channel	1	See Groups and Channels	-
Group	Group	1	23 (J)	-
Value	Unsigned Short	2	0 = Energy Saver Mode OFF (Power Amp On) 1 = Energy Saver Mode ON (Power Amp Off) (Null to query in text)	-

PAEQEN – PA EQ Filter Enable

This command enables the EQ filter on a PA Channel

Command Form: **DEVICE PAEQEN** <Channel> <Group> [Value]

Argument	Type	Size	Values	Units
Channel	Channel	1	See Groups and Channels	-
Group	Group	1	23 (J)	-
Value	Unsigned Short	2	0 = Off 1 = On 2 = Toggle (Null to query in text)	-

PAEQRST – PA EQ Filter Reset

This command resets the EQ Level for ALL bands in the filter bank. **There is no query associated with this command.**

Command Form: **DEVICE PAEQEN** <Channel> <Group> [Value]

Argument	Type	Size	Values	Units
Channel	Channel	1	See Groups and Channels	-
Group	Group	1	23 (J)	-
Reserved	Zero	2	Zero	-

PAEQSET – PA EQ Filter Set

This command sets/reports the EQ Level for a given band in the filter bank

Command Form: **DEVICE PAEQEN** <Channel> <Group> <Band> [Value]

Argument	Type	Size	Values	Units
Channel	Channel	1	See Groups and Channels	-
Group	Group	1	23 (J)	-
Band	Unsigned Short	2	1 = 32.25 Hz 2 = 62.5 Hz 3 = 125.0 Hz 4 = 250.0 Hz 5 = 500.0 Hz 6 = 1000.0 Hz 7 = 2000.0 Hz 8 = 4000.0 Hz 9 = 8000.0 Hz 10 = 16000.0 Hz	Hz
Value	Signed Float	4	-12.00 – 12.00 (Null to query in text)	dB

PAFLT – PA Fault

This indicates one of the power amplifier channels is in a FAULT condition. **This is Read-Only, and is automatically generated if a fault occurs.**

Command Form: **DEVICE PAEQEN** [Bitmap]

Argument	Type	Size	Values
Bitmap	Hexadecimal Integer	4	<p><Bits 09 - 31 unused></p>

PAIMPED – PA Output Impedance

This command selects the output impedance for the PA channel to be either 8 ohms or 70/100V.

Command Form: **DEVICE PIAMPED** <Channel> <Group> [Value]

Argument	Type	Size	Values	Units
Channel	Channel	1	See Groups and Channels	-
Group	Group	1	23 (J)	-
Value	Unsigned Short	2	0 = 8 ohms 1 = 70/100V (Null to query in text)	-

PALEN – PA Limiter Enable

This command changes enables the Limiter on a power amplifier channel.

Command Form: **DEVICE PALEN** <Channel> <Group> [Value]

Argument	Type	Size	Values	Units
Channel	Channel	1	See Groups and Channels	-
Group	Group	1	23 (J)	-
Value	Unsigned Short	2	0 = Off 1 = On 2 = Toggle (Null to query in text)	-

PALT – PA Limiter Threshold

This command sets the Limiter threshold on a power amplifier channel.

Command Form: **DEVICE PALT** <Channel> <Group> [Value]

Argument	Type	Size	Values	Units
Channel	Channel	1	See Groups and Channels	-
Group	Group	1	23 (J)	-
Value	Signed Float	2	-65.00 to +20.00 (Null to query in text)	dB

PANGAT – PA Noise Gate Activation Timer

This command sets the Noise Gate activation timer. The noise gate will be activated if the timer conditions are met along with Gate thresholds.

Command Form: **DEVICE PANGAT** <Channel> <Group> [Value]

Argument	Type	Size	Values	Units
Channel	Channel	1	See Groups and Channels	-
Group	Group	1	23 (J)	-
Value	Unsigned Short	2	1 -16 (Null to query in text)	Minutes

PANGEN – PA Noise Gate Enabled

This command enables noise gating on a PA Channel.

Command Form: **DEVICE PANGEN** <Channel> <Group> [Value]

Argument	Type	Size	Values	Units
Channel	Channel	1	See Groups and Channels	-
Group	Group	1	23 (J)	-
Value	Unsigned Short	2	0 = No Filter 1 = High Pass 2 = Low Pass 3 = Hi and Low Pass (Null to query in text)	-

PANGF – PA Noise Gate Filter

This command sets either a High Pass or Low Pass filter to be used in the activation of the noise gate. This will affect the threshold conditions for activation of the gate. A low pass will remove noise floor contributions to gate threshold above **500 HZ**. A high pass will remove noise floor contribution to gate threshold above below **2K**.

Command Form: **DEVICE PANGF** <Channel> <Group> [Value]

Argument	Type	Size	Values	Units
Channel	Channel	1	See Groups and Channels	-
Group	Group	1	23 (J)	-
Value	Unsigned Short	2	0 = Off 1 = On 2 = Toggle (Null to query in text)	-

PANGM – PA Noise Gate Mode

This command sets the Noise Gate mode to be either manual or automatic. In manual mode the gate threshold will be used to activate. In auto mode the noise floor will be used to activate.

Command Form: **DEVICE PANGM** <Channel> <Group> [Value]

Argument	Type	Size	Values	Units
Channel	Channel	1	See Groups and Channels	-
Group	Group	1	23 (J)	-
Value	Unsigned Short	2	0 = Automatic 1 = Manual (Null to query in text)	-

PANGT – PA Noise Gate Threshold

This command sets the Noise Gate Threshold that will be used when in the manual mode. This represents the level at which the noise gate will activate.

Command Form: DEVICE PANGT <Channel> <Group> [Value]

Argument	Type	Size	Values	Units
Channel	Channel	1	See Groups and Channels	-
Group	Group	1	23 (J)	-
Value	Signed Float	2	-100.00 to 0.00 (Null to query in text)	dB

PAPOL – Polarity Switch

This command changes audio signal polarity on a power amplifier channel.

Command Form: DEVICE PAPOL <Channel> <Group> [Value]

Argument	Type	Size	Values	Units
Channel	Channel	1	See Groups and Channels	-
Group	Group	1	23 (J)	-
Value	Unsigned Short	2	0 = Normal 1 = Reverse 2 = Toggle (Null to query in text)	-

PARST – PA Reset

This command resets the power supplies on an individual power amplifier circuits. **There is no query associated with this command.**

Command Form: DEVICE PARST <Channel> <Group> [Value]

Argument	Type	Size	Values	Units
Channel	Channel	1	See Groups and Channels	-
Group	Group	1	23 (J)	-
Reserved	Zero	2	Zero	-

PASME – PA Sound Mask Enable

This command enables the sound mask signal on a PA Channel

Command Form: DEVICE PASME <Channel> <Group> [Value]

Argument	Type	Size	Values	Units
Channel	Channel	1	See Groups and Channels	-
Group	Group	1	23 (J)	-
Value	Unsigned Short	2	0 = Voice Mode 1 = Wideband Mode (Null to query in text)	-

PASML – PA Sound Mask Level

This command selects/reports the sound mask level on a PA channel.

Command Form: DEVICE PASML <Channel> <Group> [Amplitude]

Argument	Type	Size	Values	Units
Channel	Channel	1	See Groups and Channels	-
Group	Group	1	23 (J)	-
Amplitude	Signed Short	2	-60.00 – 20.00 (Null to query in text)	dB

PASMM – PA Sound Mask Mode

This command selects/reports the sound mask mode on a PA channel.

Command Form: **DEVICE PASMM** <Channel> <Group> [Value]

Argument	Type	Size	Values	Units
Channel	Channel	1	See Groups and Channels	-
Group	Group	1	23 (J)	-
Value	Unsigned Short	2	0 = Voice Mode 1 = Wideband Mode (Null to query in text)	-

PASMT – PA Sound Mask Timer

This command selects/reports the timer on sound mask signal on a PA channel.

Command Form: **DEVICE PASMT** <Channel> <Group> [Value]

Argument	Type	Size	Values	Units
Channel	Channel	1	See Groups and Channels	-
Group	Group	1	23 (J)	-
Value	Unsigned Short	2	0 – 1440 (24 hours) (Null to query in text)	Minutes

PATO – PA Thermal Overload

This indicates if a thermal overload condition is occurring on one of the power amplifier channels. **This is Read-Only, and is automatically generated if a overload occurs.**

Command Form: **DEVICE PATO** [Bitmap]

Argument	Type	Size	Values	Units
Bitmap	Hexa-decimal Integer	4	<p><Bits 03 - 31 unused></p>	-

PBDIAL – Dial a PB Entry by Argument

This command dials a speed dial number by name. **There is no query for this command.**

Command Form: **DEVICE PBDIAL** <Channel> <Label>

Argument	Type	Size	Values	Units
Channel	Channel	1	See Groups and Channels	-
Group	Group	1	17 (R)	-
Reserved	Unsigned Integer	2	0	-
Label	String	16	1 – 16 chars	-

PHONEBOOKADD – Adds an Entry to the Phonebook

This command saves an entry in the phonebook. **There is no query for this command.** No two entries can share the same label. An argument error will be returned if an entry already exists. To change an entry, you must first delete it and then add it again. If label is blank, the first 20 characters of the number will be used as the label. The **Number** argument must not be blank. If an entry already exists with the assigned speed dial it will be overwritten. The entries are alphabetized based on Label.

Command Form: **DEVICE PHONEBOOKADD** <ID Number Label>

Argument	Type	Size	Values	Units
Speed Dial	Unsigned Integer	4	0 for not assigned to a speed dial 1 – 20	-
Number	String	44	1 – 44 chars '0' – '9', '*', '#'	-
Label	String	16	1 – 16 chars	-

PHONEBOOKCNT – Counts Entries in the Phonebook

This command queries the number of entries in the phonebook. **This command is query only.**

Command Form: *DEVICE* **PHONEBOOKCNT** <Value>

Argument	Type	Size	Values	Units
Value	Unsigned Integer	4	0 – 20	-

PHONEBOOKDEL – Deletes an Entry in the Phonebook

This command deletes an entry in the phonebook. **There is no query for this command.**

Command Form: *DEVICE* **PHONEBOOKDEL** <Label>

Argument	Type	Size	Values	Units
Label	String	16	1 – 16 chars	-

PHONEBOOKREAD – Queries the Phonebook by Index

This command queries an entry in the phonebook. **This command is query only.**

Command Form: *DEVICE* **PHONEBOOKREAD** <Index> [Speed Number Label]

Argument	Type	Size	Values	Units
Index	Unsigned Integer	2	0 – 19 (Must be less than the Number of Phone Book Entries)	-
Speed Dial	Unsigned Integer	2	0 for not assigned to a speed dial 1 – 20 (NULL to query in text)	-
Number	String	44	1 – 44 chars '0' – '9', '*', '#'	-
Label	String	16	1 – 16 chars	-

PP – Phantom Power

This command selects/reports the setting of phantom power.

Command Form: *DEVICE* **PP** <Channel> [Value]

Argument	Type	Size	Values	Units
Channel	Channel	1	See Groups and Channels	-
Group	Group	1	3 (M)	-
Value	Unsigned Integer	2	0 = Off 1 = On 2 = Toggle (Null to query in text)	-

PRESET – Preset Execution/Reporting

This command selects/reports the state of a preset.

Command Form: *DEVICE* **PRESET** <Channel> [Value]

Argument	Type	Size	Values	Units
Channel	Channel	1	0 (Binary)/Null (Text) = Query Last Preset Ran See Groups and Channels	-
Group	Group	1	13 (S)	-
Value	Unsigned Integer	2	0 = Set preset state to off 1 = Set state to on and execute if not already on 2 = Execute and return state to off (Null to query current state in text)	-

PRGSTRING – Program String

This command sets/reports a programmed string.

COMMAND FORM: **DEVICE PRGSTRING** <ID> [Value]

Argument	Type	Size	Values	Units
ID	Unsigned Integer	4	0 – 7	-
Value	String	80	CLEAR = Clear current value 1 – 80 Chars (Null to query in text) Special Characters: \a = alert \b = backspace \f = form feed \n = new line \r = carriage return \t = horizontal tab \v = vertical tab \ = backslash	-

PROXYSTAT – Proxy Registration Status

This command reports the registration status for the primary or secondary proxy. **This command is only queried, not set, and can be sent asynchronously.**

Command Form: **DEVICE PROXYSTAT** <Index> <Value>

Argument	Type	Size	Values	Units
Index	Channel Index	1	0 = Primary Proxy 1 = Secondary Proxy	-
Group	Group	1	129 (No text group)	-
Value	Signed Float	2	0 = SIP Proxy Disabled 1 = SIP Proxy Registered 2 = SIP Proxy NOT Registered	-

PROXYTYPE – Set/Get Proxy Type

If the proxy server requires specific firmware changes to work with, this setting tells firmware what proxy server type to work with.

Command Form: **DEVICE PROXYTYPE** <Value>

Argument	Type	Size	Values	Units
Const. Channel	Channel Const.	1	1	-
Group	Group	1	131	-
Value	Signed Float	2	0 – Default, means no specific changes required. 1 – Cisco Proxy (CCM7)	-

PTTTHRESHOLD – Push to Talk Threshold

This command selects/reports the setting of the push to talk threshold for a microphone.

Command Form: **DEVICE PTTTHRESHOLD** <Channel> [Value]

Argument	Type	Size	Values	Units
Channel	Channel	1	See Groups and Channels	-
Group	Group	1	3 (M)	-
Value	Float	2	-100 to 0 (Null to query in text)	dB

PUSHTOTALK – Push to Talk

This command selects/reports the setting of push-to-talk for a microphone.

Command Form: DEVICE **PUSHTOTALK** <Channel> [Value]

Argument	Type	Size	Values	Units
Channel	Channel	1	See Groups and Channels	-
Group	Group	1	3 (M)	-
Value	Unsigned Integer	2	0 = Off 1 = On 2 = Toggle (Null to query in text)	-

RAMP – Ramp Gain Adjustment

This command starts / stops the gain ramp for an input, output or assignable processing block. **There is no query associated with this command.**

Command Form: DEVICE **RAMP** <Channel> <Group> <Rate> [Target]

Argument	Type	Size	Values	Units
Channel	Channel	1	See Groups and Channels	-
Group	Group	1	1, 2, 3, 5, 7, 12, 16, 17, 25, 26 (I, J, O, M, P, L, F, T, R, K, Z, D, U, V)	-
Rate	Signed Integer	1	-50 – 50 If value=0, the ramp will stop. If value< 0, the gain will ramp down. If value>0, the gain will ramp up.	dB / s
Target	Signed Integer	1	-65 – 20 If NULL in text or 0x80 in binary, the ramp will use the channel's maximum and minimum for a target.	dB

REDIAL – Redial the Last Number

This command redials the last number. **There is no query for this command.**

Command Form: DEVICE **REDIAL** <Channel>

Argument	Type	Size	Values	Units
Channel	Channel	1	See Groups and Channels	-
Group	Group	1	17 (R)	-
Reserved		2	0	-

REFSEL – Reference Select for PA Adaptation & AEC

This command selects/reports which output or expansion bus reference is used for a Mic input as a reference for power amp adaptation mode and acoustic echo cancellation where applicable.

Command Form: DEVICE **REFSEL** <Channel> [Ref. Group Ref. Channel]

Argument	Type	Size	Values	Units
Channel	Channel	1	See 3 (M) in Groups and Channels	-
Group	Group	1	3 (M)	-
Reference Group	Group	1	2, 8, 20 (A, B, E, H, J, O)	-
Reference Channel	Channel	1	See Groups and Channels (Null to query in text)	-

REFSET – Reference Channel Set Up

This command selects/reports the output the reference channel tracks.

Command Form: DEVICE **REFSET** <Channel> [Reference Output]

Argument	Type	Size	Values	Units
Channel	Channel	1	See Groups and Channels	-
Group	Group	1	20 (B)	-
Value	Reference Output	2	0 = none See 2 (O) in Groups and Channels (Null to query in text)	-

RESET – Reset

Resets the unit. **There is no query for this command.**

Command Form: `DEVICE RESET`

No Arguments

RING – Ring Indication

This command indicates a ringing line. **This command is reportable only. It cannot be queried or set.**

Command Form: `DEVICE RING <Channel> <Value>`

Argument	Type	Size	Values	Units
Channel	Channel	1	See Groups and Channels	-
Group	Group	1	17 (R)	-
Value	Unsigned Integer	2	0 = Ring Cycle Ended 1 = Ring Cycle Started	-

RINGEREN – Audible Ring Enable

This command sends/reports the use of an audible ring.

Command Form: `DEVICE RINGEREN <Channel> [Value]`

Argument	Type	Size	Values	Units
Channel	Channel	1	See Groups and Channels	-
Group	Group	1	17 (R)	-
Value	Unsigned Integer	2	0 = Off 1 = On 2 = Toggle (Null to query in text)	-

RINGERLVL – Audible Ring Level

This command selects/reports the audible ring's level.

Command Form: `DEVICE RINGERLVL <Channel> [Value]`

Argument	Type	Size	Values	Units
Channel	Channel	1	See Groups and Channels	-
Group	Group	1	17 (R)	-
Value	Signed Float	2	-12.00 – 12.00 (dB) (Null to query in text)	-

RINGERSEL – Audible Ring Melody Selection

This command sends/reports the audible ring melody.

Command Form: `DEVICE RINGERSEL <Channel> [Value]`

Argument	Type	Size	Values	Units
Channel	Channel	1	See Groups and Channels	-
Group	Group	1	17 (R)	-
Value	Unsigned Integer	2	1 – 3 (Null to query in text)	-

RINGERTEST – Audible Ring Melody Test

This command plays the current audible ringer melody. **This command is executable only. There is no query.**

Command Form: `DEVICE RINGERTEST <Channel>`

Argument	Type	Size	Values	Units
Channel	Channel	1	See Groups and Channels	-
Group	Group	1	17 (R)	-
Reserved	Unsigned Integer	2	0	-

RINGMOD – Ring Cadence Mode

This command sets the ring cadence to either standard mode or custom mode. The cadence can be set using the RINGON and RINGOFF commands. The country code should be set first using the COUNTRY command.

Command Form: **DEVICE RINGMOD** <Channel> <Group> [Value]

Argument	Type	Size	Values	Units
Channel	Channel	1	See Groups and Channels	-
Group	Group	1	17 (R)	-
Value	Unsigned Short	2	0 = Standard 1 = Custom (Null to query in text)	-

RINGOFF – Ring Cadence Off Time

This command sets the ring cadence off time. The country code should be set first using the COUNTRY command.

Command Form: **DEVICE RINGOFF** <Channel> <Group> [Value]

Argument	Type	Size	Values	Units
Channel	Channel	1	See Groups and Channels	-
Group	Group	1	17 (R)	-
Value	Unsigned Short	2	0 = 80 1 = 128 2 = 256 3 = 384 4 = 512 5 = 640 6 = 768 7 = 896 8 = 1024 (Null to query in text)	ms

RINGON – Ring Cadence On Time

This command sets the ring cadence on time. The country code should be set first using the COUNTRY command.

Command Form: **DEVICE RINGON** <Channel> <Group> [Value]

Argument	Type	Size	Values	Units
Channel	Channel	1	See Groups and Channels	-
Group	Group	1	17 (R)	-
Value	Unsigned Short	2	0 = 100 1 = 150 2 = 200 3 = 256 4 = 384 5 = 512 6 = 640 7 = 1024 (Null to query in text)	ms

RXBOOST – Receive Boost

This command selects/reports the receive boost status.

Command Form: **DEVICE RXBOOST** <Channel> [Value]

Argument	Type	Size	Values	Units
Channel	Channel	1	See Groups and Channels	-
Group	Group	1	17 (R)	-
Value	Unsigned Integer	2	0, 3, 6, 9, or 12 (Null to query in text)	dB

RXBSTEN – Receive Boost Enable

This command selects/reports the receive boost status.

Command Form: *DEVICE* **RXBSTEN** <Channel> [Value]

Argument	Type	Size	Values	Units
Channel	Channel	1	See Groups and Channels	-
Group	Group	1	17 (R)	-
Value	Unsigned Integer	2	0 = Off 1 = On 2 = Toggle (Null to query in text)	-

SERECHO – Serial Echo

This command selects/reports the serial echo of the RS-232 port.

Command Form: *DEVICE* **SERECHO** [Value]

Argument	Type	Size	Values	Units
Value	Unsigned Integer	4	0 = Off 1 = On 2 = Toggle (Null to query in text)	-

NOTE: The unit will return the updated state of the last selection in the same form as the command.

SFTYMUTE – Safety Mute

This command selects/reports the state of the safety mute. Safety mute holds all outputs in a muted state. It used for syncing to a site document to avoid feedback or blown speakers until the unit is in a settled state.

Command Form: *DEVICE* **SFTYMUTE** [Value]

Argument	Type	Size	Values	Units
Value	Channel	4	0 = off 1 = on 2 = toggle (Null to query in text)	-

SIGGEN – Signal Generator

This command selects/reports of the signal generator activation.

Command Form: *DEVICE* **SIGGEN** [Channel Group Type Amplitude Frequency]

Argument	Type	Size	Values	Units
Channel	Channel	1	See Groups and Channels (Null to query in text)	-
Group	Group	1	1, 3, 7 (I, M, L)	-
Type	Unsigned Integer	2	1 = Pink Noise 2 = White Noise 3 = Tone	-
Amplitude	Signed Float	4	-60.00 – 20.00	dB
Frequency	Unsigned Float	4	Type 1 – 2 0 (Null in text) Type 3 20.00 – 20000.00	Hz

SIGGENEN – Signal Generator Enable

This command selects/reports of the signal generator activation.

Command Form: *DEVICE* **SIGGENEN** [Value]

Argument	Type	Size	Values	Units
Value	Unsigned Integer	4	0 = Off 1 = On 2 = Toggle (Null to query in text)	-

SIGGENSWEEP – Signal Generator Sweep

This command starts the signal generator with a tone and does a sweep. If **Repeat** is 0, the signal generator will turn off after the sweep. If **Repeat** is 1, the signal generator will turn off after signal generator timeout. To stop the sweep, send a SIGGENEN command with a 0. During the sweep, the box will send out updated SIGGEN commands.

Command Form:

DEVICE **SIGGENSWEEP** <Channel> <Group> <Amplitude> <Start Frequency> <End Frequency>
<Increment Frequency> <Rate> <Repeat>

Argument	Type	Size	Values	Units
Channel	Channel	1	See Groups and Channels	-
Group	Group	1	1, 3, 7 (I, M, L)	-
Amplitude	Signed Float	2	-60.00 – 20.00	dB
Start Frequency	Unsigned Float	4	20.00 – 20000.00	Hz
End Frequency	Unsigned Float	4	20.00 – 20000.00 (must be greater than the start)	Hz
Increment Frequency	Unsigned Float	4	1.00 – 20000.00	Hz
Rate	Unsigned Integer	2	10 – 2000 ms	Hz
Repeat	Unsigned Integer	2	0 = repeat off 1 = repeat on	-

SIGTOUT – Signal Generator Time Out

Sets the signal generator time out for the unit.

Command Form: DEVICE **SIGTOUT** [Value]

Argument	Type	Size	Values	Units
Value	Unsigned Integer	4	0 = Disable 1 – 30 (Null to query in text)	Min

SLVL – Speech Level Control

This command selects/reports the setting of Speech Level Control.

Command Form: DEVICE **SLVL** <Channel> [Value]

Argument	Type	Size	Values	Units
Channel	Channel	1	See Groups and Channels	-
Group	Group	1	3 (M)	-
Value	Unsigned Integer	2	0 = Off 1 = On 2 = Toggle (Null to query in text)	-

SMTPSRV – SMTP Mail Server Address

This command selects/reports the IP address of the SMTP Mail server, and the Email Address the unit's SMTP client sends messages to.

Command Form: DEVICE **SMTPSRV** [Value Address]

Argument	Type	Size	Values	Units
Value	IP Address	4	(Null to query in text) (0.0.0.0 Clears IP and String)	-
Address	String	40	1 – 40 characters (Null to query in text)	-

SNMPMNGRIP – SNMP Manager Host IP Address

This command selects/reports the IP address of the SNMP Manager.

Command Form: *DEVICE* **SNMPMNGRIP** [Value]

Argument	Type	Size	Values	Units
Value	IP Address	4	IP Address of SNMP Manager to send Traps to (Null to query in text)	-

SNMPMNGRPORT – SNMP Manager Notification Port

This command selects/reports the SNMP Trap port for SNMP Manager.

Command Form: *DEVICE* **SNMPMNGRPORT** [Value]

Argument	Type	Size	Values	Units
Value	Unsigned Integer	4	1-255 (Null to query in text)	-

SNMPREADCOMM – SNMP Read Community String

This command selects/reports the SNMP read community string.

Command Form: *DEVICE* **SNMPREADCOMM** [Value]

Argument	Type	Size	Values	Units
Value	String	30	Read Community validation string (GET data) (Null to query in text: defaults to "public")	-

SNMPWRITECOMM – SNMP Write Community String

This command selects/reports the SNMP Write Community String.

Command Form: *DEVICE* **SNMPWRITECOMM** [Value]

Argument	Type	Size	Values	Units
Value	String	30	Write Community validation string (SET data) (Null to query in text: Default = "private")	-

SPEEDDIAL – Speed Dial a Number

This command dials a speed dial number.

Command Form: *DEVICE* **SPEEDDIAL** <Channel> [Value]

Argument	Type	Size	Values	Units
Channel	Channel	1	See Groups and Channels	-
Group	Group	1	17 (R)	-
Value	Unsigned Integer	2	1 – 20 (Null to query in text)	-

STRING – String Execution

This command sends the specified string out the serial port.

Command Form: *DEVICE* **STRING** [ID]

Argument	Type	Size	Values	Units
ID	Unsigned Integer	4	0 – 7 (Null to query last string in text)	-

SYSCHECKS – System Checks

Initiates the system checks. **There is no query for this command.**

The **System Check** integer bits determine which tests are run. Each bit set generates a separate SYSRESULT response.

COMMAND FORM: *DEVICE* **SYSCHECKS** <System Check>

Argument	Type	Size	Values
System Check	Hexadecimal Integer	4	<div style="display: flex; justify-content: space-between;"> 15141312111009080706050403020100 </div> <div style="margin-top: 10px;"> <div style="display: flex; justify-content: space-between;"> <div style="width: 100%; border-left: 1px solid black; border-right: 1px solid black; height: 100px;"></div> <div style="width: 10%; text-align: center;"> <p>Network</p> <p>Telephone</p> <p>Mic 1</p> <p>Mic 2</p> <p>Mic 3</p> <p>Mic 4</p> <p>Mic 5</p> <p>Mic 6</p> <p>Mic 7</p> <p>Mic 8</p> <p>Power Amp Temp Check</p> <p>Power Amp Fault Check</p> <p>SIP Proxy Registration Status</p> <p>Packet Loss Statistics</p> </div> </div> <p style="margin-top: 10px;">All other bits reserved</p> </div>

SYSRESULT – System Check Result

This command reports the results of the system check. **This command is reportable only. It cannot be queried or set.** The **System Check** integer bits determine which test result will be reported. Each test results in a separate SYSRESULT message.

Argument	Type	Size	Values
System Check	Hexadecimal Integer	4	<div style="display: flex; justify-content: space-between;"> 15141312111009080706050403020100 </div> <p>All other bits reserved</p>
Status	Unsigned Integer	2	0 = Fail 1 = Pass 2 = NULL <Not Tested or Test Disabled in SYSCONFIG>
Message	String	40	For the telephone on hook: the message will report the line voltage, the line current, other results, and if dial tone is detected. For the telephone off hook: the message will report the line current, other results, and if dial tone is detected. The bit mask for the other results is x x x x x x x x --> set if switched from CTR21 to FCC because of low current --> set if used DIAL bit while dialing --> set if switch from Low Voltage to Japan because of current --> set if switch from Low Voltage to FCC because of current --> DAA OVL status --> DAA DOD status --> DAA OPD status --> Not used

For the network check: the box will report if no IP address is set. If it is set, the box will ping the gateway. The message will say the ping failed if it is not returned in 5 s. Otherwise, the message will report how many seconds it took to return the ping.

TAMODE – Telco Adapt Mode

This command selects/reports the Telco adapt mode.

Command Form: **DEVICE TAMODE** <Channel> [Value]

Argument	Type	Size	Values	Units
Channel	Channel	1	See Groups and Channels	-
Group	Group	1	17 (R)	-
Value	Unsigned Integer	2	0 = Auto 1 = Burst (Null to query in text)	-

TE – Telco Enable

This command selects/reports the hook status.

Command Form: **DEVICE TE** <Channel> [Value]

Argument	Type	Size	Values	Units
Channel	Channel	1	See Groups and Channels	-
Group	Group	1	17 (R)	-
Value	Unsigned Integer	2	0 = Off 1 = On 2 = Toggle (Null to query in text)	-

TELCOLVCTRL – Telco RX Level Control Enable / Disable

This command selects/reports the setting of Telco Rx level control.

Command Form: **DEVICE TELCOLVCTRL** <Channel> [Value]

Argument	Type	Size	Values	Units
Channel	Channel	1	See Groups and Channels	-
Group	Group	1	17 (T)	-
Value	Unsigned Integer	2	0 = Off 1 = On 2 = Toggle (Null to query in text)	-

TELOVER – Telco Current Overload

This command reports that the Telco circuitry has experienced a current overload that has forced it to go off hook. This condition can occur because of a connection to a Digital PBX, and is done to protect the Telco Circuitry from damage. The command is a notification only, and cannot be set or queried.

Command Form: **DEVICE TELOVER** <Channel> <Overload>

Argument	Type	Size	Values	Units
Channel	Channel	1	See Groups and Channels	-
Group	Group	1	17 (R)	-
Value	Unsigned Short	2	0 = Not Overloaded 1 = OVERLOADED	-

TIMELocale – Time Locale Settings

This command sets or reports the time locale settings.

Command Form: **DEVICE TIMELOCALE** [DaylightSavings TimeZone TimeZoneName]

Argument	Type	Size	Values	Units
Daylight Savings	Unsigned Integer	4	0 = Do not use Daylight Savings 1 = Use Daylight Savings (NULL to Query in Text)	-
Time Zone	Unsigned Integer	4	The number of seconds from UDT. (-86400 – 86400)	-
Time Zone Argument	String	32	Description of time zone	-

TOUT – Time Out Select

This command selects/reports the inactivity time out before returning to the unit title screen on the front panel.

Command Form: *DEVICE TOUT* [Value]

Argument	Type	Size	Values	Units
Value	Unsigned Integer	4	0 = No Time Out 1 – 15 (Null to query in text)	Min

UID – Unit ID

This command reports the unit id. **This command is read only.**

Command Form: *DEVICE UID* [Value]

Argument	Type	Size	Values	Units
Value	Hexadecimal	4	(Sent with a Null, value returned in text)	-

VER - Version

This command reports the version of the unit. **This command is read only.**

Command Form: *DEVICE VER* [Value]

Argument	Type	Size	Values	Units
Value	String	8	Version of format MM.mm.rr (Sent with a Null in text, value returned)	-

XAA – Auto Answer Enable/Disable

This command selects/reports the setting of auto answer. This command can be used to replace the AA command for the R group.

Command Form: *DEVICE XAA* <Channel> <Group> [Value]

Argument	Type	Size	Values	Units
Channel	Channel	1	See Groups and Channels	-
Group	Group	1	17, 26 (R, Z)	-
Value	Unsigned Short	2	0 = Off 1 = On 2 = Toggle (Null to query in text)	-

XAAMB – Adaptive Ambient Mode

This command selects/reports the setting of adaptive ambient. This command can be used to replace the AAMB command for the M group.

Command Form: *DEVICE XAAMB* <Channel> <Group> [Value]

Argument	Type	Size	Values	Units
Channel	Channel	1	See Groups and Channels	-
Group	Group	1	3, 29 (M, V)	-
Value	Unsigned Short	2	0 = Off 1 = On 2 = Toggle (Null to query in text)	-

XAMBLVL – Ambient Level Adjust

This command selects/reports the ambient level. This command can be used to replace the AMBLVL command for the M group.

Command Form: *DEVICE XAMBLVL* <Channel> <Group> [Value]

Argument	Type	Size	Values	Units
Channel	Channel	1	See Groups and Channels	-
Group	Group	1	3, 29 (M, V)	-
Value	Signed Float	2	-80.00 – 0.00 (Null to query in text)	dB

XAARINGS – Number of Rings to Auto Answer On

This command selects/reports the setting of the number of rings to auto answer. This command can be used to replace the AARINGS command for the R group.

Command Form: DEVICE **XAARINGS** <Channel> <Group> [Value]

Argument	Type	Size	Values	Units
Channel	Channel	1	See Groups and Channels	-
Group	Group	1	17, 26 (R, Z)	-
Value	Unsigned Short	2	2-4 (Null to query in text)	-

XACONN – Audible Connect / Disconnect Indication

This command selects/reports the status of the audible connect / disconnect indication. This command can be used to replace the ACONN command for the R group.

Command Form: DEVICE **XACONN** <Channel> <Group> [Value]

Argument	Type	Size	Values	Units
Channel	Channel	1	See Groups and Channels	-
Group	Group	1	17, 26 (R, Z)	-
Value	Unsigned Short	2	0 = Off 1 = On 2 = Toggle (Null to query in text)	-

XACONNLVL – Audible Connect / Disconnect Level

This command selects/reports the audible connect / disconnect indicator's level. This command can be used to replace the ACONNLVL command for the R group.

Command Form: DEVICE **XACONNLVL** <Channel> <Group> [Value]

Argument	Type	Size	Values	Units
Channel	Channel	1	See Groups and Channels	-
Group	Group	1	17, 26 (R, Z)	-
Value	Signed Short	2	-12.00 – 12.00 (Null to query in text)	dB

XCALLDUR – Call Duration

This command indicates how long a call has lasted. If no call is in session, this will report 0. At the time of call termination, this command will automatically be sent out reporting the duration. This command can be used to replace the CALLDUR command for the R group.

Command Form: DEVICE **XCALLDUR** <Channel> <Group> <Number> <Name>

Argument	Type	Size	Values	Units
Channel	Channel	1	See Groups and Channels	-
Group	Group	1	17, 26 (R, Z)	-
Number	String	44	1-44 Characters	-
Name	String	44	1-44 Characters	-

XCALLERID – Reports Caller ID Information

This command reports Caller Identification Information. This command can be used to replace the CALLERID command for the R group. **This command is reportable only. It cannot be queried or set.**

Command Form: DEVICE **XCALLERID** <Channel> <Group> <Duration>

Argument	Type	Size	Values	Units
Channel	Channel	1	See Groups and Channels	-
Group	Group	1	17, 26 (R, Z)	-
Reserved	Unsigned Short	2	0	-
Duration	String	8	String of format HR:MN:SS	-

XCHAIR0 – Chairman Override Mode

This command selects/reports the setting of chairman override. This command can be used to replace the CHAIR0 command for the M group.

Command Form: *DEVICE XCHAIR0* <Channel> <Group> [Value]

Argument	Type	Size	Values	Units
Channel	Channel	1	See Groups and Channels	-
Group	Group	1	3, 29 (M, V)	-
Value	Unsigned Short	2	0 = Off 1 = On 2 = Toggle (Null to query in text)	-

XCGROUP – Compressor Group

This command sets the compressor group for synchronized operation of the compressor. This command can be used to replace the CGROUP command for the P group.

Command Form: *DEVICE XCGROUP* <Channel> <Group> [Value]

Argument	Type	Size	Values	Units
Channel	Channel	1	See Groups and Channels	-
Group	Group	1	5, 23 (P, J)	-
Value	Unsigned Short	2	0 = None 1 = Group 1 2 = Group 2 3 = Group 3 4 = Group 4 (Null to query in text)	-

XCOMPRESS – Compressor Adjust

This command controls/reports the signal compression setting on a Channel. This command can be used to replace the COMPRESS command for the P group.

Command Form: *DEVICE XCOMPRESS* <Channel> <Group> [Value]

Argument	Type	Size	Values	Units
Channel	Channel	1	See Groups and Channels	-
Group	Group	1	23 (J, P)	-
Value	Unsigned Short	2	0 = Off 1 = On 2 = Toggle (Null to query in text)	-

XCOMPSEL – Compressor Enable

This command enables signal compression on a Channel. This command can be used to replace the COMPSEL command for the P group.

Command Form: *DEVICE XCOMPSEL* <Channel> <Group> [Value]

Argument	Type	Size	Values	Units
Channel	Channel	1	See Groups and Channels	-
Group	Group	1	23 (J, P)	-
Value	Unsigned Short	2	0 = Off 1 = On 2 = Toggle (Null to query in text)	-

XDECAY – Decay Adjust

This command selects/reports the setting of the decay rate. This command can be used to replace the DECAY command for the M group.

Command Form: DEVICE **XDECAY** <Channel> <Group> [Value]

Argument	Type	Size	Values	Units
Channel	Channel	1	See Groups and Channels	-
Group	Group	1	3, 29 (M, V)	-
Value	Unsigned Short	2	1 = Slow 2 = Medium 3 = Fast (Null to query in text)	-

XDELAY – Audio Delay

This command controls/reports signal delay on a Channel. This command can be used to replace the DELAY command for the P group.

Command Form: DEVICE **XDELAY** <Channel> <Group> [Value]

Argument	Type	Size	Values	Units
Channel	Channel	1	See Groups and Channels	-
Group	Group	1	5, 23 (P, J)	-
Value	Unsigned Short	2	0.0 – 250.00 (Null to query in text)	ms

XDELAYSEL – Audio Delay Enable

This command enables signal delay on a Channel. This command can be used to replace the DELAYSEL command for the P group.

Command Form: DEVICE **XDELAYSEL** <Channel> <Group> [Value]

Argument	Type	Size	Values	Units
Channel	Channel	1	See Groups and Channels	-
Group	Group	1	5, 23 (P, J)	-
Value	Unsigned Short	2	0 = Off 1 = On 2 = Toggle (Null to query in text)	-

XDELAYSEL – Audio Delay Enable

This command enables signal delay on a Channel. This command can be used to replace the DELAYSEL command for the P group.

Command Form: DEVICE **XDELAYSEL** <Channel> <Group> [Value]

Argument	Type	Size	Values	Units
Channel	Channel	1	See Groups and Channels	-
Group	Group	1	5, 23 (P, J)	-
Value	Unsigned Short	2	0 = Off 1 = On 2 = Toggle (Null to query in text)	-

XDIAL – DTMF Dialing

This command dials a DTMF sequence or reports back the last sequence dialed. This command can be used to replace the DIAL command for the R group.

Command Form: **DEVICE XDIAL** <Channel> <Group> [Number]

Argument	Type	Size	Values	Units
Channel	Channel	1	See Groups and Channels	-
Group	Group	1	17, 26 (R, Z)	-
Reserved	Unsigned Short	2	0	-
Number	String	44	1 – 44 Chars of '0' – '9', '*', '#', ',', (Null to query in text)	-

XDTMFLVL – DTMF Tone Level

This command selects/reports the DTMF tone's level. This command can be used to replace the DTMFLVL command for the R group. You can't change level during a call.

Command Form: **DEVICE XDTMFLVL** <Channel> <Group> [Value]

Argument	Type	Size	Values	Units
Channel	Channel	1	See Groups and Channels	-
Group	Group	1	17, 26 (R, Z)	-
Value	Signed Short	2	-12.00 – 12.00 (Null to query in text)	dB

XDTONELVL – Dial Tone Level

This command selects/reports the audible dial tone's level. This command can be used to replace the DTONELVL command for the R group. You can't change level during a call.

Command Form: **DEVICE XDTONELVL** <Channel> <Group> [Value]

Argument	Type	Size	Values	Units
Channel	Channel	1	See Groups and Channels	-
Group	Group	1	17, 26 (R, Z)	-
Value	Signed Short	2	-12.00 – 12.00 (Null to query in text)	dB

XGHOLD – Gate Hold Time Adjust

This command selects/reports the setting of hold time. This command can be used to replace the GHOLD command for the M group.

Command Form: **DEVICE XGHOLD** <Channel> <Group> [Value]

Argument	Type	Size	Values	Units
Channel	Channel	1	See Groups and Channels	-
Group	Group	1	3, 29 (M, V)	-
Value	Unsigned Short	2	0.10 – 8.00 (Null to query in text)	S

XGMODE – Gating Mode

This command selects/reports the setting of gating mode. This command can be used to replace the GMODE command for the M group.

Command Form: **DEVICE XGMODE** <Channel> <Group> [Value]

Argument	Type	Size	Values	Units
Channel	Channel	1	See Groups and Channels	-
Group	Group	1	3, 29 (M, V)	-
Value	Unsigned Short	2	0.10 – 8.00 (Null to query in text)	-

XGOVER – Gating Override

This command selects/reports the setting of gating override. This command can be used to replace the GOVER command for the M group.

Command Form: DEVICE **XGOVER** <Channel> <Group> [Value]

Argument	Type	Size	Values	Units
Channel	Channel	1	See Groups and Channels	-
Group	Group	1	3, 29 (M, V)	-
Value	Unsigned Short	2	0 = Off 1 = On 2 = Toggle (Null to query in text)	-

XGRATIO – Gate Ratio Adjust

This command selects/reports the setting of the gate ratio. This command can be used to replace the GRATIO command for the M group.

Command Form: DEVICE **XGRATIO** <Channel> <Group> [Value]

Argument	Type	Size	Values	Units
Channel	Channel	1	See Groups and Channels	-
Group	Group	1	3, 29 (M, V)	-
Value	Unsigned Short	2	0 – 50 (Null to query in text)	dB

XGRPSEL – Gating Group Select

This command selects/reports which Gating Group a microphone input is assigned. This command can be used to replace the GRPSEL command for the M group.

Command Form: DEVICE **XGRPSEL** <Channel> <Group> [Value]

Argument	Type	Size	Values	Units
Channel	Channel	1	See Groups and Channels	-
Group	Group	1	3, 29 (M, V)	-
Value	Unsigned Short	2	See 4 (G) in Group and Channels (Null to query in text)	-

XHOOK – Hook Flash

This command sends a hook flash. This command can be used to replace the HOOK command for the R group. **There is no query for this command.**

Command Form: DEVICE **XHOOK** <Channel> <Group> <Reserved>

Argument	Type	Size	Values	Units
Channel	Channel	1	See Groups and Channels	-
Group	Group	1	17, 26 (R, Z)	-
Reserved	Unsigned Short	2	0	-

XHOOKD – Hook Flash Duration

This command selects/reports the hook flash duration. This command can be used to replace the HOOKD command for the R group.

Command Form: DEVICE **XHOOKD** <Channel> <Group> <Reserved>

Argument	Type	Size	Values	Units
Channel	Channel	1	See Groups and Channels	-
Group	Group	1	17, 26 (R, Z)	-
Reserved	Unsigned Short	2	50 – 2000 (Multiples of 10 Ms only) (Null to query in text)	Ms

XLOCALNUM – Local Number

This command sets or reports back the current value of the local number. This command can be used to replace the LOCALNUM command for the R group.

Command Form: DEVICE **XLOCALNUM** <Channel> <Group> [Number]

Argument	Type	Size	Values	Units
Channel	Channel	1	See Groups and Channels	-
Group	Group	1	17, 26 (R, Z)	-
Reserved	Unsigned Short	2	0	-
Number	String	16	1 – 16 Chars of '0' – '9', '*', '#', ',',	-

XOFFA – Off Attenuation Mode

This command selects/reports the off attenuation value of a Mic channel. This command can be used to replace the OFFA command for the M group.

Command Form: DEVICE **XOFFA** <Channel> <Group> [Value]

Argument	Type	Size	Values	Units
Channel	Channel	1	See Groups and Channels	-
Group	Group	1	3, 29 (M, V)	-
Value	Unsigned Float	2	0.00 – 60.00 (Null to query in text)	-

XPBDIAL – Dial a PB Entry by Name

This command dials a speed dial number by name. This command can be used to replace the PBDIAL command for the R group. **There is no query for this command.**

Command Form: DEVICE **XPBDIAL** <Channel> <Group> <Label>

Argument	Type	Size	Values	Units
Channel	Channel	1	See Groups and Channels	-
Group	Group	1	17, 26 (R, Z)	-
Reserved	Unsigned Short	2	0	-
Number	String	16	1 – 16 Chars	-

XREDIAL – Dial the last number again

This command redials the last number. This command can be used to replace the REDIAL command for the R group. **There is no query for this command.**

Command Form: DEVICE **XREDIAL** <Channel> <Group>

Argument	Type	Size	Values	Units
Channel	Channel	1	See Groups and Channels	-
Group	Group	1	17, 26 (R, Z)	-
Reserved	Unsigned Short	2	0	-

XRING – Ring Indication

This command indicates a ringing line. This command can be used to replace the RING command for the R group. **This command is reportable only. It cannot be queried or set.**

Command Form: DEVICE **XRING** <Channel> <Group> <Value>

Argument	Type	Size	Values	Units
Channel	Channel	1	See Groups and Channels	-
Group	Group	1	17, 26 (R, Z)	-
Value	Unsigned Short	2	0 = Ring Cycle Ended 1 = Ring Cycle Started	-

XRINGEREN – Audible Ring Enable

This command sends/reports the use of an audible ring. This command can be used to replace the RINGEREN command for the R group.

Command Form: **DEVICE XRINGEREN** <Channel> <Group> [Value]

Argument	Type	Size	Values	Units
Channel	Channel	1	See Groups and Channels	-
Group	Group	1	17, 26 (R, Z)	-
Value	Unsigned Short	2	0 = Off 1 = On 2 = Toggle (Null to query in text)	-

XRINGERLVL – Audible Ring Level

This command selects/reports the audible ring's level. This command can be used to replace the RINGERLVL command for the R group. You cannot change this value while the phone is ringing.

Command Form: **DEVICE XRINGERLVL** <Channel> <Group> [Value]

Argument	Type	Size	Values	Units
Channel	Channel	1	See Groups and Channels	-
Group	Group	1	17, 26 (R, Z)	-
Value	Unsigned Short	2	-12.00 – 12.00 (dB) (Null to query in text)	dB

XRINGERSEL – Audible Ring Melody Selection

This command sends/reports the audible ring melody. This command can be used to replace the RINGERSEL command for the R group. You can't change the value while phone is ringing.

Command Form: **DEVICE XRINGERSEL** <Channel> <Group> [Value]

Argument	Type	Size	Values	Units
Channel	Channel	1	See Groups and Channels	-
Group	Group	1	17, 26 (R, Z)	-
Value	Unsigned Short	2	1 – 5 (Null to query in text)	-

XRINGertest – Audible Ring Melody Test

This command plays the current audible ringer melody. This command can be used to replace the RINGertest command for the R group. **This command is executable only. There is no query.**

Command Form: **DEVICE XRINGertest** <Channel> <Group>

Argument	Type	Size	Values	Units
Channel	Channel	1	See Groups and Channels	-
Group	Group	1	17, 26 (R, Z)	-
Reserved	Unsigned Short	2	0	-

XSLVL – Speech Level Control

This command selects/reports the setting of Speech Level Control. This command can be used to replace the SLVL command for the M group.

Command Form: **DEVICE XSLVL** <Channel> <Group> [Value]

Argument	Type	Size	Values	Units
Channel	Channel	1	See Groups and Channels	-
Group	Group	1	3, 29 (M, V)	-
Value	Unsigned Short	2	0 = Off 1 = On 2 = Toggle (Null to query in text)	-

XSPEEDDIAL – Speed Dialing

This command dials a speed dial number. This command can be used to replace the SPEEDDIAL command for the R group.

Command Form: **DEVICE XSPEEDDIAL** <Channel> <Group> [Value]

Argument	Type	Size	Values	Units
Channel	Channel	1	See Groups and Channels	-
Group	Group	1	17, 26 (R, Z)	-
Value	Unsigned Short	2	1 – 20 (Null to query in text)	-

XTE – Telco Enable

This command selects/reports the hook status. This command can be used to replace the TE command for the R group.

Command Form: **DEVICE XTE** <Channel> <Group> [Value]

Argument	Type	Size	Values	Units
Channel	Channel	1	See Groups and Channels	-
Group	Group	1	17, 26 (R, Z)	-
Value	Unsigned Short	2	0 = Off 1 = On 2 = Toggle (Null to query in text)	-

CALL CONTROL SERIAL COMMANDS

CALLSTATUS – Report the Status of VoIP Channels

This command gives the status of the VoIP channels. **This status can be queried, and will be sent asynchronously. This command / status may NOT be set.**

Command Form Details:

DEVICE **CALLSTATUS** <Channel> <Group> <Line> [Status]

Argument	Type	Size	Values	Units
Channel	Channel	1	See GroupAndChannels	-
Group	Group	1	26 (Z)	-
Line Number	Unsigned Short	2	VoIP Line Number	-
Status	Unsigned Short	4	Status for Channel	-

Status Definition:

0x0001	IDLE	
0x0002	DIAL_TONE	
0x0004	RING_BUSY	
0x0008	CONNECTED	
0x0010	LOCAL HOLD (LHOLD)	
0x0020	REMOTE HOLD (RHOLD)	-
0x0040	LOCAL+REMOTE HOLD (LRHOLD)	
0x0080	CONFERENCED	
0x0100	CONFERENCED + LHOLD	
0x0200	CONFERENCED + RHOLD	
0x0400	CONFERENCED + LRHOLD	
0x0800	INCOMING_CALL	
0x0000	NO CALL STATUS	

CONFCANCEL – Cancels a Conference Call Bridge

This command cancels the 3-Way conference initialization and terminates the call with the 3rd party. **There is no query for this command.**

Command Form Details:

DEVICE **CONFCANCEL** <Channel> <Group>

Argument	Type	Size	Values	Units
Channel	Channel	1	See GroupAndChannels	-
Group	Group	1	26 (Z)	-
Reserved	Unsigned Short	2	0	-

CONFCOMPLETE – Completes a Conference Call Bridge

This command bridges two calls into a 3-way call. **There is no query for this command.**

Command Form Details:

DEVICE **CONFCOMPLETE** <Channel> <Group>

Argument	Type	Size	Values	Units
Channel	Channel	1	See GroupAndChannels	-
Group	Group	1	26 (Z)	-
Reserved	Unsigned Short	2	0	-

CONFSTART – Initiates a 3-Way Conference Call

This command dials a 3rd party to initiate a bridged (conferenced) call.

Command Form Details:

DEVICE CONFSTART <Channel> <Group> [Value]

Argument	Type	Size	Values	Units
Channel	Channel	1	See GroupAndChannels	-
Group	Group	1	26 (Z)	-
Reserved	Unsigned Short	2	0	-
Value	String	45	1 – 44 Characters of '0' – '9', '*', '#' and ',' plus NULL (Null to query in text)	-

HOLD – Places a Call on Hold

This command places the current call on hold. State tracking is provided by the CALLSTATUS command.

Command Form Details:

DEVICE HOLD <Channel> <Group>

Argument	Type	Size	Values	Units
Channel	Channel	1	See GroupAndChannels	-
Group	Group	1	26 (Z)	-

MULTILNEN – VoIP Multi-Line Enable

This command sets/reports an environmental variable which selects if the VoIP operates in single-line mode or multi-line mode. This command requires a reboot of the unit to take effect. The current state of operation of the unit can be queried using the MULTILNSTAT command.

Command Form Details:

DEVICE MULTILNEN <Channel> <Group> [Value]

Argument	Type	Size	Values	Units
Channel	Channel	1	See GroupAndChannels	-
Group	Group	1	26 (Z)	-
Value	Unsigned Short	2	0 = Single Line 1 = Multi-Line 2 = Toggle (NULL to Query in Text)	-

MULTILNSTAT – VoIP Multi-Line Status

This command reports the current mode of operation of the VoIP interface. The current state of operation is set once on boot up. To change the state of operation (single/multi) line, use the MULTILNEN command and reboot the unit. This command is query only.

Command Form Details:

DEVICE MULTILNSTAT <Channel> <Group> [Value]

Argument	Type	Size	Values	Units
Channel	Channel	1	See GroupAndChannels	-
Group	Group	1	26 (Z)	-
Value	Unsigned Short	2	0 = Single Line 1 = Multi-Line (NULL to Query in Text)	-

TRANSCANCEL – Cancels a Transferred Call

This command interrupts/stops a transfer. **There is no query for this command.**

Command Form Details:

DEVICE **TRANSCANCEL** <Channel> <Group>

Argument	Type	Size	Values	Units
Channel	Channel	1	See GroupAndChannels	-
Group	Group	1	26 (Z)	-
Reserved	Unsigned Short	2	0	-

TRANSCOMPLETE – Completes a Transferred Call

This command completes/concludes a transfer after the transfer has been initiated. **There is no query for this command.**

Command Form Details:

DEVICE **TRANSCOMPLETE** <Channel> <Group>

Argument	Type	Size	Values	Units
Channel	Channel	1	See GroupAndChannels	-
Group	Group	1	26 (Z)	-
Reserved	Unsigned Short	2	0	-

TRANSSTART – Initiate an Attended or Unattended Call Transfer

This command initiates a transfer of an established call to a new extension (defined by this command).

Command Form Details:

DEVICE **TRANSSTART** <Channel> <Group>[Value]

Argument	Type	Size	Values	Units
Channel	Channel	1	See GroupAndChannels	-
Group	Group	1	26 (Z)	-
Reserved	Unsigned Short	2	0	-
Value	String	44	1 – 44 Characters of '0' – '9', '*', '# and ',' (Null to query in text)	-

VE – VoIP Enable

This command selects (toggles) the hook status. This command is used to replace the XTE command for the Z group when VoIP multi-line is enabled. See MULTILNEN and MULTILNSTAT. State tracking is provided by the CALLSTATUS command

Command Form Details:

DEVICE **VE** <Channel> <Group>

Argument	Type	Size	Values	Units
Channel	Channel	1	See GroupAndChannels	-
Group	Group	1	26 (Z)	-
Reserved	Zero	2	Zero	-

SERIAL COMMAND SUPPORT TABLE

The following table shows serial command support by the CONVERGE/CONVERGE Pro and the Beamforming Microphone Array units by device type. Note that Telco-related commands only work on devices that have telephone interfaces (CONVERGE Pro 880TA, 880T, 840T, TH20); and AEC and NC-related commands do not work with CONVERGE SR 1212 and SR 1212A.

NOTE: None of the CONVERGE or Beamforming Microphone Array commands are used by the CONNECT CobraNet or CONNECT Dante units. Likewise, the commands used by the CONNECT units are not used by the CONVERGE and Beamforming Microphone Array units. Commands that start with "CNET" are for the CONNECT CobraNet, commands that start with "Dante" are for the Connect Dante units and are not included in this table.

COMMAND NAME	DEVICE									
	Pro 880	Pro 880T	Pro 840T	Pro 8i	Pro TH20	SR 1212	880TA	SR 1212A	Pro VH20	Beam-forming Mic Array
AA		X	X		X		X			
AAMB	X	X	X	X		X	X	X		
AARINGS		X	X		X		X			
ACONN		X	X		X		X			
ACONNLVL		X	X		X		X			
AD		X	X		X		X			
ADCLIP	X	X	X	X	X	X	X	X	X	
ADPRESENT	X	X	X	X	X	X	X	X	X	
AEC	X	X	X	X			X			
AGC	X	X	X	X	X	X	X	X	X	
AGCSET	X	X	X	X	X	X	X	X	X	
AMBLVL	X	X	X	X		X	X	X		
AMXDUET	X	X	X	X	X	X	X	X	X	
AV	X	X	X	X	X	X	X	X		
AVG							X	X		
AVR							X	X		
AVRT							X	X		
AVT							X	X		
AUDIOMASTER	X	X	X	X	X	X	X	X	X	
BAUD	X	X	X	X	X	X	X	X	X	
BFLED										X
BFMODE										X
BFMUTEMACRO										X
BFZONE										X
CALLDUR		X	X		X		X			
CALLERID		X	X		X		X			
CALLSTATUS									X	
CGROUP	X	X	X	X		X	X	X		
CHAIRO	X	X	X	X		X	X	X		
CLEARFFECT		X	X		X		X			
CLOCK	X	X	X	X	X	X	X	X	X	
COMPDLY							X	X		
COMPDLYEN							X	X		
COMPRESS	X	X	X	X		X	X	X		
COMPSEL	X	X	X	X		X	X	X		

COMMAND NAME	DEVICE									
	Pro 880	Pro 880T	Pro 840T	Pro 8i	Pro TH20	SR 1212	880TA	SR 1212A	Pro VH20	Beam-forming Mic Array
CONFCANCEL									X	
CONFCOMPLETE									X	
CONFSTART									X	
COUNTRY		X	X		X		X	X		
CTRLMASTER	X	X	X	X	X	X	X	X	X	
DECAY	X	X	X	X		X	X	X		
DEFAULT	X	X	X	X	X	X	X	X	X	X
DELAY	X	X	X	X		X	X	X		
DELAYSSEL	X	X	X	X		X	X	X		
DEVICENAME	X	X	X	X	X	X	X	X	X	
DEVICESUBTYPE	X	X	X	X	X	X	X	X	X	
DEVICETYPE	X	X	X	X	X	X	X	X	X	
DFLTM	X	X	X	X	X	X			X	
DIAG							X	X		
DIAL		X	X		X		X	X		
DID	X	X	X	X	X	X	X	X	X	X
DTMFLVL		X	X		X		X			
DTONELVL		X	X		X		X			
DUPDATE	X	X	X	X	X	X	X	X		
DVER	X	X	X	X	X	X	X	X	X	X
ENETADDR	X	X	X	X	X	X	X	X	X	
ENETHCP	X	X	X	X	X	X	X	X	X	
ENETDNS	X	X	X	X	X	X	X	X	X	
ENETDNSA	X	X	X	X	X	X	X	X	X	
ENETDNSA2	X	X	X	X	X	X	X	X	X	
ENETDOMAIN	X	X	X	X	X	X	X	X	X	
ENETGATE	X	X	X	X	X	X	X	X	X	
ENETQOSVAL									X	
ENETQOSDSCP									X	
ENETSUBN	X	X	X	X	X	X	X	X	X	
ENETVLAN									X	
ENETVLANID									X	
ENETVLANPRI									X	
EREF	X	X	X		X	X	X	X	X	X
EVENT	X	X	X	X	X	X	X	X	X	
FE							X	X		
FEB							X	X		
FEDR							X	X		
FEF							X	X		
FEG							X	X		
FEGL							X	X		
FELD							X	X		
FEM							X	X		
FEN							X	X		
FER							X	X		

COMMAND NAME	DEVICE									
	Pro 880	Pro 880T	Pro 840T	Pro 8i	Pro TH20	SR 1212	880TA	SR 1212A	Pro VH20	Beam-forming Mic Array
FERNG							X	X		
FES							X	X		
FESC							X	X		
FILTER	X	X	X		X	X	X	X		X
FILTSEL	X	X	X	X	X	X	X	X		X
FLOW	X	X	X	X	X	X	X	X	X	
FMP	X	X	X	X		X	X	X		
GAIN	X	X	X	X	X	X	X	X	X	X
GATE	X	X	X	X		X	X	X		X
GHOLD	X	X	X	X		X	X	X		
GMODE	X	X	X	X		X	X	X		
GOVER	X	X	X	X		X	X	X		
GPIOSTSTATUS	X	X	X	X	X	X	X	X	X	
GRATIO	X	X	X	X		X	X	X		
GREPORT	X	X	X	X	X	X	X	X	X	X
GRPSEL	X	X	X	X		X	X	X		
HDAEC										X
HDAECMODE										X
HDNLP	X	X		X	X		X			X
HDREFSEL1										X
HDREFSEL2										X
HOLD									X	
HOOK		X	X		X		X			
HOOKD		X	X		X		X			
LABEL	X	X	X	X	X	X	X	X	X	X
LCDCONTRAST	X	X	X	X	X	X	X	X	X	
LMO	X	X	X	X		X	X	X		X
LOCALNUM		X	X		X		X			
LOCBLDG	X	X	X	X	X	X	X	X	X	X
LOCCITY	X	X	X	X	X	X	X	X	X	X
LOCCNTRY	X	X	X	X	X	X	X	X	X	X
LOCCOMP	X	X	X	X	X	X	X	X	X	X
LOCREGION	X	X	X	X	X	X	X	X	X	X
LOCROOM	X	X	X	X	X	X	X	X	X	X
LOCSITENAME	X	X	X	X	X	X	X	X	X	
LOCSTATE	X	X	X	X	X	X	X	X	X	X
LOGMASK	X	X	X	X	X	X	X	X	X	
LVL	X	X	X	X	X	X	X	X	X	X
LVLREPORT	X	X	X	X	X	X	X	X	X	X
LVLREPORTEN	X	X	X	X	X	X	X	X	X	X
MACRO	X	X	X	X	X	X	X	X	X	
MANUFACTURER	X	X	X	X	X	X	X	X	X	
MAX	X	X	X	X	X	X	X	X	X	
MC							X	X		
MCGAIN							X	X		

COMMAND NAME	DEVICE									
	Pro 880	Pro 880T	Pro 840T	Pro 8i	Pro TH20	SR 1212	880TA	SR 1212A	Pro VH20	Beam-forming Mic Array
MCMINMAX							X	X		
MCMUTE							X	X		
MCRAMP							X	X		
MIN	X	X	X	X	X	X	X	X	X	X
MINMAX	X	X	X	X	X	X	X	X	X	X
MLINE	X	X	X	X		X	X	X		
MMAX	X	X	X	X		X	X	X		
MODEL	X	X	X	X	X	X	X	X	X	
MTRX	X	X	X	X	X	X	X	X	X	X
MTRXCLEAR	X	X	X	X	X	X	X	X	X	
MTRXLVL	X	X	X	X	X	X	X	X	X	
MTRXTYPE	X	X		X	X	X	X	X		
MULTILNEN									X	
MULTLNSTAT									X	
MUTE	X	X	X	X	X	X	X	X	X	X
NAME	X	X	X	X	X	X	X	X	X	X
NCD	X	X	X	X	X		X		X	X
NCSEL	X	X	X	X	X		X		X	X
NLP	X	X	X	X			X	X		
NOM	X	X	X		X	X	X	X	X	
NTPSRV	X	X	X	X	X	X	X	X	X	
NULL		X	X		X		X	X		
OFFA	X	X	X	X		X	X	X		
PAA	X	X	X	X		X	X	X		
PACEN							X	X		
PAENERGY							X	X		
PAEQEN							X	X		
PAEQRST							X	X		
PAEQSET							X	X		
PAFLT							X	X		
PAIMPED							X	X		
PALEN							X	X		
PALT							X	X		
PANGAT							X	X		
PANGEN							X	X		
PANGF							X	X		
PANGM							X	X		
PANGT							X	X		
PAPOL							X	X		
PARST							X	X		
PASME							X	X		
PASML							X	X		
PASSM							X	X		
PASMT							X	X		
PATO							X	X		

COMMAND NAME	DEVICE									
	Pro 880	Pro 880T	Pro 840T	Pro 8i	Pro TH20	SR 1212	880TA	SR 1212A	Pro VH20	Beam-forming Mic Array
PBDIAL		X	X		X		X		X	
PHONEBOOKADD		X	X		X		X		X	
PHONEBOOKCNT		X	X		X		X		X	
PHONEBOOKDEL		X	X		X		X		X	
PHONEBOOKREAD		X	X		X		X		X	
PP	X	X	X	X		X	X	X		
PRESET	X	X	X	X	X	X	X	X	X	
PRGSTRING	X	X	X	X	X	X	X	X	X	
PROXYSTAT									X	
PTTHRESHOLD	X	X	X	X			X	X		
PUSHTOTALK	X	X	X	X			X	X		
RAMP	X	X	X	X	X	X	X	X	X	X
REDIAL		X	X		X		X	X		
REFSEL	X	X	X	X		X	X	X		
REFSET	X	X	X	X		X	X	X	X	
RESET	X	X	X	X	X	X	X	X		X
RING		X	X		X		X			
RINGEREN		X	X		X		X			
RINGERLVL		X	X		X		X			
RINGERSEL		X	X		X		X			
RINGertest		X	X		X		X			
RINGMOD		X	X		X		X			
RINGOFF		X	X		X		X			
RINGON		X	X		X		X			
RXBOOST		X	X		X		X			
RXBSTEN		X	X		X		X			
SERECHO	X	X	X	X	X	X	X	X	X	X
SFTYMUTE	X	X	X	X	X	X	X	X	X	X
SIGGEN	X	X	X	X	X	X	X	X	X	
SIGGENEN	X	X	X	X	X	X	X	X	X	
SIGGENSWEEP	X	X	X	X	X	X	X	X	X	
SIGTOUT	X	X	X	X	X	X	X	X	X	
SLVL	X	X	X	X		X	X	X		
SMTPSRV	X	X	X	X	X	X	X	X	X	
SNMPMNGRIP	X	X	X	X	X	X	X	X	X	
SNMPMNGRPORT	X	X	X	X	X	X	X	X	X	
SNMPREADCOMM	X	X	X	X	X	X	X	X	X	
SNMPWRITECOMM	X	X	X	X	X	X	X	X	X	
SPEEDDIAL		X	X		X		X			
STRING	X	X	X	X	X	X	X	X		
SYSCHECKS	X	X	X	X	X	X	X	X	X	
SYSRESULT	X	X	X	X	X	X	X	X	X	
TAMODE		X	X		X		X			
TE		X	X		X		X			
TELCOLVCTRL		X	X		X		X			

COMMAND NAME	DEVICE									
	Pro 880	Pro 880T	Pro 840T	Pro 8i	Pro TH20	SR 1212	880TA	SR 1212A	Pro VH20	Beam-forming Mic Array
TELOVER		X	X		X		X			
TIMELOCALE	X	X	X	X	X	X	X	X	X	
TOUT	X	X	X	X	X	X	X	X	X	
TRANSCANCEL									X	
TRANSCOMPLETE									X	
TRANSSTART									X	
UID	X	X	X	X	X	X	X	X	X	X
VE									X	
VER	X	X	X	X	X	X	X	X	X	X
XAA		X	X		X		X		X	
XAAMB	X	X		X	X	X	X	X		X
XAARINGS		X	X		X		X		X	
XACONN		X	X		X		X		X	
XACONNLVL		X	X		X		X		X	
XACALLDUR		X	X		X		X		X	
XACALLERID		X	X		X		X		X	
XAMBLVL	X	X		X	X	X	X	X		X
XCALLDUR		X	X		X		X		X	
XCALLERID		X	X		X		X		X	
XCGROUP	X	X		X	X	X	X	X		
XCHAIR0	X	X		X	X	X	X	X		X
XCOMPRESS	X	X		X	X	X	X	X		
XCOMPSEL	X	X		X	X	X	X	X		
XDECAY	X	X		X	X	X	X	X		X
XDELAY	X	X		X	X	X	X	X		
XDELAYSEL	X	X		X	X	X	X	X		
XDIAL		X	X		X		X		X	
XDTMFLVL		X	X		X		X		X	
XDTONETLVL		X	X		X		X		X	
XGHOLD	X	X		X	X	X	X	X		X
XGMODE	X	X		X	X	X	X	X		X
XGOVER	X	X		X	X	X	X	X		X
XGRATIO	X	X		X	X	X	X	X		X
XGRPSEL	X	X		X	X	X	X	X		X
XHOOK		X	X		X		X		X	
XHOOKD		X	X		X		X		X	
XLOCALNUM		X	X		X		X		X	
XOFFA	X	X		X	X	X	X	X		X
XPBDIAL		X	X		X		X		X	
XREDIAL		X	X		X		X		X	
XRING		X	X		X		X		X	
XRINGEREN		X	X		X		X		X	
XRINGERLVL		X	X		X		X		X	
XRINGERSEL		X	X		X		X		X	

COMMAND NAME	DEVICE									
	Pro 880	Pro 880T	Pro 840T	Pro 8i	Pro TH20	SR 1212	880TA	SR 1212A	Pro VH20	Beam-forming Mic Array
XRINGERTEST		X	X		X		X		X	
XSLVL	X	X		X	X	X	X	X		X
XSPEEDDIAL		X	X		X		X		X	
XTE		X	X		X		X		X	
XTELCOLVCTRL		X	X		X		X		X	

ALL MODELS: RS-232 PORT CONNECTING WITH TELNET

Users can connect to any unit via RS-232 and telnet. Available telnet commands are the same as those used in the Serial Command section of this appendix.

How to Connect with Telnet:

- Use the telnet client of your choice
- Telnet uses port 23
- The user name and password are the same as used by Console. The default username is **clearone** and the default password is **converge**. These are not case sensitive.
- The telnet session will time out after 15 minutes of no receive data. A heart beat to keep the session alive will need to be used. ClearOne recommends using the VER command to establish a heart beat in order to keep the session alive.

ALL MODELS: RS-232 PORT

Pin #	User Definable	Control
1	N	DCD
2	N	TXD
3	N	RXD
4	N	DTR
5	N	Ground
6	N	DSR
7	N	CTS
8	N	RTS
9	N	No connection

NOTE: To avoid communication errors, ClearOne recommends using all nine pins when connecting to the RS-232 port.

APPENDIX B: DEFAULT PINOUTS

CONTROL/STATUS PORTS

CONVERGE Pro 880: Port A (Female DB-25)

Pin #	User Definable	Control/Status	Default Description
1	Y	Control (Input)	
2	Y	Status (Output)	
3	Y	Control (Input)	Mute All Mics Toggle
4	Y	Status (Output)	Status of Mute All Mics
5	Y	Control (Input)	Mute Output 9 Toggle
6	Y	Status (Output)	Status of Mute Output 9
7	Y	Control (Input)	Mute Output 10 Toggle
8	Y	Status (Output)	Status of Mute Output 10
9	Y	Control (Input)	Mute Output 11 Toggle
10	Y	Status (Output)	Status of Mute Output 11
11	Y	Control (Input)	Mute Output 12 Toggle
12	Y	Status (Output)	Status of Mute Output 12
13	Y	Control (Input)	Volume Up Output 1 (1 dB)
14	Y	Status (Output)	
15	Y	Control (Input)	Volume Down Output 1 (1 dB)
16	Y	Status (Output)	
17	N	Status (Output)	Microphone 1 Gate Status
18	N	Status (Output)	Microphone 2 Gate Status
19	N	Status (Output)	Microphone 3 Gate Status
20	N	Status (Output)	Microphone 4 Gate Status
21	N	Status (Output)	Microphone 5 Gate Status
22	N	Status (Output)	Microphone 6 Gate Status
23	N	Status (Output)	Microphone 7 Gate Status
24	N	Status (Output)	Microphone 8 Gate Status
25	NA	NA	Ground

CONVERGE Pro 880T: Port A (Female DB-25)

Pin #	User Definable	Control/Status	Default Description
1	Y	Control (Input)	
2	Y	Status (Output)	
3	Y	Control (Input)	Mute All Mics Toggle
4	Y	Status (Output)	Status of Mute All Mics
5	Y	Control (Input)	Mute Output 9 Toggle
6	Y	Status (Output)	Status of Mute Output 9
7	Y	Control (Input)	Mute Output 10 Toggle
8	Y	Status (Output)	Status of Mute Output 10
9	Y	Control (Input)	Mute Output 11 Toggle
10	Y	Status (Output)	Status of Mute Output 11
11	Y	Control (Input)	Mute Output 12 Toggle
12	Y	Status (Output)	Status of Mute Output 12
13	Y	Control (Input)	Toggle Telco On/Off
14	Y	Status (Output)	Telco Toggle Status (On/Off)
15	Y	Control (Input)	
16	Y	Status (Output)	
17	N	Status (Output)	Microphone 1 Gate Status
18	N	Status (Output)	Microphone 2 Gate Status
19	N	Status (Output)	Microphone 3 Gate Status
20	N	Status (Output)	Microphone 4 Gate Status
21	N	Status (Output)	Microphone 5 Gate Status
22	N	Status (Output)	Microphone 6 Gate Status
23	N	Status (Output)	Microphone 7 Gate Status
24	N	Status (Output)	Microphone 8 Gate Status
25	NA	NA	Ground

CONVERGE Pro 840T: Port A (Female DB-25)

Pin #	User Definable	Control/Status	Default Description
1	Y	Control (Input)	
2	Y	Status (Output)	
3	Y	Control (Input)	Mute All Mics Toggle
4	Y	Status (Output)	Status of Mute All Mics
5	Y	Control (Input)	Telco On/Off Toggle
6	Y	Status (Output)	Status of Telco On/Off
7	Y	Control (Input)	Auto Answer Toggle
8	Y	Status (Output)	Status of Auto Answer
9	Y	Control (Input)	Mute Output 5 Toggle
10	Y	Status (Output)	Status of Mute Output 5
11	Y	Control (Input)	Mute Input 5 Toggle
12	Y	Status (Output)	Status of Mute Input 5
13	Y	Control (Input)	Volume Up Output 8 (1 dB)
14	Y	Status (Output)	
15	Y	Control (Input)	Volume Down Output 8 (1 dB)
16	Y	Status (Output)	
17	N	Status (Output)	Microphone 1 Gate Status
18	N	Status (Output)	Microphone 2 Gate Status
19	N	Status (Output)	Microphone 3 Gate Status
20	N	Status (Output)	Microphone 4 Gate Status
21	Y	Status (Output)	
22	Y	Status (Output)	
23	Y	Status (Output)	
24	Y	Status (Output)	Ring Indication
25	NA	NA	Ground

CONVERGE Pro 8i: Port A (Female DB-25)

Pin #	User Definable	Control/Status	Default Description
1	Y	Control (Input)	
2	Y	Status (Output)	
3	Y	Control (Input)	Mute All Mics Toggle
4	Y	Status (Output)	Status of Mute All Mics
5	Y	Control (Input)	Mute Mic 1 Toggle
6	Y	Status (Output)	Status of Mute Mic 1
7	Y	Control (Input)	Mute Mic 2 Toggle
8	Y	Status (Output)	Status of Mute Mic 2
9	Y	Control (Input)	Mute Mic 3 Toggle
10	Y	Status (Output)	Status of Mute Mic 3
11	Y	Control (Input)	Mute Mic 4 Toggle
12	Y	Status (Output)	Status of Mute Mic 4
13	Y	Control (Input)	Mute Mic 5 Toggle
14	Y	Status (Output)	Status of Mute Mic 5
15	Y	Control (Input)	Mute Mic 6 Toggle
16	Y	Status (Output)	Status of Mute Mic 6
17	N	Status (Output)	Microphone 1 Gate Status
18	N	Status (Output)	Microphone 2 Gate Status
19	N	Status (Output)	Microphone 3 Gate Status
20	N	Status (Output)	Microphone 4 Gate Status
21	N	Status (Output)	Microphone 5 Gate Status
22	N	Status (Output)	Microphone 6 Gate Status
23	N	Status (Output)	Microphone 7 Gate Status
24	N	Status (Output)	Microphone 8 Gate Status
25	NA	NA	Ground

CONVERGE Pro TH20: Port A (Female DB-25)

Pin #	User Definable	Control/Status	Default Description
1	Y	Control (Input)	Telco On
2	Y	Status (Output)	Telco On Indicator
3	Y	Control (Input)	Telco Off
4	Y	Status (Output)	Telco off indicator
5	Y	Control (Input)	
6	Y	Status (Output)	
7	Y	Control (Input)	
8	Y	Status (Output)	
9	Y	Control (Input)	Transmit Mute
10	Y	Status (Output)	Transmit Mute status
11	Y	Control (Input)	Receive Mute
12	Y	Status (Output)	Receive mute status
13	Y	Control (Input)	
14	Y	Status (Output)	
15	Y	Control (Input)	
16	Y	Status (Output)	
17	Y	Status (Output)	
18	Y	Status (Output)	
19	Y	Status (Output)	
20	Y	Status (Output)	
21	Y	Status (Output)	
22	Y	Status (Output)	
23	Y	Status (Output)	
24	Y	Status (Output)	Ring Indication
25	NA	NA	Ground

CONVERGE Pro VH20: Port A (Female DB-25)

Pin #	User Definable	Control/Status	Default Description
1	Y	Control (Input)	Telco On
2	Y	Status (Output)	Telco On Indicator
3	Y	Control (Input)	Telco Off
4	Y	Status (Output)	Telco off indicator
5	Y	Control (Input)	
6	Y	Status (Output)	
7	Y	Control (Input)	
8	Y	Status (Output)	
9	Y	Control (Input)	Transmit Mute
10	Y	Status (Output)	Transmit Mute status
11	Y	Control (Input)	Receive Mute
12	Y	Status (Output)	Receive mute status
13	Y	Control (Input)	
14	Y	Status (Output)	
15	Y	Control (Input)	
16	Y	Status (Output)	
17	Y	Status (Output)	
18	Y	Status (Output)	
19	Y	Status (Output)	
20	Y	Status (Output)	
21	Y	Status (Output)	
22	Y	Status (Output)	
23	Y	Status (Output)	
24	Y	Status (Output)	Ring Indication
25	NA	NA	Ground

CONVERGE SR 1212: Port A (Female DB-25)

Pin #	User Definable	Control/Status	Default Description
1	Y	Control (Input)	
2	Y	Status (Output)	
3	Y	Control (Input)	Mute All Mics Toggle
4	Y	Status (Output)	Status of Mute All Mics
5	Y	Control (Input)	Mute Output 9 Toggle
6	Y	Status (Output)	Status of Mute Output 9
7	Y	Control (Input)	Mute Output 10 Toggle
8	Y	Status (Output)	Status of Mute Output 10
9	Y	Control (Input)	Mute Output 11 Toggle
10	Y	Status (Output)	Status of Mute Output 11
11	Y	Control (Input)	Mute Output 12 Toggle
12	Y	Status (Output)	Status of Mute Output 12
13	Y	Control (Input)	Volume Up Output 1 (1 dB)
14	Y	Status (Output)	
15	Y	Control (Input)	Volume Down Output 1 (1 dB)
16	Y	Status (Output)	
17	N	Status (Output)	Microphone 1 Gate Status
18	N	Status (Output)	Microphone 2 Gate Status
19	N	Status (Output)	Microphone 3 Gate Status
20	N	Status (Output)	Microphone 4 Gate Status
21	N	Status (Output)	Microphone 5 Gate Status
22	N	Status (Output)	Microphone 6 Gate Status
23	N	Status (Output)	Microphone 7 Gate Status
24	N	Status (Output)	Microphone 8 Gate Status
25	NA	NA	Ground

All Models: Port B (Female DB-25)

Pin #	User Definable	Control/Status	Default Description
1	N	Control (Input)	Preset Mask Bit 0
2	N	Status (Output)	Preset Indicator Bit 0
3	N	Control (Input)	Preset Mask Bit 1
4	N	Status (Output)	Preset Indicator Bit 1
5	N	Control (Input)	Preset Mask Bit 2
6	N	Status (Output)	Preset Indicator Bit 2
7	N	Control (Input)	Preset Mask Bit 3
8	N	Status (Output)	Preset Indicator Bit 3
9	N	Control (Input)	Preset Mask Bit 4
10	N	Status (Output)	Preset Indicator Bit 4
11	N	Control (Input)	Preset Mask Bit 5
12	N	Status (Output)	Preset Indicator Bit 5
13	N	Control (Input)	Preset Mask Bit 6
14	N	Status (Output)	Preset Indicator Bit 6
15	N	Control (Input)	Preset Mask Bit 7
16	N	Status (Output)	Preset Indicator Bit 7
17	N	Control (Input)	Preset Mask Bit 8
18	N	Status (Output)	Preset Indicator Bit 8
19	N	Control (Input)	Preset Mask Bit 9
20	N	Status (Output)	Preset Indicator Bit 9
21	Y	Control (Input)	
22	Y	Status (Output)	
23	NA	NA	+3.3V 300 mA
24	NA	NA	+3.3V 300 mA
25	NA	NA	Ground

ALL MODELS: RS-232 PORT

Pin #	User Definable	Control
1	N	DCD
2	N	TXD
3	N	RXD
4	N	DTR
5	N	Ground
6	N	DSR
7	N	CTS
8	N	RTS
9	N	No connection

NOTE: To avoid communication errors, ClearOne recommends using all nine pins when connecting to the RS-232 port.

APPENDIX C: FIRMWARE LOADING PROCEDURE

The 4.X versions of CONVERGE Console offer significant upgrades from previous versions. ClearOne strongly encourages users to upgrade all firmware to the latest release version.

NOTE: Before performing any firmware upgrade save the CONVERGE Console site file.

NOTE: When connecting to a CONVERGE Pro site, CONVERGE Console checks for firmware/software compatibility. If a compatibility issue is found the firmware uploader screen will be presented to update the firmware. Follow the steps below to update the firmware. If you choose not to perform the firmware update, close CONVERGE Console and use CONVERGE Manager to select the version of CONVERGE Console that is compatible with the firmware in the CONVERGE Pro.

If the connected Site contains units that are Version 3.X, they must be removed from the expansion bus prior to performing the firmware upgrade.

Please follow the steps below to upgrade your Firmware:

Upgrading from 1.X Firmware Steps

1. Remove any 2.X, 3.X and 4.X units from the stack by disconnecting the expansion bus link cable from the 1.X units.
2. Re-connect to the 1.X stack with Console.
3. Download the 4.X firmware file to the stack of units.
4. The units will default and reboot after the download of 4.X firmware. The 1.X to 4.X upgrade requires the firmware to be loaded twice to complete the version upgrade.
5. Reconnect to the stack with Console. Download 4.X a second time to the units. The units will reboot.
6. Units are fully upgraded.
7. Verify units have been upgraded by check firmware version on the front panel.

Upgrading from 2.X Firmware Steps

1. Remove any 1.X, 3.X and 4.X units from the stack by disconnecting the expansion bus link cable from the 2.X units.
2. Re-connect to the 2.X stack with Console.
3. Download the 4.X firmware file to the stack of units.
4. The units will default and reboot after the download of 4.X firmware. The 2.X to 4.X upgrade requires the firmware to be loaded twice to complete the version upgrade.
5. Units are fully upgraded.
6. Verify units have been upgraded by check firmware version on the front panel.

Upgrading from 3.X Firmware Steps

1. Remove any 1.X, 2.X and 4.X units from the stack by disconnecting the expansion bus link cable from the 3.X units.
2. Re-connect to the 3.X stack with Console.
3. Download the 4.X firmware file to the stack of units.
4. The units will default and reboot after the download of 4.X firmware.
5. Units are fully upgraded.
6. Verify units have been upgraded by check firmware version on the front panel.

The units have been upgraded. Reconnect all expansion bus cables, if needed, to complete the stack of units.

Upgrading the Beamforming Microphone Array

1. All CONVERGE Pro units in the site must be running firmware 4.X to be compatible with the Beamforming Microphone Array. Follow the appropriate procedure above to update the firmware on the CONVERGE Pro units.
2. Connect the expansion bus cable between the CONVERGE Pro unit and the Beamforming Microphone Array.
3. Connect the CONVERGE Pro units with CONVERGE Console.
4. Open the firmware uploader screen.
5. Browse for the bf_mic.mdo file.
6. Download the Beamforming Microphone Array firmware.
7. The Beamforming Microphone Array(s) will default and reboot after the download of 4.X firmware.
8. Units are fully upgraded.

APPENDIX D: SPECIFICATIONS

CONVERGE PRO 880

Audio Performance

- Conditions: Unless otherwise specified, all measurements are performed with a 20 Hz to 22 kHz BW limit (no weighting)
- Frequency Response: 20 Hz to 22 kHz \pm 1 dB
- Noise (EIN): -126 dBu, 22 kHz BW, max gain, Rs= 150 Ω
- THD+N: <0.02%
- Dynamic Range: >100 dB (non A-weighted)
- Crosstalk <-91 dB re 20 dBu @ 20 kHz channel to channel
 - » Low Pass
 - » High Pass
 - » Notch
 - » PEQ
- Mute on/off
- Chairman Override on/off
- AGC on/off
- Automatic Level Control on/off
- Auto Gate/Manual gate
- Adaptive Ambient on/off
- Pre AEC channel

Auto Mixer Features

- Number of Open Microphones (NOM)
- PA Adaptive Mode
- First Mic Priority Mode
- Last Mic Mode
- Maximum # of Mics Mode
- Ambient Level
- Gate Threshold Adjust
- Off Attenuation Adjust
- Hold Time
- Decay Rate

Matrix Mixing Features

- 36x36 matrix
- 12 analog in/out
- 12 expansion bus in/out
- 8 assignable processing blocks in/out
- 4 assignable fader blocks in/out

Assignable Processing Blocks

- Filters
 - » All pass
 - » Low pass
 - » High pass
 - » Low shelving
 - » High shelving
 - » Parametric EQ
 - » Notch
 - » CD Horn
- Crossovers
 - » Bessel
 - » Butterworth
 - » Linkwitz-Riley
- Compressor
- Delay; adjustable up to 250 ms

Assignable Fader Blocks

- Gain/Mute

Microphone Input Configuration

- Input Gain Adjust
- Mic or Line Level
- Phantom Power on/off
- Echo Cancellation on/off
- Noise Cancellation on/off
- Filters
 - » All Pass

Mic/Line Inputs 1-8

- Push-on mini-terminal block, balanced, bridging
- Impedance: < 10 K Ω
- Nominal Level: adjustable -56 dBu to 0 dBu (7 dB step coarse gain adjustment)
- Maximum Level: -65 dBu to +20 dBu
- Echo Cancellation: 130 ms tail time (works with 12 dB of room gain)
- Noise Cancellation: 6–15 dB attenuation
- Phantom Power: 24 V, selectable

Line Inputs 9-12

- Push-on mini-terminal block, balanced, bridging
- Impedance: < 10 K Ω
- Nominal Level: 0 dBu
- Maximum Level: 20 dBu

Outputs 1-12

- Push-on mini-terminal block, balanced
- Impedance: < 50 Ω
- Nominal Level: 0 dBu
- Maximum Level: 20 dBu

Expansion Bus In/Out

- Proprietary Network
- RJ-45 (2), 1.9 Mbps
- CAT-5 twisted-pair cable, 200' maximum cable length

Ethernet

- Autoswitching with Quality of Connection (QoC)
- 10/100 Mbps Ethernet Network Port
- 10/100 Mbps Ethernet PC Port
- RJ-45 Connectors

RS-232

- Serial Command Protocol Only (Console software not supported on RS-232 port)
- DB-9 female
- 9,600/19,200/38,400/57,600/115,200 baud rate; 8 bits, 1 stop bit, no parity
- Hardware flow control on (default)/off

USB

- Version 2.0 compatible
- Type: B-connector

CONVERGE PRO 880 (continued)

Control/Status Ports

- DB-25 female A/B (2)
- Inputs A/B: active low (pull to ground)
- Outputs A/B: open collector, 40 VDC max, 40 mA each
- +3.3 VDC pins (2) (300 mA over-current protected)

Configuration & Administration Software

- CONVERGE® Console

Power Input Range

- Auto-Adjusting
- 100–240 VAC; 50/60 Hz

Power Consumption

- 30 W Typical

Dimensions (L x D x H)

- 17.25" x 10.25" x 1.75"
- 43.8 x 26 x 4.5 cm

Weight

- 7.5 lbs/3.3375 kg unit weight
- 12 lbs/5.4kg shipping weight

Operating Temperature

- 14° F/-10° C to 122° F/50° C ambient unit temperature

Approvals

- See *Appendix D: Compliance*
- AES48-2005: AES standard on interconnections — Grounding and EMC practices — Shields of connectors in audio equipment containing active circuitry (self certified)

Part Number

910-151-880 Converge Pro 880
8-Channel AEC Microphone Mixer

CONVERGE PRO 880T

Audio Performance

- Conditions: Unless otherwise specified, all measurements are performed with a 20 Hz to 22 kHz BW limit (no weighting)
- Frequency Response: 20 Hz to 22 kHz \pm 1 dB
- Noise (EIN): -126 dBu, 22 kHz BW, max gain,
- $R_s = 150 \Omega$
- THD+N: < 0.02%
- Dynamic Range: > 100 dB (non A-weighted)
- Crosstalk < -91 dB re 20 dBu @ 20 kHz channel to channel

Auto Mixer Features

- Number of Open Microphones (NOM)
- PA Adaptive Mode
- First Mic Priority Mode
- Last Mic Mode
- Maximum # of Mics Mode
- Ambient Level
- Gate Threshold Adjust
- Off Attenuation Adjust
- Hold Time
- Decay Rate

Matrix Mixing Features

- 37x38 matrix
- 12 analog in/out
- 12 expansion bus in/out
- 8 assignable processing blocks in/out
- 4 assignable fader blocks in/out
- 1 10W speaker amplifier
- 1 telco input/1 telco output

Assignable Processing Blocks

- Filters
 - » All pass
 - » Low pass
 - » High pass
 - » Low shelving
 - » High shelving
 - » Parametric EQ
 - » Notch
 - » CD Horn
- Crossovers
 - » Bessel
 - » Butterworth
 - » Linkwitz-Riley
- Compressor
- Delay; adjustable up to 250 ms

Assignable Fader Blocks

- Gain/Mute

Microphone Input Configuration

- Input Gain Adjust
- Mic or Line Level
- Phantom Power on/off
- Echo Cancellation on/off
- Noise Cancellation on/off
- Filters
 - » All Pass
 - » Low Pass
 - » High Pass
 - » Notch
 - » PEQ
- Mute on/off
- Chairman Override on/off

- AGC on/off
- Automatic Level Control on/off
- Auto Gate/Manual gate
- Adaptive Ambient on/off
- Pre AEC channel

Mic/Line Inputs 1-8

- Push-on mini-terminal block, balanced, bridging
- Impedance: < 10 K Ω
- Nominal Level: adjustable -56 dBu to 0 dBu (7 dB step coarse gain adjustment)
- Maximum Level: -65 dBu to +20 dBu
- Echo Cancellation: 130 ms tail time (works with 12 dB of room gain)
- Noise Cancellation: 6–15 dB attenuation
- Phantom Power: 24 V, selectable

Line Inputs 9-12

- Push-on mini-terminal block, balanced, bridging
- Impedance: < 10 K Ω
- vNominal Level: 0 dBu
- Maximum Level: 20 dBu

Outputs 1-12

- Push-on mini-terminal block, balanced
- Impedance: < 50 Ω
- Nominal Level: 0 dBu
- Maximum Level: 20 dBu

Amplifier Output

- Binding Post Connection
- 10 Watts @ 4 Ω Impedance
- THD + Noise: < 0.5%

Telco Line

- RJ-11
- POTS (plain old telephone service) or analog extension from a PBX
- A-lead supervision provided

Telco Set

- RJ-11
- POTS (plain old telephone service) or analog extension from a PBX
- A-lead supervision provided

Telephone Audio Performance

- Conditions: Unless otherwise specified, all measurements are performed with Transmit Limiter and Receive ALC disabled
- Frequency Response: 250Hz to 3.3 kHz \pm 1 dB
- THD+N: < 0.3% re-max level 250 Hz to 3.3 kHz
- SNR: > 62 dB re-max level

Telco Line Echo Cancellation

- Tail Time: 31 ms
- Null: 55 dB nominal

Telephone Noise Cancellation

- Noise Cancellation 6-15 dB attenuation

Expansion Bus In/Out

- Proprietary Network
- RJ-45 (2), 1.9 Mbps
- CAT-5 twisted-pair cable, 200' maximum cable length

CONVERGE PRO 880T (continued)

Ethernet

- Autoswitching with Quality of Connection (QoC)
- 10/100 Mbps Ethernet Network Port
- 10/100 Mbps Ethernet PC Port
- RJ-45 Connectors

RS-232

- Serial Command Protocol Only (Console software not supported on RS-232 port)
- DB-9 female
- 9,600/19,200/38,400/57,600/115,200 baud rate; 8 bits, 1 stop bit, no parity
- Hardware flow control on (default)/off

USB

- Version 2.0 compatible
- Type: B-connector

Control/Status Ports

- DB-25 female A/B (2)
- Inputs A/B: active low (pull to ground)
- Outputs A/B: open collector, 40 VDC max, 40 mA each
- +3.3 VDC pins (2) (300 mA over-current protected)

Configuration & Administration Software

- CONVERGE Console

Power Input Range

- Auto-Adjusting
- 100–240 VAC; 50/60 Hz

Power Consumption

- 30 W Typical

Dimensions (L x D x H)

- 17.25" x 10.25" x 1.75"
- 43.8 x 26 x 4.5 cm

Weight

- 7.5 lbs/3.3375 kg unit weight
- 12 lbs/5.4kg shipping weight

Operating Temperature

- 14° F/-10° C to 122° F/50° C ambient unit temperature

Approvals

- See *Appendix D: Compliance*
- AES48-2005: AES standard on interconnections — Grounding and EMC practices — Shields of connectors in audio equipment containing active circuitry (self certified)

Part Number

910-151-881 Converge Pro 880T
8-Channel AEC Microphone Mixer with Telephone Hybrid and
10W Amplifier

CONVERGE PRO 880TA

Audio Performance:

- Conditions: Unless otherwise specified, all measurements are performed from 20 HZ to 22 kHz BW limit (no weighting)
- Frequency Response: 20 Hz to 22kHz +- 1 dB
- Noise(EIN): -126 dBu, 20 kHz BW, max Gain
- Rs= 150 ohm
- THD+ Noise: <.02%
- Dynamic Range: >105 dB (non A weighted)
- Crosstalk: <91 db re 20dBu @ 20 kHz channel to channel.

Audio Mixer Parameters

- Number of Open Microphones
- PA Adaptive Mode
- First Mic Priority Mode
- Maximum # of Mics
- Ambient Level
- Gate Threshold Adjust
- Off Attenuation Adjust
- Hold Time
- Decay Rate
- Chairman Override
- 96 Total Microphones per site
- 6- Global Gating Groups

- 4- Internal Gating Groups

Matrix Mixing Parameters

- 8- Microphone Analog Inputs
- 4- Analog Line Inputs
- 8-Analog Line Outputs
- 4- Power Amplifier Outputs
- 18- Expansion Bus in/out

- 8- Processing Blocks

Assignable Processing Blocks

- Filters:
 - » All Pass
 - » Low Pass
 - » Low shelving
 - » High shelving
 - » PEQ
 - » Notch
 - » Crossovers
- Compressor
- Delay up to 250 msec

Power Amplifier Output Processing

- Feedback Elimination w/ ring cancellation
- 10-band EQ filter
- 4- node filter bank for crossover
- Delay Block
- Compressor/Limiter
- Noise Gate for Hiss Control
- Sound Masking Generator per channel
- Adaptive Volume Control
- Multi Channel Control

Microphone Processing

- 4-node filter bank
- AGC/.ALC

Power Amplifier

- Channels: 4
- Amplifier Output: 35-Watt into 8 ohm
- Impedence: Selectable 8ohm, 70V, 100 V
- THD+ Noise: <.2% (1/3 Power)
- Crosstalk: <-68dB

Telco Line Port

- RJ-11 POTS (plain old telephone service) or analog PBX extension
- A-lead supervision provided

Telco Set Port

- Pass-through RJ-11 analog jack

Telephone Audio Performance

Conditions: Unless otherwise specified, all measurements are performed with Transmit Limiter and

- Receive ALC disabled
- Frequency Response: 250Hz to 3.3 kHz \pm 1dB
- THD+N: <0.3% re-max level 250 Hz to 3.3 kHz
- SNR: > 62 dB re-max level

Telco Line Echo Cancellation

- Tail Time: 31ms
- Null: 55 dB nominal

Telephone Noise Cancellation

- Noise Cancellation 6-15 dB attenuation

Expansion Bus

- Connection: CAT 5, RJ45
- Mix Minus Structure
- 18 Audio Buses
- 6 Gating Buses
- 8 PA Reference Buses

Network

- 10/100 Auto Switching (PC and Network Port)
- HTTP Server
- Telnet Client
- SNMP Agent
- SNTP Client
- DNS
- DHCP

RS-232

- DB-9
- 9.6k – 115k baud
- 8/1/0
- Hardware Flow Control

USB

- 2.0 Compatible
- Type B connector

GPIO

- DB 25 female (A/B)
- Inputs: Active Low
- Outputs: Open Collector, 40Vdc, 40 mA

Power

- 100-240VAC; 50/60 Hz,
- 300 Watts (maximum)

Environmental

- Operating temperature:
- 32-122 degrees F

Humidity:

- 15 to 80%

Mechanical

- Dimensions: 2RU
- 3.5" H x 17.25" W x 15.92" D
- Weight: < 30 lbs.

Compliance

- EMC- FCC Part 15 Class A
- EMI – EN55024
- Safety - IEC60950, CSA, CCC
- Class 2 Wiring Required

CONVERGE PRO 840T

Audio Performance

- Conditions: Unless otherwise specified, all measurements are performed with a 20 Hz to 22 kHz BW limit (no weighting)
- Frequency Response: 20 Hz to 22 kHz ± 1 dB
- Noise (EIN): -126 dBu, 20 kHz BW, max gain,
- $R_s = 150 \Omega$
- THD+N: $< 0.02\%$
- Dynamic Range: > 100 dB (non A-weighted)
- Crosstalk < -91 dB re 20 dBu @ 20 kHz channel to channel

Auto Mixer Features

- Number of Open Microphones (NOM)
- PA Adaptive Mode
- First Mic Priority Mode
- Last Mic Mode
- Maximum # of Mics Mode
- Ambient Level
- Gate Threshold Adjust
- Off Attenuation Adjust
- Hold Time
- Decay Rate

Matrix Mixing Features

- 29x30 matrix
- 8 analog in/out
- 1 speaker out (amplified)
- 12 expansion bus in/out
- 4 assignable processing blocks in/out
- 4 assignable fader blocks in/out
- 1 telco in/out

Assignable Processing Blocks

- Filters
 - » All pass
 - » Low pass
 - » High pass
 - » Low shelving
 - » High shelving
 - » Parametric EQ
 - » Notch
 - » CD Horn
- Crossovers
 - » Bessel
 - » Butterworth
 - » Linkwitz-Riley
- Compressor
- Delay; adjustable up to 250 ms

Assignable Fader Blocks

- Gain/Mute

Microphone Input Configuration

- Input Gain Adjust
- Mic or Line Level
- Phantom Power on/off
- Echo Cancellation on/off
- Noise Cancellation on/off
- Filters
 - » All Pass
 - » Low Pass
 - » High Pass
 - » Notch
 - » PEQ
- Mute on/off
- Chairman Override on/off

- AGC on/off
- Automatic Level Control on/off
- Auto Gate/Manual gate
- Adaptive Ambient on/off
- Pre AEC channel

Mic/Line Inputs 1-4

- Push-on mini-terminal block, balanced, bridging
- Impedance: $< 10 K\Omega$
- Nominal Level: adjustable -56 dBu to 0 dBu (7 dB step coarse gain adjustment)
- Maximum Level: -65 dBu to +20 dBu
- Echo Cancellation: 130 ms tail time (works with 12 dB of room gain)
- Noise Cancellation: 6–15 dB attenuation
- Phantom Power: 24 V, selectable

Line Inputs 5-8

- Push-on mini-terminal block, balanced, bridging
- Impedance: $< 10 K\Omega$
- Nominal Level: 0 dBu
- Maximum Level: 20 dBu

Outputs 1-8

- Push-on mini-terminal block, balanced
- Impedance: $< 50 \Omega$
- Nominal Level: 0 dBu
- Maximum Level: 20 dBu

Amplifier Output

- Binding Post Connection
- 10 Watts @ 4 Ω Impedance
- THD + Noise: $< 0.5\%$

Telco Line

- RJ-11
- POTS (plain old telephone service) or analog extension from a PBX
- A-lead supervision provided

Telco Set

- RJ-11
- POTS (plain old telephone service) or analog extension from a PBX
- A-lead supervision provided

Telephone Audio Performance

- Conditions: Unless otherwise specified, all measurements are performed with Transmit Limiter and Receive ALC disabled
- Frequency Response: 250Hz to 3.3 kHz ± 1 dB
- THD+N: $< 0.3\%$ re-max level 250 Hz to 3.3 kHz
- SNR: > 62 dB re-max level

Telco Line Echo Cancellation

- Tail Time: 31 ms
- Null: 55 dB nominal

Telephone Noise Cancellation

- Noise Cancellation 6-15 dB attenuation

Expansion Bus In/Out

- Proprietary Network
- RJ-45 (2), 1.9 Mbps
- CAT-5 twisted-pair cable, 200' maximum cable length

CONVERGE PRO 840T (continued)

Ethernet

- Autoswitching with Quality of Connection (QoC)
- 10/100 Mbps Ethernet Network Port
- 10/100 Mbps Ethernet PC Port
- RJ-45 Connectors

RS-232

- Serial Command Protocol Only (Console software not supported on RS-232 port)
- DB-9 female
- 9,600/19,200/38,400/57,600/115,200 baud rate; 8 bits, 1 stop bit, no parity
- Hardware flow control on (default)/off

USB

- Version 2.0 compatible
- Type: B-connector

Control/Status Ports

- DB-25 female A/B (2)
- Inputs A/B: active low (pull to ground)
- Outputs A/B: open collector, 40 VDC max, 40 mA each
- +3.3 VDC pins (2) (300 mA over-current protected)

Configuration & Administration Software

- CONVERGE Console

Power Input Range

- Auto-Adjusting
- 100–240 VAC; 50/60 Hz

Power Consumption

- 30 W Typical

Dimensions (L x D x H)

- 17.25" x 10.25" x 1.75"
- 43.8 x 26 x 4.5 cm

Weight

- 7.5 lbs/3.3375 kg unit weight
- 12 lbs/5.4kg shipping weight

Operating Temperature

- 14° F/-10° C to 122° F/50° C ambient unit temperature

Approvals

- See *Appendix D: Compliance*
- AES48-2005: AES standard on interconnections — Grounding and EMC practices — Shields of connectors in audio equipment containing active circuitry (self certified)

Part Number

910-151-840 Converge Pro 840T
4-Channel AEC Microphone Mixer with Telephone Hybrid and
10W Amplifier

CONVERGE PRO 8I

Audio Performance

- Conditions: Unless otherwise specified, all measurements are performed with a 20 Hz to 22 kHz BW limit (no weighting)
- Frequency Response: 20 Hz to 22 kHz \pm 1 dB
- Noise (EIN): -126 dBu, 20 kHz BW, max gain,
- $R_s = 150 \Omega$
- THD+N: < 0.02%
- Dynamic Range: > 100 dB (non A-weighted)
- Crosstalk < -91 dB re 20 dBu @ 20 kHz channel to channel

Auto Mixer Features

- Number of Open Microphones (NOM)
- PA Adaptive Mode
- First Mic Priority Mode
- Last Mic Mode
- Maximum # of Mics Mode
- Ambient Level
- Gate Threshold Adjust
- Off Attenuation Adjust
- Hold Time
- Decay Rate

Matrix Mixing Features

- 36x24 matrix
- 12 analog in/out
- 12 expansion bus in/out
- 8 assignable processing blocks in/out
- 4 assignable fader blocks in/out

Assignable Processing Blocks

- Filters
 - » All pass
 - » Low pass
 - » High pass
 - » Low shelving
 - » High shelving
 - » Parametric EQ
 - » Notch
 - » CD Horn
- Crossovers
 - » Bessel
 - » Butterworth
 - » Linkwitz-Riley
- Compressor
- Delay; adjustable up to 250 ms

Assignable Fader Blocks

- Gain/Mute

Microphone Input Configuration

- Input Gain Adjust
- Mic or Line Level
- Phantom Power on/off
- Echo Cancellation on/off
- Noise Cancellation on/off
- Filters
 - » All Pass
 - » Low Pass
 - » High Pass
 - » Notch
 - » PEQ
- Mute on/off
- Chairman Override on/off
- AGC on/off
- Automatic Level Control on/off

- Auto Gate/Manual gate
- Adaptive Ambient on/off
- Pre AEC channel

Mic/Line Inputs 1-8

- Push-on mini-terminal block, balanced, bridging
- Impedance: < 10 K Ω
- Nominal Level: adjustable -56 dBu to 0 dBu (7 dB step coarse gain adjustment)
- Maximum Level: -65 dBu to +20 dBu
- Echo Cancellation: 130 ms tail time (works with 12 dB of room gain)
- Noise Cancellation: 6–15 dB attenuation
- Phantom Power: 24 V, selectable

Line Inputs 9-12

- Push-on mini-terminal block, balanced, bridging
- Impedance: < 10 K Ω
- Nominal Level: 0 dBu
- Maximum Level: 20 dBu

Expansion Bus In/Out

- Proprietary Network
- RJ-45 (2), 1.9 Mbps
- CAT-5 twisted-pair cable, 200' maximum cable length

Ethernet

- Autoswitching with Quality of Connection (QoC)
- 10/100 Mbps Ethernet Network Port
- 10/100 Mbps Ethernet PC Port
- RJ-45 Connectors

RS-232

- Serial Command Protocol Only (Console software not supported on RS-232 port)
- DB-9 female
- 9,600/19,200/38,400/57,600/115,200 baud rate; 8 bits, 1 stop bit, no parity
- Hardware flow control on (default)/off

USB

- Version 2.0 compatible
- Type B connector

Control/Status Ports

- DB-25 female A/B (2)
- Inputs A/B: active low (pull to ground)
- Outputs A/B: open collector, 40 VDC max, 40 mA each
- +3.3 VDC pins (2) (300 mA over-current protected)

Configuration & Administration Software

- Converge Console

Power Input Range

- Auto-Adjusting
- 100–240 VAC; 50/60 Hz

Power Consumption

- 30 W Typical

Dimensions (L x D x H)

- 17.25" x 10.25" x 1.75"
- 43.8 x 26 x 4.5 cm

CONVERGE PRO 8I (CONTINUED)

Weight

- 7.5 lbs/3.3375 kg unit weight
- 12 lbs/5.4 kg shipping weight

Operating Temperature

- 14° F/-10° C to 122° F/50° C ambient unit temperature

Approvals

- See *Appendix D: Compliance*
- AES48-2005: AES standard on interconnections — Grounding and EMC practices — Shields of connectors in audio equipment containing active circuitry (self certified)

Part Number

910-151-810 Converge Pro 8i
8-Channel AEC Microphone Mixer (no outputs)

CONVERGE PRO TH20

Telephone Audio Performance

- Conditions: Unless otherwise specified, all measurements are performed with Transmit Limiter and Receive ALC disabled
- Frequency Response: 250Hz to 3.3 kHz \pm 1dB
- THD+N: <0.3% re-max level 250 Hz to 3.3 kHz
- SNR: > 62 dB re-max level

Telephone Noise Cancellation

- Noise Cancellation 6-15 dB attenuation

Telco Line Echo Cancellation

- Tail Time: 31 ms
- Null: 55 dB nominal

Telco Line

- RJ-11
- POTS (plain old telephone service) or analog extension from a PBX)
- A-lead supervision provided

Telco Set

- RJ-11
- POTS (plain old telephone service) or analog extension from a PBX
- A-lead supervision provided

Audio Performance

- Conditions: Unless otherwise specified, all measurements are performed with a 20 Hz to 22 kHz BW limit (no weighting)
- Frequency Response: 20 Hz to 22 kHz \pm 1dB
- $R_s=150 \Omega$
- THD+N: <0.02%
- Dynamic Range: 100 dB (non A-weighted)
- Crosstalk <-91 dB re 20 dBu @ 20 kHz channel to channel

Line Inputs 1, 2

- Push-on mini-terminal block, balanced, bridging
- Impedance: < 10 K Ω
- Nominal Level: 0 dBu
- Maximum Level: 20 dBu

Line Outputs 1,2

- Push-on mini-terminal block, balanced
- Impedance: < 50 k Ω
- Nominal Level: 0 dBu
- Maximum Level: 20 dBu

Expansion Bus In/Out

- Proprietary Network
- RJ-45 (2), 1.9 Mbps
- Category 5 twisted-pair cable, 200' maximum cable length between any two CONVERGE/CONVERGE Pro devices

Ethernet

- Autoswitching with Quality of Connection (QoC)
- 10/100 Mbps Ethernet Network Port
- 10/100 Mbps Ethernet PC Port
- RJ-45 Connectors

RS-232

- Serial Command Protocol Only (Console software not supported on RS-232 port)
- DB-9 female
- 9,600/19,200/38,400/57,600/115,200 baud rate; 8 bits, 1 stop bit, no parity
- Hardware flow control on (default)/off

USB

- Version 2.0 compatible
- Type: B-connector

Control/Status Ports

- DB-25 female A/B (2)
- Inputs A/B: active low (pull to ground)
- Outputs A/B: open collector, 40 VDC max, 40 mA each
- +3.3 VDC pins (2) (300 mA over-current protected)

Configuration & Administration Software

- CONVERGE Console

Power Input Range

- Auto-Adjusting
- 100–240 VAC; 50/60 Hz

Power Consumption

- 30 W Typical

Dimensions (L x D x H)

- 17.25" x 10.25" x 1.75"
- 43.8 x 26 x 4.5 cm

Weight

- 7.5 lbs/3.3375 kg unit weight
- 12 lbs/5.4kg shipping

Operating Temperature

- 14° F/-10° C to 122° F/50° C ambient unit temperature

Approvals

- See *Appendix D: Compliance*
- AES48-2005: AES standard on interconnections — Grounding and EMC practices — Shields of connectors in audio equipment containing active circuitry (self certified)

Part Number

910-151-820 CONVERGE Pro TH20
Telephone Hybrid for CONVERGE Pro 880, 880T, 840T, 8i, and CONVERGE SR 1212

CONVERGE PRO VH20

VoIP Features

- VoIP Features
- SIP V2 (RFC 3261 and companion RFC s)
- Codec Support
 - » G.711u
 - » G.711A
 - » G.722 wideband audio
 - » G.729
 - » G.723.1

Security Features

- Full Security Capability with TLS, AES, SRTP

Noise Cancellation

- Noise Cancellation 6-15 dB attenuation

Audio Performance

- Conditions: Unless otherwise specified, all measurements are performed with a 20 Hz to 22 kHz BW limit (no weighting)
- Frequency Response: 20 Hz to 22 kHz ± 1 dB $R_s=150 \Omega$
- THD+N: $<0.02\%$
- Dynamic Range: 100 dB (non A-weighted)
- Crosstalk <-91 dB re 20 dBu @ 20 kHz channel to channel

Line Inputs 1, 2

- Push-on mini-terminal block, balanced, bridging
- Impedance: $< 10 K\Omega$
- Nominal Level: 0 dBu
- Maximum Level: 20 dBu

Line Outputs 1,2

- Push-on mini-terminal block, balanced
- Impedance: $< 50 k\Omega$
- Nominal Level: 0 dBu
- Maximum Level: 20 dBu

Expansion Bus In/Out

- Proprietary Network
- RJ-45 (2), 1.9 Mbps
- Category 5 twisted-pair cable, 200' maximum cable length between any two CONVERGE/CONVERGE Pro devices

Ethernet

- Autoswitching with Quality of Connection (QoC)
- 10/100 Mbps Ethernet Network Port
- 10/100 Mbps Ethernet PC Port
- RJ-45 Connectors

RS-232

- Serial Command Protocol Only (Console software not supported on RS-232 port)
- DB-9 female
- 9,600/19,200/38,400/57,600/115,200 baud rate; 8 bits, 1 stop bit, no parity
- Hardware flow control on (default)/off

USB

- Version 2.0 compatible
- Type: B-connector

Control/Status Ports

- DB-25 female A/B (2)
- Inputs A/B: active low (pull to ground)
- Outputs A/B: open collector, 40 VDC max, 40 mA each
- +3.3 VDC pins (2) (300 mA over-current protected)

Configuration & Administration Software

- CONVERGE® Console

Network

- Remote Management & Configuration
 - » HTTP web server
 - » Telnet Client
 - » SMTP Client
 - » SNMP Agent
 - » DNS
 - » DHCP

Power Input Range

- Auto-Adjusting
- 100–240 VAC; 50/60 Hz

Power Consumption

- 30 W Typical

Dimensions (L x D x H)

- 17.25" x 10.25" x 1.75"
- 43.8 x 26 x 4.5 cm

Weight

- 7.5 lbs/3.3375 kg unit weight
- 12 lbs/5.4kg shipping

Operating Temperature

- 14° F/-10° C to 122° F/50° C ambient unit temperature

Approvals

- See *Appendix D: Compliance*
- AES48-2005: AES standard on interconnections — Grounding and EMC practices — Shields of connectors in audio equipment containing active circuitry (self certified)

Part Number

- 910-151-825 CONVERGE Pro VH20
- Telephone Interface for CONVERGE/CONVERGE Pro Platform

CONVERGE SR 1212

Audio Performance

- Conditions: Unless otherwise specified, all measurements are performed with a 20 Hz to 22 kHz BW limit (no weighting)
- Frequency Response: 20 Hz to 22 kHz \pm 1 dB
- Noise (EIN): -126 dBu, 22 kHz BW, max gain,
- $R_s=150 \Omega$
- THD+N: <0.02%
- Dynamic Range: >100 dB (non A-weighted)
- Crosstalk <-91 dB re 20 dBu @ 20 kHz channel to channel

Auto Mixer Features

- Number of Open Microphones (NOM)
- PA Adaptive Mode
- First Mic Priority Mode
- Last Mic Mode
- Maximum # of Mics Mode
- Ambient Level
- Gate Threshold Adjust
- Off Attenuation Adjust
- Hold Time
- Decay Rate

Matrix Mixing Features

- 36x36 matrix
- 12 analog in/out
- 12 expansion bus in/out
- 8 assignable processing blocks in/out
- 4 assignable fader blocks in/out

Assignable Processing Blocks

- Filters
 - » All pass
 - » Low pass
 - » High pass
 - » Low shelving
 - » High shelving
 - » Parametric EQ
 - » Notch
 - » CD Horn
- Crossovers
 - » Bessel
 - » Butterworth
 - » Linkwitz-Riley
- Compressor
- Delay; adjustable up to 250 ms

Assignable Fader Blocks

- Gain/Mute

Microphone Input Configuration

- Input Gain Adjust
- Mic or Line Level
- Phantom Power on/off
- Filters
 - » All Pass
 - » Low Pass
 - » High Pass
 - » Notch
 - » PEQ
- Mute on/off
- Chairman Override on/off
- AGC on/off
- Automatic Level Control on/off
- Auto Gate/Manual gate
- Adaptive Ambient on/off

Mic/Line Inputs 1-8

- Push-on mini-terminal block, balanced, bridging
- Impedance: < 10 K Ω
- Nominal Level: adjustable -56 dBu to 0 dBu (7 dB step coarse gain adjustment)
- Maximum Level: -65 dBu to +20 dBu
- Phantom Power: 24 V, selectable

Line Inputs 9-12

- Push-on mini-terminal block, balanced, bridging
- Impedance: < 10 K Ω
- Nominal Level: 0 dBu
- Maximum Level: 20 dBu

Outputs 1-12

- Push-on mini-terminal block, balanced
- Impedance: < 50 Ω
- Nominal Level: 0 dBu
- Maximum Level: 20 dBu

Expansion Bus In/Out

- Proprietary Network
- RJ-45 (2), 1.9 Mbps
- Category 5 twisted-pair cable, 200' maximum cable length between any two Converge/Converge Pro devices

Ethernet

- Autoswitching with Quality of Connection (QoC)
- 10/100 Mbps Ethernet Network Port
- 10/100 Mbps Ethernet PC Port
- RJ-45 Connectors

RS-232

- Serial Command Protocol Only (Console software not supported on RS- 232 port)
- DB-9 female
- 9,600/19,200/38,400/57,600/115,200 baud rate; 8 bits, 1 stop bit, no parity
- Hardware flow control on (default)/off

USB

- Version 2.0 compatible
- Type: B-connector

Control/Status Ports

- DB-25 female A/B (2)
- Inputs A/B: active low (pull to ground)
- Outputs A/B: open collector, 40 VDC max, 40 mA each
- +3.3 VDC pins (2) (300 mA over-current protected)

Configuration & Administration Software

- CONVERGE Console

Power Input Range

- Auto-Adjusting
- 100–240 VAC; 50/60 Hz

Power Consumption

- 30 W Typical

CONVERGE SR 1212 (continued)

Dimensions (L x D x H)

- 17.25" x 10.25" x 1.75"
- 43.8 x 26 x 4.5 cm

Weight

- 7.5 lbs/3.3375 kg unit weight
- 12 lbs/5.4kg shipping weight

Operating Temperature

- 14° F/-10° C to 122° F/50° C ambient unit temperature

Approvals

- See *Appendix D: Compliance*
- AES48-2005: AES standard on interconnections — Grounding and EMC practices — Shields of connectors in audio equipment containing active circuitry (self certified)

Part Number

910-151-900 CONVERGE SR 1212
12x12 Digital Matrix Mixer

CONVERGE SR 1212A

Audio Performance:

Conditions: Unless otherwise specified, all measurements are performed from from 20 HZ to 22 kHz BW limit (no weighting)

- Frequency Response: 20 Hz to 22kHz +- 1 dB
- Noise(EIN): -126 dBu, 20 kHz BW, max Gain
- Rs= 150 ohm
- THD+ Noise: <.02%
- Dynamic Range: >105 dB (non A weighted)
- Crosstalk: <91 db re 20dBu @ 20 kHz channel to channel.

Audio Mixer Parameters

- Number of Open Microphones
- PA Adaptive Mode
- First Mic Priority Mode
- Maximum # of Mics
- Ambient Level
- Gate Threshold Adjust
- Off Attenuation Adjust
- Hold Time
- Decay Rate
- Chairman Override
- 96 Total Microphones per site
- 6- Global Gating Groups

- 4- Internal Gating Groups

Matrix Mixing Parameters

- 8- Microphone Analog Inputs
- 4- Analog Line Inputs
- 8-Analog Line Outputs
- 4- Power Amplifier Outputs
- 18- Expansion Bus in/out

- 8- Processing Blocks

Assignable Processing Blocks

- Filters:
 - » All Pass
 - » Low Pass
 - » Low shelving
 - » High shelving
 - » PEQ
 - » Notch
 - » Crossovers
- Compressor
- Delay up to 250 msec

Power Amplifier Output Processing

- Feedback Elimination w/ ring cancellation
- 10-band EQ filter
- 4- node filter bank for crossover
- Delay Block
- Compressor/Limiter
- Noise Gate for Hiss Control
- Sound Masking Generator per channel
- Adaptive Volume Control
- Multi Channel Control

Microphone Processing

- 4-node filter bank
- AGC/.ALC

Power Amplifier

- Channels: 4
- Amplifier Output: 35-Watt into 8 ohm
- Impedence: Selectable 8ohm, 70V, 100 V

- THD+ Noise: <.2% (1/3 Power)
- Crosstalk: <-68dB

Expansion Bus

- Connection: CAT 5, RJ45
- Mix Minus Structure
- 18 Audio Buses
- 6 Gating Buses
- 8 PA Reference Buses

Network

- 10/100 Auto Switching (PC and Network Port)
- HTTP Server
- Telnet Client
- SNMP Agent
- SNTP Client
- DNS
- DHCP

RS-232

- DB-9
- 9.6k – 115k baud
- 8/1/0
- Hardware Flow Control

USB

- 2.0 Compatible
- Type B connector

GPIO

- DB 25 female (A/B)
- Inputs: Active Low
- Outputs: Open Collector, 40Vdc, 40 mA

Power

- 100-240VAC; 50/60 Hz,
- 300 Watts (maximum)

Environmental

- Operating temperature:
- 32-122 degrees F

Humidity:

- 15 to 80%

Mechanical

- Dimensions: 2RU
- 3.5" H x 17.25" W x 15.92" D
- Weight: < 30 lbs.

Compliance

- EMC- FCC Part 15 Class A
- EMI – EN55024
- Safety - IEC60950, CSA, CCC
- Class 2 Wiring Required

BEAMFORMING MICROPHONE ARRAY

Audio Performance:

Acoustic Characteristics

- 24 microphones
- Auto voice tracking
- Polar Pattern: Custom
- Frequency Response: 150Hz - 16kHz
- Signal to Noise Ratio: >70 dB
- AEC Tail time: 128 ms
- Noise Cancellation: 6 - 15 dB adjustable

Auto Mixer Parameters

- Number of Open Microphones (NOM)
- First mic priority mode
- Last mic mode
- Maximum number of mics mode
- Ambient level
- Gate threshold adjust
- Off attenuation adjust
- Hold time
- Decay Rate

Matrix Mixing Parameters

- 1 Channel In
- 18 Expansion Bus in/out

Beamforming Mic Array Configurations

- Echo cancellation on/off
- Noise cancellation on/off
- Filters:
 - » All Pass
 - » Low Pass
 - » High Pass
 - » Notch
 - » PEQ
- ALC on/off
- Gain adjust
- Mute on/off
- Auto gate/manual gate

Power:

- PoE IEEE 802.3AF-2003
- CAT-5 cable or higher
- 6 watts average power consumption

Expansion Bus In/Out:

- Proprietary Network
- RJ-45 (2)
- Category 5 twisted-pair cable for 200 feet maximum cable length between any two CONVERGE Pro devices

USB:

- Not currently supported - for future use

RS232:

- Commands through CONVERGE Pro

Configuration & Administration Software:

- CONVERGE Console (4.X)

Weight:

- 4.4 lbs. (2.0 Kg.)

Mechanical:

- 30.0" x 1.00" x 5.75" (WxHxD)
(762mm x 25.4mm x 146mm)

Mounting:

- Ceiling mount kit with 12" spanner
- Ceiling mount kit with 24" spanner

Environmental:

- Operating Temperature -
14° F/-10° C to 122° F/50° C ambient temperature

Installation:

- Optimum Mounting Height: About 8 - 10 foot ceiling
- Optimum Coverage Distance:
 - » About 6 - 10 traditional cardioid mics
 - » About 2 - 3 ClearOne ceiling mic array
 - » About 8 - 10 foot radius

Supported CONVERGE Pro Units*

- CONVERGE Pro 840T
 - CONVERGE Pro 880
 - CONVERGE Pro 880T
 - CONVERGE Pro 880TA
- *Maximum 3 Beamforming microphone array per each supported CONVERGE Pro unit and maximum 16 units

Part Numbers:

- 910-001-003: Beamforming Microphone Array
- 910-001-004: PoE Power Supply & Cables Kit for BFM Array
- 910-001-005-12: Ceiling Mount kit with 12 inch spanner for BFM Array
- 910-001-005-24: Ceiling Mount kit with 24 inch spanner for BFM Array

CONNECT COBRANET/DANTE NETWORK BRIDGES

Digital Audio Channels

- 8 X 8

Sampling Rate

- 48 kHz

Dynamic Range

- > 100 dB (non A-weighted)

Power

- LED - Power and Status
- LED - Power and Status
- Input - 100-240V AC @50-60Hz, 0.3A
- Output - 5V DC @1.2A

Connections

- Works with-CONVERGE Pro 840T, 880, 880T, 880TA,8i,TH20, VH20, CONVERGE SR1212, SR1212A, Beamforming Microphone Array

Expansion Bus In

- 1 port, CAT-5, 200 ft

Expansion Bus Out

- 1 port, CAT-5, 200 ft

CobraNet Port (CONNECT CobraNet)

- CAT-5, 328 ft, 10/100 Mbps

CONNECT Dante Ports

- CAT-5, 328 ft, 10/100 Mbps
- Dante Primary and Secondary, 328 ft, 10/100 Mbps, Full-Duplex required

Mechanical

- 4.7" x 5.6" x 1.7" (WxHxD)
(11.9cm x 14.3cm x 4.4cm)

Environmental

- Operating Temperature - 32° - 104°F (0° - 40°C)
- Relative Humidity: 0 to 90%

Mounting Options

- Rack Mount (requires 3-unit rack mount plate)
- Tabletop (rubber feet)
- Underside of the table (built-in mounting flanges)

Part Numbers

- 910-151-805: CONNECT CobraNet Network Bridge
- 910-151-807: CONNECT Dante Network Bridge

CONVERGE USB INTERFACE

Power

- Input - 100-240V AC @50-60Hz, 0.3A
- Output - 5V DC @1.2A

Connections

- Works with-CONVERGE Pro 840T, 880, 880T, 880TA,8i,TH20, VH20, CONVERGE SR1212, SR1212A, Beamforming Microphone Array

Expansion Bus In/Out

- Category 5 twisted-pair cable for 200 feet maximum cable length between any two CONVERGE devices

USB Audio

- USB 2.0 compatible
- Connector: USB-B
- TX and RX Channel: 24Bit at 48 kHz

Control Status

- Tx/Rx channels selectable by terminal block jumpers: K/L, M/N, O/P, Q/R

Weight

- 1.51 lbs (0.75 kg)

Mechanical

- 4.7" x 5.6" x 1.7" (WxHxD)
(11.9cm x 14.3cm x 4.4cm)

Environmental

- 14° F/-10° C to 122° F/50° C ambient temperature

Compliance

- RoHS, WEEE

Part Numbers

- 910-151-806: CONVERGE USB

APPENDIX E: COMPLIANCE



WARNING: The country code must be set correctly in Console to ensure that the unit operates properly when connected to the telco network, and that it complies with the country's telco requirements. Changing this code to a country other than the intended country of operation might cause Converge Pro devices to be non-compliant.

FCC PART 15/ICES-003 COMPLIANCE

This equipment has been tested and found to comply with the limits for a Class A digital device, pursuant to Part 15 of the FCC rules and Industry Canada ICES-003. These limits are designed to provide reasonable protection against harmful interference when the equipment is operated in a commercial environment. This equipment generates, uses, and can radiate radio frequency energy and, if not installed and used in accordance with the instruction manual, may cause harmful interference to radio communications. Operation of this equipment in a residential area is likely to cause harmful interference, in which case the user will be required to correct the interference at his/her own expense.

This device complies with Part 15 of the FCC Rules. Operation is subject to the following two conditions: (1) this device may not cause harmful interference, and (2) this device must accept any interference received including interference that may cause undesired operation.

Changes or modifications not expressly approved by ClearOne Inc. could void the user's authority to operate the equipment.

FCC PART 68 COMPLIANCE

US:FBIBR00BCONVPRO
Ringer Equivalence Number (REN): 0.0B(ac)

This equipment complies with Part 68 of the FCC Rules Requirements adopted by ACTA. On the mixer unit of this equipment contains, among other information, a product identifier in the format US:AAAEQ##TXXXX. If requested, this information must be provided to your telephone company.

The REN is used to determine the number of devices that may be connected to the telephone line. Excessive RENs on the telephone line may result in the devices not ringing in response to an incoming call. In most, but not all areas, the sum of the RENs should not exceed five (5.0). To be certain of the number of devices that may be connected to the line, as determined by the total RENs, contact the telephone company to obtain the maximum RENs for the calling area. The REN for this product is part of the product identifier that has the format US:AAAEQ##TXXXX. The digits represented by ## are the REN without a decimal point (e.g. 03 is a REN of 0.3).

If this equipment causes harm to the telephone network, the telephone company will notify you in advance that temporary discontinuance of service may be required. But if advance notice isn't practical, the telephone company will notify the customer as soon as possible. Also, you will be advised of your right to file a complaint with the FCC if you believe it is necessary.

The telephone company may make changes in its facilities, equipment, operations, or procedures that could affect the operation of the equipment. If this happens, the telephone company will provide advance notice in order for you to make the necessary modifications to maintain uninterrupted service.

This equipment uses an RJ11C jack that is used to connect this equipment to the premises wiring and telephone network. This RJ11C jack complies with the applicable FCC Part 68 Rules and Requirements adopted by the ACTA. A compliant telephone cord and modular plug is provided with this product. It is designed to be connected to a compatible modular jack that is also compliant. See installation instructions for details.

If you experience problems with this equipment, contact ClearOne Inc, 5225 Wiley Post Way, Suite 500, Salt Lake City, Utah 84116, or by phone at (800) 945-7730 for repair and warranty information. If the equipment is causing harm to the telephone network, the telephone company may request you disconnect the equipment until the problem is resolved.

No user serviceable parts are contained in this product. If damage or malfunction occurs, contact ClearOne Inc. for instructions on its repair or return.

Connection to party line service is subject to state tariffs. Contact the state public utility commission, public service commission or corporation commission for information. This equipment cannot be used on telephone company provided coin service.

If your home has specially wired alarm equipment connected to the telephone line, ensure the installation of this equipment does not disable your alarm equipment. If you have questions about what will disable alarm equipment, consult your telephone company or a qualified installer.

ELECTRICAL SAFETY ADVISORY

This equipment uses AC power which can be subjected to electrical surges, typically lightning transients which are very destructive to customer terminal equipment connected to AC power sources. The warranty for this equipment does not cover damage caused by electrical surge or lightning transients. To reduce the risk of this equipment becoming damaged it is suggested that the customer consider installing a surge arrester.

IC COMPLIANCE

IC: 1970A-CONVPRO
Ringer Equivalence Number (REN): 0.0B(ac)

NOTICE: The term "IC" before the certification/registration number signifies that Industry of Canada technical specifications were met.

This certification means that the equipment meets certain telecommunications network protective operational and safety requirements. The Department does not guarantee the equipment will operate to the user's satisfaction.

The REN is used to determine the number of devices that may be connected to the telephone line. Excessive RENs on the telephone line may result in the devices not ringing in response to an incoming call. In most, but not all areas, the sum of the RENs should not exceed five (5.0). To be certain of the number of devices that may be connected to the line, as determined by the total RENs, contact the telephone company to obtain the maximum RENs for the calling area. The REN for this product is listed above.

Before installing this equipment, users should ensure that it is permissible to be connected to the facilities of the local telecommunications company. The equipment must also be installed using an acceptable method of connection. In some cases, the companies inside wiring associated with a single line individual service may be extended by means of a certified connector assembly (telephone extension cord). The customer should be aware that compliance with the above conditions may not prevent degradation of service in some situations.

Repairs to certified equipment should be made by an authorized Canadian maintenance facility designated by ClearOne Inc. Any repairs or alterations made by the user to this equipment, or equipment malfunctions, may give the telecommunications company cause to request the user to disconnect the equipment. Users should ensure for their own protection that the electrical ground connections of the power utility, telephone lines and internal metallic water pipe system, if present, are connected together. This precaution may be particularly important in rural areas.



Details on European compliance can be found on the ClearOne website under resource library.

NEW ZEALAND COMPLIANCE

In the event of main power failure, CONVERGE/CONVERGE Pro equipment will become inoperable with regard to making telephone calls.

All persons using CONVERGE/CONVERGE Pro equipment for recording telephone conversations shall comply with New Zealand law, which requires that at least one party to the conversation be aware that the conversation is being recorded. In addition, the principles enumerated in the Privacy Act of 1993 shall be complied with in respect to the nature of any personal information collected, the purpose of this collection, how it is used, and what is disclosed to any other party.

JAPANESE COMPLIANCE

The DC resistance of the PSTN line is restricted to $1700 - 397 = 1303$ Ohms.

APPENDIX F: PROVISIONING THE CONVERGE VH20

PROVISIONING THE CONVERGE VH20

Overview

This document describes the process of configuring a CONVERGE VH20 using configuration files and compares this to the use of the CONVERGE Console software.

Automatic Provisioning

By default the VH20 is configured to automatically get provisioning information from a TFTP server defined by the DHCP server. This power on default behavior can be changed to configure from a different TFTP server or to stay with current settings. These changes can be made through the Console software by changing the network settings for ENETTFTP (for the TFTP IP address) or ENETPROV (for selecting source for provisioning).

If provisioning has been enabled, at boot time two files will be requested from the TFTP server. These files are named as follows:

CLROVoipConfig.txt

and

CLROVoipConfig_[MAC address].txt

where [MAC address] is the 12 digit hexadecimal MAC address of the VH20 to be configured. Thus the first file can contain settings general to all units and the second file can contain unique settings specific to a unit.

NOTE: Although the settings configuration file may appear to be well formed XML, it MUST adhere to the formatting as defined in this example. Parameter settings CANNOT be spread across multiple lines.

For example:

Valid

```
<username> admin </username>
```

Invalid

```
<username>
```

admin

```
</username>
```

Also, since there are two proxies, each proxy tag can take an index value of 0 or 1 for the primary or secondary proxy. Those tags that take a proxy index are shown within the tag field with index=n where n = 0 or 1. For example, the tag to enable the primary proxy sip authentication would be:

```
<use_sipauth index=0> 1 </use_sipauth>
```

A sample CLROVoipConfig.txt file containing configuration settings is shown below. After the sample file is a complete list of tags and the ranges allowed.

```
<C1CONFIG>
  <dialplan> C1EngDialPlan.txt </dialplan>
  <tls_cert_update> 2 </tls_cert_update>
  <tls_private_cert index=0> C1PKeyCert.txt </tls_private_cert>
  <tls_local_cert index=0> C1LocalCert.txt </tls_local_cert>
  <tls_ca_cert index=0> C1CA0Cert.txt,C1CA1Cert.txt </tls_ca_cert>
</C1CONFIG>
```

All Configuration Tags and Associated Ranges

<ringtone>

ringtone index 1 to 5

<localnum>

Local telephone number

<mute_ringtone>

1 - mute ringer on incoming call 0 - disable mute

<dialplan>

File name of Dialplan - TFTPed from server

<use_sipauth index=n>

1 - enable SIP authentication 0 - disable sip authentication

<sip_username index=n>

sip authentication username

<sip_password index=n>

sip authentication password

<sip_proxy_enable index=n>

1 - enable 0 - disable

<sip_proxy_server index=n>

sip proxy server IP, hostname or FQDN

<sip_proxy_port index=n>

sip proxy server port

range 1024 to 65535

<outbound_sip_proxy_enable index=n>

1 - enable 0 - disable

<outbound_sip_proxy index=n>

sip outbound proxy IP, hostname or FQDN

<outbound_proxy_port index=n>

sip outbound proxy port

range 1024 to 65535

<sip_register_timetout>

sip registration timeout in seconds

<sip_session_timer_enable>

1 - enable 0 - disable

<sip_session_expires_timer>

range 90 to 65535

range: must be greater than or equal to min SE timer (see below)

<sip_min_SE_timer>

range 90 to 65535

<sip_refer_timer>

range 0 to 65535

< sip_retrans_timer_T1 >

range 0 to 65535

< sip_retrans_timer_T2 >

range 0 to 65535

< sip_retrans_timer_T4 >

range 0 to 65535

< sip_transport_index=n >

sip transport: 0 - udp, 1 - tcp, 2 - tls

< sip_udp_port_index=n >

sip udp port
range 1024 to 65535

< sip_tcp_port_index=n >

sip tcp port
range 1024 to 65535

< sip_tls_port_index=n >

sip tls port
range 1024 to 65535

< dtmf_relay_enable >

1 - enable inband dtmf relay 0 - disable

< dtmf_relay_payload >

dtmf relay payload - 96 to 127

< vad_enable >

1 - enable voice activity detection 0 - disable

< adaptive_vad >

1 - enable adaptive vad 0 - disable

< vad_thresh >

vad threshold -20 to +10

< vad_noise_match >

vad noise matching 0 - none, 1 - level

< g72264_priority >

g.722 64kbps codec priority 1(lowest) to 255(highest)

< g72256_priority >

g.722 56kbps codec priority 1(lowest) to 255(highest)

< g72248_priority >

g.722 48kbps codec priority 1(lowest) to 255(highest)

< g711ulaw_priority >

g.711ulaw codec priority 1(lowest) to 255(highest)

< g711alaw_priority >

g.711Alaw codec priority 1(lowest) to 255(highest)

< g729ab_priority >

g.729A/B codec priority 1(lowest) to 255(highest)

< g7231_63_priority >

g.723.1 high rate priority 1(lowest) to 255(highest)

< g7231_53_priority >

g.723.1 low rate priority 1(lowest) to 255(highest)

<vlan_enable>

1 to 4096 enable with this VLANID, 0 – disable VLAN

<vlan_priority>

priority of vlan packets range: 0-7

<qos_precedence>

set quality of service precedence range: 0-8

- 0 0x0
- 1 0x8
- 2 0x10
- 3 0x18
- 4 0x20
- 5 0x28
- 6 0x30
- 7 0x38
- 8 allows a custom value to be specified by qos_custom_dscp.
See qos_custom_dscp below.

<qos_custom_dscp>

A custom value of QOS precedence range 0- 0x39

See qos_precedence above

<auto_answer>

1 - enable 0 - disable

<rtp_base_port>

range 1024 to 65535

<user_domain index=n>

default -to use the current domain name

proxy -to use the proxy address

[Fully qualified domain name] -to specify a domain name

<tls_cert_update index=n>

1 - always update the tls filename and data

2 - if the file name is not present, then request the file data

<tls_private_cert index=n>

file name of private key to load

<tls_local_cert index=n>

file name of local certificate to load

<tls_ca_cert index=n>

comma seperated list of up to 5 CA certificate filenames to be loaded.

<rtcp_enable>

1 - enable 0 - disable

<srtp_enable>

1 - enable 0 - disable

<srtp_cipher>

1 - AES_CM_128

2 - FS_128

<srtp_mac>

1 - HMAC_SHA1_80

2 - HMAC_SHA1_32

<srtp_kdr>

set KDR offer range 0 - 24

<srtp_enable>

1 - enable 0 - disable

The Dial Plan Configuration File

The dial plan configuration file defines rules for gathering digits when dialing a phone number and also defines the mapping of the gathered digits to a specific target. A sample dial plan is defined below.

```
<C1DIALPLAN>
<SYSCONFIG DIALTIME="120000" FIRST_DIGIT_WAIT="30000" INTER_DIGIT_WAIT="30000"
TERMINATION_DIGIT="#"/>
<DIGITMAP MATCH="911" MIN_DIGITS="3" MAX_DIGITS="3" STRIP_FIRST_DIGITS="0" ADD_PREFIX_
AFTER_STRIP="" DIAL_STRING="+&@sipgateway.com"/> <!-- 911 Emergency -->
<DIGITMAP MATCH="+&" MIN_DIGITS="4" MAX_DIGITS="4" STRIP_FIRST_DIGITS="0" ADD_PREFIX_
AFTER_STRIP="" DIAL_STRING="+&@sipproxy.com"/> <!-- Enterprise extensions -->
<DIGITMAP MATCH="9" MIN_DIGITS="8" MAX_DIGITS="43" STRIP_FIRST_DIGITS="1" ADD_PREFIX_
AFTER_STRIP="" DIAL_STRING="+&@sipgateway.com"/> <!-- Outside dialing -->
<DIGITMAP MATCH="0" MIN_DIGITS="1" MAX_DIGITS="1" STRIP_FIRST_DIGITS="0" ADD_PREFIX_
AFTER_STRIP="" DIAL_STRING="operator@sipproxy.com"/> <!-- Operator -->
</C1DIALPLAN>
```

NOTE: All tokens associated with the SYSCONFIG and DIGITMAP MUST appear on separate, single lines in the actual configuration file.

NOTE: Although the dial plan configuration file may appear to be well formed XML, it MUST adhere to the format defined above.

The **DIALTIME** token defines the total time in milliseconds allowed to enter the dialed digits before the phone will play a re-order tone.

The **FIRST_DIGIT_WAIT** token defines the time in milliseconds the phone will wait after going off-hook to enter the first digit before the a re-order tone is played.

The **INTER_DIGIT_WAIT** token defines the time in milliseconds the phone will wait after the first digit is entered before another digit must be entered before the number is dialed.

The **TERMINATION_DIGIT** token defines the termination digit to be entered if the maximum number of digits have not yet been entered and the number is to be dialed before the **INTER_DIGIT_WAIT** timer is still active.

The **MATCH** token defines the digits which MUST be matched when the user begins entering digits for the **DIGITMAP** rule to take effect.

The **MIN_DIGITS** token defines the minimum number of digits which MUST be entered once that match rule has been invoked. This number must be greater than or equal to the number of digits in the **MATCH** string.

The **MAX_DIGITS** token defines the maximum number of digits which MAY be entered after the match rule has been invoked. The completion of the number may be achieved when the maximum number of digits have been entered or the **TERMINATION_DIGIT** is pressed. The **MAX_DIGITS** parameter MUST be greater than or equal to the **MIN_DIGITS** parameter.

The **STRIP_FIRST_DIGITS** parameter defines the number of digits that will be stripped from the beginning of the complete dial string before it is passed to the underlying stack to be dialed. For example if the user entered 1234 and **STRIP_FIRST_DIGITS** was set to 2, the string passed to the underlying stack for dialing would be 34.

The **ADD_PREFIX_AFTER_STRIP** token defines a set of prefix characters that are to be applied to the beginning of the dial string AFTER the **STRIP_FIRST_DIGITS** rule has been applied. Adding to the previous example, if the **ADD_PREFIX_AFTER_STRIP** were set to "56" and the user entered 1234, the string passed to the underlying stack would be 5634.

The **DIAL_STRING** token defines the address which will be dialed when a number satisfying the MATCH rule is entered.

The characters "+&" define a wild card, which can be entered to simplify entering multiple rules for similar addresses. In the example shown above, when any four digit number is entered, it is passed to the stack as "<four digit number>@sipgateway.com".

NOTE: Although the wild card parameter is defined in the MATCH string and in the DIAL_STRING, it assumes that the rules applied for STRIP_FIRST_DIGITS and ADD_PREFIX_AFTER_STRIP still take effect before the entered number replaces the wild card in the DIAL_STRING.

GLOSSARY

Acoustic Echo Cancellation (AEC) A process in which acoustical echo is removed from a signal. AEC can be used to remove unwanted signals from mic audio if the unwanted acoustic signal is available separately as an electronic signal.

Adaptive Ambient This portion of the mixer monitors the varying ambient noise level in the room and changes the threshold level at which a microphone gates on.

Ambient Level A user-defined background noise level used to control microphone gating (used only if Adaptive Ambient is disabled).

Ambient Noise The existing room-level noise, such as that caused by ventilation systems, paper shuffling, and background chatter.

Attack Time Determines how quickly compression is enabled (calibrated in milliseconds). See also Compression, Compressor, and Threshold.

Attenuation A reduction of signal amplitude.

Audible Hook Indication A series of beeps that indicates when the telephone line goes on or off hook. This feature can be turned on or off, and the level can be adjusted in the Telco Rx Channel Configuration window.

Audible Ringer Indication When a call comes in, you can hear it ring if Audible Ringer Indication is turned on in the Telco Rx Channel Configuration window. The ringer level can also be adjusted.

Audio Routing The process of routing input signals to output channels in the Matrix based on default or user-defined cross points. See also Matrix.

Automatic Gain Control (AGC) Automatically increases or decreases audio gain to maintain a consistent audio level.

Automatic Gating Automatically gates microphones on or off based on gating parameters set in the Mic Input Channel Configuration window.

Automatic Level Control (ALC) ALC can be selected for telco receive and mic input channels. ALC keeps soft and loud telephone participants at a consistent level. ALC can be turned on or off in the Telco Rx and Mic Input Channel Configuration windows. The default is on for Telco Rx and on for mic inputs.

Bandwidth The difference between the lower and upper end points of an audio band. Also, the range or differences between the limiting frequencies of a continuous frequency band.

Baud Rate The number of signal transitions per second, or the clock rate of the serial bit stream in hertz. Given 7 or 8 bits for data plus start and stop, the approximate ASCII character transmission rate is one-tenth the baud rate.

Beamformig Microphone Array The Beamforming Microphone Array uses multiple microphone elements to steer its pickup pattern towards participants in the room and reject unwanted noise and reflections.

CD Horn EQ (Constant Directivity Horn Equalizer) Horn drivers used in arenas and auditoriums have an inherent 6dB/octave high frequency rolloff. The CD Horn EQ compensates for this characteristic.

Chairman Override Provides gating priority for chairman override enabled microphones within the same gating group. When a mic with chairman override gates on, all mics that don't have chairman override enabled and are in the same gating group will gate off.

ClearEffect™ To reduce bandwidth requirements, telephone lines limit audio bandwidth to a range of 300Hz-3.3kHz. ClearEffect™ enhances the incoming signal from a telephone line to emulate wideband audio by adding

high and low frequencies to the audio signal, creating a richer, fuller sound. All output signals routed from an input channel with ClearEffect™ enabled are routed as wideband audio.

Clipping Clipping occurs when a signal level exceeds the maximum level a circuit can handle. This is usually caused by improper gain settings. Clipping causes distortion, listener fatigue, and accelerated failure of speakers.

Compression An induced reduction in the dynamic range of all or part of an audio signal. Compression is usually used to protect individual loudspeaker components from damage caused by transient peaks in audio signals.

Compressor A signal processor used to perform compression and control the dynamic range of an audio signal.

Control Bus Part of the Expansion Bus, the Control Bus passes control information to the units. Control is not affected by audio master/slave settings and will continue to function even if the units are not using the audio channels. See also Expansion Bus.

Crossover A device that passes designated frequency ranges of an audio signal to specified loudspeaker elements in a sound system. Converge Pro provides the following types of crossovers:

- **Bessel** A crossover using a low-pass filter design characterized by a linear phase response. This results in a constant time delay throughout the passband.
- **Butterworth** A crossover using a low-pass filter design characterized by a maximally flat magnitude response. This results in no amplitude ripple in the passband.
- **Linkwitz-Riley** A fourth-order crossover consisting of a cascaded second order Butterworth low-pass filter. Offers a vast improvement over the Butterworth crossover and is the de facto standard for professional audio active crossovers.

Cross Point The intersection between an input and an output in the routing matrix. Cross point cells are color coded according to input type: yellow = gated; blue = non-gated; brown = pre-AEC; green = cross point. See also Gating, Pre-AEC Channel.

Cross Point Level Adjust The process of adjusting the audio level (gain/attenuation) at the cross point. Cross Point Levels are set using the Cross Point Attenuation Slider, which allows you attenuate the signal from 0 to -60dB (it also allows you to add gain to the signal, from 0 to 12dB).

Decay Rate Determines how fast a mic input channel gates off after the specified Hold time expires (slow, medium, fast). The default is medium.

Default Meter The input/output level meter displayed on the front panel LED meter. All Converge Pro meters are peak-level meters.

Delay Delay calculates the amount of signal delay based on the distance between audio source and audience, and the temperature. Introducing an appropriate amount of delay can maintain acoustical alignment and proper sound imaging in a room regardless of speaker location. This setting can also compensate for propagation delay caused by signal processing, such as analog to digital conversion. Delay is set in the Channel Property Configuration window for Processing channels. See also Processing Blocks.

Device ID A number which identifies the unit when multiple units of the same device type are connected via the Expansion Bus. All Converge Pro units ship from the factory with a default DID of 0.

Device Type A number which identifies the type of unit. Converge Pro Device Types and Device IDs by model are as follows:

Model	Device Type	Device ID Range
880	1	0-7
TH20	2	0-F
840T	3	0-7
8i	A	0-7

DHCP (Dynamic Host Configuration Protocol) Part of the IP protocol suite, DHCP enables a host server to

dynamically assign IP addresses, subnet masks, default gateways, and other parameters to devices on IP-based networks. See also Default Gateway and Subnet Mask.

Dial Tone Level A setting in the Channel Property Configuration window for Telco Rx channels that allows you to adjust the dial tone level in 1dB steps to ± 12 dB.

DNS (Domain Name System) Part of the IP protocol suite, DNS manages the translation of plain-text internet domain names (URLs) into numeric IP addresses.

DTMF (Dual Tone Multi Frequency) Dialing DTMF or touch-tone dialing allows users to issue tones for access to voice mail, pagers, etc.

DTMF (Dual Tone Multi Frequency) Level A setting in the Channel Property Configuration window for Telco Rx channels used to adjust the level (volume) of the DTMF tones that are heard when dialing. Level can be adjusted in 1dB steps to ± 12 dB.

EC (Echo Canceller) Reference A signal that contains an electronic copy of all signals which will be removed from the signal the mics pick up. This is always the far-end audio and, optionally, local audio sources.

EC (Echo Canceller) Reference Summing The ability to combine multiple signals in a single echo cancellation reference signal. See also Virtual Reference.

ERL (Echo Return Loss) The ERL meter shows the coupling between the reference signal and the input to the echo canceller—the ratio of the two levels.

ERLE (Echo Return Loss Enhancement) The echo return loss enhancement (ERLE) meter shows the loss through the echo cancellation and NLP (non-linear processing) chain—the ratio of the two levels.

Expansion Bus Consists of two RJ-45 connectors (the Link In and Link Out ports) on the rear panel of all Converge Pro models. The Expansion Bus allows multiple Converge Pro devices to be linked together using CAT-5 twisted-pair cable.

Expansion Bus Reference The Expansion Bus Reference allows you to reference an output on another Converge Pro device in a site for Echo Cancellation and PA Adaption.

Filter A device that passes and blocks audio signals based on user-definable requirements of the system.

- **All Pass** A filter that provides only phase shift or phase delay without appreciably changing the magnitude characteristic. The filter produces a flat amplitude response. It is useful for matching the delay of two processing channels with different delays.
- **High Pass** A filter that passes high signal frequencies while attenuating low frequencies.
- **High Shelving** Provides boosting or attenuation of frequencies above a designated frequency. The transition between the spectrum above and below the designated frequency occurs at a fixed 6dB/octave rate. The gain or loss above the corner frequency is adjustable to ± 15 dB.
- **Low Pass** A filter that passes low frequencies while attenuating high frequencies.
- **Low Shelving** Provides boosting or attenuation of frequencies below a designated frequency. The transition between the spectrum above and below the designated frequency occurs at a fixed 6dB/octave rate. The gain or loss below the corner frequency is adjustable to ± 15 dB.

First Mic Priority Increases the audio level required to gate on additional microphones after the first mic is on. This helps ensure that only one mic gates on when a person speaks.

Gain The amount a signal is increased over a given reference, typically 0, normally specified in dB (decibels). On Converge Pro devices, gain is adjustable from -65 to 20dB (85dB range) in .5dB increments.

Gain Structure A set of configuration parameters that define the gain characteristics of a signal. The optimal input gain setting is one which provides both an adequate signal-to-noise ratio and reasonable headroom.

Gateway A device used to provide external network access to client devices on IP networks. All traffic with IP addresses outside the specified subnet mask are automatically routed to the gateway. See also DHCP and Subnet

Mask.

Gating The activation and deactivation of mic inputs. Converge Pro provides three types of microphone gating:

- **Auto** The microphone will gate on according to the input level, assigned gating parameters, and gating group.
- **Manual On** The microphone will gate on unless it exceeds the NOM requirements of the gating group.
- **Manual Off** The microphone is deactivated.

Gate Ratio Specifies how much louder the microphone audio level must be over the ambient sound level before a microphone gates on.

Gating Controls The gating parameters that are assigned to a gating group, including:

- **Maximum Number of Mics** Sets the maximum number of mics that can be gated on simultaneously.
- **First Mic Priority** Increases the audio level required to gate on additional microphones after the first mic is gated on.
- **Last Mic Mode** Sets the last-activated mic to Last On, Mic 1-8, or Off.

Gating Groups A set of gating parameters which can be applied to microphones connected to the local device, or to microphones connected to other units on the Expansion Bus (Global Gating Groups A–D). Gating groups provide greater flexibility and control of mics. See also Global Gating Bus and Expansion Bus.

Global Gating Bus Part of the Expansion Bus, these ten mix-minus buses (I-R) pass mic status and gate parameter information such as First Mic Priority and NOM (Number of Open Mics). See also First Mic Priority and NOM.

GPIO (General Purpose Input/Output) GPIO enables external devices to access the Converge Pro serial command set, including common functions such as volume control, muting, room combining, and preset changes, via the Control/Status A and B ports. All Converge Pro devices connected via the Expansion Bus can be controlled from a single Control/Status port on any of the devices.

Hold Time The length of time that a microphone remains on after the voice (input) level drops below the gate ratio. This can be used to prevent the microphone from gating off during brief pauses in speech.

HTTP (Hyper Text Transfer Protocol) Part of the Internet protocol suite, HTTP is used to transmit information, such as HTML pages, between servers and clients on IP networks.

Last Mic Mode Sets the last-activated mic to Last On, Mic 1-8, or Off. The Last On setting leaves the last-activated mic gated on until another mic input gates on.

Macro A series of commands stored and executed together. Macros can be executed from within Converge Console, using serial commands, and within Presets.

Manual Gating Provides the ability to gate a microphone on or off manually. See also Gating.

Matrix Mixer The Converge Pro mixer that allows routing of any input or combination of inputs to an output or any combination of outputs. The Converge Pro mixer permits level control at each cross point in the matrix. See also Cross Point.

Maximum Number of Mics Sets the maximum number of mics that can be gated on simultaneously.

MIB (Management Information Base) A database file that describes networked communication devices for SNMP management purposes. See also SNMP.

Microphone Mixing The process which mixes audio signals from different microphones. All mic signals can be mixed into one signal, any or all outputs, or mixed into separate groups. Microphone signals can also be processed together or individually.

Min/Max Gain Level Yellow and green limit arrows in Console that set minimum and maximum gain levels respectively for all channels. These arrows are available on the Gain Slider for each channel type. Min/Max limits apply to all serially connected control devices, and are used to prevent users from adjusting levels beyond the specified levels.

Mixer Mode The matrix mixer in Console has two settings: master and slave. Mixer mode is configured in the Unit Properties window. See also Matrix Mixer and Unit Properties.

Mute A condition in which an audio signal is attenuated below the audible threshold.

NLP (Non-Linear Processing) NLP increases the power of echo cancellation for difficult acoustical environments. NLP has four settings: Soft (6dB), Medium (12dB), Aggressive (18dB), and Off. NLP settings are found in the Channel Properties Configuration window for Mic Input channels.

Noise Cancellation A process which removes ambient noise from a signal.

NTP (Network Time Protocol) Part of the IP protocol suite, NTP is used for clock synchronization between devices on IP-based networks.

NOM (Number of Open Mics)/Constant Gain Mode Adjusts the output level to maintain a specified gain level based on the number of mics gated on and routed to an output.

I-R Buses These ten audio buses are used for routing microphone audio between Converge Pro devices. Information about the number of gated microphones (NOM count) and other relevant information for the microphone mixers are tracked for microphones routed to these buses. See also S-Z Buses and PA Adapt/AEC Reference Bus.

Off Attenuation The amount of level reduction a microphone is given when the microphone is not gated on.

PA Adaptive Mode PA Adaptive Mode allows you to specify an output as the ambient reference. This prevents an audio signal from gating on microphones without interfering with speech from conference participants.

PA Adapt/AEC Reference This setting determines which output channel (typically a loudspeaker) is used as the reference for AEC. See also PA Adaptive Mode and AEC.

Parametric Equalizer (PEQ) A multi-band variable equalizer with control of gain, center frequency, and bandwidth. A properly configured PEQ enables Converge Pro devices to offset speaker anomalies and room acoustic imaging deficiencies.

Phantom Power Power supplied by Converge Pro units to power condenser microphones. This feature can be switched off for microphones that do not require phantom power.

Pink Noise An audio test signal containing all the frequencies in a given audio spectrum, with equal energy in each octave.

Pre-AEC Cross Point Setting a Pre-AEC Cross Point in the Matrix bypasses the cross-pointed input audio from the AEC (Acoustic Echo Cancellation) reference. This is primarily used for sound reinforcement applications to prevent mic input channel audio from being degraded by AEC artifacts. See also AEC and Matrix Mixer.

Preset Presets provide the configuration flexibility needed to meet changing conference room requirements. These changes include audio routing, gating, muting, levels, AEC referencing, and signal processing, as well as room combining and room configuration. Presets allow you to make configuration changes instantaneously—without interrupting or affecting any conferences in progress. There are 32 presets available on every Converge Pro device.

Preset Mask Defines whether a Preset executes on a low or high contact closure signal on the rear panel of the unit.

Preset Mode Preset mode is used to create presets and is accessed from the Console toolbar.

Processing Blocks Processing blocks enable you to configure filters, delay, compression, and gain to create precise audio configurations for any venue. A single input or group of inputs can be routed through a processing block and then routed to an output or multiple outputs. There are four processing blocks available for the 840T and eight for the 880 and 8I (A-D for 840T, A-H for 880 and 8I). See also Filters, Delay, Compression, and Matrix.

Q (Quality Factor) It is the ratio of the center frequency divided by the bandwidth. Q reflects an inverse relationship to the bandwidth, and is adjustable from .02:1 to 40:1.

Ratio The amount of compression applied to the output signal compared with the input signal as the signal exceeds the threshold level. See also Compressor, Compression, and Threshold.

Release Time Release is a parameter which determines how quickly compression is released after the input signal drops below the specified threshold. See also Compressor, Compression, and Ratio.

Reverberation A diffused acoustic energy field fed and maintained by sound reflections from the room surfaces.

S-Z Buses These eight buses are line input mixer buses. They are used to route auxiliary audio, such as from a CD player or VCR, to and from other units on the Expansion Bus. These buses are also used as mic mixer buses when NOM count is not required. See also Expansion Bus.

Signal Generator A device for generating a reference tone for sound system calibration purposes.

Site File Site Files allow you to store configuration settings for one or more Converge Pro devices, including Inputs, Outputs, Fader channels, Processing channels, Matrix routing, and Presets, for a specific application or venue. Site files also provide Console with the necessary information to communicate with site hardware using your PC.

Site Properties The Site Properties window opens when you select New Site from the File menu or click on the New Site button on the Console button bar. It allows you to enter information about the site as well as configure the communication and security settings.

SMTP (Simple Mail Transport Protocol) Part of the IP protocol suite, SMTP servers resolve the DNS address and recipient information used to transport email messages over IP networks. See also DNS.

Subnet Mask A subnet mask defines the range logical IP addresses used for internal network traffic, and is used by DHCP, gateway devices, and routers to distinguish between internal and external network traffic on IP networks. See also DHCP, Gateway, and DNS.

TERL (Telco Echo Return Loss) The TERL meter shows the coupling between the transmit signal and the input to the telephone echo canceller. It is the ratio of the two levels.

TERLE (Telco Echo Return Loss Enhancement) The TERLE meter shows the loss through the telephone echo cancellation process. It is the ratio of the two levels.

Threshold The upper or lower level at which a signal processing begins or terminates.

Unit Properties Unit Properties define properties for a specific Converge Pro unit. Unit Properties enable you to configure unit settings such as name, and telephone country code, as well as IP and serial communication settings. See also Site Properties.

Virtual AEC Reference Virtual AEC References allow you to combine multiple audio sources for applications where there are two speakers (left and right), combined audio/video conferencing, and audio/video teleconferencing. In these and other multiple output applications, using virtual AEC references improves AEC performance.

Web Builder Web Builder consists of User Console and Control Console. These consoles allow you to configure a subset of call management (User Console) and mixing features (Control Console) for access through a web portal integrated into the CONVERGE Pro firmware. The web portal can be accessed over IP with Microsoft's Internet Explorer web browser (requires IE version 5.5 or later).

White Noise Acoustical noise with equal energy throughout a given frequency range.

HEADQUARTERS:

Salt Lake City, UT USA

5225 Wiley Post Way
Suite 500
Salt Lake City, UT 84116

Tel: +801.975.7200
Toll Free: +800.945.7730
Sales: +800.707.6994
Fax: +801.303.5711
e-mail: sales@clearone.com

Europe & Oceania

Tel: +44.1454.616.977
e-mail: global@clearone.com

Asia Pacific

Tel: +852.3590.4526
e-mail: global@clearone.com

Latin America

Tel: +801.974.3621
e-mail: global@clearone.com

Middle East

Tel: +852.3590.4526
e-mail: global@clearone.com

Technical Support

Tel: +800.283.5936
e-mail: tech.support@clearone.com