

**Figure 1. Assembly of the
4-Post Modular Rack.**

TRADEMARKS USED IN THIS MANUAL

Black Box and the Double Diamond logo are registered trademarks of BB Technologies, Inc.

Any other trademarks mentioned in this manual are acknowledged to be the property of the trademark owners.

© Copyright 2009. Black Box Corporation. All rights reserved.

1000 Park Drive • Lawrence, PA 15055-1018 • 724-746-5500 • Fax 724-746-0746



4-Post Modular Rack with Adjustable M6 Rails

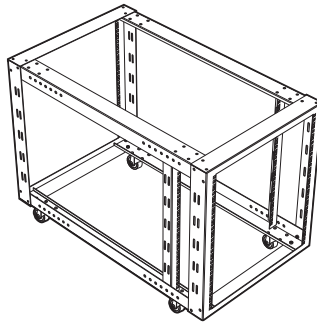

Specifications

Finish: Black powder coat

Load Capacity: 350 lb. (159 kg)

Material: 14-gauge steel

Max. Rail Depth: 35 $\frac{7}{8}$ " (91.1 cm)

Min. Rail Depth: 3 $\frac{3}{4}$ " (9.5 cm)

Size: 23"H (25 $\frac{3}{4}$ " with casters) x 21"W x
36"D (58 [65.4 with casters] x 53.3 x
91.4 cm)

Weight: 35 lb. (15.9 kg)

Overview

The 4-Post Modular Rack is a portable, open-design rack that's great for frequent moves, adds, and changes.

What's Included

- (2) front/rear frames, 12U
- (4) front to rear rails
- (2) movable EIA mounting rails, 12U
- (52) $\frac{1}{4}$ " hex head bolts
- (36) $\frac{1}{4}$ " steel washers
- (4) 2" swivel casters
- (16) $\frac{1}{4}$ " star nuts (for mounting casters)
- (16) M6 cage nuts (for mounting equipment)
- (16) M6 screws (for mounting equipment)

CUSTOMER SUPPORT INFORMATION

Order toll-free in the U.S.: Call 877-877-BBOX (outside U.S. call 724-746-5500)
FREE technical support 24 hours a day, 7 days a week: Call 724-746-5500 or fax 724-746-0746
Mailing address: **Black Box Corporation**, 1000 Park Drive, Lawrence, PA 15055-1018
Web site: www.blackbox.com • E-mail: info@blackbox.com