

DS-X2-FC10G-SR-AO

Cisco® DS-X2-FC10G-SR Compatible TAA 10GBase-SR X2 Transceiver (MMF, 850nm, 300m, SC, DOM)

Features

- X2 MSA 2.0 Compliance
- Duplex SC Connector
- Commercial Temperature 0 to 70 Celsius
- Multi-mode Fiber
- Hot Pluggable
- Excellent ESD Protection
- Metal with Lower EMI
- RoHS Compliant and Lead Free



Applications

- 8x/10x Fibre Channel
- 10GBase-SR Ethernet
- Access, Datacenter and Enterprise
- Mobile Fronthaul CPRI/OBSAI

Product Description

This Cisco® DS-X2-FC10G-SR compatible X2 transceiver provides 10GBase-SR throughput up to 300m over multi-mode fiber (MMF) using a wavelength of 850nm via a SC connector. It is guaranteed to be 100% compatible with the equivalent Cisco® transceiver. This easy to install, hot swappable transceiver has been programmed, uniquely serialized and data-traffic and application tested to ensure that it will initialize and perform identically. Digital optical monitoring (DOM) support is also present to allow access to real-time operating parameters. This transceiver is Trade Agreements Act (TAA) compliant. We stand behind the quality of our products and proudly offer a limited lifetime warranty.

AddOn's transceivers are RoHS compliant and lead-free.

TAA refers to the Trade Agreements Act (19 U.S.C. & 2501-2581), which is intended to foster fair and open international trade. TAA requires that the U.S. Government may acquire only "U.S. – made or designated country end products."



Absolute Maximum Ratings

Parameter	Symbol	Min.	Typ.	Max.	Unit
Storage Ambient Temperature	T _S	-40		85	°C
Supply Voltage (3.3V)	V ₃	0		4	V
Supply Voltage (APS)	V _{APS}	0		1.5	V
Optical Receiver Input	P _{IMAX}			1	dBm

General Specifications

Parameter	Symbol	Min.	Typ.	Max.	Unit
Data Rate	DR		10.3125		GBd
Bit Error Rate	BER			10 ⁻¹²	
Total Power Consumption	P			2.2	W
Supply Voltage (+3.3V)	V _{CC3}	3.14	3.3	3.47	V
Supply Voltage (APS)	V _{CCAPS}	1.152	1.2	1.248	V
Supply Current (+3.3V)	I _{CC3}			300	mA
Supply Current (APS)	I _{CCAPS}			1000	mA
Case Operating Temperature	T _C	0		70	°C

Link Distance

Parameter	Fiber Type	Modal Bandwidth@ 850nm (MHz-km)	Distance Range (m)
10.3 GBd	62.5/125μm MMF	160	2-26
	62.5/125μm MMF	200	2-33
	50/125μm MMF	400	2-66
	50/125μm MMF	500	2-82
	50/125μm MMF	2000	2-300

Electrical Characteristics - DC

Parameter	Symbol	Min.	Typ.	Max.	Unit	Notes
A. 1.2V COMS I/O DC Characteristics (PRTAD; LASI; RESET; TX_ON/OFF)						
External Pull-Up Resistor for Open Drain	R_{PU}	10		22	$K\Omega$	
Output High Voltage	V_{OH}	1			V	
Output Low Voltage	V_{OL}			0.15	V	
Input High Voltage	V_{IH}	0.84		1.2	V	
Input Low Voltage	V_{IL}			0.36	V	
Input Pull-Down Current	IPD	20	120	120	μA	$V_{IN}=1.2V$
B. XAUI I/O DC Characteristics (TXLAN[0..3]; RXLANE[0..3])						
Differential Input Amplitude (pk-pk)	V_{IN_XAUI}	200		1600	mV	AC Coupled
Differential output Amplitude (pk-pk)	V_{OUT_XAUI}	800		1600	mV	AC Coupled
C. MDIO I/O DC Characteristics (MDIO; MDC)						
Output Low Voltage	V_{OL}			0.2	V	$I_{OL} = 100\mu A$
Output Low Current	I_{OL}			4	mA	
Input High Voltage	V_{IH}	0.84		1.2	V	
Input Low Voltage	V_{IL}			0.36	V	
Pull-Up Supply Voltage	V_{PU}		1.2		V	
Input Capacitance	C_{IN}			10	pF	
Load Capacitance	C_{LOAD}			470	pF	
External Pull-Up Resistance	RPU	200			Ω	

Electrical Characteristics - AC

Parameter	Symbol	Min.	Typ.	Max.	Unit	Notes
A. XAUI Input AC Characteristics (TXLANE[0..3])						
Baud Rate	BR _{XAUI_IN}		3.125		GBd	
Baud Rate Tolerance	BR _{TOL_XAUI}	-100		100	ppm	
Differential Input Impedance	Z _{IN_XAUI}		100		Ω	
Differential Return Loss	RL _{IN}	10			dB	100MHz to 2.5 GHz
Input Differential Skew	T _{IN_SKEW}			75	ps	Crossing Point
Jitter Amplitude Tolerance	J _{XAUI_TOL}			0.65	UI _{pp}	IEEE 802.3ae
B. XAUI Output AC Characteristics (RXLANE[0..3])						
Baud Rate	BR _{XAUI_OUT}		3.125		GBd	
Baud Rate Variation	BR _{XAUI_VAR}	-100		100	ppm	
XAUI Eye Mask (far-end)		According to IEEE 802.3ae				
Output Differential Skew	T _{OUT_SKEW}			15	ps	
Output Differential Impedance	Z _{OUT_XAUI}		100		Ω	DC
Differential Output Return Loss	RL _{OUT}	10			dB	100 MHz to 2.5 GHz
Total Jitter	TJ _{XAUI}			0.35	UI	Near-end No pre-equalization 1 UI=320 ps
Deterministic Jitter	DJ _{XAUI}			0.17	UI	
C. Power-On Reset Characteristics						
Power-On Reset and TX_ONOFF Characteristics		According to X2 MSA Issue				
D. MDIO I/O AC Characteristics (MDIO; MDC)						
MDIO Data Hold Time	T _{HOLD}	10			ns	
MDIO Data Setup Time	T _{SU}	10			ns	
Delay from MDC Rising Edge to MDIO Data Change	T _{DELAY}			300	ns	
MDC Clock Rate	f _{MAX}			2.5	MHz	

Optical Characteristics

Parameter	Symbol	Min.	Typ.	Max.	Unit	Notes
Transmitter						
Optical Wavelength	λ	840	850	860	nm	
Launch Power	P_{OUT}	-7.3		-1.3	dBm	
Launch Power in OMA	P_{OUT_OMA}	-4.3		-2.8	dBm	
Launch Power of OFF Transmitter	P_{OUT_OFF}			-30	dBm	
Side Mode Suppression Ratio	SMSR	30			dB	
Spectral Width (RMS)	$\Delta \lambda$			0.45	nm	
Optical Extinction Ratio	ER	3			dB	
Optical Modulation amplitude	OMA	525			μ W	
Optical Return Loss Tolerance	ORL_T			12	dB	
Relative Intensity Noise	RIN			-128	dB/Hz	
Transmitter Dispersion Penalty	TDP			3.9	dB	
Eye Mask Definition		According to IEE 802.3ae and 10Gbase-SR				
Receiver						
Center Wavelength Range	λ_C	840		860	nm	
Optical Input Power	P_{IN}	-9.9		-1	dBm	
Receiver Sensitivity in OMA	P_{IN_OMA}			-11.1	dBm	
Stressed Receiver Sensitivity	P_{IN_S}			-7.5	dBm	
Receiver Reflectance	TR_{RX}			-12	dB	
Receiver electrical 3dB upper cutoff frequency	FR			12.3	GHz	

Pin Descriptions

Pin#	Symbol	I/O	Logic	Description	Pin#
1	GND	I	Supply	Electrical ground	1
2	GND	I	Supply	Electrical ground	2
3	GND	I	Supply	Electrical ground	3
4	5.0V	I	Supply	Power	4
5	3.3V	I	Supply	Power	5
6	3.3V	I	Supply	Power	6
7	APS	I	Supply	Adaptive Power Supply	7
8	APS	I	Supply	Adaptive Power Supply	8
9	LASI	O	Open Drain	Link Alarm Status Interrupt. 10-22k ohm pull up on host	9
10	REST	I	1.2V CMOS	TX OFF when MDIO RESET	10
11	VEND SPECIFIC			Vendor Specific Pin. Leave unconnected	11
12	TX ON/OFF	I	1.2V CMOS	Transmitter ON/OFF	12
13	Reserved			Reserved	13
14	MOD DETECT	O		Pulled low inside module through 1k ohm	14
15	VEND SPECIFIC			Vendor Specific Pin. Leave unconnected	15
16	VEND SPECIFIC			Vender Specific Pin. Leave unconnected	16
17	MDIO	I/O	Open Drain	Management Data IO	17
18	MDC	I	1.2V CMOS	Management data clock	18
19	PRTAD4	I	1.2V CMOS	Port Address bit 4 (Low=0)	19
20	PRTAD3	I	1.2V CMOS	Port Address bit 3 (Low=0)	20
21	PRTAD2	I	1.2V CMOS	Port Address bit 2 (Low=0)	21
22	PRTAD1	I	1.2V CMOS	Port Address bit 1 (Low=0)	22
23	PRTAD0	I	1.2V CMOS	Port Address bit 0 (Low=0)	23
24	VEND SPECIFIC			Vendor Specific Pin. Leave unconnected	24
25	APS SET	O		Feedback output for APS	25
26	RESERVED			Reserved for Avalanche Photodiode use	26
27	APS SENSE	O	Analog	APS Sense Connection	27
28	APS	I	Supply	Adaptive Power Supply	28
29	APS	I	Supply	Adaptive Power Supply	29
30	3.3V	I	Supply	Power	30
31	3.3V	I	Supply	Power	31
32	5.0V		Supply	Power	32
33	GND	I	Supply	Electrical Ground	33
34	GND	I	Supply	Electrical Ground	34
35	GND	I	Supply	Electrical Ground	35
36	GND	I	Supply	Electrical Ground	36
37	GND	I	Supply	Electrical Ground	37
38	RESERVED			Reserved	38

39	RESERVED			Reserved	39
40	GND	I	Supply	Electrical ground	40
41	RX LANE 0+	O	AC	Module XAUI Output Lane 0+	41
42	RX LANE 0-	O	AC	Module XAUI Output Lane 0-	42
43	GND	I	Supply	Electrical ground	43
44	RX LANE 1+	O	AC	Module XAUI Output Lane 1+	44
45	RX LANE 1-	O	AC	Module XAUI Output Lane 1-	45
46	GND	I	Supply	Electrical ground	46
47	RX LANE 2+	O	AC	Module XAUI Output Lane 2+	47
48	RX LANE 2-	O	AC	Module XAUI Output Lane 2-	48
49	GND	I	Supply	Electrical ground	49
50	RX LANE 3+	O	AC	Module XAUI Output Lane 3+	50
51	RX LANE 3-	O	AC	Module XAUI Output Lane 3-	51
52	GND	I	Supply	Electrical ground	52
53	GND	I	Supply	Electrical ground	53
54	GND	I	Supply	Electrical ground	54
55	TX LANE 0+	O	AC	Module XAUI Input Lane 0+	55
56	TX LANE 0-	O	AC	Module XAUI Input Lane 0-	56
57	GND	I	Supply	Electrical ground	57
58	TX LANE 1+	O	AC	Module XAUI Input Lane 1+	58
59	TX LANE 1-	O	AC	Module XAUI Input Lane 1-	59
60	GND	I	Supply	Electrical ground	60
61	TX LANE 2+	O	AC	Module XAUI Input Lane 2+	61
62	TX LANE 2-	O	AC	Module XAUI Input Lane 2-	62
63	GND	I	Supply	Electrical ground	63
64	TX LANE 3+	O	AC	Module XAUI Input Lane 3+	64
65	TX LANE 3-	O	AC	Module XAUI Input Lane 3-	65
66	GND	I	Supply	Electrical ground	66
67	RESERVED			Reserved	67
68	RESERVED			Reserved	68
69	GND	I	Supply	Electrical Ground	69
70	GND	I	Supply	Electrical Ground	70

Electrical Pad Layout

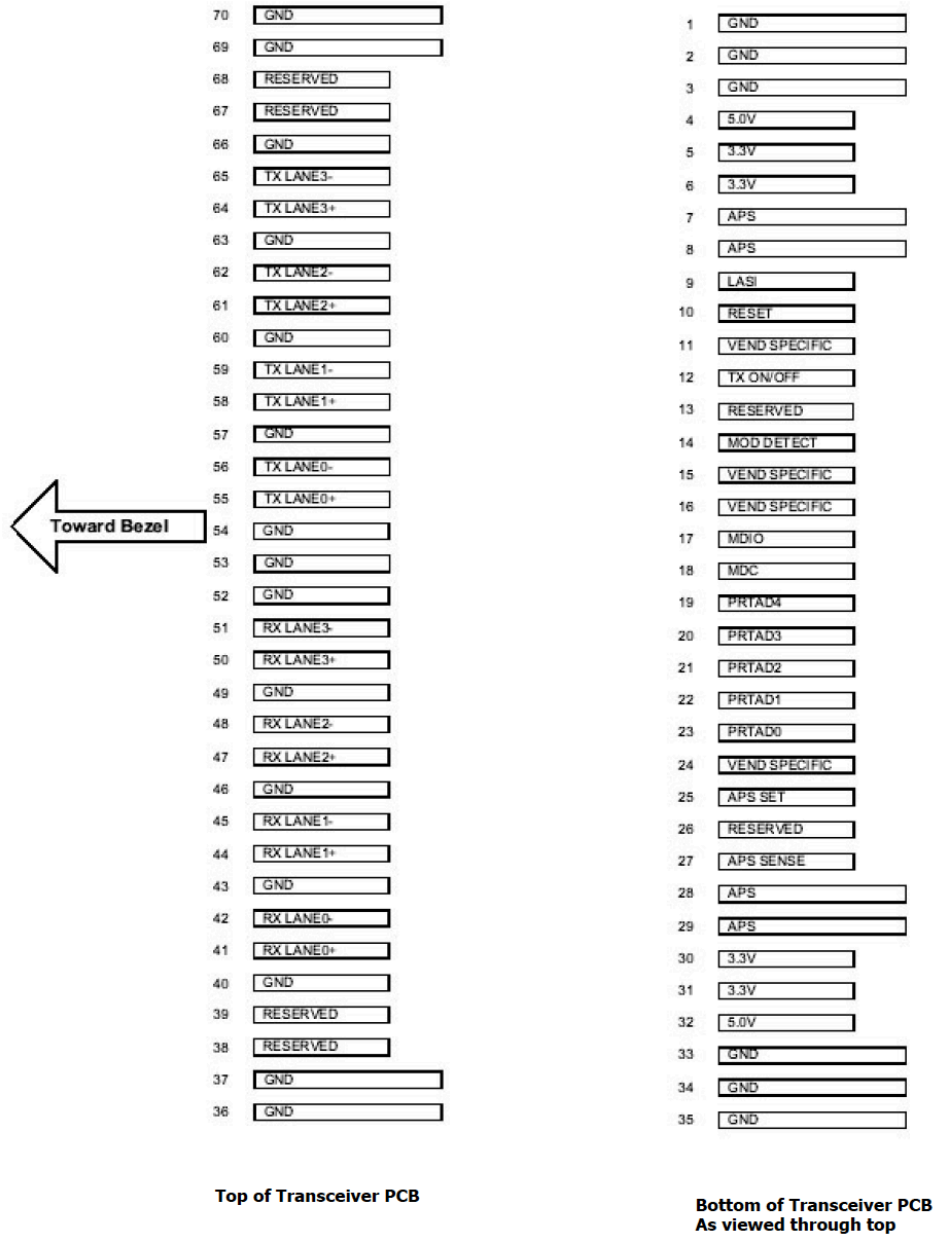

Digital Diagnostic

Parameter	Symbol	Min.	Typ.	Max.	Unit	Notes
Temperature Monitor	T _{MON}	-5		5	°C	
Laser Bias Monitor	I _{MON}	-10		10	%	
TX Power Monitor	P _{TX}	-3		3	dBm	
RX Power Monitor	P _{RX}	-3		3	dBm	

Mechanical Specifications

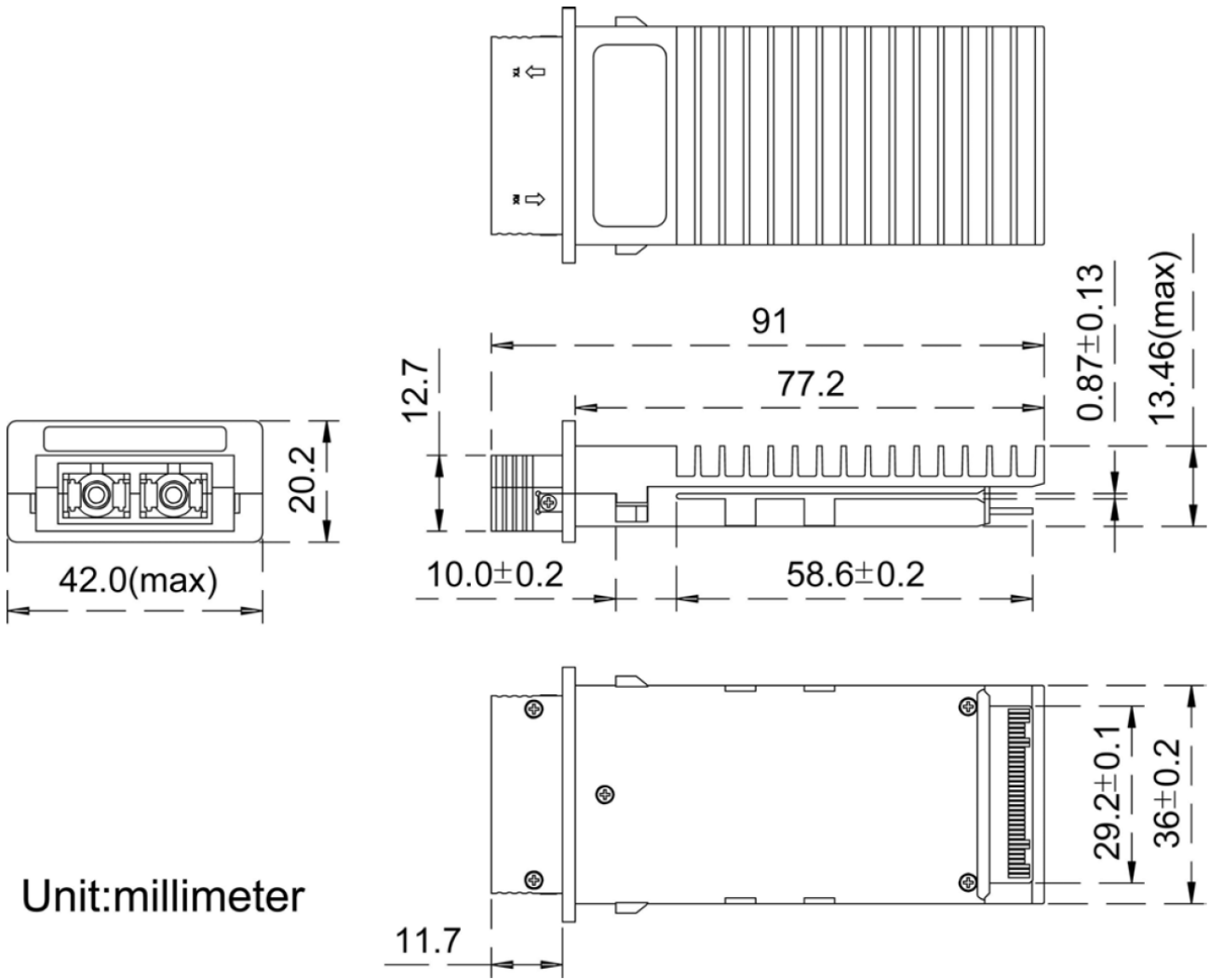

Unit: millimeter

About AddOn Networks

In 1999, AddOn Networks entered the market with a single product. Our founders fulfilled a severe shortage for compatible, cost-effective optical transceivers that compete at the same performance levels as leading OEM manufacturers. Adhering to the idea of redefining service and product quality not previously had in the fiber optic networking industry, AddOn invested resources in solution design, production, fulfillment, and global support.

Combining one of the most extensive and stringent testing processes in the industry, an exceptional free tech support center, and a consistent roll-out of innovative technologies, AddOn has continually set industry standards of quality and reliability throughout its history.

Reliability is the cornerstone of any optical fiber network and is engrained in AddOn's DNA. It has played a key role in nurturing the long-term relationships developed over the years with customers. AddOn remains committed to exceeding industry standards with certifications from ranging from NEBS Level 3 to ISO 9001:2005 with every new development while maintaining the signature reliability of its products.



U.S. Headquarters

Email: sales@addonnetworks.com

Telephone: +1 877.292.1701

Fax: 949.266.9273

Europe Headquarters

Email: salesupportemea@addonnetworks.com

Telephone: +44 1285 842070