



# USERS GUIDE



## INFOCUS QUANTUM LASER AUTHENTIC I

**InFocus**

REGULATORY MODEL	SERIES	LENS TYPE/ RESOLUTION	WXGA	1080P	WUXGA	4K
P135	INFOCUS QUANTUM LASER AUTHENTIC I	STANDARD THROW	–	IN1048SL	IN10489L	–



# Safety Instructions

	The lightning flash with arrow head within an equilateral triangle is intended to alert the user to the presence of uninsulated “dangerous voltage” within the product’s enclosure that may be of sufficient magnitude to constitute a risk of electric shock to persons.
	The exclamation point within an equilateral triangle is intended to alert the user to the presence of important operating and maintenance (servicing) instructions in the literature accompanying the appliance.

**WARNING:** TO REDUCE THE RISK OF FIRE OR ELECTRIC SHOCK, DO NOT EXPOSE THIS APPLIANCE TO RAIN OR MOISTURE. DANGEROUS HIGH VOLTAGES ARE PRESENT INSIDE THE ENCLOSURE. DO NOT OPEN THE CABINET. REFER SERVICING TO QUALIFIED PERSONNEL ONLY.

## Important Safety Instruction

1. Do not block any ventilation openings. To ensure reliable operation of the projector and to protect from over heating, it is recommended to install the projector in a location that does not block ventilation. As an example, do not place the projector on a crowded coffee table, sofa, bed, etc. Do not put the projector in an enclosure such as a book case or a cabinet that restricts air flow.
2. Do not use the projector near water or moisture. To reduce the risk of fire and/or electric shock, do not expose the projector to rain or moisture.
3. Do not install near heat sources such as radiators, heaters, stoves or any other apparatus such as amplifiers that emit heat.

4. Clean only with dry cloth.

5. Only use attachments/accessories specified by the manufacturer.

6. Do not use the unit if it has been physically damaged or abused.

Physical damage/abuse would be (but not limited to):

- Unit has been dropped.
- Power supply cord or plug has been damaged.
- Liquid has been spilled on to the projector.
- Projector has been exposed to rain or moisture.
- Something has fallen in the projector or something is loose inside.

Do not attempt to service the unit yourself. Opening or removing covers may expose you to dangerous voltages or other hazards. Please call InFocus before you send the unit for repair.

7. Do not let objects or liquids enter the projector. They may touch dangerous voltage points and short out parts that could result in fire or electric shock.
8. See projector enclosure for safety related markings.
9. The unit should only be repaired by appropriate service personnel.

## **Intended Use Statement**



- Operation Temperature:
  - For 0 - 2500 ft, 5°C ~ 40°C
  - For 2500 - 5000 ft, 5°C ~ 35°C
  - For 5000 - 10000 ft, 5°C ~ 30°C
- Maximum Humidity:
  - Operating: 10%~80% RH (Max.), Non-condensing
  - Storage: 5%~95% RH, Non-condensing

The ambient operating environment should be free of airborne smoke, grease, oil and other contaminants that can affect the operation or performance of the projector.

Use of this product in adverse conditions will void the product warranty.

## Safety Information

Please read, understand, and follow all safety information contained in these instructions prior to the use of this projector. Retain these instructions for future reference.

Explanation of Signal Word Consequences	
 <b>Warning:</b>	Indicates a potentially hazardous situation, which, if not avoided, could result in death or serious injury and/or property damage.
 <b>Caution:</b>	Indicates a potentially hazardous situation, which, if not avoided, may result in minor or moderate injury and/or property damage.
 <b>Warning:</b>	Hazardous voltage

 <b>Warning:</b>
<p><b>To reduce the risk associated with hazardous voltage:</b></p> <ul style="list-style-type: none"><li>• Do not modify this product in any way.</li><li>• Do not attempt to service this projector.</li><li>• There are no user-serviceable parts. Service to be performed only by a InFocus authorized service provider using InFocus approved system components.</li></ul> <p><b>To reduce the risk associated with fire and explosion:</b></p> <ul style="list-style-type: none"><li>• Do not immerse the projector in any liquid or allow to get wet.</li></ul> <p><b>To reduce the risks associated with choking:</b></p> <ul style="list-style-type: none"><li>• Keep all small parts like the remote control battery away from young children and pets.</li></ul> <p><b>To reduce the risk associated with hazardous voltage, impact, tripping, and intense visible light:</b></p> <ul style="list-style-type: none"><li>• Do not use this projector around unsupervised children.</li></ul>

 <b>Caution:</b>
<p><b>To reduce the risks associated with hearing loss:</b></p> <ul style="list-style-type: none"><li>• Be sure to read earphone manufacturer's instructions with respect to volume level.</li><li>• User is responsible to set a safe volume level.</li></ul> <p><b>To reduce the risk associated with explosion, and/or chemicals from a leaking batteries:</b></p> <ul style="list-style-type: none"><li>• Use with two AAA batteries.</li><li>• Orient the battery's plus (+) and minus (-) terminals of the batteries according to the markings found on the remote control.</li><li>• Do not leave the batteries in the remote for an extended period of time.</li><li>• Do not heat or expose the batteries to fire.</li><li>• Do not disassemble, short, or recharge the batteries.</li><li>• Do not carry batteries loose in your pocket or purse.</li><li>• Avoid eye and skin contact in the event a battery leaks.</li></ul> <p><b>To reduce the risk associated with environmental contamination:</b></p> <ul style="list-style-type: none"><li>• Dispose of all system components in accordance with applicable government regulations.</li></ul> <p><b>To reduce the risks associated with Laser light:</b></p> <ul style="list-style-type: none"><li>• Do not stare directly into the projector lens.</li></ul> <p><b>To reduce the risks associated with tripping and falling:</b></p> <ul style="list-style-type: none"><li>• Position the power cord and data cables so that they are not a tripping hazard.</li></ul>

**IMPORTANT!** Do not expose the projector to direct sunlight in a closed space such as a vehicle.

**SAVE THESE INSTRUCTIONS**

## Safety Labels

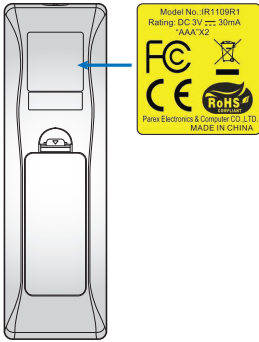

## Trademarks

InFocus and the InFocus logo are trademarks of InFocus Corporation.

Adobe and the Adobe logo are either registered trademarks or trademarks of Adobe Systems Incorporated in the United States and/or other countries.

Microsoft, PowerPoint, and Excel are registered trademarks of Microsoft Corporation.

All other trademarks or registered trademarks are property of their respective companies.

## Regulatory Notices

### FCC STATEMENT - CLASS B

This equipment generates, uses and can radiate radio frequency energy, and if not installed and used in accordance with the instruction manual may cause interference to radio communications. It has been tested and found to comply with the limits for a Class “B” computing device pursuant to Subpart B of Part 15 of the FCC Rules, which are designed to provide reasonable protection against such interference when operated in a residential installation. However, there is no guarantee that interference will not occur in a particular installation. If this equipment does cause harmful interference to radio or television reception, which can be determined by turning the equipment off and on, the user is encouraged to try to correct the interference by one or more of the following measures:

- Reorient or relocate the receiving antenna.
- Increase the separation between the equipment and receiver.
- Connect the equipment into an outlet on a circuit different from that to which the receiver is connected.
- Consult the dealer or an experienced radio/TV technician for help.

**NOTICE:** This Class B digital apparatus complies with Canadian ICES-003.

Cet appareil numérique de la classe B est conforme à la norme NMB-003 du Canada.

### Industry Canada regulatory information

Operation is subject to the following two conditions:

- (1) this device may not cause interference, and
- (2) this device must accept any interference, including interference that may cause undesired operation of the device.

The user is cautioned that this device should be used only as specified within this manual to meet RF exposure requirements. Use of this device in a manner inconsistent with this manual could lead to excessive RF exposure conditions.

**INSTRUCTIONS TO USERS:** This equipment complies with the requirements of FCC equipment provided that the following conditions are met. If the cables include a EMI ferrite core, attach the ferrite core end of the cable to the projector. Use the cables which are included with the projector or specified.

**Note:** *Changes or modifications not expressly approved by the party responsible for compliance could void the user's authority to operate the equipment.*

**Complies with IDA Standards DA103121**

## CE Statement

**Electromagnetic Compatibility Statement:** Meets 2014/30/EU Directive

**Low Voltage Directive:** Meets 2014/35/EU Directive

## WEEE Statement

The following information is only for EU-member States:

The mark shown below is in compliance with Waste Electrical and Electronic Equipment Directive 2012/19/EU (WEEE). The mark indicates the requirement NOT to dispose of the equipment as unsorted municipal waste, but use the return and collection systems according to local law.



## Do not stare into beam, RG2

As with any bright source, do not stare into the direct beam, RG2 IEC 62471-5:2015.

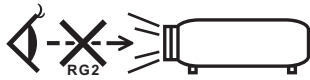

# TABLE OF CONTENTS

<b>INTRODUCTION .....</b>	<b>7</b>
<i>Package Overview.....</i>	<i>7</i>
<i>Standard accessories.....</i>	<i>7</i>
<i>Product Overview .....</i>	<i>8</i>
<i>Connections.....</i>	<i>9</i>
<i>Keypad .....</i>	<i>10</i>
<i>Remote control.....</i>	<i>11</i>
<b>SETUP AND INSTALLATION.....</b>	<b>12</b>
<i>Installing the projector .....</i>	<i>12</i>
<i>Connecting to a computer .....</i>	<i>14</i>
<i>Connecting to a DVD player.....</i>	<i>15</i>
<i>Connecting to HDBaseT and Network.....</i>	<i>16</i>
<i>Adjusting the projector image.....</i>	<i>17</i>
<i>Remote setup .....</i>	<i>18</i>
<b>USING THE PROJECTOR .....</b>	<b>20</b>
<i>Powering on / off the projector.....</i>	<i>20</i>
<i>Selecting an input source .....</i>	<i>21</i>
<i>Menu navigation and features .....</i>	<i>22</i>
<i>OSD Menu tree.....</i>	<i>23</i>
<i>Display image settings menu.....</i>	<i>30</i>
<i>Display 3D menu .....</i>	<i>32</i>
<i>Display aspect ratio menu .....</i>	<i>33</i>
<i>Display edge mask menu .....</i>	<i>36</i>
<i>Display zoom menu.....</i>	<i>36</i>
<i>Display image shift menu .....</i>	<i>36</i>
<i>Display keystone menu .....</i>	<i>36</i>
<i>Audio mute menu .....</i>	<i>37</i>
<i>Audio volume menu.....</i>	<i>37</i>
<i>Audio input menu.....</i>	<i>37</i>
<i>Audio audio/mic input function menu.....</i>	<i>37</i>
<i>Setup projection menu.....</i>	<i>38</i>
<i>Setup screen type menu.....</i>	<i>38</i>
<i>Setup power settings menu .....</i>	<i>38</i>
<i>Setup security menu.....</i>	<i>38</i>
<i>Setup HDMI CEC menu .....</i>	<i>39</i>
<i>Setup HDBaseT control settings menu .....</i>	<i>39</i>
<i>Setup options menu.....</i>	<i>40</i>
<i>Setup reset OSD menu .....</i>	<i>40</i>
<i>Network LAN menu .....</i>	<i>41</i>
<i>Network control menu.....</i>	<i>42</i>
<i>Setup network control settings menu .....</i>	<i>43</i>
<i>Info menu.....</i>	<i>47</i>

## **ADDITIONAL INFORMATION..... 48**

<i>Compatible resolutions</i> .....	48
<i>Image size and projection distance</i> .....	51
<i>Projector dimensions and ceiling mount installation</i> .....	53
<i>RS232 Commands and Protocol Function List</i> .....	54
<i>Troubleshooting</i> .....	58
<i>Warning indicators</i> .....	60
<i>Specifications</i> .....	61

# INTRODUCTION

## Package Overview

Carefully unpack and verify that you have the items listed below under standard accessories. Some of the items under optional accessories may not be available depending on the model, specification and your region of purchase. Please check with your place of purchase. Some accessories may vary from region to region.

The warranty card is only supplied in some specific regions. Please consult your dealer for detailed information.

## Standard accessories

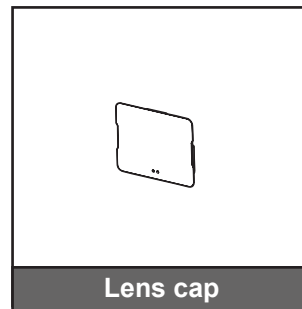
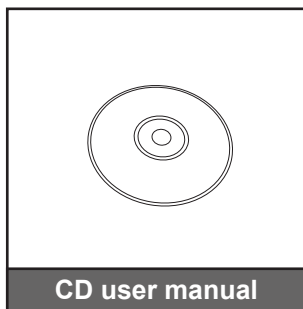
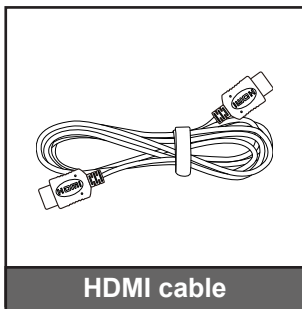
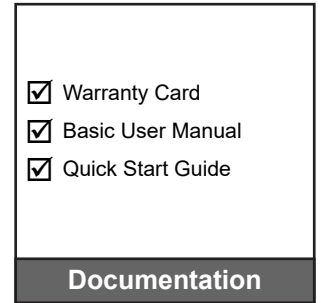
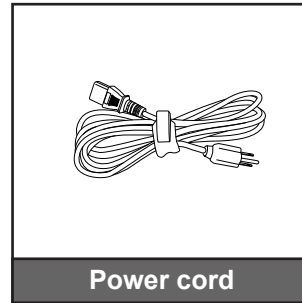
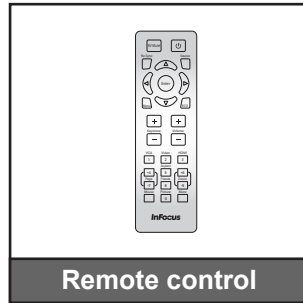
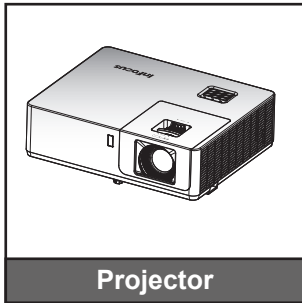

# INTRODUCTION

## Product Overview

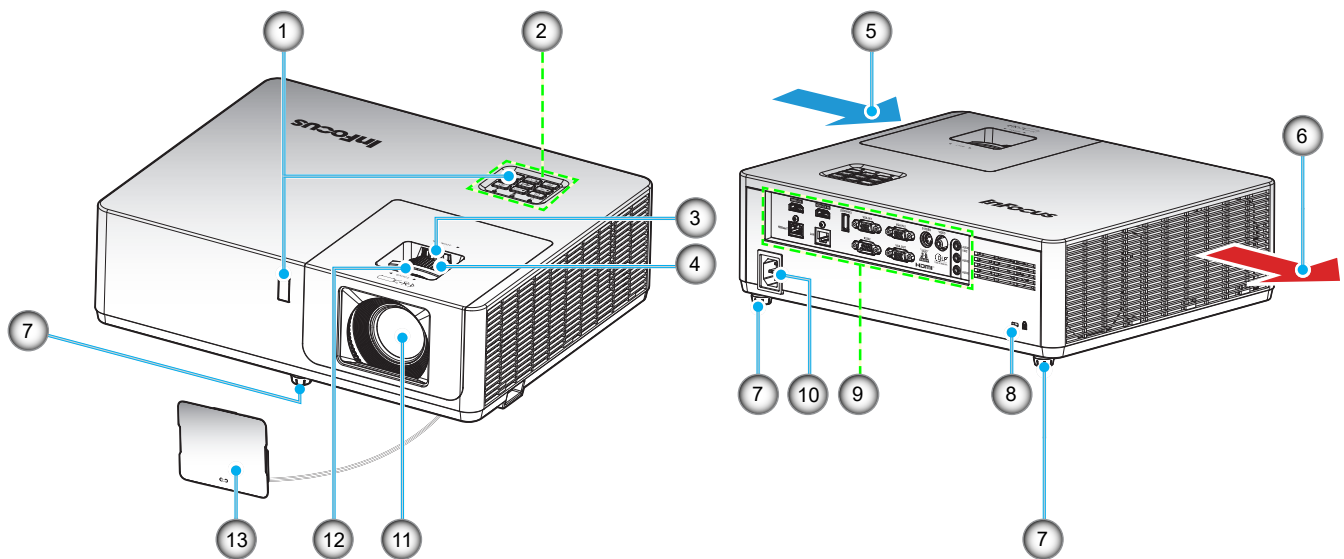

**Note:**

- Do not block projector intake and exhaust vents.
- When operating the projector in an enclosed space, allow at least 30 cm clearance around the intake and exhaust vents.

No	Item	No	Item
1.	IR Receivers	8.	Kensington™ Lock Port
2.	Keypad	9.	Input / Output
3.	Lens Shift Dial	10.	Power Socket
4.	Zoom Ring	11.	Lens
5.	Ventilation (inlet)	12.	Focus Ring
6.	Ventilation (outlet)	13.	Lens Cap
7.	Tilt-Adjustment Feet		

# INTRODUCTION

## Connections

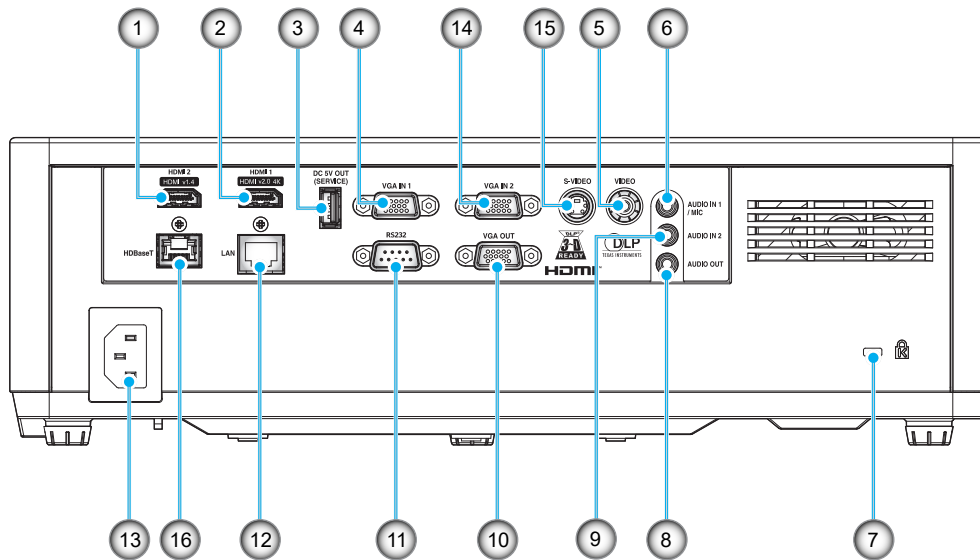

No	Item	No	Item
1.	HDMI 2 (v1.4) Connector	9.	Audio In 2 Connector
2.	HDMI 1 (v2.0)(4K) Connector	10.	VGA Out Connector
3.	USB Power Out (5V---1.5A) Connector	11.	RS232 Connector
4.	VGA In 1 Connector	12.	RJ-45 Connector
5.	Composite Connector	13.	Power Socket
6.	Audio In 1 / Microphone Connector	14.	VGA In 2 Connector
7.	Kensington™ Lock Port	15.	S-Video Connector
8.	Audio Out Connector	16.	HDBaseT Connector

# INTRODUCTION

## Keypad

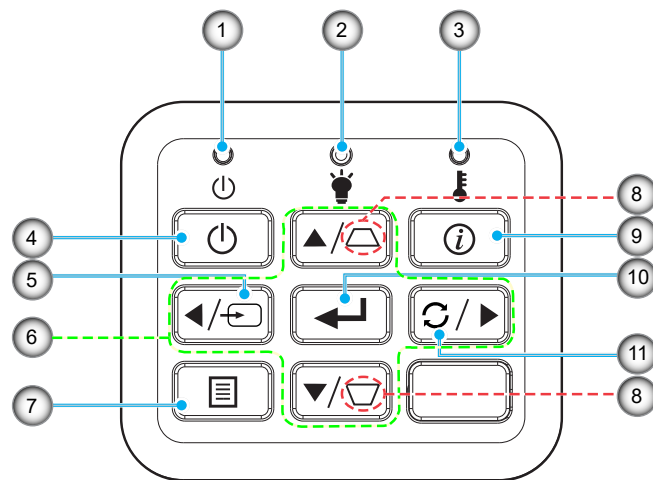

No	Item	No	Item
1.	Power LED	7.	Menu
2.	Lamp LED	8.	Keystone Correction
3.	Temp LED	9.	Information
4.	Power	10.	Enter
5.	Source	11.	Re-Sync
6.	Four directional select keys		

# INTRODUCTION

## Remote control

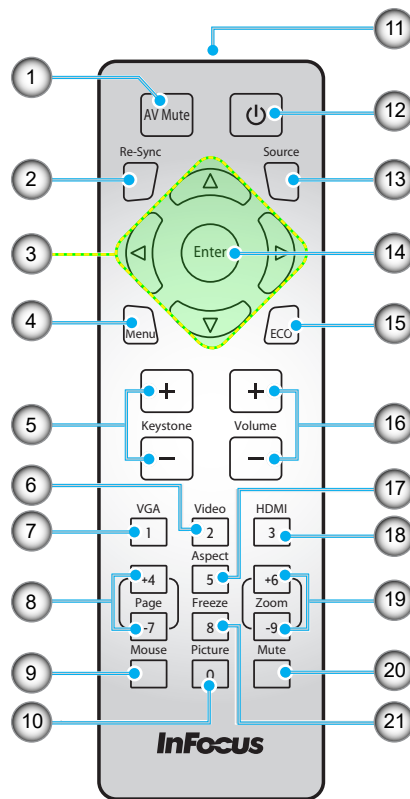

No	Item	No	Item
1.	AV Mute	12.	Power
2.	Re-Sync	13.	Source
3.	Four Directional Select Keys	14.	Enter
4.	Menu	15.	ECO
5.	Keystone +/-	16.	Volume +/-
6.	Video <b>Note:</b> Press once to select Video, twice to select S-Video.	17.	Aspect
7.	VGA <b>Note:</b> Press once to select VGA IN 1, twice to select VGA IN 2.	18.	HDMI <b>Note:</b> Press once to select HDMI 1, twice to select HDMI 2.
8.	Page +/- (not supported)	19.	Zoom +/-
9.	Mouse (not supported)	20.	Mute
10.	Picture	21.	Freeze
11.	IR LED		

**Note:** Some keys may have no function for models that do not support these features.

# SETUP AND INSTALLATION

## Installing the projector

Your projector is designed to be installed in one of four possible positions.

Your room layout or personal preference will dictate which installation location you select. Take into consideration the size and position of your screen, the location of a suitable power outlet, as well as the location and distance between the projector and the rest of your equipment.

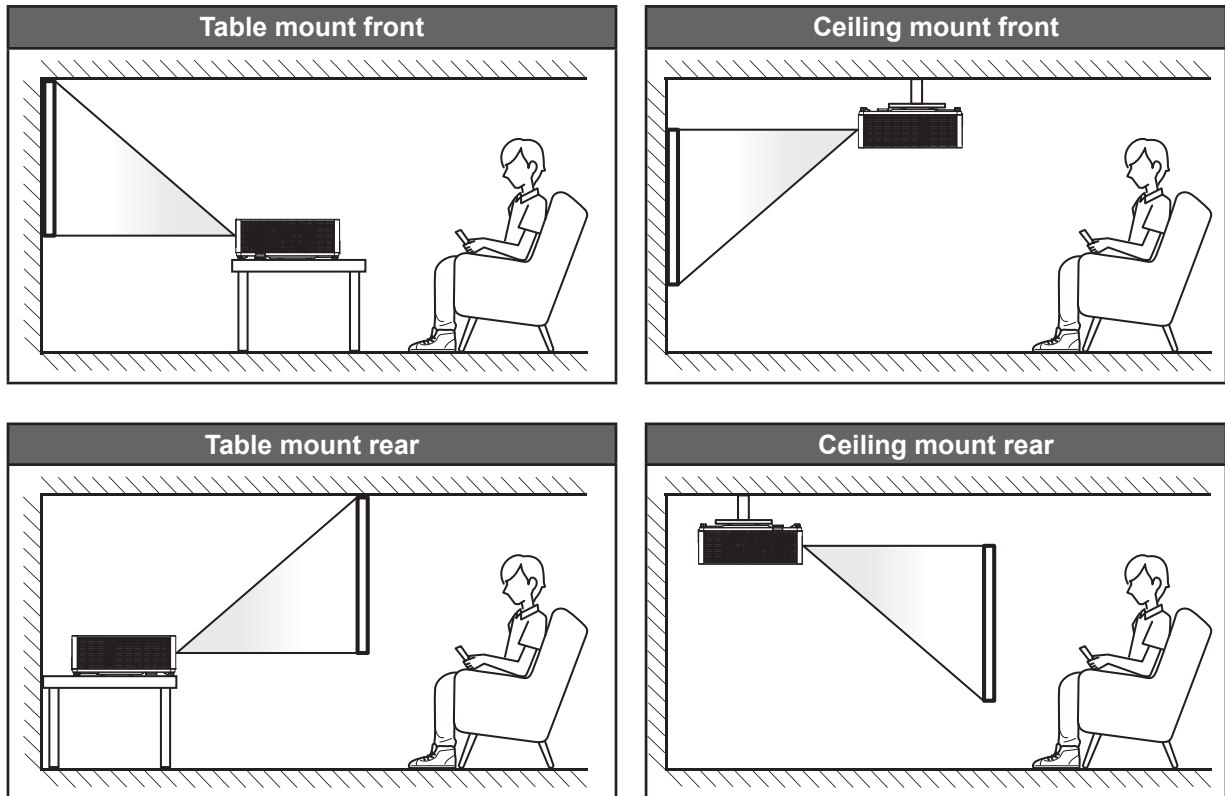

Projector should be placed flat on a surface and 90 degrees / perpendicular to the screen.

- How to determine projector location for a given screen size, please refer to distance table on pages 51-52.
- How to determine screen size for a given distance, please refer to distance table on pages 51-52.

**Note:** *The further away the projector is placed from the screen the projected image size increases and vertical offset also increases proportionally.*

### **IMPORTANT!**

*Do not operate the projector in any orientation other than table top or ceiling mount. The projector should be horizontal and not tilted either forwards/backwards or left/right. Any other orientation will invalidate the warranty and may shorten the lifetime of the projector light source or the projector itself. For non-standard installation advice please contact InFocus.*

# SETUP AND INSTALLATION

## Projector installation notice

- Place the projector in a horizontal position.  
**The tilt angle of the projector should not exceed 15 degrees**, nor should the projector be installed in any way other than the desktop and ceiling mount, otherwise laser life could decrease dramatically, and may lead to other **unpredictable damage**.



- Allow at least 30cm clearance around the intake and exhaust vents.

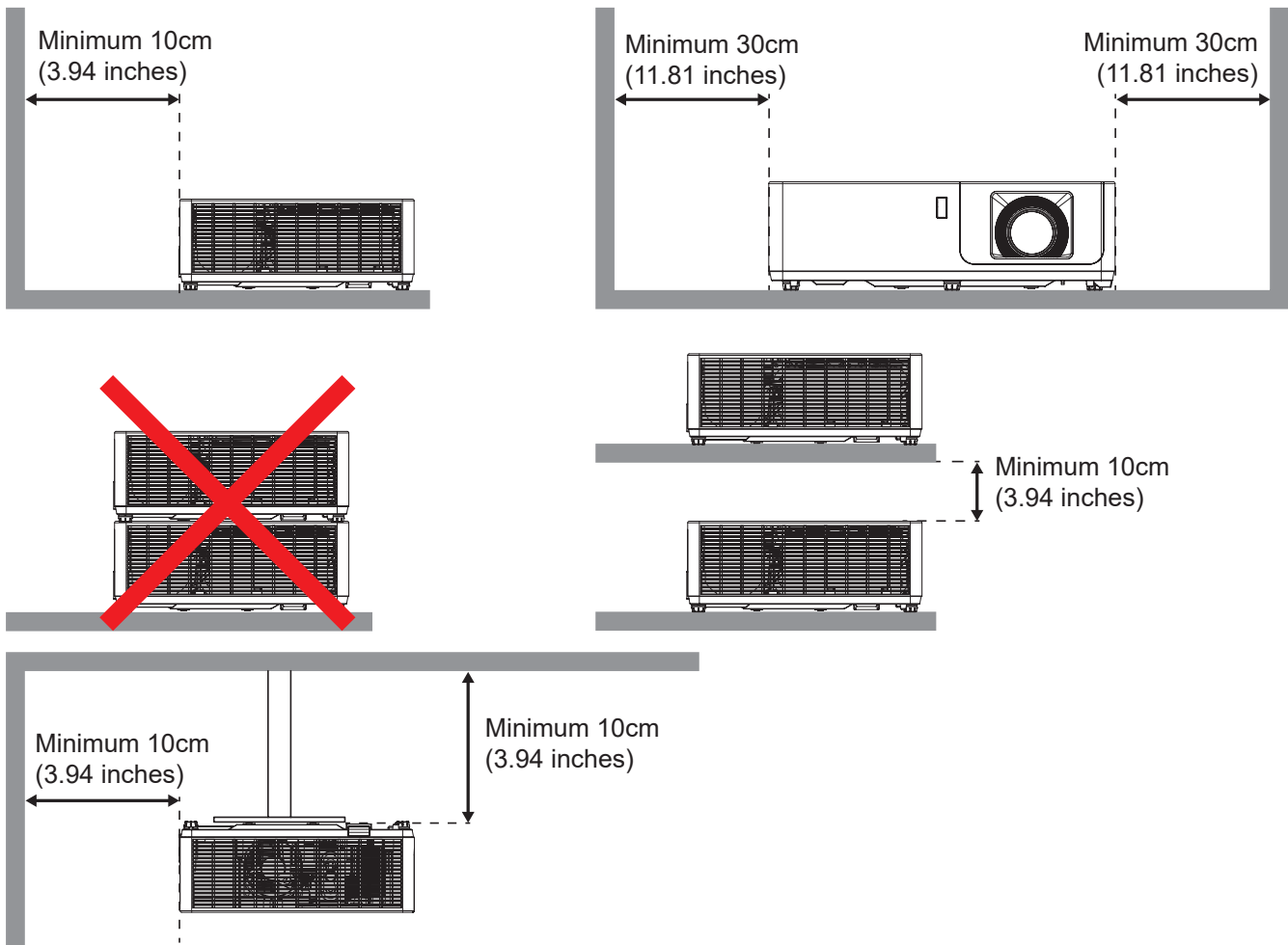

- Ensure that the intake vents do not recycle hot air from the exhaust vent.
- When operating the projector in an enclosed space, ensure that the surrounding air temperature within the enclosure does not exceed operation temperature while the projector is running, and the air intake and exhaust vents are unobstructed.
- All enclosures should pass a certified thermal evaluation to ensure that the projector does not recycle exhaust air, as this may cause the device to shutdown even if the enclosure temperature is within the acceptable operation temperature range.

# SETUP AND INSTALLATION

## Connecting to a computer

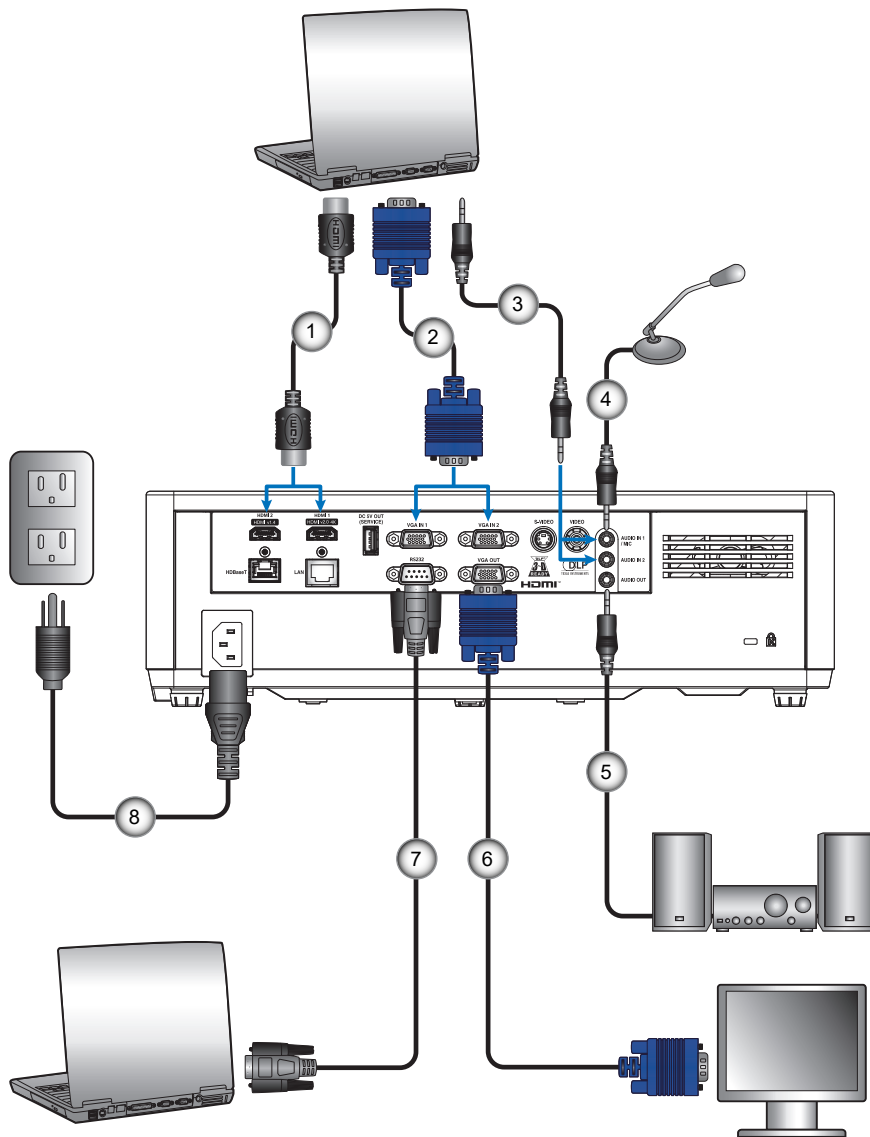

No	Item	No	Item
1.	HDMI Cable	5.	Audio Out Cable
2.	VGA In Cable	6.	VGA Out Cable
3.	Audio In Cable	7.	RS232 Cable
4.	Microphone Cable	8.	Power Cord

# SETUP AND INSTALLATION

## Connecting to a DVD player

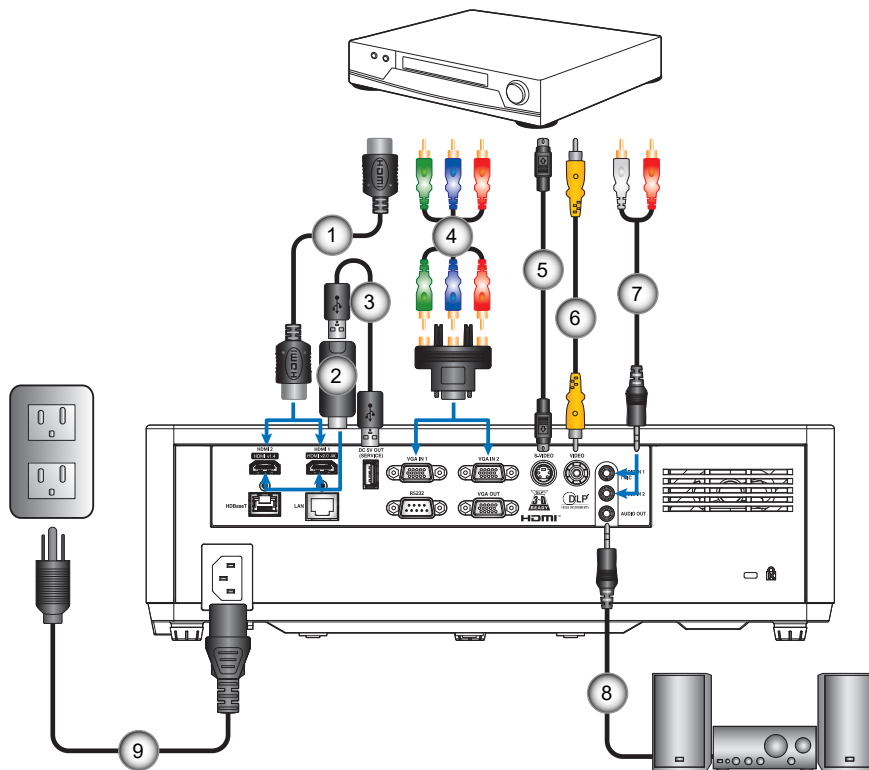

No	Item	No	Item
1.	HDMI Cable	6.	Video Cable
2.	HDMI Dongle	7.	Audio In Cable
3.	USB Power Cable	8.	Audio Out Cable
4.	RCA Component Cable	9.	Power Cord
5.	S-Video Cable		

# SETUP AND INSTALLATION

## Connecting to HDBaseT and Network

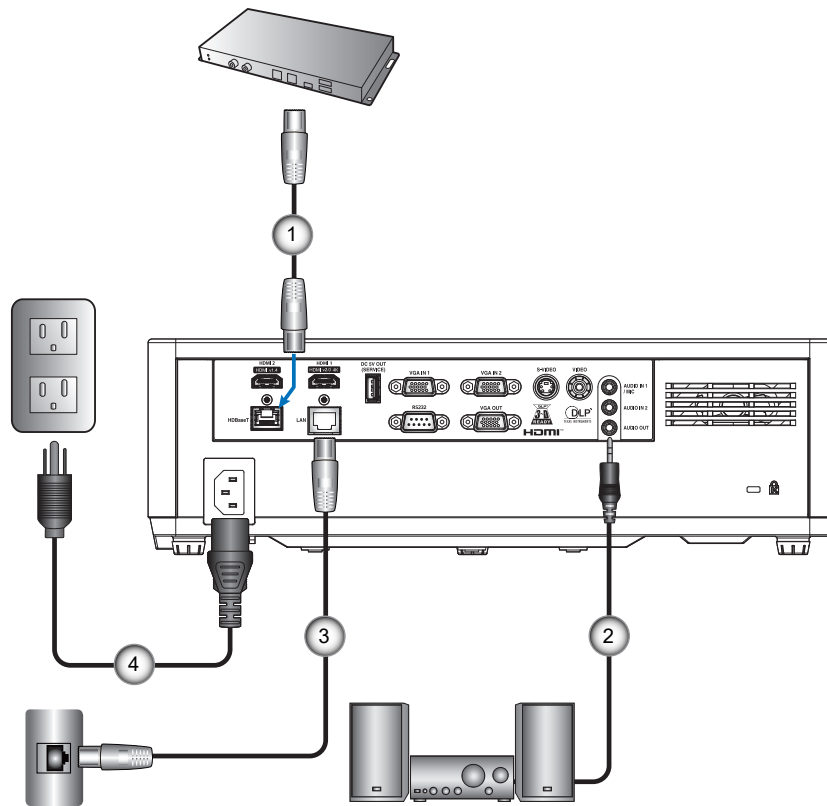

No	Item	No	Item
1.	RJ-45 Cable (Cat5 Cable)	3.	RJ-45 Cable
2.	Audio Out Cable	4.	Power Cord

# SETUP AND INSTALLATION

## Adjusting the projector image

### Image height

The projector is equipped with elevator feet for adjusting the image height.

1. Locate the adjustable foot you wish to adjust on the underside of the projector.
2. Rotate the adjustable foot clockwise or counterclockwise to raise or lower the projector.

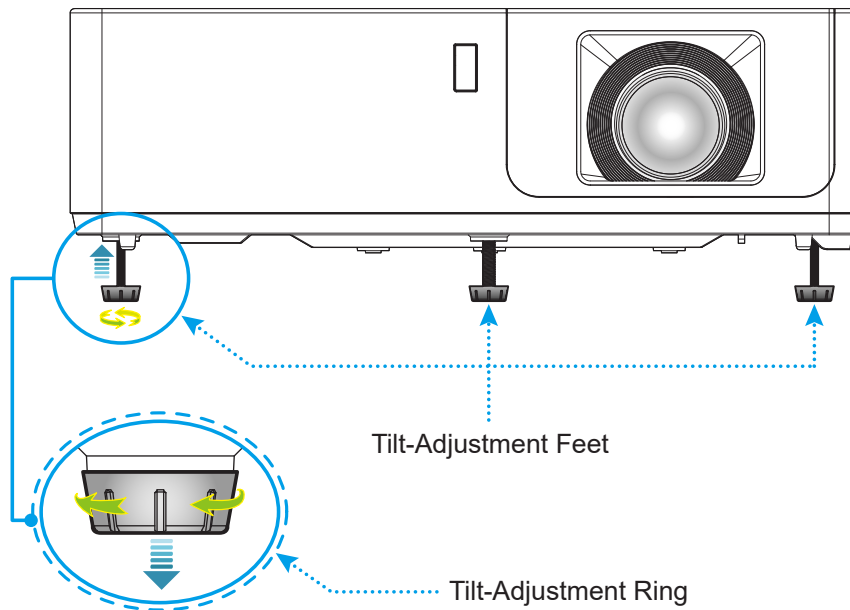

### Zoom, lens shift, and focus

- To adjust the image size, turn the zoom ring clockwise or counterclockwise to increase or decrease the projected image size.
- To adjust the image position, turn the lens shift dial clockwise or counterclockwise to adjust the position of the projected image vertically.
- To adjust the focus, turn the focus ring clockwise or counterclockwise until the image is sharp and legible.

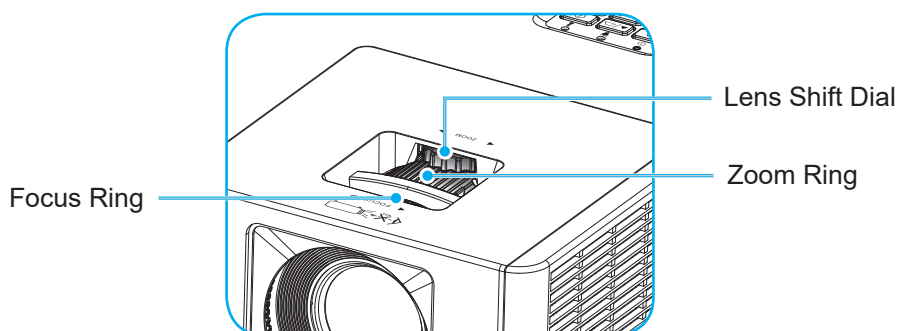

**Note:** Ensure that the projection screen is within the required distance from the projector. Please refer to "Image size and projection distance" for more information.

# SETUP AND INSTALLATION

## Remote setup

### Installing / replacing the batteries

Two AAA size batteries are required. (Not included)

1. Push the clip to release the battery cover.

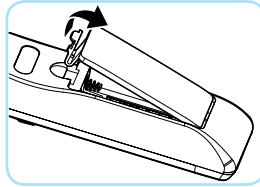

2. Install new batteries (AAA/R03). Ensure that you have the batteries' polarity (+/-) aligned correctly.

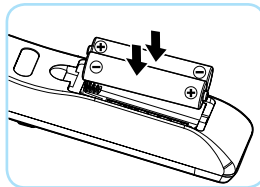

3. Close the battery cover and press it down until it clicks into place.

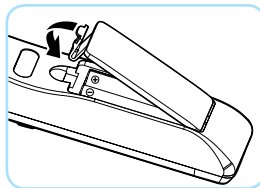

**Note:** Do not mix different types of batteries or new and old batteries.

### CAUTION

To ensure safe operation, please observe the following precautions:

- Use AAA/R03 type batteries.
- Avoid contact with water or liquid.
- Do not expose the remote control to moisture or heat.
- Do not drop the remote control.
- If the batteries have leaked in the remote control, carefully wipe the case clean and install new batteries.
- There is a risk of explosion if the batteries are replaced with the wrong type.
- Dispose of used batteries according to the instructions.
- Remove the batteries from the remote control when not using for extended periods.
- The remote control may fail to operate if the infrared remote sensor is exposed to bright sunlight or fluorescent lighting.

# SETUP AND INSTALLATION

## Effective range

Infra-Red (IR) remote control sensor is located on the top and front of the projector. Ensure to hold the remote control at an angle within 40 degrees perpendicular to the projector's IR remote control sensor to function correctly. The distance between the remote control and the sensor should not be longer than 5 meters (16.4 feet).

- Make sure that there are no obstacles between the remote control and the IR sensor on the projector that might obstruct the infra-red beam.
- Make sure the IR transmitter of the remote control is not being illuminated by sunlight or fluorescent lamps directly.
- Keep the remote control more than 2 meters away from fluorescent lamps or it may not function.
- When you aim at the screen the effective distance is 5 meters or less from the remote to the screen then back to the projector. The range will be different based on the reflectivity of the screen.

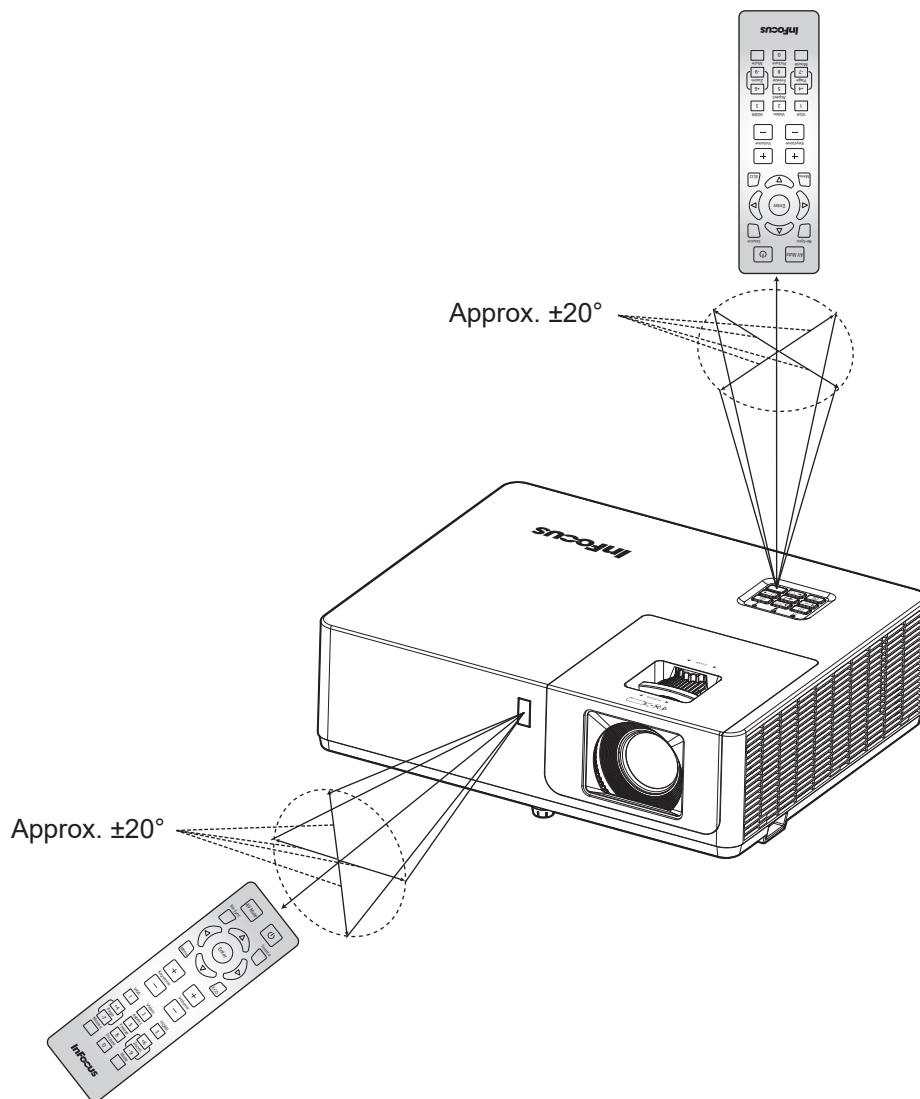

# USING THE PROJECTOR

## Powering on / off the projector

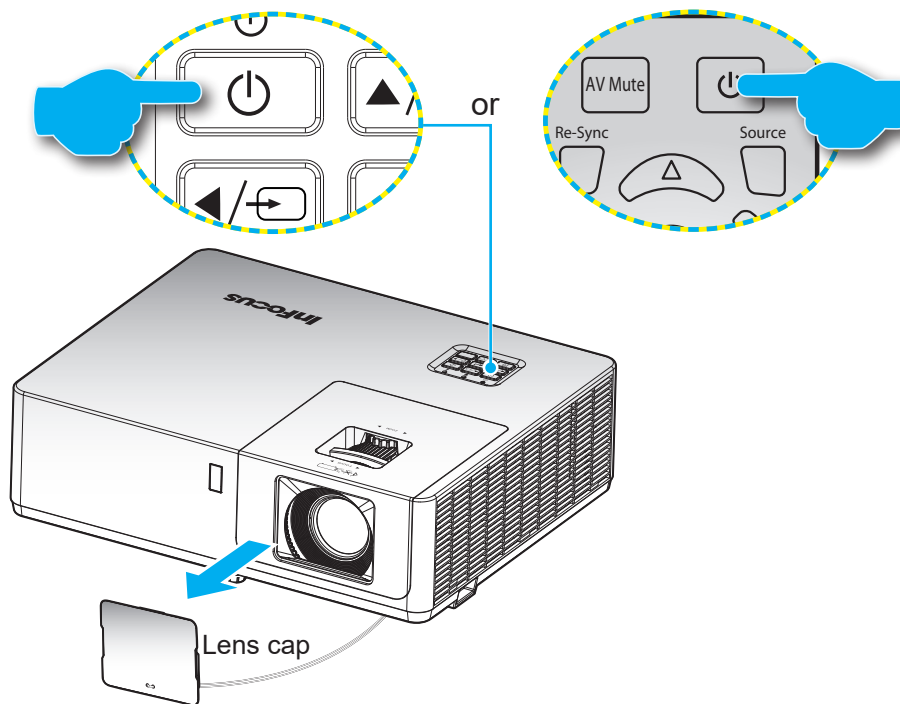

### Powering on



1. Remove the lens cap.
2. Securely connect the power lead and signal/source cable. When connected, the Power LED will turn red.
3. Turn on the projector by pressing the  button on the projector keypad or remote control.
4. A start up screen will display in approximately 10 seconds and the Power LED will turn blue.

**Note:** The first time the projector is turned on, you will be prompted to select the preferred language, projection orientation, and other settings.

### Powering off

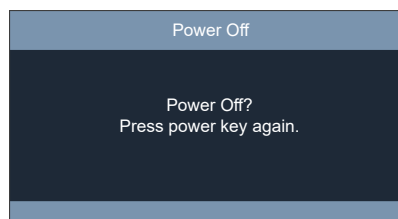
1. Turn off the projector by pressing the  button on the projector keypad or remote control.
2. The following message will be displayed:



3. Press the  button again to confirm, otherwise the message will disappear after 10 seconds. When you press the  button for the second time, the projector will shut down.
4. When the Power turns solid red, this indicates the projector has entered standby mode. If you wish to turn the projector back on, you must wait until the cooling cycle has finished and the projector has entered standby mode. When the projector is in standby mode, simply press the  button again to turn on the projector.
5. Disconnect the power lead from the electrical outlet and the projector.

**Note:** It is not recommended that the projector is turned on immediately, right after a power off procedure.

# USING THE PROJECTOR

## Selecting an input source

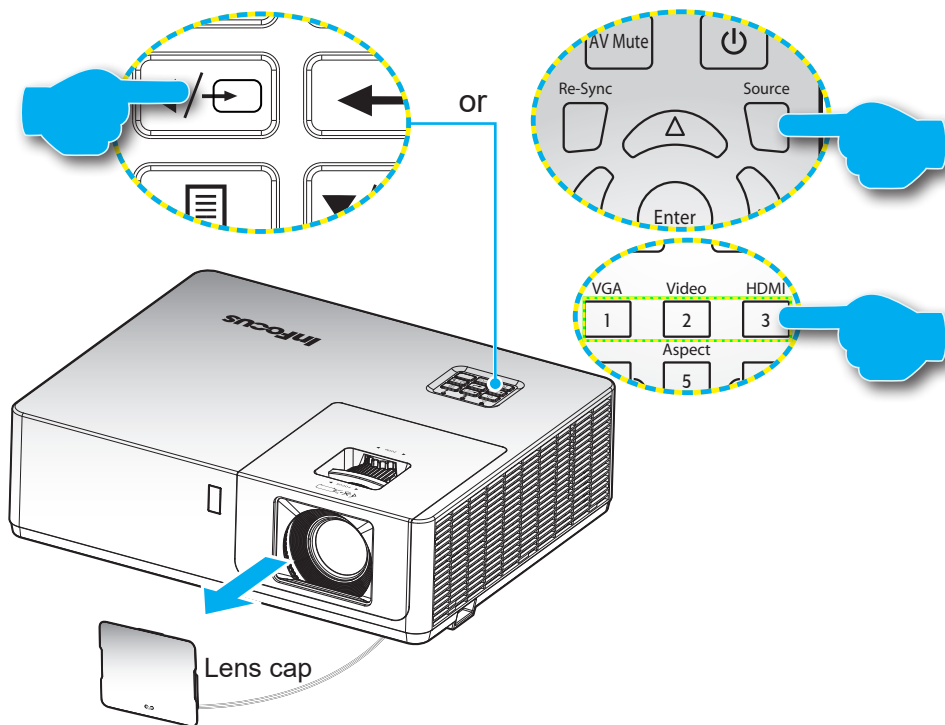

Turn on the connected source such as a computer, Blu-Ray player, HDBaseT etc. Press the  button on the keypad, the **Source** button on the remote control, or the green source buttons on the remote to select an input.



# USING THE PROJECTOR

## Menu navigation and features

The projector has multilingual on screen display menus that allow you to make image adjustments and change a variety of settings.

1. To open the OSD menu, press the  button on the projector keypad or the **Menu** button on the remote control.
2. When OSD is displayed, use **▲▼** keys to select any item in the main menu. While making a selection on a particular page, press the **←** button on the projector keypad or the **Enter** button on the remote control to enter the sub menu.
3. Use **◀▶** keys to select the desired item in the sub menu and then press the **←** or **Enter** button to view further settings. Adjust the settings by using **◀▶** keys.
4. Select the next item to be adjusted in the sub menu and adjust as described above.
5. Press press the **←** or **Enter** button to confirm, and the screen will return to the main menu.
6. To exit, press the  or **Menu** button again. The OSD menu will close and the projector will automatically save the new settings.

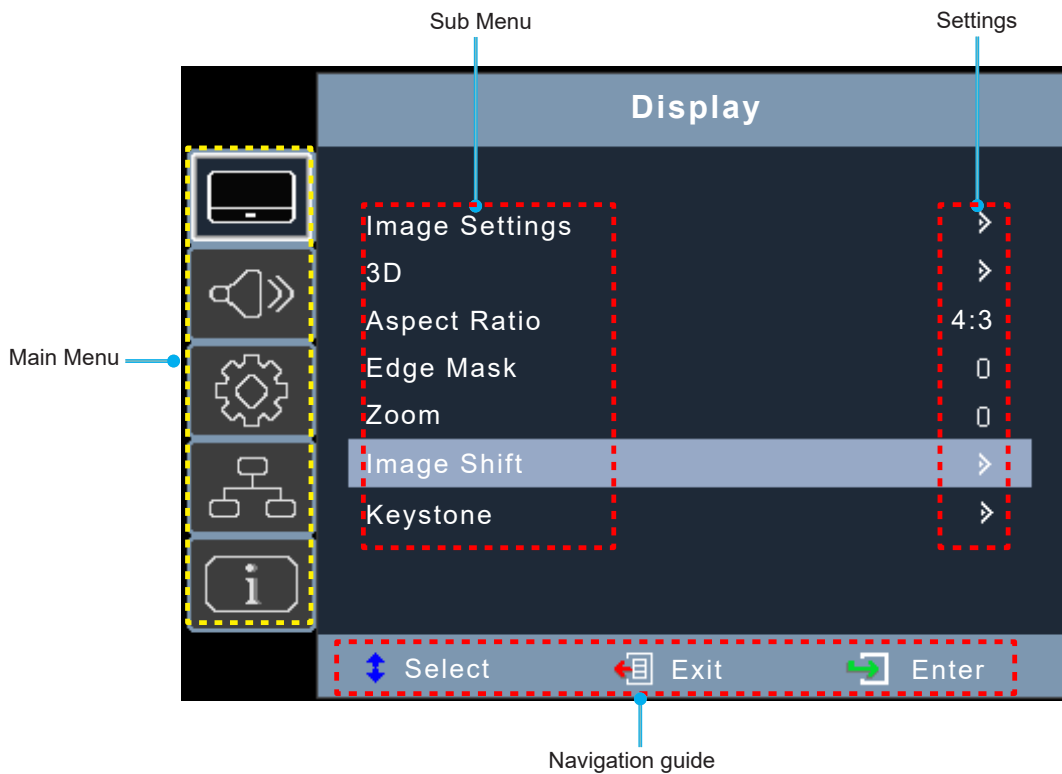

# USING THE PROJECTOR



## OSD Menu tree

Main Menu	Sub Menu	Sub Menu 2	Sub Menu 3	Sub Menu 4	Values		
Display	Image Settings	Display Mode			Presentation		
					Bright		
					HDR SIM.		
					Cinema		
					Game		
					sRGB		
					DICOM SIM.		
					User		
				3D		Off [Default]	
			Wall Color			Blackboard	
						Light Yellow	
						Light Green	
						Light Blue	
						Pink	
						Gray	
				Brightness			-50 ~ 50
				Contrast			-50 ~ 50
				Sharpness			1 ~ 15
				Color			-50 ~ 50
				Tint			-50 ~ 50
			Gamma				Film
							Video
							Graphics
							Standard(2.2)
							1.8
							2.0
							2.4
						2.6	
			Color Settings		BrilliantColor™		1 ~ 10
					Color Temperature		Warm
							Standard
							Cool
				Cold			

# USING THE PROJECTOR

Main Menu	Sub Menu	Sub Menu 2	Sub Menu 3	Sub Menu 4	Values
Display	Image Settings	Color Settings	Color Matching	Color	Red [Default]
					Green
					Blue
					Cyan
					Yellow
					Magenta
					White(*)
				Hue / R(*)	-50 ~ 50
			Saturation / G(*)	-50 ~ 50	
			Gain / B(*)	-50 ~ 50	
			Reset		
			Exit		
			RGB Gain/Bias	Red Gain	-50 ~ 50
				Green Gain	-50 ~ 50
				Blue Gain	-50 ~ 50
				Red Bias	-50 ~ 50
		Green Bias		-50 ~ 50	
		Blue Bias		-50 ~ 50	
		Reset			
		Exit			
		Color Space	Non-HDMI	Auto [Default]	
				RGB	
				YUV	
		Color Space	HDMI	Auto [Default]	
				RGB(0~255)	
				RGB(16~235)	
				YUV	
		Signal (VGA only)	Automatic	Off	
				On [Default]	
			Frequency	-10 ~ 10 (depends on signal) [Default: 0]	
			Phase	0~31 (depends on signal)	
			H. Position	-5 ~ 5 (depends on signal) [Default: 0]	
V. Position	-5 ~ 5 (depends on signal) [Default: 0]				
Brightness Mode		DynamicBlack			
		Power (Power = 100% [Default]/ 95%/ 90%/ 85%/ 80%/ 75%/ 70%/ 65%/ 60%/ 55%/ 50%)			
Reset					





# USING THE PROJECTOR

Main Menu	Sub Menu	Sub Menu 2	Sub Menu 3	Sub Menu 4	Values		
Display	3D	3D Mode			Off [Default]		
					DLP-Link		
		3D → 2D			3D [Default]		
					L		
					R		
		3D Format			Auto [Default]		
					SBS		
					Top and Bottom		
					Frame Sequential		
		3D Sync Invert			On		
				Off [Default]			
	Aspect Ratio			4:3			
				16:9 (1080p model)			
				16:10 (WUXGA model)			
				LBX			
				Native			
				Auto [Default]			
	Edge Mask			0 ~ 10 [Default: 0]			
	Zoom			-5 ~ 25 [Default: 0]			
	Image Shift	H. 			-100 ~ 100 [Default: 0]		
		V. 			-100 ~ 100 [Default: 0]		
	Keystone	Four Corners					
		H Keystone			-30 ~ 30		
V Keystone				-30 ~ 30			
Auto Keystone				Off			
Reset				On [Default]			
Audio	Mute				Off [Default]		
					On		
	Volume					0 ~ 10 [Default: 5]	
	Audio Input	HDMI1				Audio 1	
						Audio 2	
						Default [Default]	
		HDMI2					Audio 1
							Audio 2
							Default [Default]
		VGA IN 1					Audio 1 [Default]
							Audio 2
		VGA IN 2					Audio 1
							Audio 2 [Default]
S-VIDEO					Audio 1 [Default]		
					Audio 2		

# USING THE PROJECTOR

Main Menu	Sub Menu	Sub Menu 2	Sub Menu 3	Sub Menu 4	Values	
Audio	Audio Input	VIDEO			Audio 1 [Default]	
					Audio 2	
		HDBaseT			Audio 1	
					Audio 2	
					Default [Default]	
	Audio/Mic Input Function				Audio Input [Default]	
				Mic		
Setup	Projection				Front  [Default]	
					Rear 	
					Ceiling-front 	
					Ceiling-rear 	
	Screen Type				16:9	
					16:10 [Default]	
	Power Settings	Direct Power On				Off [Default]
						On
		Signal Power On				Off [Default]
						On
		Auto Power Off (min.)				0 ~ 180 (5 min increments) [Default: 20]
		Power Mode (Standby)				Active
					Eco. [Default]	
	USB Power (Standby)				Off [Default]	
					On	
	Security	Security				Off [Default]
						On
		Security Timer	Month			0 ~ 12 [Default: 0]
			Day			0 ~ 30 [Default: 0]
			Hour			0 ~ 24 [Default: 0]
	Change Password				[Default: 1234]	
	HDMI CEC	HDMI CEC				Off [Default]
						On
	HDBaseT Control	Ethernet				Off [Default]
						On
		RS232				Off [Default]
						On
HDBaseT Mode					HDBaseT [Default]	
					Auto	

# USING THE PROJECTOR

Main Menu	Sub Menu	Sub Menu 2	Sub Menu 3	Sub Menu 4	Values		
Setup	Options	Language			English [Default]		
					Deutsch		
					Français		
					Italiano		
					Español		
					Português		
					Polski		
					Nederlands		
					Svenska		
					Norsk		
					Suomi		
					ελληνικά		
					繁體中文		
					简体中文		
					日本語		
					<b>한국어</b>		
					Русский		
					Magyar		
					Čeština		
					عربي		
				ไทย			
				Türkçe			
				فارسی			
				Tiếng Việt			
				Bahasa Indonesia			
				Română			
				Slovenčina			
			Closed Caption			CC1	
						CC2	
						Off [Default]	
			Menu Settings	Menu Location			Top-Left 
							Top-Right 
							Center  [Default]
							Bottom-Left 
					Bottom-Right 		
	Menu Timer			Off			
				5 sec			
				10 sec [Default]			
	Auto Source			Off [Default]			
				On			

# USING THE PROJECTOR

Main Menu	Sub Menu	Sub Menu 2	Sub Menu 3	Sub Menu 4	Values	
Setup	Options	Input Source			HDMI 1	
					HDMI 2	
					VGA IN 1 [Default]	
					VGA IN 2	
					Video	
					S-Video	
					HDBaseT	
			High Altitude			Off [Default]
					On	
			Logo			Default [Default]
					Neutral	
			Background Color			Black [Default]
						Blue
						Red
					Green	
				Gray		
				Logo		
	Reset	Reset to Default				
Network	LAN	Network Status			Disconnect	
					Connect <b>Note:</b> By default the network status is displayed only.	
		MAC Address			AA : BB : CC : DD : EE : FF <b>Note:</b> By default the network status is displayed only.	
		DHCP			Off [Default]	
					On	
		IP Address			192.168.0.100 [Default]	
		Subnet Mask			255.255.255.0 [Default]	
		Gateway			192.168.0.254 [Default]	
		DNS			192.168.0.51 [Default]	
	Reset					
	Control	HTTP			Off	
					On [Default] <b>Note:</b> Webpage control.	

# USING THE PROJECTOR

Main Menu	Sub Menu	Sub Menu 2	Sub Menu 3	Sub Menu 4	Values	
Info	Serial Number					
	Source					
	Resolution					
	Refresh Rate					
	Display Mode					
	Power Mode (Standby)					
	Light Source Hours					
	Network Status					
	IP Address					
	Brightness Mode					
	FW Version	System				
		LAN				
MCU						

**Note:** Functions vary depending on model definition.

# USING THE PROJECTOR

## *Display menu*

### Display image settings menu

#### Display Mode

There are many factory presets optimized for various types of images.

- **Presentation:** This mode is suitable for showing in front of public in connection to the PC.
- **Bright:** Maximum brightness from any source.
- **HDR SIM.:** Decodes and displays High Dynamic Range (HDR) content for the deepest blacks, brightest whites, and vivid cinematic color using REC.2020 color gamut. This mode can be selected to enhance non-HDR content with simulated High Dynamic Range (HDR).
- **Cinema:** Provides the best colors for watching movies.
- **Game:** Select this mode to increase brightness and decrease response time for enjoying video games.
- **sRGB:** Standardized accurate color.
- **DICOM SIM.:** For viewing monochrome medical images such as X-rays, MRIs, etc.
- **User:** Saved user's settings.
- **3D:** To experience 3D you need DLP-Link 3D glasses and video source capable of sending 3D content.

#### Wall Color

Use this function to obtain an optimized screen image according to the wall color. Select between off, blackboard, light yellow, light green, light blue, pink, and gray.

#### Brightness

Adjust the brightness of the image.

#### Contrast

The contrast controls the degree of difference between the lightest and darkest parts of the picture.

#### Sharpness

Adjust the Sharpness of a Video or S-Video source.

#### Color

Adjust a Video or S-Video source from black and white to fully saturated color.

#### Tint

Adjust the color balance of a Video or S-Video source between red and green.

#### Gamma

Set up gamma curve type. After the initial setup and fine tuning is completed, utilize the Gamma Adjustment steps to optimize your image output.

- **Film:** For home theater.
- **Video:** For video or TV source.
- **Graphics:** For PC / Photo source.
- **Standard (2.2):** For standardized setting.
- **1.8 / 2.0 / 2.4 / 2.6:** For specific PC / Photo sources.

# USING THE PROJECTOR

## Note:

- These options are only available if the 3D mode function is disabled, the **Wall Color** setting is not set to **Blackboard**, and the **Display Mode** setting is not set to **DICOM SIM.** or **HDR SIM.**
- In 3D mode, user can only select **3D** for **Gamma** setting.
- If the **Wall Color** setting is set to **Blackboard**, user can only select **Blackboard** for **Gamma** setting.
- If the **Display Mode** setting is set to **DICOM SIM.**, user can only select **DICOM SIM.** for **Gamma** setting.
- If the **Display Mode** setting is set to **HDR SIM.**, user can only select **HDR SIM.** for **Gamma** setting.

## Color Settings

Configure the color settings.

- **BrilliantColor™**: This function utilizes a new color-processing algorithm and enhancements to enable higher brightness while providing true, more vibrant colors.
- **Color Temperature**: Select a color temperature from Warm, Standard, Cool, or Cold.
- **Color Matching**: Select the following options:
  - Color: Select the color to adjust: red, green, blue, cyan, yellow, magenta, or white.
  - Hue / R(red)\*: Adjust the hue (color) of the color selected in the **Color** setting.  
**Note:** \*If the selected color is **White**, you will adjust the red level.
  - Saturation / G(green)\*: Adjust the saturation (offset) of the color selected in the **Color** setting.  
**Note:** \*If the selected color is **White** you will adjust the green level.
  - Gain / B(blue)\*: Adjust the gain (level) of the color selected in the **Color** setting.  
**Note:** \*If the selected color is **White** you will adjust the blue level.
  - Reset: Return the factory default settings for color matching.
  - Exit: Exit the “Color Matching” menu.
- **RGB Gain/Bias**: This function adjusts the gain and bias of individual colors.
  - Reset: Return the factory default settings for RGB gain/bias.
  - Exit: Exit the “RGB Gain/Bias” menu.
- **Color Space (non-HDMI input only)**: Select an appropriate color matrix type from the following: AUTO, RGB, or YUV.
- **Color Space (HDMI input only)**: select an appropriate color matrix type from the following: Auto, RGB (0-255), RGB (16-235), and YUV.

## Signal

Adjust the signal synchronization settings for VGA/Component sources.

- **Automatic**: Configure automatically the signal (the frequency and phase items are grayed out). If automatic is disabled, the frequency and phase items will appear for tuning and saving the settings.
- **Frequency**: Change the display data frequency to match the frequency of your computer’s graphic card. Use this function only if the image appears to flicker vertically.
- **Phase**: Synchronize the signal timing of the display with the graphic card. If the image appears to be unstable or flickers, use this function to correct it.
- **H. Position**: Adjust the horizontal position of the image.
- **V. Position**: Adjust the vertical position of the image.

# USING THE PROJECTOR

## **Brightness Mode**

Adjust the brightness mode settings.

- **DynamicBlack:** Automatically adjusts the brightness based on the source signal for optimum contrast performance.
- **Power:** Select the power percentage to adjust the overall brightness.

## **Reset**

Return the factory default settings for color settings.

## **Display 3D menu**

### **Note:**

- *This projector is a 3D ready projector with DLP-Link 3D solution.*
- *Please make sure your 3D glasses are use for DLP-Link 3D before enjoy your video.*
- *Supports Frame Sequential (page flip), Side-by-Side (SDS) and Top Bottom 3D video formats.*
- *To enable 3D mode, the input frame rate should be set to 60Hz only, lower or higher frame rate is not supported.*
- *To reach the best performance, resolution 1920x1080 is recommended, please be noted that 4K (3840x2160) resolution is not supported in 3D mode.*
- *3D from a Blu-Ray 3D is detected and displayed automatically.*

## **3D Mode**

Use this option to disable the 3D function or select the appropriate the 3D function.

- **Off:** Select “Off” to turn off 3D mode.
- **DLP-Link:** Select to use optimized settings for DLP 3D Glasses.

**Note:** *If 2D and 3D sources are both connected, turn off 3D when selecting the 2D source.*

## **3D → 2D**

Use this option to specify how the 3D content should appear on the screen.

- **3D:** Display 3D signal.
- **L (Left):** Display the left frame of 3D content.
- **R (Right):** Display the right frame of 3D content.

## **3D Format**

Use this option to select the appropriate 3D format content.

- **Auto:** When a 3D identification signal is detected, the 3D format is selected automatically.
- **SBS:** Display 3D signal in “Side-by-Side” format.
- **Top and Bottom:** Display 3D signal in “Top and Bottom” format.
- **Frame Sequential:** Display 3D signal in “Frame Sequential” format.

## **3D Sync Invert**

Select whether the right or left eye of the glasses synchronizes first.

# USING THE PROJECTOR

## Display aspect ratio menu

### Aspect Ratio

Select the aspect ratio of the displayed image between the following options:

- **4:3:** This format is for 4:3 input sources.
- **16:9:** This format is for 16:9 input sources, like HDTV and DVD enhanced for Wide screen TV.
- **16:10** (for WUXGA model only): This format is for 16:10 input sources, like widescreen laptops.
- **LBX:** This format is for non-16x9, letterbox source and if you use external 16x9 lens to display 2.35:1 aspect ratio in full resolution.
- **Native:** This format displays the original image without any scaling.
- **Auto:** Automatically selects the appropriate display format.

### Note:

- *Detailed information about LBX mode:*
  - *Some Letter-Box Format DVDs are not enhanced for 16x9 TVs. In this situation, the image will not look right when displaying the image in 16:9 mode. In this situation, please try to use the 4:3 mode to view the DVD. If the content is not 4:3, there will be black bars around the image in 16:9 display. For this type of content, you can use LBX mode to fill the image on the 16:9 display.*
  - *When using an external anamorphic lens, the LBX mode allows you to watch 2.35:1 content, including Anamorphic DVD and HDTV film sources. In this case there are no black bars, light source power and vertical resolution are fully utilized.*

### 1080p scaling table:

16:9 screen	480i/p	576i/p	1080i/p	720p	PC
4x3	Scale to 1440x1080.				
16x9	Scale to 1920x1080.				
LBX	Scale to 1920x1440, then get the central 1920x1080 image to display.				
Native mode	- 1:1 mapping centered. - No scaling will be made; the image is displayed with the resolution based on input source.				
Auto	- If auto format is selected, the screen type will automatically become 16:9 (1920x1080). - If source is 4:3, the screen type will be scaled to 1440 x1080. - If source is 16:9, the screen type will be scaled to 1920x1080. - If source is 16:10, the screen type will be scaled to 1920x1200 and cut 1920x1080 area to display.				

# USING THE PROJECTOR

## 1080p auto mapping rule:

Auto	Input resolution		Auto/Scale	
	H-resolution	V-resolution	1920	1080
4:3	640	480	1440	1080
	800	600	1440	1080
	1024	768	1440	1080
	1280	1024	1440	1080
	1400	1050	1440	1080
	1600	1200	1440	1080
Wide Laptop	1280	720	1920	1080
	1280	768	1800	1080
	1280	800	1728	1080
SDTV	720	576	1350	1080
	720	480	1620	1080
HDTV	1280	720	1920	1080
	1920	1080	1920	1080

## WUXGA scaling table for 1920 x 1200 DMD (screen type 16:10):

### Note:

- Supported screen type 16:10 (1920 x 1200), 16:9 (1920x1080).
- When screen type is 16:9, the 16x10 format becomes unavailable.
- When screen type is 16:10, the 16x9 format becomes unavailable.
- When **Auto** is selected the aspect ratio is automatically selected based on the video source.

16 : 10 screen	480i/p	576i/p	1080i/p	720p	PC
4x3	Scale to 1600x1200.				
16x9	Scale to 1920x1080.				
16x10	Scale to 1920x1200.				
LBX	Scale to 1920x1440, then get the central 1920x1200 image to display.				
Native mode	- 1:1 mapping centered. - No scaling will be made; the image is displayed with the resolution based on input source.				
Auto	- If this format is selected, the screen type will automatically become 16:10 (1920x1200). - If source is 4:3, the screen type will be scaled to 1600x1200. - If source is 16:9, the screen type will be scaled to 1920x1080. - If source is 16:10, the screen type will be scaled to 1920x1200.				

# USING THE PROJECTOR

## WUXGA auto mapping rule (screen type 16:10):

Auto	Input resolution		Auto/Scale	
	H-resolution	V-resolution	1920	1200
4:3	640	480	1600	1200
	800	600	1600	1200
	1024	768	1600	1200
	1280	1024	1600	1200
	1400	1050	1600	1200
	1600	1200	1600	1200
Wide Laptop	1280	720	1920	1080
	1280	768	1920	1152
	1280	800	1920	1200
SDTV	720	576	1350	1080
	720	480	1620	1080
HDTV	1280	720	1920	1080
	1920	1080	1920	1080

## WUXGA scaling table (screen type 16:9):

16 : 9 screen	480i/p	576i/p	1080i/p	720p	PC
4x3	Scale to 1440x1080.				
16x9	Scale to 1920x1080.				
LBX	Scale to 1920x1440, then get the central 1920x1080 image to display.				
Native mode	<ul style="list-style-type: none"> <li>- 1:1 mapping centered.</li> <li>- No scaling will be made; the image is displayed with the resolution based on input source.</li> </ul>				
Auto	<ul style="list-style-type: none"> <li>- If this format is selected, the screen type will automatically become 16:9 (1920x1080).</li> <li>- If source is 4:3, the screen type will be scaled to 1440x1080.</li> <li>- If source is 16:9, the screen type will be scaled to 1920x1080.</li> <li>- If source is 16:10, the screen type will be scaled to 1920x1200 and cut 1920x1080 area to display.</li> </ul>				

## WUXGA auto mapping rule (screen type 16:9):

Auto	Input resolution		Auto/Scale	
	H-resolution	V-resolution	1920	1080
4:3	640	480	1440	1080
	800	600	1440	1080
	1024	768	1440	1080
	1280	1024	1440	1080
	1400	1050	1440	1080
	1600	1200	1440	1080
Wide Laptop	1280	720	1920	1080
	1280	768	1800	1080
	1280	800	1728	1080
SDTV	720	576	1350	1080
	720	480	1620	1080

# USING THE PROJECTOR

Auto	Input resolution		Auto/Scale	
	H-resolution	V-resolution	1920	1080
HDTV	1280	720	1920	1080
	1920	1080	1920	1080

## Display edge mask menu

### Edge Mask

Use this function to remove the video encoding noise on the edge of video source.

**Note:** *This function is grayed out if the input source is VIDEO or S-VIDEO and the resolution is 1080P or WUXGA.*

## Display zoom menu

### Zoom

Use to reduce or magnify an image on the projection screen.

**Note:** *Pan functions are not supported.*

## Display image shift menu

### Image Shift

Adjust the projected image position horizontally (H.) or vertically (V.).

## Display keystone menu

### Four Corners

Allow the image to be shaped to fit an area defined by changing the x,y position of the four corners.

### H Keystone

Adjust horizontal image distortion making the image more square. Horizontal keystone is used to correct a keystone image shape in which the left and right borders of the image are unequal in length.

### V Keystone

Adjust vertical image distortion making the image more square. Vertical keystone is used to correct a keystone image shape in which the top and bottom borders of the image are unequal in length.

### Auto Keystone

Correct keystone digitally to fit the projected image on the area on which you are projecting.

#### **Note:**

- *The image size will reduce slightly when adjusting the horizontal and vertical keystone.*
- *When **Auto Keystone** is enabled the **Four Corner Adjustment** function will be disabled.*

### Reset

Return the factory default settings for keystone settings.

# USING THE PROJECTOR

## *Audio menu*

### Audio mute menu

#### Mute

Use this option to temporarily turn off the sound.

- **On:** Choose “On” to turn mute on.
- **Off:** Choose “Off” to turn mute off.

#### **Note:**

- “Mute” function affects both internal and external speaker volume.
- When “Mute” is On, you will see the associated icon on top-right side of the screen.

### Audio volume menu

#### Volume

Adjust the speaker or microphone volume level.

### Audio input menu

#### Audio Input

Select the audio input port for the video sources as follows:

- **HDMI1:** Audio 1, Audio 2, or Default.
- **HDMI2:** Audio 1, Audio 2, or Default.
- **VGA IN 1:** Audio 1 and Audio 2.
- **VGA IN 2:** Audio 1 and Audio 2.
- **S-VIDEO:** Audio 1 and Audio 2.
- **VIDEO:** Audio 1 and Audio 2.
- **HDBaseT:** Audio 1, Audio 2, or Default.

### Audio audio/mic input function menu

#### Audio/Mic Input Function

Configure the audio input source setting.

- **Audio Input:** Audio In 1 configured for line level audio sources.
- **Mic:** Audio In 1 configured for microphone. Condenser microphone is recommended.

# USING THE PROJECTOR

## Setup menu

### Setup projection menu

#### Projection

Select the preferred projection orientation: Front, Rear, Ceiling-front, Ceiling-rear.

### Setup screen type menu

#### Screen Type (for WUXGA model only)

Choose the screen type from 16:9 and 16:10.

### Setup power settings menu

#### Direct Power On

Choose “On” to activate Direct Power mode. The projector will automatically power on when AC power is supplied, without pressing the “Power” key on the projector keypad or on the remote control.

#### Signal Power On

Choose “On” to activate Signal Power mode. The projector will automatically power on when a signal is detected, without pressing the “Power” key on the projector Keypad or on the remote control.

**Note:** Only supported on HDMI 1, HDMI 2 and VGA In 1 Connector.

#### Auto Power Off (min.)

Sets the countdown timer interval. The countdown timer will start, when there is no signal being sent to the projector. The projector will automatically power off when the countdown has finished (in minutes).

#### Power Mode (Standby)

Set the power mode setting.

- **Active:** Select for normal standby (<2W).  
**Note:** LAN and VGA out functions are On.
- **Eco.:** Reduce power dissipation (<0.5W).  
**Note:** LAN and VGA out functions are not available.

#### USB Power (Standby)

Enable or disable the USB power function when the projector is in standby mode.

**Note:** This function is grayed out if the “Power Mode (Standby)” is set to “Eco.”.

### Setup security menu

#### Security

Enable this function to prompt for a password before using the projector.

- **On:** Choose “On” to use security verification when turning on the projector.
- **Off:** Choose “Off” to be able to switch on the projector without password verification.

#### Security Timer

Opens the Month/Day/Hour function to set the number of hours the projector can be used. Once the set time is elapsed the password will be required to use the projector.

# USING THE PROJECTOR

## Change Password

Sets or modifies the security password.

**Note:** Password default value is “1234” (first time).

## Setup HDMI CEC menu

### **Note:**

- When you connect HDMI CEC-compatible devices to the projector with HDMI cables, you can control them on the same power on or power off status using the HDMI Link control feature in the projector’s OSD. This lets one device or multiple devices in a group power on or power off via HDMI Link Feature in a typical configuration, your DVD player may be connected to the projector through an amplifier or home theater system.

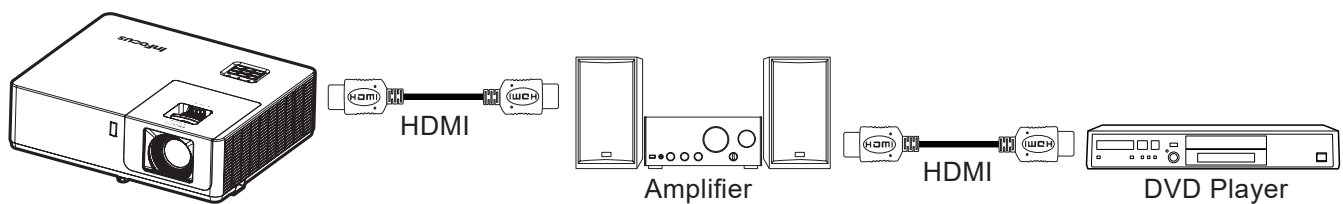

## HDMI CEC

Default is Off. Select “On” to enable HDMI CEC function.

## Setup HDBaseT control settings menu

### Ethernet

Enable or disable the Ethernet feature.

- **On:** Choose “On” to enable HDBaseT port connection and disable LAN port connection.
- **Off:** Choose “Off” to use LAN port connection.

### RS232

Enable or disable the RS232 feature.

- **On:** Choose “On” to enable HDBaseT port connection and disable RS232 port connection.
- **Off:** Choose “Off” to use RS232 port connection.

### HDBaseT Mode

Set the HDBaseT mode setting:

- **Auto:** The HDBaseT Rx of projector will automatically switch between HDBaseT mode/ Lower power mode/Fallback mode when it detects a signal from the HDBaseT port.
- **HDBaseT:** The source must be selected manually.

# USING THE PROJECTOR

## Setup options menu

### Language

Select the multilingual OSD menu between English, German, French, Italian, Spanish, Portuguese, Polish, Dutch, Swedish, Norwegian, Finnish, Greek, traditional Chinese, simplified Chinese, Japanese, Korean, Russian, Hungarian, Czechoslovak, Arabic, Thai, Turkish, Farsi, Vietnamese, Indonesian, Romanian, and Slovakian.

### Closed Caption

Closed Caption is a text version of the program sound or other information displayed on the screen. If the input signal contains closed captions, you can turn on the feature and watch the channels. The available options include "Off", "CC1", and "CC2".

### Menu Settings

Set the menu location on the screen and configure menu timer settings.

- **Menu Location:** Select the menu location on the display screen.
- **Menu Timer:** Set the duration the OSD menu stays visible on the screen.

### Auto Source

Choose this option to let the projector automatically find an available input source.

- **Off:** The projector will only search the current input selection. Press the **Source** button on the keypad or on the remote to display a list of sources.
- **On:** The projector automatically finds an available input source. Press the **Source** button on the keypad or on the remote to automatically detect the next source.

### Input Source

Select the input source between HDMI1, HDMI2, VGA IN 1, VGA IN 2, Video, S-Video, and HDBaseT.

### High Altitude

When "On" is selected, the fans will spin faster. This feature is useful in high altitude areas where the air is thin.

### Logo

Use this function to set the desired startup screen. If changes are made, they will take effect the next time the projector is powered on.

- **Default:** The default startup screen.
- **Neutral:** Logo is not displayed on startup screen.

### Background Color

Use this function to display a black, blue, red, green, gray color, or logo screen when no signal is available.

## Setup reset OSD menu

### Reset to Default

Return all settings to factory default except for the network settings.

# USING THE PROJECTOR

## *Network menu*

### **Network LAN menu**

#### **Network Status**

Display the network connection status (read-only).

#### **MAC Address**

Display the MAC address (read-only).

#### **DHCP**

Use this option to enable or disable the DHCP function.

- **Off:** To assign IP, subnet mask, gateway, and DNS configuration manually.
- **On:** Projector will obtain an IP address automatically from your network.

**Note:** *The entered values will be applied when exiting the menu.*

#### **IP Address**

Display the IP address.

#### **Subnet Mask**

Display subnet mask number.

#### **Gateway**

Display the default gateway of the network connected to the projector.

#### **DNS**

Display the DNS number.

### **How to use web browser to control your projector**

1. Turn "On" the DHCP option on projector to allow a DHCP server to automatically assign an IP address.
2. Open the web browser in your PC and type in the projector's IP address ("Network > LAN > IP Address").
3. Enter the user name and password, and click "Login".  
The projector's configuration web interface opens.

**Note:**

- *The default user name and password is "admin".*
- *The steps in this section are based on the Windows 7 operating system.*

# USING THE PROJECTOR

## Making a direct connection from your computer to the projector\*

1. Turn “Off” the DHCP option on the projector.
2. Configure the IP address, Subnet Mask, Gateway, and DNS on projector (“Network > LAN”).
3. Open **Network and Sharing Center** page on your PC, and assign the identical network parameters to your PC as set on projector. Click “OK” to save the parameters.

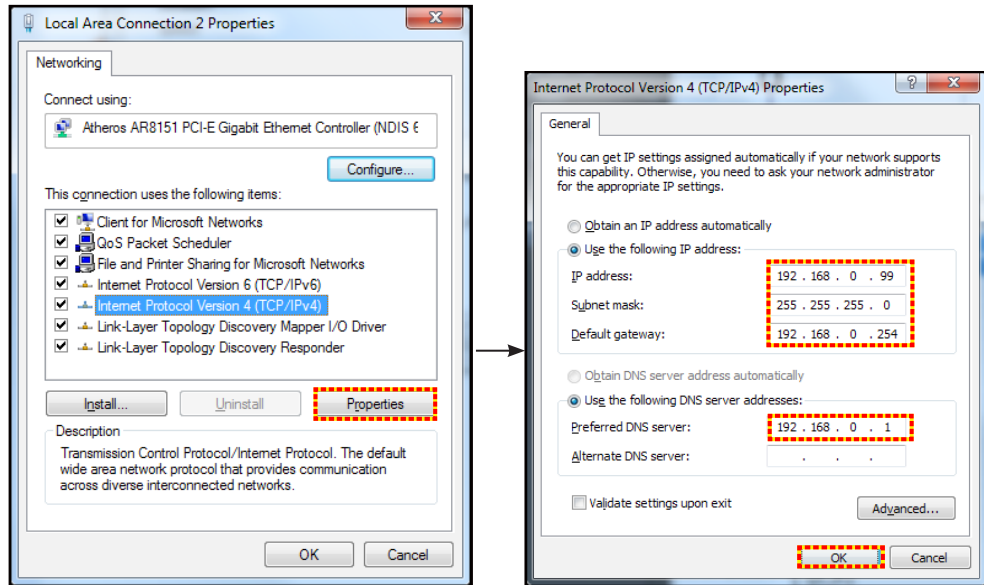

4. Open the web browser on your PC and type in to the URL field the IP address, assigned in step 3. Then press “Enter” key.

## Reset

Reset all values for LAN parameters.

## Network control menu

### HTTP

Use this function to select the network function (port:80).

- **On:** Enables projector network control using the internal interface.
- **Off:** Disables projector network control using the internal interface. Telnet control is still available.

# USING THE PROJECTOR

## Setup network control settings menu

### LAN\_RJ45 function

For simplicity and ease of operation, the projector provides diverse networking and remote management features. The LAN / RJ45 function of the projector through a network, such as remotely manage: Power On / Off, brightness, and contrast settings. Also, you can view the projector status information, such as: Video- Source, Sound-Mute, etc.

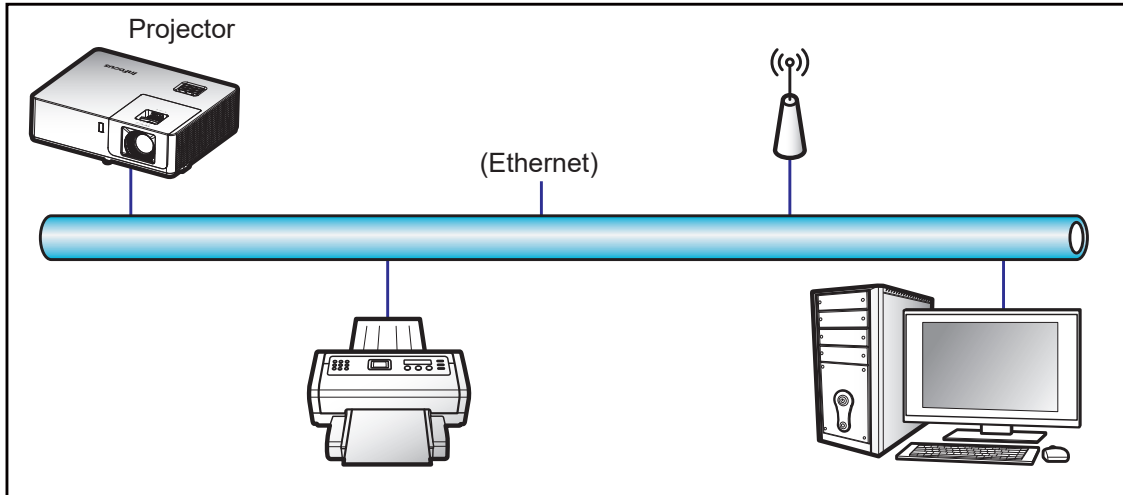

### Wired LAN terminal functionalities

The projector can be controlled via the LAN/RJ45 port. An interface can be accessed using your browser or telnet commands. Power on/off, sources, image settings are some of the available functions.

### LAN RJ45

1. Connect an RJ45 cable to RJ45 ports on the projector and the PC (laptop).

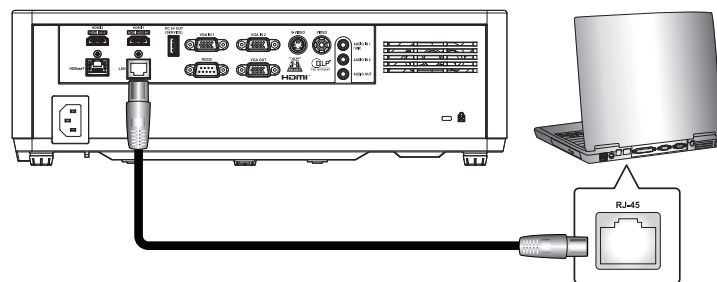

2. On the PC (Laptop), select **Start > Control Panel > Network Connections**.

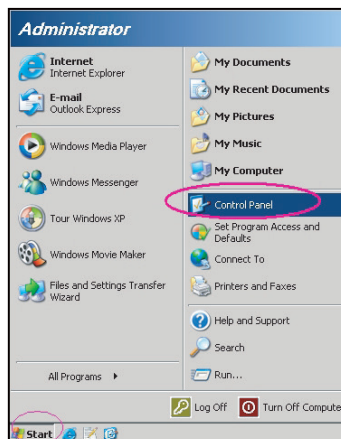

# USING THE PROJECTOR

3. Right-click on the **Local Area Connection**, and select **Property**.

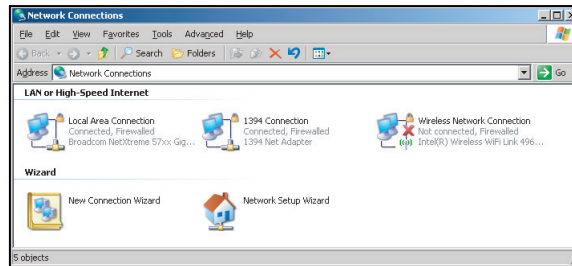

4. In the **Properties** window, select the **General** tab, and select **Internet Protocol (TCP / IP)**.

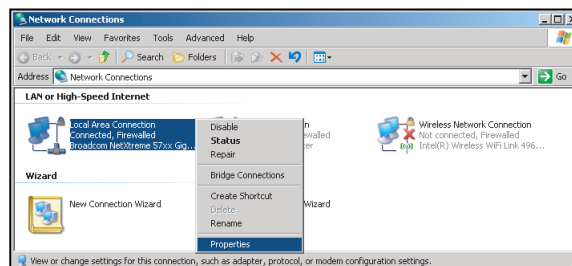

5. Click "Properties".

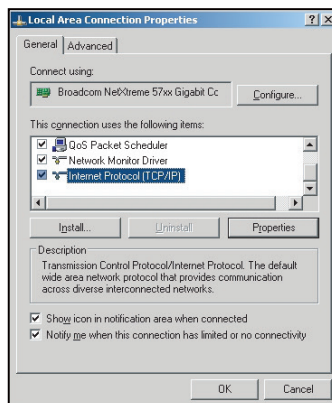

6. Type in the IP address and Subnet mask, then press "OK".

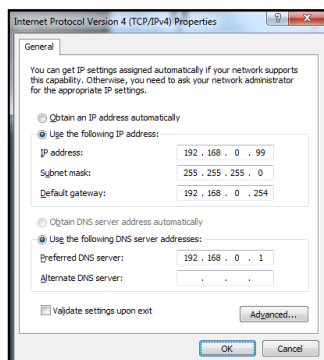

7. Press the "Menu" button on the projector.
8. Open on projector **Network > LAN**.
9. Enter the following connection parameters:
  - DHCP: Off
  - IP Address: 192.168.0.100
  - Subnet Mask: 255.255.255.0

# USING THE PROJECTOR

- Gateway: 192.168.0.254
  - DNS: 192.168.0.51
10. Press "Enter" to confirm settings.
  11. Open a web browser, for example Microsoft Internet Explorer with Adobe Flash Player 9.0 or higher installed.
  12. In the Address bar, input the projector's IP address: 192.168.0.100.



13. Press "Enter".
14. The Login page will be displayed. The default password is **admin**.

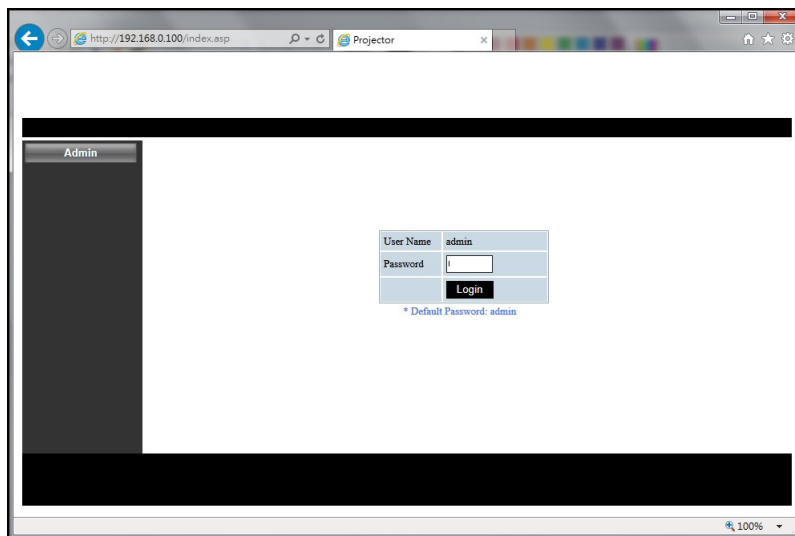

15. The System Status page will be displayed after log in. All network features are accessible from the buttons on the left. Reset to Default resets all projector settings. Reboot system reboots the network interface, not the projector.

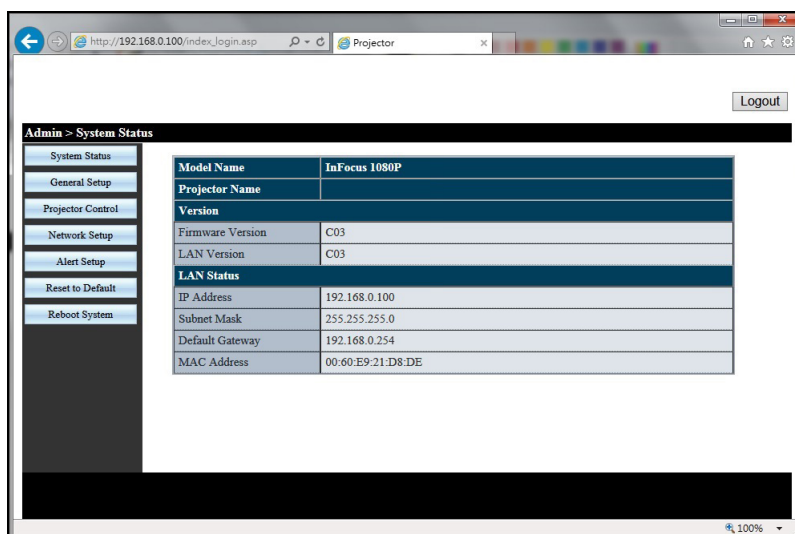

# USING THE PROJECTOR

16. The General Setup page allows changing the Projector Name and the admin password.

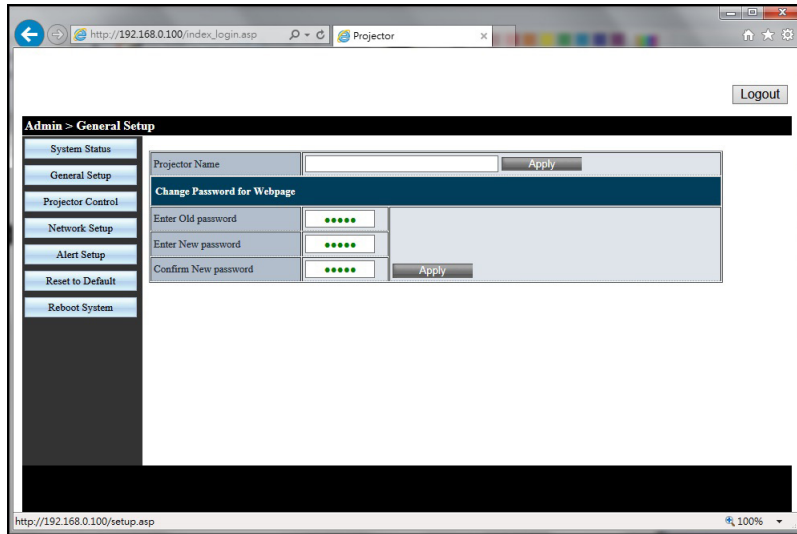

17. On the Projector Control page, you can perform many common network control functions such as changing the source and adjusting volume.

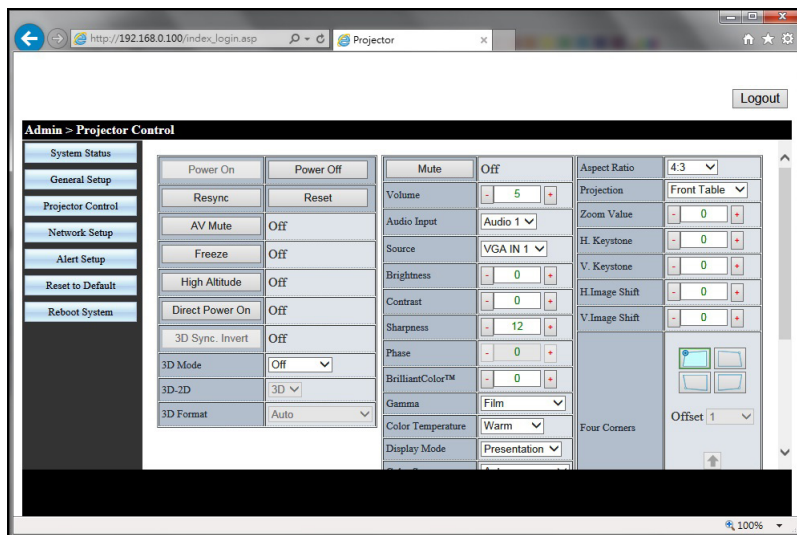

18. Network settings can be configured on the Network Setup page. If the IP address is changed the new IP address will have to be put in the url window of the browser to access Projector Control.

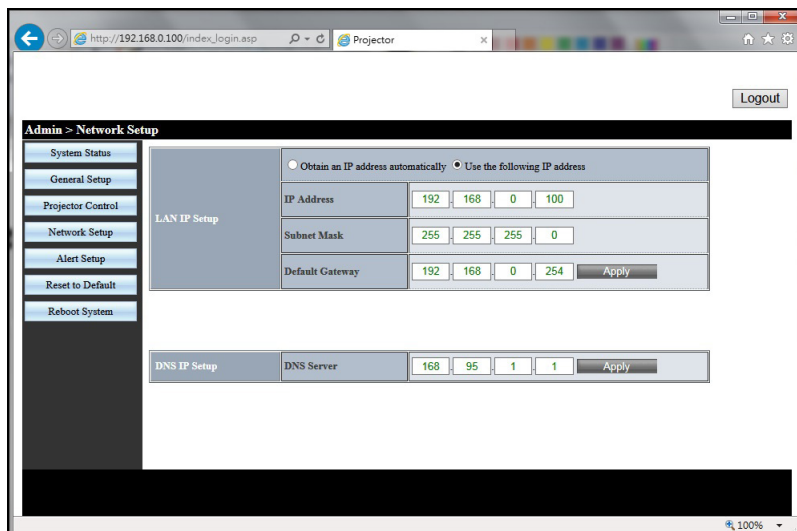

# USING THE PROJECTOR

- Alert setup will send an email if there is a fault with the projector. Click the check boxes to enable notification and select which faults you want to have reported.

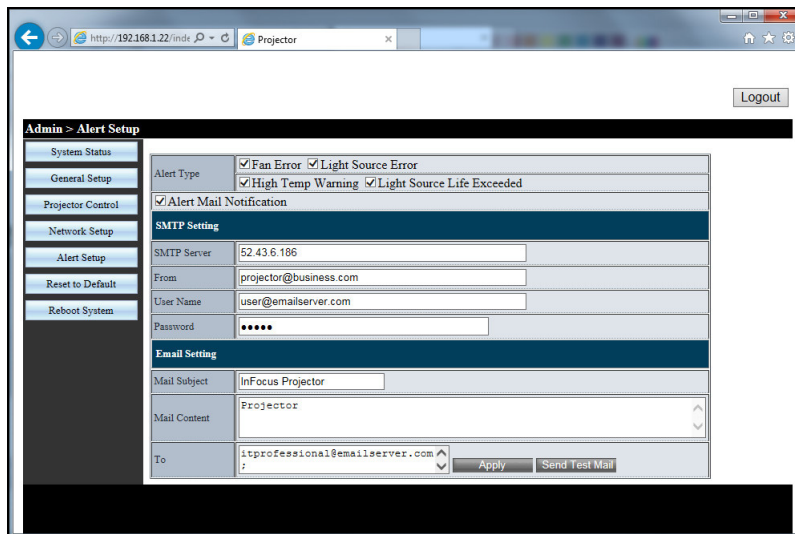

## Info menu

### Info menu

View the projector information as listed below:

- Serial Number
- Source
- Resolution
- Refresh Rate
- Display Mode
- Power Mode (Standby)
- Light Source Hours
- Network Status
- IP Address
- Brightness Mode
- Firmware Version

# ADDITIONAL INFORMATION

## Compatible resolutions

### Digital compatibility

Digital (HDMI 1.4)				
Digital native resolution: 1920 x 1080 @ 60Hz (IN1048SL) and 1920 x 1200 @ 60Hz (IN1049SL)				
Established Timing	Standard Timing	Descriptor timing -B0 (Detail timing)	Supported Video Mode	Descriptor timing -B1 (Detail timing)
720 x 400 @ 70Hz	1280 x 720 @ 60Hz	1080p:	640 x 480p @ 60Hz 4:3	1920 x 1080p @ 60Hz
640 x 480 @ 60Hz	1280 x 800 @ 60Hz	1920x1080@60Hz	720 x 480i @ 60Hz 16:9	1366 x 768 @ 60Hz
640 x 480 @ 67Hz	1280 x 1024 @ 60Hz	WUXGA:	720 x 480p @ 60Hz 4:3	1920 x 1080 @ 120Hz
640 x 480 @ 72Hz	640 x 480 @ 120Hz	1920x1200@60Hz-RB	720 x 480p @ 60Hz 16:9	1920 x 1200 @ 60Hz-RB (IN1048SL)
640 x 480 @ 75Hz	800 x 600 @ 120Hz		720 x 576i @ 50Hz 16:9	
800 x 600 @ 56Hz	1024 x 768 @ 120Hz		720 x 576p @ 50Hz 4:3	
800 x 600 @ 60Hz	1280 x 800 @ 120Hz		720 x 576p @ 50Hz 16:9	
800 x 600 @ 72Hz			1280 x 720p @ 60Hz 16:9	
800 x 600 @ 75Hz			1280 x 720p @ 50Hz 16:9	
832 x 624 @ 75Hz			1920 x 1080i @ 60Hz 16:9	
1024 x 768 @ 60Hz			1920 x 1080i @ 50Hz 16:9	
1024 x 768 @ 70Hz			1920 x 1080p @ 60Hz 16:9	
1024 x 768 @ 75Hz			1920 x 1080p @ 50Hz 16:9	
1280 x 1024 @ 75Hz			1920 x 1080p @ 24Hz 16:9	
1152 x 870 @ 75Hz			3840 x 2160 @ 24Hz	
			3840 x 2160 @ 25Hz	
			3840 x 2160 @ 30Hz	
			4096 x 2160 @ 24Hz	

Digital (HDMI 2.0)				
Digital native resolution: 1920 x 1080 @ 60Hz (IN1048SL) and 1920 x 1200 @ 60Hz (IN1049SL)				
Established Timing	Standard Timing	Descriptor timing -B0 (Detail timing)	Supported Video Mode	Descriptor timing -B1 (Detail timing)
720 x 400 @ 70Hz	1280 x 720 @ 60Hz	1080p:	640 x 480p @ 60Hz 4:3	1366 x 768 @ 60Hz
640 x 480 @ 60Hz	1280 x 800 @ 60Hz	1920 x 1080 @ 60Hz	720 x 480i @ 60Hz 16:9	1920 x 1080 @ 120Hz
640 x 480 @ 67Hz	1280 x 1024 @ 60Hz	WUXGA:	720 x 480p @ 60Hz 4:3	
640 x 480 @ 72Hz	640 x 480 @ 120Hz	1920 x 1200 @ 60Hz-RB	720 x 480p @ 60Hz 16:9	
640 x 480 @ 75Hz	800 x 600 @ 120Hz		720 x 576i @ 50Hz 16:9	
800 x 600 @ 56Hz	1024 x 768 @ 120Hz		720 x 576p @ 50Hz 4:3	
800 x 600 @ 60Hz	1280 x 800 @ 120Hz		720 x 576p @ 50Hz 16:9	
800 x 600 @ 72Hz			1280 x 720p @ 60Hz 16:9	
800 x 600 @ 75Hz			1280 x 720p @ 50Hz 16:9	
832 x 624 @ 75Hz			1920 x 1080i @ 60Hz 16:9	
1024 x 768 @ 60Hz			1920 x 1080i @ 50Hz 16:9	
1024 x 768 @ 70Hz			1920 x 1080p @ 60Hz 16:9	
1024 x 768 @ 75Hz			1920 x 1080p @ 50Hz 16:9	
1280 x 1024 @ 75Hz			1920 x 1080p @ 24Hz 16:9	

# ADDITIONAL INFORMATION

Digital (HDMI 2.0)				
Digital native resolution: 1920 x 1080 @ 60Hz (IN1048SL) and 1920 x 1200 @ 60Hz (IN1049SL)				
Established Timing	Standard Timing	Descriptor timing -B0 (Detail timing)	Supported Video Mode	Descriptor timing -B1 (Detail timing)
1152 x 870 @ 75Hz			3840 x 2160 @ 24Hz	
			3840 x 2160 @ 25Hz	
			3840 x 2160 @ 30Hz	
			4096 x 2160 @ 24Hz	
			3840 x 2160 @ 50Hz	
			3840 x 2160 @ 60Hz	
			4096 x 2160 @ 50Hz	
			4096 x 2160 @ 60Hz	
			4096 x 2160 @ 25Hz	
			4096 x 2160 @ 30Hz	

**Note:** Functions vary depending on model definition.

## Analog compatibility

Analog				
Analog native resolution: 1920 x 1080 @ 60Hz (IN1048SL) and 1920 x 1200 @ 60Hz (IN1049SL)				
B0/Established Timing	B0/Standard Timing	B0/Detail Timing	B1/Video Mode	B1/Detail Timing
720 x 400 @ 70Hz	1280 x 720 @ 60Hz	1080p:		1366 x 768 @ 60Hz
640 x 480 @ 60Hz	1280 x 800 @ 60Hz	1920 x 1080 @ 60Hz		1280 x 800 @ 120Hz (RB)
640 x 480 @ 67Hz	1280 x 1024 @ 60Hz	WUXGA:		1900 x 1200 @ 60Hz (RB) (IN1048SL)
640 x 480 @ 72Hz	640 x 480 @ 120Hz	1920 x 1200 @ 60Hz-RB		
640 x 480 @ 75Hz	800 x 600 @ 120Hz			
800 x 600 @ 56Hz	1024 x 768 @ 120Hz			
800 x 600 @ 60Hz				
800 x 600 @ 72Hz				
800 x 600 @ 75Hz				
832 x 624 @ 75Hz				
1024 x 768 @ 60Hz				
1024 x 768 @ 70Hz				
1024 x 768 @ 75Hz				
1280 x 1024 @ 75Hz				
1152 x 870 @ 75Hz				

**Note:** Functions vary depending on model definition.

# ADDITIONAL INFORMATION

## True 3D video compatibility

Input resolutions	HDMI 1.4a 3D Input	Input timing		
		1280 x 720P @ 50Hz	Top-and-Bottom	
		1280 x 720P @ 60Hz	Top-and-Bottom	
		1280 x 720P @ 50Hz	Frame packing	
		1280 x 720P @ 60Hz	Frame packing	
		1920 x 1080i @ 50Hz	Side-by-Side(Half)	
		1920 x 1080i @ 60Hz	Side-by-Side(Half)	
		1920 x 1080P @ 24Hz	Top-and-Bottom	
		1920 x 1080P @ 24Hz	Frame packing	
	HDMI 1.3	1920 x 1080i @ 50Hz	Side-by-Side(Half)	SBS mode is on
		1920 x 1080i @ 60Hz		
		1280 x 720P @ 50Hz		
		1280 x 720P @ 60Hz		
		1920 x 1080i @ 50Hz	Top-and-Bottom	TAB mode is on
		1920 x 1080i @ 60Hz		
		1280 x 720P @ 50Hz		
		1280 x 720P @ 60Hz		
		480i	HQFS	3D format is Frame sequential

### Note:

- If 3D input is 1080p@24Hz, the DMD should replay with integral multiple with 3D mode.
- 1080i@25Hz and 720p@50Hz will run in 100Hz; 1080p@24Hz will run in 144Hz; other 3D timing will run in 120Hz.
- Functions vary depending on model definition.

# ADDITIONAL INFORMATION

## Image size and projection distance

### 1080p series

Projection image size is from 20" to 300" (0.5m to 7.6m).

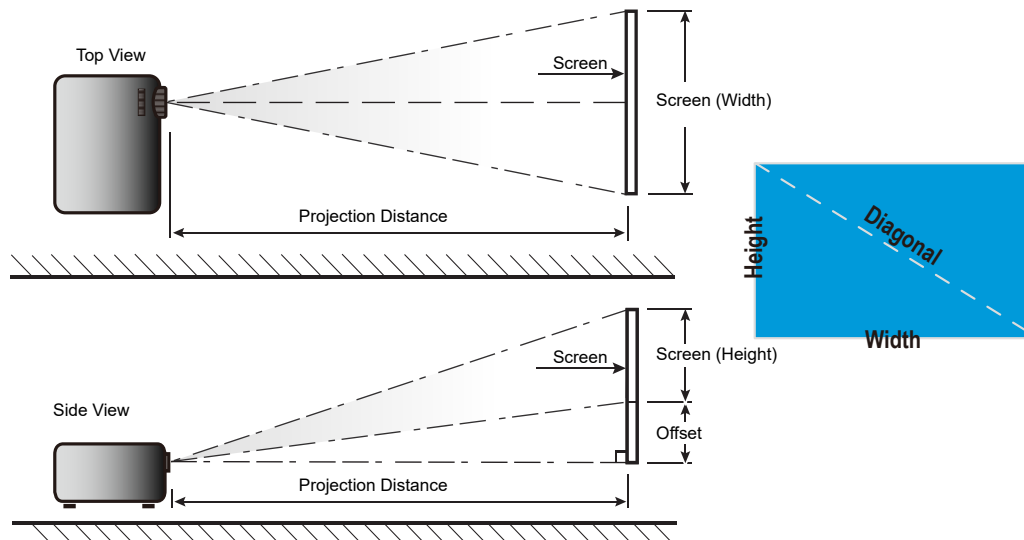

16:9 diagonal screen inches	Screen size				Projection distance				Offset	
	(inches)		(meters)		(feet)		(meters)		(cm)	(inches)
	Height	Width	Height	Width	Wide	Tele	Wide	Tele		
20	9.81	17.43	0.25	0.44	2.03	3.25	0.62	0.99	0.75~4.48	0.29~1.76
40	19.61	34.86	0.50	0.89	4.07	6.51	1.24	1.98	1.49~8.97	0.59~3.53
60	29.42	52.29	0.75	1.33	6.10	9.76	1.86	2.98	2.24~13.45	0.88~5.29
70	34.32	61.01	0.87	1.55	7.12	11.39	2.17	3.47	2.62~15.69	1.03~6.18
80	39.22	69.73	1.00	1.77	8.13	13.02	2.48	3.97	2.99~17.93	1.18~7.06
90	44.12	78.44	1.12	1.99	9.15	14.64	2.79	4.46	3.36~20.17	1.32~7.94
100	49.03	87.16	1.25	2.21	10.17	16.27	3.10	4.96	3.74~22.41	1.47~8.82
120	58.83	104.59	1.49	2.66	12.20	19.52	3.72	5.95	4.48~26.90	1.76~10.59
150	73.54	130.74	1.87	3.32	15.25	24.40	4.65	7.44	5.60~33.62	2.21~13.24
200	98.05	174.32	2.49	4.43	20.34	32.54	6.20	9.92	7.47~44.83	2.94~17.65
250	122.57	217.89	3.11	5.53	25.42	40.67	7.75	12.40	9.34~56.04	3.68~22.06
300	147.08	261.47	3.74	6.64	30.51	48.81	9.30	14.88	11.21~67.24	4.41~26.47

Zoom Ratio: 1.6x

Offset			
cm (min)	inches (min)	cm (max)	inches (max)
0.75	0.29	4.48	1.76
1.49	0.59	8.97	3.53
2.24	0.88	13.45	5.29
2.62	1.03	15.69	6.18
2.99	1.18	17.93	7.06
3.36	1.32	20.17	7.94
3.74	1.47	22.41	8.82
4.48	1.76	26.90	10.59
5.60	2.21	33.62	13.24
7.47	2.94	44.83	17.65
9.34	3.68	56.04	22.06
11.21	4.41	67.24	26.47

# ADDITIONAL INFORMATION

## WUXGA series

Projection image size is from 21" to 302" (0.5m to 7.7m).

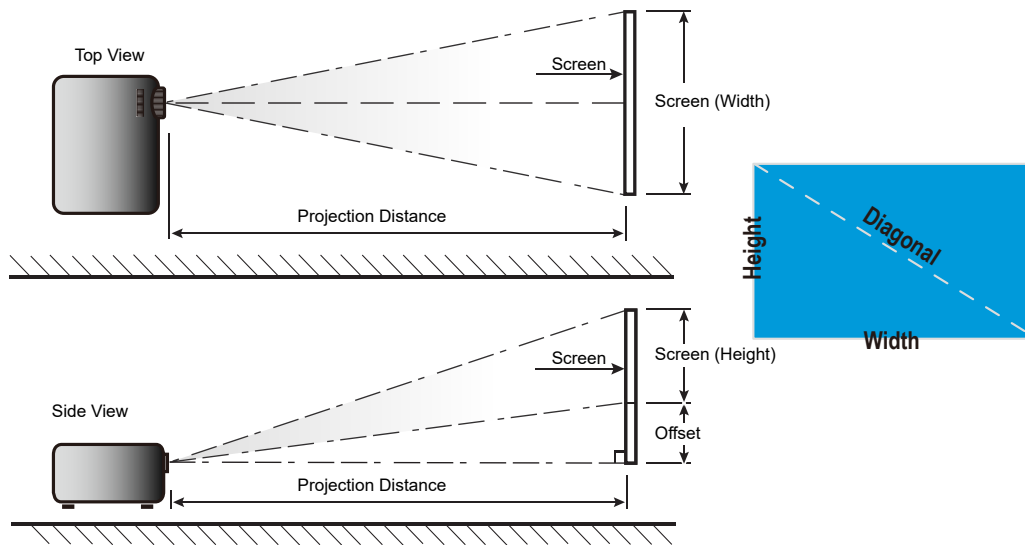

16:9 diagonal screen inches	Screen size				Projection distance				Offset	
	(inches)		(meters)		(feet)		(meters)		(cm)	(inches)
	Height	Width	Height	Width	Wide	Tele	Wide	Tele		
21	11.13	17.81	0.28	0.45	2.08	3.32	0.63	1.01	-1.41~1.98	-0.56~0.78
40	21.20	33.92	0.54	0.86	3.96	6.33	1.21	1.93	-2.69~3.77	-1.06~1.48
60	31.80	50.88	0.81	1.29	5.94	9.50	1.81	2.89	-4.04~5.65	-1.59~2.23
70	37.10	59.36	0.94	1.51	6.93	11.08	2.11	3.38	-4.71~6.60	-1.85~2.60
80	42.40	67.84	1.08	1.72	7.91	12.66	2.41	3.86	-5.38~7.54	-2.12~2.97
90	47.70	76.32	1.21	1.94	8.90	14.25	2.71	4.34	-6.06~8.48	-2.38~3.34
100	53.00	84.80	1.35	2.15	9.89	15.83	3.02	4.82	-6.73~9.42	-2.65~3.71
120	63.60	101.76	1.62	2.58	11.87	19.00	3.62	5.79	-8.08~11.31	-3.18~4.45
150	79.50	127.20	2.02	3.23	14.84	23.74	4.52	7.24	-10.10~14.14	-3.97~5.56
200	106.00	169.60	2.69	4.31	19.79	31.66	6.03	9.65	-13.46~18.85	-5.30~7.42
250	132.50	212.00	3.37	5.38	24.73	39.57	7.54	12.06	-16.83~23.56	-6.62~9.27
300	159.00	254.40	4.04	6.46	29.68	47.49	9.05	14.47	-20.19~28.27	-7.95~11.13
302	160.06	256.10	4.07	6.50	29.88	47.80	9.11	14.57	-20.33~28.46	-8.00~11.20

Zoom Ratio: 1.6x

Offset			
cm (min)	inches (min)	cm (max)	inches (max)
-1.41	-0.56	1.98	0.78
-2.69	-1.06	3.77	1.48
-4.04	-1.59	5.65	2.23
-4.71	-1.85	6.60	2.60
-5.38	-2.12	7.54	2.97
-6.06	-2.38	8.48	3.34
-6.73	-2.65	9.42	3.71
-8.08	-3.18	11.31	4.45
-10.10	-3.97	14.14	5.56
-13.46	-5.30	18.85	7.42
-16.83	-6.62	23.56	9.27
-20.19	-7.95	28.27	11.13
-20.33	-8.00	28.46	11.20

# ADDITIONAL INFORMATION

## Projector dimensions and ceiling mount installation

To prevent damage to your projector, please use only approved InFocus ceiling mounts:  
<https://www.infocus.com/accessories/mounts>

If you wish to use a third party ceiling mount kit, please ensure the screws used to attach a mount to the projector meet the following specifications:

- Screw type: M6\*10
- Minimum screw length: 10mm

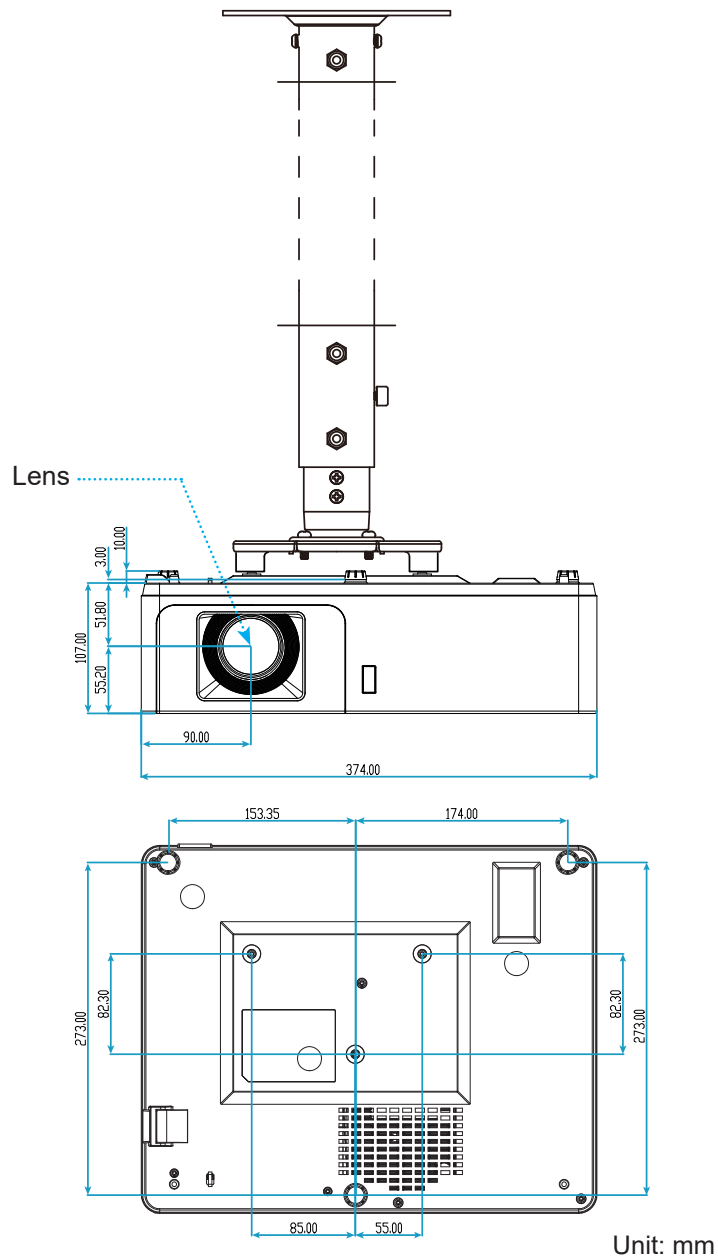

**Note:** Please note that damage resulting from incorrect installation will void the warranty.



Warning:

- If you buy a ceiling mount from another company, please be sure to use the correct screw size. Screw size will vary depending on the thickness of the mounting plate.
- Be sure to keep at least 10 cm gap between the ceiling and the bottom of the projector.
- Avoid installing the projector near a heat source.

# ADDITIONAL INFORMATION

## RS232 Commands and Protocol Function List

### RS232 Pin Assignments

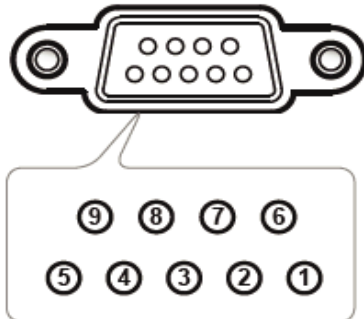

Pin no.	Descriptor timing -B0 (Detail timing)
1	N/A
2	RXD
3	TXD
4	N/A
5	GND
6	N/A
7	N/A
8	N/A
9	N/A

### RS232 Protocol Function List

Baud Rate: 19200

Parity Bit: None

Data Bit: 8

Stop Bit: 1

Laser on delay = 20s

Power Down delay = 5s (IN1048SL)

Power Down delay = 125s (IN1049SL)

Source change delay = 8s

Intercommand delay minimum = 500ms

Intercharacter delay minimum = 2ms

Power		return code (ok)
Status ?	(PWR?)	(0-1,n) n=0,1
ON	(PWR1)	
OFF	(PWR0)	
ON & return	(PWR1!)	(0-1,1)
OFF & return	(PWR0!)	(0-1,0)
Blank Key (AV Mute)		return code (ok)
Status ?	(BLK?)	(0-1,n) n=0,1
ON	(BLK1)	
OFF	(BLK0)	

# ADDITIONAL INFORMATION

Blank Key (AV Mute)		return code (ok)
ON & return	(BLK1!)	(0-1,1)
OFF & return	(BLK0!)	(0-1,0)
Source		return code (ok)
Status ?	(SRC?)	(0-22,n) n=0-22
Computer1 (VGA IN 1)	(SRC0)	
Computer2 (VGA IN 2)	(SRC1)	
VIDEO	(SRC11)	
S-VIDEO	(SRC12)	
HDMI1	(SRC4)	
HDMI2	(SRC5)	
HDBaseT	(SRC17)	
Computer1 (VGA IN 1) & return	(SRC0!)	(0-22,0)
Computer2 (VGA IN 2) & return	(SRC1!)	(0-22,1)
VIDEO & return	(SRC11!)	(0-22,11)
S-VIDEO & return	(SRC12!)	(0-22,12)
HDMI1 & return	(SRC4!)	(0-22,4)
HDMI2 & return	(SRC5!)	(0-22,5)
HDBaseT & return	(SRC17!)	(0-22,17)
Aspect		return code (ok)
Status ?	(ARZ?)	(0-6,n) n=0,1,2,3,4,6
Auto	(ARZ0)	
Native	(ARZ1)	
4 X 3	(ARZ2)	
16 X 9	(ARZ3)	
Letterbox	(ARZ4)	
16 X 10	(ARZ6)	
Auto & return	(ARZ0!)	(0-6,0)
Native & return	(ARZ1!)	(0-6,1)
4 X 3 & return	(ARZ2!)	(0-6,2)
16 X 9 & return	(ARZ3!)	(0-6,3)
Letterbox & return	(ARZ4!)	(0-6,4)
16 X 10 & return	(ARZ6!)	(0-6,6)
Volume		return code (ok)
Status ?	(VOL?)	(0-10,nn) n=0~10
volume +	(VOL+)	
volume -	(VOL-)	
Set volume	(VOLnn) n=0 ~ 10	
volume + & return	(VOL+!)	(0-10,nn) n=0~10
volume - & return	(VOL-!)	(0-10,nn) n=0~10
Set volume & return	(VOLnn!) n=0 ~ 10	(0-10,nn) n=0~10
Mute		return code (ok)
Status ?	(MTE?)	(0-1,n) n=0,1
ON	(MTE1)	
OFF	(MTE0)	
ON & return	(MTE1!)	(0-1,1)
OFF & return	(MTE0!)	(0-1,0)
Firmwave Version		return code (ok)
Status ?	(FVS?)	(nnnn) n=x.x.xx

# ADDITIONAL INFORMATION

Total Hours (Light Source Hours)		return code (ok)
Status ?	(LMT?)	(0-65535,n) n=lamp hours
Ceiling Set		return code (ok)
Status ?	(CEL?)	(0-3,n) n=0,1,2,3
Front table	(CEL0)	
Front ceiling	(CEL1)	
Rear table	(CEL2)	
Rear ceiling	(CEL3)	
Front table & return	(CEL0!)	(0-3,0)
Front ceiling & return	(CEL1!)	(0-3,1)
Rear table & return	(CEL2!)	(0-3,2)
Rear ceiling & return	(CEL3!)	(0-3,3)
Brightness		return code (ok)
Status ?	(BRT?)	(-50-50,n) n=-50~50
Brightness +	(BRT+)	
Brightness -	(BRT-)	
Set Brightness	(BRTnn) n=-50~50	
Brightness + & return	(BRT+!)	(-50-50,n) n=-50~50
Brightness - & return	(BRT-!)	(-50-50,n) n=-50~50
Set Brightness & return	(BRTnn!) n=-50~50	(-50-50,n) n=-50~50
Contrast		return code (ok)
Status ?	(CON?)	(-50-50,n) n=-50~50
Contrast +	(CON+)	
Contrast -	(CON-)	
Set Contrast	(CONnn) n=-50~50	
Contrast + & return	(CON+!)	(-50-50,n) n=-50~50
Contrast - & return	(CON-!)	(-50-50,n) n=-50~50
Set Contrast & return	(CONnn!) n=-50~50	(-50-50,n) n=-50~50
Presets		return code (ok)
Status ?	(PST?)	(0-13,n) n=0-13
User	(PST1)	
Presentation	(PST5)	
Cinema	(PST7)	
Bright	(PST10)	
sRGB	(PST11)	
User & return	(PST1!)	(0-13,1)
Presentation & return	(PST5!)	(0-13,5)
Video (Cinema) & return	(PST7!)	(0-13,7)
Bright & return	(PST10!)	(0-13,10)
sRGB & return	(PST11!)	(0-13,11)
Freeze		return code (ok)
Status ?	(FRZ?)	(0-1,n) n=0-1
Freeze ON	(FRZ1)	
Freeze OFF	(FRZ0)	
Freeze ON & return	(FRZ1!)	(0-1,1)
Freeze OFF & return	(FRZ0!)	(0-1,0)
Key Pad		return code (ok)
Menu	(NAV0)	
Up	(NAV1)	

# ADDITIONAL INFORMATION

Key Pad		return code (ok)
Down	(NAV2)	
Select	(NAV3)	
Left	(NAV4)	
Right	(NAV5)	
Menu & return	(NAV0!)	(0-5,0)
Up & return	(NAV1!)	(0-5,1)
Down & return	(NAV2!)	(0-5,2)
Select & return	(NAV3!)	(0-5,3)
Left & return	(NAV4!)	(0-5,4)
Right & return	(NAV5!)	(0-5,5)

# ADDITIONAL INFORMATION

## Troubleshooting

If you experience a problem with your projector, please refer to the following information. If a problem persists, please contact your local reseller or service center.

### Image problems

- ❓ *No image appears on screen*
  - Ensure all the cables and power connections are correctly and securely connected as described in the "Installation" section.
  - Ensure the pins of connectors are not crooked or broken.
  - Ensure the "Mute" or "AV Mute" features are not turned on.
  
- ❓ *Image is out of focus*
  - Turn the focus ring clockwise or counterclockwise until the image is sharp and legible. (Please see page 17).
  - Make sure the projection screen is between the required distances from the projector. (Please refer to pages 51-52).
  
- ❓ *The image is stretched when displaying 16:9 DVD title*
  - When playing anamorphic sources or 16:9 sources the projector will display the best image in 16:9 format.
  - When playing a Letterbox (LBX) formatted source change the Aspect Ratio to LBX.
  - If you play 4:3 format DVD title, please change the format as 4:3 in projector OSD.
  - Please setup the display format as 16:9 (wide) aspect ratio type on your DVD player.
  
- ❓ *Image is too small or too large*
  - Turn the zoom ring clockwise or counterclockwise to increase or decrease the projected image size. (Please see page 17).
  - Move the projector closer to or further from the screen.
  - Press "Menu" on the projector panel, go to "Display → Aspect Ratio". Try the different settings.
  
- ❓ *Image has slanted sides:*
  - If possible, reposition the projector so that it is centered on the screen and below the bottom of the screen.
  - Adjust the vertical keystone until the sides are parallel.
  
- ❓ *Image is reversed*
  - Select "Setup → Projection" from the OSD and adjust the projection orientation.

# ADDITIONAL INFORMATION

## Other problems



*The projector stops responding to all controls*

- If possible, turn off the projector, then unplug the power cord and wait at least 20 seconds before reconnecting power.

## Remote control problems



*If the remote control does not work*

- Check the operating angle of the remote control is within  $\pm 20^\circ$  to the IR receiver on the projector.
- Make sure there are not any obstructions between the remote control and the projector. Move to within 5 m (16.4 ft) of the projector.
- Make sure there are no fluorescent light sources shining on the IR receivers.
- Make sure batteries are inserted correctly.
- Replace batteries if they are exhausted.

# ADDITIONAL INFORMATION

## Warning indicators

When the warning indicators (see below) light up or flash, the projector will automatically shutdown:

- “Lamp” LED indicator is lit red and if “Power” indicator flashes red.
- “Temp” LED indicator is lit red and if “Power” indicator flashes red. This indicates the projector has overheated. Under normal conditions, the project can be switched back on.
- “Temp” LED indicator flashes red and if “Power” indicator flashes red.

Unplug the power cord from the projector, wait for 30 seconds and try again. If the warning indicators light up or flash please contact your nearest service center for assistance.

## LED lightning messages

Message	Power LED		Temp LED	Laser LED
	(Red)	(Blue)	(Red)	(Red)
Standby state (Input power cord)	Steady light			
Power on (Warming)		Flashing (0.5 sec off / 0.5 sec on)		
Power on and Lamp lighting		Steady light		
Power off (Cooling)		Flashing (0.5 sec off / 0.5 sec on). Back to red steady light when cooling fan turns off.		
Error (Laser failure)	Flashing			Steady light
Error (Fan failure)	Flashing		Flashing	
Error (Over temp.)	Flashing		Steady light	

- Power off:

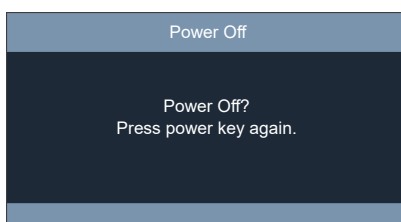

- Temperature warning:

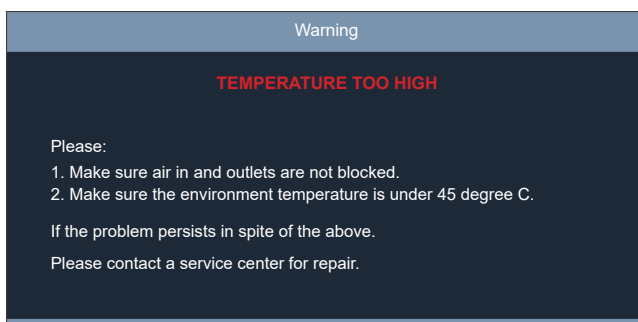

# ADDITIONAL INFORMATION

## Specifications

Optical	Description
Maximum resolution	1920x1200@60Hz(RB)
Native resolution	<ul style="list-style-type: none"> <li>1080p</li> <li>WUXGA</li> </ul>
Lens	Manual zoom, focus and vertical shift
Image size (diagonal)	<ul style="list-style-type: none"> <li>1080p: 20" ~ 300" (51cm ~ 762cm)</li> <li>WUXGA: 21" ~ 302" (53cm ~ 767cm)</li> </ul>
Projection distance	<ul style="list-style-type: none"> <li>1080p: 1.0m ~ 9.3m (20" ~300')</li> <li>WUXGA: 1.0m ~ 9.1m (21" ~302')</li> </ul>

Electrical	Description
Inputs	<ul style="list-style-type: none"> <li>HDMI 1.4b</li> <li>HDMI 2.0</li> <li>VGA In</li> <li>Composite (RCA connector (Y))</li> <li>VGA In (2)</li> <li>Audio In 3.5mm</li> <li>Audio In 3.5mm, with Microphone</li> <li>USB Type-A for power USB 5V/1.5A</li> <li>S-Video</li> </ul>
Outputs	<ul style="list-style-type: none"> <li>VGA Out</li> <li>Audio Out 3.5mm</li> </ul>
Control	<ul style="list-style-type: none"> <li>RS232</li> <li>RJ-45</li> <li>RJ-45 for HDBaseT</li> </ul>
Color reproduction	1073.4 Million color
Scan rate	<ul style="list-style-type: none"> <li>Horizontal scan rate: 15.375~91.146 KHz</li> <li>Vertical scan rate: 24 ~ 120 Hz</li> </ul>
Built-in speaker	10W
Power requirement	100 - 240V ±10%, AC 50/60Hz
Input current	3.7A

Mechanical	Description
Installation orientation	Front, Rear, Ceiling-top, Rear-top
Dimensions	374mm (W) x 302mm (D) x 117mm( H) (with feet)
Weight	5.5 ±0.5kg
Environmental conditions	Operating in 5 ~ 40°C, 10% to 85% humidity (non-condensing)

**Note:** All specifications are subject to change without notice.