



Hewlett Packard
Enterprise

HPE ProLiant DL145 Gen11 Server User Guide

Part Number: 30-C981C518-002

Published: March 2025

Edition: 2

HPE ProLiant DL145 Gen11 Server User Guide

Abstract

This document is for the person who installs, administers, and troubleshoots servers and storage systems. Hewlett Packard Enterprise assumes you are qualified in the servicing of computer equipment and trained in recognizing hazards in products with hazardous energy levels, and are familiar with the weight and stability precautions for rack installations.

Part Number: 30-C981C518-002

Published: March 2025

Edition: 2

© Copyright 2024–2025 Hewlett Packard Enterprise Development LP

Notices

The information contained herein is subject to change without notice. The only warranties for Hewlett Packard Enterprise products and services are set forth in the express warranty statements accompanying such products and services. Nothing herein should be construed as constituting an additional warranty. Hewlett Packard Enterprise shall not be liable for technical or editorial errors or omissions contained herein.

Confidential computer software. Valid license from Hewlett Packard Enterprise required for possession, use, or copying. Consistent with FAR 12.211 and 12.212, Commercial Computer Software, Computer Software Documentation, and Technical Data for Commercial Items are licensed to the U.S. Government under vendor's standard commercial license.

Links to third-party websites take you outside the Hewlett Packard Enterprise website. Hewlett Packard Enterprise has no control over and is not responsible for information outside the Hewlett Packard Enterprise website.

Acknowledgments

AMD and AMD EPYC™ are trademarks of Advanced Micro Devices, Inc.

Linux® is the registered trademark of Linus Torvalds in the U.S. and other countries.

Microsoft®, Windows®, and Windows Server® are either registered trademarks or trademarks of Microsoft Corporation in the United States and/or other countries.

VMware® is a registered trademark or trademark of VMware, Inc. and its subsidiaries in the United States and other jurisdictions.

All third-party marks are property of their respective owners.

Table of contents

- Component identification
 - Front panel components
 - iLO Service Port
 - Display device setup
 - Front panel LEDs and buttons
 - Server UID LED
 - Using the UID button to view the Server Health Summary
 - Front panel LED power fault codes
 - Component touchpoints
 - System board components
 - System maintenance switch descriptions
 - DIMM label identification
 - DIMM slot numbering
 - Processor and socket components
 - Riser board components
 - Riser slot numbering
 - HPE Basic Drive LED definitions
 - EDSFF SSD LED definitions
 - Drive bay numbering
 - SFF drive bay numbering
 - E3.S drive bay numbering
 - Drive backplane naming
 - GPU numbering
 - Power distribution board (PDB) components
 - Fan numbering
 - Fan and heatsink requirements
 - Trusted Platform Module 2.0
 - Trusted Platform Module 2.0 guidelines
 - BitLocker recovery key/password retention guidelines
 - HPE NS204i-u Boot Device components
 - HPE NS204i-u Boot Device LED definitions
- Setup
 - Initial system installation
 - HPE Installation Service
 - Setting up the server
 - Operational requirements
 - Space and airflow requirements
 - Temperature requirements
 - Extended ambient operating support

- Power requirements
- Electrical grounding requirements
- Rack warnings and cautions
- Server warnings and cautions
- Electrostatic discharge
- Operations
 - Remove the front bezel
 - Power down the server
 - Open the cable management arm
 - Extend the server out of the rack
 - Remove the server from a four-post rack
 - Remove the server from a two-post rack
 - Remove the access panel
 - Remove the air baffle
 - Remove the three-slot riser cage
 - Remove the drive base cage with the SFF/E3.S drive cage installed
 - Install the drive base cage with the SFF/E3.S drive cage installed
 - Install the three-slot riser cage
 - Install the air baffle
 - Install the access panel
 - Power up the server
- Hardware options installation
 - Server data backup
 - Hardware option installation guidelines
 - Hewlett Packard Enterprise product QuickSpecs
 - Rack mounting options
 - Four-post rack mounting options
 - Rack enablement option
 - Installing the rack mount brackets on the server
 - Rail identification markers
 - Rack mounting interfaces
 - Rack rail option
 - Installing the rack rail
 - Installing the server into a four-post rack
 - Installing the rack rail hook-and-loop strap
 - Preparing the cable management arm
 - Installing the cable management arm
 - Two-post rack mounting options
 - Rack enablement option kit
 - Two-post rack support kit
 - Installing the server into a two-post rack

- Wall mounting and desktop installation options
 - Determine the location for the wall mount or desktop installation hardware
 - Wall mounting and desktop installation hardware
 - Wall mount connecting brackets
 - Side covers
 - Installing the server in the wall mount
 - Configuring the side covers for wall mounting
 - Installing the connecting brackets
 - Installing the wall mount on the wall
 - Installing the server on the wall mount bracket
 - Installing the side covers for desktop installation
- Installing the front bezel option
- Front bezel filter replacement kit option
 - Front bezel filter maintenance guidelines
- Power supply options
 - Hot-plug power supply calculations
 - Power supply warnings and cautions
 - DC power supply warnings and cautions
 - DC power supply wire colors
 - Installing an AC power supply
 - Installing a DC power supply
 - Connecting a DC power cable to a DC power source
- Drive options
 - Drive installation guidelines
 - Installing a hot-plug SFF drive
 - Installing an E3.S drive
- Drive cage options
 - Converting from 2 SFF to 4 E3.S drive configuration
 - Upgrading from 4 E3.S to 6 E3.S drive configuration
 - Converting from 4 E3.S to 2 SFF drive configuration
- Fan options
 - Fan mode behavior
 - Installing a fan
- Memory option
 - HPE SmartMemory speed and population information
 - DIMM installation guidelines
 - Installing a DIMM
- Stacking riser options
 - Installing the stacking risers
- Storage controller options
 - Preparing the server for storage controller installation

- Installing a type-p storage controller on the three-slot riser cage
- Installing a type-o storage controller
- Energy pack option
 - HPE Smart Storage Battery
 - Installing an energy pack
- Expansion card options
 - GPU options
 - GPU installation guidelines
 - Installing an expansion card on the base riser
 - Installing an expansion card on the stacking riser
- HPE NS204i-u Boot Device option
 - Installing the HPE NS204i-u Boot Device on the front panel
- OCP NIC 3.0 adapter option
 - Installing an OCP NIC 3.0 adapter
- Chassis intrusion detection switch option
 - Installing the chassis intrusion detection switch
- Serial port option
 - Installing the RJ45-serial port cable option
- Cabling
 - Cabling guidelines
 - Cabling diagrams
 - Internal cabling management
 - Stacking riser cabling
 - Storage cabling
 - Storage controller cabling
 - 2 SFF SATA/NVMe drive controller cabling
 - 4 E3.S NVMe drive controller cabling
 - 4 + 2 E3.S NVMe drive controller cabling
 - Drive power cabling
 - Energy pack cabling
 - Storage controller backup power cabling
 - HPE NS204i-u Boot Device cabling
 - iLO service port cabling
 - RJ45-serial port cabling
 - Ambient temperature sensor cabling
 - System power cabling
 - Chassis intrusion detection switch cabling
- Configuration resources
 - Updating firmware or system ROM
 - Configuring the server
 - Configuring storage controllers

- Deploying an OS
- Configuring security
- Server management
- Managing Linux-based high performance compute clusters
- Troubleshooting
 - NMI functionality
 - Troubleshooting resources
- System battery replacement
 - System battery information
 - Removing and replacing the system battery
- Safety, warranty, and regulatory information
 - Regulatory information
 - Notices for Eurasian Economic Union
 - Turkey RoHS material content declaration
 - Ukraine RoHS material content declaration
 - Warranty information
- Specifications
 - Environmental specifications
 - Mechanical specifications
 - Power supply specifications
 - HPE 700 W Flex Slot Platinum Hot-plug Power Supply
 - HPE 700 W Flex Slot -48 VDC Hot-plug Low Halogen Power Supply
 - HPE 900 W-1000 W Flex Slot Titanium Hot-plug Power Supply
- Websites
- Support and other resources
 - Accessing Hewlett Packard Enterprise Support
 - HPE product registration
 - Accessing updates
 - Customer self repair
 - Remote support
 - Documentation feedback

Component identification

This chapter describes the external and internal server features and components.

Subtopics

[Front panel components](#)

[Front panel LEDs and buttons](#)

[Component touchpoints](#)

[System board components](#)

[Riser board components](#)

[Riser slot numbering](#)

[HPE Basic Drive LED definitions](#)

[EDSFF SSD LED definitions](#)

[Drive bay numbering](#)

[Drive backplane naming](#)

[GPU numbering](#)

[Power distribution board \(PDB\) components](#)

[Fan numbering](#)

[Trusted Platform Module 2.0](#)

[HPE NS204i-u Boot Device components](#)

[HPE NS204i-u Boot Device LED definitions](#)

Front panel components

2 SFF drive configuration

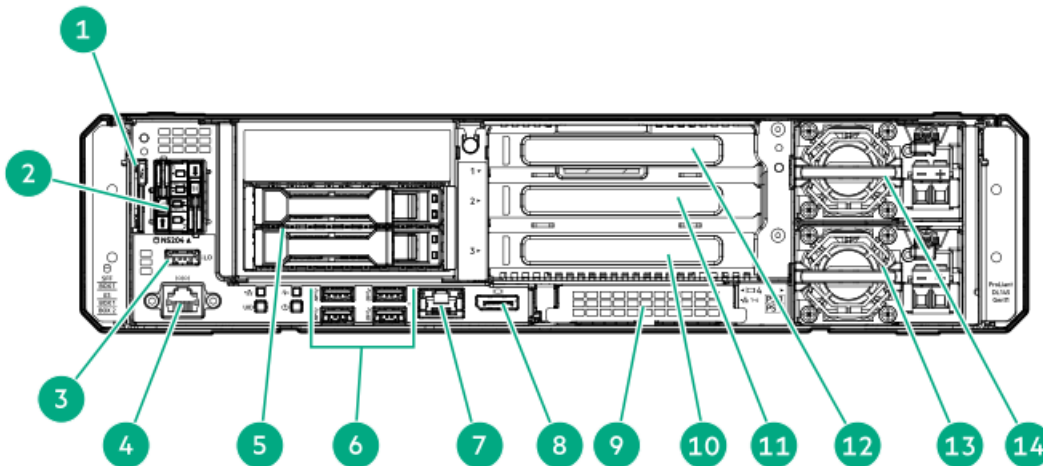

Item	Description
1	Serial number/iLO information pull tab ¹
2	HPE NS204i-u Boot Device (optional)
3	iLO service port
4	RJ45-serial port (optional)
5	2 SFF drives (optional) ²
6	USB 3.2 Gen 1 ports
7	iLO management port
8	DisplayPort 1.1a
9	Slot 21 OCP PCIe x16
10	Slot 3 PCIe x16 (base riser)
11	Slot 2 PCIe x16 (optional stacking riser)
12	Slot 1 PCIe x16 (optional stacking riser)
13	Flexible Slot power supply 2 (optional)
14	Flexible Slot power supply 1

¹ The serial number/iLO information pull tab is double-sided. One side shows the server serial number and the customer asset tag label. The other side shows the default iLO account information.

² The 2 SFF drive cage option supports SAS, SATA, or U.3 NVMe drives .

4 / 4 + 2 E3.S drive configuration

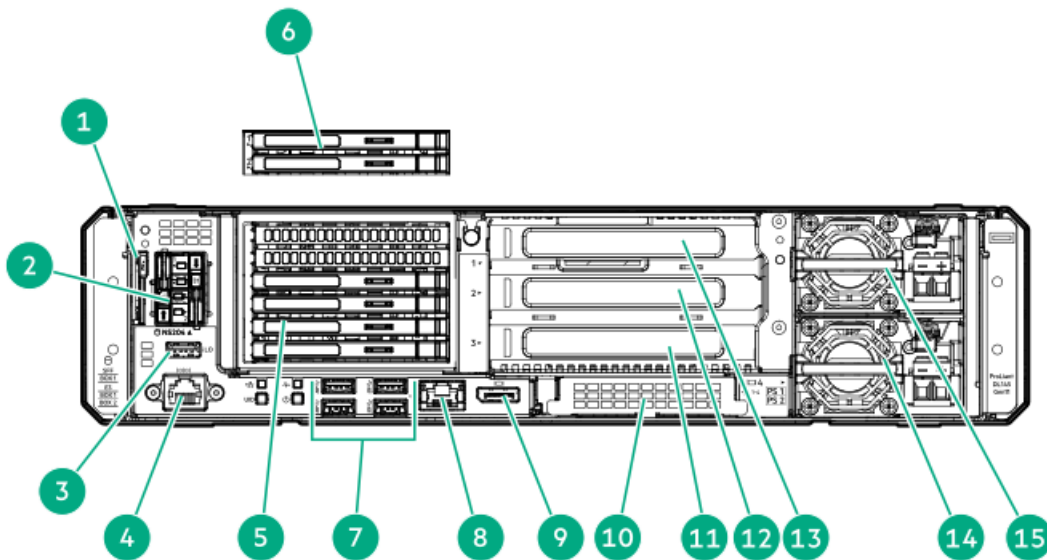

Item	Description
1	Serial number/iLO information pull tab ¹
2	HPE NS204i-u Boot Device (optional)
3	<u>iLO service port</u>
4	RJ45-serial port (optional)
5	4 E3.S drives (optional) ²
6	2 E3.S drives (optional) ²
7	USB 3.2 Gen 1 ports
8	iLO management port
9	<u>DisplayPort 1.1a</u>
10	Slot 21 OCP PCIe5 x16
11	Slot 3 PCIe5 x16 (base riser)
12	Slot 2 PCIe5 x16 (optional stacking riser)
13	Slot 1 PCIe5 x16 (optional stacking riser)
14	Flexible Slot power supply 2 (optional)
15	Flexible Slot power supply 1

¹ The serial number/iLO information pull tab is double-sided. One side shows the server serial number and the customer asset tag label. The other side shows the default iLO account information.

² The 6 E3.S stacked drive cage option supports NVMe drives.

Subtopics

[iLO Service Port](#)

[Display device setup](#)

iLO Service Port

The Service Port is a USB port with the label **iLO** on supported servers and compute modules.

To find out if your server or compute module supports this feature, see the server specifications document at the following website: <https://www.hpe.com/info/quickspecs>.

The Service Port is a USB port with the label **iLO** on the front of the server.

To find out if your server supports this feature, see the server specifications document at the following website: <https://www.hpe.com/info/quickspecs>.

When you have physical access to a server, you can use the Service Port to do the following:

- Download the Active Health System Log to a supported USB flash drive.
 - When you use this feature, the connected USB flash drive is not accessible by the host operating system.
- Connect a client (such as a laptop) with a supported USB to Ethernet adapter to access the following:
 - iLO web interface
 - Remote console
 - iLO RESTful API
 - CLI

When you use the iLO Service Port:

- Actions are logged in the iLO event log.

- The server UID flashes to indicate the Service Port status.

You can also retrieve the Service Port status by using a REST client and the iLO RESTful API.

- You cannot use the Service Port to boot any device within the server, or the server itself.
- You cannot access the server by connecting to the Service Port.
- You cannot access the connected device from the server.

Display device setup

This server supports DisplayPort 1.1a. Before connecting a display device to this server, review the following information:

- DisplayPort connection:

When connecting an HDMI or DVI display to the DisplayPort, use an active type adapter. Passive type adapter—marked with the DP++ symbol—is not supported.

- Display output modes:

The embedded video controller in the iLO 6 chipset does not support dual display or screen extension mode. To enable dual display mode, install a compatible PCIe5 graphics card that supports this feature in the expansion slot.

Front panel LEDs and buttons

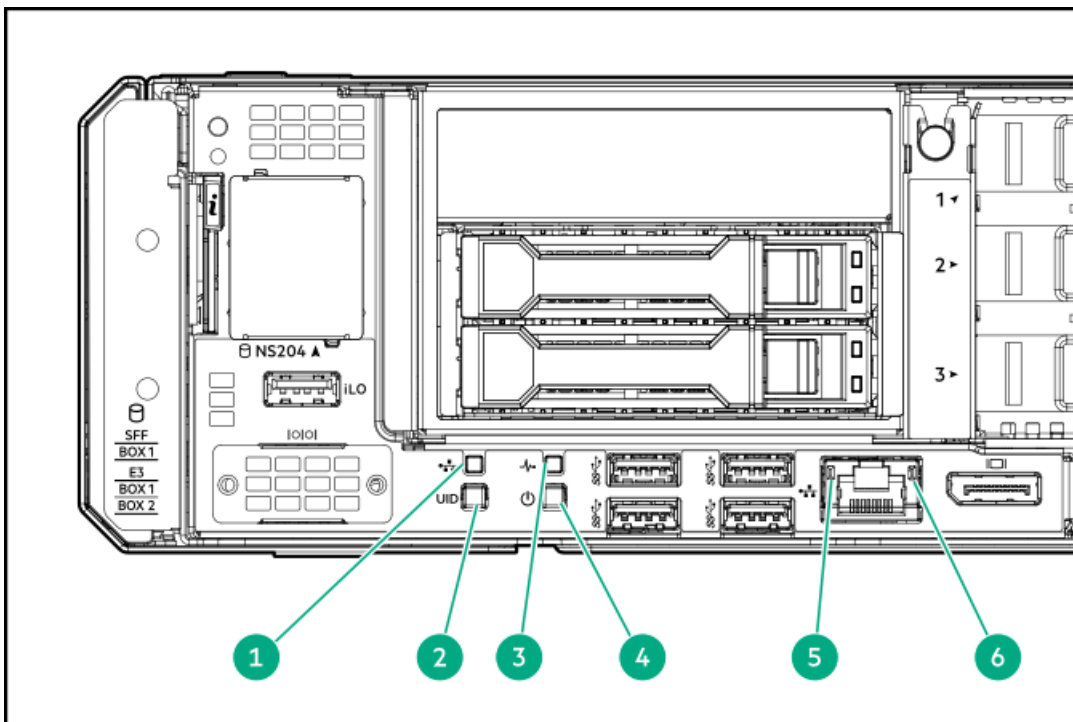

Item	Description	Status	Definition
1	NIC status LED ²	Solid green	Linked to network
		Flashing green	Network active
		Off	No network activity
2	UID button/LED ²	Solid blue	Activated
		Flashing blue	<ul style="list-style-type: none"> 1 flash per second—Remote management or firmware upgrade in progress 4 flashes per second—iLO manual reboot sequence initiated 8 flashes per second—iLO manual reboot sequence in progress
		Off	Deactivated
		Off	Deactivated
3	Health LED ²	Solid green	Normal
		Flashing green	iLO is rebooting
		Flashing amber	System degraded ¹
		Flashing red	System critical ¹
4	Power On/Standby button and system power LED ²	Solid green	System on
		Flashing green	Performing power-on sequence
		Solid amber	System in standby
		Off	No power present ³
5	NIC/iLO link	Solid green	Network link speed is 1000 Mb/s.
		Solid amber	Network link speed is 10/100 Mb/s.
		Off	No network link
6	NIC/iLO activity	Flashing green	Network active
		Off	No network activity

¹ If the health LED indicates a degraded or critical state, [review the system Integrated Management Log \(IML\)](#) or use [HPE iLO to review the system health status](#).

² When all LEDs flash simultaneously, a power fault has occurred. For more information, see [Front panel LED power fault codes](#).

³ Facility power is not present, power cord is not attached, no power supplies are installed, power supply failure has occurred, or the front I/O cable is disconnected.

Subtopics

[Server UID LED](#)

[Using the UID button to view the Server Health Summary](#)

[Front panel LED power fault codes](#)

Server UID LED

The UID LED can be used to help an on-site technician quickly identify or locate a particular server when it is deployed in a dense rack with other equipment. It can also be used to identify if a remote management, firmware upgrade, or reboot sequence is in progress.

Using the UID button to view the Server Health Summary



Prerequisites

- An external monitor is connected.
- In the iLO web interface, the Show Server Health on External Monitor feature is enabled on the Access Settings page.

About this task

Use the UID button to display the iLO Server Health Summary screen on an external monitor. This function works when the server is powered on or off. Use this feature for troubleshooting if the server will not start up.



CAUTION

Press and release the UID button. Holding it down at any time for more than five seconds initiates a graceful iLO reboot or a hardware iLO reboot. Data loss or NVRAM corruption might occur during a hardware iLO reboot.

Procedure

1. Press and release the UID button.

The Server Health Summary screen is displayed on the external monitor. For more information, see the iLO troubleshooting guide:

<https://www.hpe.com/support/hpeilodocs-quicklinks>

2. Press the UID button again to close the Server Health Summary screen.

Front panel LED power fault codes

The following table provides a list of power fault codes, and the subsystems that are affected. Not all power faults are used by all servers.

Subsystem	LED behavior
System board	1 flash
Processor	2 flashes
Memory	3 flashes
Riser board PCIe slots	4 flashes
FlexibleLOM	5 flashes
Storage controller	6 flashes
System board PCIe slots	7 flashes
Power backplane	8 flashes
Storage backplane	9 flashes
Power supply	10 flashes
PCIe expansion cards installed in riser board	11 flashes
Chassis	12 flashes
GPU card	13 flashes

Component touchpoints

Certain components are color-coded. These colors represent the recommended touch areas for a removal process and indicate whether components require a system shutdown before removal.

The following diagrams are examples only.



HPE hot-plug red

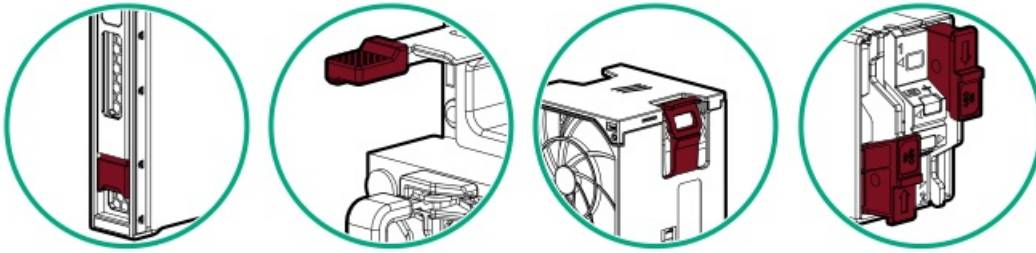

Hot-plug red indicates hot-pluggable components. These components can be removed and installed while the system is running, and doing so will not result in a system shutdown.

Component examples:

- Power supplies in a redundant power configuration
- Hot-plug fans
- Hot-plug drives
- M.2 SSDs in a hot-plug boot device

HPE touchpoint blue

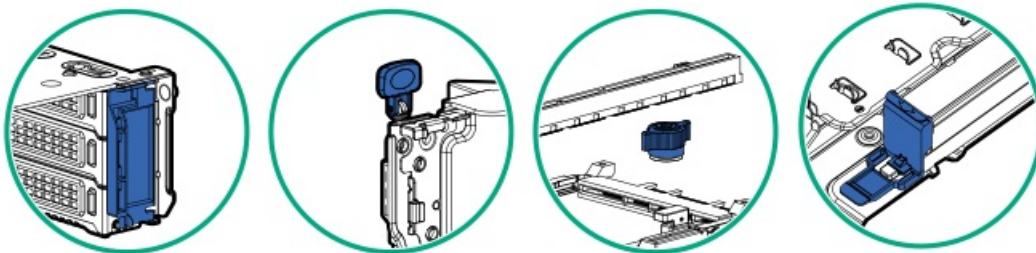

Touchpoint blue indicates cold-pluggable components. These components require a system shutdown. Failure to do so might result in system failure or data loss. Cold-pluggable components might also indicate touchpoints on non-electrical components.

Component examples:

- Storage devices
- Fan cages
- System boards
- Energy packs

System board components

The grayed out components in the system board image are not for use in this server.



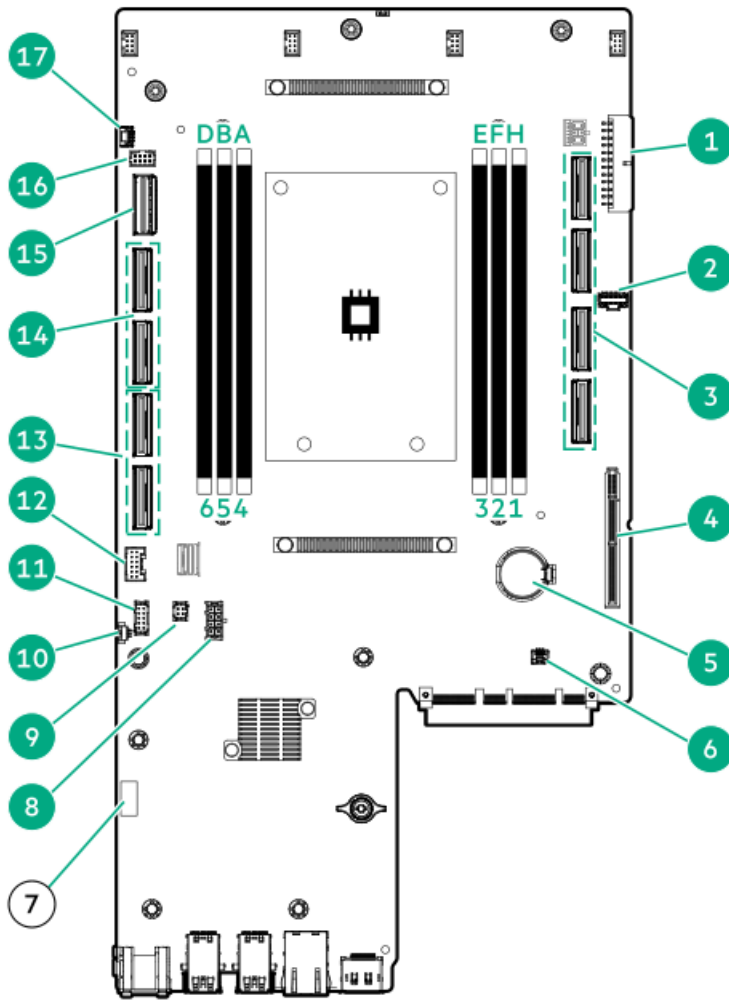

Item	Description
1	System board power connector
2	Sideband connector for the power supply
3	NVMe ports 3A–6A (from top to bottom)
4	Riser connector
5	System battery
6	Storage backup power connector
7	<u>System maintenance switch</u>
8	Drive backplane power connector
9	iLO service port connector
10	Remote temperature sensor connector
11	RJ45-serial port connector
12	Energy pack connector
13	MCIO ports 8A–7A (from top to bottom)
14	NVMe ports 2A–1A (from top to bottom) ¹
15	NS204i-u signal connector
16	M.2 SSD power connector ²
17	Chassis intrusion detection switch connector

¹ NVMe port 1A supports NVMe and SATA.
² This power connector is for the HPE NS204i-u Boot Device option.

Subtopics

[System maintenance switch descriptions](#)

[DIMM label identification](#)

[DIMM slot numbering](#)

[Processor and socket components](#)

System maintenance switch descriptions

Position	Default	Function
S1 ¹	Off	<ul style="list-style-type: none">Off—iLO 6 security is enabled.On—iLO 6 security is disabled.
S2	Off	Reserved
S3	Off	Reserved
S4	Off	Reserved
S5 ¹	Off	<ul style="list-style-type: none">Off—Power-on password is enabled.On—Power-on password is disabled.
S6 ^{1, 2, 3}	Off	<ul style="list-style-type: none">Off—No functionOn—Restore default manufacturing settings
S7	Off	Reserved
S8	Off	Reserved
S9	Off	Reserved
S10	Off	Reserved
S11	Off	Reserved
S12	Off	Reserved

¹ To access the redundant ROM, set S1, S5, and S6 to On.

² When the system maintenance switch position 6 is set to the On position, the system is prepared to restore all configuration settings to their manufacturing defaults.

³ When the system maintenance switch position 6 is set to the On position and Secure Boot is enabled, some configurations cannot be restored. For more information, see [Configuring the server](#).

DIMM label identification

To determine DIMM characteristics, see the label attached to the DIMM. The information in this section helps you to use the label to locate specific information about the DIMM.

For more information about product features, specifications, options, configurations, and compatibility, see the [HPE DDR5 SmartMemory QuickSpecs](#):

<https://www.hpe.com/docs/server-memory>

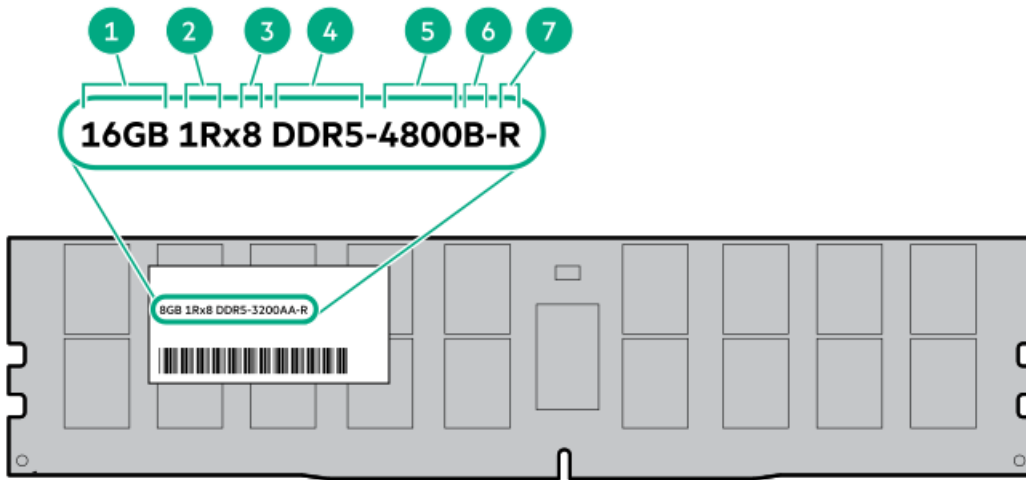

Item	Description	Example
1	Capacity *	16 GB 32 GB 64 GB 128 GB
2	Rank	1R—Single rank 2R—Dual rank
3	Data width on DRAM	x4—4-bit x8—8-bit
4	Memory generation	PC5—DDR5
5	Maximum memory speed *	4800 MT/s
6	CAS latency	B—42-42-42 B—50-42-42 (for 128 GB capacity)
7	DIMM type	R—RDIMM (registered)

* The maximum memory speed and capacity is a function of the memory type, memory configuration, and processor model.

DIMM slot numbering

The arrow points to the front of the server.

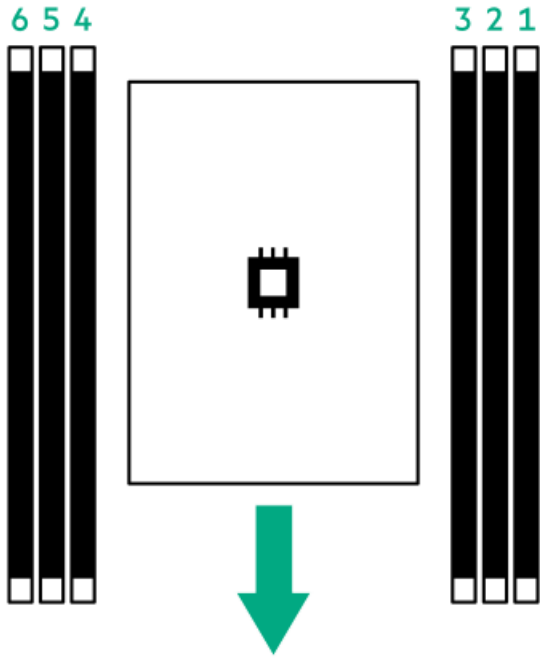

Processor and socket components

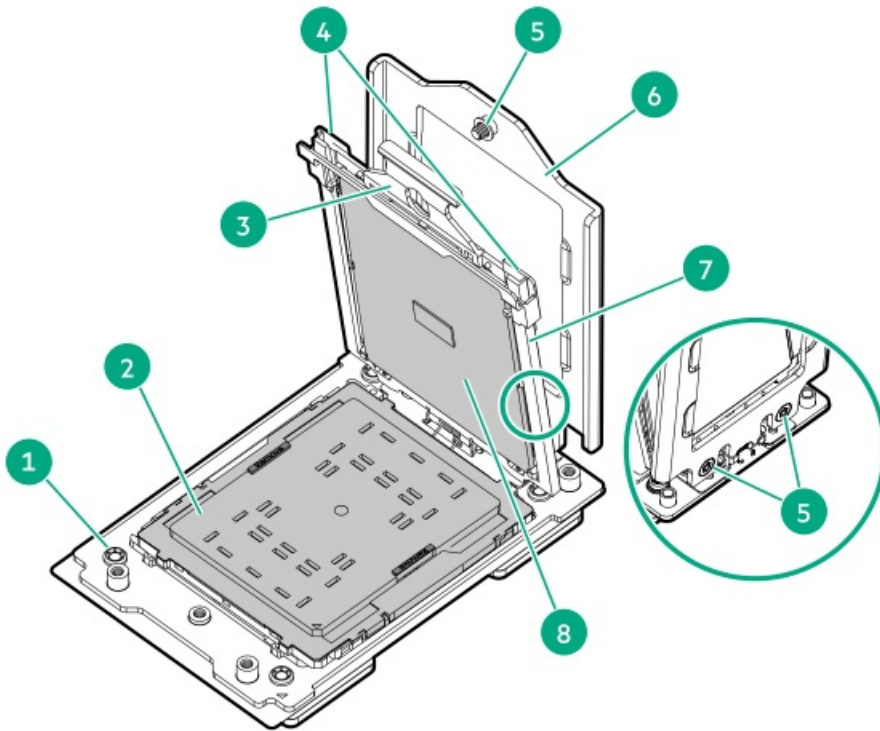

Item	Description
1	Processor socket
2	Pin field cover cap
3	Processor carrier
4	Rail frame lift tabs
5	Retention frame screws (T-20)
6	Retention frame
7	Rail frame
8	Processor

Riser board components

This server supports two general types of PCIe risers:

- Standard riser—This riser is a board-only riser that is installed in a three-slot riser cage by default. This riser type is used:
 - As a standalone riser in a three-slot riser cage.
 - As the base riser in a three-slot riser cage.
- Cabled riser—This riser type has its signal cable soldered on the board itself. This riser type is combined with a standard, base riser and another cabled riser in a three-slot riser cage.

For clarity, the riser cage and the cables of the cabled risers are not always shown in the following images.

Standard riser components

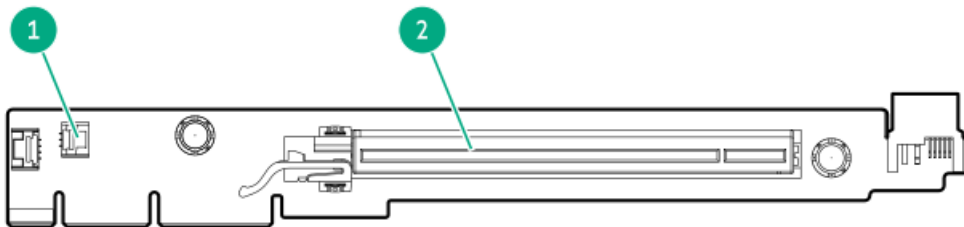

Item Description

- | | |
|---|---|
| 1 | Storage controller backup power connector |
| 2 | PCIe5 x16 (16, 8, 4, 1) slot |

Cabled riser components

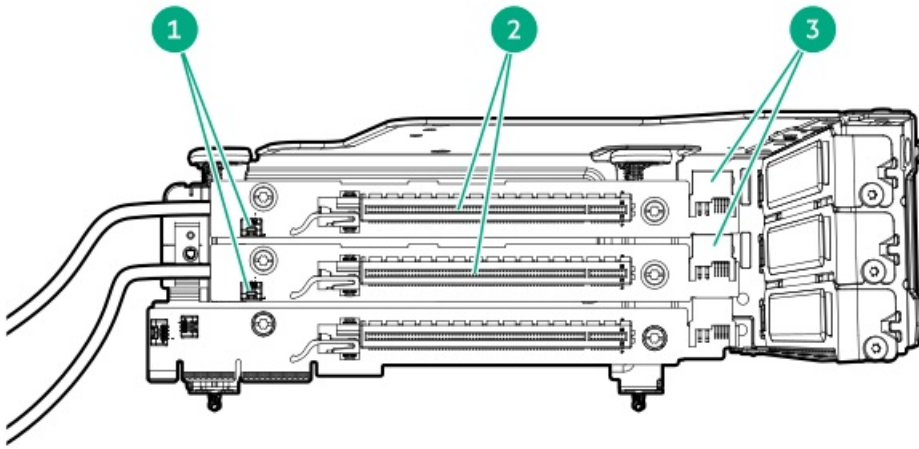

Item Description

- | | |
|---|--|
| 1 | Storage controller backup power connectors |
| 2 | PCIe5 x16 (16, 8, 4, 1) slots |
| 3 | Riser power connectors |

Riser slot numbering

All riser slots are PCIe5 x16 (16, 8, 4, 1) and are rated for a maximum power draw of 75 W each.

Three-slot riser configuration with optional cabled stacking risers

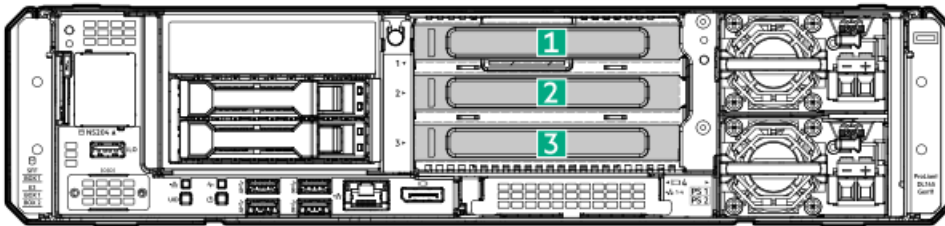

Slot number	Location	Description	Supported form factors
1	Three-slot riser cage	Stacking cabled riser (optional)	<ul style="list-style-type: none"> Full-height, full-length * Full-height, half-length Half-height, half-length (low-profile)
2		Stacking cabled riser (optional)	<ul style="list-style-type: none"> Full-height, full-length * Full-height, half-length Half-height, half-length (low-profile)
3		Base riser	<ul style="list-style-type: none"> Full-height, half-length Half-height, half-length (low-profile)

* Some options are required to support full-size cards. For more information, see the product QuickSpecs on the Hewlett Packard Enterprise website (<https://www.hpe.com/info/quickspecs>).

3 single-width GPU configuration

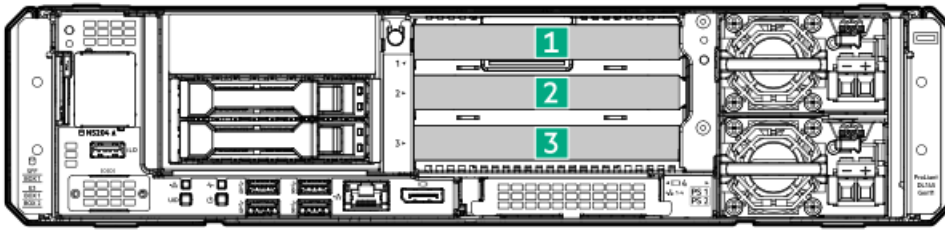

Slot number	Location	Description	Supported form factors
1	Three-slot riser cage	GPU	Single-width, half-height, half-length (low-profile)
2		GPU	
3		GPU	

2 single-width GPU configuration

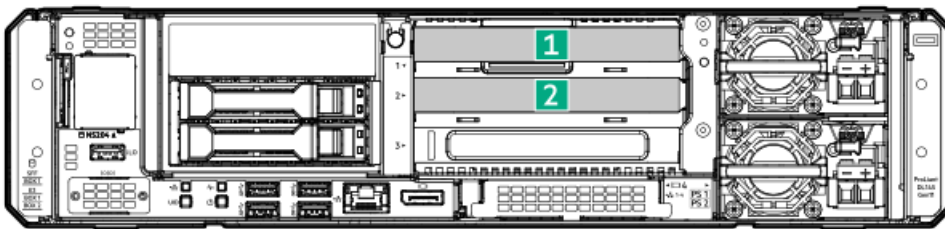

Slot number	Location	Description	Supported form factors
1	Three-slot riser cage	GPU	Single-width, half-height, half-length (low-profile)
2		GPU	
3		Type-p storage controller	

HPE Basic Drive LED definitions

The HPE Basic drive carrier has the following LEDs:

- Amber/blue LED—Managed by the drive backplane in conjunction with the storage controller and is used to indicate drive status.
- Green LED—Managed by the drive itself and indicates the drive activity.

SFF basic drive carrier

The SFF basic drive carrier supports hot-plug SAS, SATA, or U.3 NVMe drives .



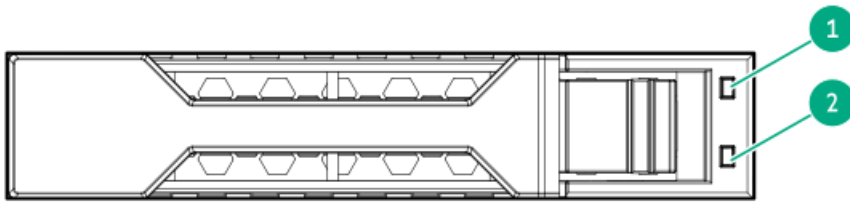

Item	LED	State	Definition
1	Fault/Locate	Solid amber	This drive has failed, is unsupported, or is invalid.
		Solid blue	The drive is operating normally and being identified by a management application.
		Flashing amber/blue (1 flash per second)	The drive has failed, or a predictive failure alert has been received for this drive. The drive has also been identified by a management application.
		Flashing amber (1 flash per second)	A predictive failure alert has been received for this drive. Replace the drive as soon as possible.
		Off	The drive is operating normally and not being identified by a management application.
2	Online/Activity	Solid green	The drive is online and has no activity.
		Flashing green (1 flash per second)	The drive is doing one of the following: <ul style="list-style-type: none"> Rebuilding or performing a RAID Performing a stripe size migration Performing a capacity expansion Performing a logical drive extension Erasing Spare part activation
		Flashing green (4 flashes per second)	The drive is operating normally and has activity.
		Off	The drive is not configured by a RAID controller or is a spare drive.

EDSFF SSD LED definitions

The EDSFF drive carrier has two LEDs:

- Amber/blue LED—Managed by the drive backplane in conjunction with the storage controller and is used to indicate drive status.
- Green LED—Managed by the drive itself and indicates the drive activity.

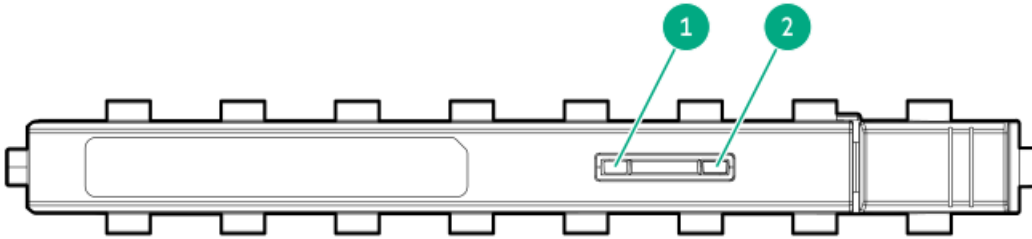

Item	LED	State	Definition
1	Fault/Locate	Solid amber	This drive has failed, is unsupported, or is invalid.
		Solid blue	The drive is operating normally and being identified by a management application.
		Flashing amber/blue (1 flash per second)	The drive has failed, or a predictive failure alert has been received for this drive. The drive has also been identified by a management application.
		Flashing amber (1 flash per second)	A predictive failure alert has been received for this drive. Replace the drive as soon as possible.
		Off	The drive is operating normally and not being identified by a management application.
2	Online/Activity	Solid green	The drive is online and has no activity.
		Flashing green (4 flashes per second)	The drive is operating normally and has activity.
		Off	No power present.

Drive bay numbering



CAUTION

When a server is purchased without any drive installed, some drive bays might be empty while other drive bays might be populated with drive blanks. To maintain proper system cooling, do not operate the server without a drive or a drive blank installed.

Subtopics

[SFF drive bay numbering](#)

[E3.S drive bay numbering](#)

SFF drive bay numbering

The following drive backplane options are supported in the 2 SFF drive configuration:

- 32G x4 U.3 NVMe / SAS / SATA UBM3 BC
- 24G x4 U.3 NVMe / SAS / SATA UBM6 BC

For more information on the drive backplane description, see [Drive backplane naming](#).

2 SFF drive bay numbering

Rack orientation



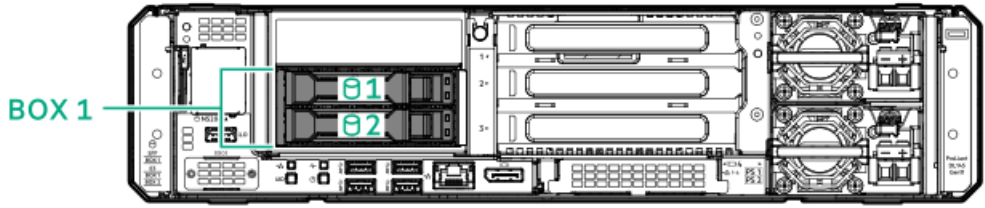

Wall mount orientation

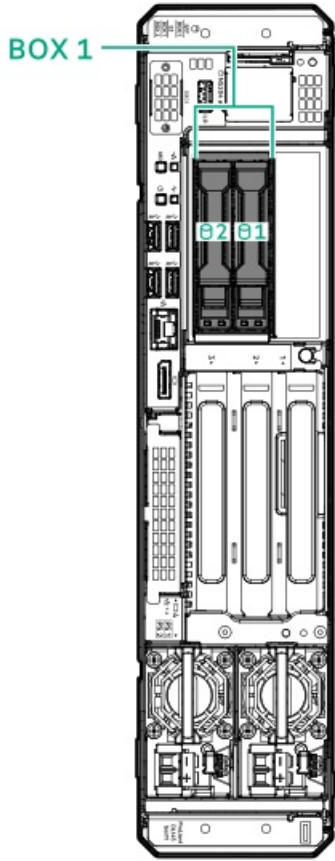

E3.S drive bay numbering

The E3.S drive box supports 4 E3.S or 4 + 2 E3.S drives.

The following drive backplane and cable options are supported in 4 E3.S drive configuration:

- Direct attach options:
 - Backplane: 4 E3.S 32G x4 NVMe UBM10 EC1
 - 4 E3.S direct attached cable from Box 2 to system board
- Storage controller options:
 - Backplane: 4 E3.S 32G x4 NVMe UBM10 EC1
 - 4 E3.S SlimSAS cable from Box 2 to storage controller

The following drive backplane and cable options are supported in 4 + 2 E3.S drive configuration:

- Direct attach options:



- Backplane: 4 E3.S 32G x4 NVMe UBM10 EC1
- 2 E3.S direct attached cable from Box 1 to system board
- 4 E3.S direct attached cable from Box 2 to system board
- Storage controller options:
 - Backplane: 4 E3.S 32G x4 NVMe UBM10 EC1
 - 2 E3.S SlimSAS cable from Box 1 to storage controller
 - 4 E3.S SlimSAS cable from Box 2 to storage controller

For more information on the drive backplane description, see [Drive backplane naming](#).

4 E3.S drive bay numbering

Rack orientation

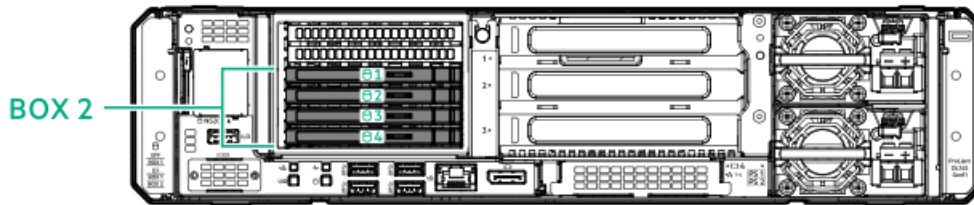

Wall mount orientation

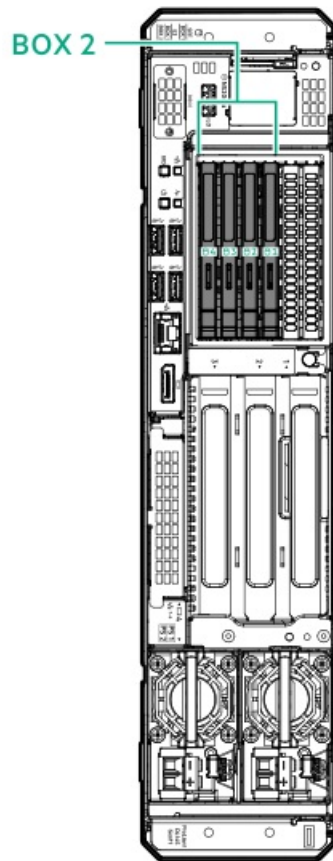

4 + 2 E3.S drive bay numbering

Rack orientation



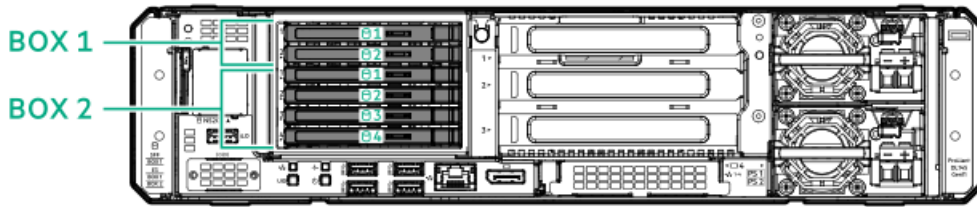

Wall mount orientation

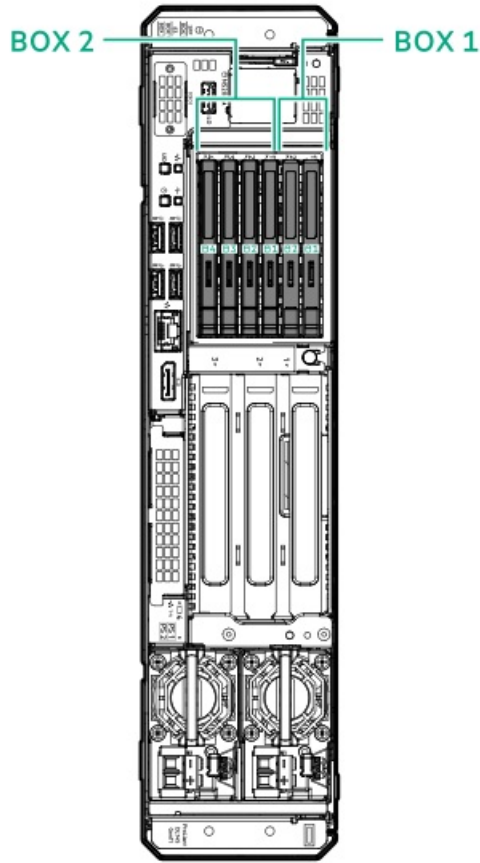

Drive backplane naming

This topic explains the features represented in the drive backplane naming. This naming convention was adopted starting in the HPE Gen11 server release. Your server might not support all the features listed in this topic. For server-specific support information, see the server guides:

- Drive backplane support, see [Drive bay numbering](#).
- Drive backplane cabling, see [Storage cabling](#).



Item	Description	Values
1	Drive bay count	Number of drive bays supported by the backplane.
2	Drive form factor	LFF—Large Form Factor SFF—Small Form Factor E3S—Enterprise and Datacenter Standard Form Factor (EDSFF E3.S)
3	Maximum link rate per lane (GT/s)	12G 16G 24G 32G
4	Port link width and interface	x1 NVMe/SAS—U.3 NVMe, SAS, or SATA ¹ x4 NVMe/SAS—U.3 NVMe, SAS, or SATA ² x4 NVMe—U.2 NVMe ³ x4 NVMe—E3.S
5	Universal backplane manager (UBM) model	The UBM model defines the UBM firmware used by the backplane. Examples of UBM models: UBM2, UBM3, etc.
6	Drive carrier type	BC—Basic carrier (SFF) LP—Low-profile carrier (LFF) EC—E3.S carrier

¹ Tri-mode controller support for x1 U.3 NVMe, SAS, and SATA drives. System board connection supports SATA drives only (not available on Gen12).

² CPU direct attach or tri-mode controller support for x4 U.3 NVMe, x2 (via a splitter cable) U.3 NVMe, or x1 SAS and SATA drives.

³ CPU direct attach or tri-mode controller support for x4 U.2 NVMe drives.

GPU numbering

3 single-width GPUs

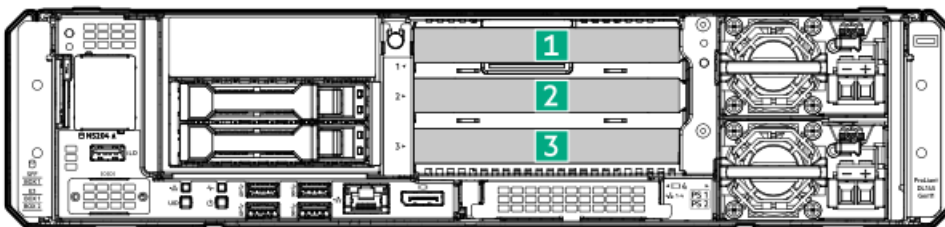

2 single-width GPUs

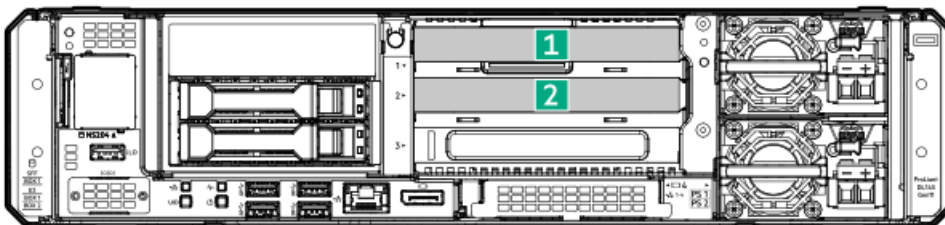

Power distribution board (PDB) components

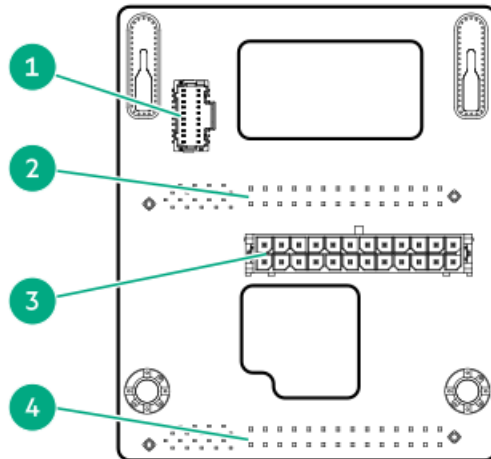

Item	Description	Connect to
1	Power supply sideband connector	System board: power supply sideband connector
2	Power supply connector 1 *	Power supply
3	System board power connector	System board: system board power connector
4	Power supply connector 2 *	Power supply

* The connector is on the backside of the power distribution board.

Fan numbering

To provide sufficient airflow to the system, the server is by default populated by four fans. The fans can either be standard, single-rotor fans (P72586-B21) or high performance, single-rotor fans (P72581-B21). Mixed fan configuration is not supported.

The arrow points to the front of the server.

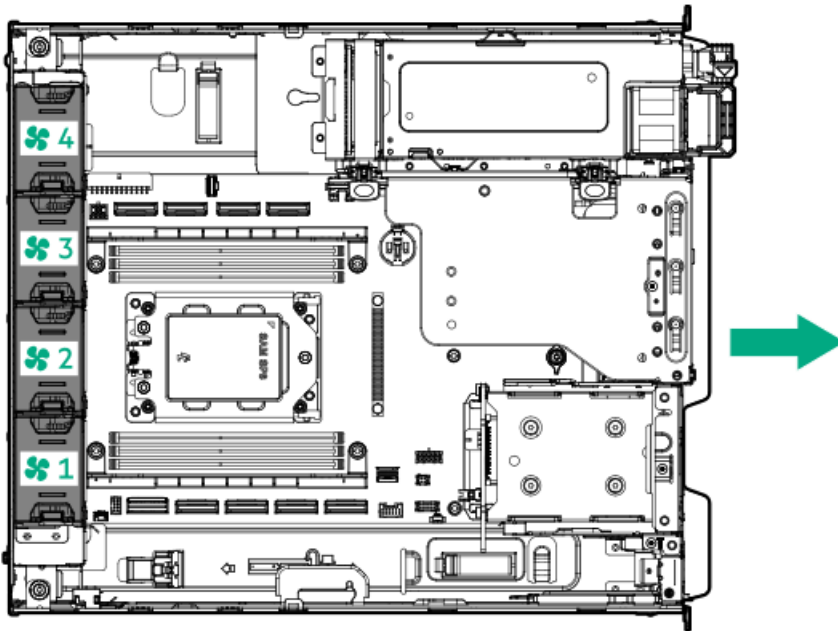

Subtopics

Fan and heatsink requirements

Fan and heatsink requirements



CAUTION

To maintain proper system cooling, install the correct fan and heatsink types required for specific hardware configurations.

SFF/E3.S drive configuration

The information in this section is valid for up to the maximum 2 SFF, and 6 E3.S drive configurations. All fan bays need to be populated.

Drive configuration	Fan 1–4
2 SFF	Standard fan ¹
4 E3.S, or 6 E3.S	High performance fan ²

- ¹ Option kit: P72586-B21
² Option kit: P72581-B21

Trusted Platform Module 2.0

The Trusted Platform Module 2.0 (TPM) is a hardware-based system security feature that securely stores artifacts used to authenticate the platform. These artifacts can include passwords, certificates, and encryption keys.

The TPM 2.0 is embedded on the server system board.

The TPM 2.0 is supported with specific operating system support such as Microsoft Windows Server 2012 R2 and later. For more information about operating system support, see the product QuickSpecs on the Hewlett Packard Enterprise website (<https://www.hpe.com/info/quickspecs>). For more information about Microsoft Windows BitLocker Drive Encryption feature, see the

Subtopics

[Trusted Platform Module 2.0 guidelines](#)

[BitLocker recovery key/password retention guidelines](#)

Trusted Platform Module 2.0 guidelines



CAUTION

- Always observe the TPM guidelines in this section. Failure to follow these guidelines can cause hardware damage or halt data access.
- If you do not follow procedures for modifying the server and suspending or disabling the TPM in the OS, an OS that is using TPM might lock all data access. This includes updating system or option firmware, replacing hardware such as the system board and drives, and modifying TPM OS settings.
- Changing the TPM mode after installing an OS might cause problems, including loss of data.

Hewlett Packard Enterprise SPECIAL REMINDER: Before enabling TPM functionality on this system, you must ensure that your intended use of TPM complies with relevant local laws, regulations and policies, and approvals or licenses must be obtained if applicable.

慧与特别提醒：在您启用系统中的TPM功能前，请务必确认您对TPM的使用遵守当地相关法律、法规及政策，并已事先获得所需的一切批准及许可（如适用），因您未获得相应的操作/使用许可而导致的违规问题，皆由您自行承担全部责任，与慧与无涉。

- When the embedded TPM is enabled, the Trusted Platform Module operates in TPM 2.0 mode.
- Use the UEFI System Utilities to configure the TPM. From the System Utilities screen, select System Configuration > BIOS/Platform Configuration (RBSU) > Server Security > Trusted Platform Module options. For more information, see the UEFI user guide:
<https://www.hpe.com/support/UEFIgen11-UG-en>
- When using the Microsoft Windows BitLocker Drive Encryption feature, always retain the recovery key or password. The recovery key or password is required to enter Recovery Mode after BitLocker detects a possible compromise of system integrity.
- HPE is not liable for blocked data access caused by improper TPM use. For operating instructions, see the documentation for the encryption technology feature provided by the operating system.

BitLocker recovery key/password retention guidelines

The recovery key/password is generated during BitLocker setup, and can be saved and printed after BitLocker is enabled. When using BitLocker, always retain the recovery key/password. The recovery key/password is required to enter Recovery Mode after BitLocker detects a possible compromise of system integrity.

To help ensure maximum security, observe the following guidelines when retaining the recovery key/password:

- Always store the recovery key/password in multiple locations.
- Always store copies of the recovery key/password away from the server.
- Do not save the recovery key/password on an encrypted drive.

HPE NS204i-u Boot Device components

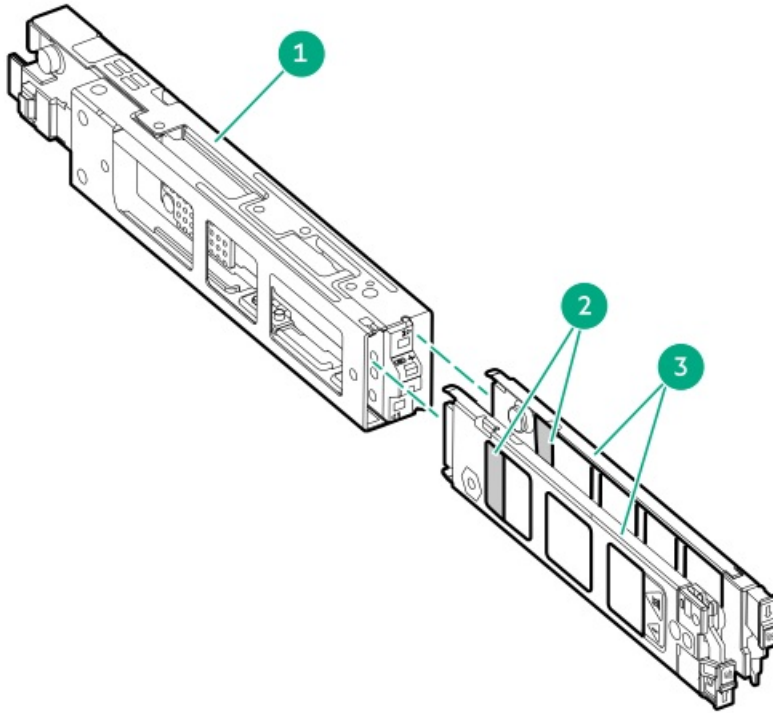

Item	Description
1	Boot device cage
2	M.2 slots
3	Boot device carriers

HPE NS204i-u Boot Device LED definitions

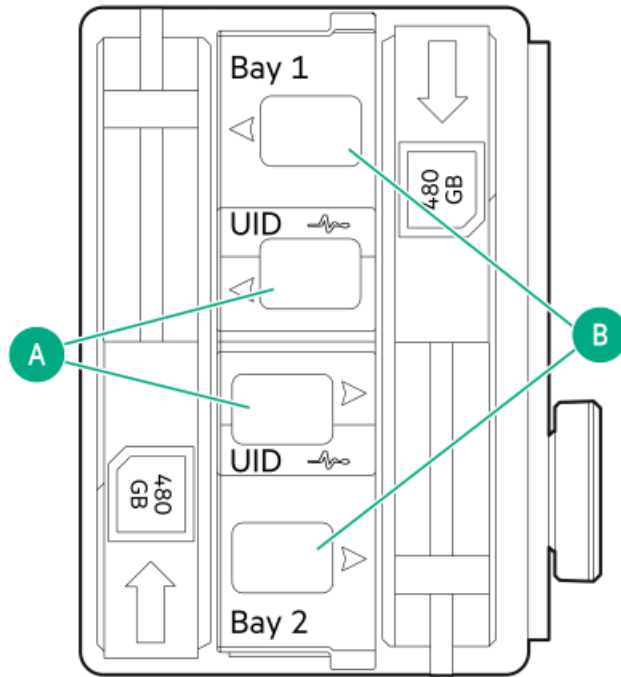

NOTE

The bay number can be found on the SSD carrier handle.

Item	LED	Status	Definition
A	Fault or Locate	Solid amber	Drive has failed, unsupported, or invalid.
		Solid blue	Drive is operating normally.
		Flashing amber or blue (one flash per second)	Drive has failed, or a predictive failure alert is received for the drive.
		Flashing amber (one flash per second)	Drive predictive failure alert is received. Replace the drive as soon as possible.
		Off	Drive is operating normally and is not identified by any application.
B	Online/Activity	Solid green	Drive is online and has no activity.
		Flashing green (one flash per second)	Drive is doing one of the following: <ul style="list-style-type: none"> Rebuilding or performing a RAID Erasing
		Flashing green (4 flashes per second)	Drive is operating normally and has activity.
		Off	Drive is not configured by a RAID controller.

Setup

This chapter describes general operational requirements and safety reminders, as well as the initial setup procedure for the server.

Subtopics

[Initial system installation](#)

[Operational requirements](#)



[Rack warnings and cautions](#)
[Server warnings and cautions](#)
[Electrostatic discharge](#)

Initial system installation

Depending on your technical expertise and the complexity of the product, for the initial system installation, select one of the following options:

- [Ordering the HPE Installation Service](#)
- [Setting up the server](#)

Subtopics

[HPE Installation Service](#)
[Setting up the server](#)

HPE Installation Service

HPE Installation Service provides basic installation of Hewlett Packard Enterprise branded equipment, software products, as well as HPE-supported products from other vendors that are sold by HPE or by HPE authorized resellers. The Installation Service is part of a suite of HPE deployment services that are designed to give users the peace of mind that comes from knowing that their HPE and HPE-supported products have been installed by an HPE specialist.

The HPE Installation Service provides the following benefits:

- Installation by an HPE authorized technical specialist.
- Verification prior to installation that all service prerequisites are met.
- Delivery of the service at a mutually scheduled time convenient to your organization.
- Allows your IT resources to stay focused on their core tasks and priorities.
- Full coverage during the warranty period for products that require installation by an HPE authorized technical specialist.

For more information on the features, limitations, provisions, and ordering information of the HPE Installation Service, see this Hewlett Packard Enterprise website:

<https://www.hpe.com/support/installation-service>

Setting up the server

Prerequisites

- As a best practice, Hewlett Packard Enterprise recommends installing the latest firmware, drivers, and system software before using the server for the first time. You have these options:
 - HPE Compute Ops Management is an advanced software-as-a-service platform that securely streamlines operations from edge-to-cloud and automates key life cycle tasks through a unified single browser-based interface. For more information on using HPE Compute Ops Management, see <https://www.hpe.com/support/hpe-gl-com-quicklinks>.
 - Use the Firmware Update option in Intelligent Provisioning—Intelligent Provisioning is a server deployment tool embedded in HPE ProLiant servers. To access Intelligent Provisioning, during the server boot process, press **F10**. For more information, see the Intelligent Provisioning user guide at <https://www.hpe.com/support/hpeintelligentprovisioning-quicklinks>.

- Download the Service Pack for ProLiant (SPP) —SPP is a comprehensive system software and firmware update solution that is delivered as a single ISO image. This solution uses Smart Update Manager (SUM) as the deployment tool.
 - The preferred method for downloading an SPP is by creating an SPP custom download at <https://www.hpe.com/servers/spp/custom>.
This option reduces the size of the SPP by excluding firmware and drivers for OS and server models that are not needed.
 - The SPP is also available for download from the SPP download page at <https://www.hpe.com/servers/spp/download>.
- Verify that your OS or virtualization software is supported:
<https://www.hpe.com/support/Servers-Certification-Matrices>
- Read the [Operational requirements](#) for the server.
- Read the safety and compliance information:
<https://www.hpe.com/support/safety-compliance-enterpriseproducts>
- Take note of the iLO hostname and default login credentials on the [serial number/iLO information pull tab](#).

Procedure

1. Unbox the server and verify the contents:

- Server
- Power cord
- Mounting hardware (optional)
- Documentation

The server does not ship with OS media. All system software and firmware is preloaded on the server.

2. (Optional) [Install the hardware options](#).

3. (Optional) Install one of the following mounting hardware options:

- [Rack mounting hardware](#)
- [Wall mounting or desktop installation hardware](#)

4. (Optional) If the rack mounting hardware is installed, [install the server into the rack \(friction rack rail\)](#).

5. Decide how to manage the server:

- Locally: Use a KVM switch, or connect a keyboard, monitor, and mouse.
- Remotely: Connect to the iLO web interface and run a remote console:

a. Verify the following:

- iLO is licensed to use the remote console feature.
If iLO is not licensed, visit the HPE website:

<https://www.hpe.com/info/ilo>

- The iLO management port is connected to a secure network.

b. Using a browser, navigate to the iLO web interface, and then log in.

`https://<iLO hostname or IP address>`

Note the following:

- If a DHCP server assigns the IP address, the IP address appears on the boot screen.
- If a static IP address is assigned, use that IP address.

c. Enter the iLO login name and password, and then click Log In.

- d. In the navigation tree, click the [Remote Console & Media](#) link, and then launch a remote console.
6. (Optional) if the front bezel option is installed, [remove the front bezel](#).
7. Press the Power On/Standby button.
For remote management, use the iLO virtual power button.
8. [Configure the initial server setup](#).
9. [Set up the storage](#).
10. [Deploy an OS or virtualization software](#).
11. After the OS is installed, [update the drivers](#).
12. [Register the server](#).

Operational requirements

When preparing and planning the installation, observe the following operational requirements:

- [Space and airflow requirements](#)
- [Temperature requirements](#)
- [Power requirements](#)
- [Electrical grounding requirements](#)

For environmental requirements, see [Environmental specifications](#).

Subtopics

[Space and airflow requirements](#)

[Temperature requirements](#)

[Power requirements](#)

[Electrical grounding requirements](#)

Space and airflow requirements

Rack mounting

To allow for servicing and adequate airflow, observe the following space and airflow requirements when installing the server in an indoor commercial rack:

- 63.50 cm (25.00 in) in front of the rack
- 76.20 cm (30.00 in) behind the rack
- 121.90 cm (48.00 in) from the back of the rack to the back of another rack or row of racks

Observe the following:

- Servers draw in cool air through the front of the rack and expel warm air through the rear. The front and rear rack doors must be adequately ventilated to allow ambient air to enter the cabinet. The rear door must be adequately ventilated to allow the warm air to escape from the cabinet.





CAUTION

To prevent improper cooling and damage to the equipment, do not block the ventilation openings.



CAUTION

When the vertical space in the rack is not filled by a server or rack component, the gaps between the components can cause changes in airflow through the rack and around the servers. Cover all gaps with blanking panels to maintain proper airflow. Using a rack without blanking panels results in improper cooling which can lead to thermal damage.

- If a third-party rack is used, observe the following additional requirements to ensure adequate airflow and prevent damage to the equipment:
 - Front and rear doors—If the 42U rack includes closing front and rear doors, you must allow 5,350 sq cm (830 sq in) of holes evenly distributed from top to bottom to permit adequate airflow (equivalent to the required 64 percent open area for ventilation).
 - Side—The clearance between the installed rack component and the side panels of the rack must be a minimum of 7.00 cm (2.75 in).

Wall mounting / desktop installation

To allow for servicing and adequate airflow, observe the following space and airflow requirements when installing the server on a wall or desk:

- Make sure that there is a minimum clearance of 20.00 cm (7.87 in) around the ventilation openings. Never cover these openings with any type of materials.

The server draws in cool air through the ventilation openings on the front and expels warm air through the ventilation openings on the back. Do not block these openings. Failure to observe this caution will result in improper airflow and insufficient cooling that can lead to thermal damage.

Temperature requirements

To ensure continued safe and reliable equipment operation, install or position the system in a well-ventilated, climate-controlled environment.

The maximum recommended ambient operating temperature (TMRA) for most server products is 35°C (95°F). The temperature in the room where the rack is located must not exceed 35°C (95°F).



CAUTION

To reduce the risk of damage to the equipment when installing third-party options:

- Do not permit optional equipment to impede airflow around the server or to increase the internal rack temperature beyond the maximum allowable limits.
- Do not exceed the manufacturer's TMRA.

Subtopics

[Extended ambient operating support](#)

Extended ambient operating support

Depending on the approved hardware configurations, the server supports extended operating temperatures up to 45°C, comparable to



ASHRAE A3 and A4 classes. With limited configuration options, the server supports an operating temperature up to 55°C (131°F).

Ambient temperature ranges

- Operating:
 - Extended ambient 40°C Support (ASHRAE Class A3 compliant):
5° to 40°C (41° to 104°F), with an altitude derating of 1.0°C per every 175 m (1.8°F per every 574 ft) above 900 m (2,953 ft) to a maximum of 3050 m (10,000 ft).
 - Extended ambient 45°C Support (ASHRAE Class A4 compliant):
5° to 45°C (41° to 113°F), with an altitude derating of 1.0°C per every 125 m (1.8°F per every 410 ft) above 900 m (2,953 ft) to a maximum of 3050 m (10,000 ft).
- Non-operating: -30°C to 60°C (-22°F to 140°F)
- Extended operating temperature with limited configuration options: -5° to 55°C (23° to 131°F)

The approved hardware configurations for this system are listed in the [Extended Ambient Temperature Guidelines for Gen11 HPE ProLiant servers](#):

<https://www.hpe.com/support/ASHRAEGen11>

Power requirements

Installation of this equipment must comply with local and regional electrical regulations governing the installation of information technology equipment by licensed electricians. This equipment is designed to operate in installations covered by NFPA 70, 1999 Edition (National Electric Code) and NFPA-75, 1992 (code for Protection of Electronic Computer/Data Processing Equipment). For electrical power ratings on options, refer to the product rating label or the user documentation supplied with that option.



WARNING

To reduce the risk of personal injury, fire, or damage to the equipment, do not overload the AC supply branch circuit that provides power to the rack. Consult the electrical authority having jurisdiction over wiring and installation requirements of your facility.



CAUTION

Protect the server from power fluctuations and temporary interruptions with a regulating uninterruptible power supply. This device protects the hardware from damage caused by power surges and voltage spikes and keeps the system in operation during a power failure.

Electrical grounding requirements

The server must be grounded properly for proper operation and safety. In the United States, you must install the equipment in accordance with NFPA 70, National Electric Code Article 250, as well as any local and regional building codes. In Canada, you must install the equipment in accordance with Canadian Standards Association, CSA C22.1, Canadian Electrical Code. In all other countries, you must install the equipment in accordance with any regional or national electrical wiring codes, such as the International Electrotechnical Commission (IEC) Code 364, parts 1 through 7. Furthermore, you must be sure that all power distribution devices used in the installation, such as branch wiring and receptacles, are listed or certified grounding-type devices.

Because of the high ground-leakage currents associated with multiple servers connected to the same power source, Hewlett Packard Enterprise recommends the use of a PDU that is either permanently wired to the building's branch circuit or includes a nondetachable cord that is wired to an industrial-style plug. NEMA locking-style plugs or those complying with IEC 60309 are considered suitable for this purpose. Using common power outlet strips for the server is not recommended.

Rack warnings and cautions



WARNING

When all components are removed, the server weighs 11.38 kg (25.09 lb). When all components are installed, the server can weigh up to 15.18 kg (33.47 lb).

Before configuring your rack solution, be sure to check the rack manufacturer weight limits and specifications. Failure to do so can result in physical injury or damage to the equipment and the facility.



WARNING

The server is heavy. To reduce the risk of personal injury or damage to the equipment, do the following:

- Observe local occupational health and safety requirements and guidelines for manual material handling.
- Get help to lift and stabilize the product during installation or removal, especially when the product is not fastened to the rails. The server weighs more than 11.38 kg (25.09 lb), so at least two people must lift the server into the rack together. An additional person may be required to help align the server if the server is installed higher than chest level.
- Use caution when installing the server in or removing the server from the rack.
- Adequately stabilize the rack before extending a component outside the rack. Extend only one component at a time. A rack may become unstable if more than one component is extended.
- Do not stack anything on top of rail-mounted component or use it as a work surface when extended from the rack.



WARNING

To reduce the risk of personal injury or damage to the equipment, be sure that:

- The rack has anti-tip measures in place. Such measures include floor-bolting, anti-tip feet, ballast, or a combination as specified by the rack manufacturer and applicable codes.
- The leveling jacks (feet) are extended to the floor.
- The full weight of the rack rests on the leveling jacks (feet).
- The stabilizing feet are attached to the rack if it is a single-rack installation.
- The racks are coupled together in multiple rack installations.



WARNING

To reduce the risk of personal injury or equipment damage when unloading a rack:

- At least two people are needed to safely unload the rack from the pallet. An empty 42U rack can weigh as much as 115 kg (253 lb), can stand more than 2.1 m (7 ft) tall, and might become unstable when being moved on its casters.
- Never stand in front of the rack when it is rolling down the ramp from the pallet. Always handle the rack from both sides.



**CAUTION**

Always plan the rack installation so that the heaviest item is on the bottom of the rack. Install the heaviest item first, and continue to populate the rack from the bottom to the top.

**CAUTION**

Before installing the server in a rack, be sure to properly scope the limitations of the rack. Before proceeding with the installation, consider the following:

- You must fully understand the static and dynamic load carrying capacity of the rack and be sure that it can accommodate the weight of the server.
- Be sure sufficient clearance exists for cabling, installation and removal of the server, and movement of the rack doors.

Server warnings and cautions

**WARNING**

To reduce the risk of personal injury, electric shock, or damage to the equipment, disconnect the power cord to remove power from the server. Pressing the Power On/Standby button does not shut off system power completely. Portions of the power supply and some internal circuitry remain active until AC power is removed.

**WARNING**

To reduce the risk of personal injury from hot surfaces, allow the drives and the internal system components to cool before touching them.

**WARNING**

To reduce the risk of fire or burns after removing the energy pack:

- Do not disassemble, crush, or puncture the energy pack.
- Do not short external contacts.
- Do not dispose of the energy pack in fire or water.
- Do not expose the energy pack to low air pressure as it might lead to explosion or leakage of flammable liquid or gas.
- Do not expose the energy pack to temperatures higher than 60°C (140°F).

After power is disconnected, battery voltage might still be present for 1s to 160s.

**CAUTION**

Protect the server from power fluctuations and temporary interruptions with a regulating UPS. This device protects the hardware from damage caused by power surges and voltage spikes and keeps the server in operation during a power failure.

**CAUTION**

To prevent damage to electrical components, properly ground the server before beginning any installation, removal, or replacement procedure. Improper grounding can cause electrostatic discharge.





CAUTION

To avoid data loss, Hewlett Packard Enterprise recommends that you back up all server data before installing or removing a hardware option, or performing a server maintenance or troubleshooting procedure.



CAUTION

Do not operate the server for long periods with the access panel open or removed. Operating the server in this manner results in improper airflow and improper cooling that can lead to thermal damage.

Electrostatic discharge

Be aware of the precautions you must follow when setting up the system or handling components. A discharge of static electricity from a finger or other conductor may damage system boards or other static-sensitive devices. This type of damage may reduce the life expectancy of the system or component.

To prevent electrostatic damage:

- Avoid hand contact by transporting and storing products in static-safe containers.
- Keep electrostatic-sensitive parts in their containers until they arrive at static-free workstations.
- Place parts on a grounded surface before removing them from their containers.
- Avoid touching pins, leads, or circuitry.
- Always be properly grounded when touching a static-sensitive component or assembly. Use one or more of the following methods when handling or installing electrostatic-sensitive parts:
 - Use a wrist strap connected by a ground cord to a grounded workstation or computer chassis. Wrist straps are flexible straps with a minimum of 1 megohm \pm 10 percent resistance in the ground cords. To provide proper ground, wear the strap snug against the skin.
 - Use heel straps, toe straps, or boot straps at standing workstations. Wear the straps on both feet when standing on conductive floors or dissipating floor mats.
 - Use conductive field service tools.
 - Use a portable field service kit with a folding static-dissipating work mat.

If you do not have any of the suggested equipment for proper grounding, have an authorized reseller install the part.

For more information on static electricity or assistance with product installation, contact an authorized reseller.

Operations

This chapter describes the hardware operations carried out prior to and after installing or removing a hardware component, or performing a server maintenance or troubleshooting procedure. Before performing these hardware operations, review the:

- [Rack warnings and cautions](#)
- [Server warnings and cautions](#)

Subtopics

[Remove the front bezel](#)

[Power down the server](#)

[Open the cable management arm](#)



Extend the server out of the rack

Remove the server from a four-post rack

Remove the server from a two-post rack

Remove the access panel

Remove the air baffle

Remove the three-slot riser cage

Remove the drive base cage with the SFF/E3.S drive cage installed

Install the drive base cage with the SFF/E3.S drive cage installed

Install the three-slot riser cage

Install the air baffle

Install the access panel

Power up the server

Remove the front bezel

Prerequisites

The server has the FIO front bezel and its brackets (option kit: P72582-B21) installed.

About this task

If you are using the iLO virtual power button to power the server on/off, you do not need to remove the front bezel.

Procedure

1. If installed, remove the Kensington security lock.

For more information, see the lock documentation.

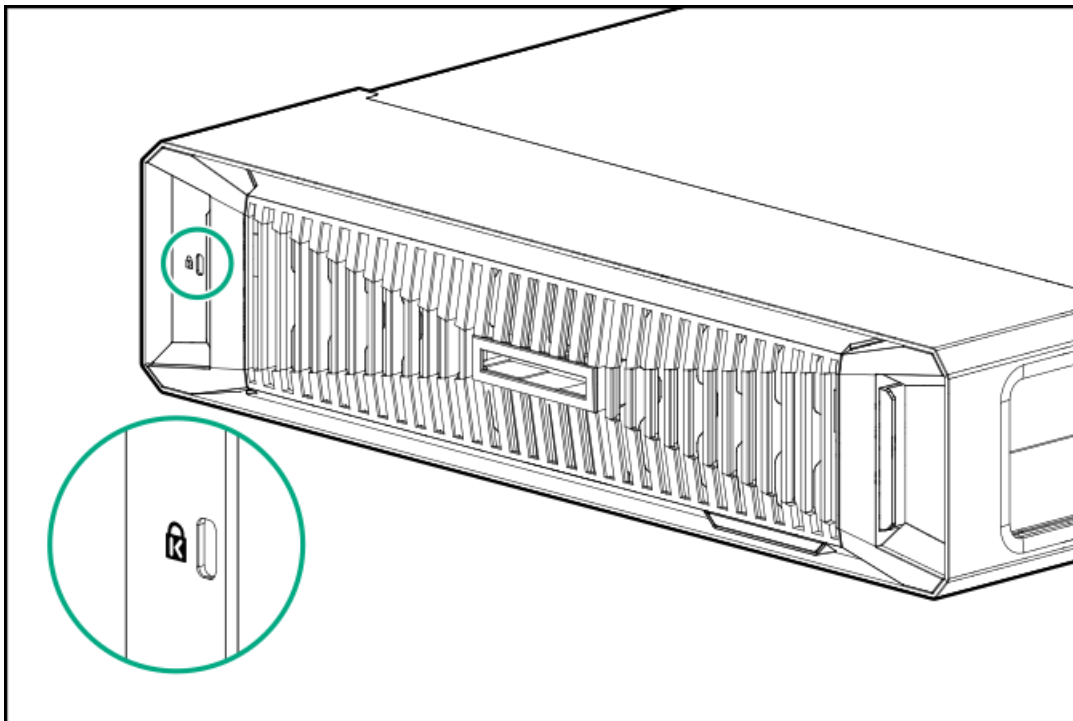

2. Press and hold the bezel release latches, and then slide out the bezel.

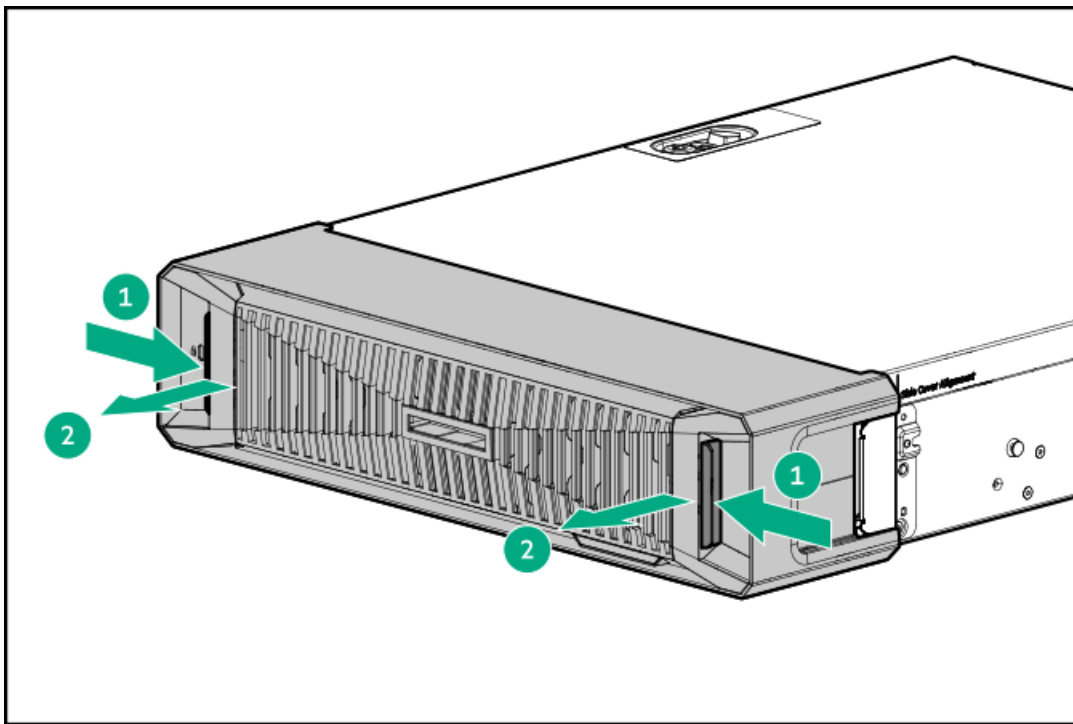

Power down the server

Before powering down the server for any upgrade or maintenance procedures, perform a backup of critical server data and programs.



IMPORTANT

When the server is in standby mode, auxiliary power is still being provided to the system.

To power down the server, use one of the following methods:

- Press and release the Power On/Standby button.
This method activates a controlled shutdown of applications and the OS before the server enters standby mode. It can also activate a shutdown behavior governed by an OS configuration or policy.
- Press and hold the Power On/Standby button for more than 4 seconds to force the server to enter standby mode.
This method forces the server to enter standby mode without properly exiting applications and the OS. If an application stops responding, you can use this method to force a shutdown.
- Use a virtual power button selection through iLO 6.
This method initiates a controlled remote shutdown of applications and the OS before the server enters standby mode.

Before proceeding, verify that the server is in standby mode by observing that the system power LED is amber.

Open the cable management arm

Procedure

1. Press and hold the blue **PUSH** button on the retention bracket.
2. Swing the arm away from the rear panel.



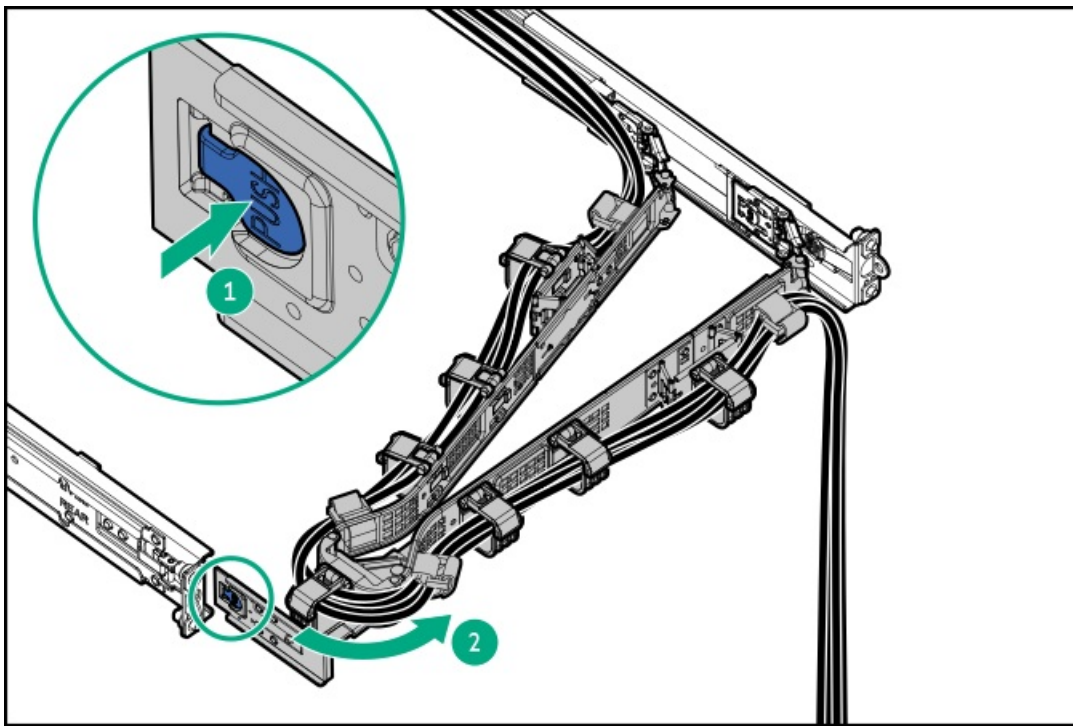

Extend the server out of the rack

Prerequisites

- Before you perform this procedure, review the [Rack warnings and cautions](#).
- T-25 Torx screwdriver—This tool is required if the shipping screws located on the optional rack mount brackets are secured. For more information, see [Rack enablement option](#).

About this task



WARNING

To reduce the risk of personal injury, be careful when pressing the server rail-release latches. The inner rails could pinch your fingers.

Procedure

1. If needed, loosen the shipping screws, and then use the rack mount brackets to slide the server out of the rack until the rail-release latches are engaged.

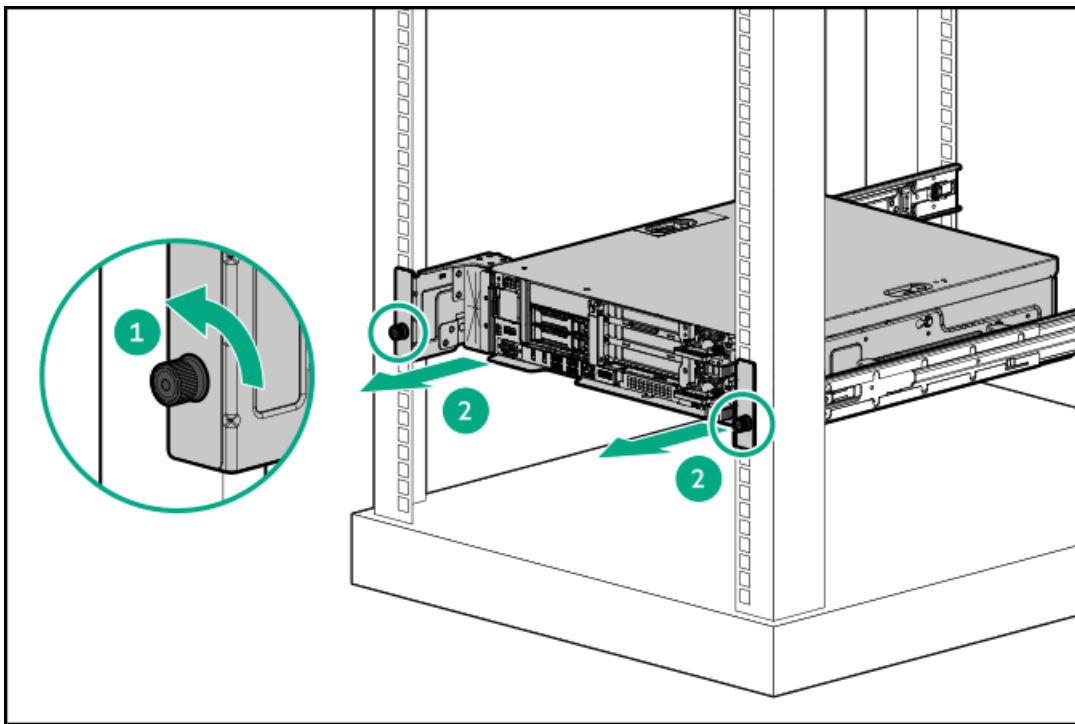

2. Press and hold the rear-end rail-release latches, and then slide the server out of the rack until it is fully extended.



WARNING

To reduce the risk of personal injury, be careful when pressing the server rail-release latches. The inner rails could pinch your fingers.

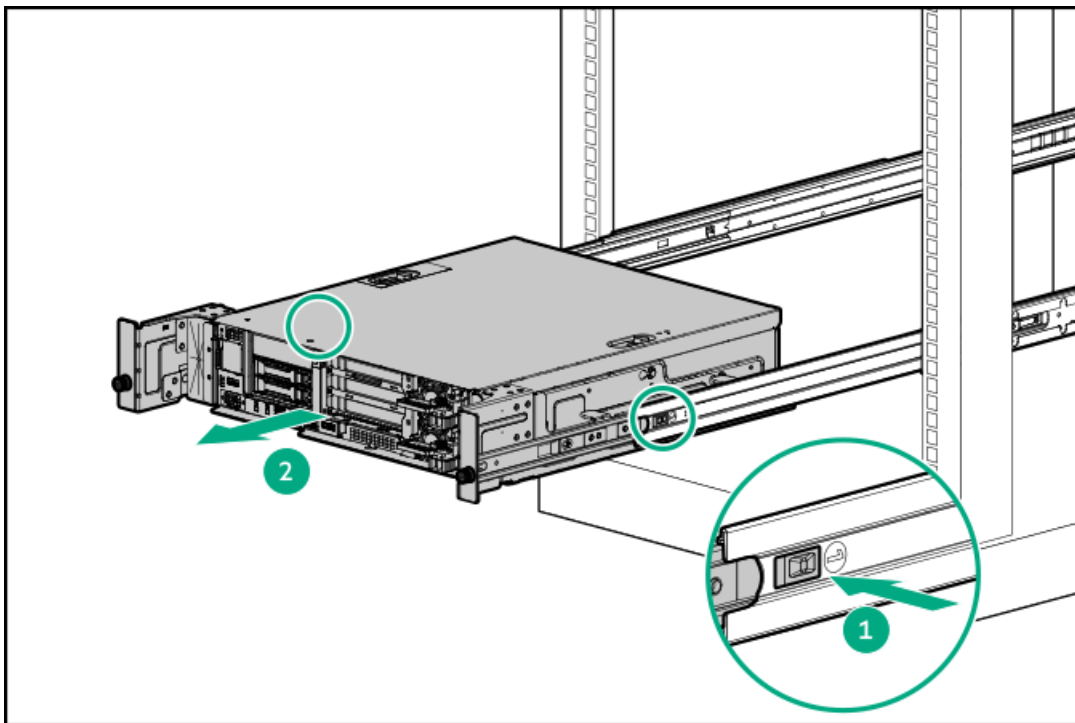

Remove the server from a four-post rack

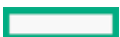

Prerequisites

-  **IMPORTANT**
Get help to lift and stabilize the server during removal from the rack. **If the server is installed higher than chest level, additional two people might be required to help remove the server:** One person to support the server weight, and the other two to slide the server out of the rack.
- Before you perform this procedure, review the:
 - [Rack warnings and cautions](#)
 - [Server warnings and cautions](#)
- A fully populated server is heavy. Hewlett Packard Enterprise recommends removing the external chassis components before removing the server from the rack.

About this task

Procedure

1. If installed, [remove the front bezel](#).
2. [Power down the server](#).
3. If installed, [open the cable management arm](#).
4. Remove all power:
 - a. Disconnect each power cord from the power source.
 - b. Disconnect each power cord from the server.
5. Disconnect all peripheral cables from the server.



WARNING

To reduce the risk of personal injury or equipment damage, be sure that the rack is adequately stabilized before extending a component from the rack.

6. Release the peripheral cables and power cords from the rack mount brackets.

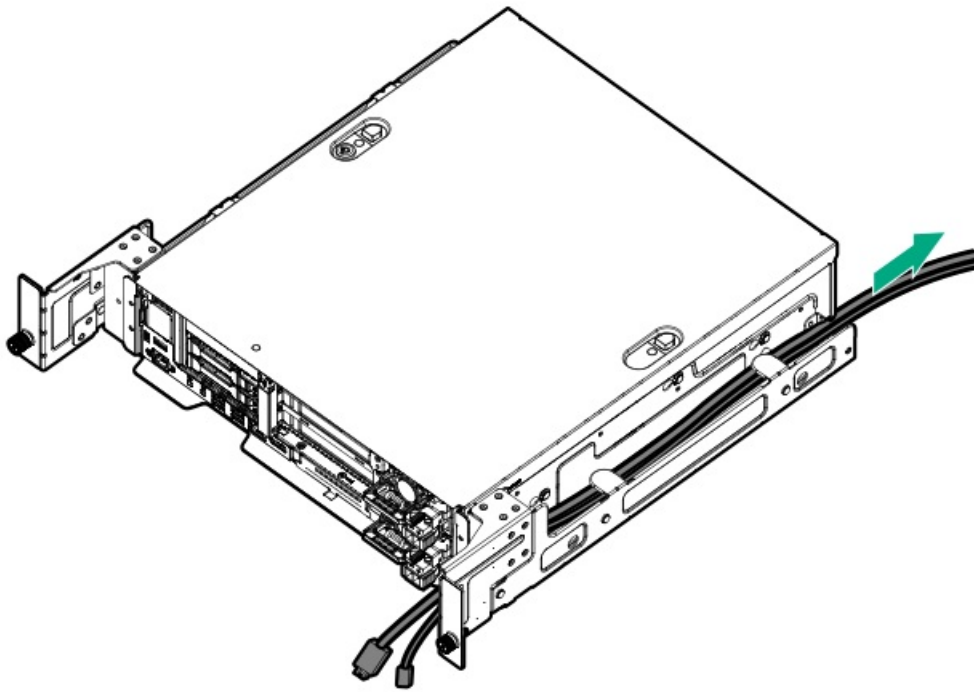

7. Extend the server from the rack.

8.  **WARNING**

To reduce the risk of personal injury, be careful when pressing the server rail-release latches. The inner rails could pinch your fingers.

Remove the server from the rack:

- a. Press and hold the protruding surface of the sliding rails.
- b. Remove the server from the rack.

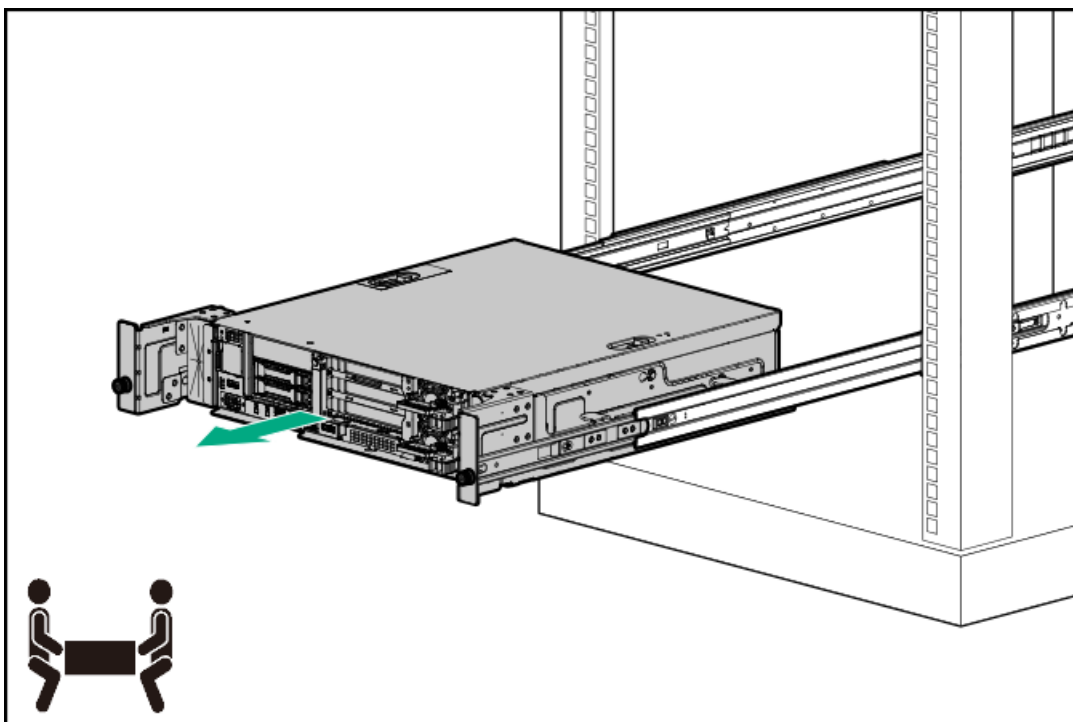

9. Place the server on a flat, level work surface.



Remove the server from a two-post rack

Prerequisites

-  **IMPORTANT**
Get help to lift and stabilize the server during removal from the rack. **If the server is installed higher than chest level, additional two people might be required to help remove the server:** One person to support the server weight, and the other two to slide the server out of the rack.
- Before you perform this procedure, review the:
 - [Rack warnings and cautions](#)
 - [Server warnings and cautions](#)
- A fully populated server is heavy. Hewlett Packard Enterprise recommends removing the external chassis components before removing the server from the rack.

Procedure

1. If installed, [remove the front bezel](#).
 2. [Power down the server](#).
 3. If installed, [release the cable management arm](#).
 4. Remove all power:
 - a. Disconnect each power cord from the power source.
 - b. Disconnect each power cord from the server.
 5. Disconnect all peripheral cables from the server.
-  **WARNING**
To reduce the risk of personal injury or equipment damage, be sure that the rack is adequately stabilized before extending a component from the rack.
6. Release the peripheral cables and power cords from the rack mount brackets.

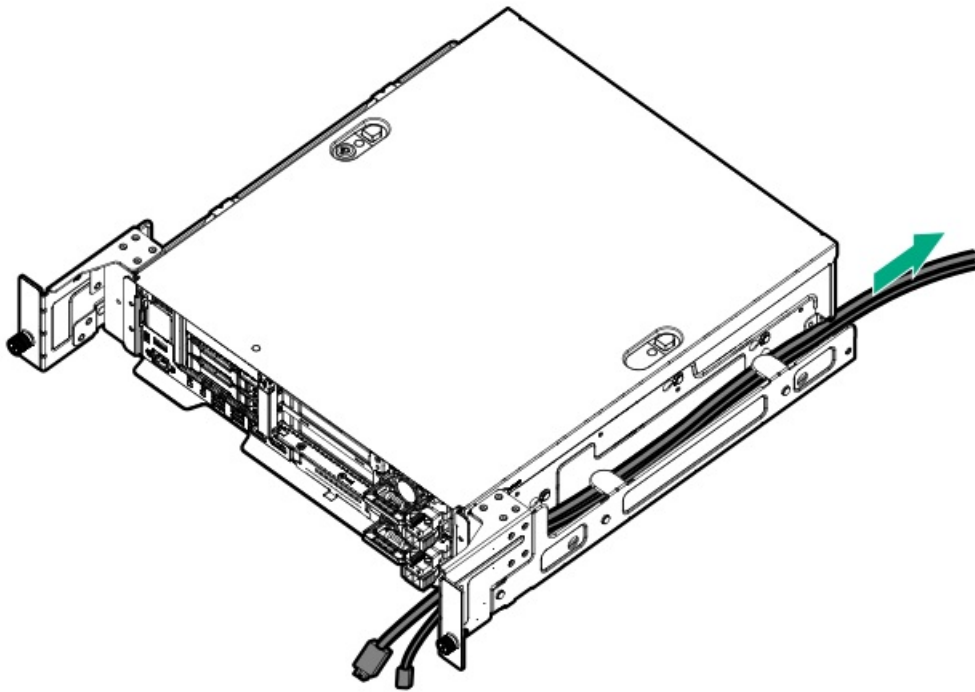

7. If needed, loosen the ear screws of the rack mount brackets, and then use the rack mount brackets to slide the server out of the rack.

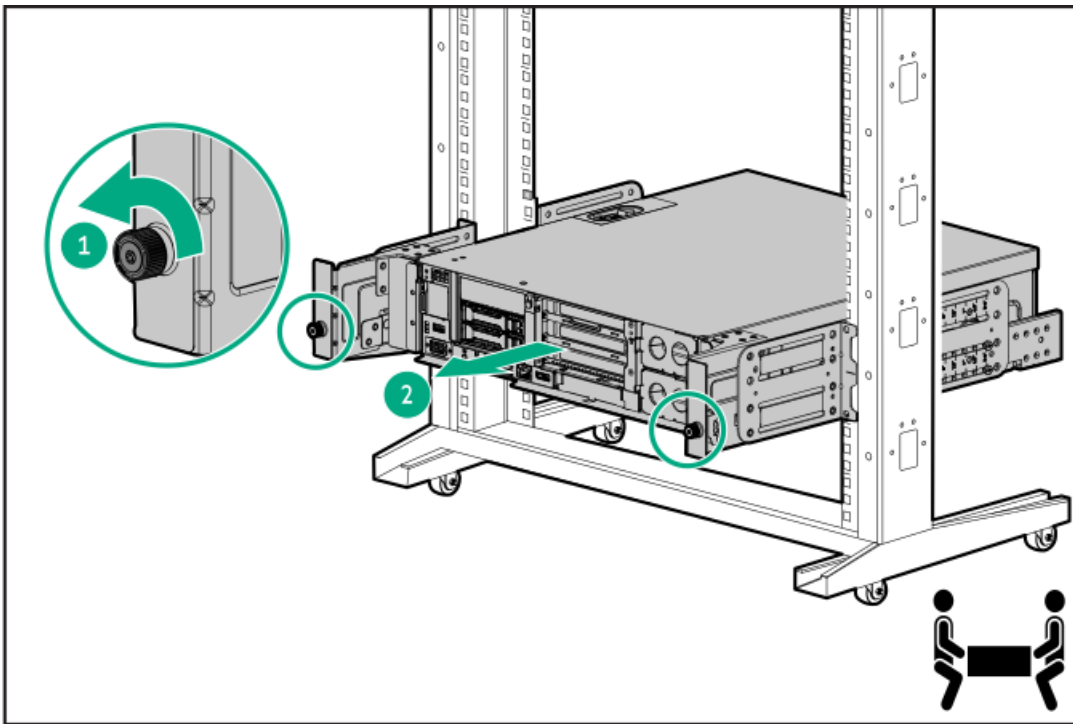

8. Remove the server from the two-post rack support brackets.



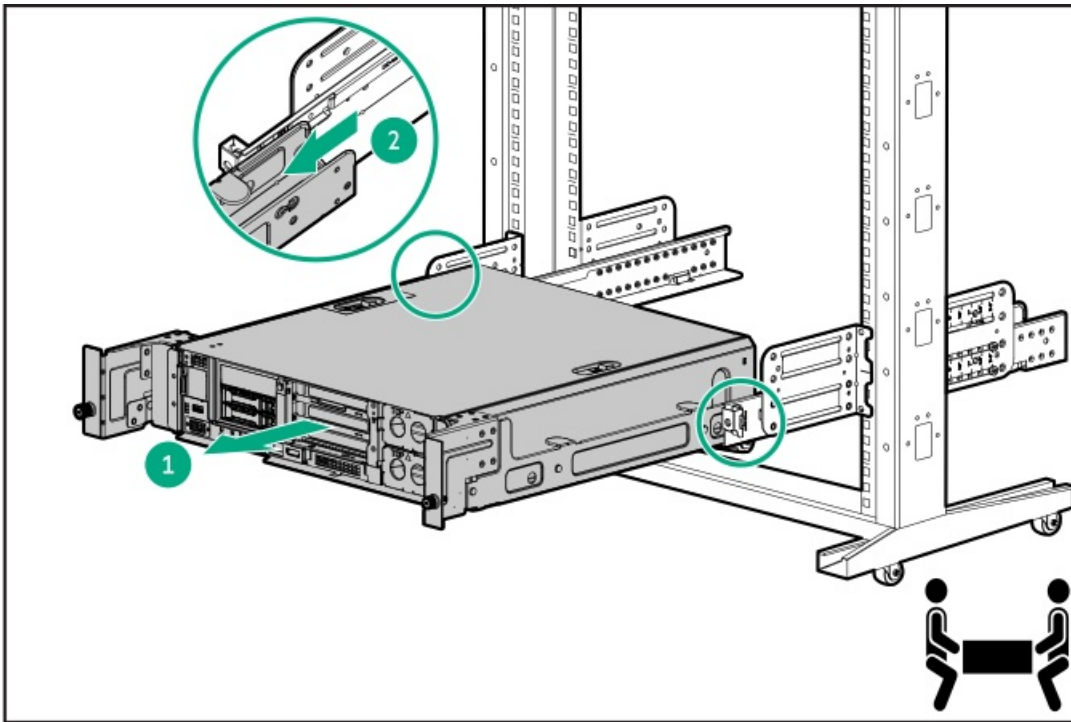

9. Place the server on a flat, level work surface.

Remove the access panel

About this task



WARNING

To reduce the risk of personal injury from hot surfaces, allow the drives and the internal system components to cool before touching them.



CAUTION

To prevent damage to electrical components, properly ground the server before beginning any installation, removal, or replacement procedure. Improper grounding can cause electrostatic discharge.



CAUTION

To maintain proper system cooling, do not operate the server for long period with the access panel open or removed. Operating the server in this manner results in an improper system airflow. For internal hot-plug component procedures, complete the procedure within 60 seconds. Failure to do so can cause the system temperature to increase and trip the safety threshold. When this happens:

- The health LED flashes amber.
- The operating system gracefully shuts down.

Procedure

1. If installed, remove the front bezel.
2. Power down the server.
3. Remove all power:

- a. Disconnect each power cord from the power source.
 - b. Disconnect each power cord from the server.
4. Disconnect all peripheral cables from the server.
5. Remove the server from the rack:
- [Remove the server from a four-post rack.](#)
 - [Remove the server from a two-post rack.](#)
6. Place the server on a flat, level work surface.
7. Remove the access panel:
- a. If needed, unlock the access panel.
 - b. To disengage the access panel from the chassis, press and hold the two release buttons and slide the access panel to the rear of the chassis.
 - c. Lift the access panel.

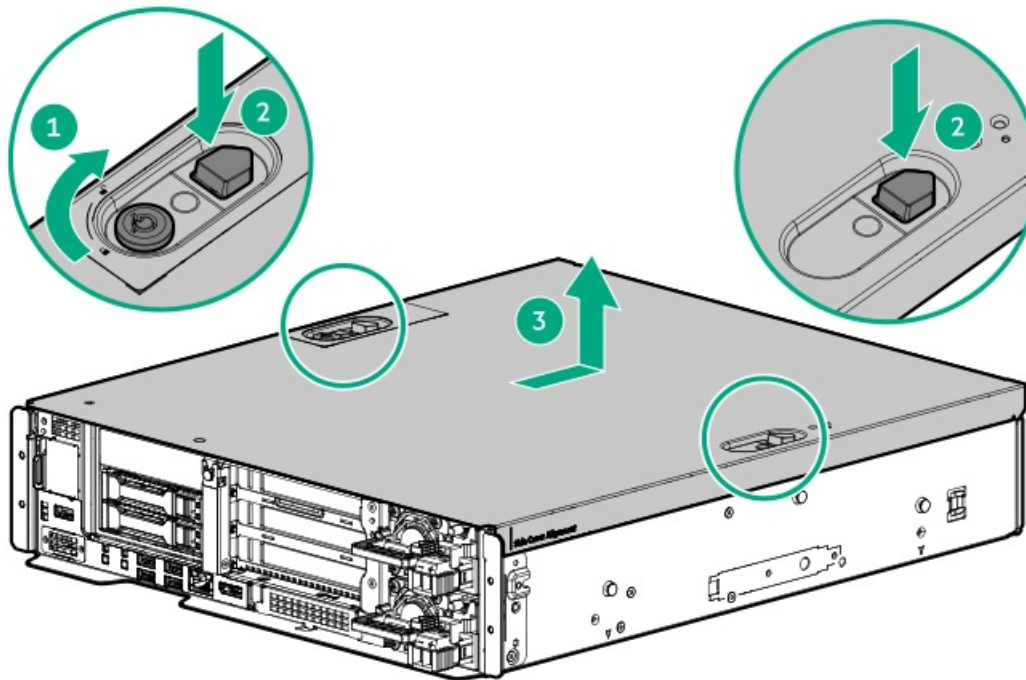

Remove the air baffle

About this task



CAUTION

For proper cooling, do not operate the server without the access panel, baffles, expansion slot covers, or blanks installed. If the server supports hot-plug components, minimize the amount of time the access panel is open.

Procedure

1. If installed, [remove the front bezel.](#)



2. Power down the server.
3. Remove all power:
 - a. Disconnect each power cord from the power source.
 - b. Disconnect each power cord from the server.
4. Disconnect all peripheral cables from the server.
5. Remove the server from the rack.
6. Place the server on a flat, level work surface.
7. Remove the access panel.
8. Use the blue finger hooks to lift the air baffle away from the chassis.

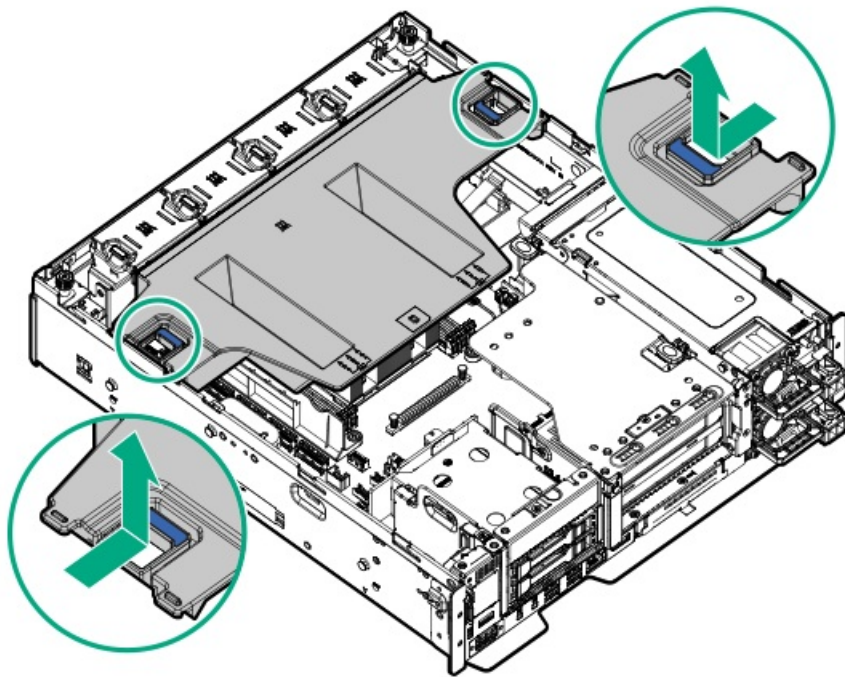

Remove the three-slot riser cage

About this task



WARNING

To reduce the risk of personal injury from hot surfaces, allow the drives and the internal system components to cool before touching them.



CAUTION

A discharge of static electricity from a finger or other conductor might damage system boards or other static-sensitive devices. To prevent damage, observe antistatic precautions.

Procedure

1. If installed, remove the front bezel.
2. Power down the server.

3. Remove all power:
 - a. Disconnect each power cord from the power source.
 - b. Disconnect each power cord from the server.
4. Disconnect all peripheral cables from the server.
5. Remove the server from the rack.
6. Place the server on a flat, level work surface.
7. Remove the access panel.
8. Remove the air baffle.
9. If an expansion card with internal cables is installed on the riser, disconnect the cables from the card.
10. If stacking risers are installed in PCIe slot 1-2, disconnect the stacking riser cables from the system board.
11. Remove the three-slot riser cage:
 - a. Release the half-turn spring latches.
 - b. Use the blue touchpoints on both sides to lift the riser cage off the system board.

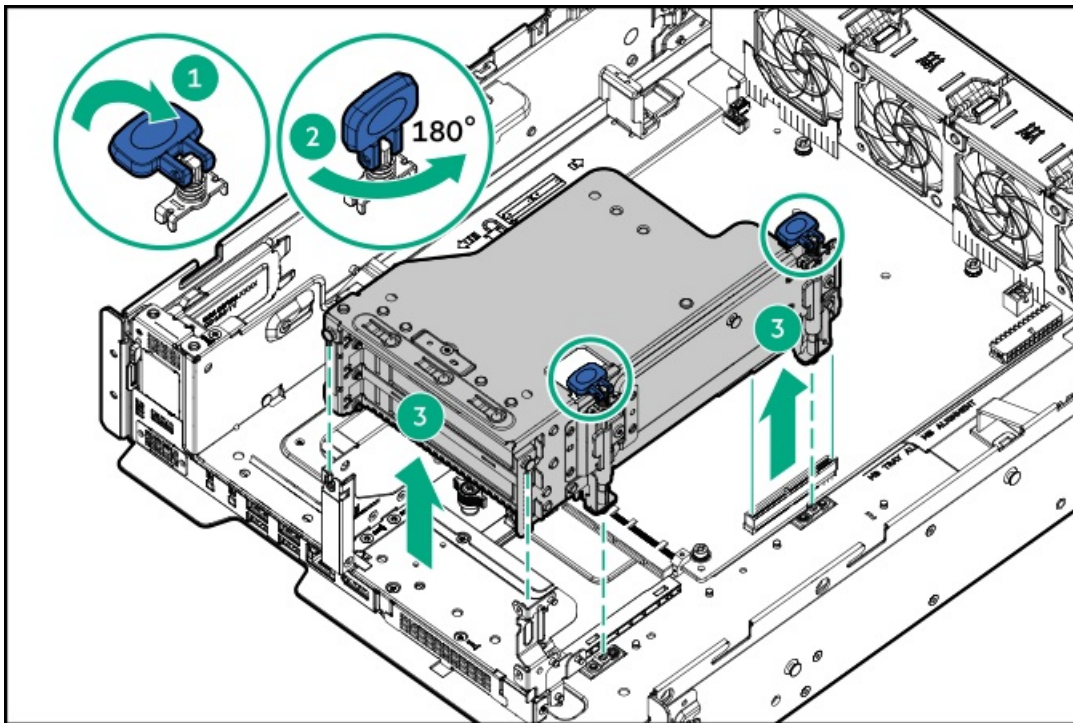

Remove the drive base cage with the SFF/E3.S drive cage installed

Prerequisites

Before you perform this procedure, make sure that you have the following items available:

- T-10 Torx screwdriver
- Small slotted screwdriver—This tool is required only if the E3.S drive cage fillers are to be removed.

About this task





CAUTION

A discharge of static electricity from a finger or other conductor might damage system boards or other static-sensitive devices. To prevent damage, observe [antistatic precautions](#).



CAUTION

To prevent improper cooling and thermal damage, do not operate the server unless all bays are populated with either a component or a blank.

Procedure

1. If installed, [remove the front bezel](#).
2. [Power down the server](#).
3. Remove all power:
 - a. Disconnect each power cord from the power source.
 - b. Disconnect each power cord from the server.
4. Disconnect all peripheral cables from the server.
5. [Remove the server from the rack](#).
6. Place the server on a flat, level work surface.
7. [Remove the access panel](#).
8. [Remove the air baffle](#).
9. If installed, remove the bezel brackets.

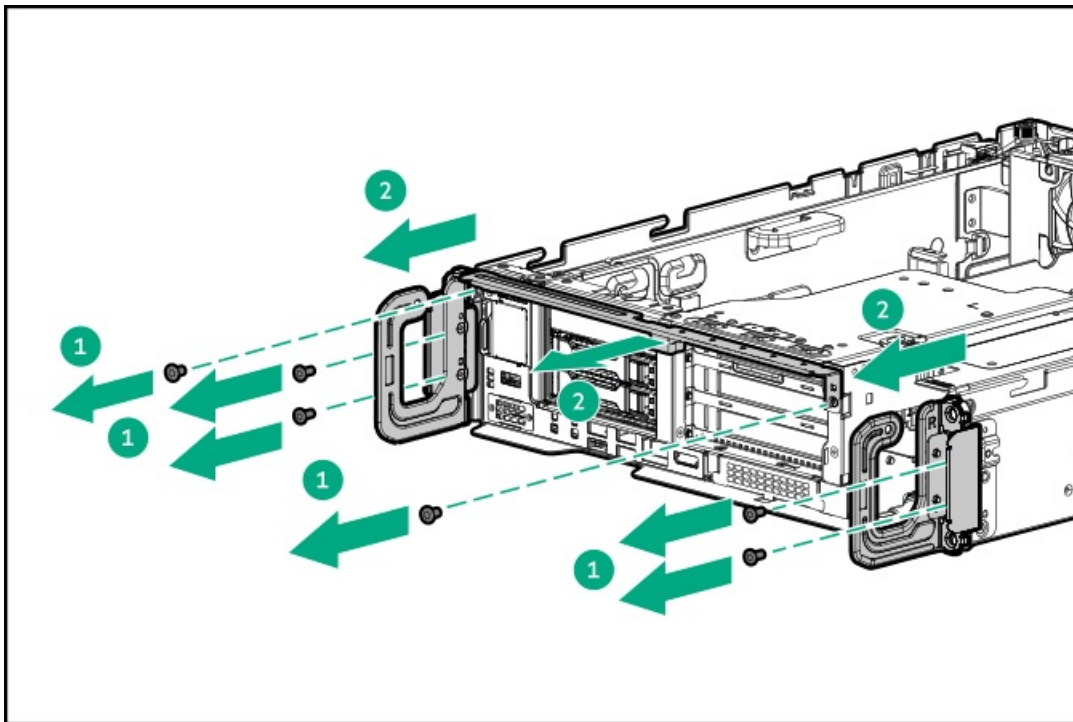

10. [Remove the three-slot riser cage](#).
11. Disconnect the [drive power and signal cables](#) from the drive backplane.
12. Remove the drive base cage:
 - a. Remove the drive base cage screws.



b. Slide the cage toward the front panel, and then lift it out of the chassis.

- SFF drive configuration

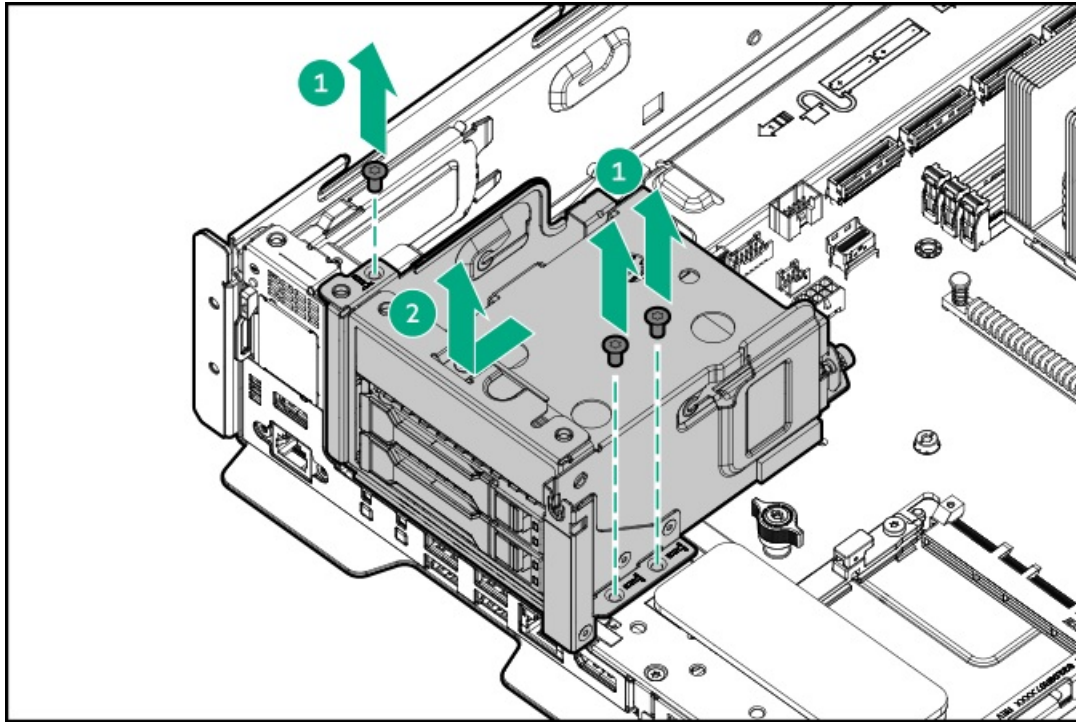

- E3.S drive configuration

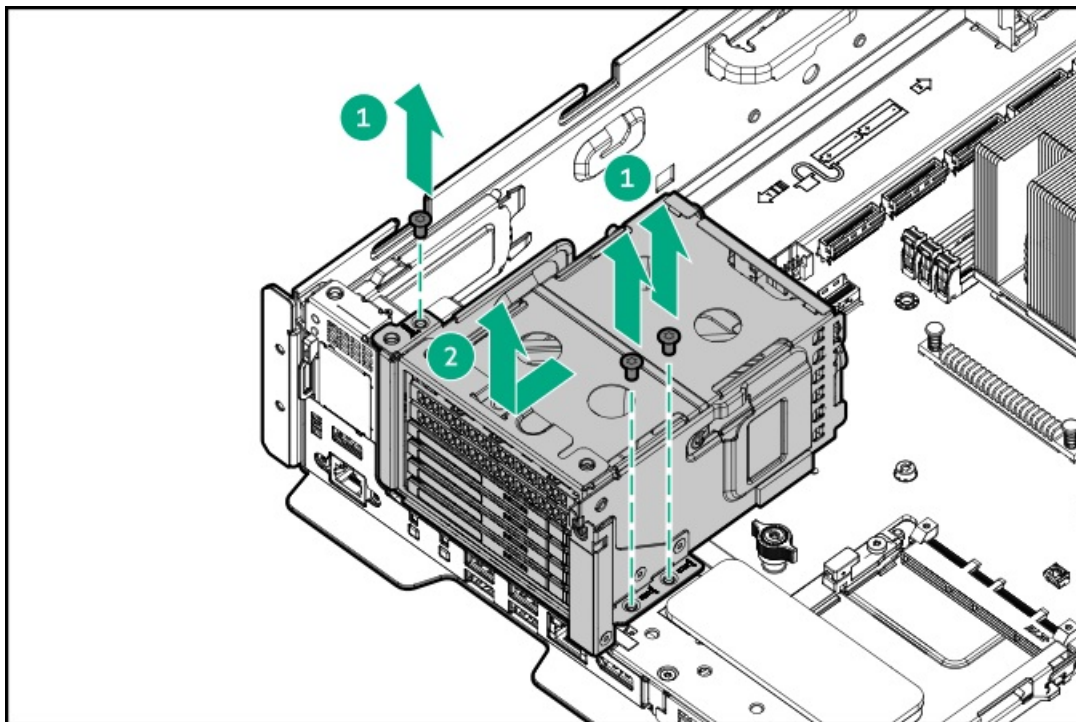

13. Remove all drives.

- SFF drive



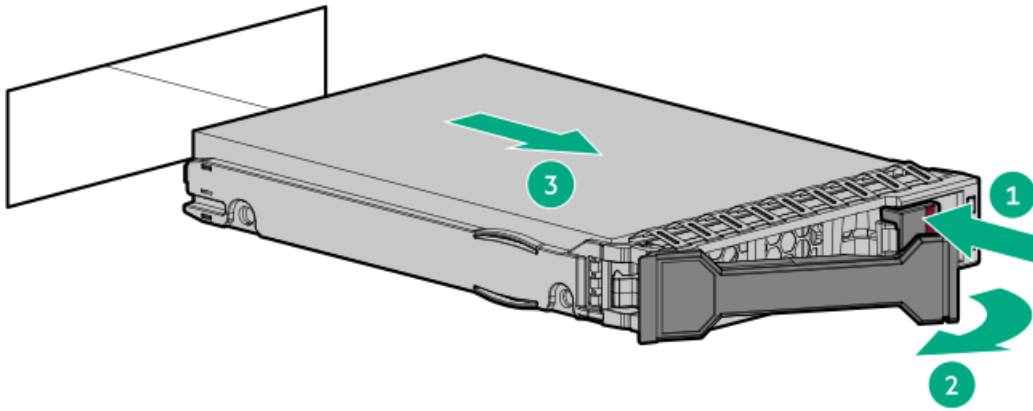

- E3.S drive

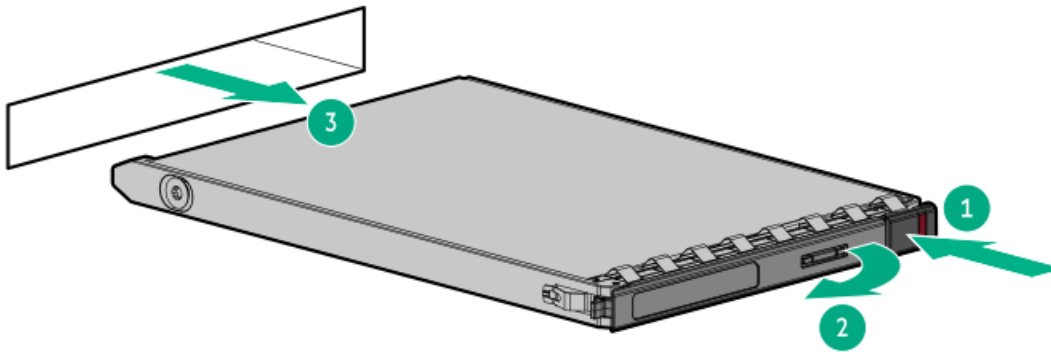

- E3.S drive cage filler for the 4 E3.S drive configuration.

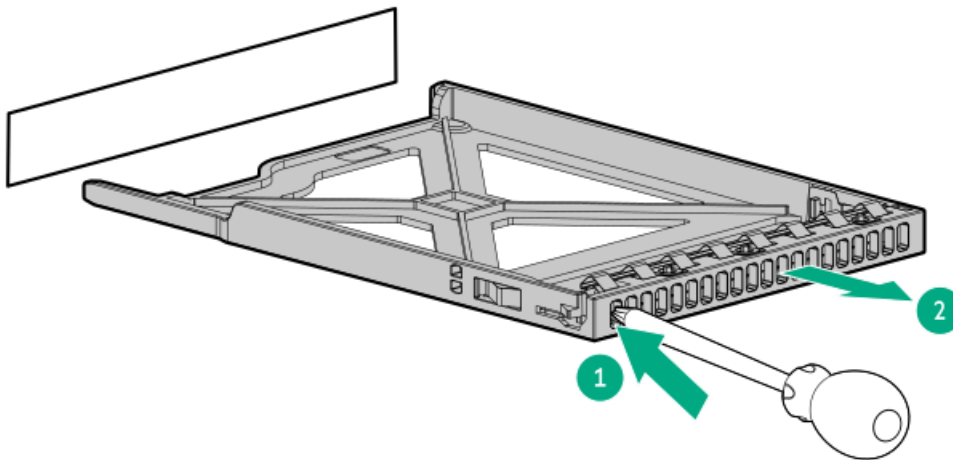

Install the drive base cage with the SFF/E3.S drive cage installed

Prerequisites

Before you perform this procedure, make sure that you have a T-10 Torx screwdriver available.

About this task



**CAUTION**

A discharge of static electricity from a finger or other conductor might damage system boards or other static-sensitive devices. To prevent damage, observe antistatic precautions.

**CAUTION**

To prevent improper cooling and thermal damage, do not operate the server unless all bays are populated with either a component or a blank.

Procedure**1. Install all drives or drive blanks.**

- SFF drive

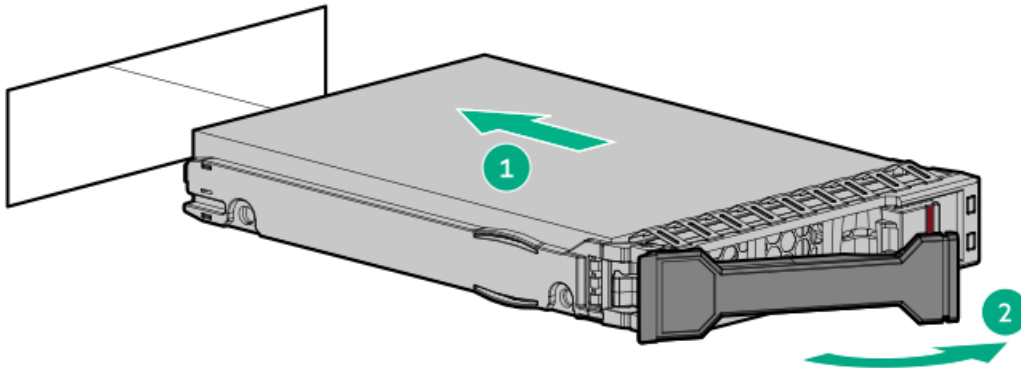

- E3.S drive

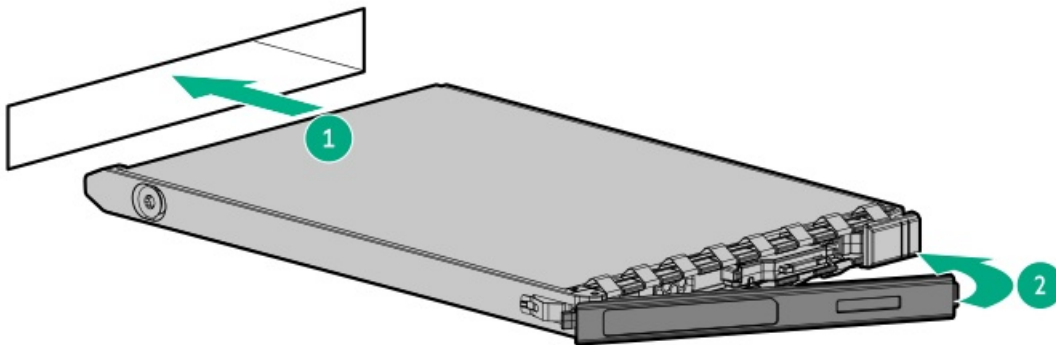
**2. Install the drive base cage:**

- a. Position the drive base cage on the chassis, and then slide it toward the rear panel to engage with the spool on the chassis.
 - b. Install the screws.
- SFF drive configuration



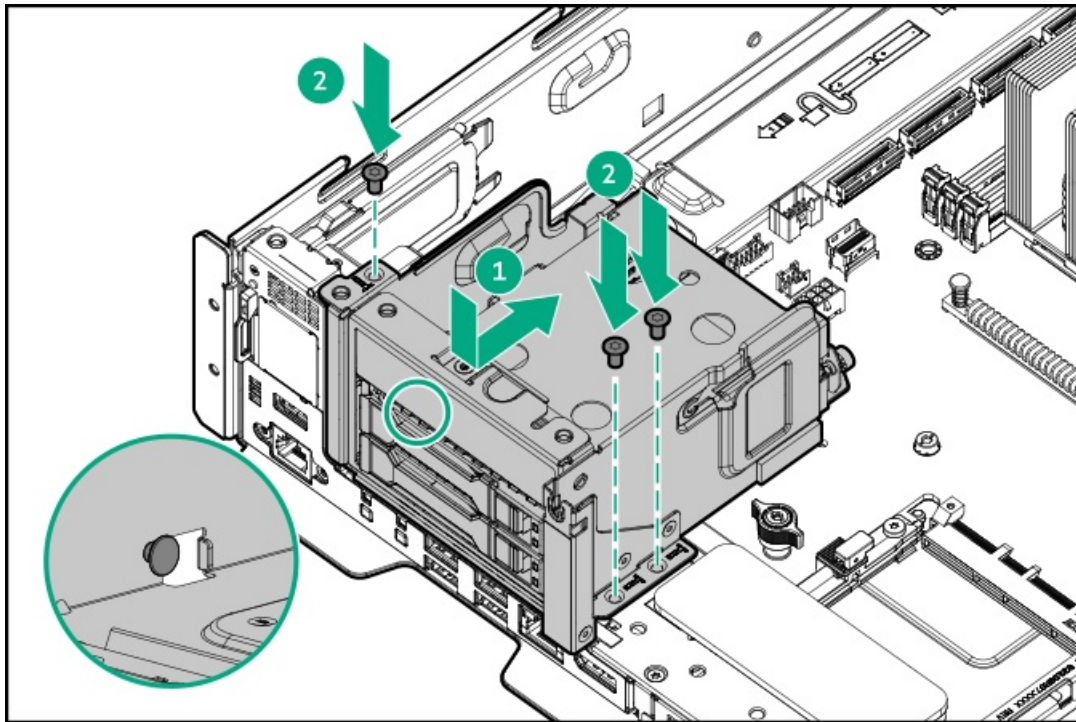

- E3.S drive configuration

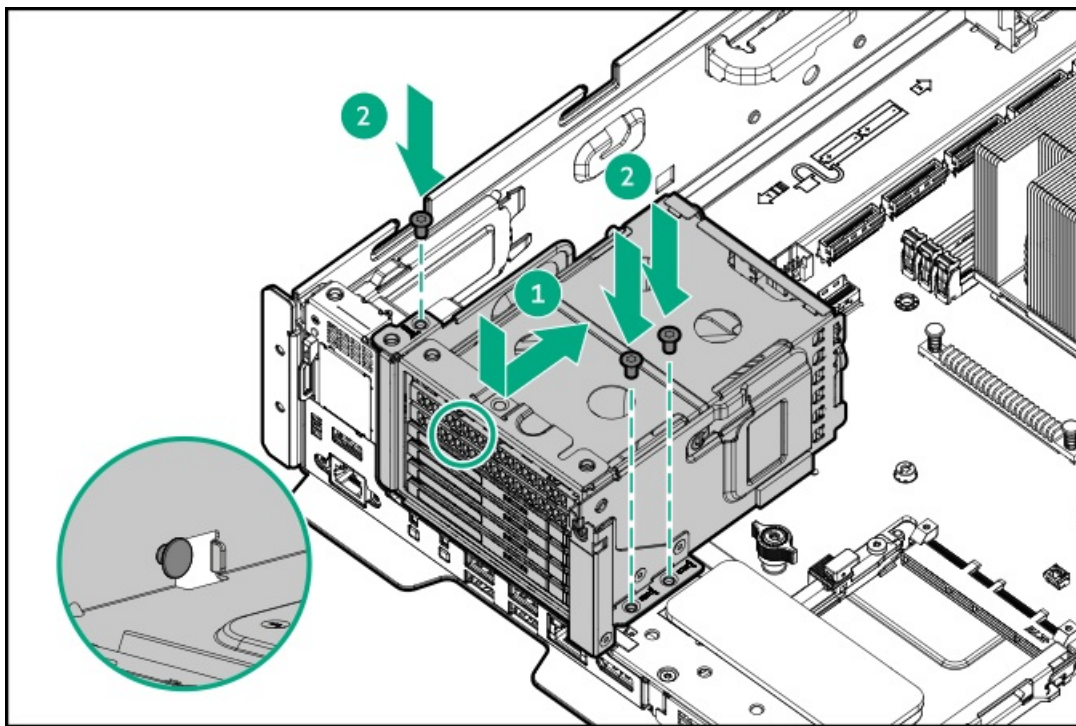

3. Connect the drive power and signal cables to the SFF/E3.S drive backplane.
4. Perform the post-installation or maintenance steps required by the procedure that necessitates the removal of the drive base cage.

Install the three-slot riser cage

About this task





CAUTION

A discharge of static electricity from a finger or other conductor might damage system boards or other static-sensitive devices. To prevent damage, observe antistatic precautions.

Procedure

1. If an expansion card or its internal cabling was removed, reinstall the component.
2. Install the three-slot riser cage:
 - a. Carefully press the riser down on its system board connector.

Make sure that:

- The riser cage is aligned with the front chassis.
 - The riser board is firmly seated on the system board.
- b. Simultaneously push and rotate the half-turn spring latches to 180°.
 - c. Close the spring latches.

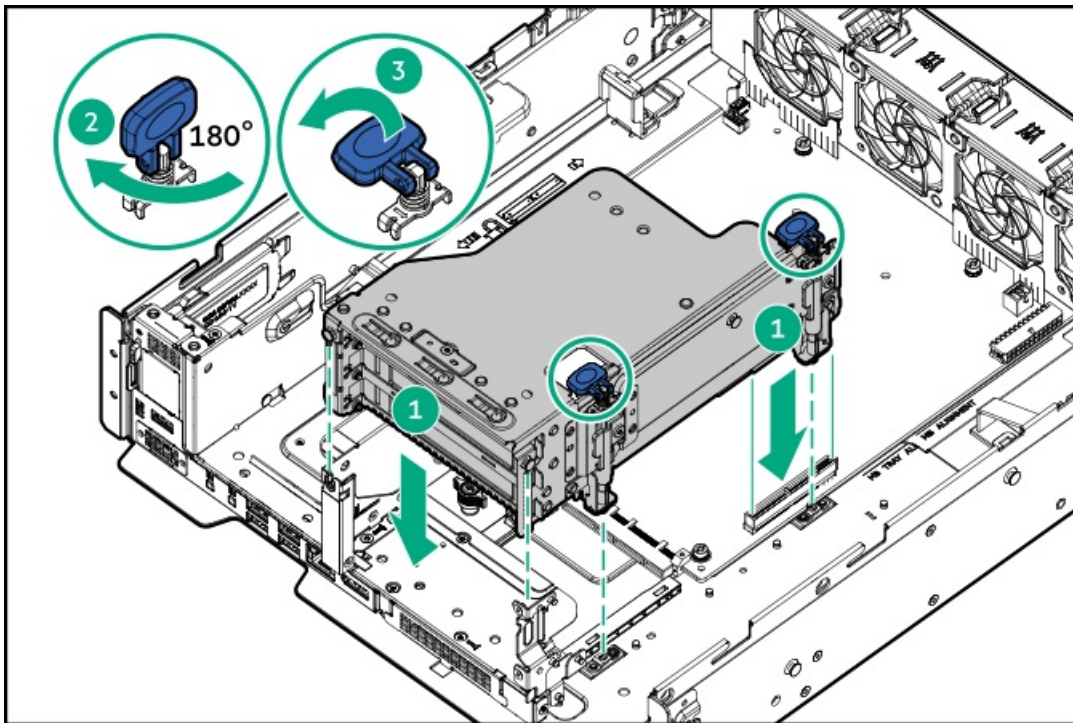

3. Perform the post-installation or maintenance steps required by the procedure that necessitates the removal of the riser cage.

Install the air baffle

Procedure

1. Make sure that all internal cables have been properly routed and will not interfere with the air baffle installation.
2. Lower the air baffle into the chassis and make sure that it fits properly into place.



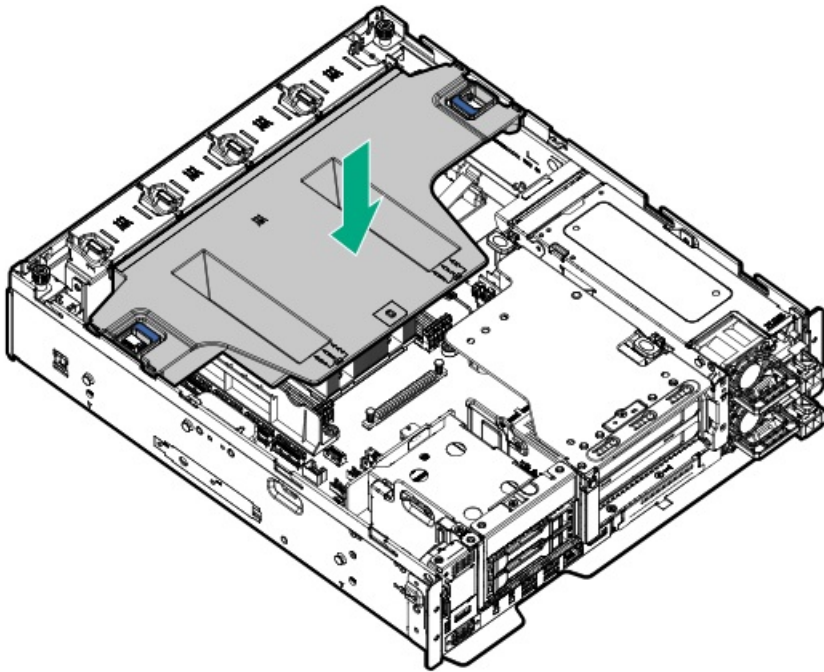

3. [Install the access panel.](#)
4. Perform the post-installation or maintenance steps required by the procedure that necessitates the removal of the air baffle.

Install the access panel

Procedure

1. Install the access panel:
 - a. With the access panel lock in the open position, align the front edge of the access panel to the guides on the chassis, and then place the access panel on top of the server.
 - b. Slide the access panel to the front of the chassis.
A click sound indicates the access panel is properly engaged.
 - c. If needed, lock the access panel.

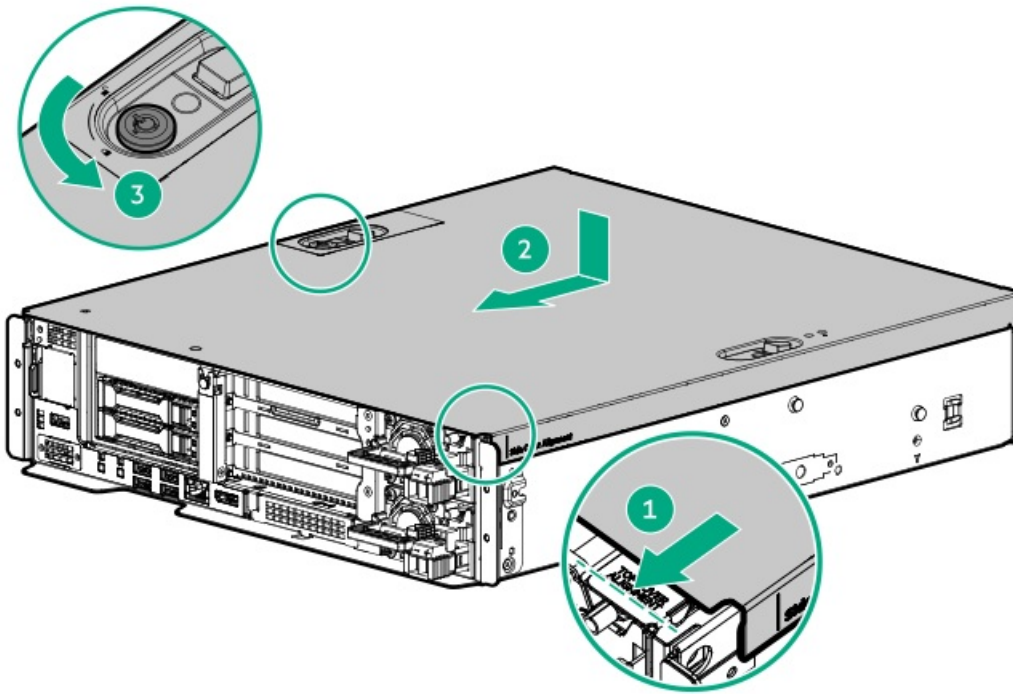

2. Perform the post-installation or maintenance steps required by the procedure that necessitates the removal of the access panel.

Power up the server

Procedure

- Press the Power On/Standby button.
- Use the virtual power button through iLO 6.

Hardware options installation

This chapter provides instructions for installing supported hardware options. To ensure proper server deployment and operation, Hewlett Packard Enterprise recommends installing only HPE-validated hardware options. To see the list of validated options for this server, see the product QuickSpecs on the HPE website:

<https://www.hpe.com/info/quickspecs>

To view the warranty for your server and supported options, see [Warranty information](#).

Subtopics

[Server data backup](#)

[Hardware option installation guidelines](#)

[Hewlett Packard Enterprise product QuickSpecs](#)

[Rack mounting options](#)

[Wall mounting and desktop installation options](#)

[Installing the front bezel option](#)

[Front bezel filter replacement kit option](#)

[Power supply options](#)

[Drive options](#)

[Drive cage options](#)

[Fan options](#)

[Memory option](#)

[Stacking riser options](#)

[Storage controller options](#)

[Energy pack option](#)

[Expansion card options](#)

[HPE NS204i-u Boot Device option](#)

[OCP NIC 3.0 adapter option](#)

[Chassis intrusion detection switch option](#)

[Serial port option](#)

Server data backup

To avoid data loss, make sure to back up all server data before installing or removing a hardware option, performing a server maintenance, or a troubleshooting procedure.

Server data in this context refers to information that may be required to return the system to a normal operating environment after completing a hardware maintenance or troubleshooting procedure. This information may include:

- User data files
- User account names and passwords
- Application settings and passwords
- Component drivers and firmware
- TPM recovery key/password
- BIOS configuration settings—Use the backup and restore function in UEFI System Utilities. For more information, see the UEFI user guide (<https://www.hpe.com/support/hpeuefismystemutilities-quicklinks>).
 - Custom default system settings
 - Security passwords including those required for power-on and BIOS admin access, persistent memory, and Server Configuration Lock (for HPE Trusted Supply Chain servers)
 - Server serial number and the product ID
- iLO-related data—Use the iLO backup and restore function. For more information, see the iLO user guide (<https://www.hpe.com/support/hpeilodocs-quicklinks>).
 - iLO license
 - Customer iLO user name, password, and DNS name
 - iLO configuration settings

Hardware option installation guidelines



WARNING

To reduce the risk of personal injury from hot surfaces, allow the drives and the internal system components to cool before touching them.





CAUTION

To avoid data loss, Hewlett Packard Enterprise recommends that you back up all server data before installing or removing a hardware option, or performing a server maintenance or troubleshooting procedure.



CAUTION

To prevent damage to electrical components, properly ground the server before beginning any installation, removal, or replacement procedure. Improper grounding can cause electrostatic discharge.

- Install any hardware options before initializing the server.
- If multiple options are being installed, read the installation instructions for all the hardware options to identify similar steps and streamline the installation process.
- If the hardware option installation involves internal cabling, review the Cabling guidelines.

Hewlett Packard Enterprise product QuickSpecs

To learn more about your product, search the Hewlett Packard Enterprise website (<https://www.hpe.com/info/quickspecs>) for the product QuickSpecs:

- Supported options
- Supported configurations
- Component compatibility
- New features
- Specifications
- Part numbers

Rack mounting options

Subtopics

[Four-post rack mounting options](#)

[Two-post rack mounting options](#)

Four-post rack mounting options

Installation of the server in a standard four-post rack requires the following options:

- [Rack enablement option kit \(P72008-B21\)](#)
- [Rack rail option](#):

Use the quick-deploy, toolless HPE [rack rail option](#) to install the server in a standard four-post rack. The rail design supports installation on rack of [different mounting interfaces](#).

For cable management, the rack rail kit might include one or both of the following options:



- [Rack rail hook-and-loop strap](#)
- [Cable management arm](#)

For more information on the rack mounting options, see the product QuickSpecs (<https://www.hpe.com/info/quickspecs>)

Subtopics

[Rack enablement option](#)

[Installing the rack mount brackets on the server](#)

[Rail identification markers](#)

[Rack mounting interfaces](#)

[Rack rail option](#)

[Installing the server into a four-post rack](#)

[Installing the rack rail hook-and-loop strap](#)

[Preparing the cable management arm](#)

[Installing the cable management arm](#)

Rack enablement option

This server requires the rack enablement option kit (P72008-B21) to support installation on a rack rail. The option kit includes two rack mount brackets.

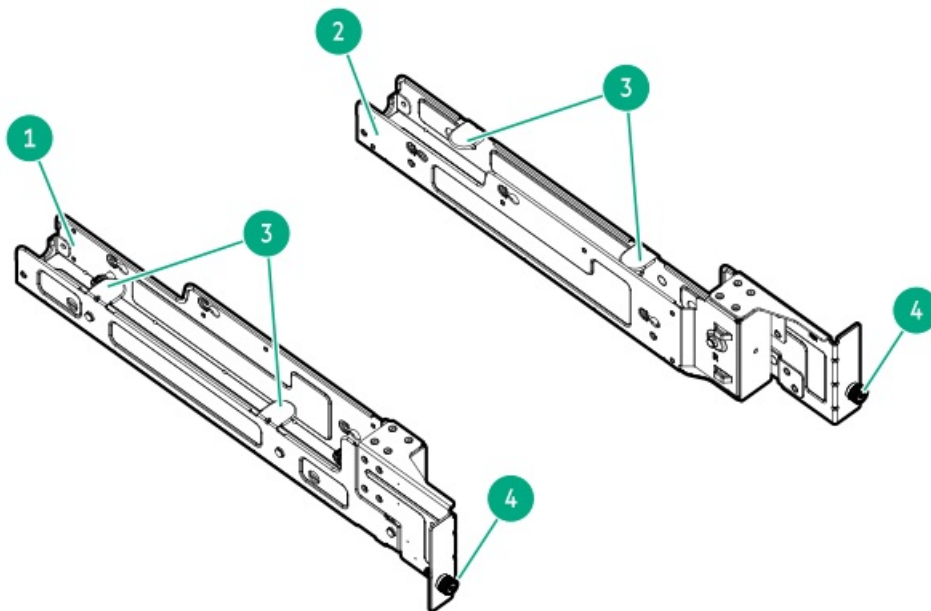

Item	Description
1	Left rack mount bracket
2	Right rack mount bracket
3	Cable management tabs
4	Shipping screws

For more information on the installation procedure, see [Installing the rack mount brackets on the server](#) .



Installing the rack mount brackets on the server

Prerequisites

- Review the [Rack enablement option](#).
- Before you perform this procedure, make sure that you have the following items available:
 - Torque screwdriver with T-15 Torx bit
 - T-10 Torx screwdriver

Procedure

1. If installed, remove the front bezel.
2. Power down the server.
3. Remove all power:
 - a. Disconnect each power cord from the power source.
 - b. Disconnect each power cord from the server.
4. Disconnect all peripheral cables from the server.
5. Place the server on a flat, level work surface.
6. If side covers are installed, do the following:
 - a. Remove the side covers.

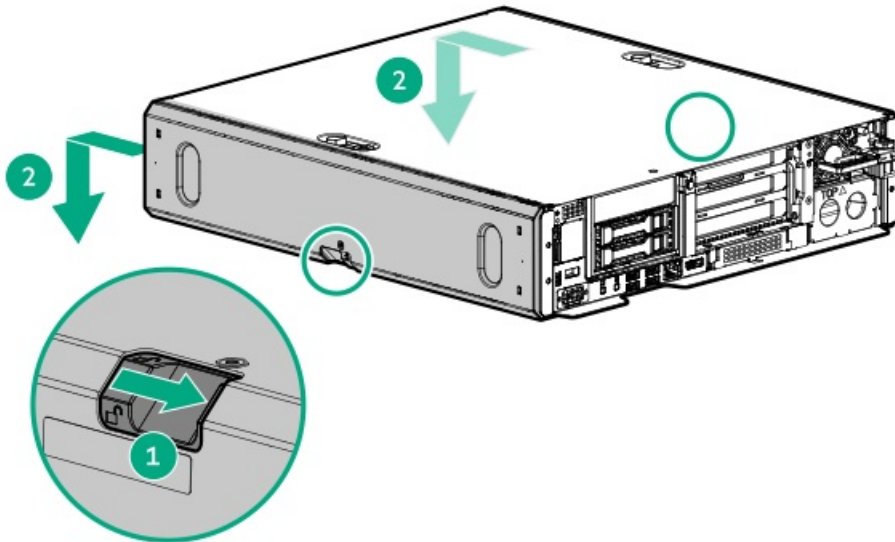

- b. Remove the side cover brackets.

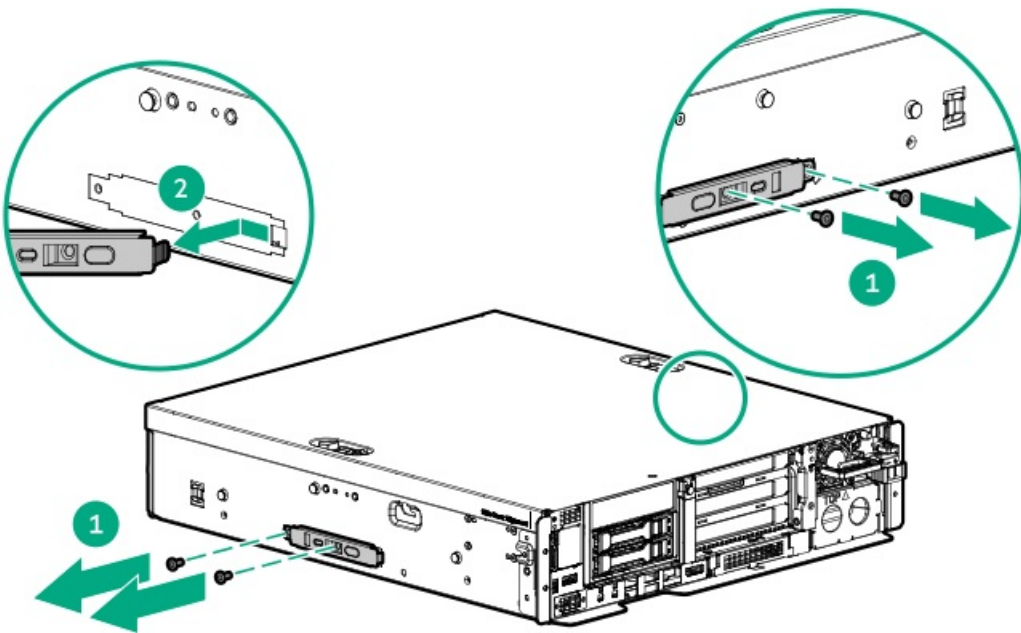

7. Install the left rack mount bracket:

- a. Insert the spools on the chassis through the keyed slots on the rack mount bracket.
- b. Slide the bracket toward the front panel to lock it into place.
A click sound indicates that the bracket is properly engaged.
- c. Tighten the two thumbscrews on the bracket.

Verify that the thumbscrews are properly tightened, and torque the thumbscrews to 0.68 N·m (6.00 lbf-in).

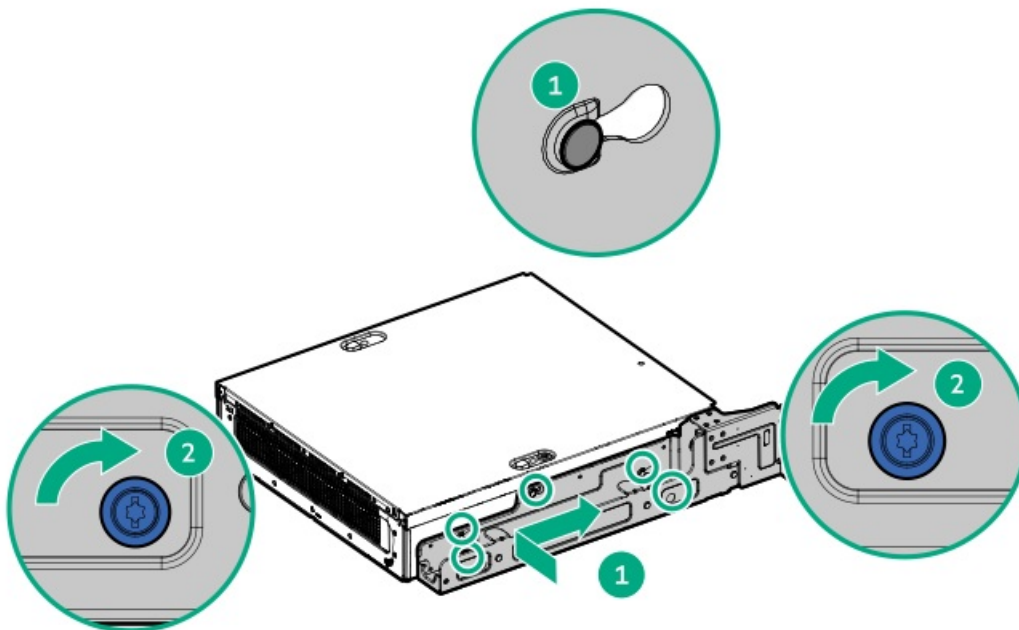

8. Repeat step 7 to install the right rack mount bracket.



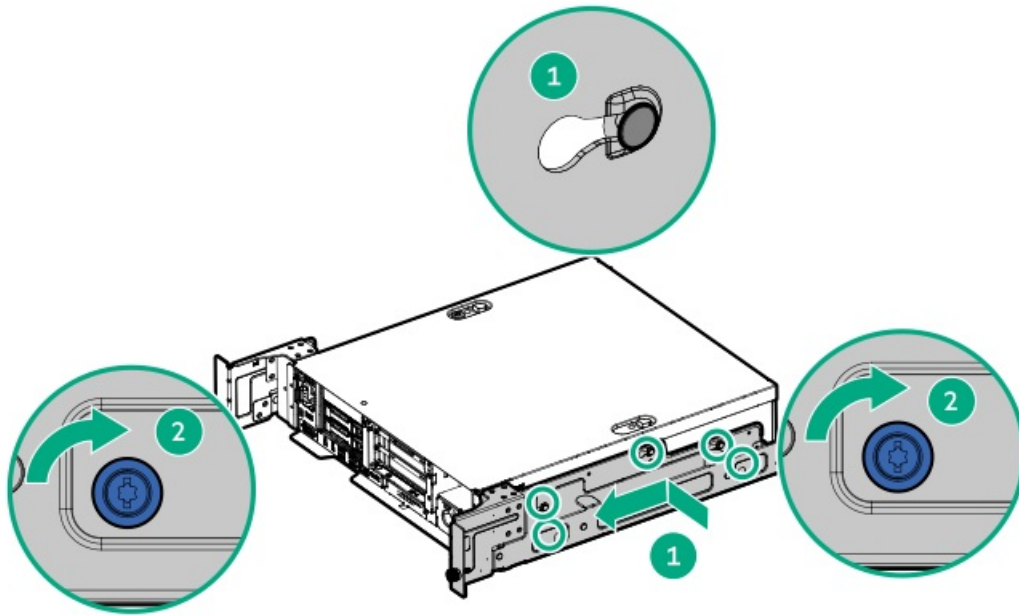

Results

The installation procedure is complete.

Rail identification markers

The rack rail option support is dependent on these two factors:

- The height and weight of the chassis as determined by the front- and rear-end server configurations.
- The depth of the chassis as measured from the edge of the front panel (without the front bezel) to the edge of the rear panel.

To ensure compatibility between the rack rails and the server, verify that the rail number labels on the rack enablement option kit match the ones stamped on the rails.

- Rail number labels on the rack enablement option kit

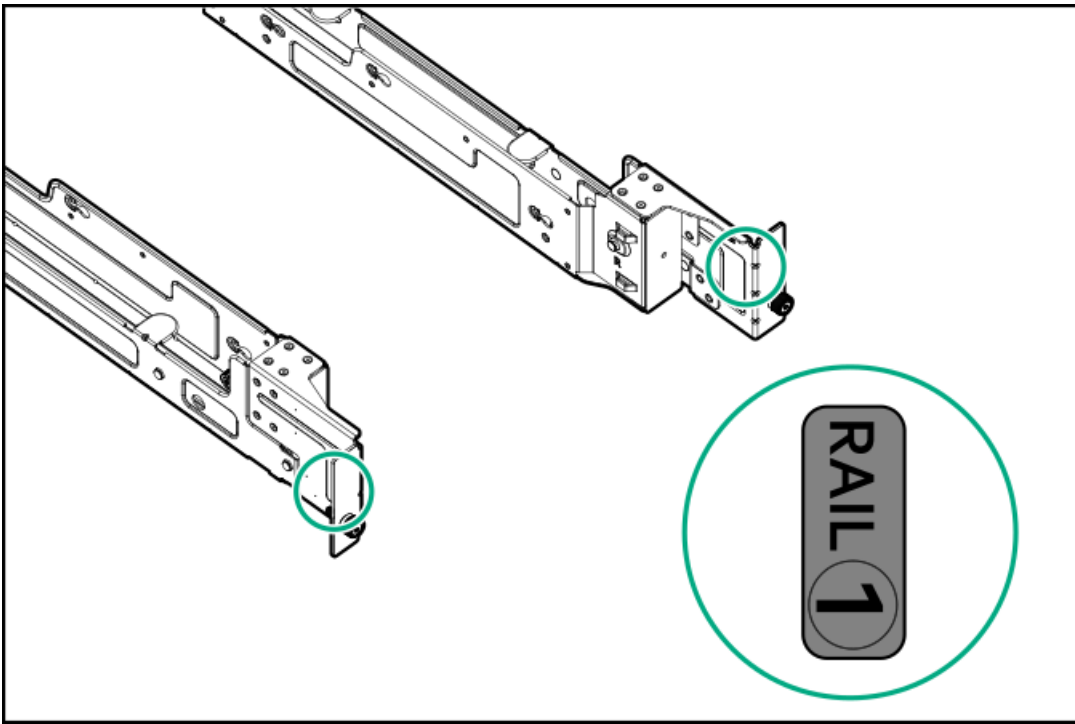

- Rail identifier stamps on the inner rail of the friction rack rail

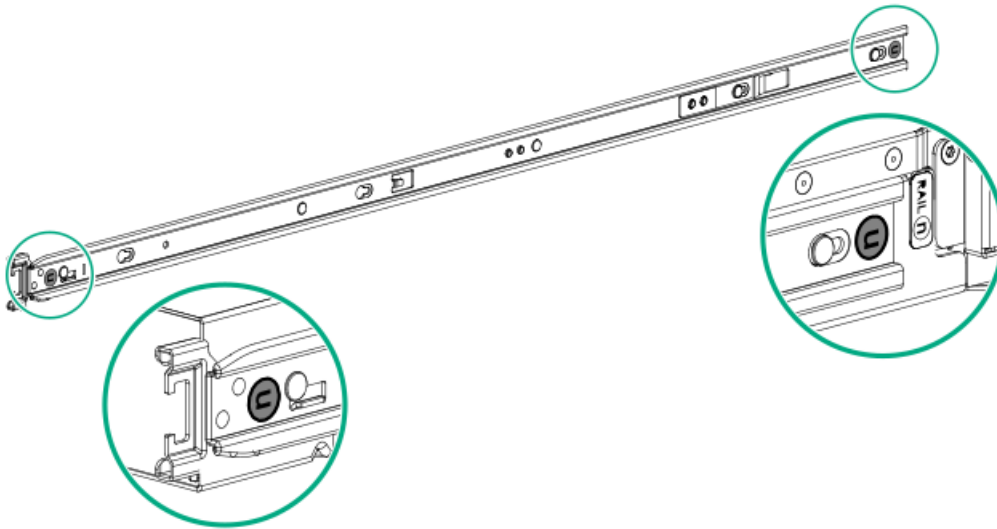

- Rail identifier stamps on the mounting rail of the friction rack rail

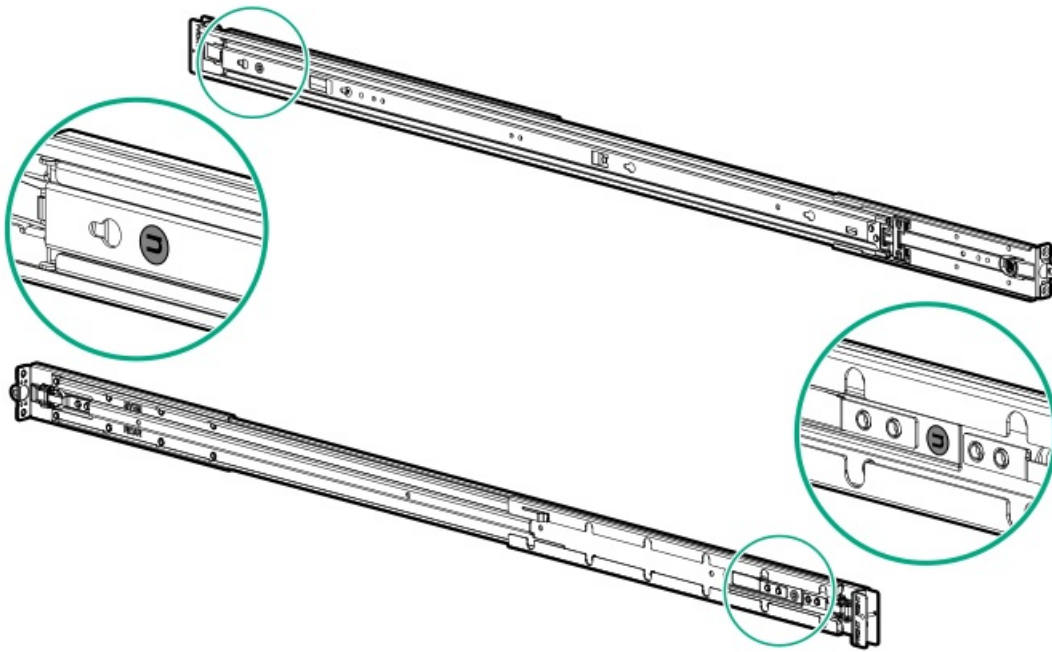

Rack mounting interfaces

The rack rails can be installed in a rack that has the following mounting interfaces:

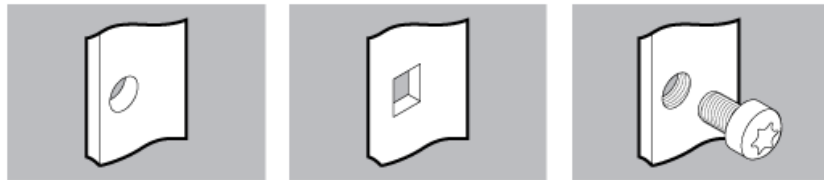

Round-hole

Square-hole

Threaded round-hole

The illustrations used in this procedure show an icon on the upper right corner of the image. This icon indicates the type of mounting interface for which the action illustrated in the image is valid.

Rack rail option

This server supports the following rack rail option:

Server configuration	Rack rail option	Type	Minimum rail length	Adjustable rail range
SFF/E3.S drive configuration*	Rail option #1 (P52349-B21)	Friction rack rail (stab-in)	674.20 mm (26.54 in)	609.60 mm to 867.30 mm (24.00 in to 34.00 in)

* To support installation on a rack rail, the rack enablement option kit (P72008-B21) is required.

For more information on the installation procedure, see [Installing the rack rail](#).

Subtopics

[Installing the rack rail](#)

Installing the rack rail

Prerequisites

- The [rack enablement option](#) is installed.
- Review the [Rail identification markers](#).
- Before you perform this procedure, make sure that you have a small slotted screwdriver available. This tool is required if you intend to install the server in a threaded round-hole rack.

Procedure

Installing the inner rails on the rack mount

1. Attach the inner rails to the rack mount:
 - a. Insert the spools on the sides of the rack mount brackets through the keyed slots on the rails.
 - b. Slide the rails towards the rear panel to lock them into place.

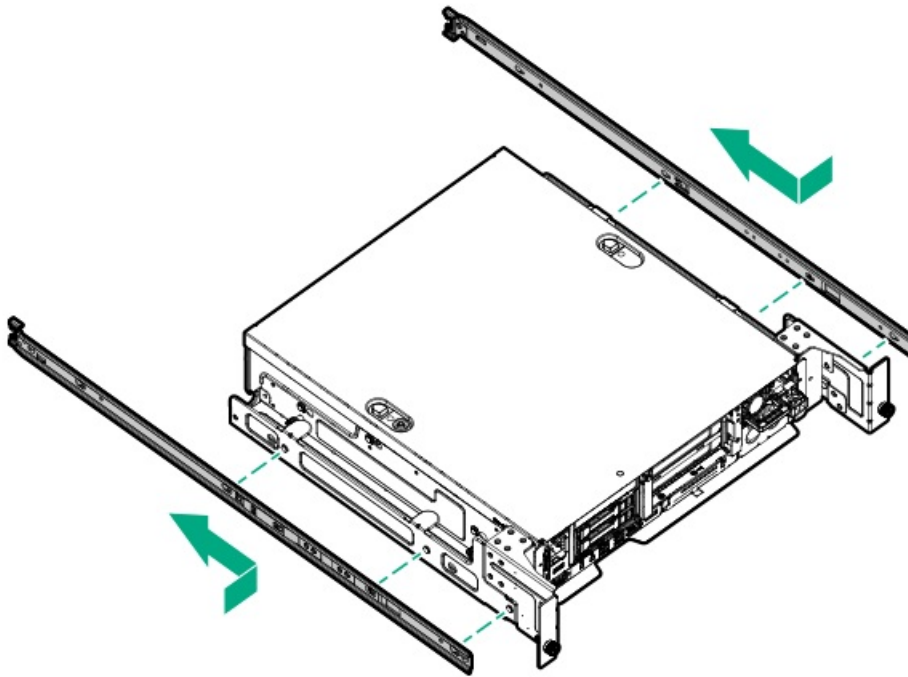

Installing the mounting rails on the rack

2. Locate the orientation markers on the mounting rails.
 - The front end of the rails is marked as **FRONT LEFT** or **FRONT RIGHT**.
 - The other end of the rails is marked as **REAR**.

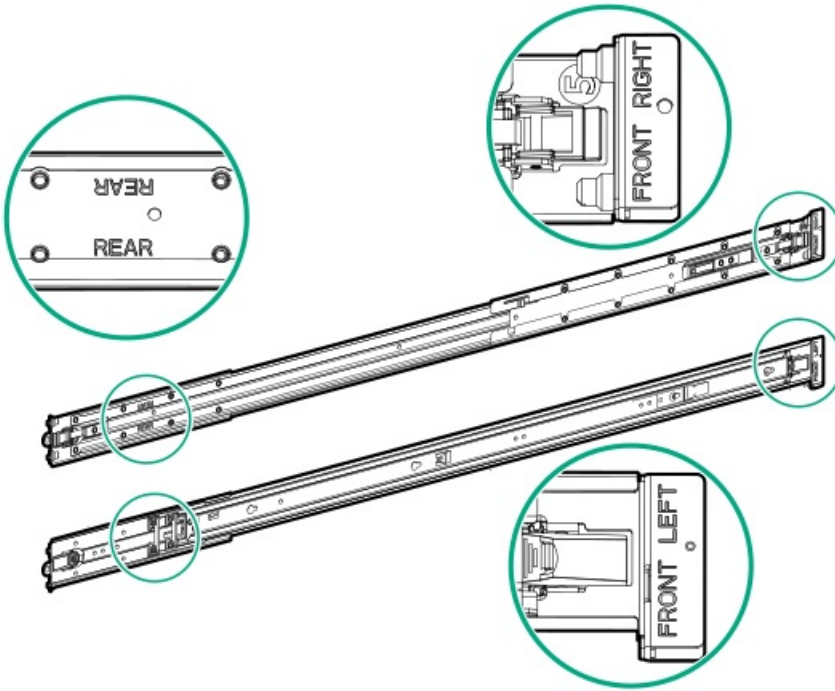

3. Extend the mounting rails to align with the depth of the rack.
4. To install the mounting rails in a round-hole or square-hole rack, insert the pins on the mounting flanges into the rack post holes.

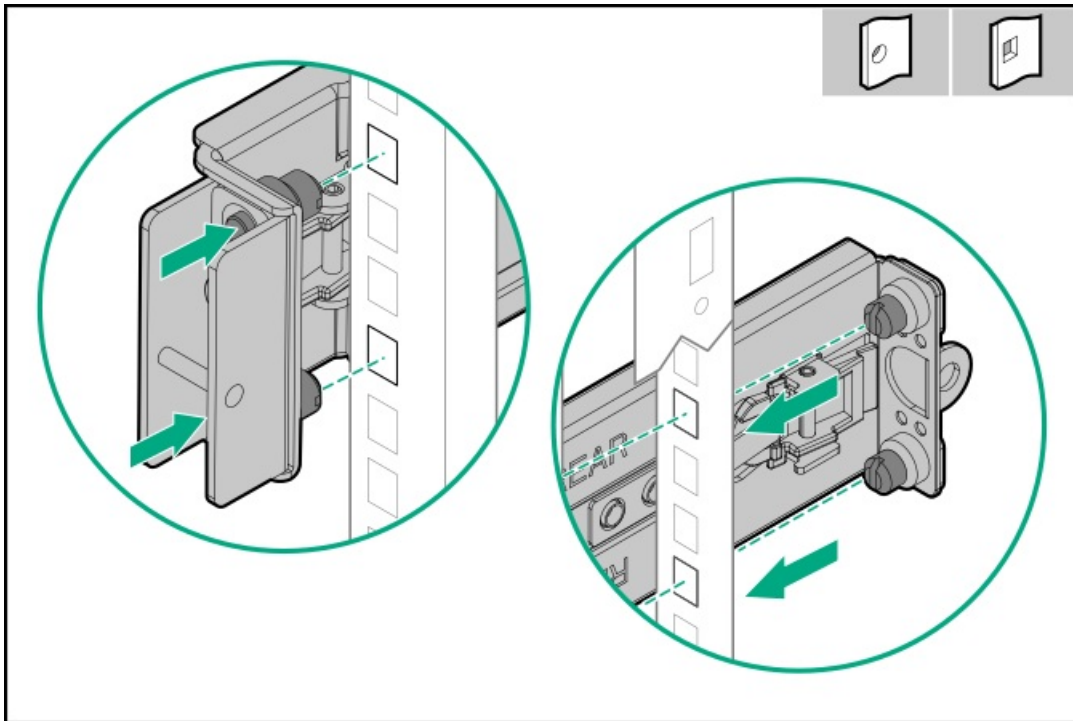

5. To install the mounting rails in a threaded round-hole rack, do the following:
 - a. Remove the pins and washers from the mounting rails.



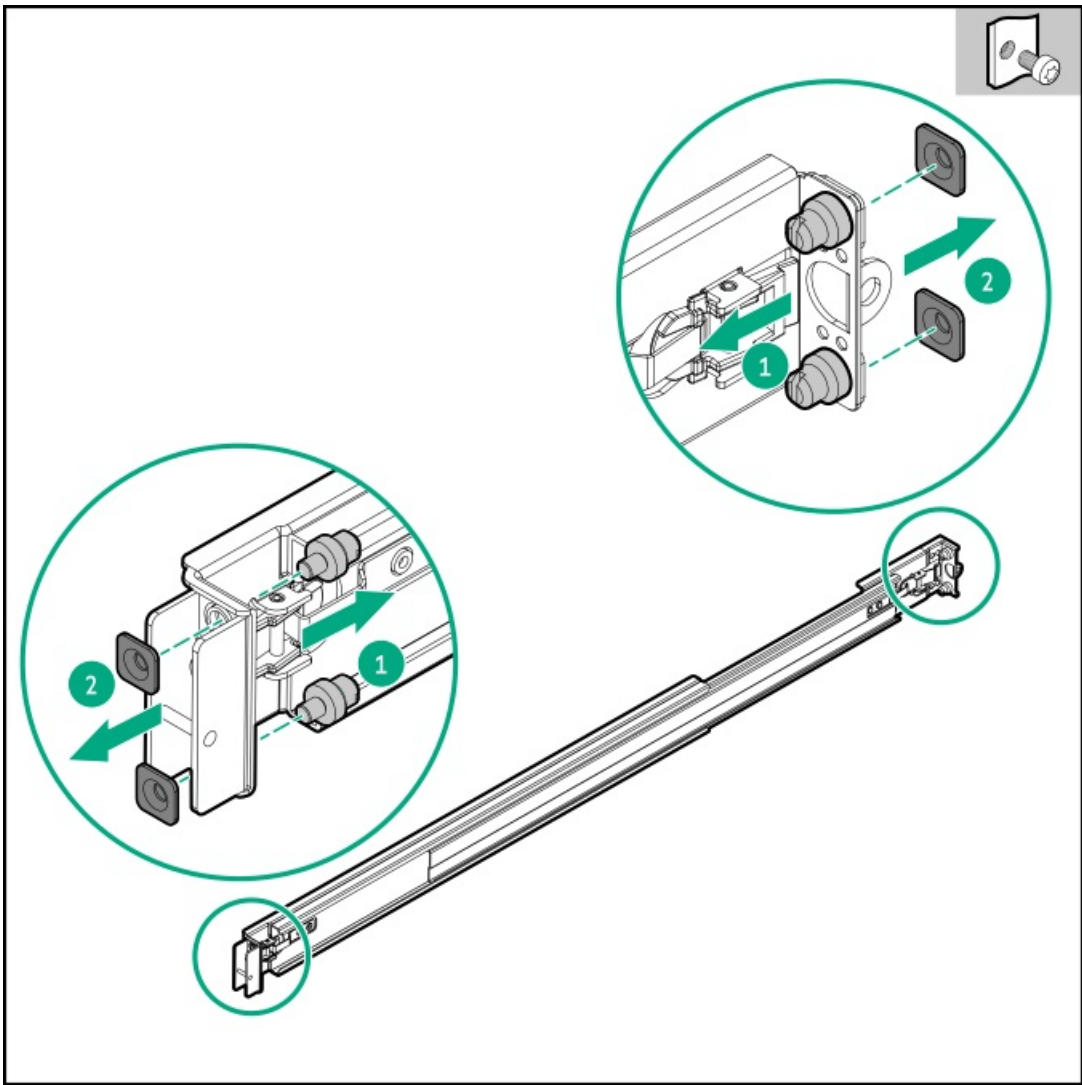

- b. Position the holes on the mounting flanges against the threaded holes on the rack post.
- c. Install the rack mounting screws.

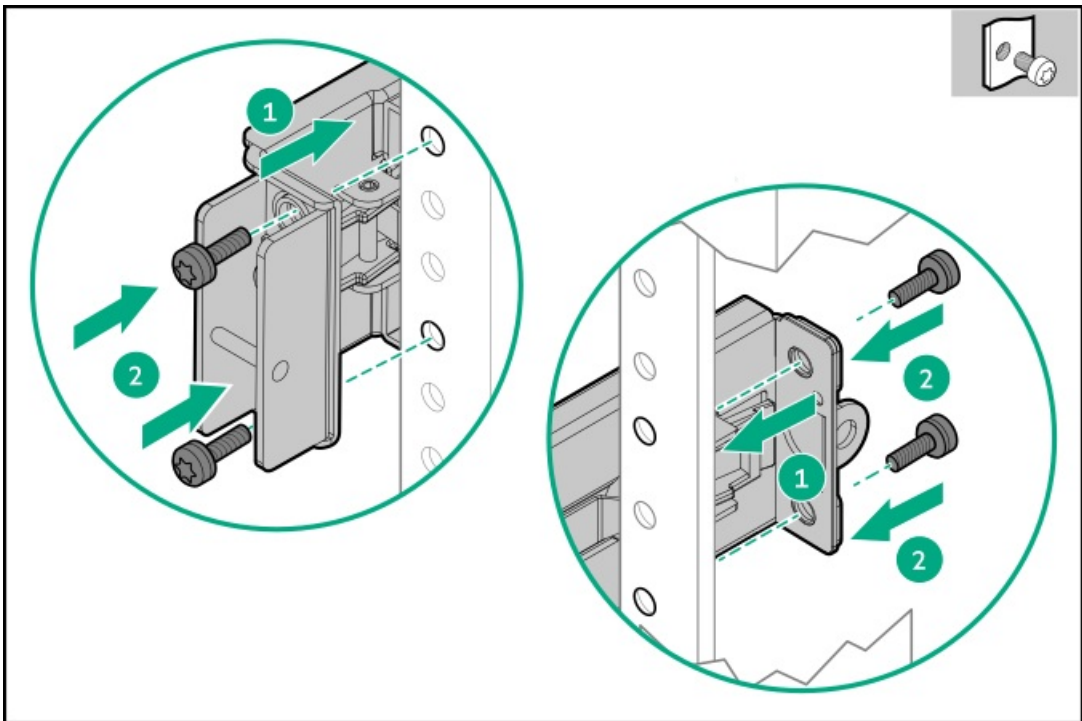

6. [Install the server into the rack.](#)

Results

The installation procedure is complete.

Installing the server into a four-post rack

Prerequisites

- Get help to lift and stabilize the server during rack installation. **If the server is installed higher than chest level, additional two people might be required to help install the server:** One person to support the server weight, and the other two to slide the server into the rack.
- Before you perform this procedure, review the:
 - [Space and airflow requirements](#)
 - [Rack warnings and cautions](#)
 - [Server warnings and cautions](#)
 - [Four-post rack mounting options](#)
- A fully populated server is heavy. Hewlett Packard Enterprise recommends removing the external chassis components before installing the server into a rack.
- The server has the [rack enablement option](#) and [rack rail option](#) installed.
- Before you perform this procedure, make sure that you have a torque screwdriver with T-25 Torx bit available.

Procedure

1. Extend the slide rails out on the mounting rails until they hit the internal stops and lock into place.

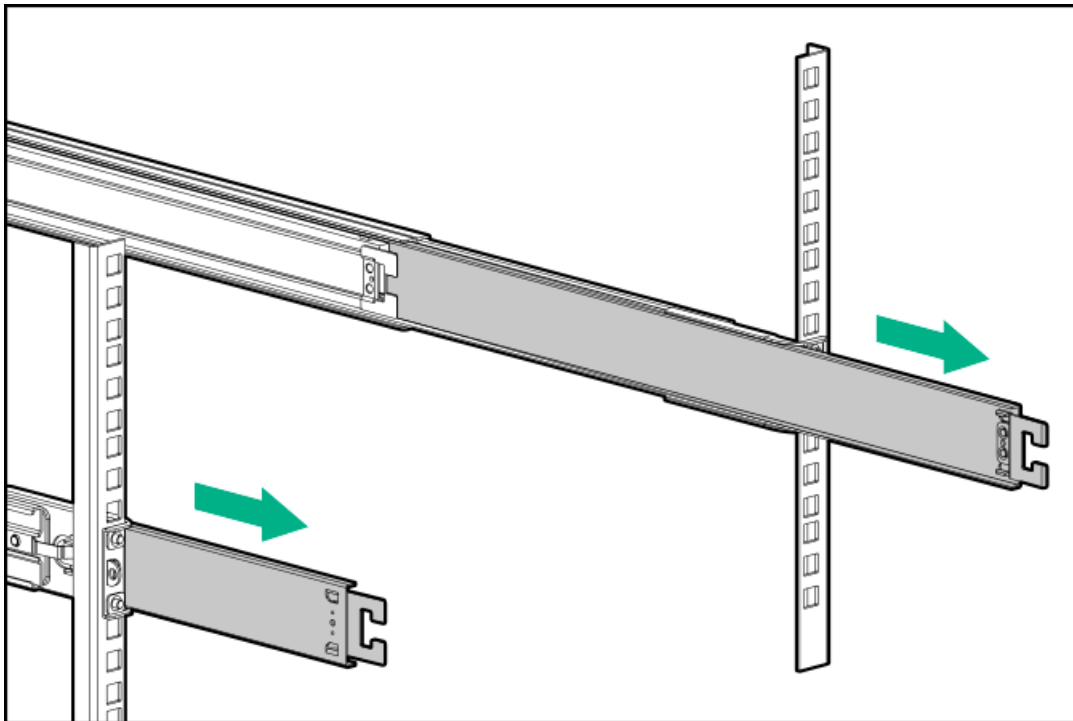

2. Install the server into the rack:
 - a. Insert the inner rails into the slide rails.



- b. Slide the server into the rack until the ears of the rack mount brackets are flush against the rack posts.

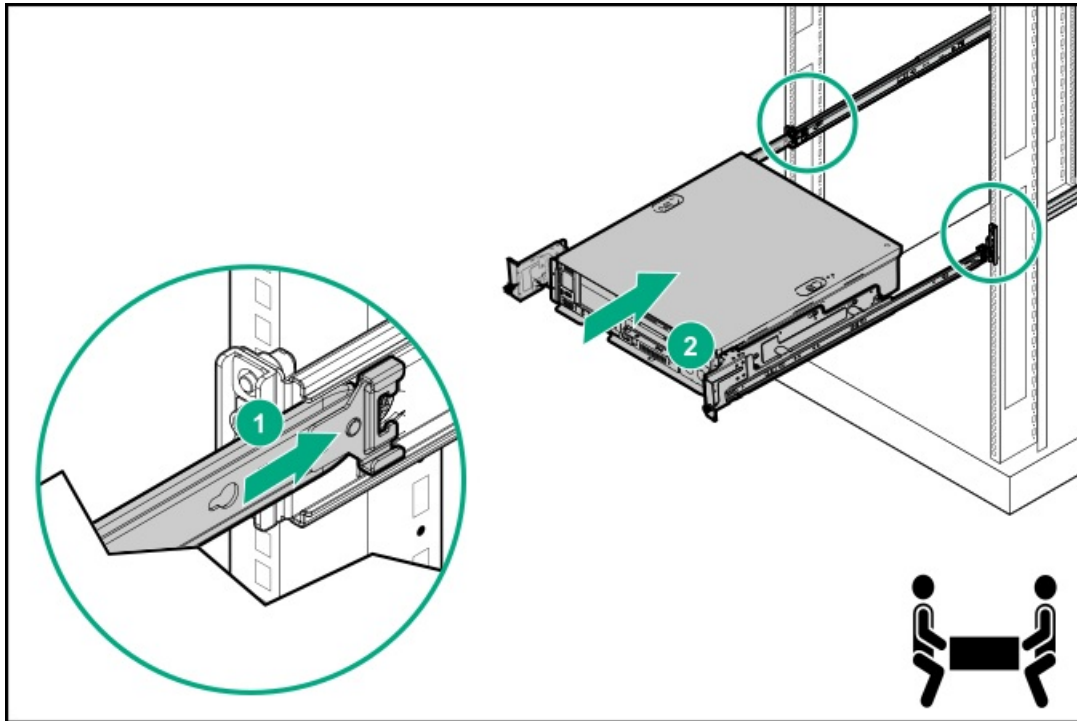

3. Tighten the shipping screws on the rack mount brackets.

HPE recommends applying 2.37 N·m (21 lbf-in) of torque to securely tighten the screws.

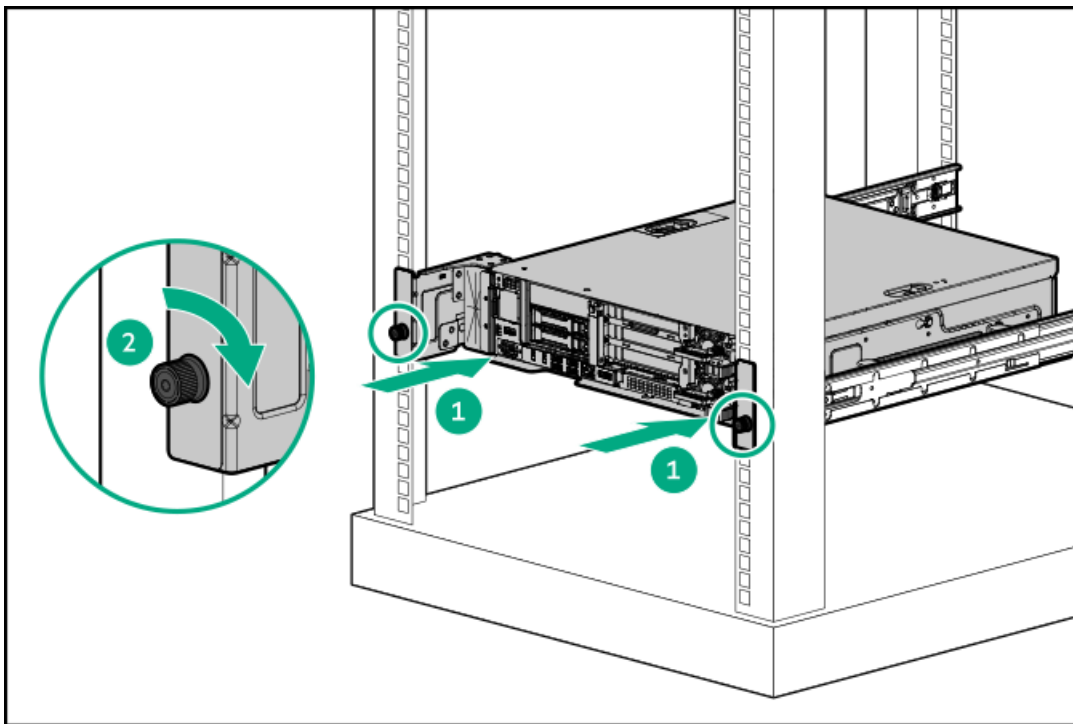

4. Route the server peripheral cables and power cords into the cable management channel on the rack mount to the front of the server.



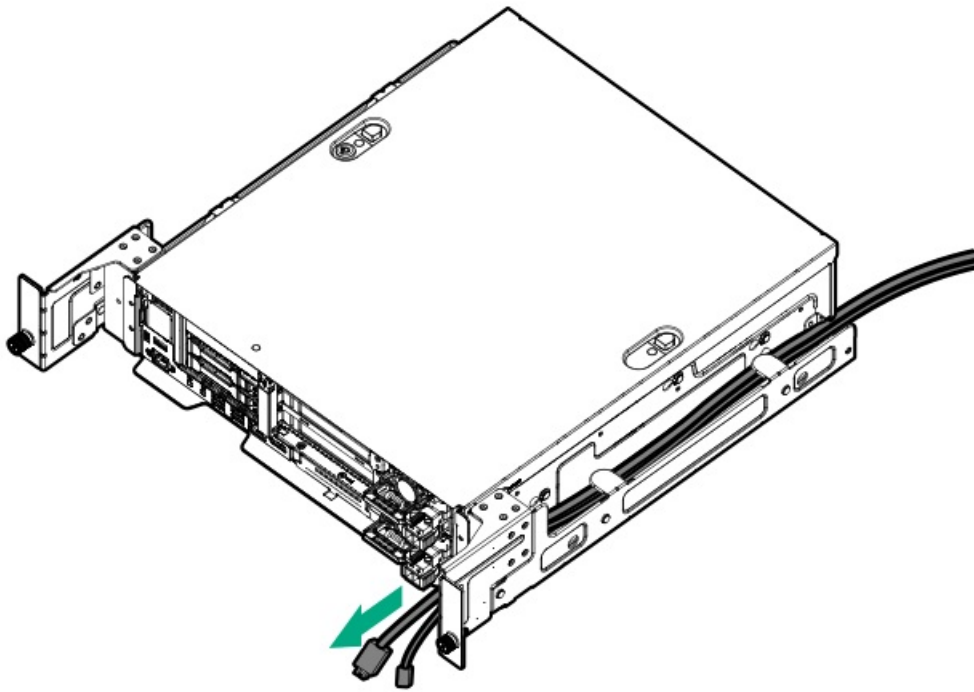

5. Connect all peripheral cables to the server.
6. Connect each power cord to the server.
7. Make sure that the server cables run under the cable management tabs on the rack mount.
8. Connect each power cord to the power source.
9. If installing the front bezel, do the following:
 - a. Route the server peripheral cables and power cords through the front bezel support brackets to the front panel.

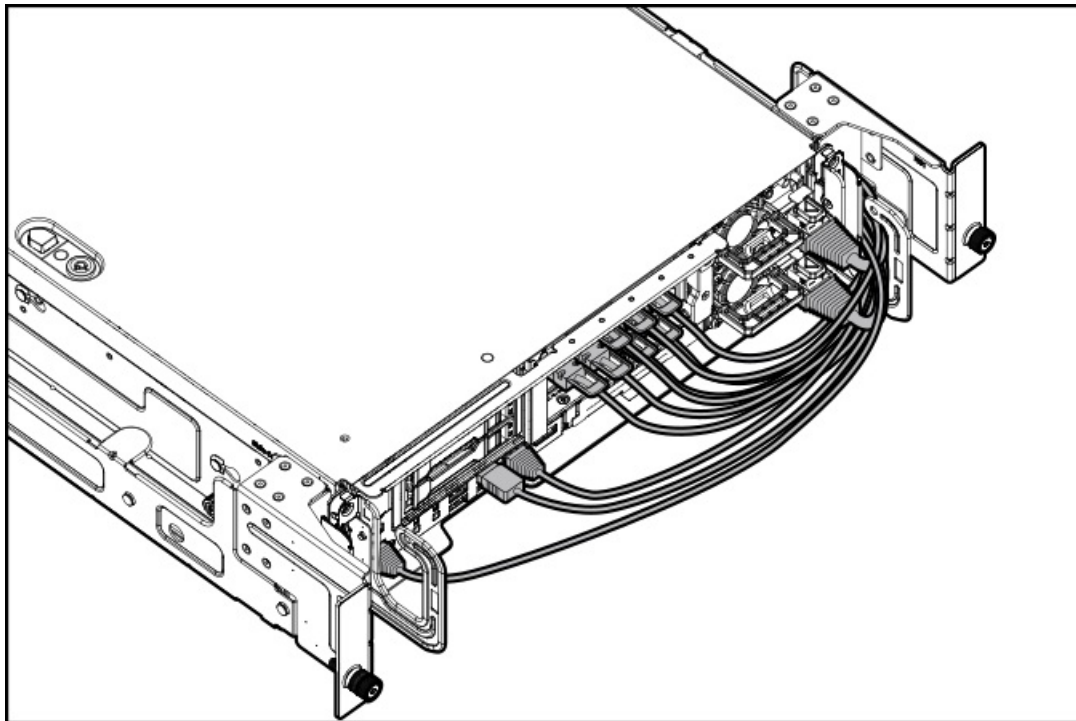

- b. Install the front bezel.

Results



The installation procedure is complete.

Installing the rack rail hook-and-loop strap

About this task

The hook-and-loop strap can be installed on either the left or right rail.

Procedure

1. Attach the strap carabiner to the rail.
2. Bundle the cords and cables, and then wrap the strap around the cables.

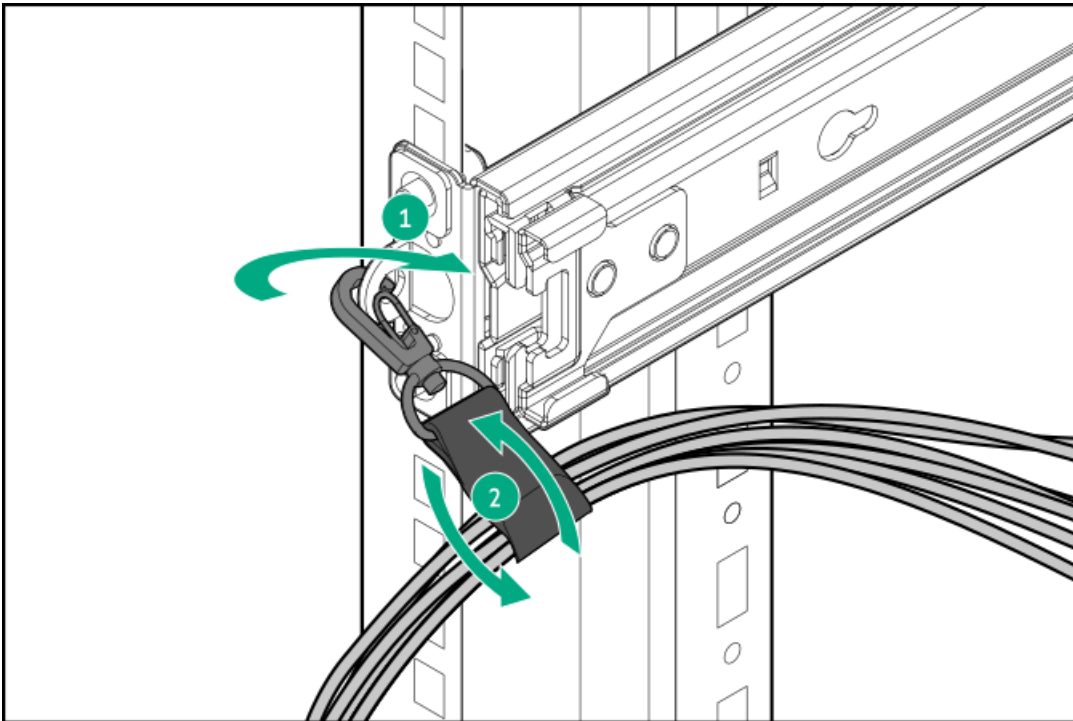

Results

The installation procedure is complete.

Preparing the cable management arm

About this task

The management arm can be installed to swing out from the left or right side of the rack. Before installing, rotate the elbow bracket according to your configuration.



NOTE

Your bracket might look different than the image below, but the procedure is the same.

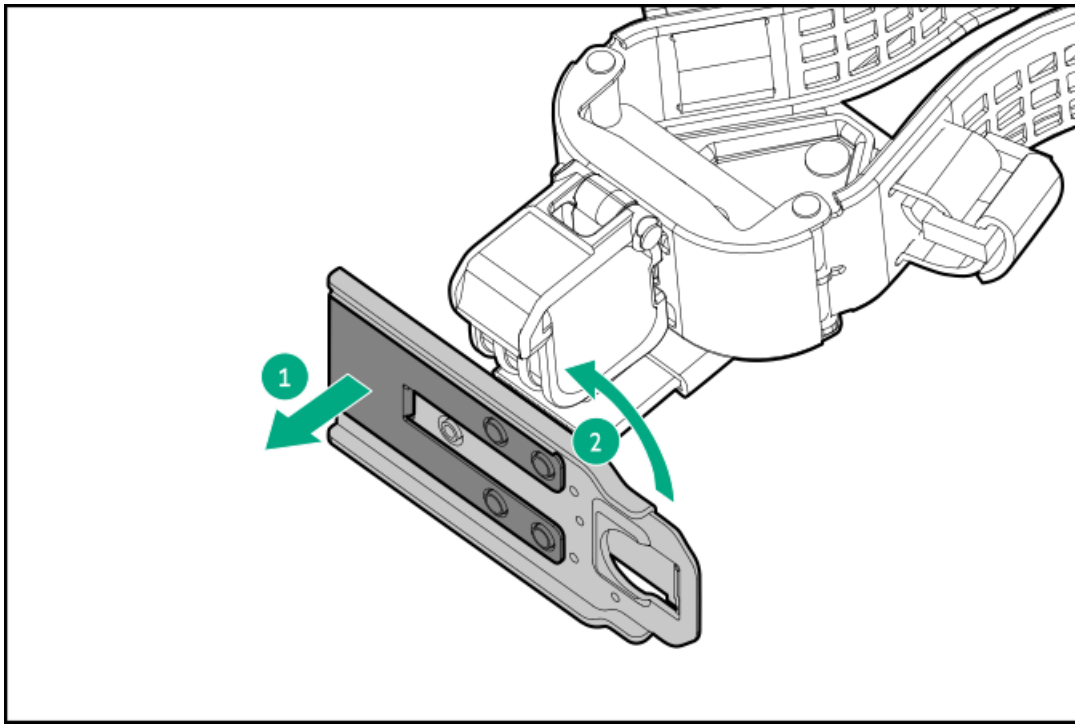

Installing the cable management arm

Prerequisites

- The server has the [rack enablement option](#) and [rack rail option](#) installed.
- Before you perform this procedure, review the [Rack warnings and cautions](#).
- T-25 Torx screwdriver—This tool is required if the shipping screws located on the rack mount brackets need to be loosened or tightened.

About this task

Identify the CMA cable baskets in the following illustration. Your management arm might look slightly different, but the procedures are the same.

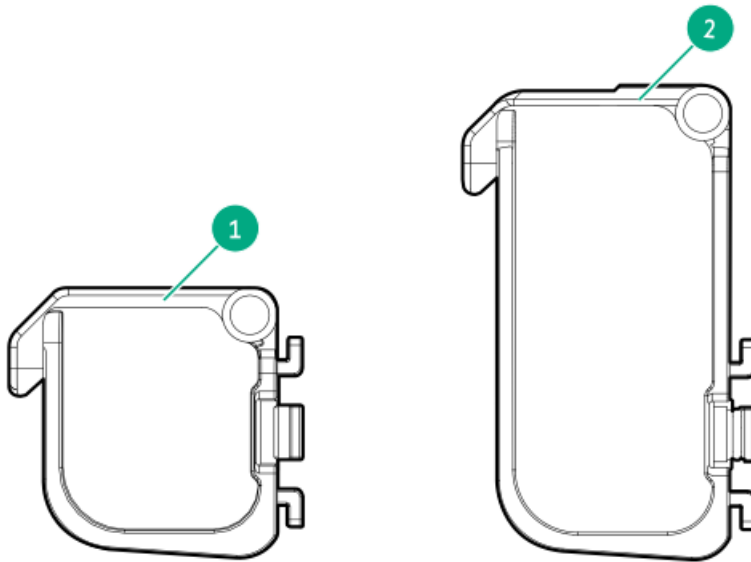

Item Description

- 1 1U CMA cable basket
- 2 2U CMA cable basket



IMPORTANT

Some management arms are designed to hold extra weight:

- P26489-B21
- P22020-B21
- P18546-B21

For these management arms, the angle of the brackets require the outer bracket to be removed before installing the elbow bracket.



CAUTION

To reduce the risk of personal injury, be careful when pressing the cable management or rail-release latches. The rails or latches could pinch your fingers.

Procedure

1. Connect and secure all peripheral cables and power cords to the server.
2. Make sure that the server cables run under the cable management tabs on the rack mount.
3. Prepare the management arm.
4. Install the CMA brackets to the inner and outer rails.



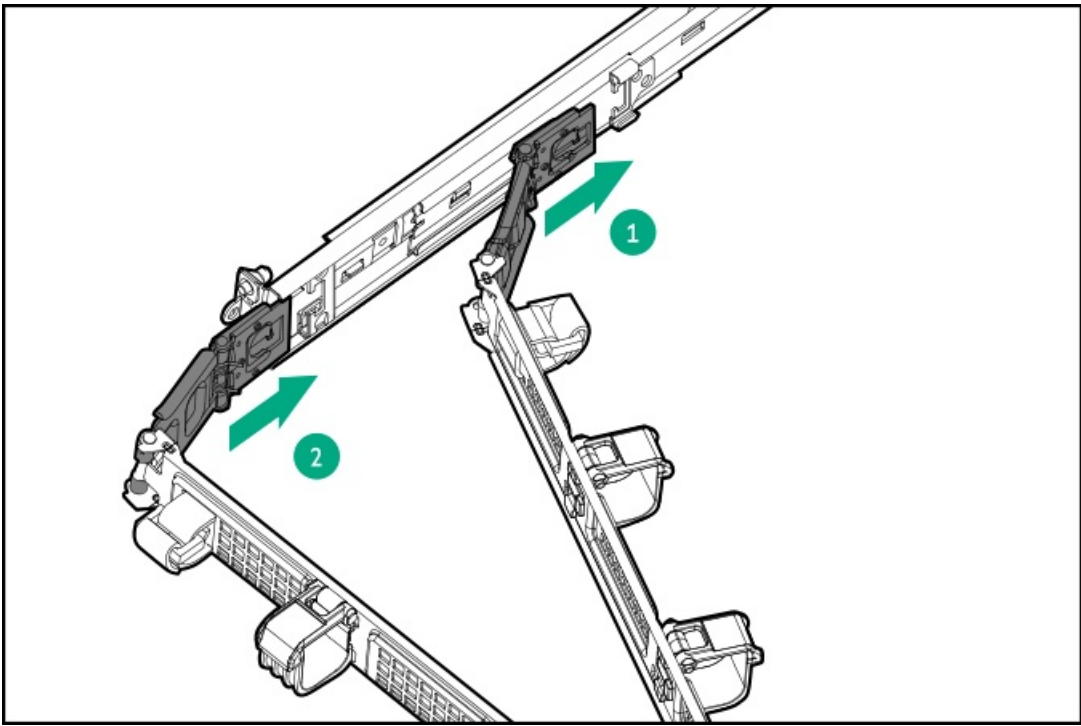

5. Open the straps and cable baskets.

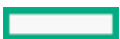
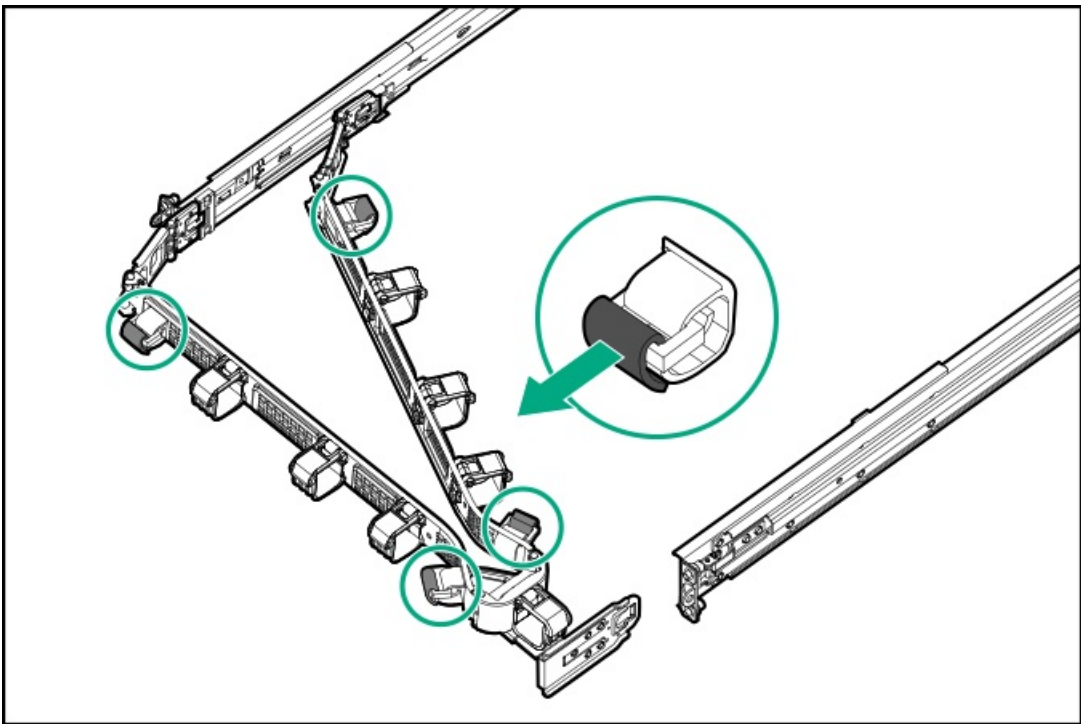

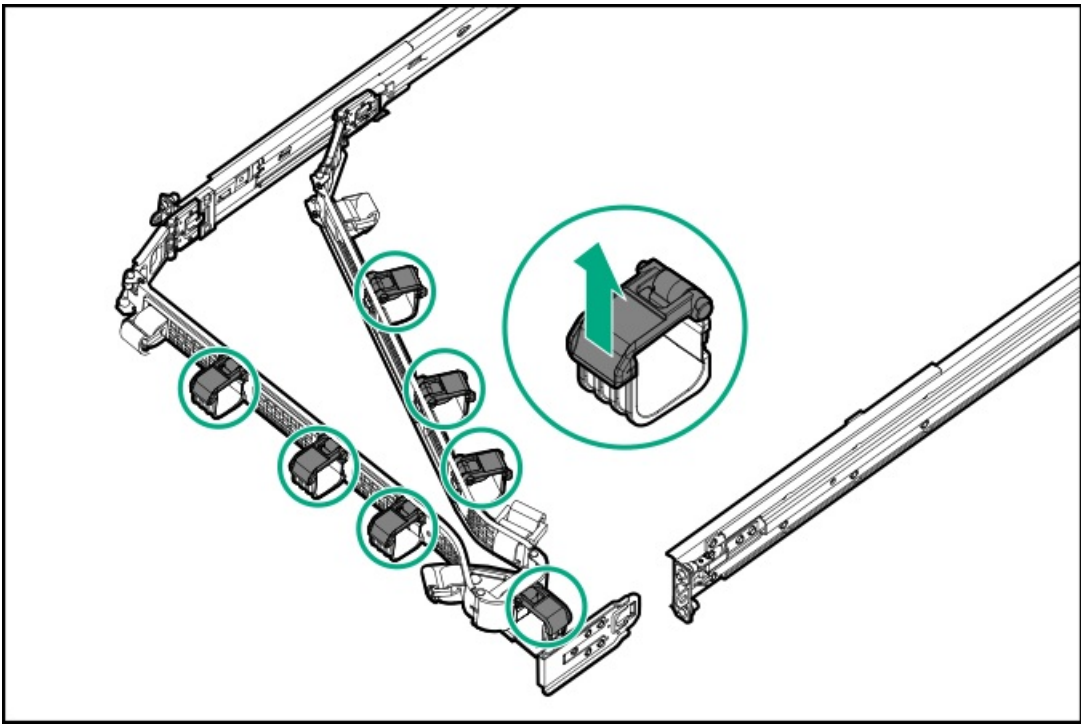

6. Install the cables.

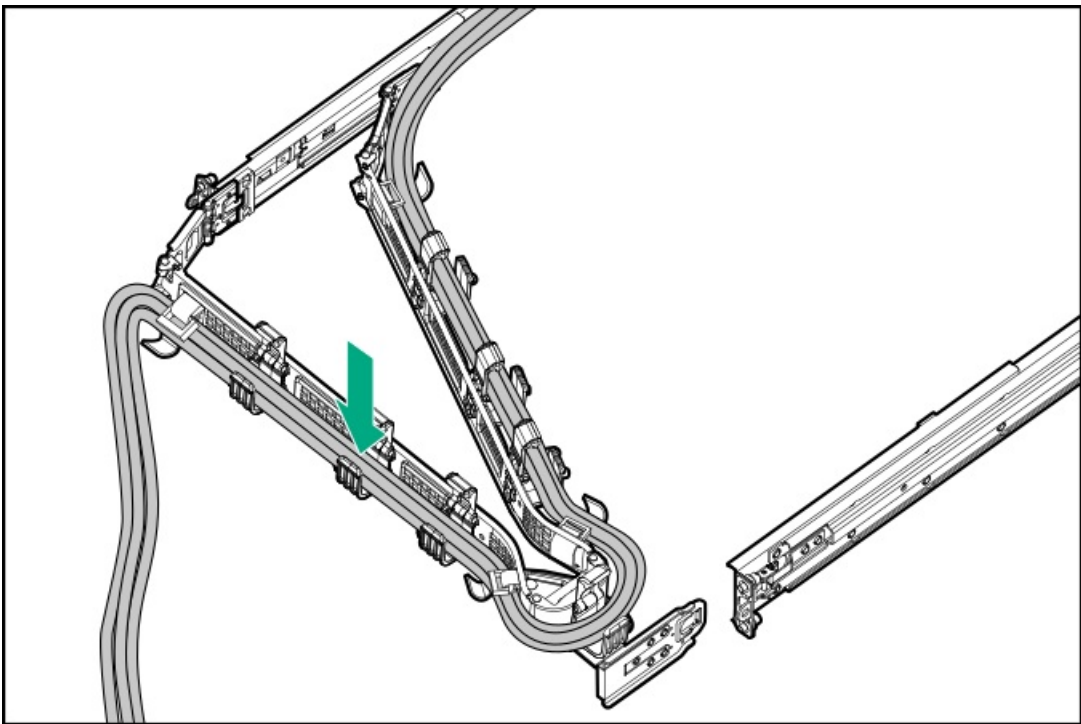

7. Close the baskets and secure the straps.



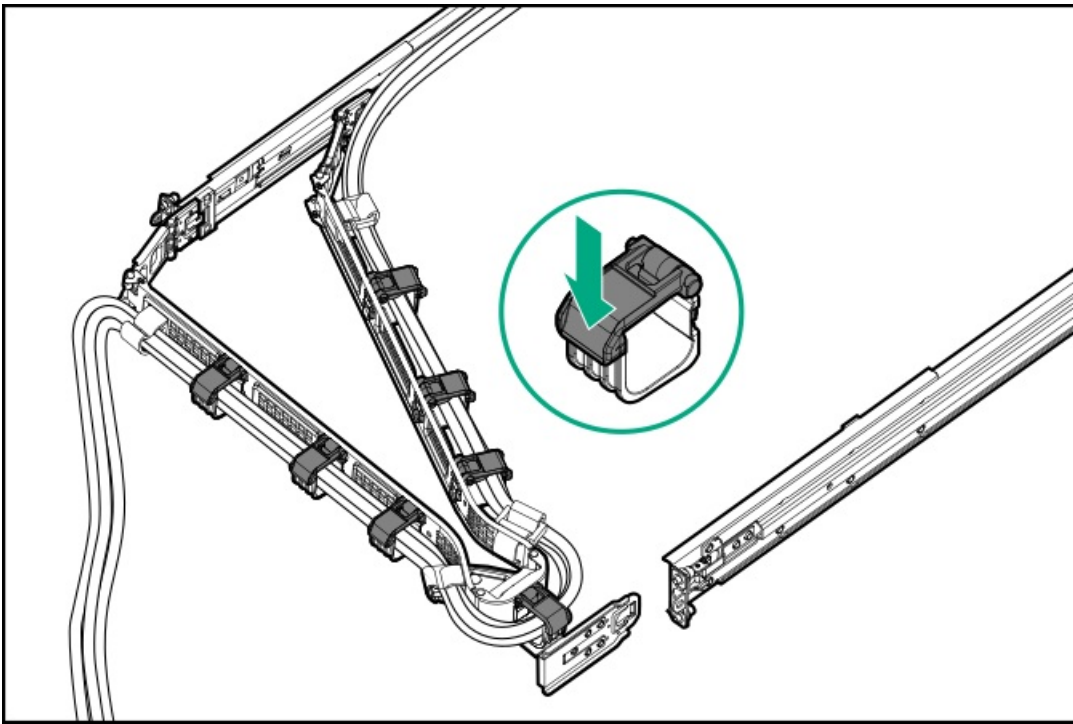

8. Install the elbow bracket to the outer rail.

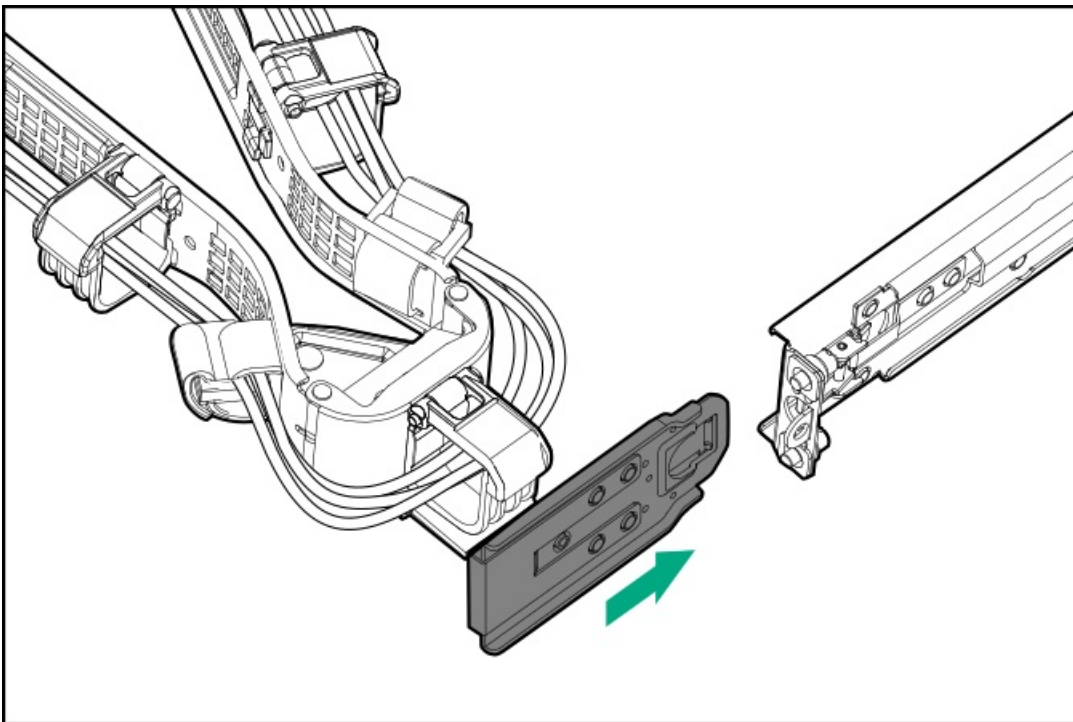

IMPORTANT

Some management arms are designed to hold extra weight:

- P26489-B21
- P22020-B21
- P18546-B21

The angle of the brackets require the outer bracket to be removed before installing the elbow bracket.

a. Remove the outer bracket.



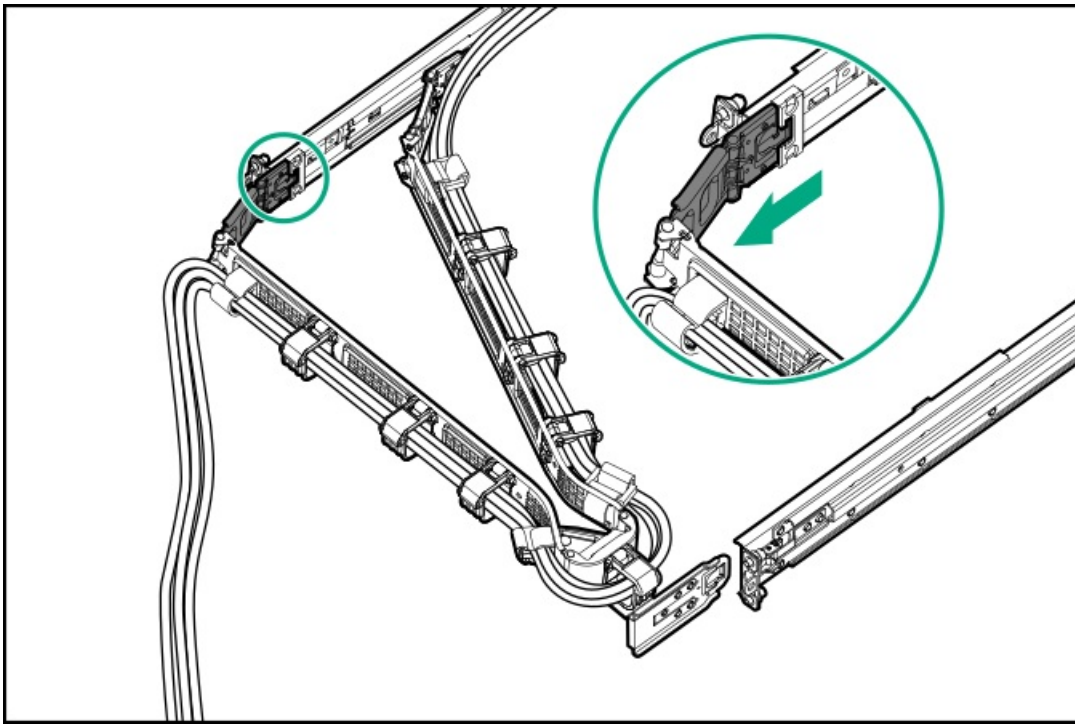

b. Align and install the elbow bracket.

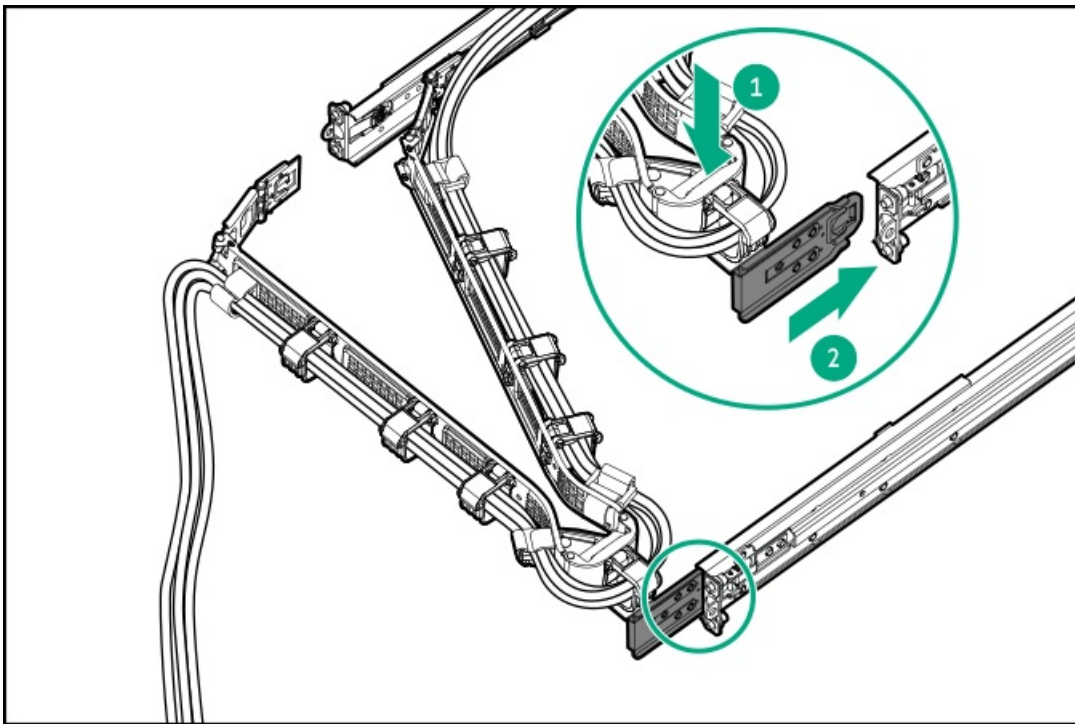

c. Install the outer bracket.



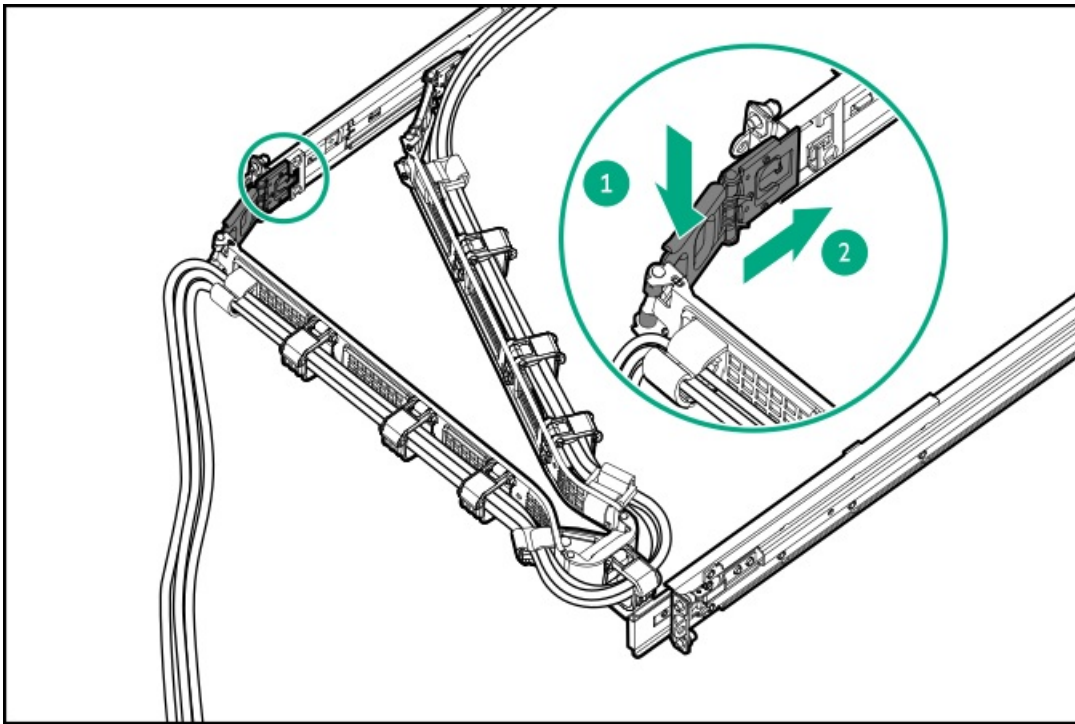

9. Verify the operation of the rack rails:

- a. Fully extend the chassis out of the rack.
- b. Check that there is enough slack in the cables and cords for full extension of the chassis. Make sure that there is no cable binding or crimping.
- c. To ensure that the cables and cords are secured properly, slide the chassis in and out of the rack. Make sure that there is no risk of accidental disconnection of the peripheral cables and power cords.

10. Slide the server into the rack until the ears of the rack mount brackets are flushed against the rack posts.

11. Tighten the shipping screws on the rack mount brackets.

HPE recommends applying 2.37 N·m (21 lbf-in) of torque to securely tighten the screws.

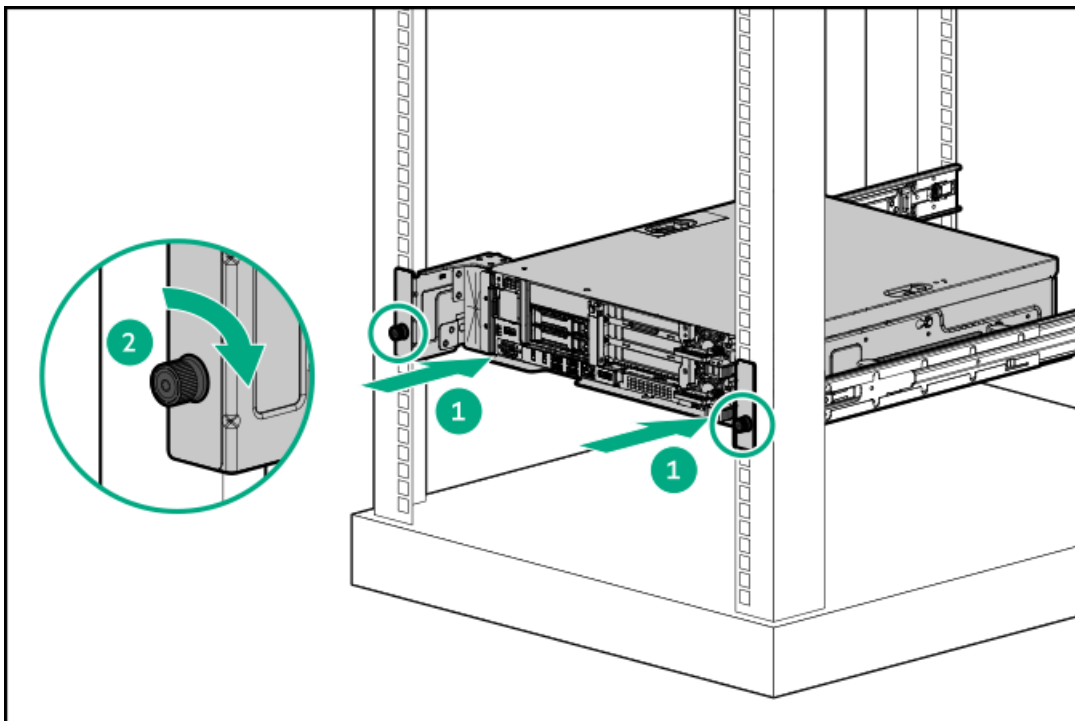

Results

The installation procedure is complete.

Two-post rack mounting options

Installation of the server in a two-post rack requires the following options:

- [Rack enablement option kit \(P72008-B21\)](#)
- [Two-post rack support kit \(P78764-B21\)](#)

For more information on the available mounting options, see the product QuickSpecs (<https://www.hpe.com/info/quickspecs>)

Subtopics

[Rack enablement option kit](#)

[Two-post rack support kit](#)

[Installing the server into a two-post rack](#)

Rack enablement option kit

The server with the rack enablement option kit installed can support installation in a two-post rack using the [two-post rack support kit](#). The rack enablement option kit includes two [rack mount brackets](#).

For more information on the installation procedure, see [Installing the rack mount brackets on the server](#).

Two-post rack support kit

Two-post rack support brackets

The two-post rack support kit includes the following:

- Left and right two-post rack support brackets
- Cage nuts and screws

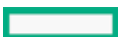

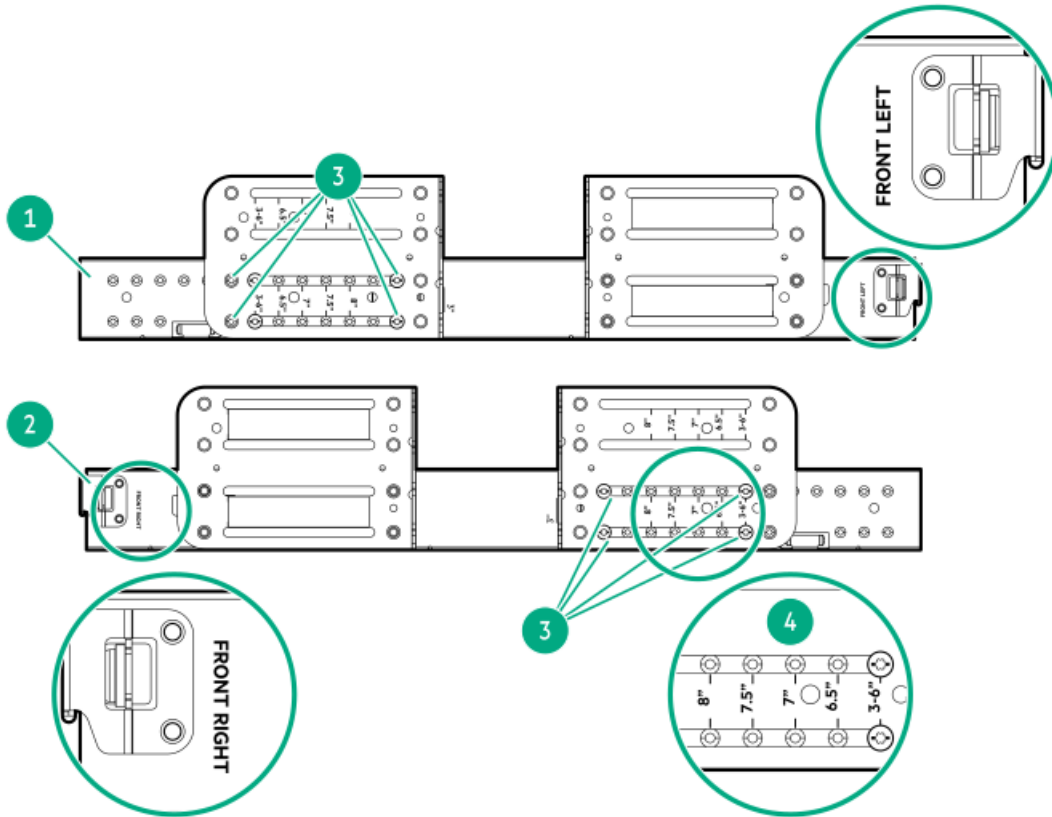

Item	Description
1	Left support bracket
2	Right support bracket
3	Adjustment screws—Remove these screws to adjust the position of the back bracket. The back bracket supports a range of rail depths (minimum 3.00 inches, maximum 8.00 inches). For more information, see Back bracket configuration .
4	Rail depth markers

For more information on the installation procedure, see [Installing the server into a two-post rack](#).

Back bracket configuration

The back brackets can be configured to support rack columns of different widths (minimum 3.00 inches, maximum 8.00 inches). Loosen the adjustment screws and align the front of the back bracket with the rail depth number that matches your rack, and install the screws at the corresponding screw positions.

Use the following table to determine the rail depth and the corresponding screw positions for the back bracket. Note the following information:

- The following illustration shows the right support bracket. The screw positions of the left and right support brackets are counted from front to back.
- The factory default position of the back bracket is at 3.00 in.
- The arrow points to the front of the server.
- Some screw positions are not supported.

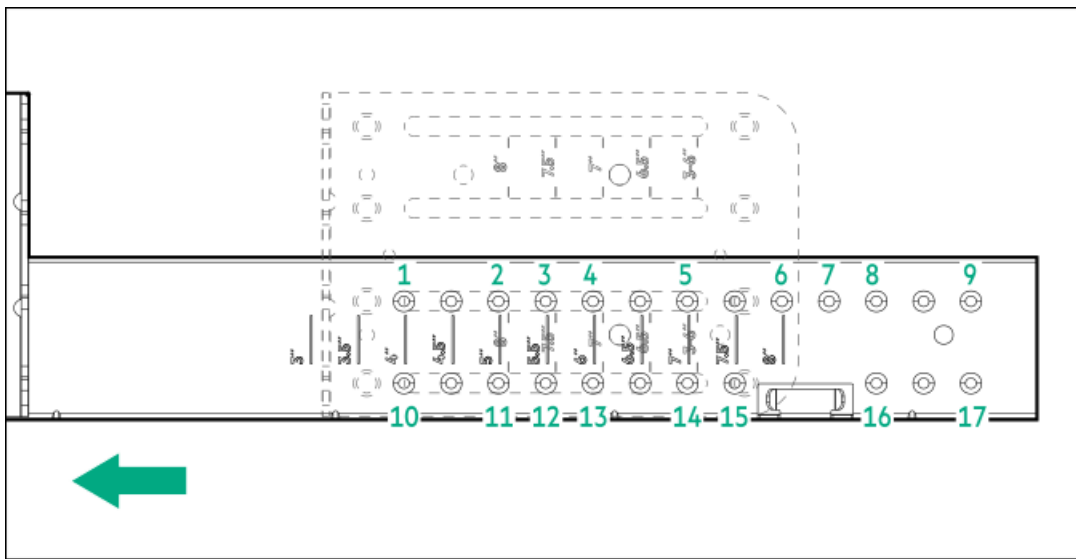

Rail depth Screw positions

3.00 in	1 & 10, 5 & 14
4.00 in	2 & 11, 6 & 15
4.50 in	3 & 12, 7 & 15
5.00 in	4 & 13, 8 & 16
7.00 in	6 & 16, 9 & 17
7.50 in	7 & 16, 9 & 17
8.00 in	8 & 16, 9 & 17

For more information, see [Install the server into a two-post rack](#).

Mechanical specifications

Specification	Value
Dimensions	—
Height	87.95 mm (3.46 in) (2-U)
Depth	451.25 mm (17.77 in)
Width	50.80 mm (2.00 in)
Weight, approximate values	—
Left or right support bracket	0.66 kg (1.46 lb)
Rack support	—
Rack column width	76.20 mm (3.00 in) to 203.20 mm (8.00 in)
Mounting screws	—
Front/back bracket Torx screw	6-32, 0.50 in
Quantity	8

Installing the server into a two-post rack

Prerequisites

- The two-post rack support brackets are secured to the rack by eight screws fastened to the rack columns. There are no rack rails

supporting this server in a two-post rack. Get help to lift and stabilize the server during rack installation. **At least two people must install the server into the rack:** One person to support the server weight, and the other to slide the server into the rack.

- Before you perform this procedure, review the:
 - [Space and airflow requirements](#)
 - [Rack warnings and cautions](#)
 - [Server warnings and cautions](#)
 - [Two-post rack mounting options](#)
- A fully populated server is heavy. Hewlett Packard Enterprise recommends removing the external chassis components before installing the server into a rack.
- For first-time installation in a square-hole rack, the following items are required:
 - Standard cage nuts (included in the two-post rack support kit)
 - Cage nut insertion tool
- Before you perform this procedure, make sure that you have the following items available:
 - T-20 Torx screwdriver
 - Torque screwdriver with T-25 Torx bit
 - [Rack enablement option kit](#)

About this task



IMPORTANT

To install the server in the rack, use the T-20 Torx screws and cage nuts that are included in the two-post rack support kit. These screws are designed to support the weight of this server.

Procedure

Installing the two-post rack support brackets

1. For first-time installation in a square-hole rack, install the cage nuts on the rack columns. To install a cage nut, do the following:
 - a. Hook the bottom lip of the cage nut in the square perforation of the front rack column.
 - b. Insert the tip of the insertion tool through the perforation and hook the top lip of the cage nut.
 - c. Use the insertion tool to pull the cage nut through the hole until the top lip snaps into position.

When installed, the lips (flanges) on the cage nut must face the outside of the rack:



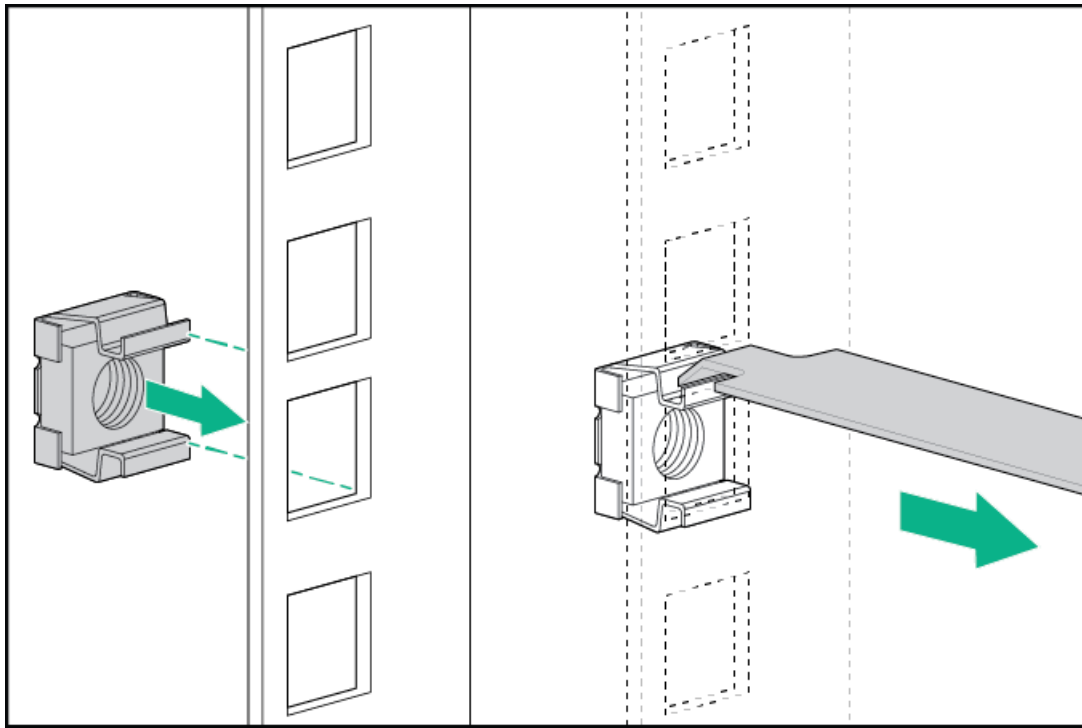

2. On the front and rear side of the rack columns, install the cage nuts into the top and bottom holes of a 2U space as shown in the following illustration.

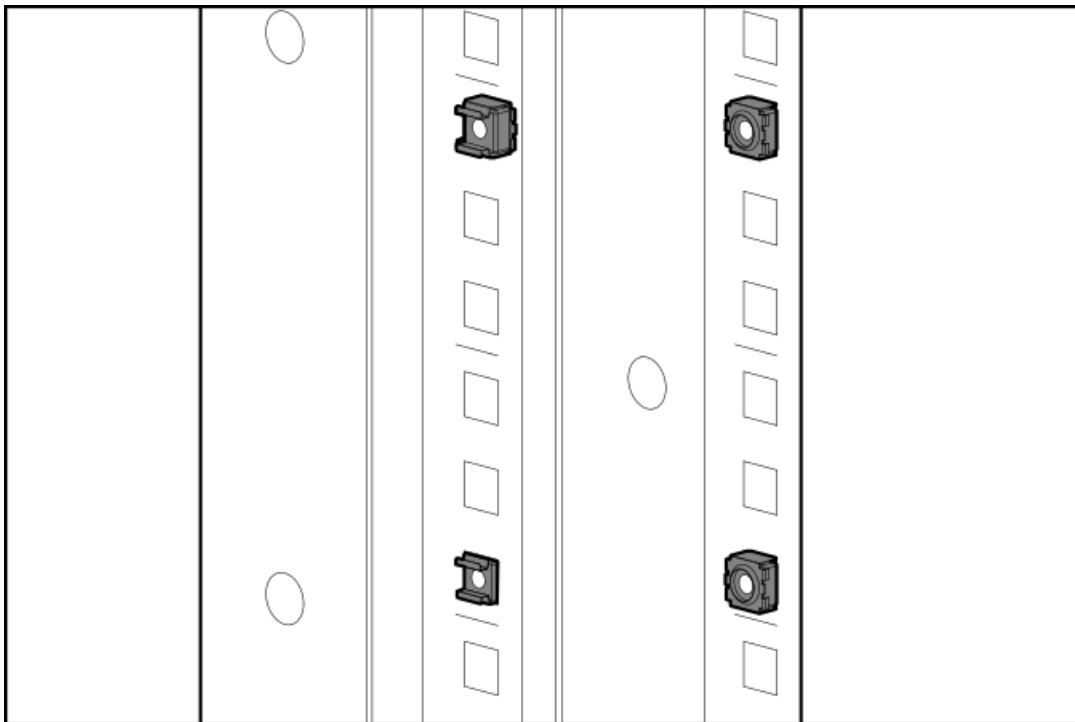

3. Take the right support bracket. Adjust the position of the back bracket:
 - a. Remove the two screws from the back bracket.
Retain the screws. The screws will be used to secure the back bracket.
 - b. Identify the rail depth markers on the support bracket.
 - c. Slide the back bracket according to your rail depth (3.00 in – 8.00 in).
If needed, slightly loosen the other two screws of the back bracket.



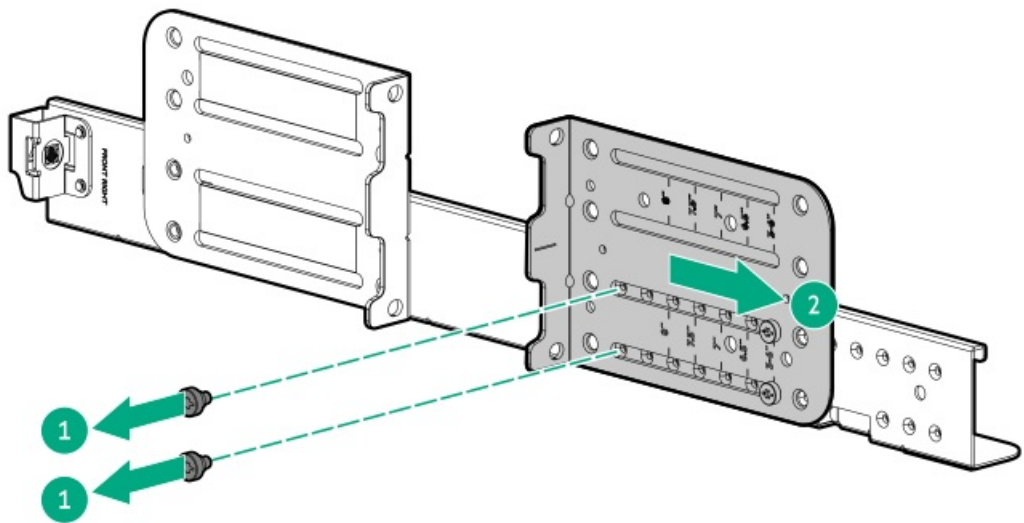

- 4. Secure the front bracket to the rack column:
 - a. Put the front bracket against the rack column.
 - b. Align the center line on the bracket with the rack unit marker on the rack column.
 - c. Install the screws.

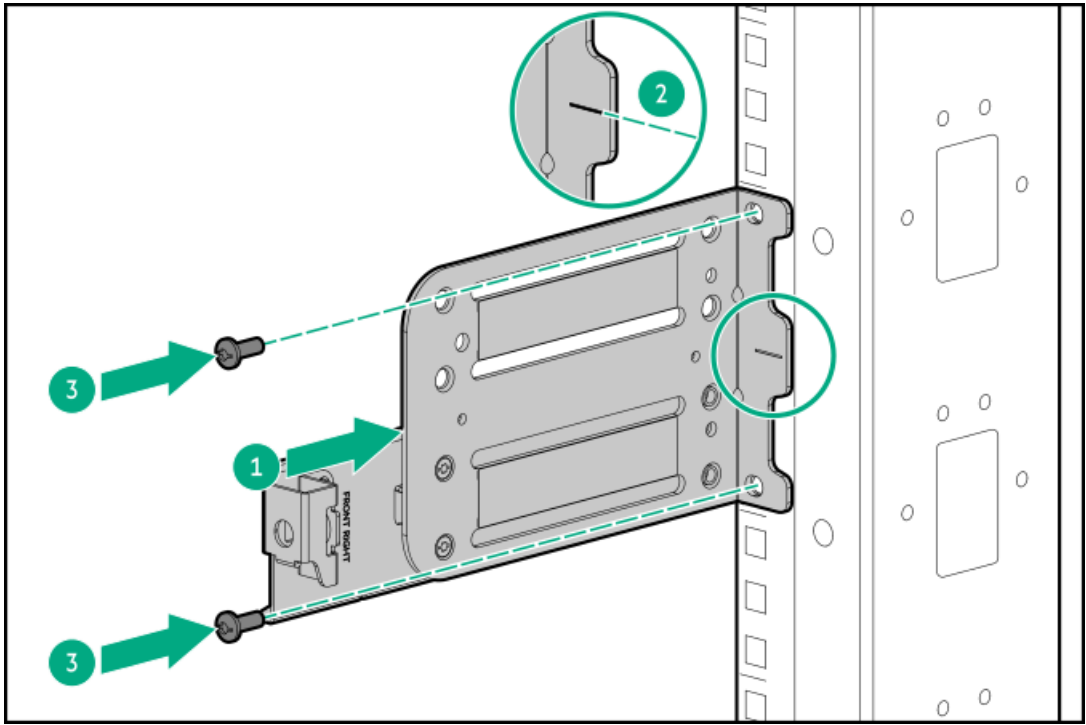

- 5. Secure the back bracket to the rack column.

The back bracket in the following illustration is at the factory default position (rail depth 3.00 in). Your rack may support different rail depths. Configure the back bracket accordingly.



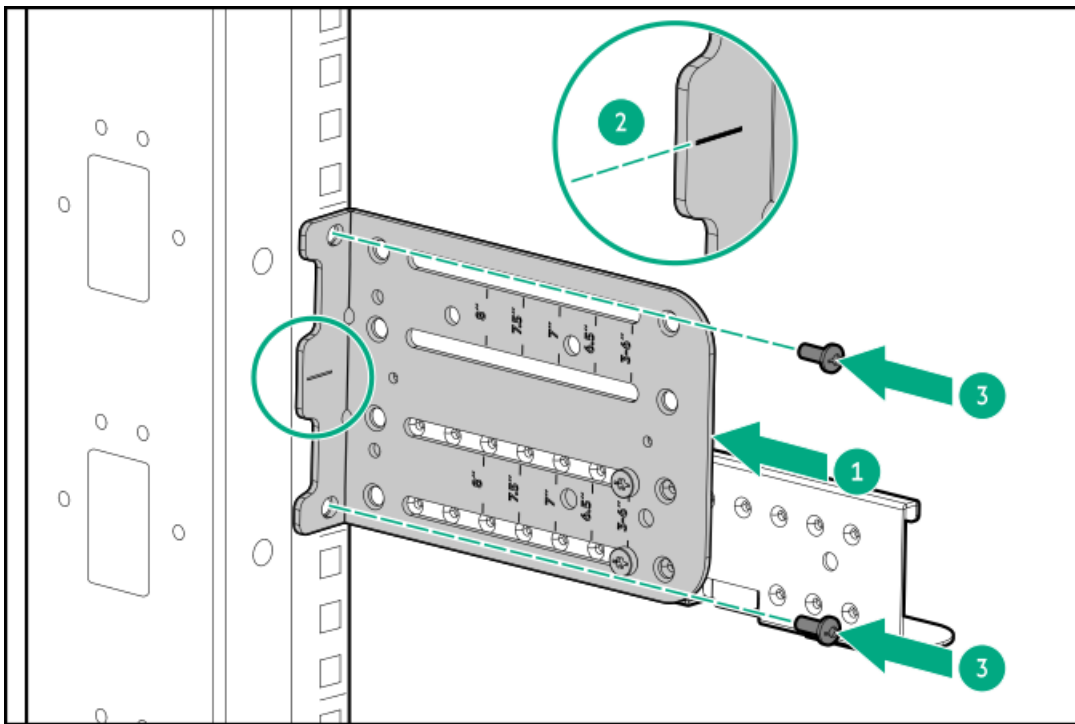

6. Install the screws on the back bracket, and ensure that the other two screws are tightened.

Your rack may support different rail depths. Use the screw positions that correspond to your rail depth.

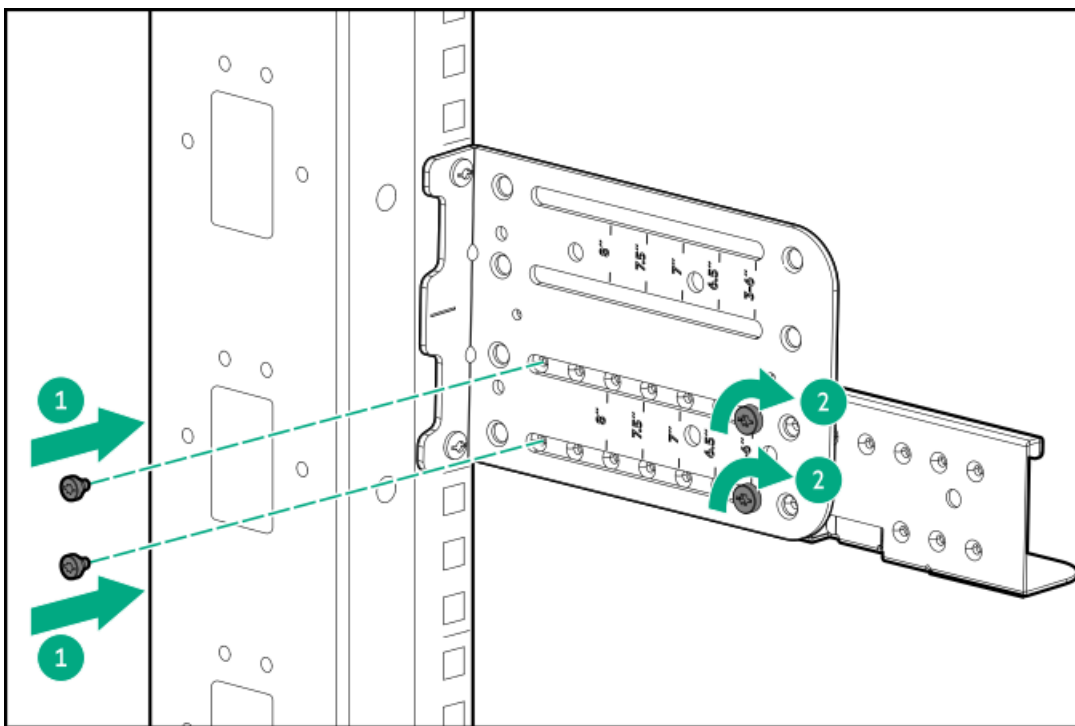

7. Repeat step 3 to 6 to install the left support bracket.



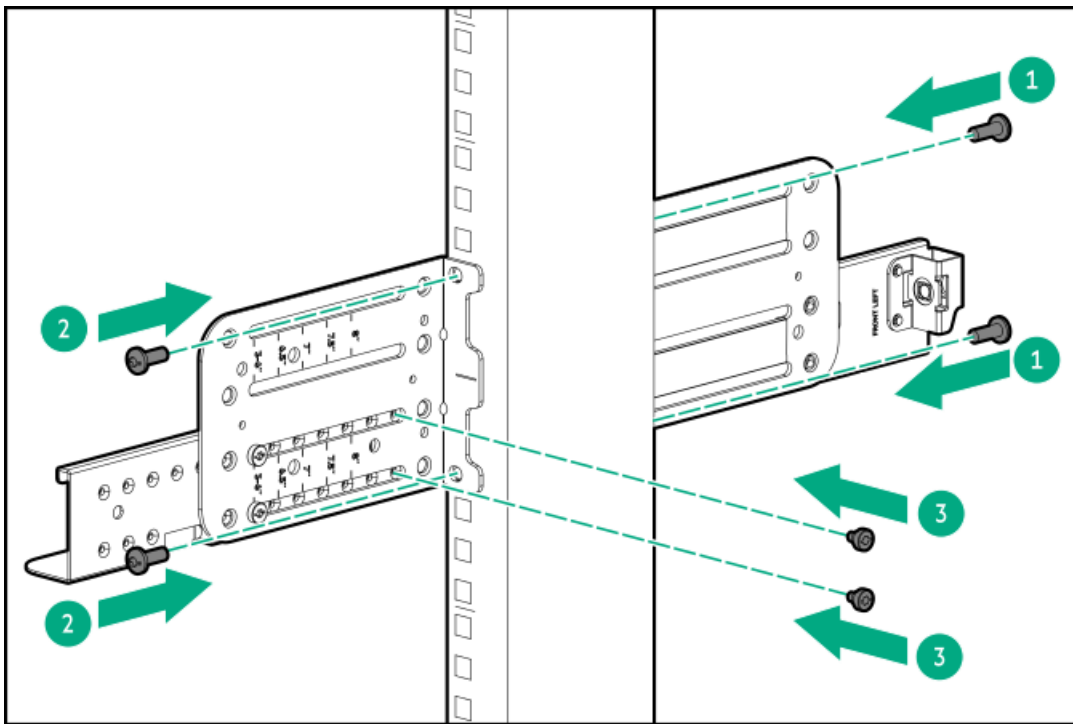

Installing the server into the two-post rack

8. Install the rack mount brackets on the server.

9. **At least two people must install the server into the rack.**

- a. First person: While supporting the weight of the server, insert the rack mount brackets into the two-post rack support brackets.
- b. Second person: Position the server inside the rack so that the ears of the rack mount brackets are flush against the two-post rack support brackets.

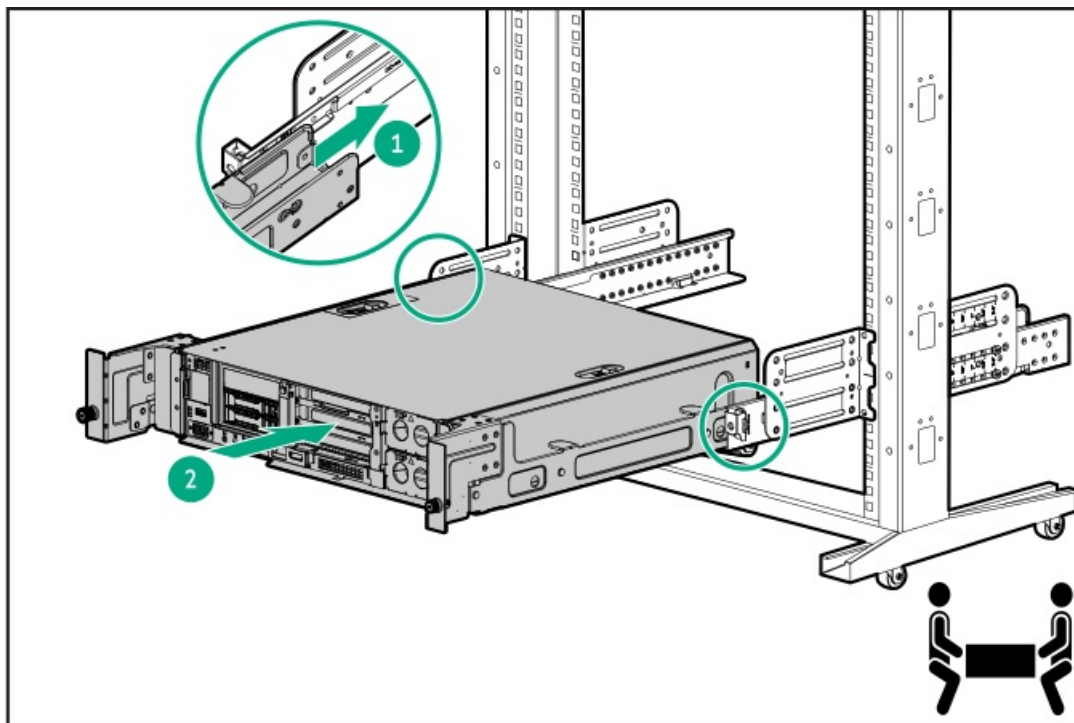

c. Fully tighten the ear screws until the ears are completely flush against the support brackets.

HPE recommends applying 2.37 N·m (21 lbf-in) of torque to securely tighten the screws.



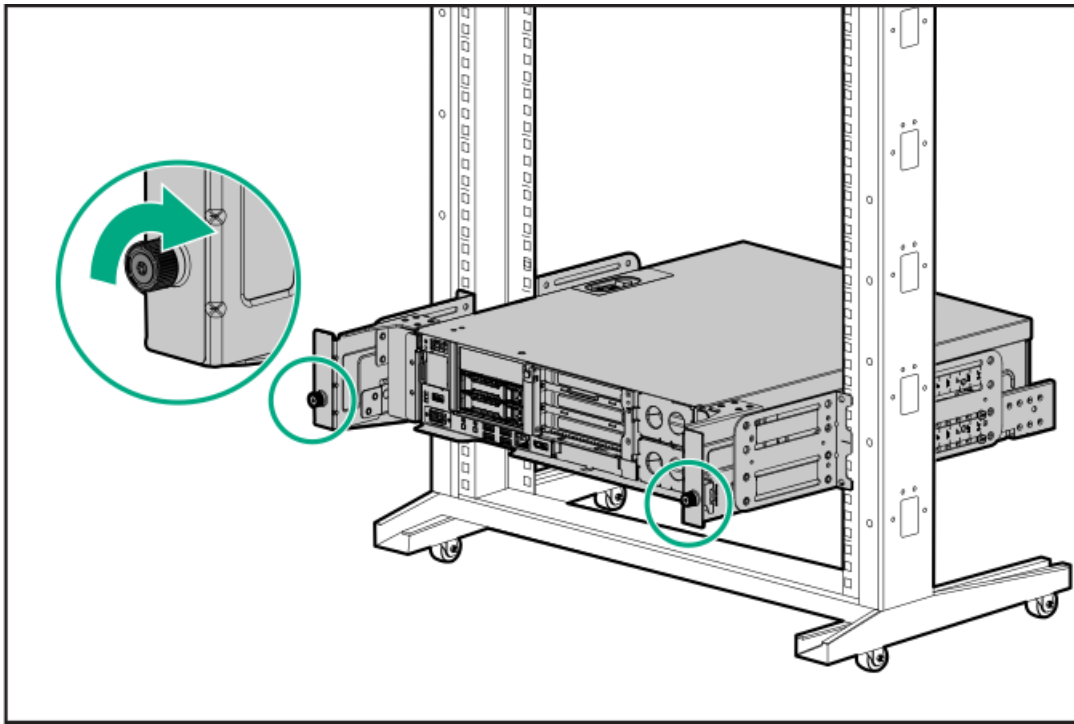

10. Inspect the server installation in the rack.
 - Make sure that the ears of the rack mount brackets are completely flush against the support brackets.
 - Make sure that there is no bending or tilting of the ears.
11. Route the server peripheral cables and power cords into the cable management channel on the rack mount to the front of the server.

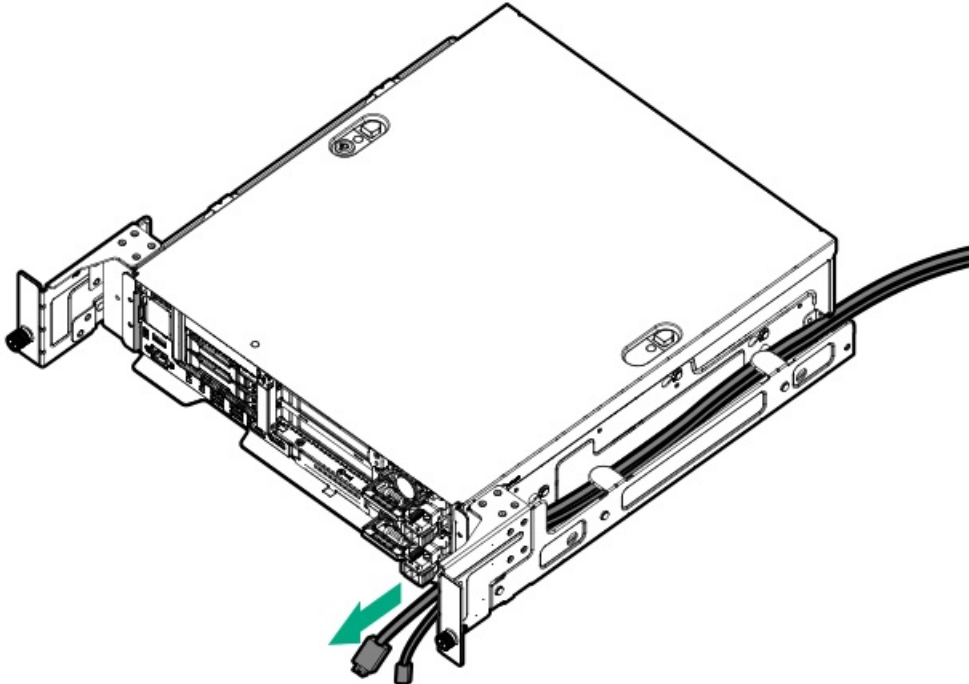

12. Connect all peripheral cables to the server.
13. Connect each power cord to the server.
14. Make sure that the server cables run under the cable management tabs on the rack mount.
15. Connect each power cord to the power source.



16. Employ industry best practices in routing and managing the peripheral cables and power cords.

17. If installing the front bezel, do the following:

- a. Route the server peripheral cables and power cords through the front bezel support brackets to the front panel.

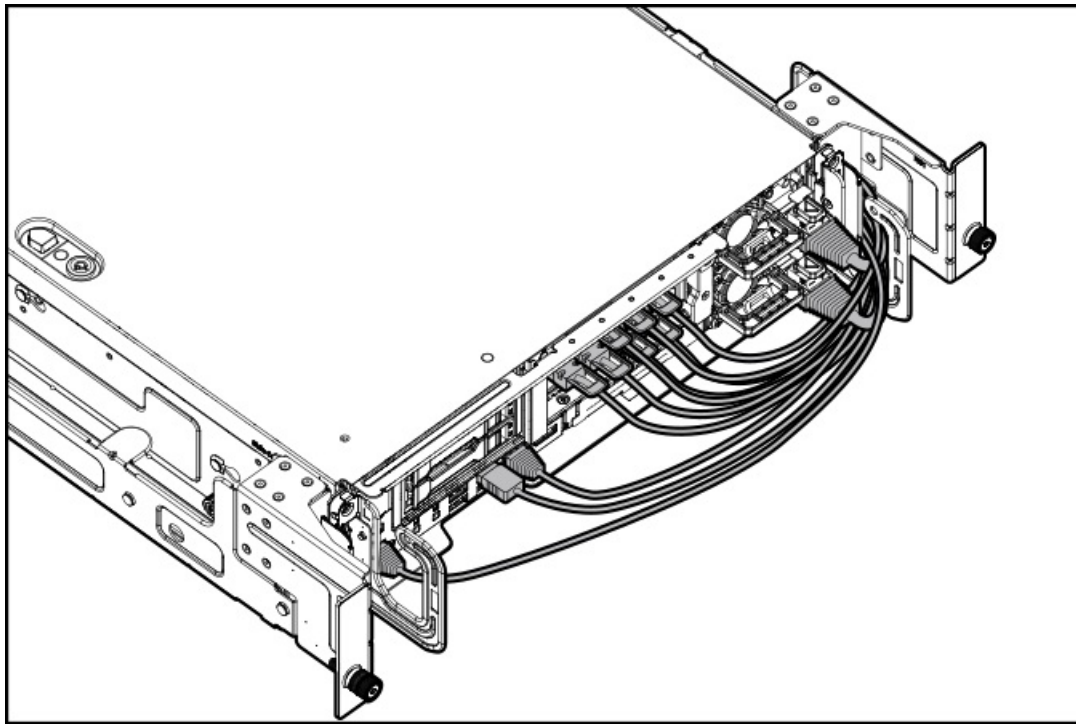

- b. Install the front bezel.

Results

The installation procedure is complete.

Wall mounting and desktop installation options

Use the wall mounting and desktop mounting option kit (P72006-B21) to support the following:

- Mounting the server on a brick/concrete wall or wooden wall *

The option kit does not support mounting on a dry wall.

- Mounting the server on a VESA mount. The option kit does not include a VESA mount.
- Installing the server on top of a desk

* The mounting surface must be capable of supporting three times the combined weight of the server and the mounting hardware (47.55 kg [104.82 lb]).

Subtopics

[Determine the location for the wall mount or desktop installation hardware](#)

[Wall mounting and desktop installation hardware](#)

[Installing the server in the wall mount](#)

[Installing the side covers for desktop installation](#)

Determine the location for the wall mount or desktop installation hardware

Determine the location for the wall mount or desktop installation hardware

Observe the following when determining the installation site:

- Wall mounting
 - Review the following:
 - [Space and airflow requirements](#)
 - [Server warnings and cautions](#)
 - Consider the effort required for installing and removing the server from the wall mount for servicing, as well as the front panel cabling connections.
 - The combined weight of server and the wall mount is 15.85 kg (34.94 lb). For safety, make sure that the mounting surface can support three times the combined weight (47.55 kg [104.82 lb]) before installation. If not, the mounting surface needs to be strengthened to meet this requirement.
- Desktop installation
 - Review the following:
 - [Space and airflow requirements](#)
 - [Server warnings and cautions](#)
 - Operate the server on a sturdy, flat, and level surface.
 - Do not stack servers on top of each other.

Wall mounting and desktop installation hardware

Screws or anchors are not included in the option kit to prevent misuse of the product. Note the following:

- Use appropriate fasteners and anchors for installation on a brick/concrete wall or wood wall.
- For installation on a wood wall, anchors are not required.
- Consult a qualified professional installer about the appropriate length of the screws for your wall type.

Side covers

The left and right side covers can be linked by the connecting brackets and used as a wall mount. For more information, see [Side covers](#).

Desktop installation of the server is supported with the side covers installed. There are rubber pads on the side covers to keep the server stationary. For more information about side cover installation, see [Installing the side covers for desktop installation](#).



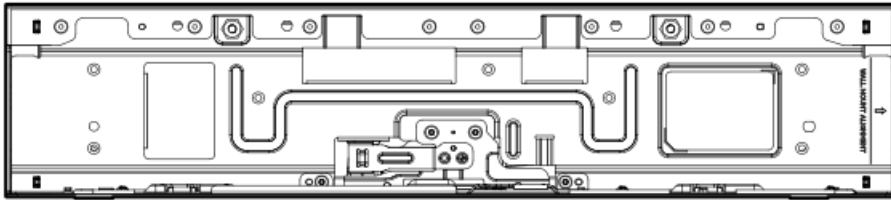
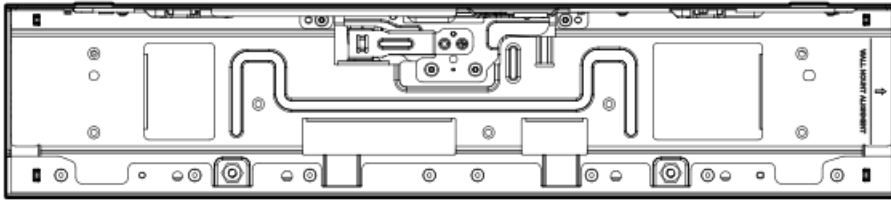

Wall mount connecting brackets

The connecting brackets are installed on the side covers to work as a wall mount. The brackets also support VESA mounts. For more information, see [Wall mount connecting brackets](#).

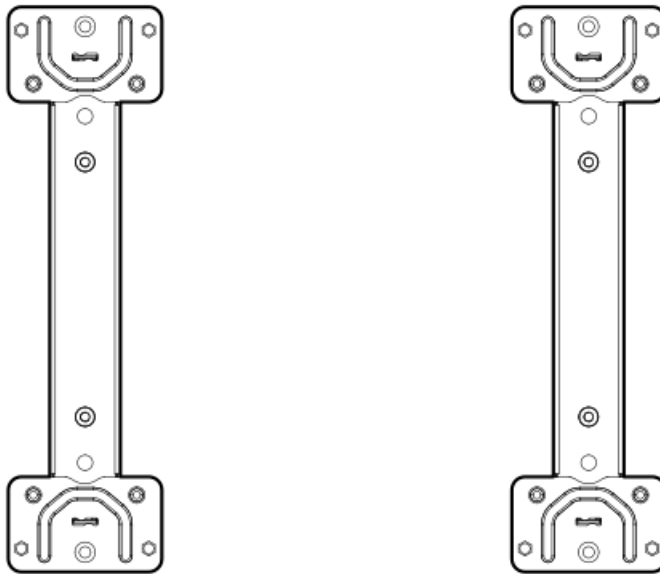

The wall mount can only be installed in a horizontal orientation, with the front of the server facing either left or right.



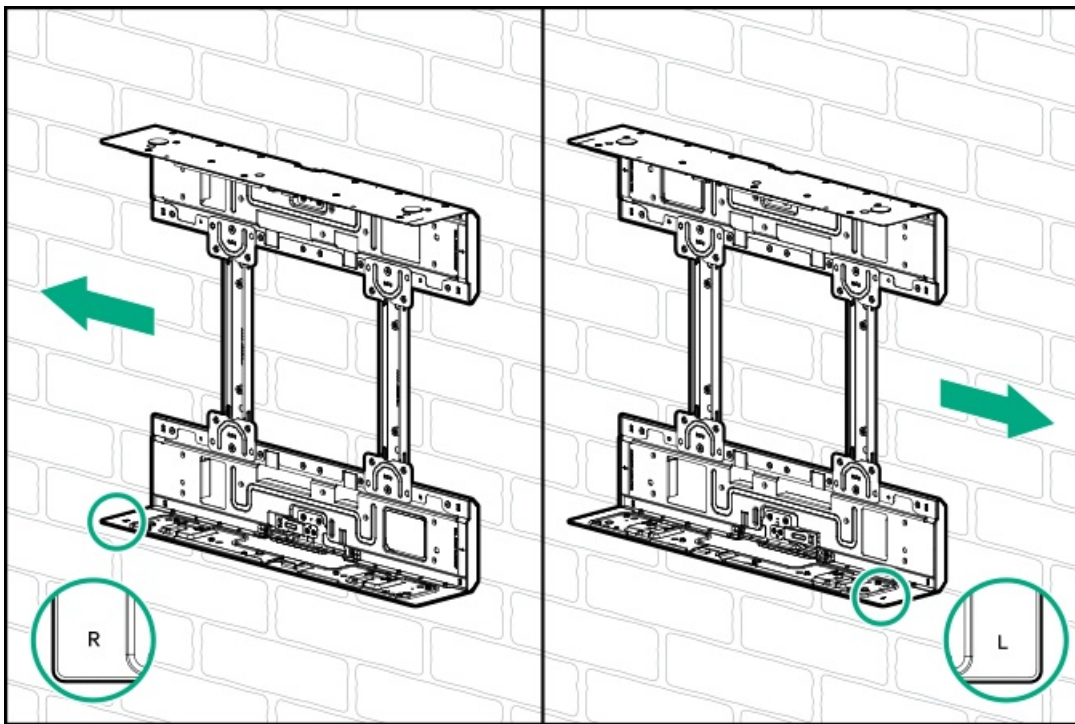

Subtopics

Wall mount connecting brackets

Side covers

Wall mount connecting brackets

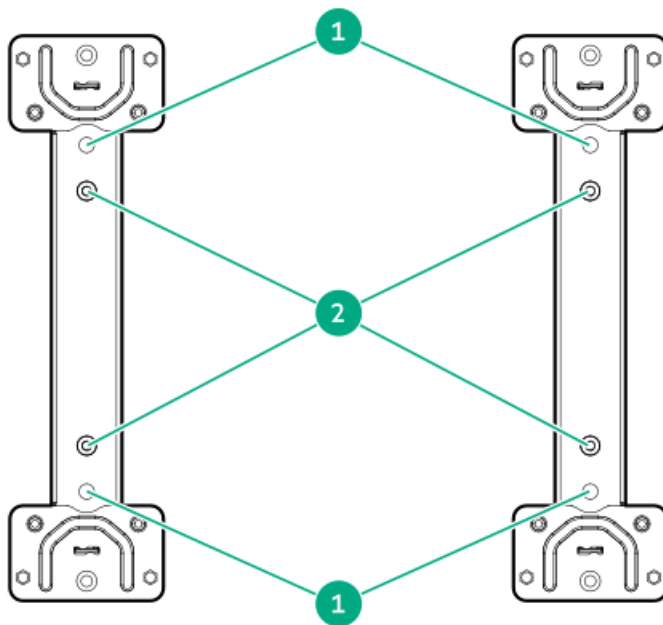

Item	Description
1	Wall mount holes
2	Standoffs for VESA mount, 200 mm x 100 mm (7.87 in x 3.94 in) *



* The wall mount option kit does not include a VESA mount or VESA mounting screws (recommended size: M4 x 10 mm). When the server is installed on a VESA mount, the front of the server can face either left or right.

Side covers

The side covers in the following diagram are in the wall mount configuration.

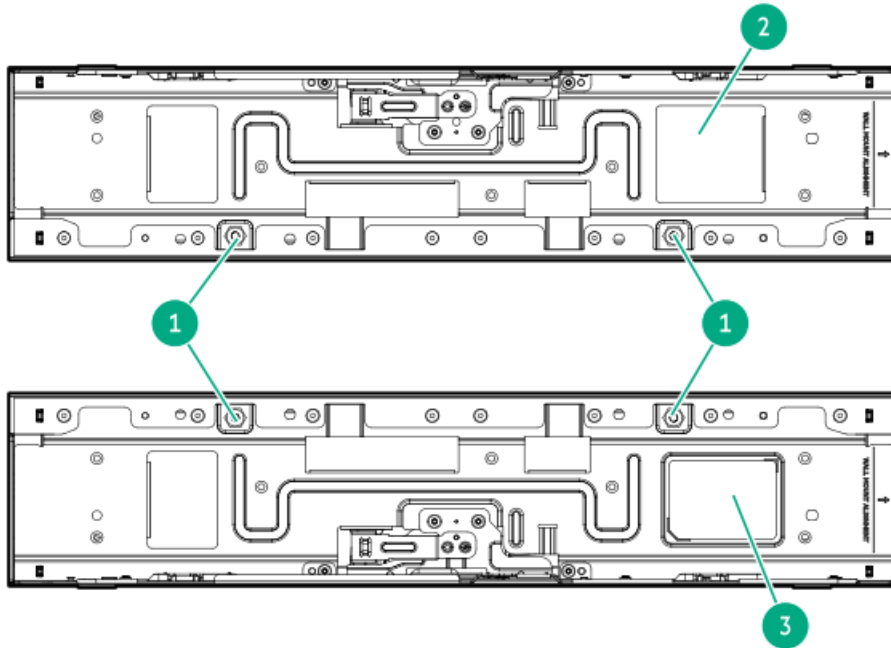

Item	Description
1	Screw holes for the wall mount bracket
2	Left side cover
3	Right side cover

Installing the server in the wall mount

Subtopics

[Configuring the side covers for wall mounting](#)

[Installing the connecting brackets](#)

[Installing the wall mount on the wall](#)

[Installing the server on the wall mount bracket](#)

Configuring the side covers for wall mounting

Prerequisites

- Review the [Wall mounting and desktop installation hardware](#).

- Before you perform this procedure, make sure that you have a T-10 Torx screwdriver available.

Procedure

1. If the side covers are attached to the server, do the following:
 - a. Unlock the side covers.
 - b. Slide the side covers toward the rear of the server, and then remove the side covers.

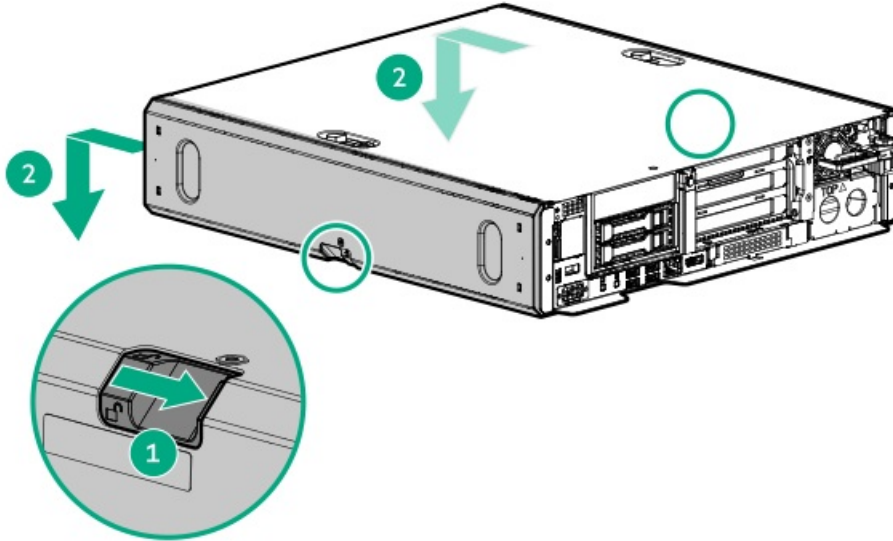

2. Remove the side cover brackets.
 - a. Loosen the screws on the bracket on both sides of the chassis.
 - b. Remove the brackets.

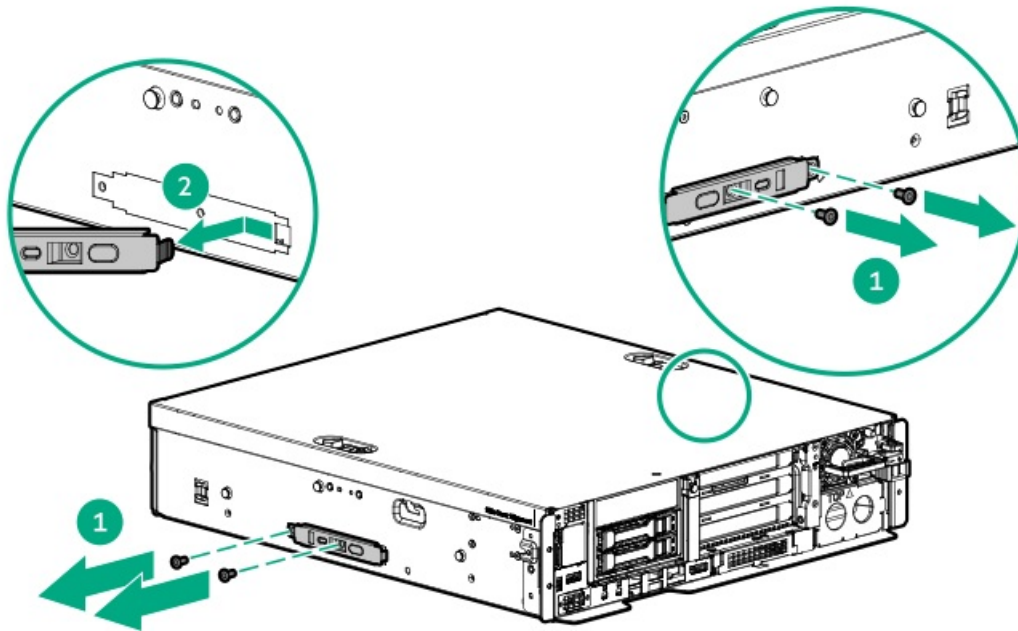

3. Remove the support bracket on the right side cover.
 - a. Remove the screws.
Retain the screws for later use.



b. Lift the support bracket and rotate it 90°.

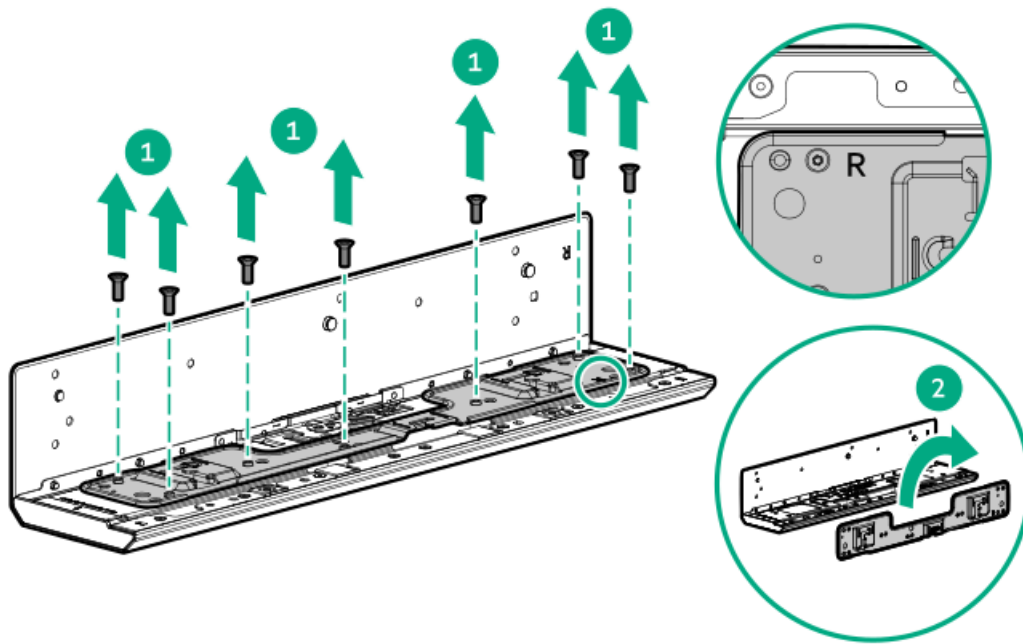

4. Install the support bracket back on the right side cover.

- a. Rotate the support bracket 180°.
- b. Attach the support bracket to the other side of the right side cover.
- c. Install the screws into the back side of the support bracket.

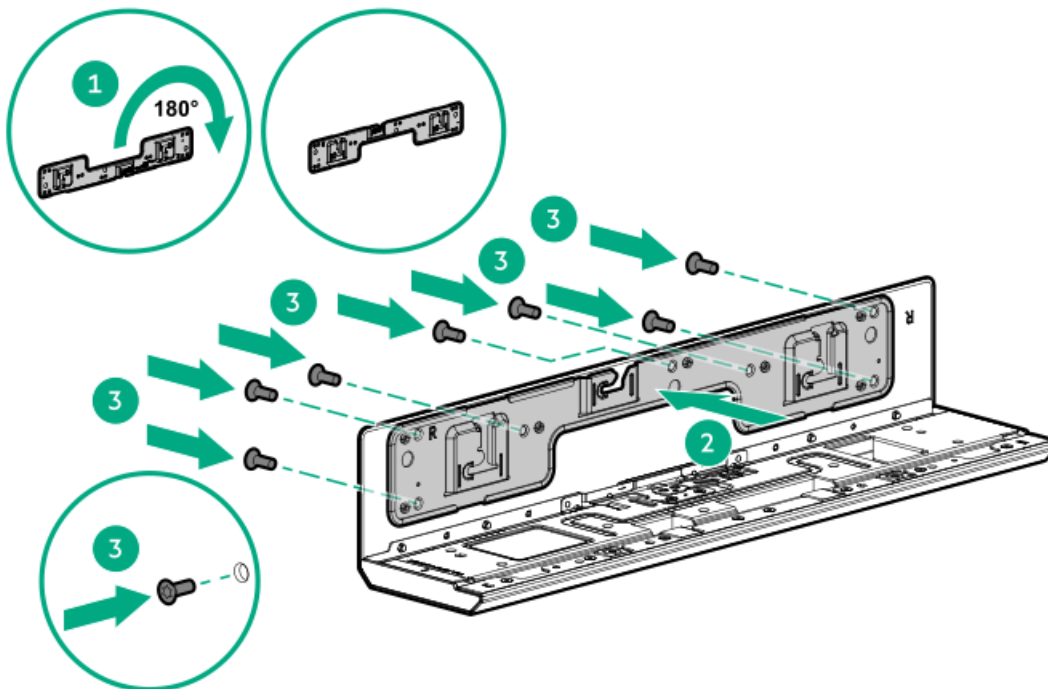

5. Repeat steps 3-4 to configure the left side cover for wall mounting.



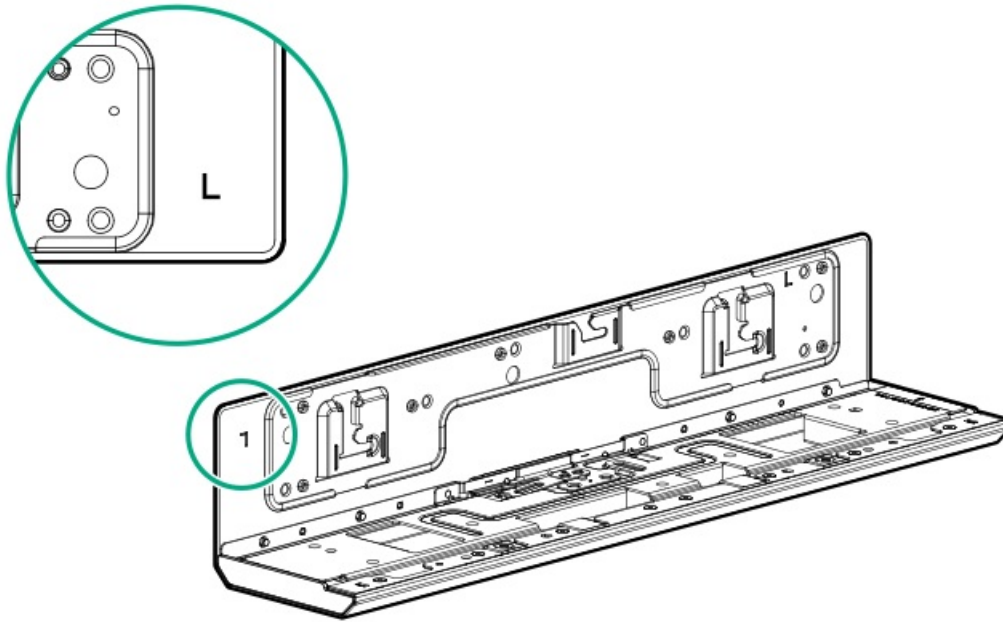

Results

The installation procedure is complete.

Installing the connecting brackets

Prerequisites

- Review the [Wall mounting and desktop installation hardware](#).
- The side covers are configured for wall mounting. For more information, see [Configuring the side covers for wall mounting](#).
- Before you perform this procedure, make sure that you have the following items available:
 - T-10 Torx screwdriver
 - Wall mount connecting bracket screws (M4 x 8.3 mm), included in the wall mount kit.

Procedure

1. Place the side covers on a flat and level surface, with the unpainted side facing up. Space the side covers about 18.50 cm (7.28 in) apart.
2. Attach the wall mount connecting brackets to the side covers.
 - a. Position the brackets on the side covers.
 - b. Install the screws.

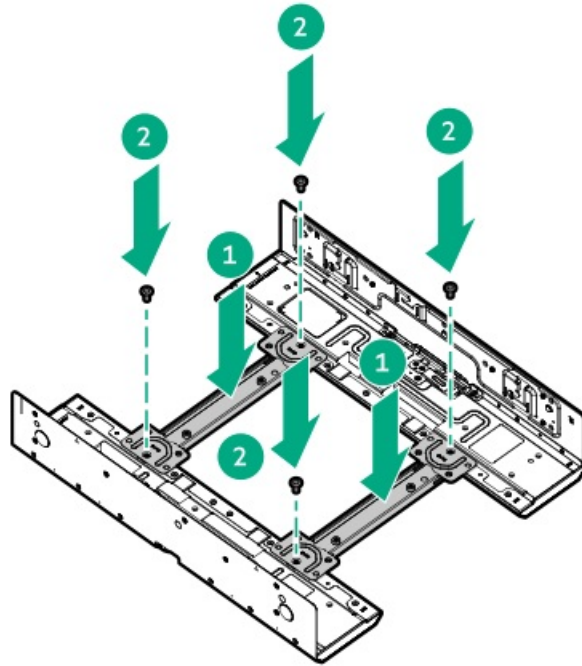

Results

The installation procedure is complete.

Installing the wall mount on the wall

Prerequisites

- Before you perform this procedure, review the following:
 - [Determine the location for the wall mount or desktop installation hardware](#)
 - [Wall mounting and desktop installation hardware](#)
- The wall mount connecting brackets are installed on the side covers. For more information, see [Installing the connecting brackets](#).
- Before you perform this procedure, make sure that you have the following items available:
 - Wall mount label (included in the wall mount kit)
 - For concrete / brick wall installation:
 - #10 x 1.5 inch (38.10 mm) self-tapping screws
 - Screw anchors for all materials
 - For wooden wall installation: #10 x 1.5 inch (38.10 mm) self-tapping screws
- Consult a qualified professional installer about the appropriate length of the screws for your wall type.

About this task

Screws or anchors are not included in the option kit to prevent misuse of the product. Use screws and/or anchors that are appropriate for your wall structure.

Procedure

1. Determine where the front of the server should face, either left or right.

2. Attach the wall mount label to the mounting surface.
3. Use a level to ensure that the mounting positions are perfectly straight.
4. To install on a brick / concrete wall:
 - a. Drill four pilot holes with a diameter of 7.920 mm (0.312 in) and a depth of at least 50.80 mm (2.00 in). To install anchors, the pilot holes need to be the same size and length as the anchors.
 - b. Remove the wall mount label.
 - c. Use a small wire brush to clean the pilot holes.
 - d. Use a hammer to install the anchors in the pilot holes.

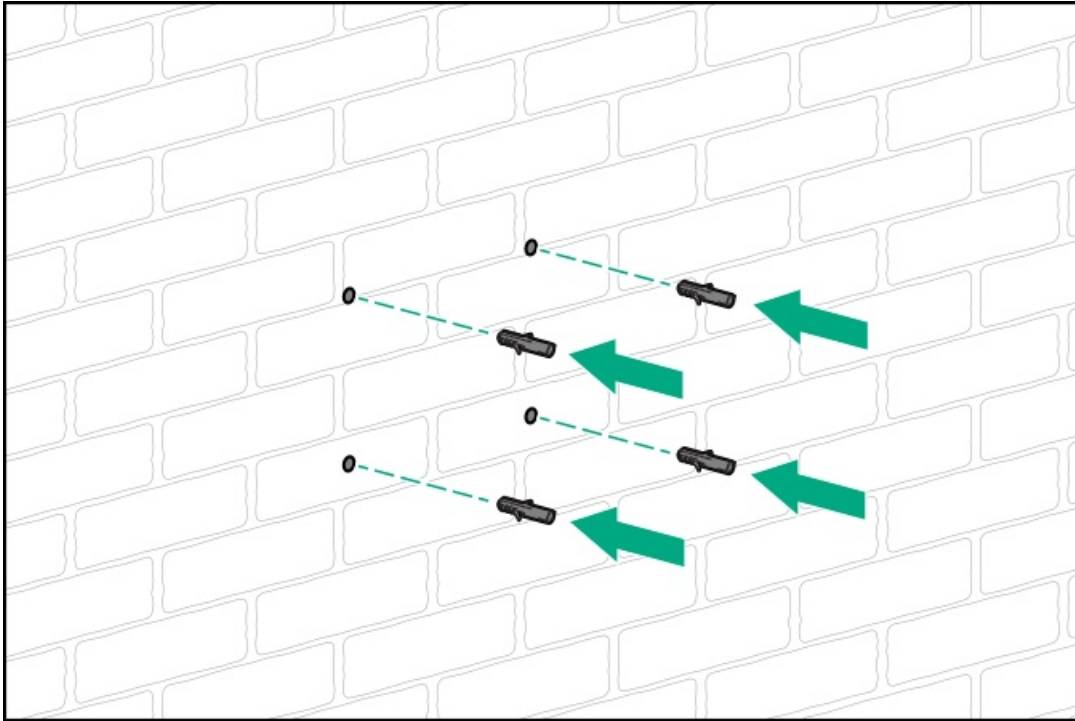

- e. Install the wall mount on the wall.

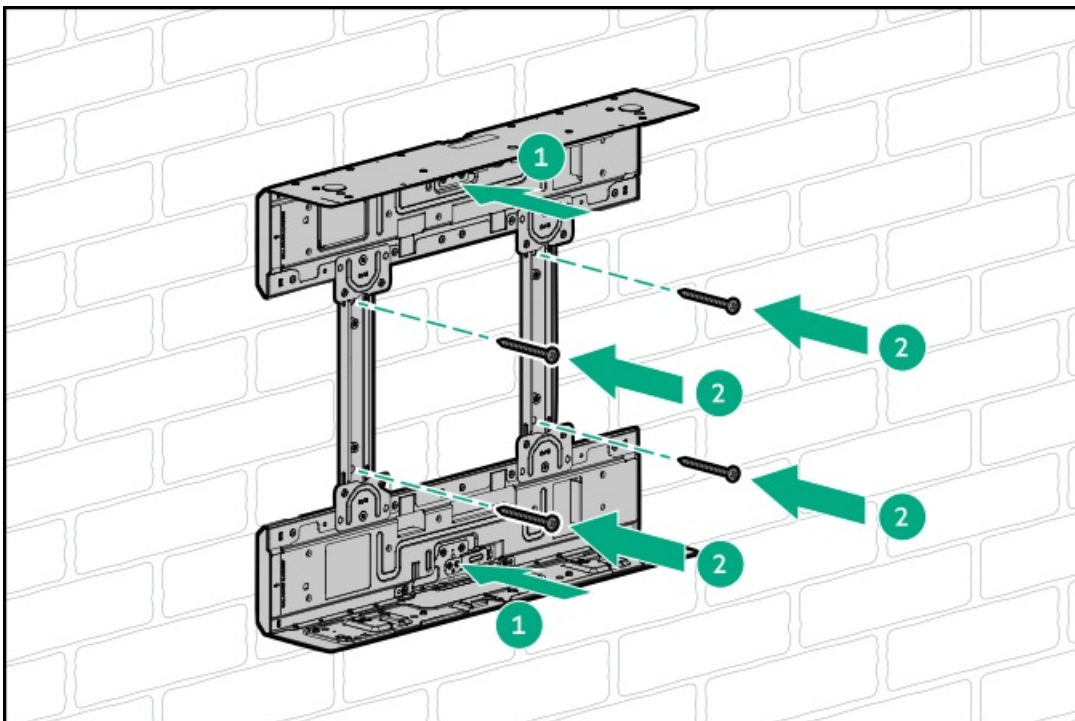

5. To install on a wooden wall:
 - a. Drill four pilot holes with a diameter of 7.920 mm (0.312 in) and a depth equal to the length of the screws.
 - b. Remove the wall mount label.
 - c. Use a small wire brush to clean the pilot holes. Anchors are not required.
 - d. Install the wall mount bracket on the wall.

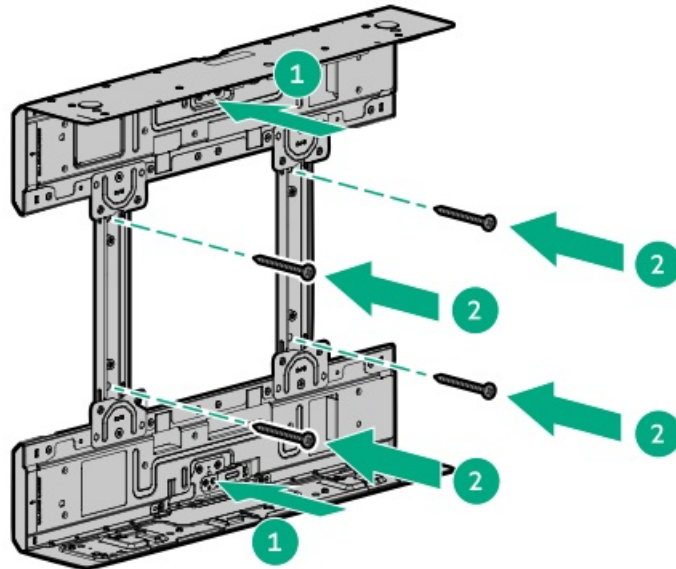

6. Completely tighten all four wall mount screws.

Results

The installation procedure is complete.

Installing the server on the wall mount bracket

Prerequisites

The wall mount is installed on the wall. For more information, see [Installing the wall mount on the wall](#).

Procedure

1. Use the label on the wall mount to determine which direction the front of the server should face.



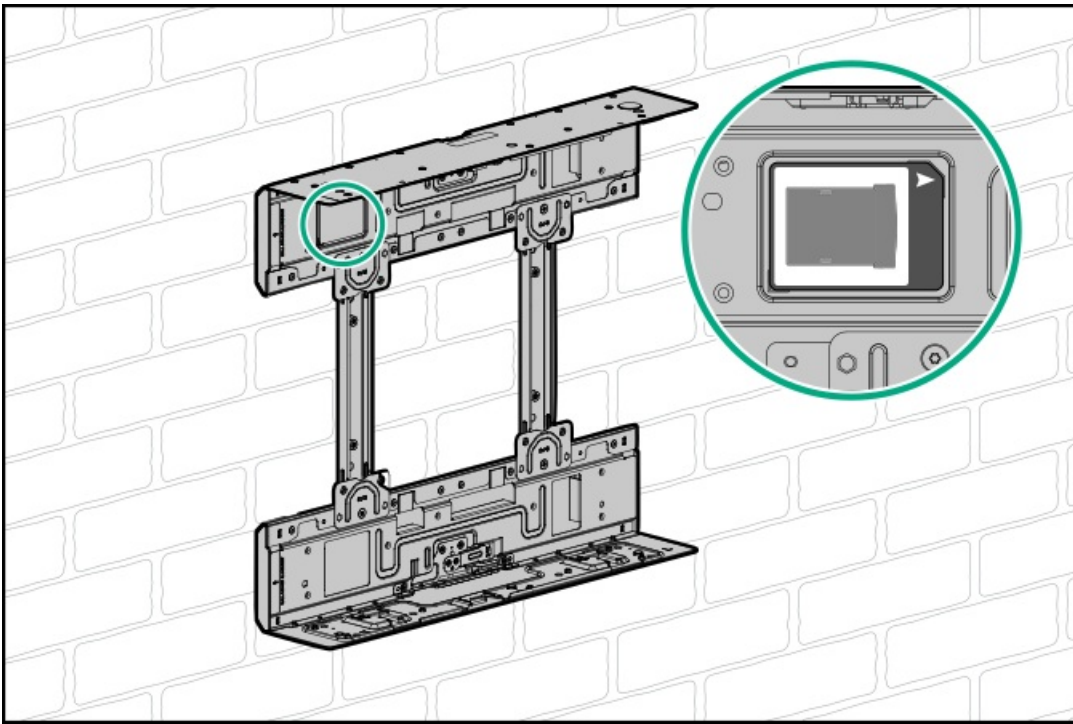

2. With the server front facing the direction in step 1, attach the server to the wall mount:

- a. Align the left edge of the server to the guiding line on the wall mount, and the right edge of the wall mount to the guiding line on the server. Slide the server into the wall mount.
- b. Slide the server toward the rear panel to lock it into place on the wall mount.

A click sound indicates the wall mount is properly engaged.

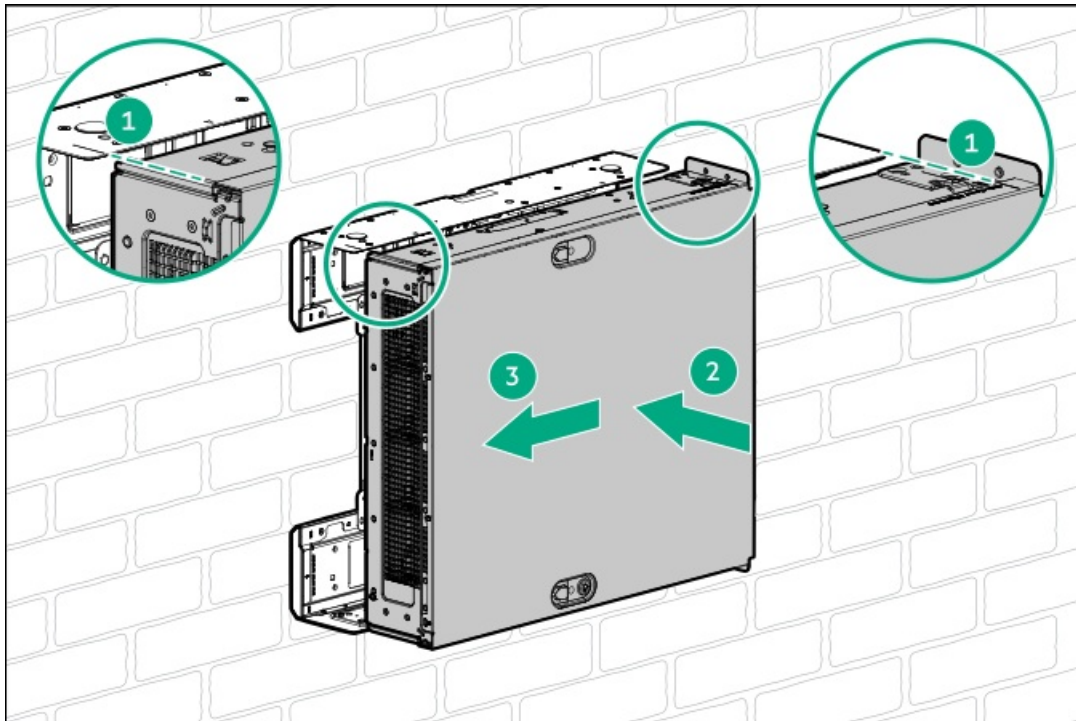

3. Push the latches on the side covers to lock the server in the wall mount.

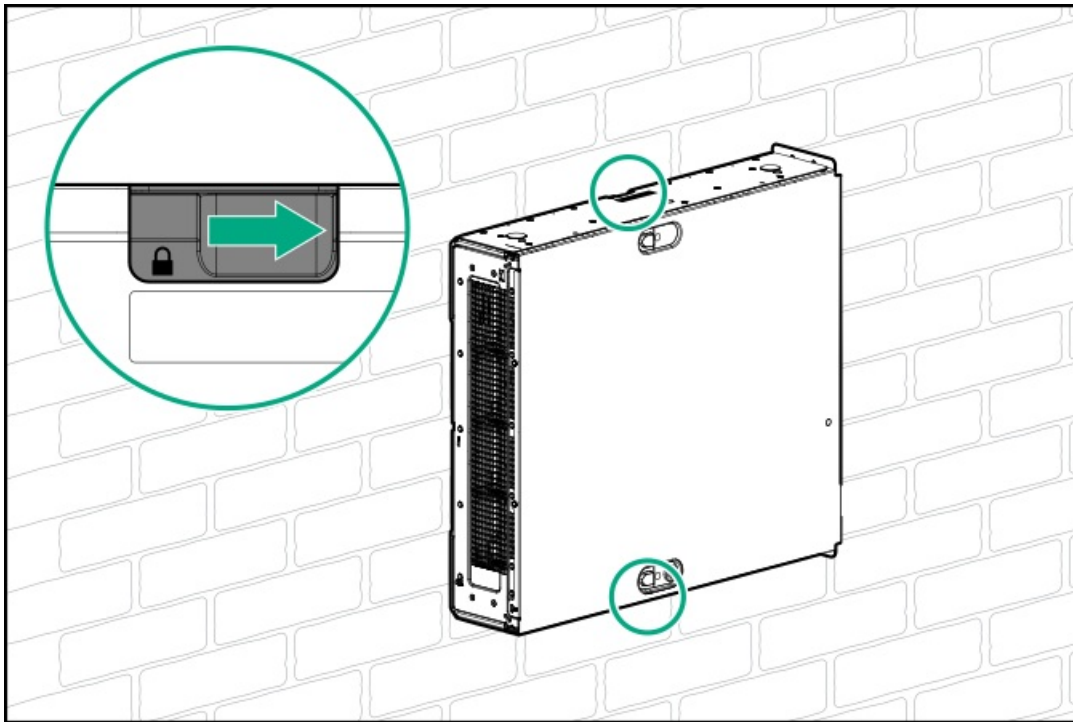

Results

The installation procedure is complete.

Installing the side covers for desktop installation

Prerequisites

- Review the following:
 - [Determine the location for the wall mount or desktop installation hardware](#)
 - [Wall mounting and desktop installation hardware](#)
- Identify the left and right side covers. For more information, see [Side covers](#).
- Before you perform this procedure, make sure that you have a T-10 Torx screwdriver available.

Procedure

1. If installed, [remove the front bezel](#).
2. [Power down the server](#).
3. Remove all power:
 - a. Disconnect each power cord from the power source.
 - b. Disconnect each power cord from the server.
4. Disconnect all peripheral cables from the server.
5. Place the server on a flat, level work surface.
6. Install the side cover brackets on the chassis:
 - a. Insert the tip of the bracket into the opening on both sides of the chassis. Align the screw holes of the bracket to the holes on the chassis.



- b. Install the screws.

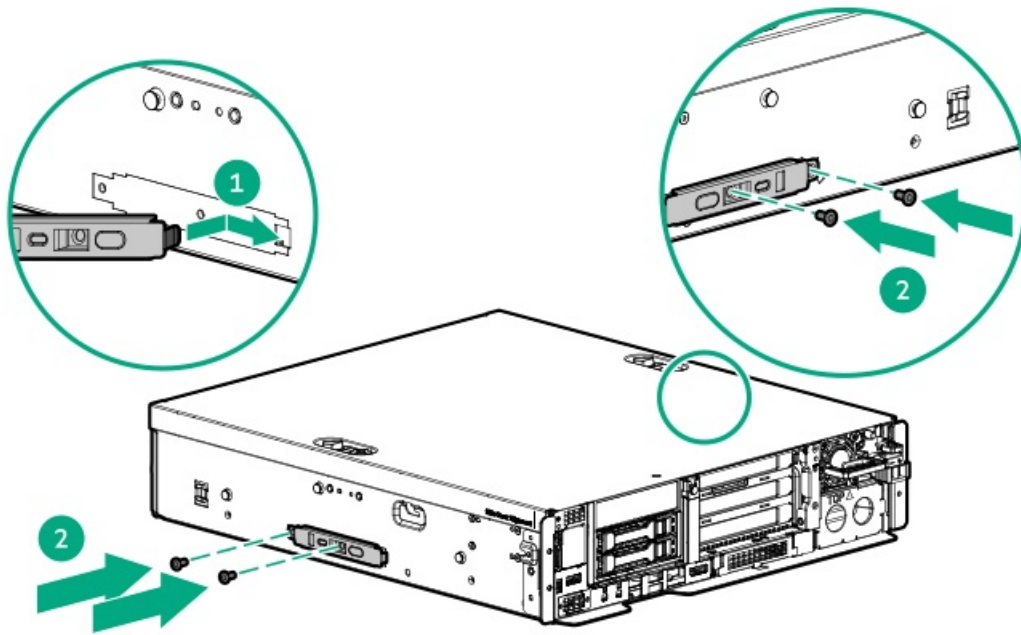

7.  CAUTION

To reduce the risk of personal injury or equipment damage, be sure to hold the server with two hands while the server is in a vertical orientation.

Position the server in a vertical orientation with the left side of the chassis facing up.

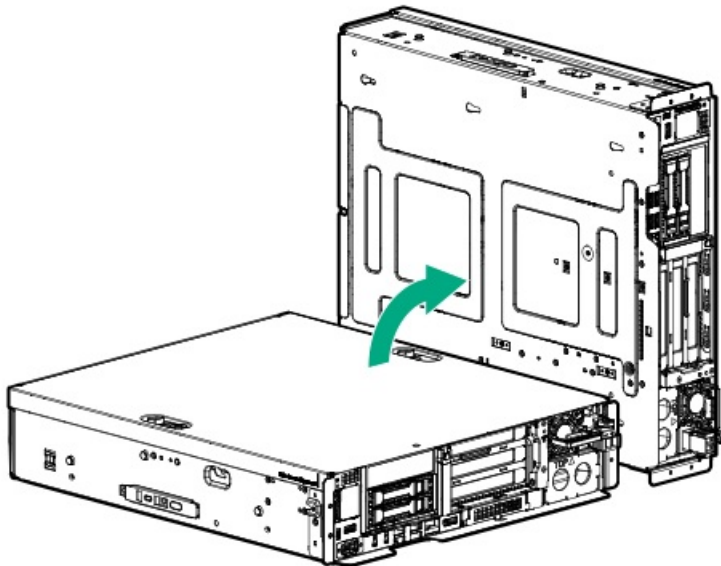

8. Install the left side cover:

- Align the front edge of the side cover to the guiding line on the chassis.
- Slide the side cover toward the front panel to engage with the spools on the chassis.
- Lock the side cover.



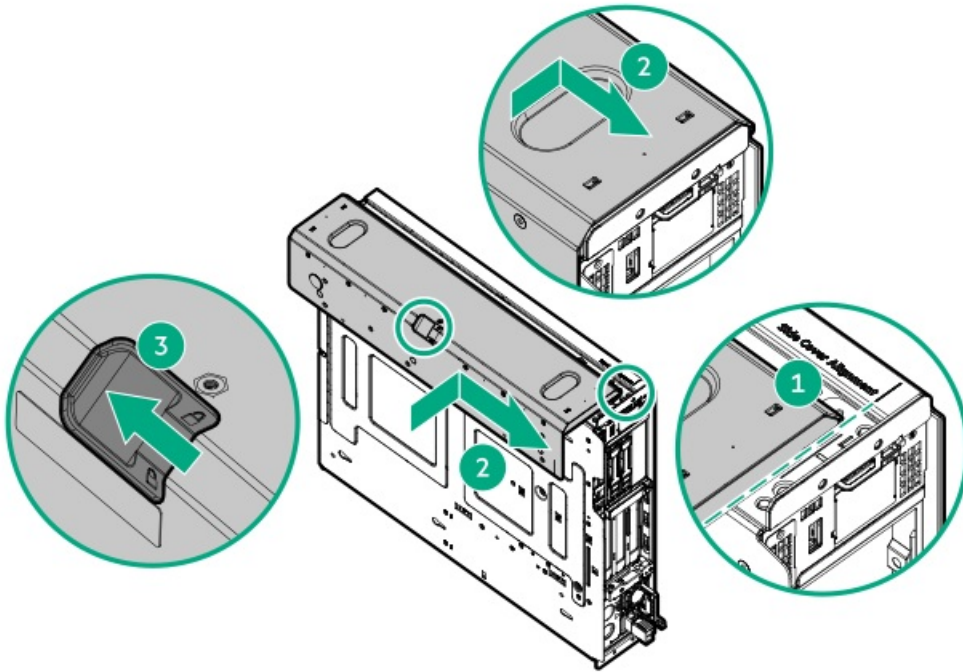

9.  **CAUTION**

To reduce the risk of personal injury or equipment damage, be sure to hold the server with two hands while the server is in a vertical orientation.

Use two hands to rotate the server 180°.

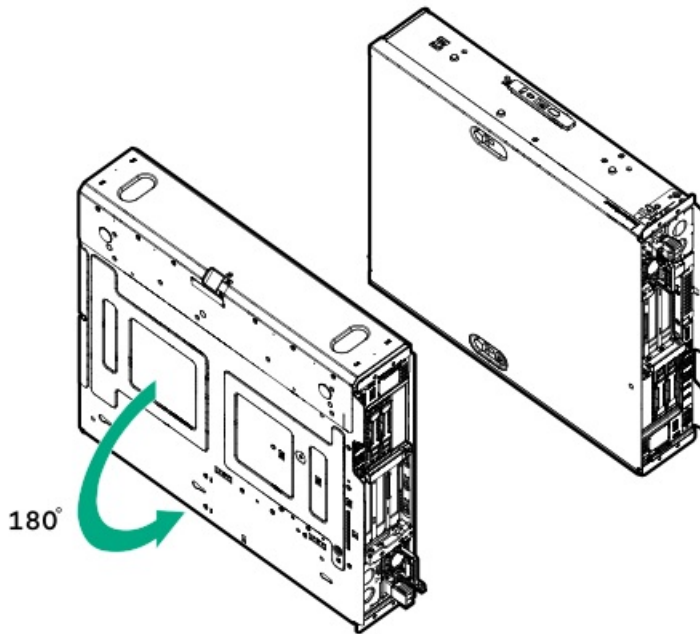

10. Repeat step 8 to install the right side cover.

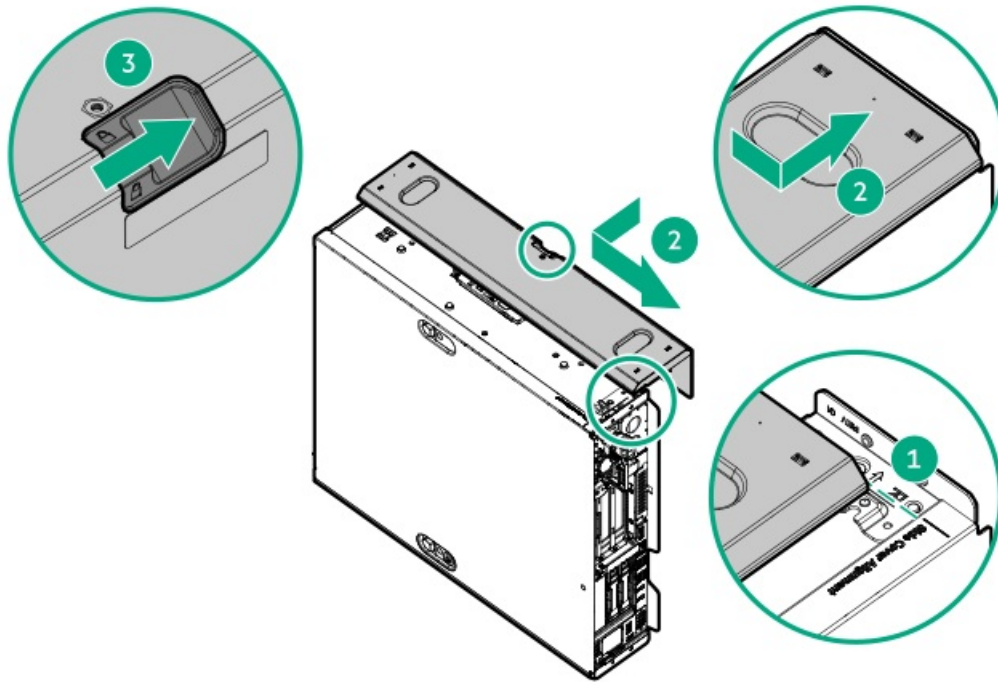

11. Use two hands to position the server back in the horizontal orientation.

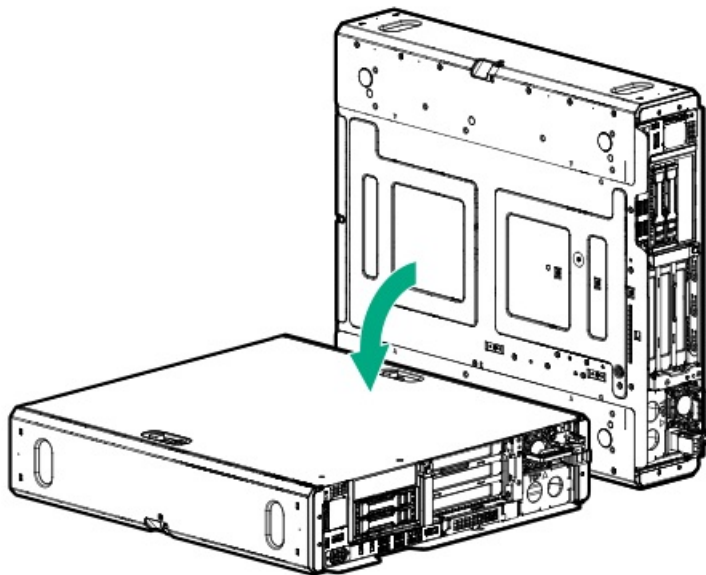

Results

The installation procedure is complete.

Installing the front bezel option

Prerequisites

The brackets of the FIO front bezel (P72582-B21) are installed on the server.

Procedure



1. Route the peripheral cables and power cords through the left or right bezel cabling bracket and to the front panel.
2. Connect all peripheral cables to the server.
3. Connect each power cord to the server.
4. Connect each power cord to the power source.
5. Install the front bezel:
 - a. Slide the front bezel to engage with the front bezel brackets.
 - b. Press and hold the latches on the bezel.
 - c. While holding the latches, push the bezel to make sure it is fully engaged with the brackets.

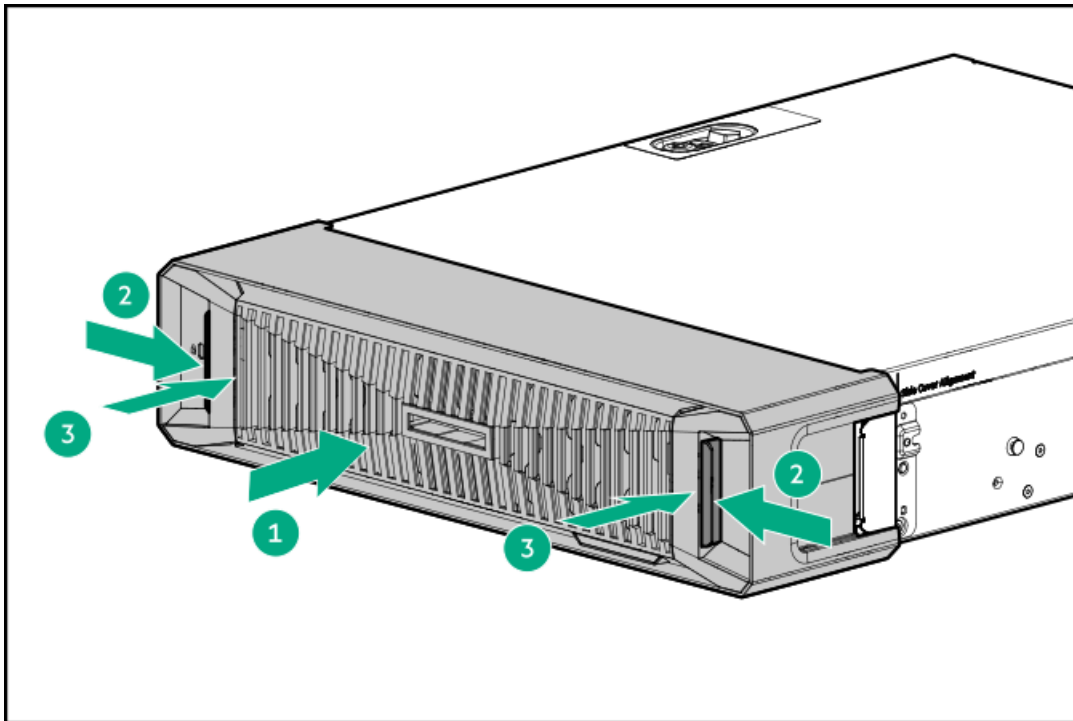

6. (Optional) Install the Kensington security lock.

For more information, see the lock documentation.

Results

The installation procedure is complete.

Front bezel filter replacement kit option

Use the front bezel filter replacement kit (P72583-B21) to replace the dirty air filter located inside the FIO front bezel .



IMPORTANT

Front bezel air filter service reminders:

- HPE recommends changing the filter at least every three to six months.
- Upon installation of the FIO front bezel, a filter change timer is triggered in iLO.
- To remind users of the service life of the filter, iLO will send notification messages at 85 days and 90 days of operation. The iLO notification will indicate that the filter is about to or has reached its maximum limit for high particulate environments. After reaching this limit, it is advised that the air filter be inspected and replaced if necessary to ensure optimal performance.
- When replacing the front bezel filter, follow the procedure in the server maintenance guide:
<https://www.hpe.com/info/dl145gen11-msg>



NOTE

When resetting iLO to the factory default settings, the iLO filter change timer setting is erased and the timer is disabled. For more information on the timer reset procedures, see the server maintenance guide:
<https://www.hpe.com/info/dl145gen11-msg>

For more information on the FIO front bezel and filter kit, see the product QuickSpecs on the HPE ProLiant DL145 Gen11 Server website:

<https://www.hpe.com/info/quickspecs>

* The front bezel is only available as a factory installable option (P72582-B21).

Subtopics

[Front bezel filter maintenance guidelines](#)

Front bezel filter maintenance guidelines

To ensure optimal filter performance, observe the following guidelines for the storage, service, and replacement of the front bezel filters.

Storage

- Avoid storing the air filters in a high temperature and high humidity environment. The optimal storage location is one that is cool, dry, and sheltered from direct sunlight.
- Do not expose the filters to cleaning solvents and sulfates, for example, cleaning agents and exhaust. The chemicals can cause filter degradation. The decrease in filter service life depends on the degree of deviation from the optimal storage and operating environment.
- Purchase economic quantities of the filter and keep enough inventories lasting just a few months. Storing filters for several months or years at a time is not recommended.

Service and replacement

- Regularly inspect the bezel filter. Replace the filter if it looks clogged or is too dirty. The filter is single-use and should be replaced when necessary. Cleaning the filter can risk undermining the integrity of the filter media, and is not recommended.
- HPE recommends changing the filter at least every three to six months.
- For telecommunication operators and service providers, the governing NEBS standard requires that equipment air filters be replaced following the guideline and recommendation of the manufacturer.

NEBS GR-63-CORE, environmental criteria of network equipment, includes a requirement that "Equipment fan filters shall be single use and not the types that require cleaning."

Power supply options

Depending on the installed options and the regional location where the server was purchased, the server can be configured with one of the supported [power supplies](#).

Subtopics

[Hot-plug power supply calculations](#)

[Power supply warnings and cautions](#)

[DC power supply warnings and cautions](#)

[DC power supply wire colors](#)

[Installing an AC power supply](#)

[Installing a DC power supply](#)

[Connecting a DC power cable to a DC power source](#)

Hot-plug power supply calculations

For hot-plug power supply specifications and calculators to determine electrical and heat loading for the server, see the Hewlett Packard Enterprise Power Advisor website (<https://www.hpe.com/info/poweradvisor/online>).

Power supply warnings and cautions



WARNING

To reduce the risk of electric shock or damage to the equipment:

- Do not disable the power cord grounding plug. The grounding plug is an important safety feature.
- Plug the power cord into a grounded (earthed) electrical outlet that is easily accessible at all times.
- Unplug the power cord from the power supply to disconnect power to the equipment.
- Do not route the power cord where it can be walked on or pinched by items placed against it. Pay particular attention to the plug, electrical outlet, and the point where the cord extends from the server.



WARNING

To reduce the risk of injury from electric shock hazards, do not open power supplies. Refer all maintenance, upgrades, and servicing to qualified personnel.



CAUTION

Mixing different types of power supplies in the same server might:

- Limit or disable some power supply features including support for power redundancy.
- Cause the system to become unstable and might shut down.

To ensure access to all available features, all power supplies in the same server should have the same output and efficiency ratings. Verify that all power supplies have the same part number and label color.

DC power supply warnings and cautions



WARNING

To reduce the risk of electric shock, be sure that the cable grounding kit is properly installed and connected to a suitable protective earth terminal before connecting the power source to the rack.



CAUTION

This equipment is designed to permit the connection of the earthed conductor of the DC supply circuit to the earthing conductor at the equipment. If this connection is made, all the following must be met:

- This equipment must be connected directly to the DC supply system earthing electrode conductor or to a bonding jumper from an earthing terminal bar or bus to which the DC supply system earthing electrode conductor is connected.
- This equipment must be located in the same immediate area (such as adjacent cabinets) as any other equipment that has a connection between the earthed conductor of the same DC supply circuit and the earthing conductor, and also the point of earthing of the DC system. The DC system must be earthed elsewhere.
- The DC supply source is to be located within the same premises as the equipment.
- Switching or disconnecting devices must not be in the earthed circuit conductor between the DC source and the point of connection of the earthing electrode conductor.

DC power supply wire colors

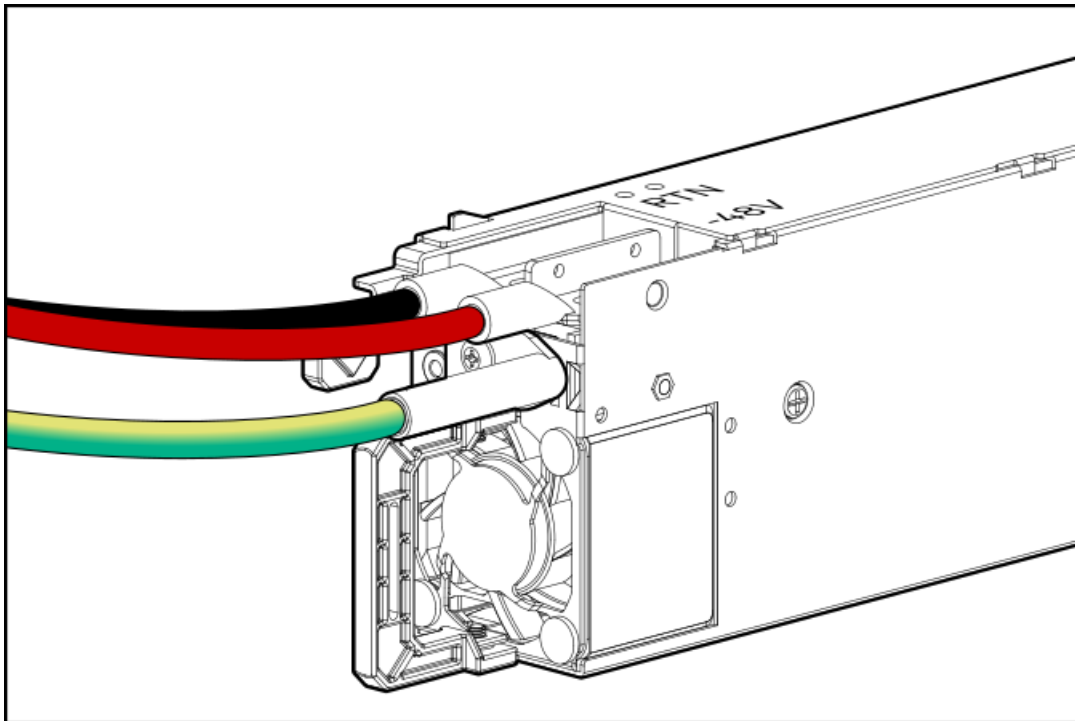

Wire color	Description	Wire slot
Red	Line wire	-48V
Black	Return wire	Return
Green + Yellow	Ground wire	Safety ground

Installing an AC power supply

Prerequisites

Before installing a power supply option, review the [Power supply warnings and cautions](#).

About this task



WARNING

To reduce the risk of personal injury from hot surfaces, allow the power supply, power supply blank, or dual slot power supply adapter to cool before touching it.



CAUTION

To prevent improper cooling and thermal damage, do not operate the server unless all bays are populated with either a component or a blank.

Procedure

1. Remove the power supply blank.

Retain the blank for future use.

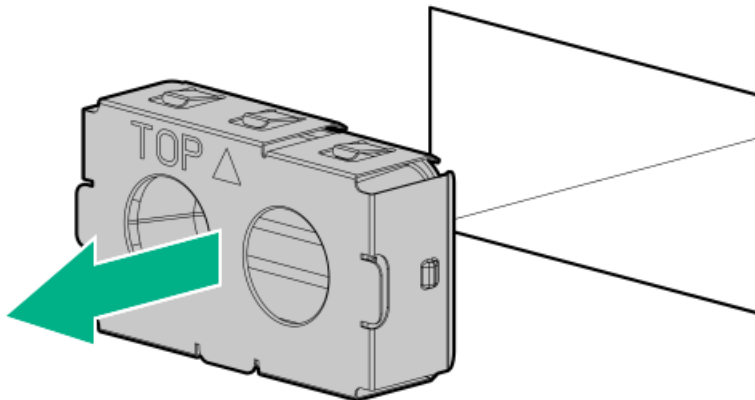

2. Install the power supply.

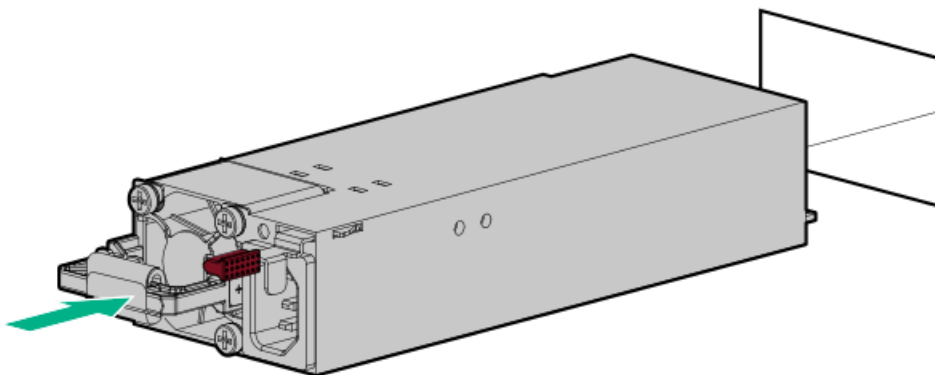

3. Connect the power cord to the power supply.
4. Secure the power cord.



CAUTION

Avoid tight bend radii to prevent damaging the internal wires of a power cord or a server cable. Never bend power cords and server cables tight enough to cause a crease in the sheathing.

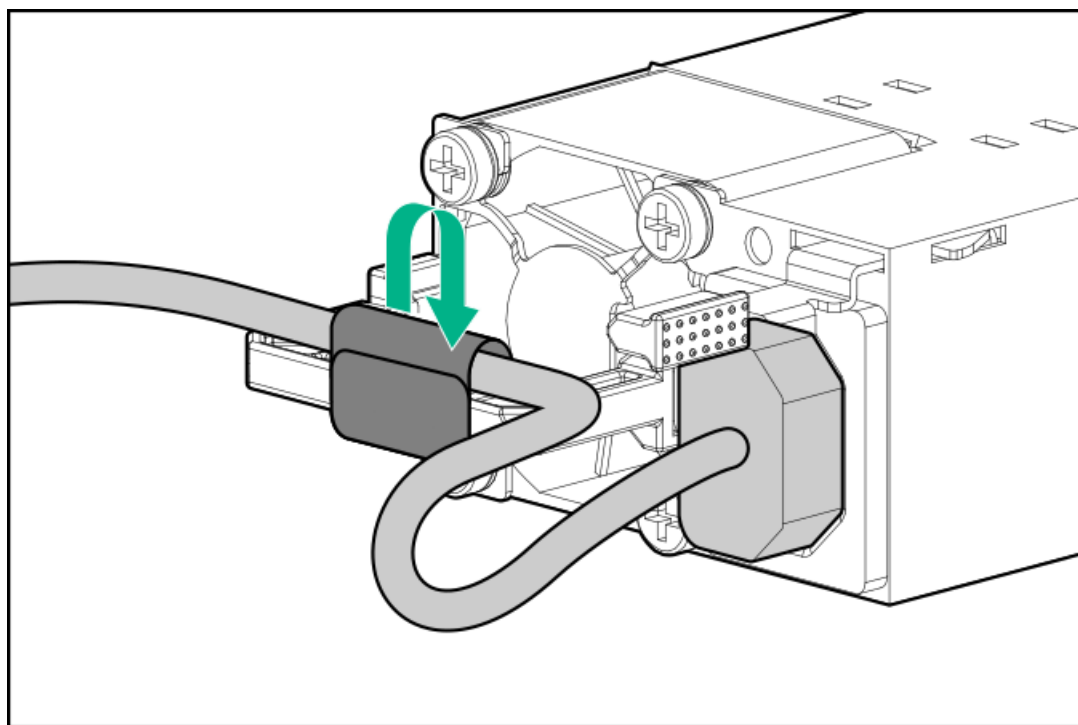

5. Connect the power cords:
 - a. Connect each power cord to the server.
 - b. Connect each power cord to the power source.
6. Make sure that the power supply LED is green.

Results

The installation procedure is complete.



Installing a DC power supply

Prerequisites

- Power cable requirement: The HPE 2.85 m, 48 VDC Power Cable Kit (Q0H80A) can be purchased from an authorized Hewlett Packard Enterprise reseller. If HPE power cable option is not utilized, appropriate cabling must be implemented to ensure product reliability. Suitable options include either solid conductors or stranded conductors that have ferrules installed on the ends. The power cord connection must be made in consultation with a licensed electrician and be compliant with local code.
- Before installing a power supply option, review the following:
 - [Power supply warnings and cautions](#)
 - [DC power supply warnings and cautions](#)
- Before you perform this procedure, make sure that you have the following items available:
 - Phillips No. 1 screwdriver
 - Crimping tool

About this task



WARNING

To reduce the risk of personal injury from hot surfaces, allow the power supply, power supply blank, or dual slot power supply adapter to cool before touching it.



CAUTION

To prevent improper cooling and thermal damage, do not operate the server unless all bays are populated with either a component or a blank.

Procedure

1. Remove the ring tongue.

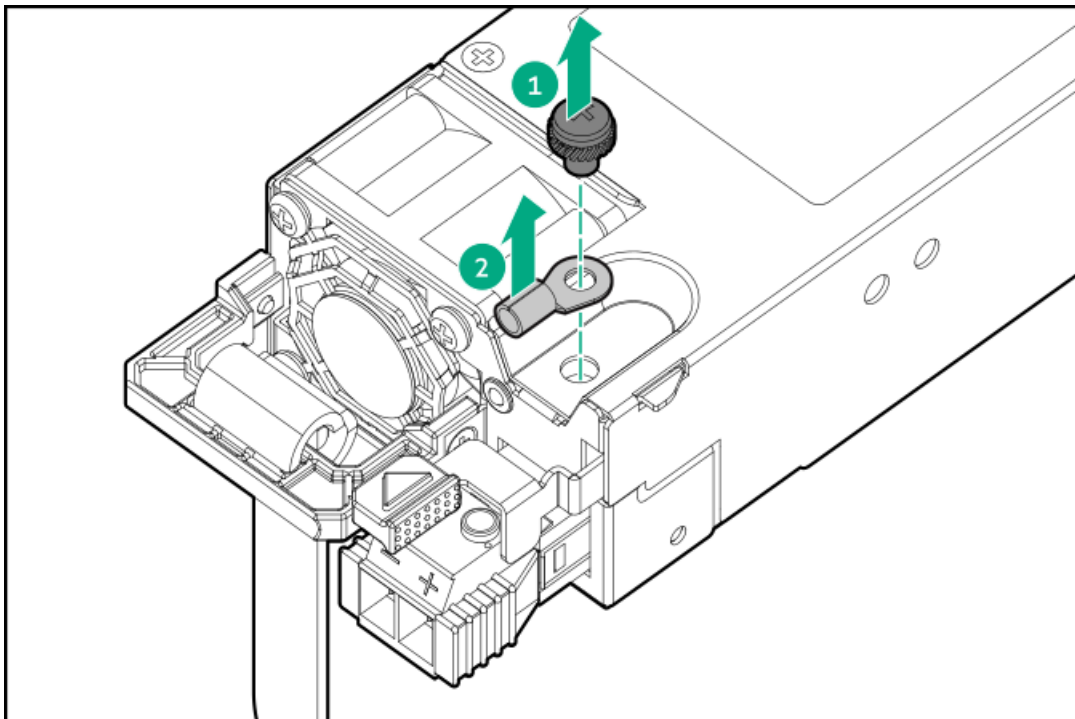

2. Crimp the ring tongue to the ground cable from the -48 V DC power source.

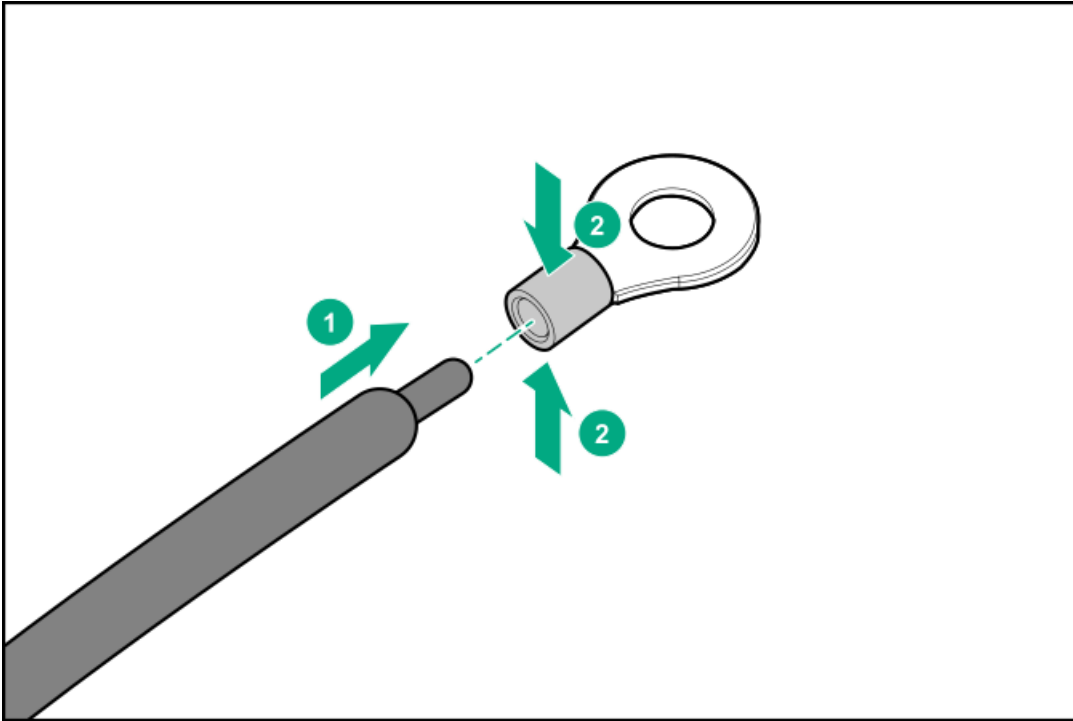

3. Remove the terminal block connector.

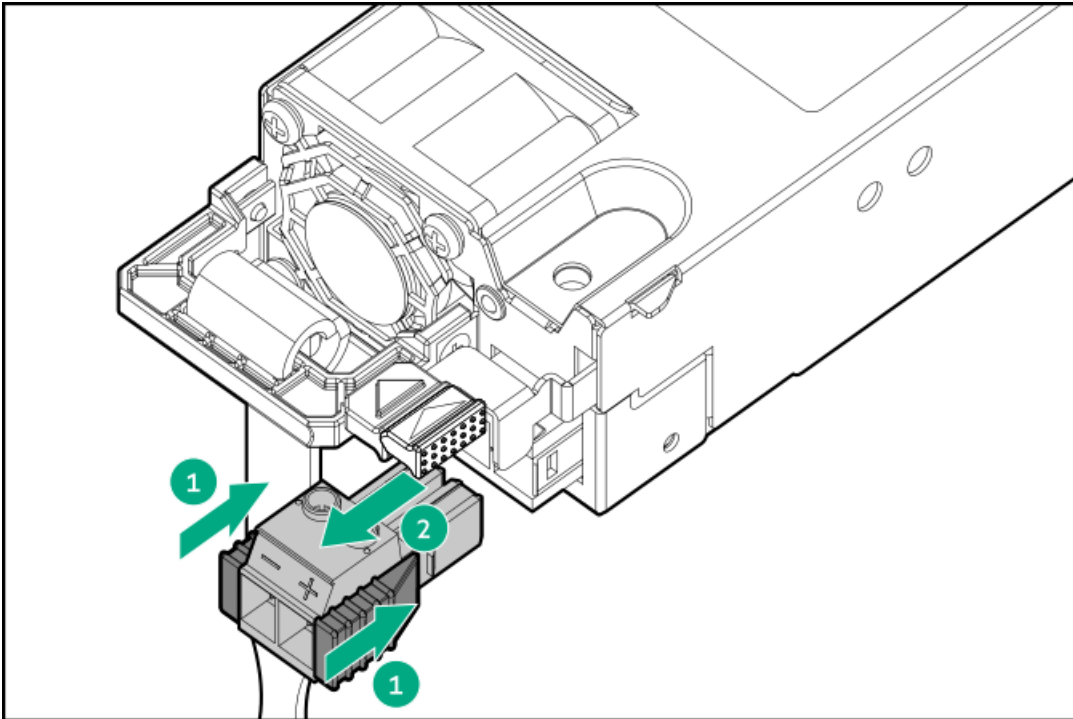

4. Loosen the screws on the terminal block connector.

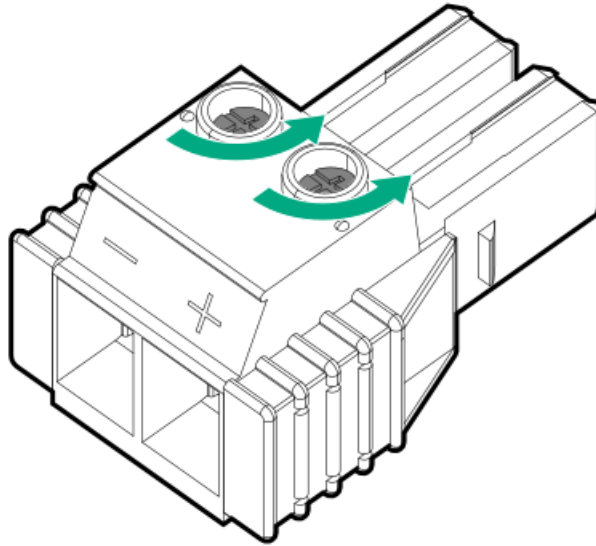

5. Attach the ground (earthed) wire or the green and yellow wire ($6 \text{ mm}^2 = 10 \text{ AWG}$) to the ground screw and washer and tighten to 1.47 N m (13.00 lb-in) of torque. The ground wire must be connected before the -48 V wire and the return wire.

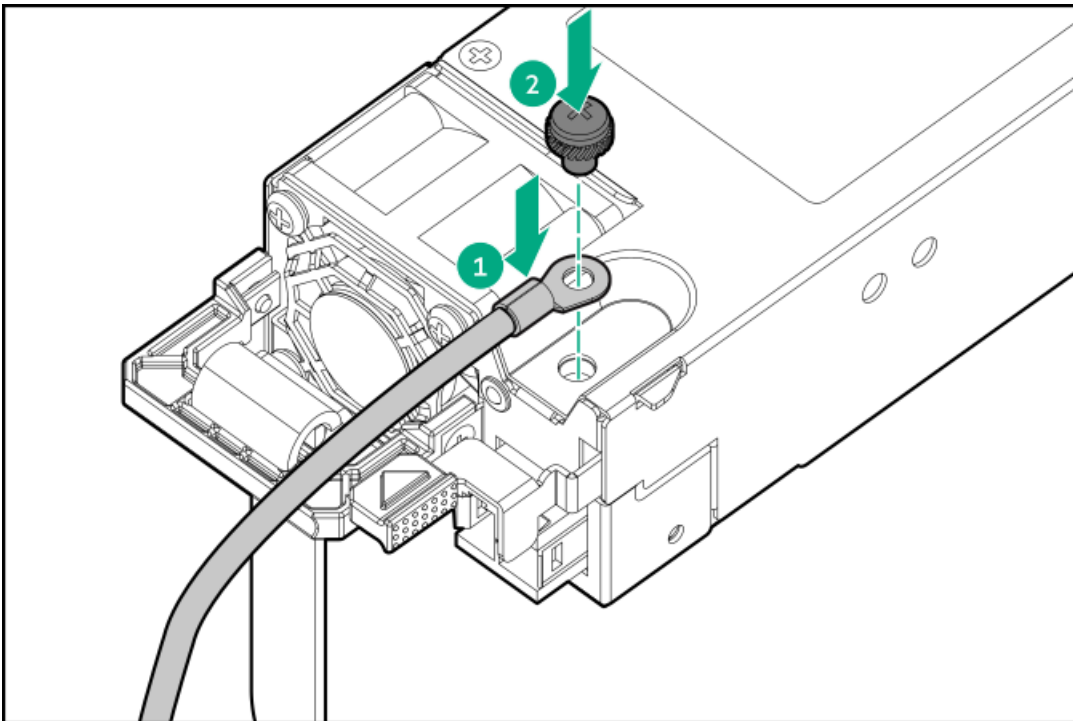

6. Insert the -48 V copper wire ($6 \text{ mm}^2 = 10 \text{ AWG}$) into the left side of the terminal block connector. Use a torque screwdriver to tighten the screw, and set a torque between 0.5 N m (4.43 lb-in) and 0.8 N m (7.08 lb-in).

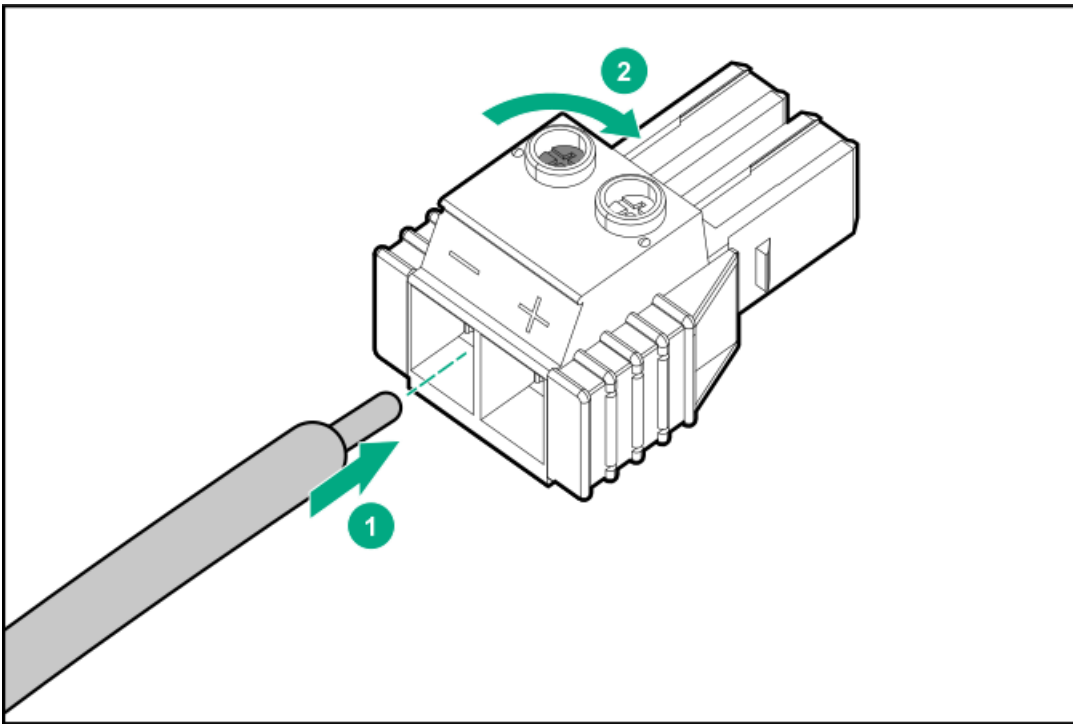

7. Insert the copper return wire (6 mm² = 10 AWG) into the right side of the terminal block connector. Use a torque screwdriver to tighten the screw, and set a torque between 0.5 N m (4.43 lb-in) and 0.8 N m (7.08 lb-in).

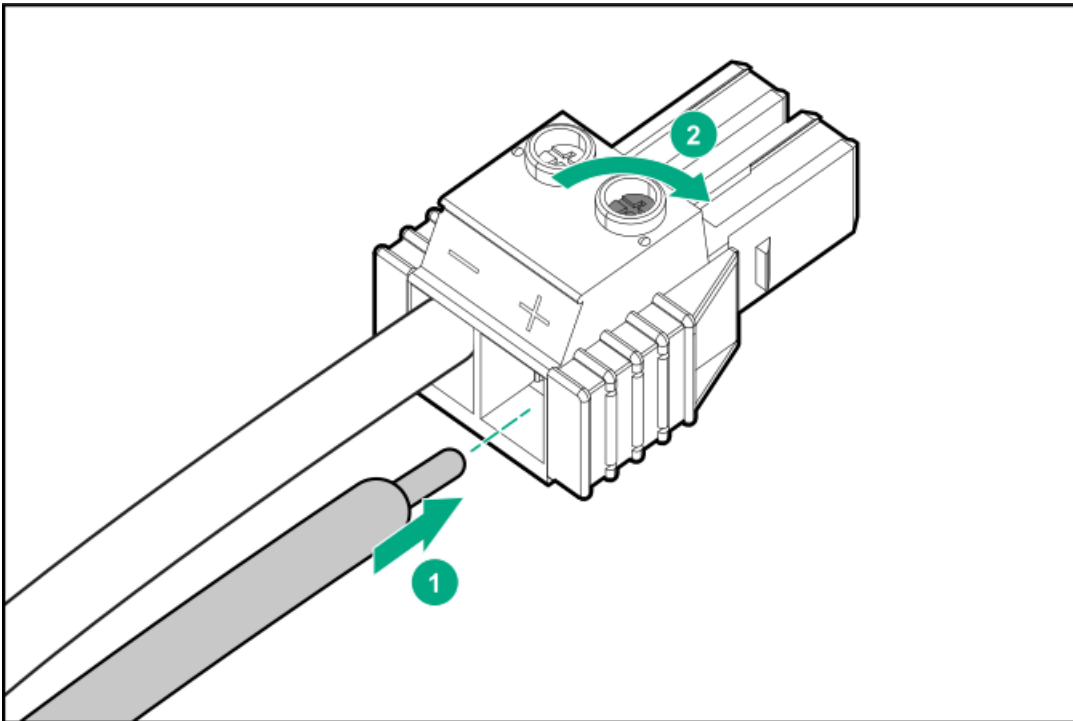

8. Install the terminal block connector into the power supply.

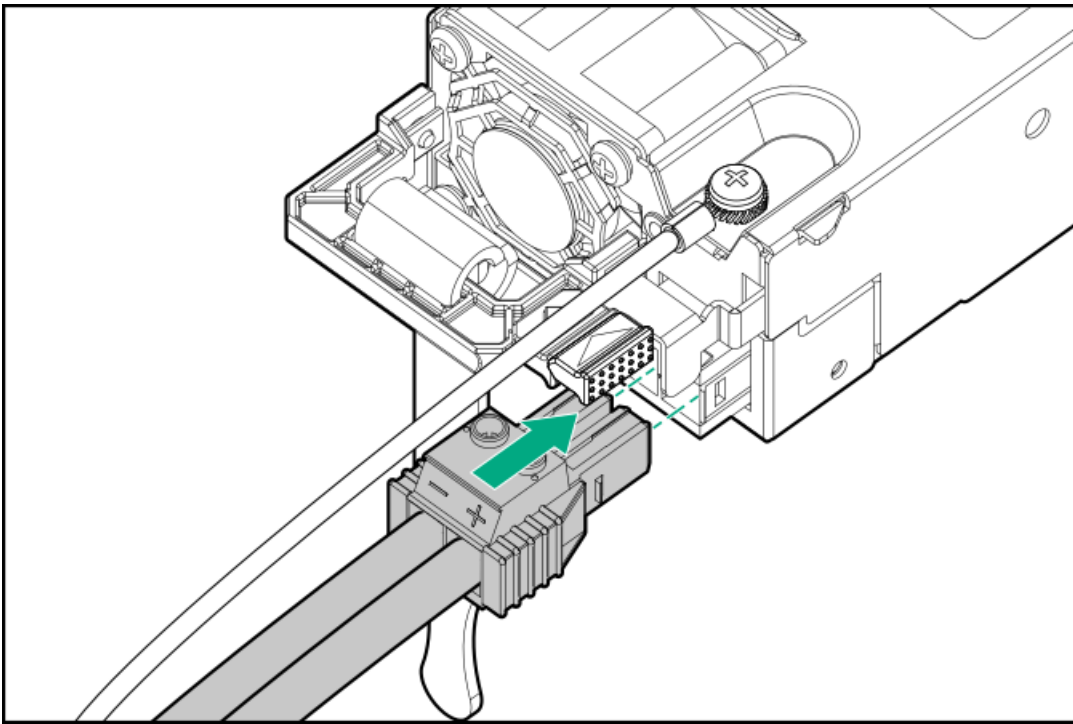

9. Secure the power cord, wires, and cables in the strain relief strap attached to the power supply handle:

- a. Unwrap the strain relief strap from the power supply handle.



CAUTION

Avoid tight bend radii to prevent damaging the internal wires of a power cord or a server cable. Never bend power cords and server cables tight enough to cause a crease in the sheathing.

- b. Secure the power cord, wires, and cables with the strain relief strap. Roll the extra length of the strap around the power supply handle.

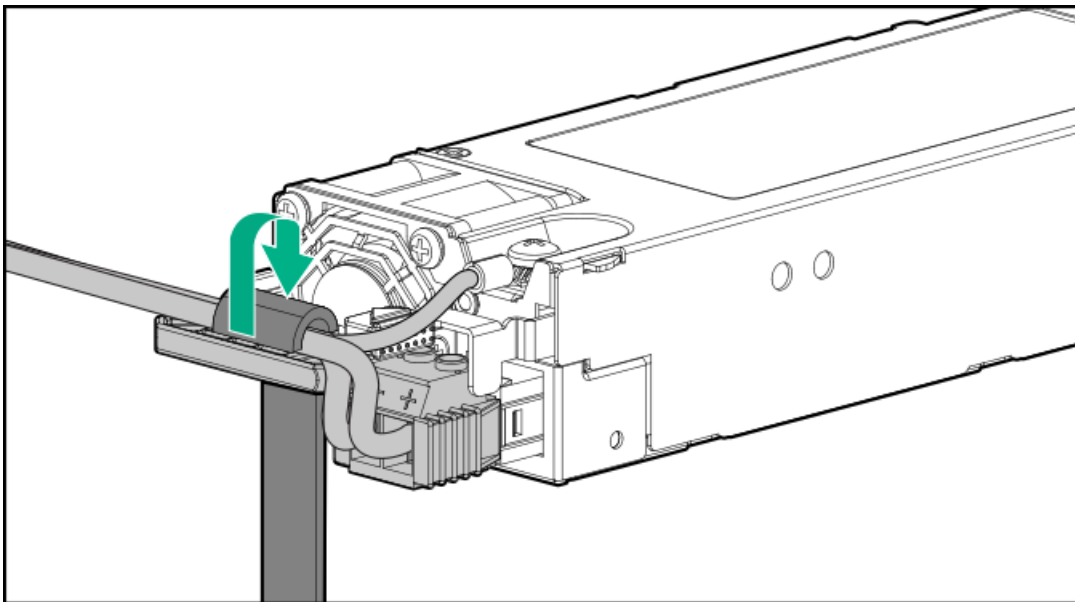

10. If you are installing a power supply in the power supply bay 2, remove the power supply blank.

Retain the blank for future use.



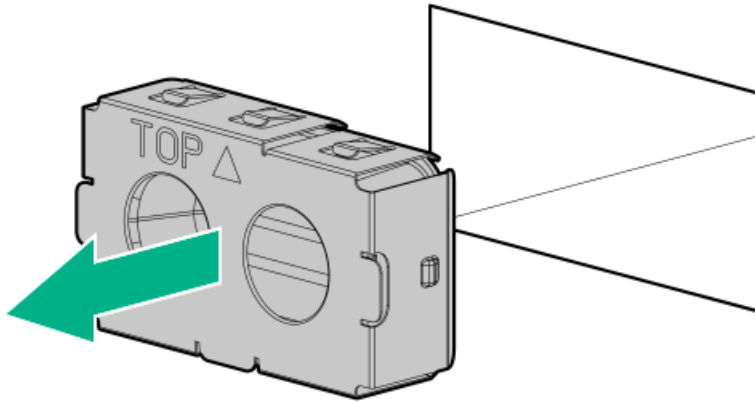

11. Immediately slide the power supply into the bay until it clicks into place.

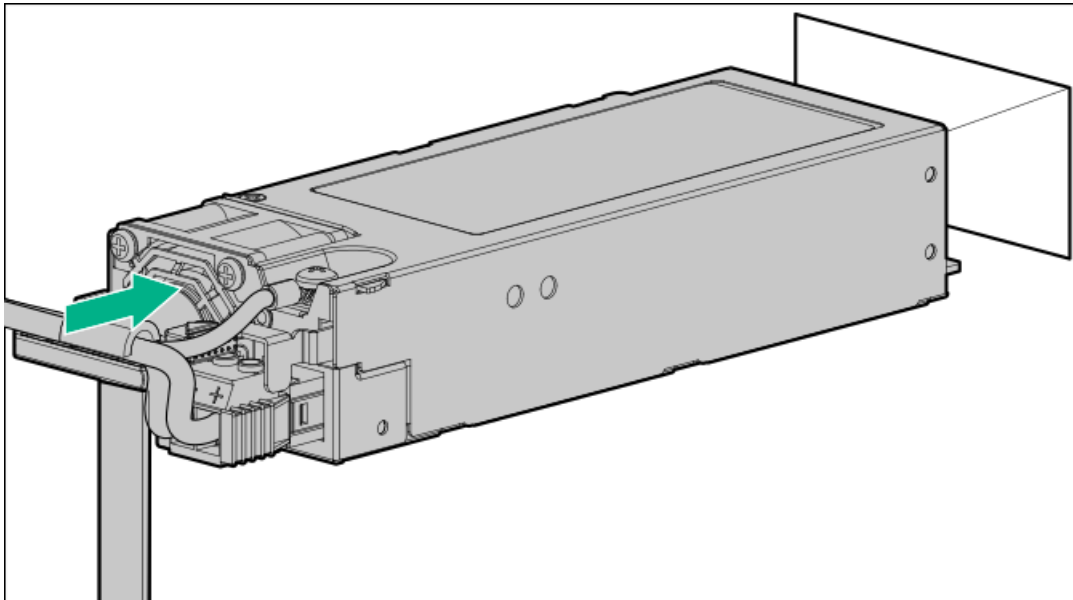

12. Make sure the -48 V DC power source is off or the PDU breaker is in the off position, and then connect the power cord to the -48 V DC power source or PDU.
13. Turn on the -48 V power source or switch the PDU breaker to the on position.
14. Make sure that the power supply LED is green.

Results

The installation procedure is complete.

Connecting a DC power cable to a DC power source

Prerequisites

Before you perform this procedure, make sure that you have the following items available:

- Electrical wire cutter
- Hand crimp tool

About this task



**WARNING**

To reduce the risk of electric shock or energy hazards:

- This equipment must be installed by trained service personnel and in accordance with local and regional electric codes and regulations
- Connect the equipment to a reliably grounded secondary circuit source. A secondary circuit has no direct connection to a primary circuit and derives its power from a transformer, converter, or equivalent isolation device.
- The overcurrent protection for the DC source must not exceed 20 A.

**WARNING**

When installing a DC power supply, the ground wire must be connected before the positive or negative leads.

**WARNING**

Remove power from the power supply before performing any installation steps or maintenance on the power supply.

**CAUTION**

The server equipment connects the earthed conductor of the DC supply circuit to the earthing conductor at the equipment. For more information, see the documentation that ships with the power supply.

**CAUTION**

If a DC connection exists between the earthed conductor of the DC supply circuit and the earthing conductor at the server equipment, the following conditions must be met:

- This equipment must be connected directly to the DC supply system earthing electrode conductor or to a bonding jumper from an earthing terminal bar or bus to which the DC supply system earthing electrode conductor is connected.
- Locate the equipment in the same immediate area (such as adjacent cabinets) as any other equipment that has a connection between the earthed conductor of the same DC supply circuit and the earthing conductor, and also the point of earthing of the DC system. The DC system must be earthed elsewhere.
- The DC supply source is to be located within the same premises as the equipment.
- Switching or disconnecting devices should not be in the earthed circuit conductor between the DC source and the point of connection of the earthing electrode conductor.

Procedure

1. Cut the DC power cord ends no shorter than 150.00 cm (59.06 in).

**IMPORTANT**

The ring terminals must be UL approved and accommodate 10 AWG wires.

**IMPORTANT**

The minimum nominal thread diameter of a pillar or stud type terminal must be 5.30 mm (0.209 in).
The diameter of a screw type terminal must be between 4.83 mm (0.190 in) and 4.97 mm (0.196 in).



2. If the power source requires ring tongues, use a crimping tool to install the ring tongues on the power cord wires and ground wire.
3. Stack each same-colored pair of wires and then attach them to the same power source.

For more information, see the documentation that ships with the power supply.

Drive options

Depending on the drive backplane installed, the server supports the following drive types:

- Hot-plug SFF SAS, SATA, or U.3 NVMe drives
- Hot-plug E3.S PCIe5 NVMe SSDs

This server has no embedded software RAID support. Direct attached SATA drives operates in AHCI mode.

To support hardware RAID, [install a storage controller option](#).

Subtopics

[Drive installation guidelines](#)

[Installing a hot-plug SFF drive](#)

[Installing an E3.S drive](#)

Drive installation guidelines

Observe the following general guidelines:

- The system automatically sets all drive numbers.



CAUTION

When a server is purchased without any drive installed, some drive bays might be empty while other drive bays might be populated with drive blanks. To maintain proper system cooling, do not operate the server without a drive or a drive blank installed.

- If only one drive is used, install it in the bay with the lowest drive number.
For drive numbering, see [Drive bay numbering](#).
- This server does not support mixed drive types.
- When installing NVMe drives, install the same drive type. Mixed NVMe drives are not supported.
- All drives grouped into the same drive array must meet the following criteria:
 - They must be either all hard drives or all solid-state drives.
 - Drives must be the same capacity to provide the greatest storage space efficiency.

Installing a hot-plug SFF drive

Prerequisites

The 2 SFF drive configuration requires the presence of four standard fans. For more information, see [Fan and heatsink requirements](#).

About this task



CAUTION

A discharge of static electricity from a finger or other conductor might damage system boards or other static-sensitive devices. To prevent damage, observe [antistatic precautions](#).



CAUTION

To prevent improper cooling and thermal damage, do not operate the server unless all bays are populated with either a component or a blank.

Procedure

1. [Back up all server data](#).
2. If installed, [remove the front bezel](#).
3. Remove the drive blank.

Retain the blank for future use.

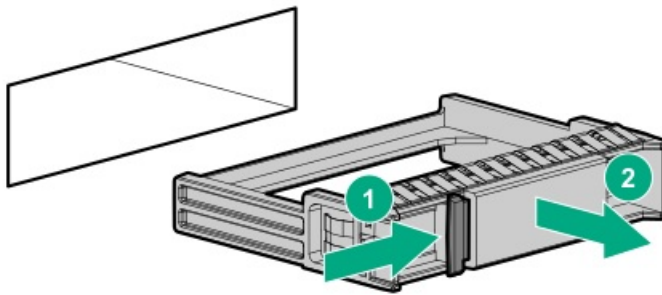

4. Prepare the drive.

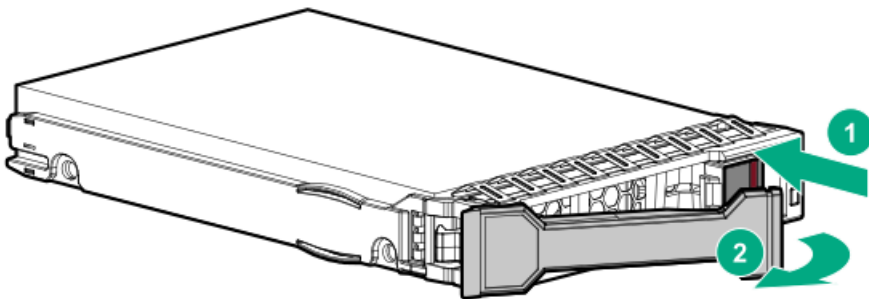

5. Install the drive.

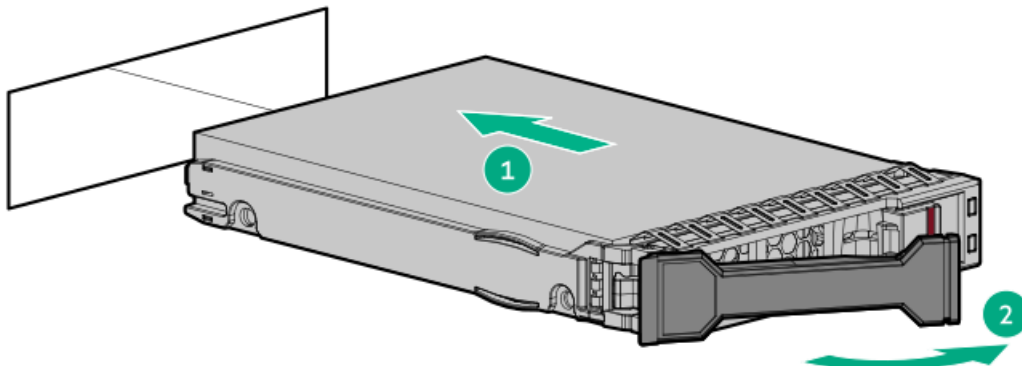

6. [Determine the status of the drive from the drive LED definitions](#).
7. If removed, [install the front bezel](#).
8. To configure drive arrays, see the [relevant storage controller guide](#).

Results

The installation procedure is complete.

Installing an E3.S drive

Prerequisites

High performance fans are installed. For more information, see the following:

- [Fan and heatsink requirements](#)
- [Installing a fan](#)

About this task



CAUTION

A discharge of static electricity from a finger or other conductor might damage system boards or other static-sensitive devices. To prevent damage, observe [antistatic precautions](#).



CAUTION

To prevent improper cooling and thermal damage, do not operate the server unless all bays are populated with either a component or a blank.

Procedure

1. [Back up all server data](#).
2. If installed, [remove the front bezel](#).
3. Remove the drive blank.

Retain the blank for future use.

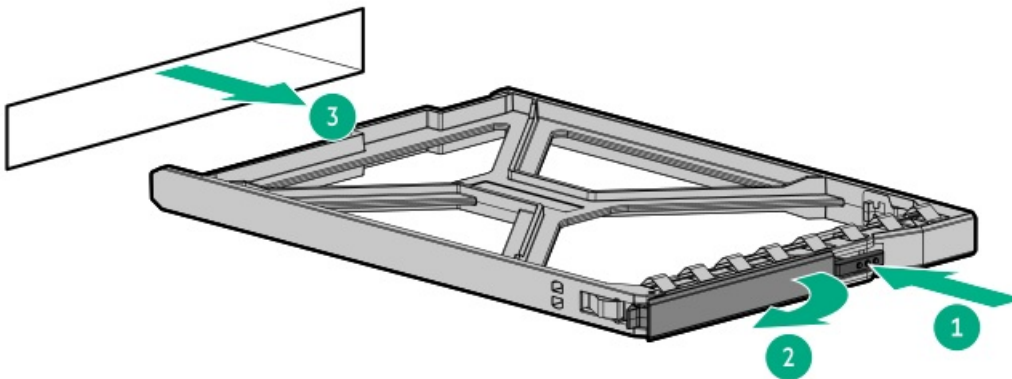

4. Prepare the drive.

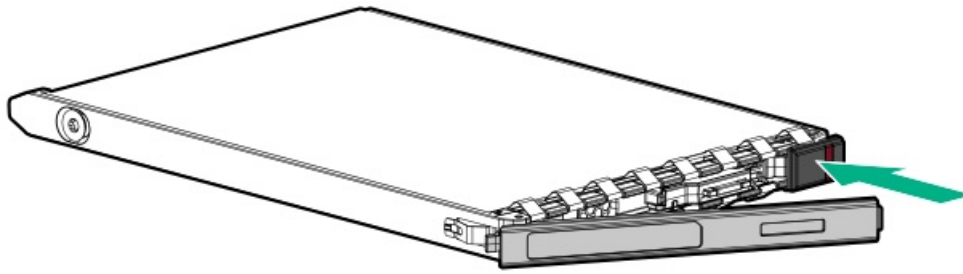

5.  **NOTE**
To make sure that the drive has installed successfully, make sure that the latch is engaged with the drive cage.

Install the drive.

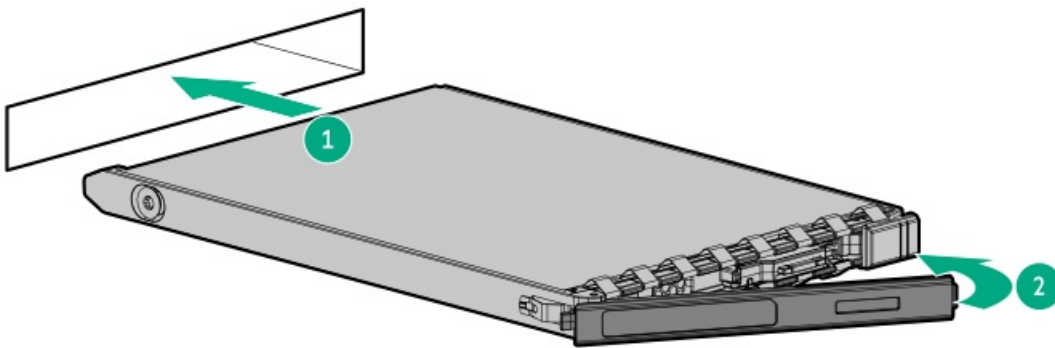

6. [Determine the status of the drive from the drive LED definitions.](#)
7. If removed, [install the front bezel.](#)
8. To configure drive arrays, see the [relevant storage controller guide.](#)

Results

The installation procedure is complete.

Drive cage options

Subtopics

[Converting from 2 SFF to 4 E3.S drive configuration](#)

[Upgrading from 4 E3.S to 6 E3.S drive configuration](#)

[Converting from 4 E3.S to 2 SFF drive configuration](#)

Converting from 2 SFF to 4 E3.S drive configuration



Prerequisites

- High performance fans are installed. For more information, see the following:
 - [Fan and heatsink requirements](#)
 - [Installing a fan](#)
- Before you perform this procedure, make sure that you have the following items available:
 - 4 E3.S conversion kit (P71985-B21)
 - T-10 Torx screwdriver
 - T-15 Torx screwdriver

About this task

The 4 E3.S conversion kit includes the following drive backplane:

- 4 E3.S 32G x4 NVMe UBM10

For more information on the drive backplane description, see [Drive backplane naming convention](#).



CAUTION

A discharge of static electricity from a finger or other conductor might damage system boards or other static-sensitive devices. To prevent damage, observe [antistatic precautions](#).



CAUTION

To prevent improper cooling and thermal damage, do not operate the server unless all bays are populated with either a component or a blank.

Procedure

1. [Back up all server data](#).
2. If installed, [remove the front bezel](#).
3. [Power down the server](#).
4. Remove all power:
 - a. Disconnect each power cord from the power source.
 - b. Disconnect each power cord from the server.
5. Disconnect all peripheral cables from the server.
6. [Remove the server from the rack](#).
7. Place the server on a flat, level work surface.
8. [Remove the access panel](#).
9. [Remove the air baffle](#).

Removing the 2 SFF drive cage

10. Remove the drives.

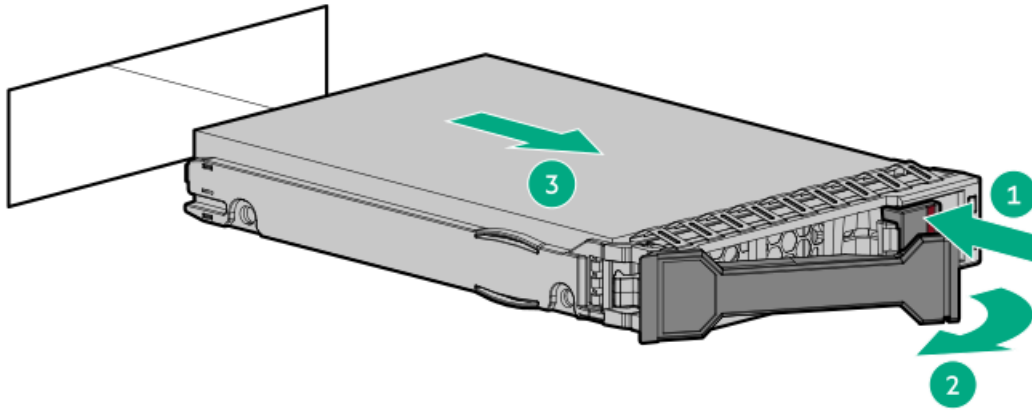

11. Disconnect the 2 SFF signal and power cables from the drive backplane and system board.
12. Remove the drive cage blank screw, and then slide the blank out of the drive cage.

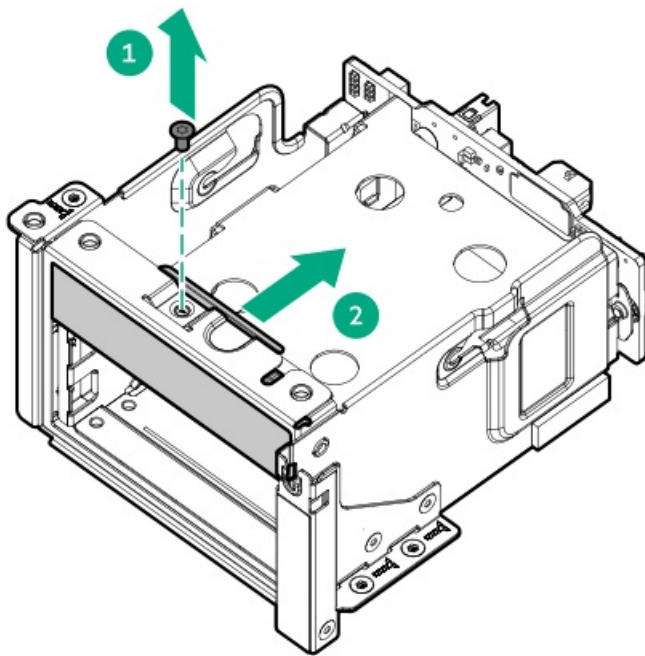

13. Remove the 2 SFF drive cage:
 - a. Remove the screws.

Retain the screws and grommets. The screws will be used to secure the new drive cage assembly.



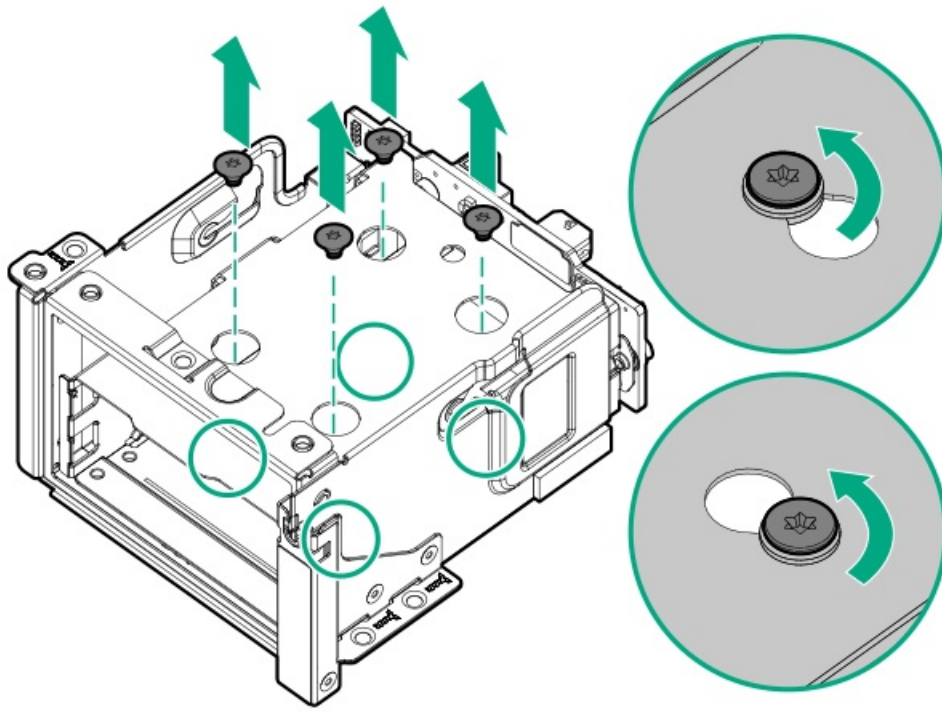

b. Slide the drive cage backward, and then lift it out of the drive base cage.

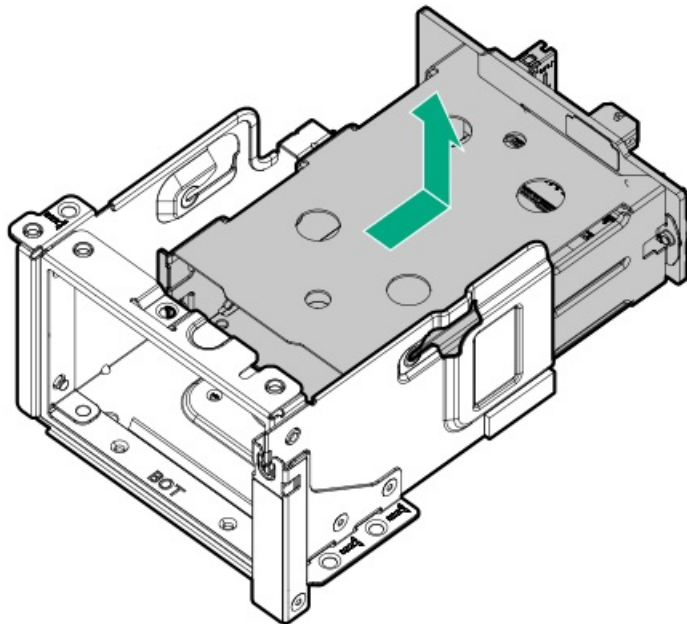

Installing the 4 E3.S drive cage

14. Remove the 2 E3.S connector bracket screw, and then pivot the bracket upward to remove it from the drive cage.



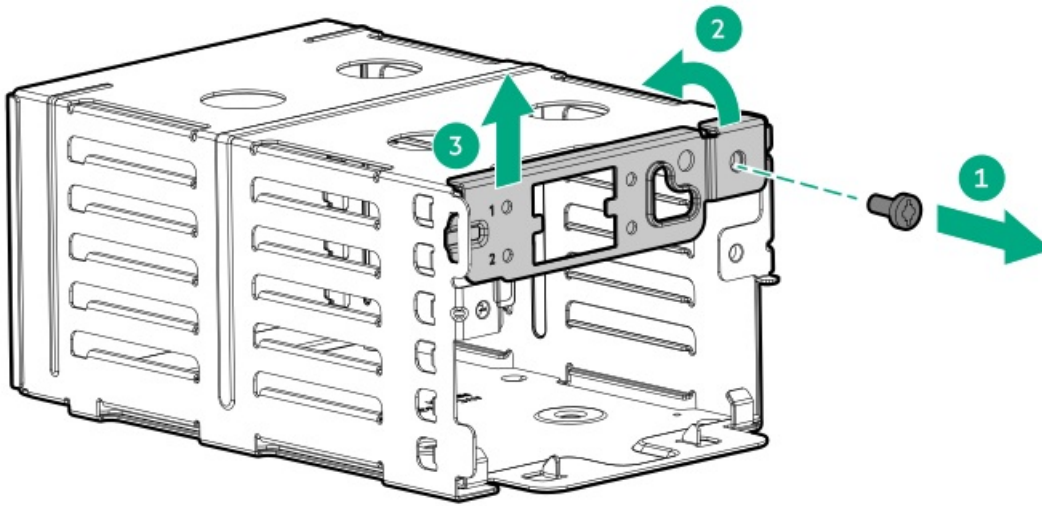

15. Install the 4 E3.S drive backplane onto the 4 E3.S drive cage.

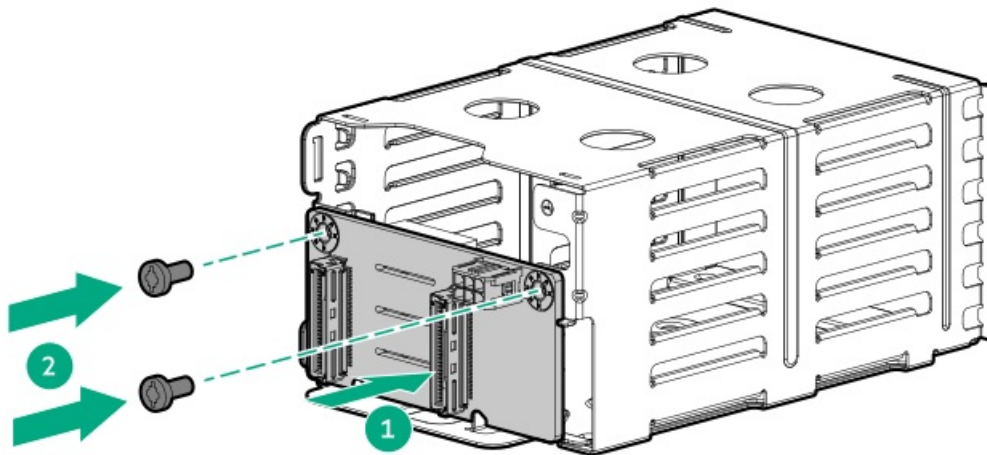

16. Install the connector bracket back onto the drive cage:

- a. Insert the tip of the connector bracket into the drive cage, and then pivot it down.
- b. Install the bracket screw.



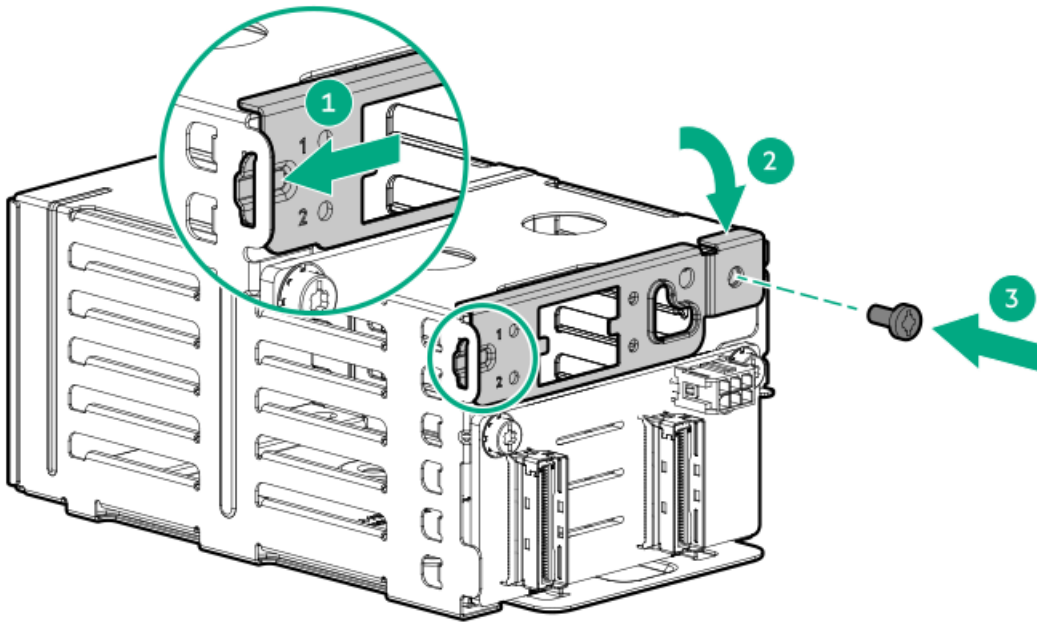

17. Install the 4 E3.S drive cage:

- a. Slide the drive cage into place.

Make sure the ear on the right side of the drive cage is flush against the drive base cage.

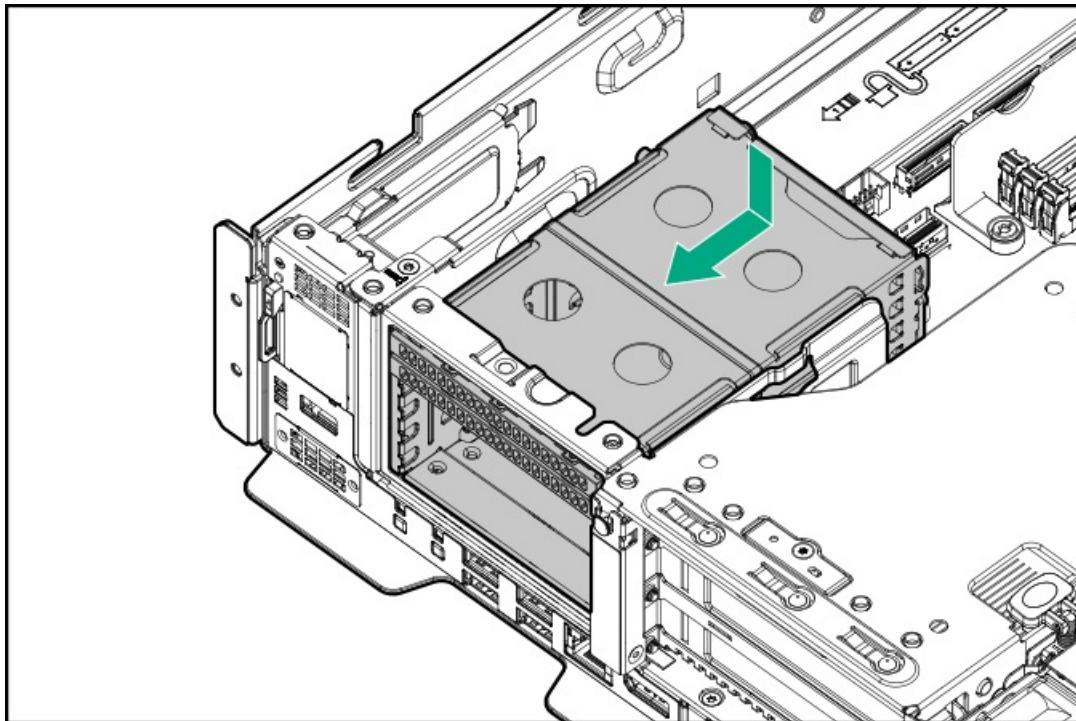

- b. Install the screws.



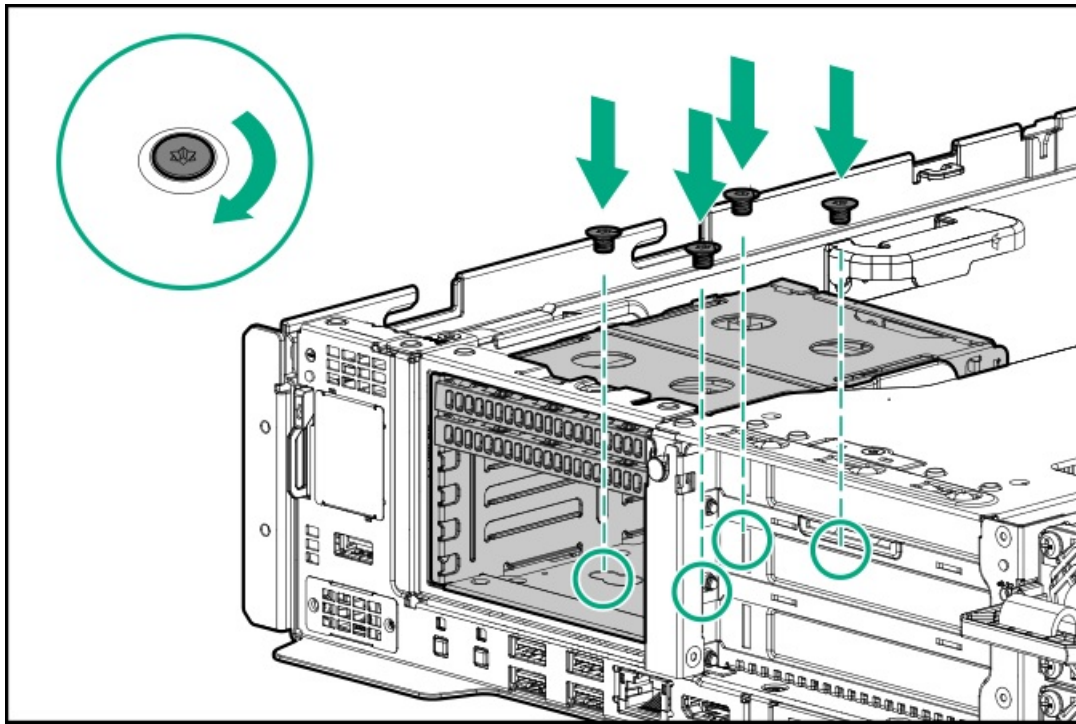

18. Connect the following cables to the drive backplane and system board:

- [6 E3.S drive power Y cable](#)
- [4 E3.S drive signal cable](#)

19. [Install the E3.S drives.](#)

20. [Install the air baffle.](#)

21. [Install the access panel.](#)

22. [Install the server into the rack.](#)

23. Connect all peripheral cables to the server.

24. Connect each power cord to the server.

25. Connect each power cord to the power source.

26. [Power up the server.](#)

27. If removed, [install the front bezel.](#)

Results

The installation procedure is complete.

Upgrading from 4 E3.S to 6 E3.S drive configuration

Prerequisites

Before you perform this procedure, make sure that you have the following items available:

- One of the following 6 E3.S enablement cable options:
 - 6 E3.S enablement cable for system board connection (P71981-B21)
 - 6 E3.S enablement cable for type-p controller (P72004-B21)

- Phillips No. 1 screwdriver
- T-10 Torx screwdriver
- T-15 Torx screwdriver
- Spudger or any small prying tool

About this task



CAUTION

A discharge of static electricity from a finger or other conductor might damage system boards or other static-sensitive devices. To prevent damage, observe [antistatic precautions](#).



CAUTION

To prevent improper cooling and thermal damage, do not operate the server unless all bays are populated with either a component or a blank.

Procedure

1. [Back up all server data](#).
2. If installed, [remove the front bezel](#).
3. [Power down the server](#).
4. Remove all power:
 - a. Disconnect each power cord from the power source.
 - b. Disconnect each power cord from the server.
5. Disconnect all peripheral cables from the server.
6. [Remove the server from the rack](#).
7. Place the server on a flat, level work surface.
8. [Remove the access panel](#).
9. [Remove the air baffle](#).
10. Remove the E3.S drive cage fillers:
 - a. Insert a small-slotted screwdriver into the slot on the far left to push the release latch.
 - b. Remove the E3.S drive cage filler.

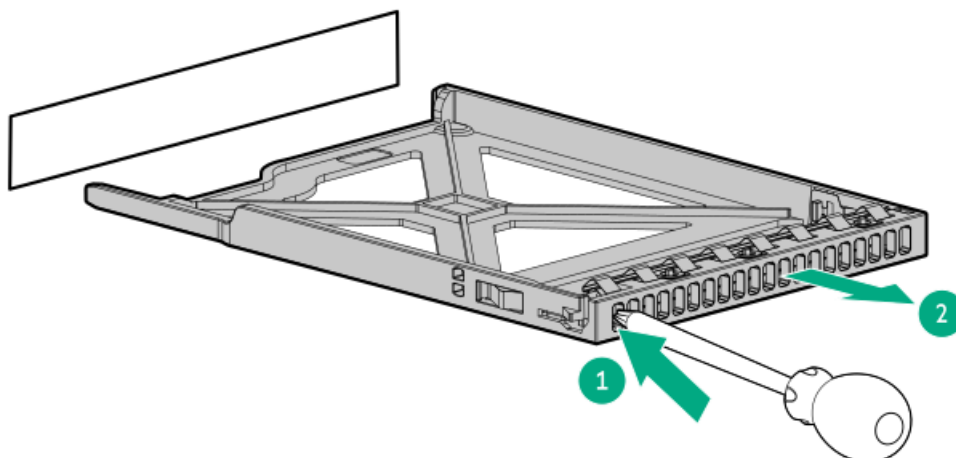

11. Remove the drives.

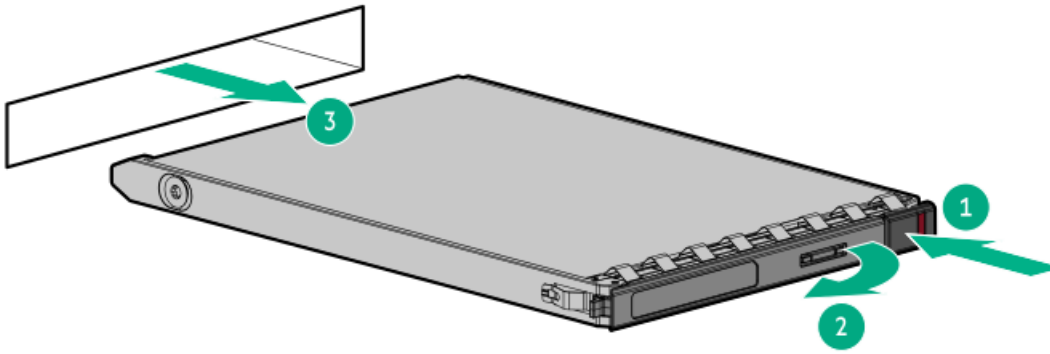

12. Disconnect the 4 E3.S signal and power cables from the drive backplane.

13. Remove the 4 E3.S drive cage:

- a. Remove the screws.

Retain all screws for future use.

- b. Slide the 4 E3.S drive cage backward and then lift it out of the drive base cage.

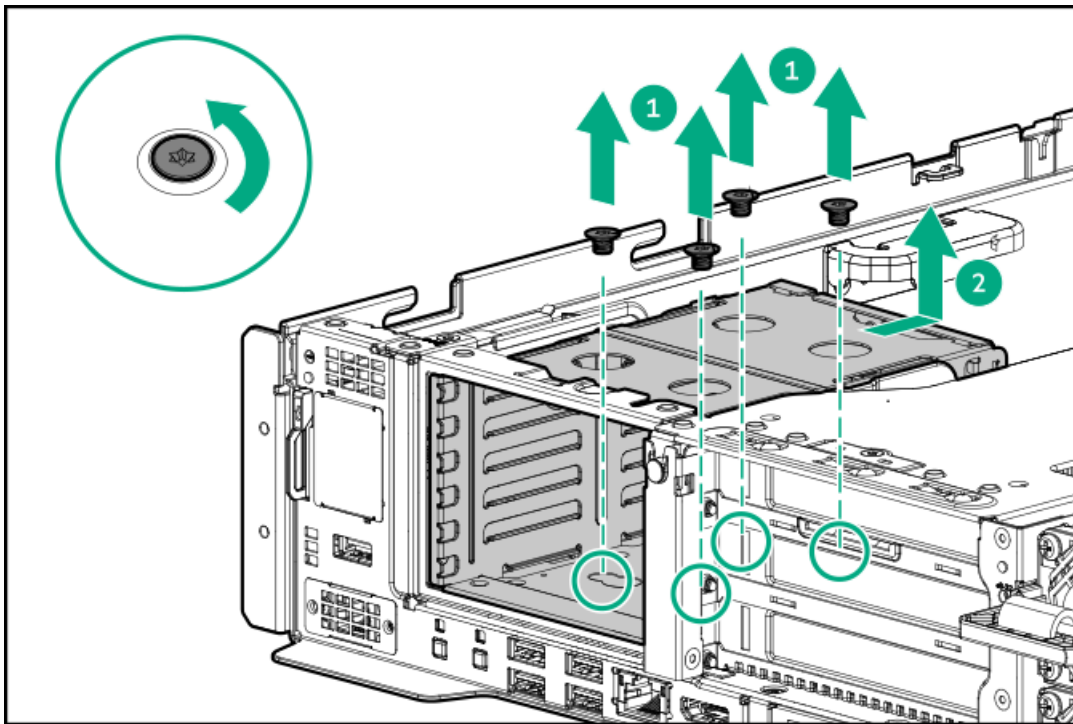

14. Remove the screw from the 2 E3.S cable connector bracket, and then pivot the bracket upward to remove it from the drive cage.

Retain the screw and bracket for future use.

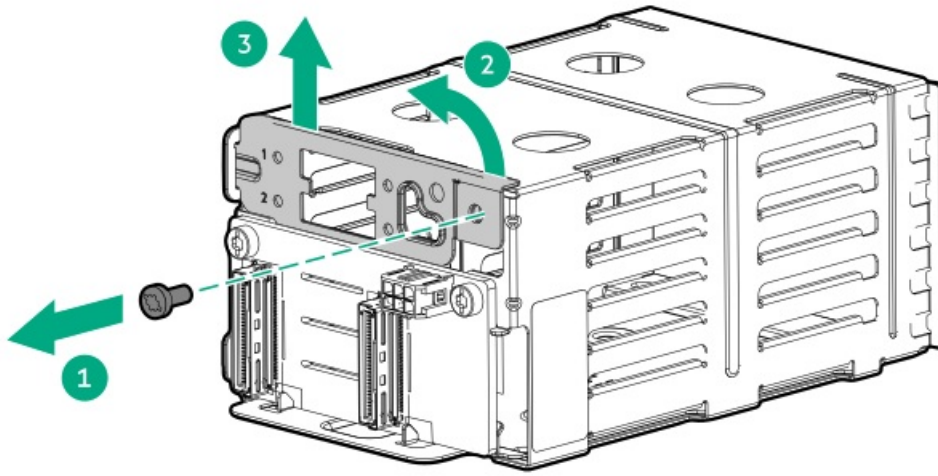

Installing the 6 E3.S enablement cable option

15. Install the 2 E3.S connector:

- a. Insert the connector into the bracket.
- b. Install the screws.

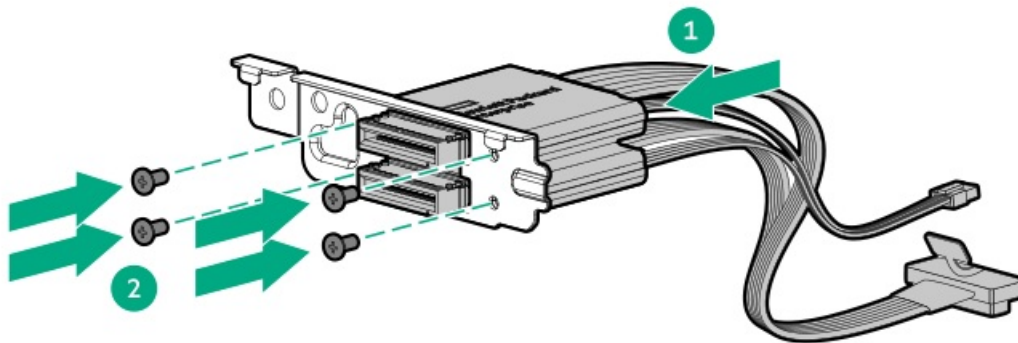

16. Install the connector bracket back onto the drive cage:

- a. Insert the tip of the connector bracket into the drive cage, and then pivot it down.
- b. Install the bracket screw.



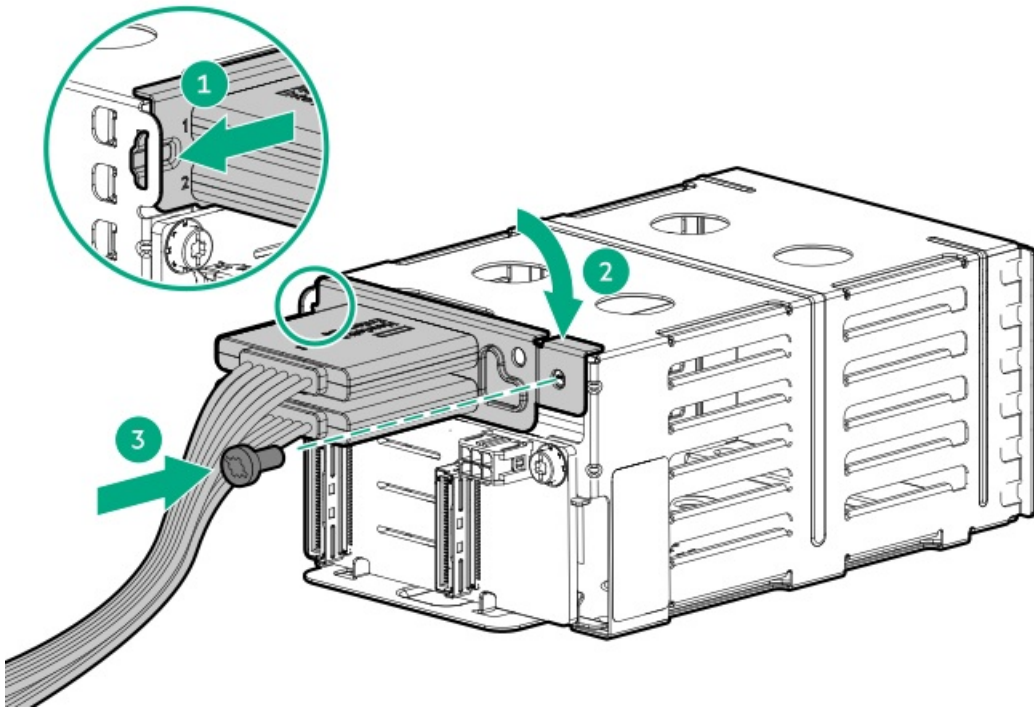

17. Install the 6 E3.S drive cage:

- a. Slide the drive cage into place.

Make sure the ear on the right side of the drive cage is flush against the drive base cage.

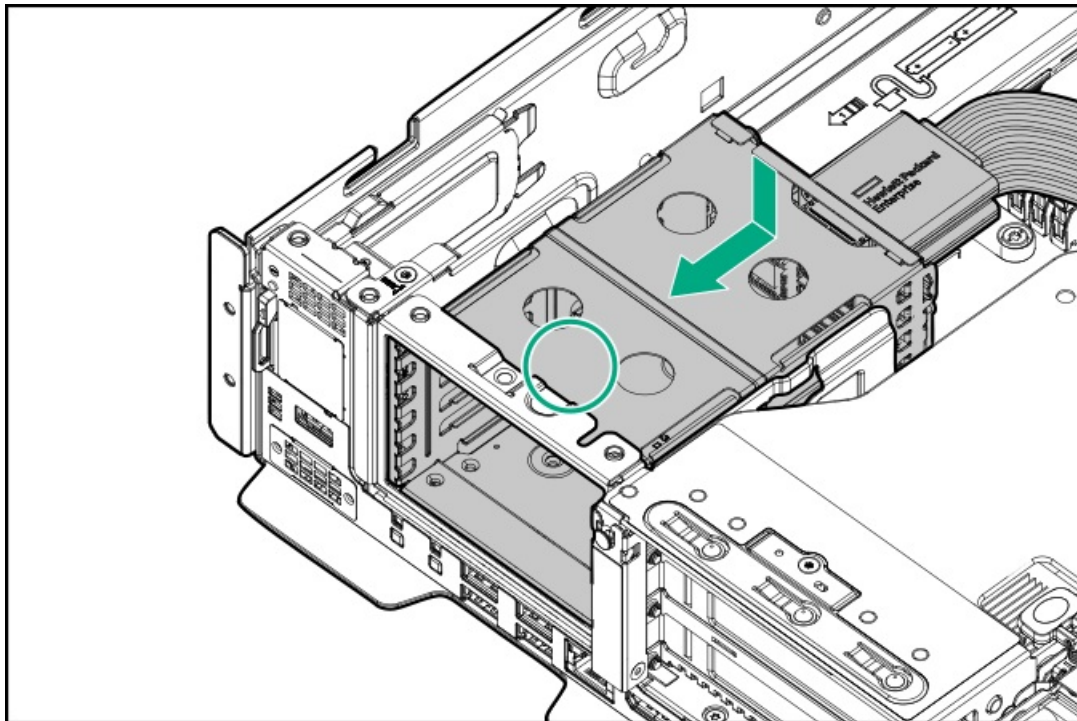

- b. Install the screws.



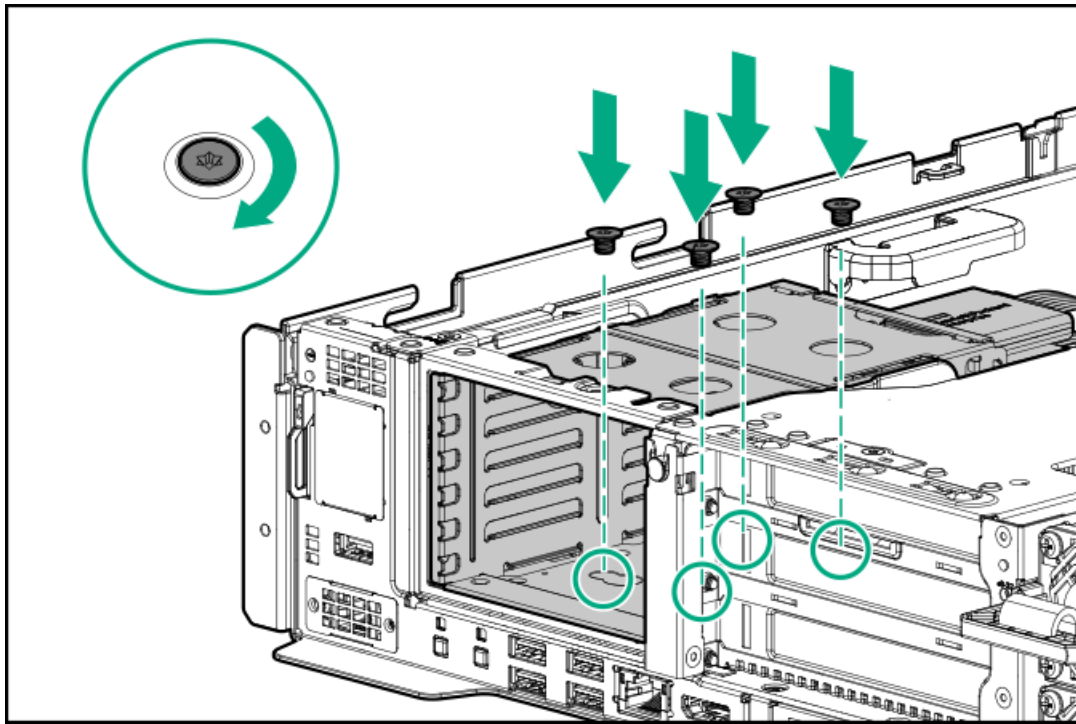

18. Connect the drive signal and power cables:

- [6 E3.S drive power Y cable](#)
- [4 E3.S drive signal cable](#)
- [2 E3.S drive signal cable](#)

19. [Install the E3.S drives.](#)

20. [Install the air baffle.](#)

21. [Install the access panel.](#)

22. [Install the server into the rack.](#)

23. Connect all peripheral cables to the server.

24. Connect each power cord to the server.

25. Connect each power cord to the power source.

26. [Power up the server.](#)

27. If removed, [install the front bezel.](#)

Results

The installation procedure is complete.

Converting from 4 E3.S to 2 SFF drive configuration

Prerequisites

- Standard fans are installed. For more information, see the following:
 - [Fan and heatsink requirements](#)
 - [Installing a fan](#)

- Before you perform this procedure, make sure that you have the following items available:
 - 2 SFF conversion kit (P71977-B21)
 - T-10 Torx screwdriver
 - T-15 Torx screwdriver
 - Small slotted screwdriver

About this task

The 2 SFF conversion kit includes the following drive backplane:

- 2 SFF 24G x4 U.3 NVMe / SAS / SATA UBM6 BC

For more information on the drive backplane description, see [Drive backplane naming convention](#).



CAUTION

A discharge of static electricity from a finger or other conductor might damage system boards or other static-sensitive devices. To prevent damage, observe [antistatic precautions](#).



CAUTION

To prevent improper cooling and thermal damage, do not operate the server unless all bays are populated with either a component or a blank.

Procedure

1. [Back up all server data](#).
2. If installed, [remove the front bezel](#).
3. [Power down the server](#).
4. Remove all power:
 - a. Disconnect each power cord from the power source.
 - b. Disconnect each power cord from the server.
5. Disconnect all peripheral cables from the server.
6. [Remove the server from the rack](#).
7. Place the server on a flat, level work surface.
8. [Remove the access panel](#).
9. [Remove the air baffle](#).

Removing the 4 E3.S drive cage

10. Remove the drives.



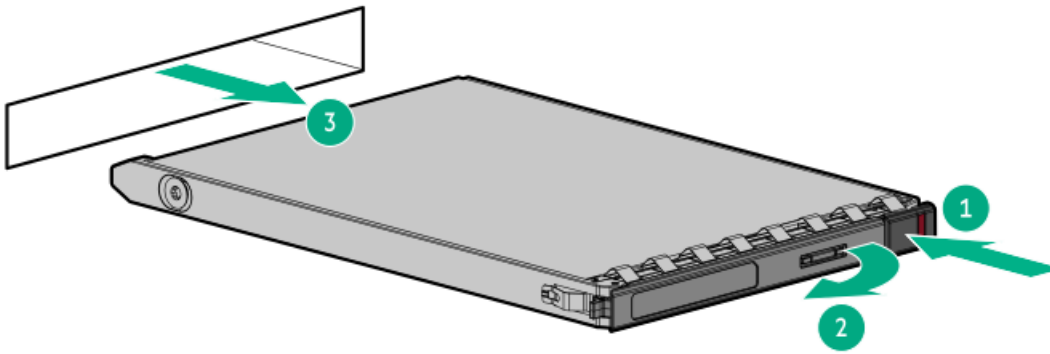

11. Remove the E3.S drive cage fillers:

- a. Insert a small-slotted screwdriver into the slot on the far left to push the release latch.
- b. Remove the E3.S drive cage filler.

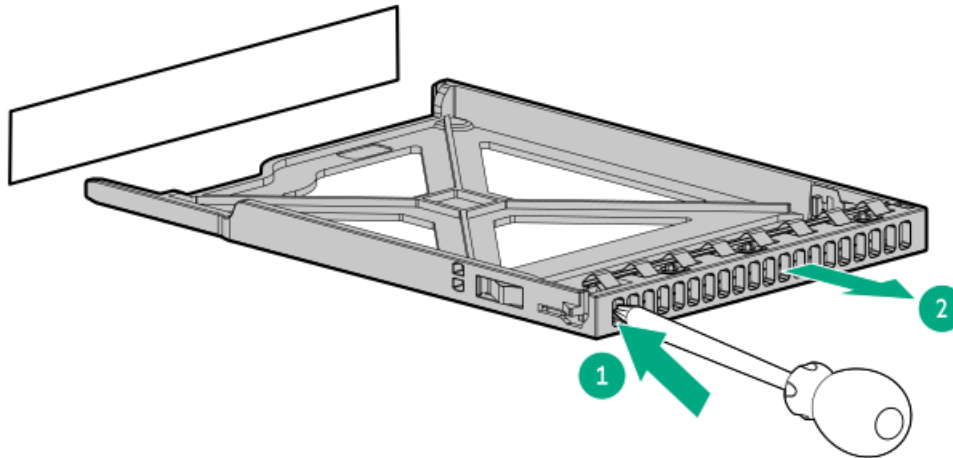

12. Disconnect the 4 E3.S signal and power cables from the system board.

13. Remove the 4 E3.S drive cage:

- a. Remove the screws.
Retain all screws for future use.
- b. Slide the 4 E3.S drive cage backward and then lift it out of the drive base cage.



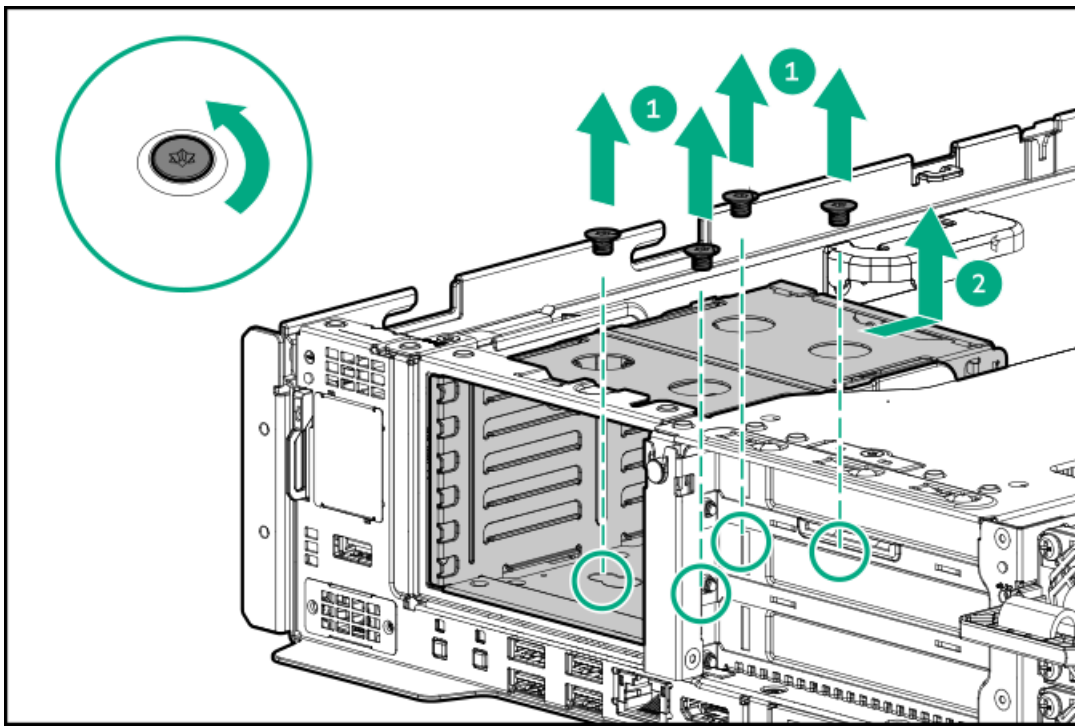

Installing the 2 SFF drive cage

14. Install the grommets onto the underside of the drive cage.

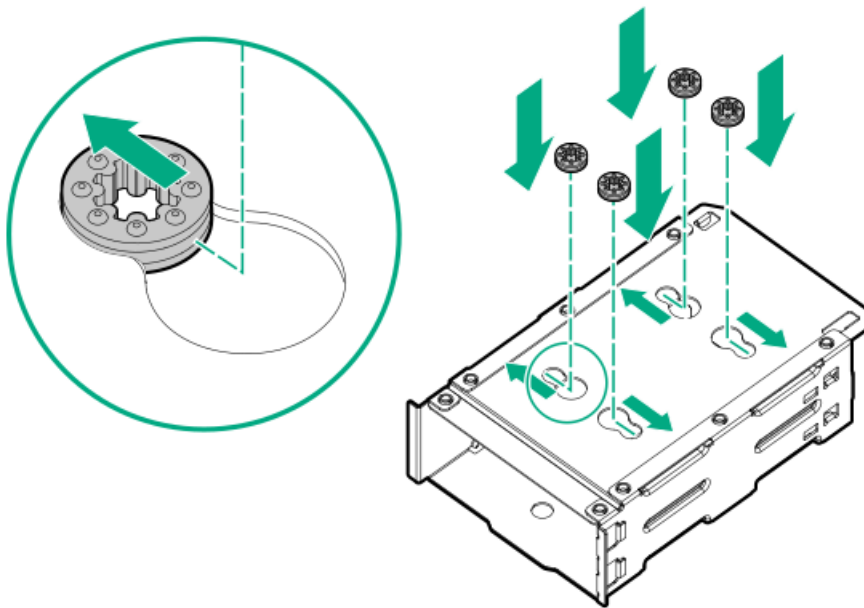

15. Install the 2 SFF drive backplane onto the drive cage.



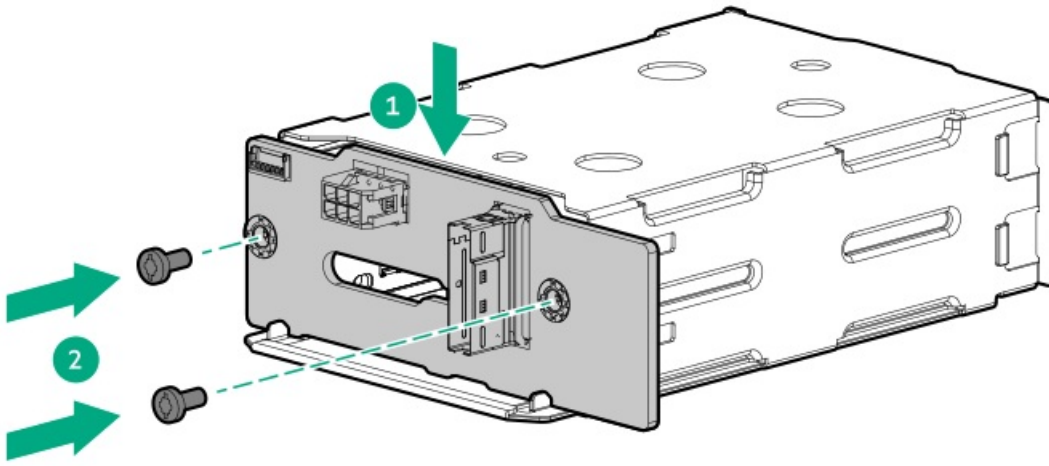

16. Install the 2 SFF drive cage:

- a. Slide the drive cage into place.

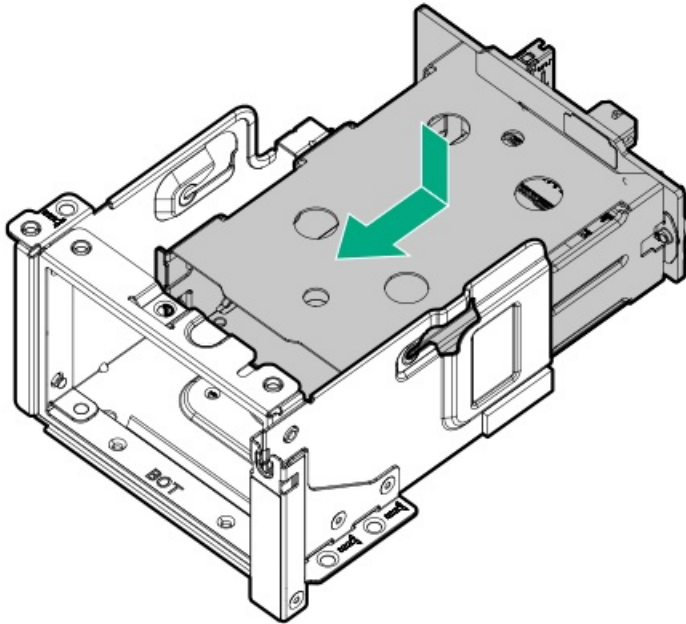

- b. Install the screws.

Verify that the screws pass through the grommets.



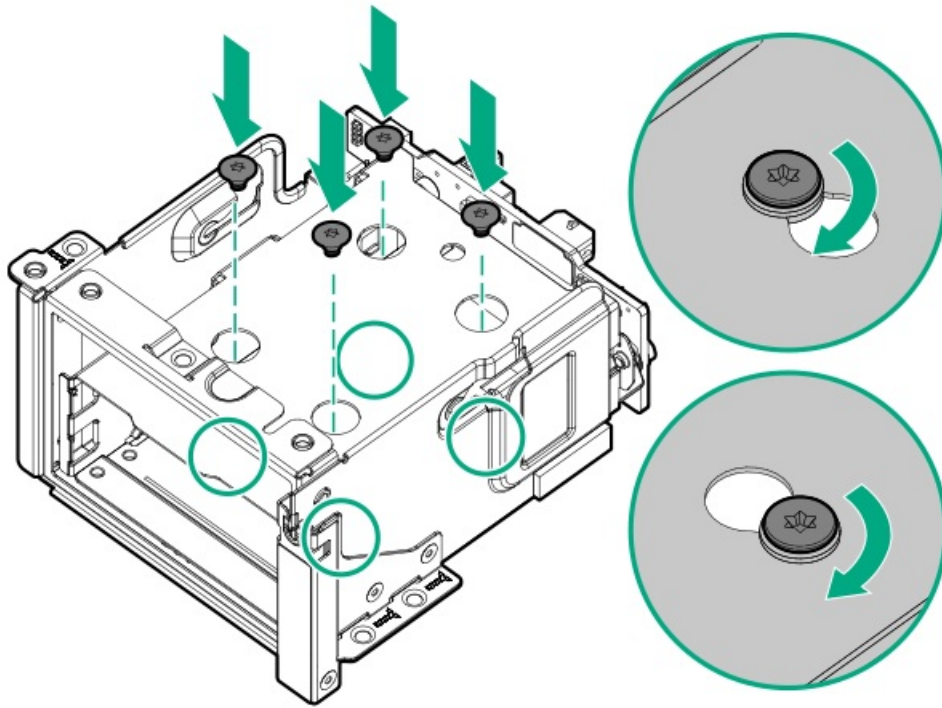

c. Install the 2 SFF drive cage blank.

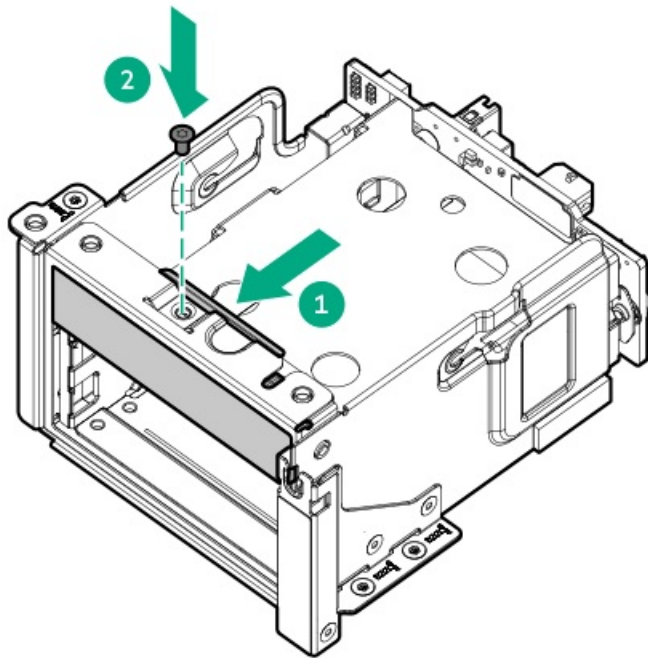

17. Connect the drive signal and power cables to the system board:

- 2 SFF drive power cable
- 2 SFF drive signal cable

18. Install the SFF drives.

19. Install the air baffle.

20. Install the access panel.



21. [Install the server into the rack.](#)
22. Connect all peripheral cables to the server.
23. Connect each power cord to the server.
24. Connect each power cord to the power source.
25. [Power up the server.](#)
26. If removed, [install the front bezel.](#)

Results

The installation procedure is complete.

Fan options

To provide sufficient airflow to the system, the server is by default populated by four fans. The fans can either be standard, single-rotor fans (P72586-B21) or high performance, single-rotor fans (P72581-B21). Mixed fan configuration is not supported.

All fan bays must be populated regardless of the hardware configurations. To maintain proper system cooling, [install the correct fan type required for specific hardware configurations.](#)

Subtopics

[Fan mode behavior](#)

[Installing a fan](#)

Fan mode behavior

The default four fan configuration provides redundant fan support. In redundant fan mode, if a fan rotor fails or is missing:

- The system switches to nonredundant fan mode. The system continues to operate in this mode.
- The system health LED flashes amber.

If a second fan rotor failure or a missing fan occurs, the operating system gracefully shuts down.

Installing a fan

Prerequisites

Review the [fan and heatsink requirements](#) for specific hardware configurations.

About this task

The installation and removal procedures for the standard and high performance fans are the same.



IMPORTANT

Do not mix standard and high performance fans in the same server.





CAUTION

A discharge of static electricity from a finger or other conductor might damage system boards or other static-sensitive devices. To prevent damage, observe antistatic precautions.

Procedure

1. Extend the server out of the rack.
2. Remove the access panel.
3. Remove the existing fans:
 - a. Press and hold the latch.
 - b. Lift the fan from the fan cage.

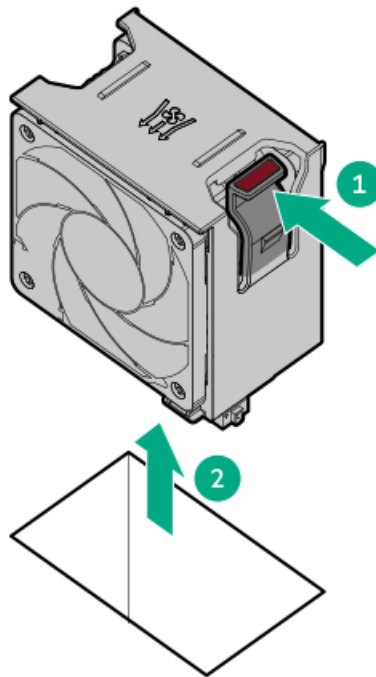

4. Install new fans:
 - a. Lower the fan into the fan bay.
 - b. Press down on the fan to make sure that it is seated firmly in the bay.

A click sound indicates that the fan is properly engaged.



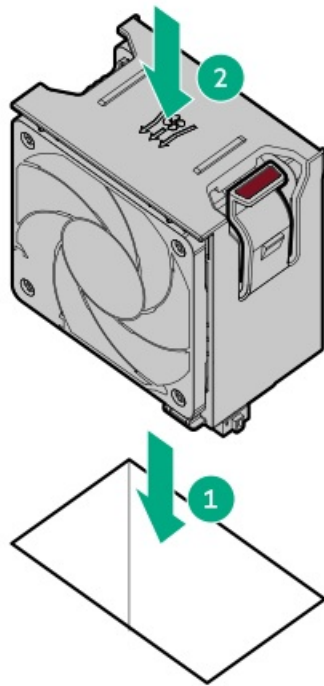

5. [Install the access panel.](#)
6. [Install the server into the rack.](#)

Results

The installation procedure is complete.

Memory option

The server has 6 DIMM slots supporting HPE DDR5 SmartMemory (RDIMM).

The arrow points to the front of the server.

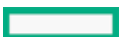
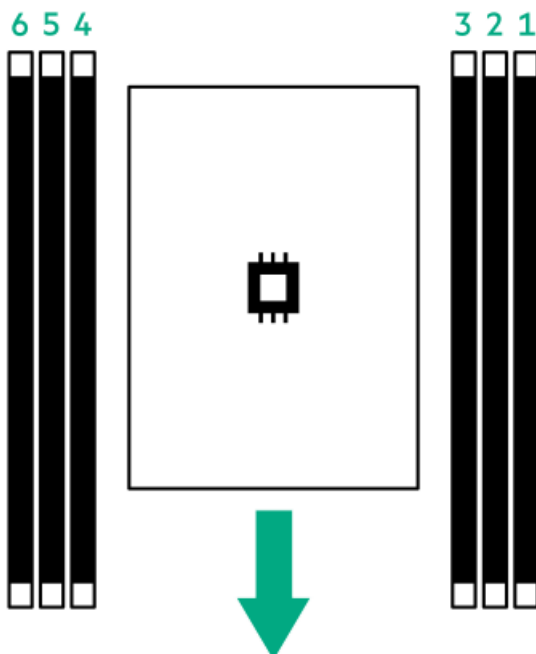

Subtopics

[HPE SmartMemory speed and population information](#)

[DIMM installation guidelines](#)

[Installing a DIMM](#)

HPE SmartMemory speed and population information

For information about memory speed and server-specific DIMM population rules for HPE servers using AMD EPYC 8004 Series Processor, see the relevant memory technical paper in:

<https://www.hpe.com/docs/server-memory>

DIMM installation guidelines

When handling a DIMM, observe the following:

- Observe [antistatic precautions](#).
- Handle the DIMM only along the edges.
- Do not touch the components on the sides of the DIMM.
- Do not touch the connectors on the bottom of the DIMM.
- Never wrap your fingers around a DIMM.
- Never bend or flex the DIMM.

When installing a DIMM, observe the following:

- To align and seat the DIMM, use two fingers to hold the DIMM along the side edges.
- To seat the DIMM, use two fingers to apply gentle pressure along the top of the DIMM.

For more information, see the Hewlett Packard Enterprise website (<https://www.hpe.com/support/DIMM-20070214-CN>).

Installing a DIMM

Prerequisites

Before you perform this procedure, review the:

- [DIMM population information](#)
- [DIMM installation guidelines](#)

About this task



CAUTION

Do not install ×4 and ×8 DRAM widths in the same server. All memory installed in the server must be of the same type. Installing different DIMM types can cause the server to halt during BIOS initialization.



CAUTION

A discharge of static electricity from a finger or other conductor might damage system boards or other static-sensitive devices. To prevent damage, observe [antistatic precautions](#).

Procedure

1. If installed, [remove the front bezel](#).
2. [Power down the server](#).
3. Remove all power:
 - a. Disconnect each power cord from the power source.
 - b. Disconnect each power cord from the server.
4. Disconnect all peripheral cables from the server.
5. [Remove the server from the rack](#).
6. Place the server on a flat, level work surface.
7. [Remove the access panel](#).
8. [Remove the air baffle](#).
9. Install the DIMM:
 - a. Open the DIMM slot latches.
 - b. Align the notch on the bottom edge of the DIMM with the keyed surface of the DIMM slot, and then fully press the DIMM into the slot until the latches snap back into place.

The DIMM slots are structured to ensure proper installation. If you try to insert a DIMM but it does not fit easily into the slot, you might have positioned it incorrectly. Reverse the orientation of the DIMM and insert it again.

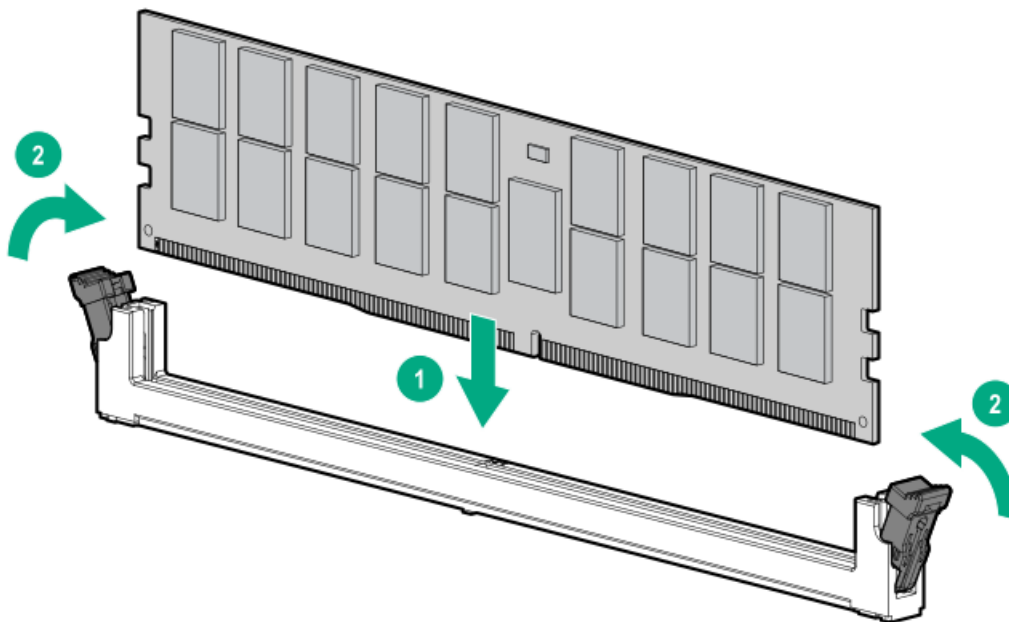

10. [Install the air baffle](#).
11. [Install the access panel](#).
12. [Install the server into the rack](#).
13. Connect all peripheral cables to the server.

14. Connect each power cord to the server.
15. Connect each power cord to the power source.
16. Power up the server.
17. If removed, install the front bezel.
18. To configure the memory settings:
 - a. From the boot screen, press **F9** to access the UEFI System Utilities.
 - b. From the System Utilities screen, select System Configuration > BIOS/Platform Configuration (RBSU) > Memory Options.

Results

The installation procedure is complete.

Stacking riser options

The server supports stacking riser options in the three-slot riser cage. Support on the PCIe slot 1 and slot 2 requires the stacking riser options.

Stacking risers:

- Support a stacking feature that allows multiple risers to be connected on top of each other.
- Feature a docking connector that supplies power.

The stacking risers have their assembled cables that connect to the NVMe ports on the system board.

For detailed information on riser option configurations, see the product QuickSpecs on the Hewlett Packard Enterprise website (<https://www.hpe.com/info/quickspecs>).

Subtopics

Installing the stacking risers

Installing the stacking risers

Prerequisites

- Before you perform this procedure, review the Riser slot numbering.
- To expand to two PCIe riser slots, the PCIe slot 2 riser option kit (P71989-B21) is required. The option kit includes:
 - Stacking riser (riser part number: P50365-001)
- To expand to three PCIe riser slots, the additional PCIe slot 1 riser option kit (P71991-B21) is required. The option kit includes:
 - Stacking riser (riser part number: P51472-001)
- Before you perform this procedure, make sure that you have a T-15 Torx screwdriver available.

About this task



CAUTION

A discharge of static electricity from a finger or other conductor might damage system boards or other static-sensitive devices. To prevent damage, observe antistatic precautions.

Procedure

1. If installed, remove the front bezel.
2. Power down the server.
3. Remove all power:
 - a. Disconnect each power cord from the power source.
 - b. Disconnect each power cord from the server.
4. Disconnect all peripheral cables from the server.
5. Remove the server from the rack.
6. Place the server on a flat, level work surface.
7. Remove the access panel.
8. Remove the air baffle.
9. Remove the three-slot riser cage.
10. Remove the base riser from the riser cage.

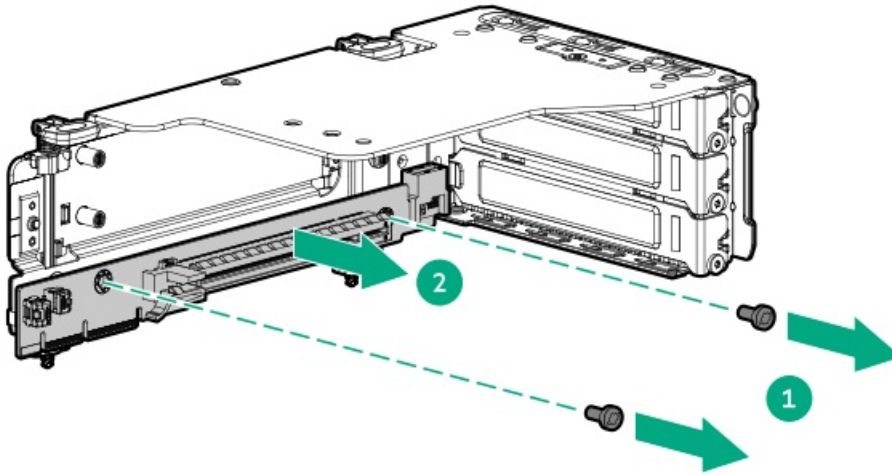

Installing the slot 2 stacking riser

11. Connect the slot 2 stacking riser to the base riser.

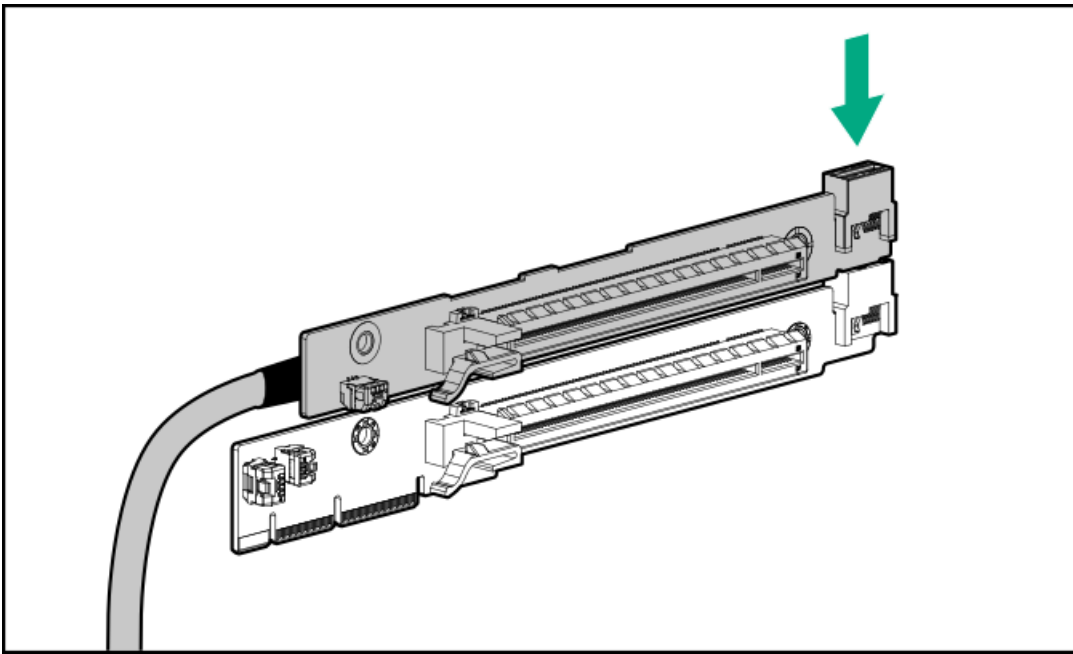

12. Install the risers on the riser cage.

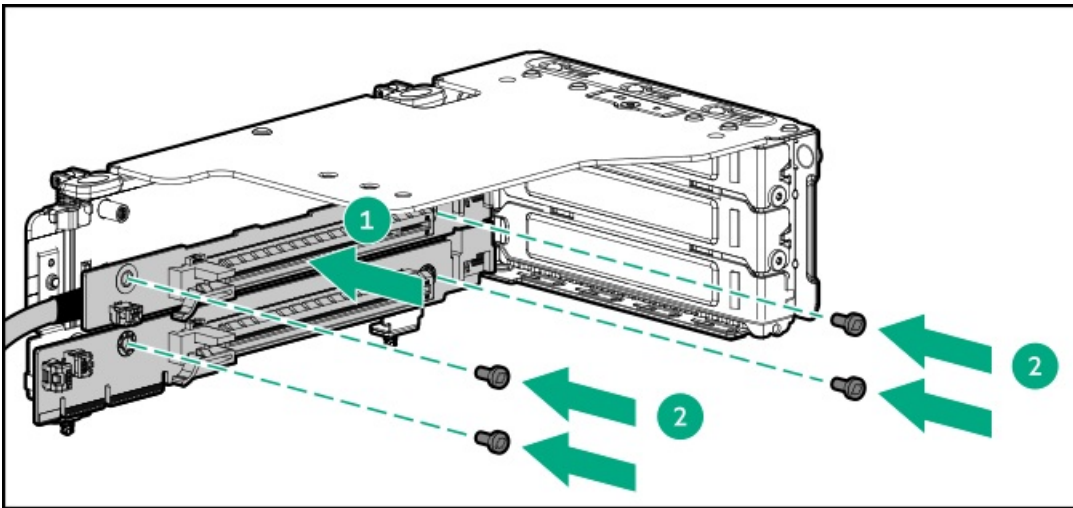

Installing the slot 1 and slot 2 stacking risers
13. Connect the slot 1 stacking riser to the slot 2 stacking riser.



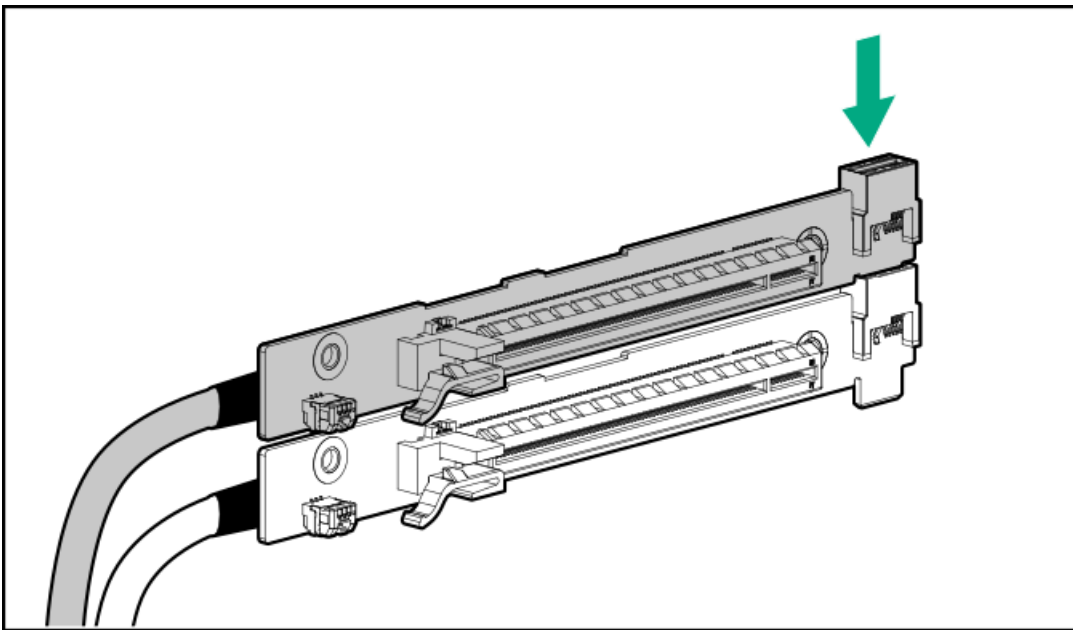

14. Connect the stacking risers to the base riser.

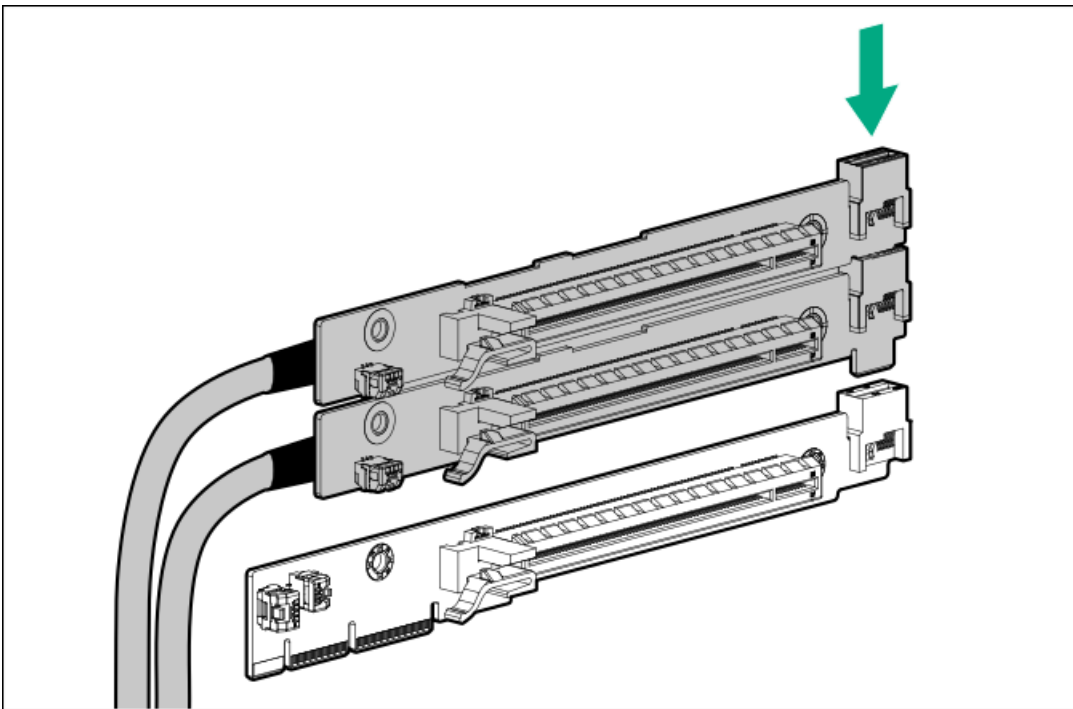

15. Install the risers on the riser cage.

For clarity, the cables of the stacking risers are not shown in the following image.

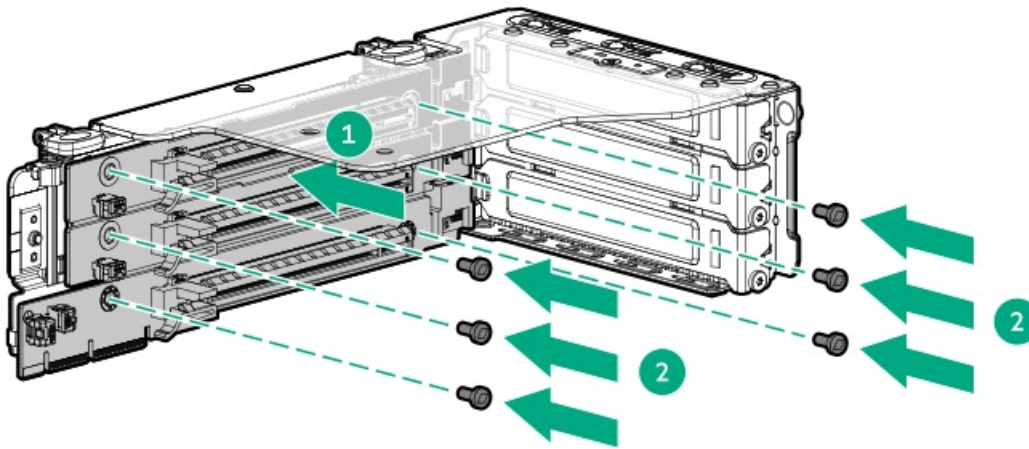

16. Connect the stacking riser cables to the system board .

If the cables are not connected correctly, the system will not power on.

17. (Optional) Install the expansion card.
18. Install the three-slot riser cage.
19. Install the air baffle.
20. Install the access panel.
21. Install the server into the rack.
22. Connect all peripheral cables to the server.
23. Connect each power cord to the server.
24. Connect each power cord to the power source.
25. Power up the server.
26. If removed, install the front bezel.

Results

The installation procedure is complete.

Storage controller options

This server has no embedded software RAID support. Direct attached SATA drives operate in AHCI mode.

To support hardware RAID, install a HPE MR type-o or type-p Gen11 controller.

When a tri-mode storage controller option is used together with a U.3 drive backplane, the system will support mixed drive configuration.

Subtopics

[Preparing the server for storage controller installation](#)

[Installing a type-p storage controller on the three-slot riser cage](#)

[Installing a type-o storage controller](#)

Preparing the server for storage controller installation

Prerequisites

Before beginning this procedure, download the Service Pack for ProLiant (SPP) from the Hewlett Packard Enterprise website (<https://www.hpe.com/servers/spp/download>).

Procedure

1. If the server was previously configured:
 - a. Back up data on the system.
 - b. Close all applications.
 - c. Ensure that users are logged off and that all tasks are completed on the server.



CAUTION

In systems that use external data storage, be sure that the server is the first unit to be powered down and the last to be powered back up. Taking this precaution ensures that the system does not erroneously mark the drives as failed when the server is powered up.

2. If the server firmware is not the latest revision, update the firmware.
3. If the new controller is the new boot device, install the controller drivers.

Installing a type-p storage controller on the three-slot riser cage

Prerequisites

- To enable the flash-backed write cache (FBWC) feature of a storage controller option, install an energy pack.
For more information on the controller caching feature, see the controller QuickSpecs on the Hewlett Packard Enterprise website (<https://www.hpe.com/info/quickspecs>).
- If installing a type-p controller in PCIe slot 1 or slot 2, make sure that the stacking riser options are installed.
- Before you perform this procedure, make sure that you have the following items available:
 - Compatible controller cable
 - T-10 Torx screwdriver

About this task



CAUTION

A discharge of static electricity from a finger or other conductor might damage system boards or other static-sensitive devices. To prevent damage, observe antistatic precautions.



CAUTION

To prevent improper cooling and thermal damage, do not operate the server unless all PCIe slots have either a riser slot blank or an expansion card installed.

Procedure

1. If installed, remove the front bezel.
2. Power down the server.
3. Remove all power:

- a. Disconnect each power cord from the power source.
- b. Disconnect each power cord from the server.
4. Disconnect all peripheral cables from the server.
5. Remove the server from the rack.
6. Place the server on a flat, level work surface.
7. Remove the access panel.
8. Remove the air baffle.
9. If stacking risers are installed, disconnect the stacking riser cables from the system board.
10. Remove the three-slot riser cage.
11. Install the type-p controller:
 - a. Remove the riser slot blank.

For clarity, the cables of the stacking risers are not shown in the following image.

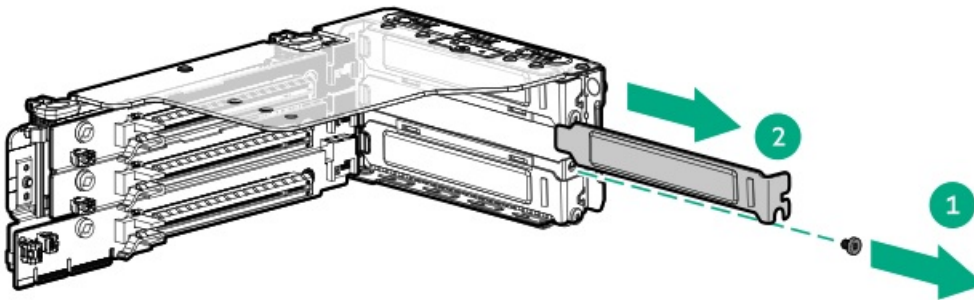

- b. Install the storage controller.

Make sure that the storage controller is seated firmly in the slot.

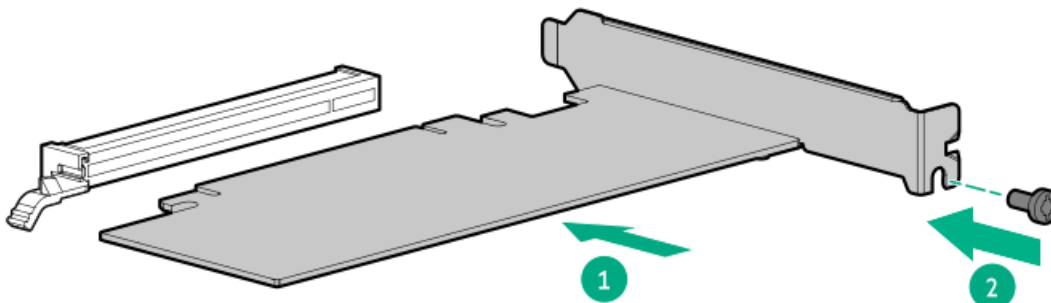

12. Install the three-slot riser cage.
13. If disconnected, connect the stacking riser cables to the system board.
14. Cable the type-p storage controller.
15. To enable the FBWC feature of the storage controller, install an energy pack.

16. [Install the air baffle.](#)
17. [Install the access panel.](#)
18. [Install the server into the rack.](#)
19. Connect all peripheral cables to the server.
20. Connect each power cord to the server.
21. Connect each power cord to the power source.
22. [Power up the server.](#)
23. If removed, [install the front bezel.](#)
24. To configure the controller, see the [relevant storage controller guide.](#)

Results

The installation procedure is complete.

Installing a type-o storage controller

Prerequisites

Before you perform this procedure, make sure that you have the following items available:

- [Compatible controller cable](#)
- T-10 Torx screwdriver

About this task

This server supports type-o storage controller installation in the OCP slot 21.



CAUTION

A discharge of static electricity from a finger or other conductor might damage system boards or other static-sensitive devices. To prevent damage, observe [antistatic precautions](#).



CAUTION

The port blank provides EMI shielding and helps maintain proper thermal status inside the server. Do not operate the server when a port blank is removed without the corresponding I/O port option installed.

Procedure

1. If installed, [remove the front bezel.](#)
2. [Power down the server.](#)
3. Remove all power:
 - a. Disconnect each power cord from the power source.
 - b. Disconnect each power cord from the server.
4. Disconnect all peripheral cables from the server.
5. [Remove the server from the rack.](#)
6. Place the server on a flat, level work surface.

7. Remove the access panel.
8. Remove the air baffle.
9. If stacking risers are installed, disconnect the stacking riser cables from the system board.
10. Remove the three-slot riser cage.
11. Remove the OCP slot 21 blank:
 - a. Remove the blank screw.
 - b. Use a plastic spudger to pry the top side of the blank from the chassis.
 - c. Remove the blank.

Retain the screw and blank for future use.

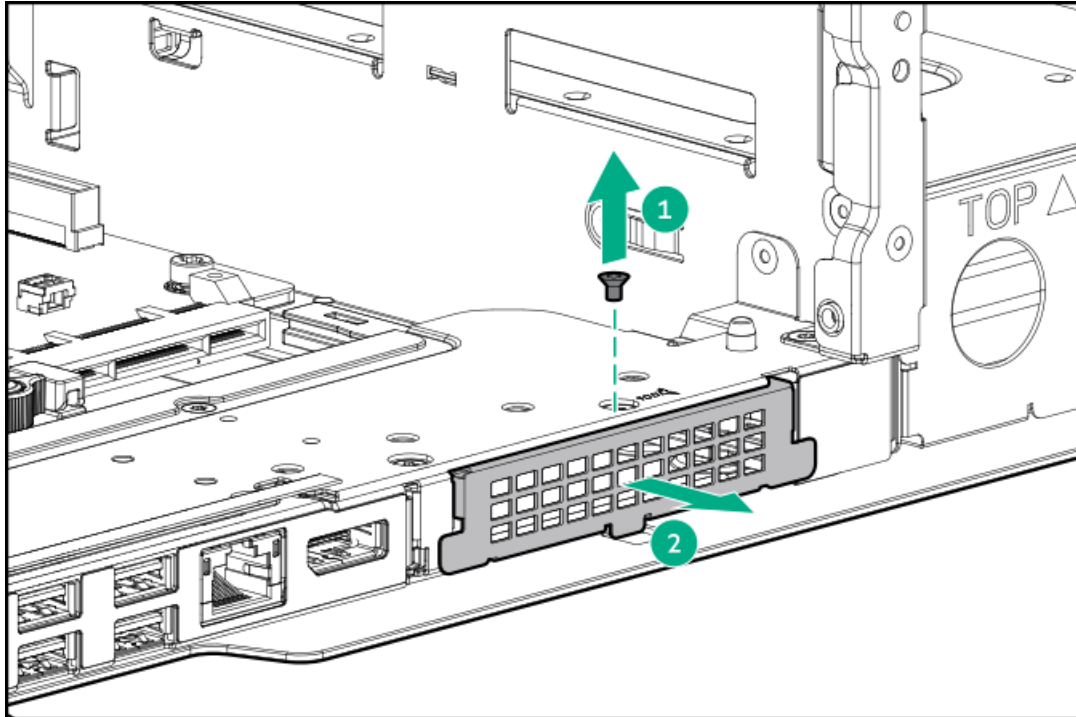

12. Install the type-o storage controller:
 - a. Rotate the locking pin to the open (vertical) position.
 - b. Slide the controller into the bay until it clicks into place.
Make sure that the controller is seated firmly in the slot.
 - c. Rotate the locking pin to the close (horizontal) position.

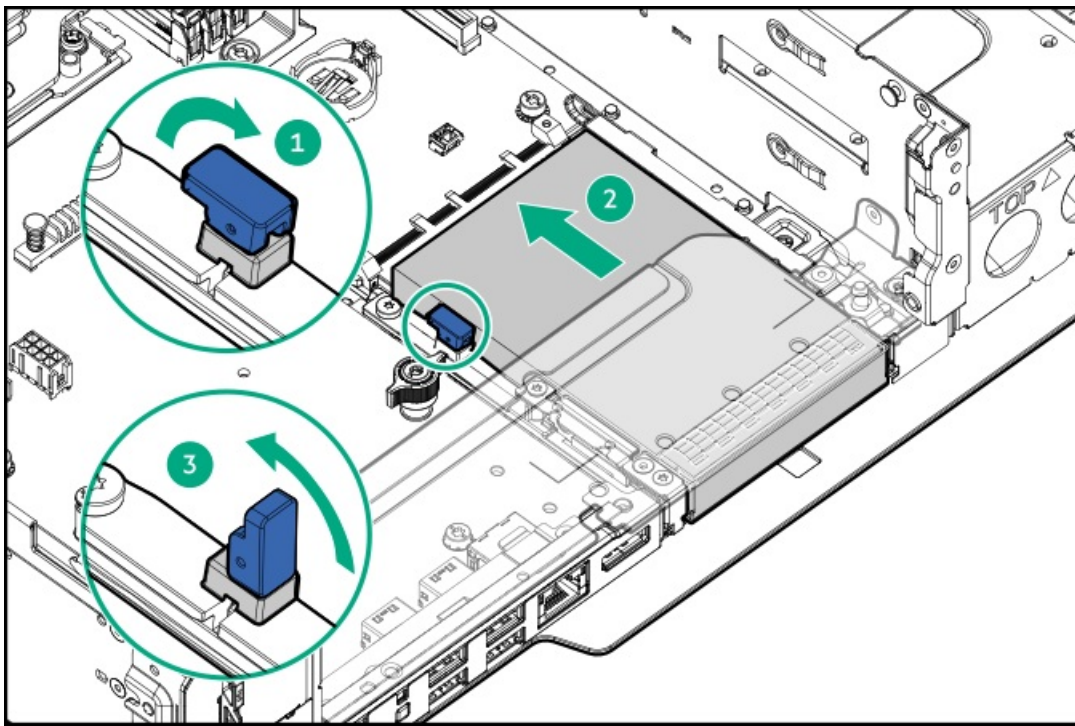

13. Cable the type-o storage controller.
14. Install the three-slot riser cage.
15. If disconnected, connect the stacking riser cables to the system board.
16. Install the air baffle.
17. Install the access panel.
18. Install the server into the rack.
19. Connect all peripheral cables to the server.
20. Connect each power cord to the server.
21. Connect each power cord to the power source.
22. Power up the server.
23. If removed, install the front bezel.
24. To configure the controller, see the relevant storage controller guide.

Results

The installation procedure is complete.

Energy pack option

Hewlett Packard Enterprise offers the HPE Smart Storage Battery as a centralized backup power source options to back up write cache content on the controllers in an unplanned server power outage.

After it is installed, the status of the energy pack appears in HPE iLO. For more information, see the iLO user guide on the Hewlett Packard Enterprise website (<https://www.hpe.com/support/hpeilodocs-quicklinks>).

Subtopics

HPE Smart Storage Battery

The HPE Smart Storage Battery supports both HPE SR and MR storage controllers.

A single 96 W battery can support up to 24 devices.

After the battery is installed, it might take up to two hours to charge. Controller features requiring backup power are not re-enabled until the battery is capable of supporting the backup power.

This server supports the 96 W HPE Smart Storage Battery with the 145 mm cable.

For more information, see HPE Smart Storage Batteries and Hybrid Capacitors QuickSpecs:

https://www.hpe.com/psnow/doc/a00028553enw.pdf?jumpid=in_pdp-psnow-qs

Installing an energy pack

Prerequisites

Make sure that you have the storage controller backup power cable (ships with the storage controller) available.

About this task



CAUTION

A discharge of static electricity from a finger or other conductor might damage system boards or other static-sensitive devices. To prevent damage, observe [antistatic precautions](#).

Procedure

1. If installed, remove the front bezel.
2. Power down the server.
3. Remove all power:
 - a. Disconnect each power cord from the power source.
 - b. Disconnect each power cord from the server.
4. Disconnect all peripheral cables from the server.
5. Remove the server from the rack.
6. Place the server on a flat, level work surface.
7. Remove the access panel.
8. Remove the air baffle.
9. To install the energy pack in the retention latch:
 - a. Attach one end of the energy pack on the chassis.
 - b. Push the energy pack down from the other end.
Make sure that the energy pack is locked in the retention latch.
 - c. Connect the energy pack cable to the system board.

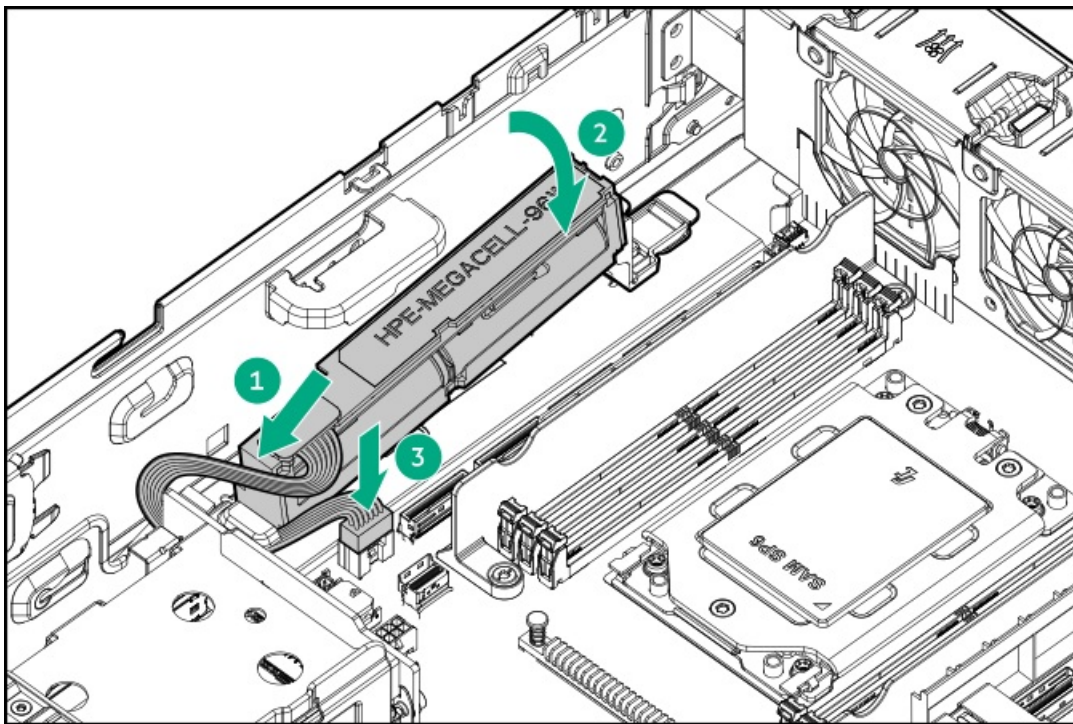

10. Connect the storage backup power cable
11. Install the air baffle.
12. Install the access panel.
13. Install the server into the rack.
14. Connect all peripheral cables to the server.
15. Connect each power cord to the server.
16. Connect each power cord to the power source.
17. Power up the server.
18. If removed, install the front bezel.

Results

The installation procedure is complete.

Expansion card options

The server supports the installation of full-height, half-length, and half-height, half-length PCIe expansion / add-in (AIC) cards such as:

- HPE type-p storage controller
- Ethernet adapter
- GPU (workload, computational, or graphics GPU)

For more information on the expansion options validated for this server, see the server QuickSpecs on the Hewlett Packard Enterprise website:

<https://www.hpe.com/info/quickspecs>

Subtopics



GPU options

GPU installation guidelines

Installing an expansion card on the base riser

Installing an expansion card on the stacking riser

GPU options

This server supports various GPU options to meet your computational and graphics workload requirements. For a list of supported GPU models, see the server QuickSpecs on the Hewlett Packard Enterprise website (<https://www.hpe.com/info/quickspecs>).

- PCIe workload GPUs—These options are PCIe card-based, direct-attach solutions that use solid-state storage technology directly on the PCI bus to boost I/O performance and reduce latency to scale in line with your processing requirements.
- Computational and graphics GPUs—These options deliver accelerated compute performance for a range of deep learning, high-performance computing (HPC), and graphics-intensive applications.

GPU installation guidelines

- This server does not support the installation of different GPU models in the same system.
- The limited operating inlet ambient temperatures required for GPUs vary based on the model and the server drive configuration. For more information, see the server QuickSpecs on the Hewlett Packard Enterprise website (<https://www.hpe.com/info/quickspecs>).
- If installing up to three NVIDIA L4 PCIe GPUs in the same system, the following stacking riser option kits are required:
 - PCIe slot 1 stacking riser (P71991-B21)
 - PCIe slot 2 stacking riser (P71989-B21)



IMPORTANT

Workloads for high performance GPUs with passive cooling can cause the fans to operate at high speeds to maintain optimum system cooling. Hewlett Packard Enterprise does not recommend installing GPUs with passive cooling in or near a site where there is a reasonable expectation for a quiet environment.

Installing an expansion card on the base riser

Prerequisites

- If you are installing a GPU, review the [GPU installation guidelines](#).
- Before you perform this procedure, make sure that you have a T-10 Torx screwdriver available.

About this task



CAUTION

A discharge of static electricity from a finger or other conductor might damage system boards or other static-sensitive devices. To prevent damage, observe [antistatic precautions](#).



CAUTION

To prevent improper cooling and thermal damage, do not operate the server unless all PCIe slots have either a riser slot blank or an expansion card installed.

Procedure

1. If installed, remove the front bezel.
2. Power down the server.
3. Remove all power:
 - a. Disconnect each power cord from the power source.
 - b. Disconnect each power cord from the server.
4. Disconnect all peripheral cables from the server.
5. Remove the server from the rack.
6. Place the server on a flat, level work surface.
7. Remove the access panel.
8. Remove the air baffle.
9. If stacking risers are installed, disconnect the stacking riser cables from the system board.
10. Remove the three-slot riser cage.
11. Install the expansion card:
 - a. Remove the riser slot blank.

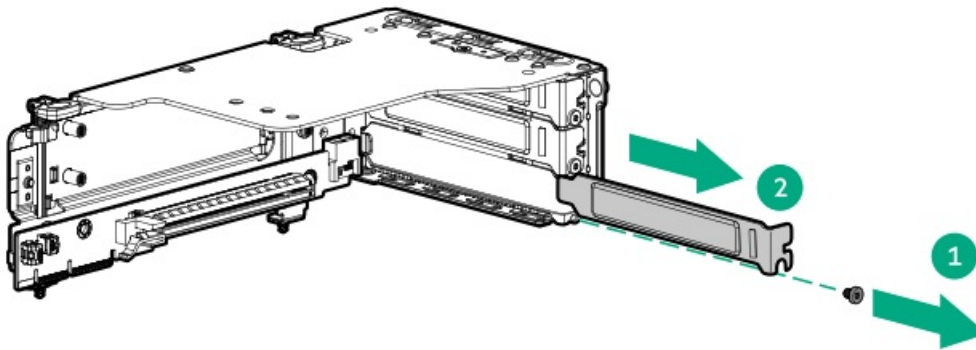

- b. Install the expansion card.

Make sure that the expansion card is seated firmly in the slot.

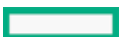

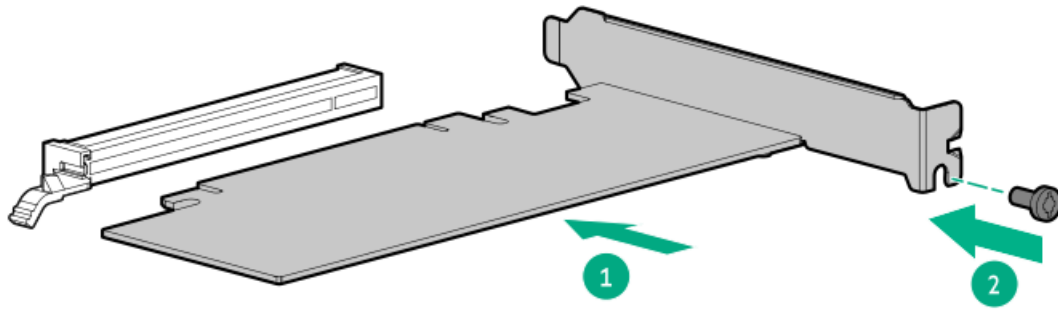

12. [Install the three-slot riser cage.](#)
13. If disconnected, [connect the stacking riser cables](#) to the system board.
14. [Install the air baffle.](#)
15. [Install the access panel.](#)
16. [Install the server into the rack.](#)
17. Connect all peripheral cables to the server.
18. Connect each power cord to the server.
19. Connect each power cord to the power source.
20. [Power up the server.](#)
21. If removed, [install the front bezel.](#)

Results

The installation procedure is complete.

Installing an expansion card on the stacking riser

Prerequisites

- Before you perform this procedure, review the following:
 - If installing a GPU:
 - [GPU installation guidelines](#)
 - [GPU numbering](#)
 - [Riser slot numbering](#)
- [Stacking riser options](#) are installed—This is required if installing the card in PCIe slot 1 or 2.
- Before you perform this procedure, make sure that you have a T-10 Torx screwdriver available.

About this task



CAUTION

To prevent improper cooling and thermal damage, do not operate the server unless all PCIe slots have either a riser slot blank or an expansion card installed.



CAUTION

A discharge of static electricity from a finger or other conductor might damage system boards or other static-sensitive devices. To prevent damage, observe antistatic precautions.

Procedure

1. If installed, remove the front bezel.
2. Power down the server.
3. Remove all power:
 - a. Disconnect each power cord from the power source.
 - b. Disconnect each power cord from the server.
4. Disconnect all peripheral cables from the server.
5. Remove the server from the rack.
6. Place the server on a flat, level work surface.
7. Remove the access panel.
8. Remove the air baffle.
9. Remove the three-slot riser cage.
10. Place the riser cage on top of the power supply bay with the riser slots facing up.

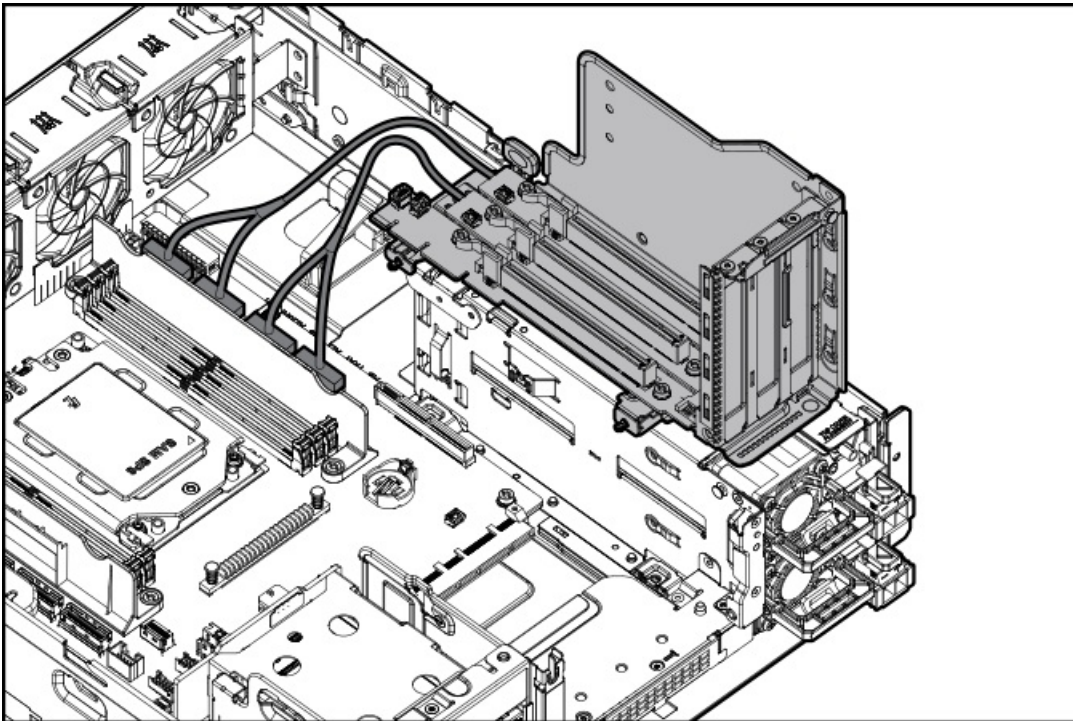

11. Install the expansion card:
 - a. Remove the riser slot blank.

For clarity, the cables of the stacking risers are not shown in the following image.



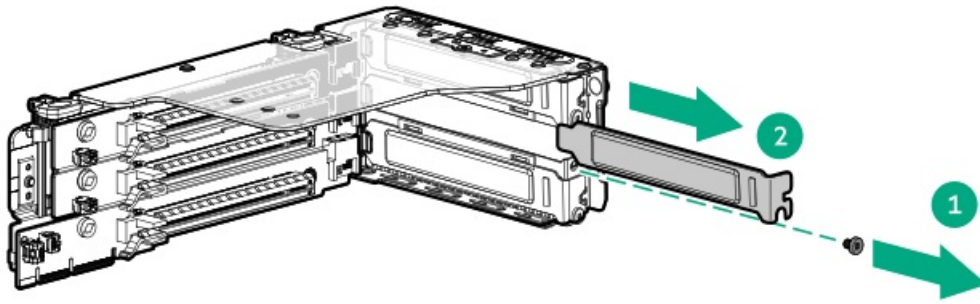

b. Install the expansion card.

Make sure that the expansion card is seated firmly in the slot.

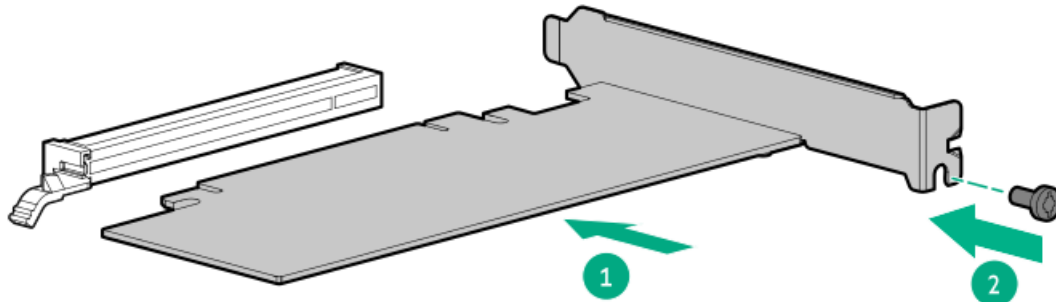

12. Install the three-slot riser cage.
13. Install the air baffle.
14. Install the access panel.
15. Install the server into the rack.
16. Connect all peripheral cables to the server.
17. Connect each power cord to the server.
18. Connect each power cord to the power source.
19. Power up the server.
20. If removed, install the front bezel.

Results

The installation procedure is complete.

HPE NS204i-u Boot Device option

The server supports the NS204i-u boot device through the NS204i-u enablement option kit (P71992-B21). For more information, see the product QuickSpecs on the HPE ProLiant DL145 Gen11 Server website:

<https://www.hpe.com/info/quickspecs>

Note the following information about the HPE NS204i-u Boot Device option:

- The HPE NS204i-u Gen11 NVMe Hot Plug Boot Optimized Storage Device is a PCIe5 custom form factor module that includes two hot-pluggable 2280 M.2 NVMe SSDs.
- This boot device enables the deployed OS to be mirrored through a dedicated hardware RAID 1.
- The boot device auto-creates a RAID1 volume during boot. This means the boot device does not require further RAID configuration.
- This boot device is compatible with the following native OS:
 - Windows
 - Linux
 - VMware
- This boot device uses native inbox OS NVMe drivers.

Subtopics

[Installing the HPE NS204i-u Boot Device on the front panel](#)

Installing the HPE NS204i-u Boot Device on the front panel

Prerequisites

- Make sure that the server is updated with the latest operating system firmware and drivers.
- [Identify the HPE NS204i-u Boot Device components.](#)
- Before you perform this procedure, make sure that you have the following items available:
 - [NS204i-u enablement option kit](#)
 - T-10 Torx screwdriver
 - Phillips No. 1 screwdriver—This tool is required only if the M.2 SSDs are not preinstalled on the boot device carriers.

About this task



CAUTION

A discharge of static electricity from a finger or other conductor might damage system boards or other static-sensitive devices. To prevent damage, observe [antistatic precautions](#).



CAUTION

To prevent improper cooling and thermal damage, do not operate the server unless all bays are populated with either a component or a blank.



IMPORTANT

To ensure proper RAID 1 configuration, verify that the boot device SSDs are the same part number. Mixed SSD models are not supported.

Procedure

Installing drives onto the boot device

1. Remove the boot device carrier:
 - a. Press and hold the carrier latch.



- b. Pivot the latch to open.
- c. Slide the carrier out from the boot device cage.

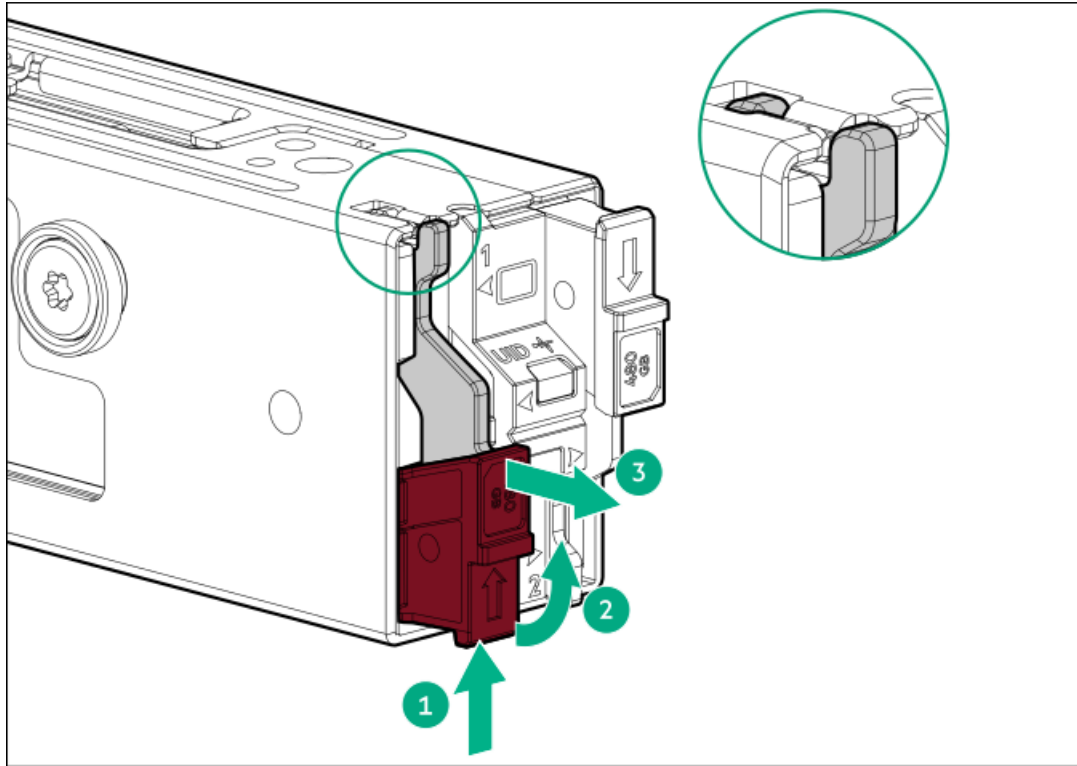

2. Install the SSD on the boot device carrier:

- a. Remove the SSD mounting screw.

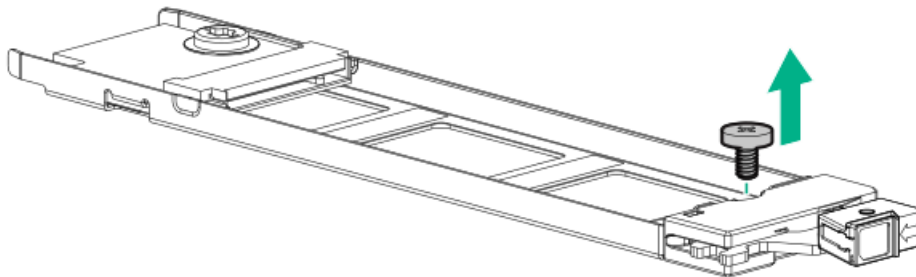

- b. Insert the SSD into the M.2 slot at a 45° angle.
- c. Carefully press the SSD down to the horizontal position.
- d. Install the SSD mounting screw.



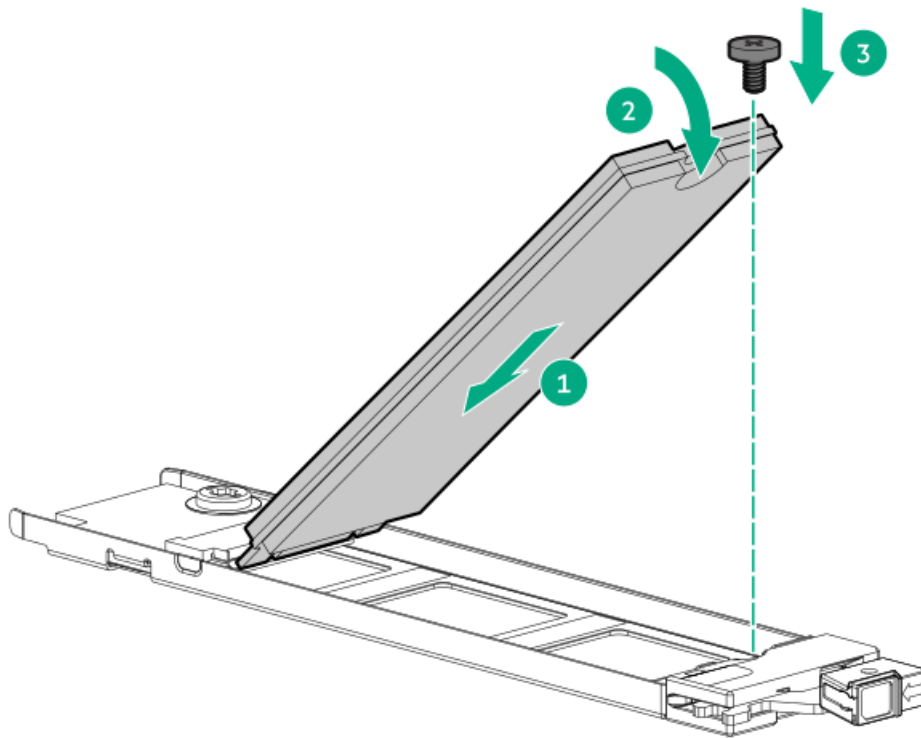

3. Install the boot device carriers:

- a. If closed, pivot the carrier latch to open.
- b. Slide the carrier into the boot device cage.
- c. Pivot the latch to close.

Make sure that the carrier latch is locked on the boot device cage.

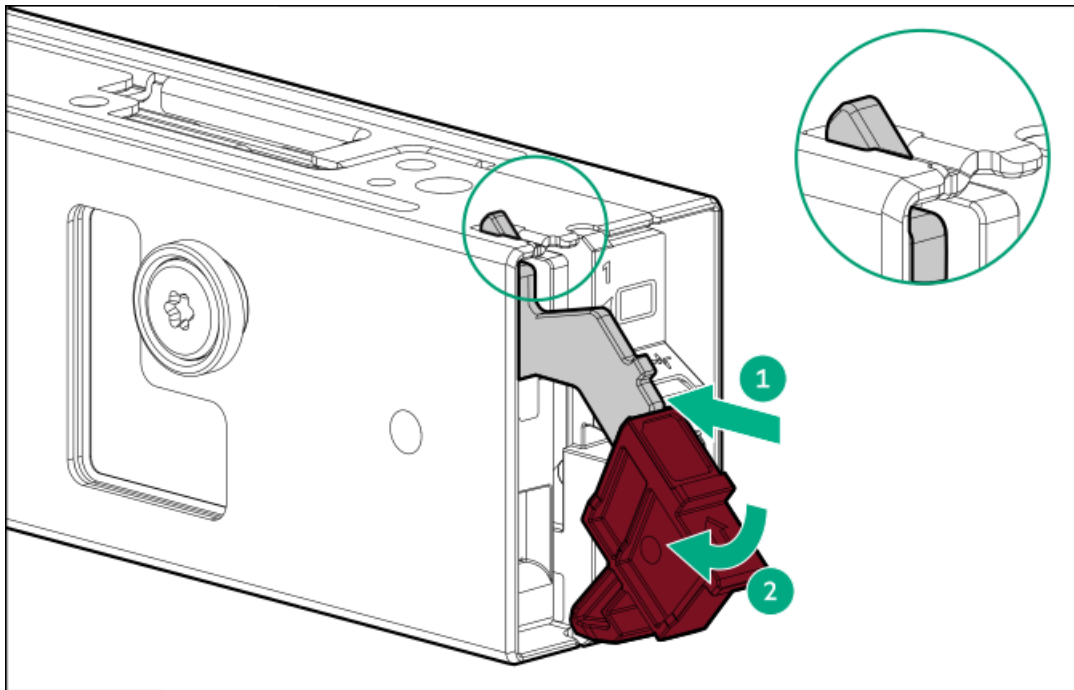

Installing the boot device

- 4. If installed, remove the front bezel.
- 5. Power down the server.
- 6. Remove all power:



- a. Disconnect each power cord from the power source.
- b. Disconnect each power cord from the server.
7. Disconnect all peripheral cables from the server.
8. Remove the server from the rack.
9. Place the server on a flat, level work surface.
10. Remove the access panel.
11. Remove the air baffle.
12. Install the boot device on the boot device bracket:
 - a. Insert the boot device into the bracket until the notch on the bracket is engaged with the spool on the boot device.
 - b. Install the screws.

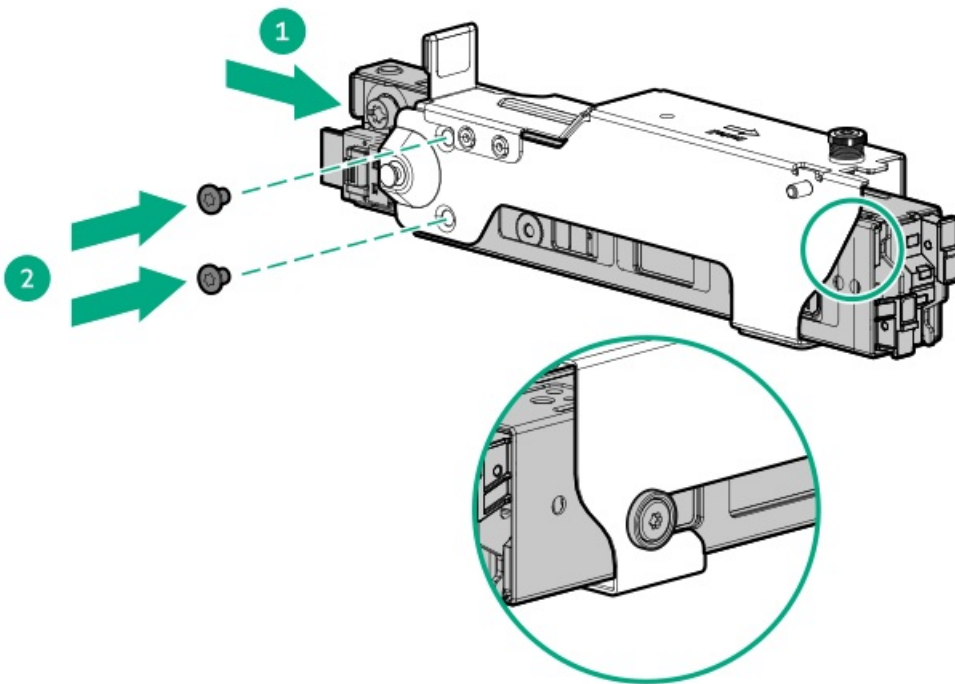

13. Remove the screw and spool from the boot device cage.

Retain the screw and spool for future use.

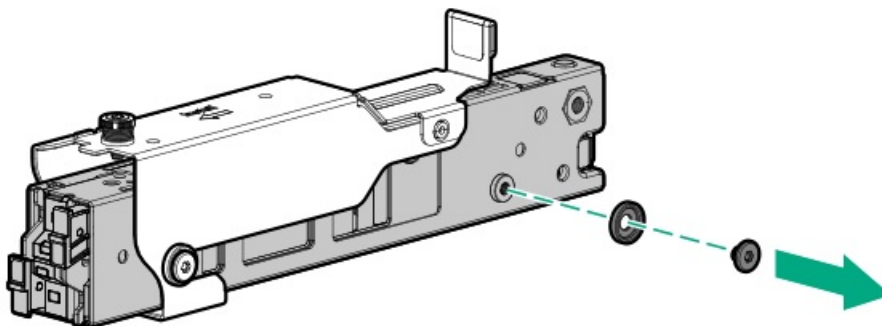

14. Remove the boot device blank from the front panel.



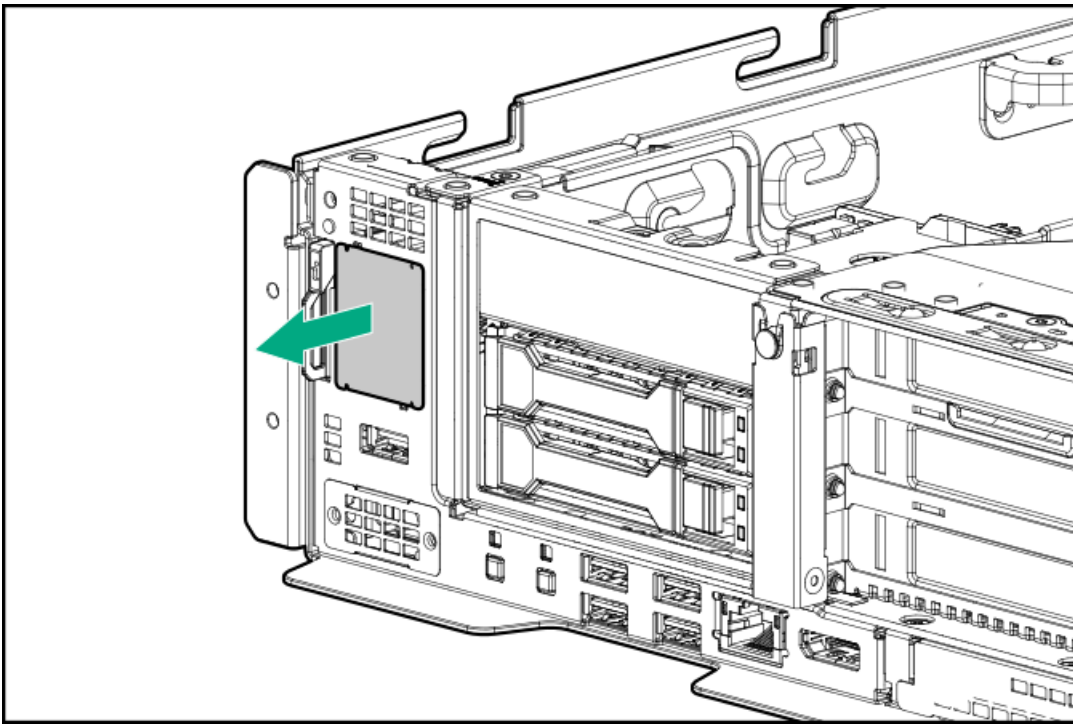

15. Install the boot device:

- a. Insert the boot device into the boot device slot at a 45° angle.
- b. Slide the boot device down to the horizontal position until the spool on the bracket is fully engaged with the notch on the chassis.
- c. Tighten the thumbscrew.

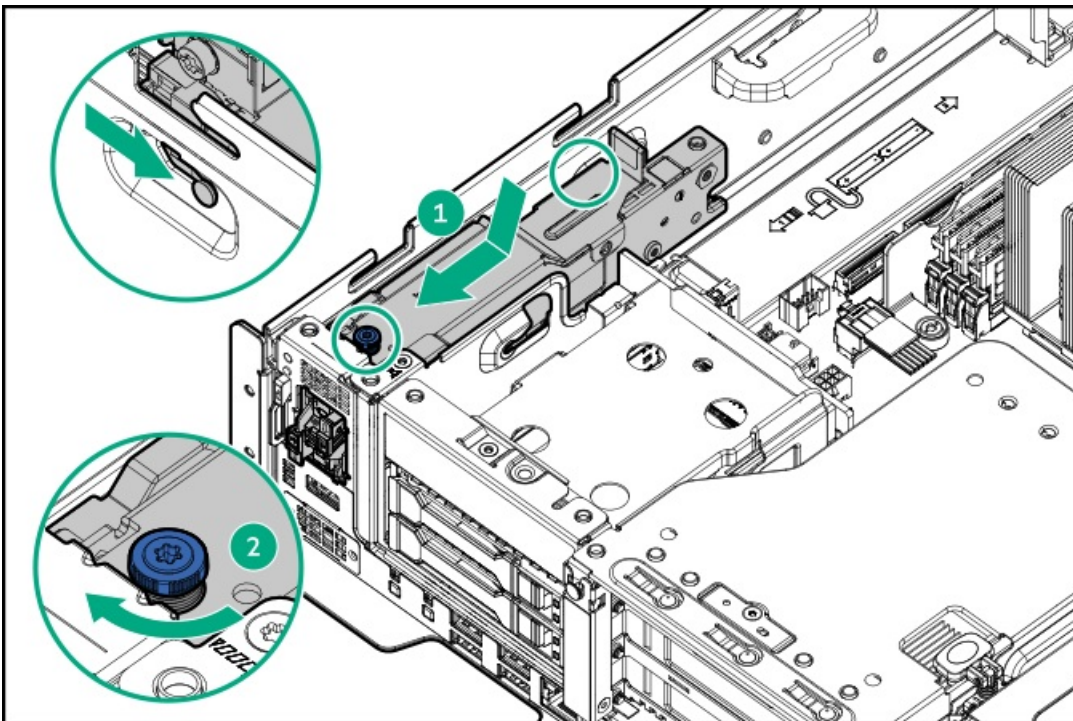

16. Connect the boot device signal and power cables to the system board.

17. Install the air baffle.

18. Install the access panel.

19. Install the server into the rack.

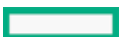

20. Connect all peripheral cables to the server.
21. Connect each power cord to the server.
22. Connect each power cord to the power source.
23. Power up the server.
24. If removed, install the front bezel.

Results

The installation procedure is complete.

OCP NIC 3.0 adapter option

The server supports SFF dual-port and quad-port OCP NIC 3.0 adapter options with various interfaces and advanced interconnect features for high-bandwidth applications.

Subtopics

[Installing an OCP NIC 3.0 adapter](#)

Installing an OCP NIC 3.0 adapter

Prerequisites

Before you perform this procedure, make sure that you have the following items available:

- T-10 Torx screwdriver
- Spudger or any small prying tool

About this task



CAUTION

To prevent improper cooling and thermal damage, do not operate the server unless all PCIe slots have either a riser slot blank or an expansion card installed.



CAUTION

A discharge of static electricity from a finger or other conductor might damage system boards or other static-sensitive devices. To prevent damage, observe antistatic precautions.

Procedure

1. If installed, remove the front bezel.
2. Power down the server.
3. Remove all power:
 - a. Disconnect each power cord from the power source.
 - b. Disconnect each power cord from the server.
4. Disconnect all peripheral cables from the server.

5. Remove the server from the rack.
6. Place the server on a flat, level work surface.
7. Remove the access panel.
8. Remove the air baffle.
9. If stacking risers are installed, disconnect the stacking riser cables from the system board.
10. Remove the three-slot riser cage.
11. Remove the OCP 3.0 NIC adapter blank:
 - a. Remove the blank screw.
 - b. Use a plastic spudger to pry the top side of the blank from the chassis.
 - c. Remove the blank.

Retain the blank for future use.

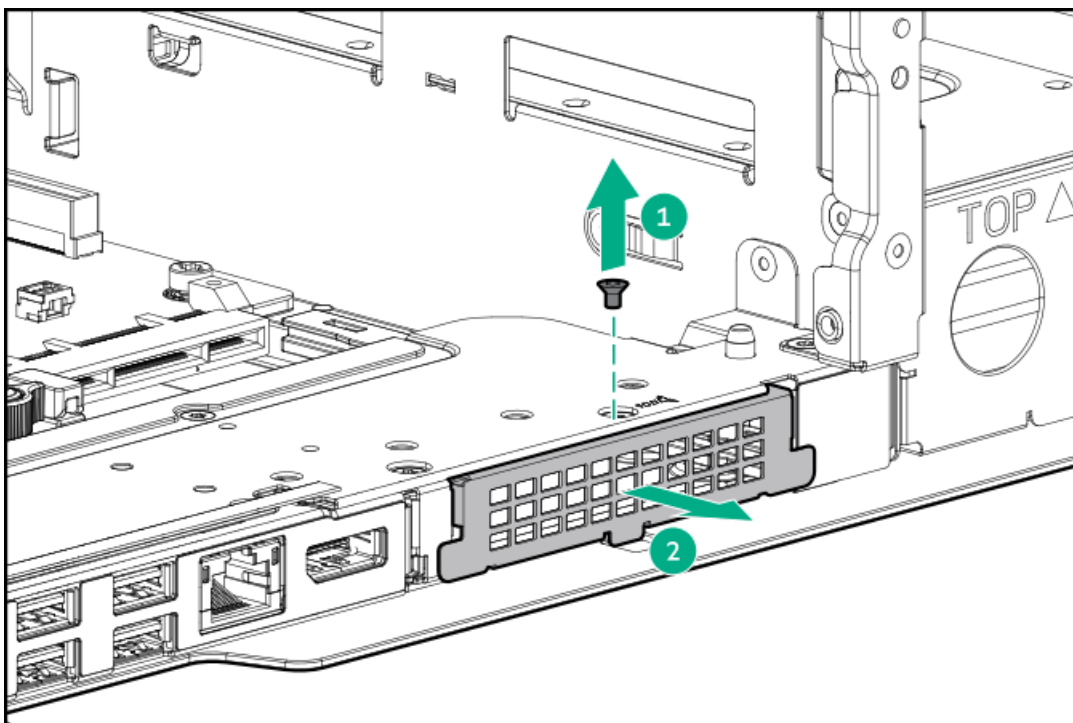

12. Install the OCP NIC 3.0 adapter:
 - a. Rotate the locking pin to the open (vertical) position.
 - b. Slide the adapter into the bay until it clicks into place.
Make sure that the card is seated firmly in the slot.
 - c. Rotate the locking pin to the close (horizontal) position.

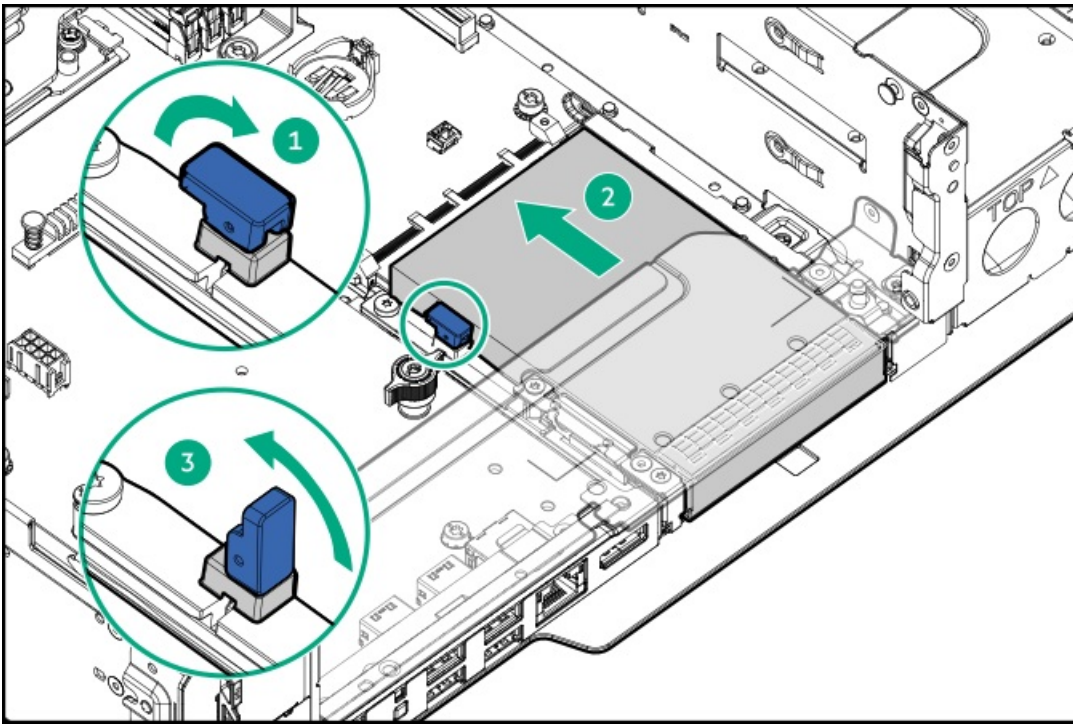

13. Install the three-slot riser cage.
14. If disconnected, connect the stacking riser cables to the system board.
15. Install the air baffle.
16. Install the access panel.
17. Install the server into the rack.
18. Connect all peripheral cables to the server.
19. Connect each power cord to the server.
20. Connect each power cord to the power source.
21. Power up the server.
22. If removed, install the front bezel.

Results

The installation procedure is complete.

Chassis intrusion detection switch option

The chassis intrusion detection switch enables iLO to record an event in the Integrated Management Log (IML) whenever the access panel is physically opened or removed. An alert is also sent to the BIOS whenever a chassis intrusion is detected. The chassis intrusion detection occurs as long as the server is plugged in, regardless of whether the server is powered on or off.

Subtopics

[Installing the chassis intrusion detection switch](#)

Installing the chassis intrusion detection switch

About this task



CAUTION

A discharge of static electricity from a finger or other conductor might damage system boards or other static-sensitive devices. To prevent damage, observe [antistatic precautions](#).

Procedure

1. If installed, [remove the front bezel](#).
2. [Power down the server](#).
3. Remove all power:
 - a. Disconnect each power cord from the power source.
 - b. Disconnect each power cord from the server.
4. Disconnect all peripheral cables from the server.
5. [Remove the server from the rack](#).
6. Place the server on a flat, level work surface.
7. [Remove the access panel](#).
8. [Remove the air baffle](#).
9. Install the chassis intrusion detection switch:
 - a. Insert the switch tab into the chassis slot until the switch clicks into place.
 - b. Connect the [switch cable](#) to the system board.

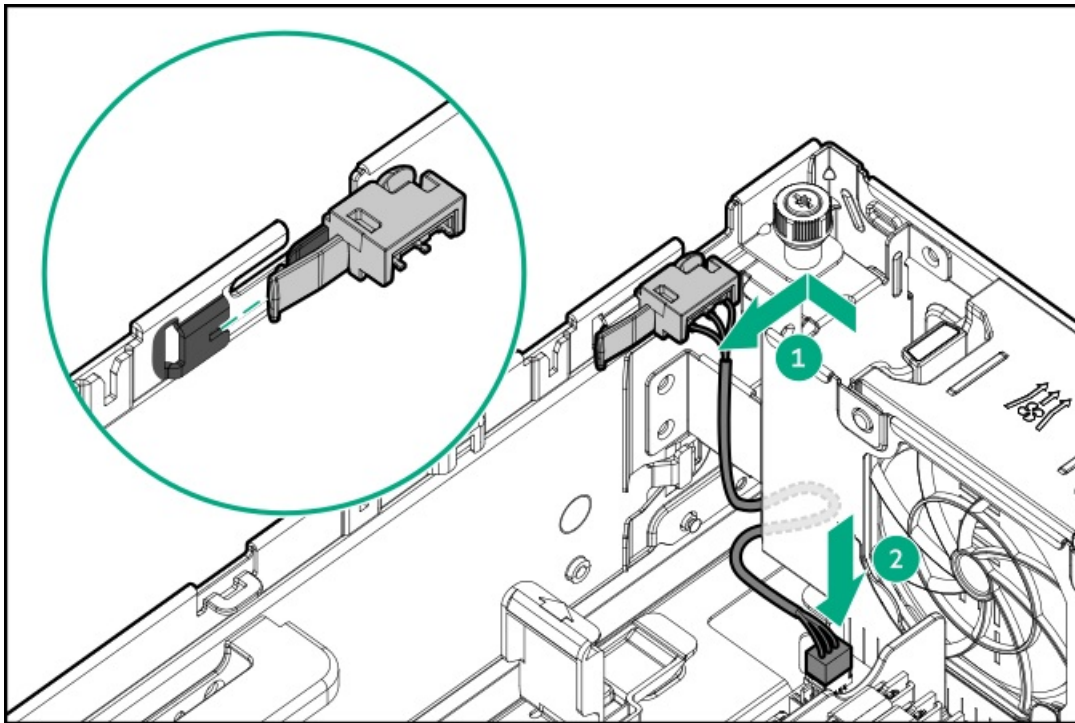

10. [Install the air baffle](#).
11. [Install the access panel](#).
12. [Install the server into the rack](#).
13. Connect all peripheral cables to the server.

14. Connect each power cord to the server.
15. Connect each power cord to the power source.
16. Power up the server.
17. If removed, install the front bezel.

Results

The installation procedure is complete.

Serial port option

Install the serial port option to enable communication to physical serial devices. You can also use the serial connection to remotely access the system BIOS and view POST error messages.

Subtopics

[Installing the RJ45-serial port cable option](#)

Installing the RJ45-serial port cable option

Prerequisites

Before you perform this procedure, make sure that you have a T-10 Torx screwdriver available.

About this task



CAUTION

A discharge of static electricity from a finger or other conductor might damage system boards or other static-sensitive devices. To prevent damage, observe antistatic precautions.



CAUTION

The port blank provides EMI shielding and helps maintain proper thermal status inside the server. Do not operate the server when a port blank is removed without the corresponding I/O port option installed.

Procedure

1. If installed, remove the front bezel.
2. Power down the server.
3. Remove all power:
 - a. Disconnect each power cord from the power source.
 - b. Disconnect each power cord from the server.
4. Disconnect all peripheral cables from the server.
5. Remove the server from the rack.
6. Place the server on a flat, level work surface.
7. Remove the access panel.

8. Remove the air baffle.
9. If the boot device is installed, do the following:
 - a. Disconnect the boot device power and signal cables.
 - b. Remove the boot device and boot device bracket.

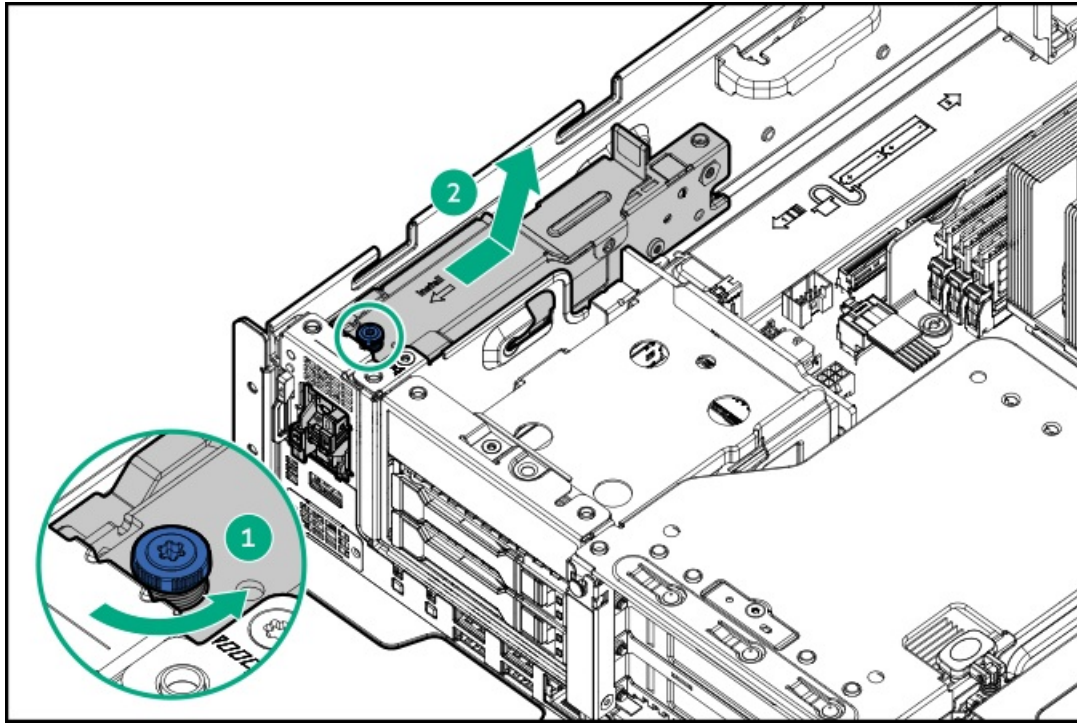

10. Remove the three-slot riser cage.
11. Remove the drive base cage.
12. Remove the serial port blank.

Retain the blank for future use.

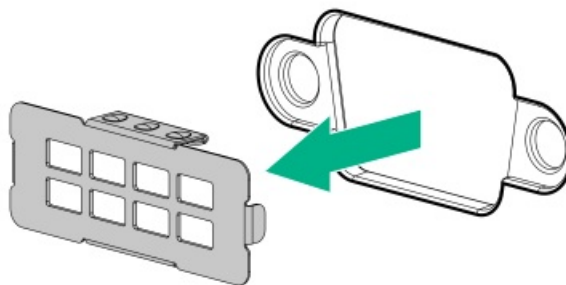

13. Install the RJ45-serial port cable:
 - a. Insert the RJ45-serial port cable connector into the front panel opening.
Make sure on the connector end, the side with the stamped logo is facing up.
 - b. Install the screws.



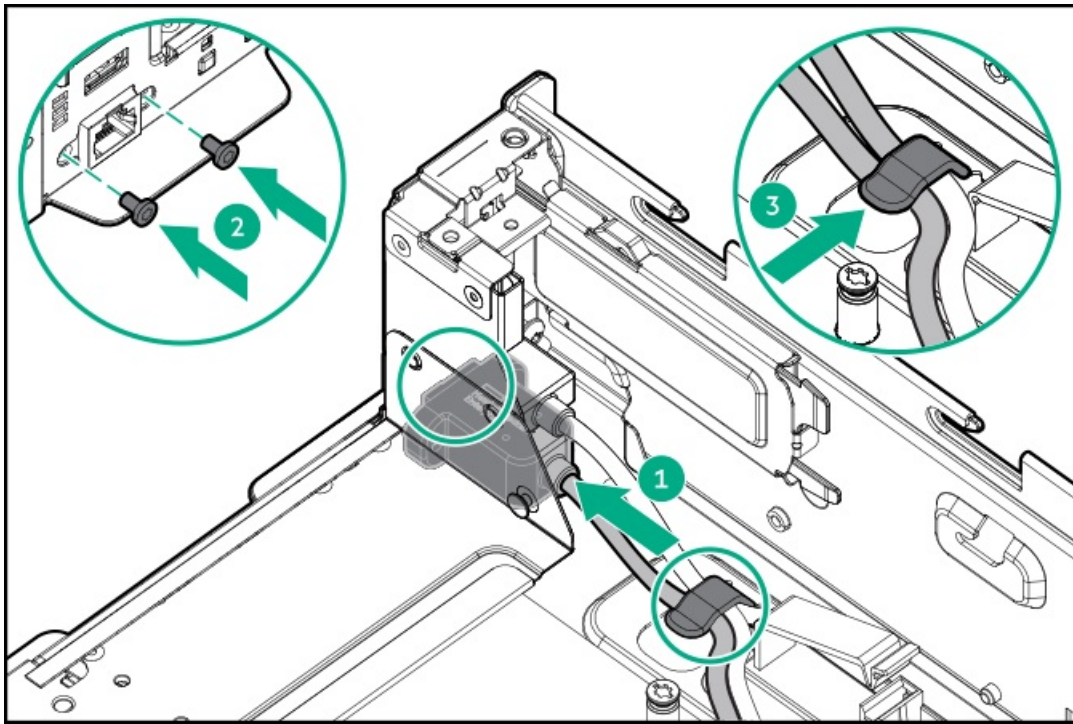

14. Connect the serial port cable to the system board.
15. If removed, install the boot device.
16. Install the drive base cage.
17. Install the three-slot riser cage.
18. Install the air baffle.
19. Install the access panel.
20. Install the server into the rack.
21. Connect all peripheral cables to the server.
22. Connect each power cord to the server.
23. Connect each power cord to the power source.
24. Power up the server.
25. If removed, install the front bezel.
26. Configure the serial port settings:
 - a. From the boot screen, press **F9** to access the UEFI System Utilities.
 - b. From the System Utilities screen, select System Configuration > BIOS/Platform Configuration (RBSU) > System Options > Serial Port Options > Embedded Serial Port.
 - c. Select a setting.
 - d. Press **F12** key to save your selection.
 - e. Click Yes-Save Changes.
 - f. Click Reboot.

Results

The installation procedure is complete.

Cabling

This chapter includes cabling guidelines and diagrams for internal component cabling.

Subtopics

[Cabling guidelines](#)

[Cabling diagrams](#)

[Internal cabling management](#)

[Stacking riser cabling](#)

[Storage cabling](#)

[HPE NS204i-u Boot Device cabling](#)

[iLO service port cabling](#)

[RJ45-serial port cabling](#)

[Ambient temperature sensor cabling](#)

[System power cabling](#)

[Chassis intrusion detection switch cabling](#)

Cabling guidelines

Observe the following:



NOTE

The colors in the cabling diagrams are for illustration purposes only.

- For cable option kits, see the product QuickSpecs.
- For cable spare part numbers, see the Illustrated parts catalog in the maintenance and service guide.
- Some diagrams show alphabetical callouts such as A, B, C, etc. These callouts correspond to labels near the connectors on the cable.
- Some cables have more than one connector, such as a Y-cable, but not all connectors are used.
- Observe all guidelines when working with server cables.

Before connecting cables

- Note the port labels on the PCA components. Not all these components are used by all servers:
 - System board ports
 - Drive and power supply backplane ports
 - Expansion board ports (controllers, retimers, adapters, expanders, risers, and similar boards)
- Note the label near each cable connector. This label indicates the destination port for the cable connector.
- Some data cables are prebent. Do not unbend or manipulate the cables.
- To prevent mechanical damage or depositing oil that is present on your hands, and other contamination, do not touch the ends of the connectors.

When connecting cables

- Before connecting a cable to a port, lay the cable in place to verify the length of the cable.
- Use the internal cable management features to properly route and secure the cables.

- When routing cables, be sure that the cables are not in a position where they can be pinched or crimped.
- Avoid tight bend radii to prevent damaging the internal wires of a power cord or a server cable. Never bend power cords and server cables tight enough to cause a crease in the sheathing.
- Make sure that the excess length of cables is properly secured to avoid excess bends, interference issues, and airflow restriction.
- To prevent component damage and potential signal interference, make sure that all cables are in their appropriate routing position before installing a new component and before closing up the server after hardware installation/maintenance.

When disconnecting cables

- Grip the body of the cable connector. Do not pull on the cable itself because this action can damage the internal wires of the cable or the pins on the port.
- If a cable does not disconnect easily, check for any release latch that must be pressed to disconnect the cable.

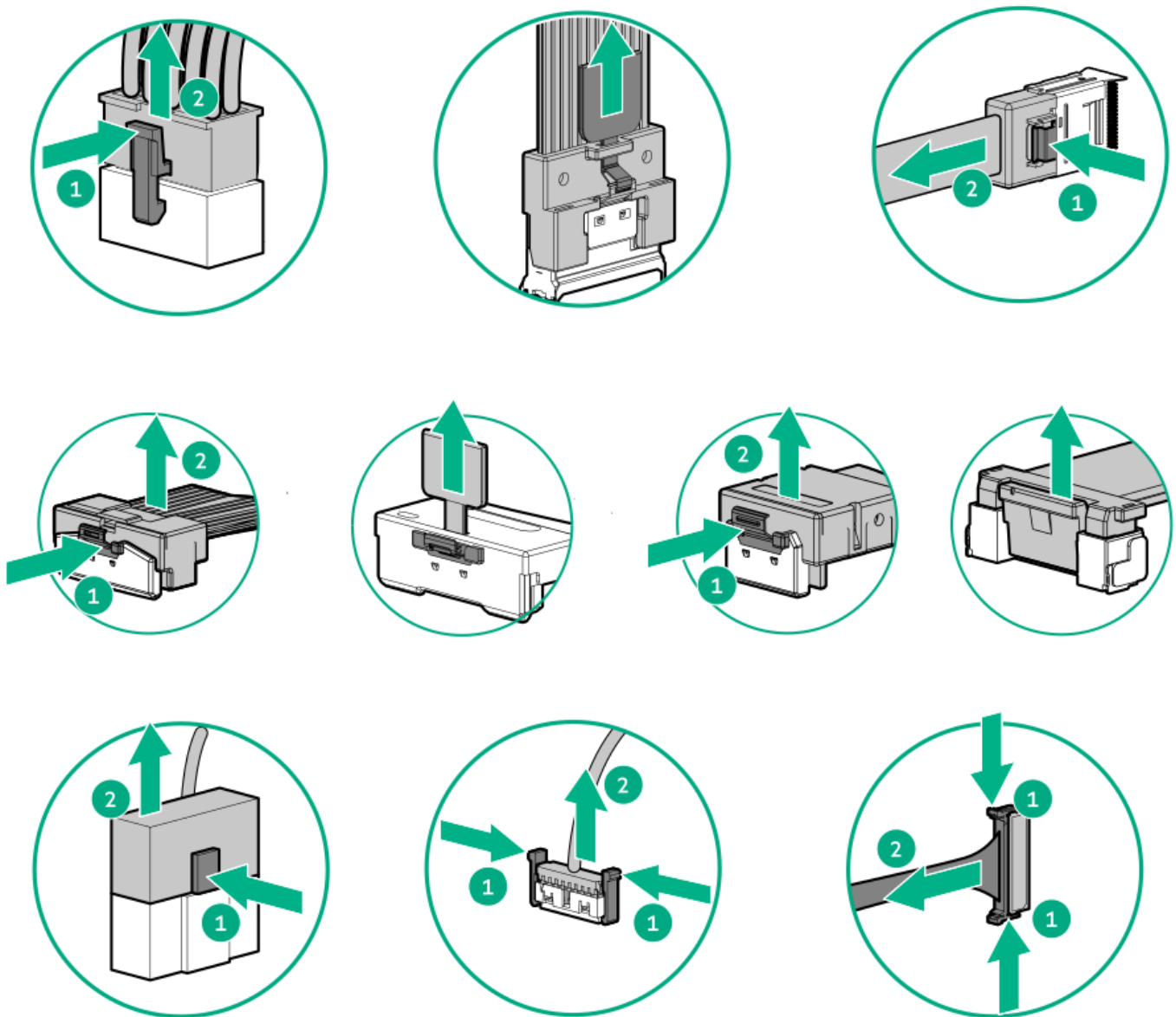

- Remove cables that are no longer being used. Retaining them inside the server can restrict airflow. If you intend to use the removed cables later, label and store them for future use.



Cabling diagrams

Observe the following:

- Before cabling components, see the [Cabling guidelines](#).
- Use the cable part number or search feature to find your diagram.



Component cabling	Cable part number
Stacking riser cabling	—
PCIe Slot 1 stacking cabled riser	P51472-001
PCIe Slot 2 stacking cabled riser	P50365-001
Storage Cabling	—
2 SFF drive: Onboard SATA cable	P57307-001
2 SFF drive: Onboard NVMe cable	P57311-001
2 SFF drive controller cable: Type-p controller in the three-slot riser cage	P63696-001
4 E3.S NVMe drive direct attach cable	P59100-001
4 E3.S drive controller cable: Type-o controller in slot 21	P72526-001
4 E3.S drive controller cable: Type-p controller in the three-slot riser cage	P51556-001
2 E3.S Box 1 direct attach cable	P70286-001
2 E3.S Box 1 drive controller cable: Type-p controller in the three-slot riser cage	P72524-001
4 + 2 E3.S drive controller cable: Type-p controller in the three-slot riser cage	P72525-001
4 + 2 E3.S drive power cable	P70282-001
2 SFF drive power cable	P70281-001
Energy pack cabling	—
Energy pack	P01366-B21
HPE NS204i-u Boot Device cabling	—
HPE NS204i-u Boot Device power cable	P54088-001
HPE NS204i-u Boot Device signal cable	P54087-001
Miscellaneous component cabling	—
Power supply sideband cable	P54888-001
System board power cable	P70280-001
iLO service port cable	P70284-001
RJ45-serial port cable	P70285-001
Ambient temperature sensor cable	P37227-001
Chassis intrusion detection switch cable	P47751-001

Internal cabling management

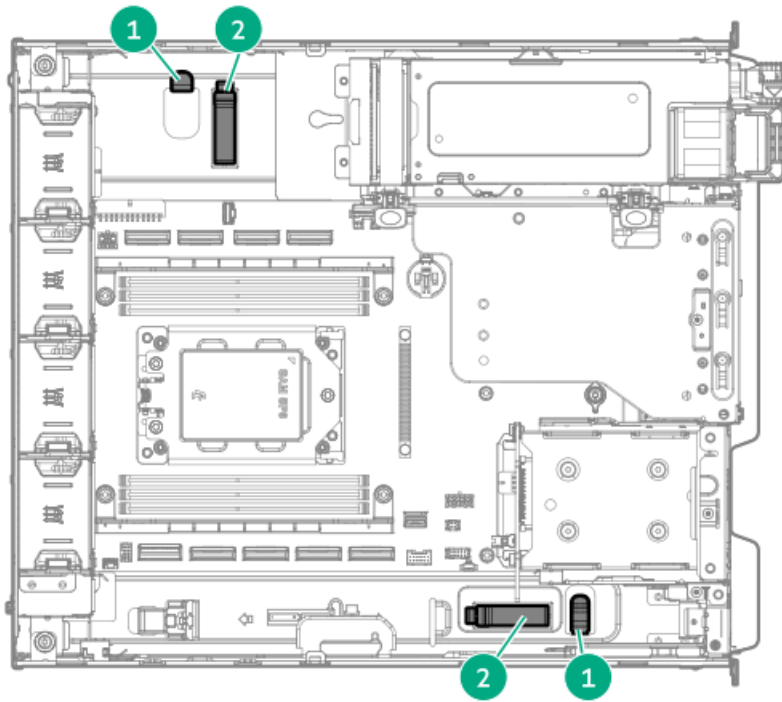

Item Description

- 1 Metal tab
- 2 Cable clamp

Stacking riser cabling

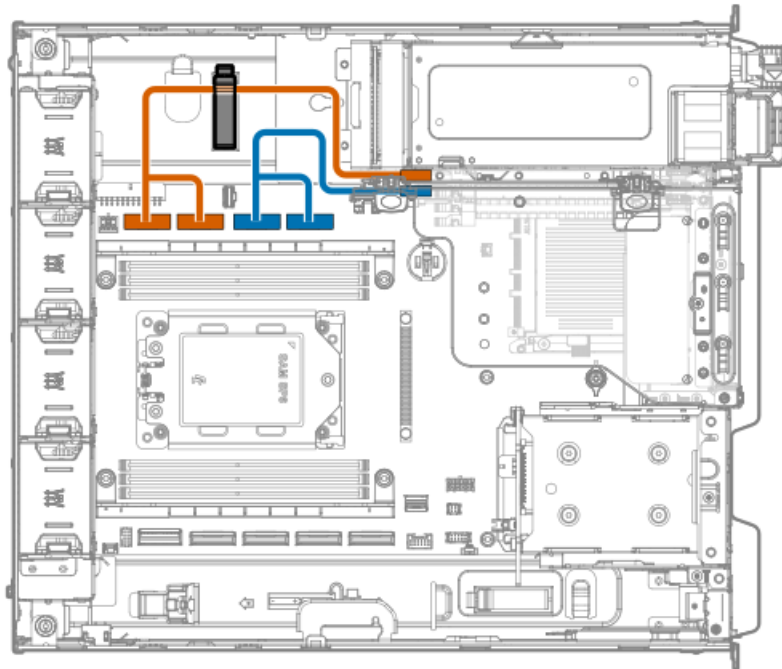

Riser part number	Color	From	To
P51472-001	Orange	PCIe Slot 1 stacking cabled riser	NVMe port 3A (SEC) and 4A (PRIM)
P50365-001	Blue	PCIe Slot 2 stacking cabled riser	NVMe port 5A (SEC) and 6A (PRIM)

Storage cabling

Subtopics

[Storage controller cabling](#)

[Drive power cabling](#)

[Energy pack cabling](#)

[Storage controller backup power cabling](#)

Storage controller cabling

Subtopics

[2 SFF SATA/NVMe drive controller cabling](#)

[4 E3.S NVMe drive controller cabling](#)

[4 + 2 E3.S NVMe drive controller cabling](#)

2 SFF SATA/NVMe drive controller cabling

2 SFF drive: Direct attached SATA/NVMe cabling

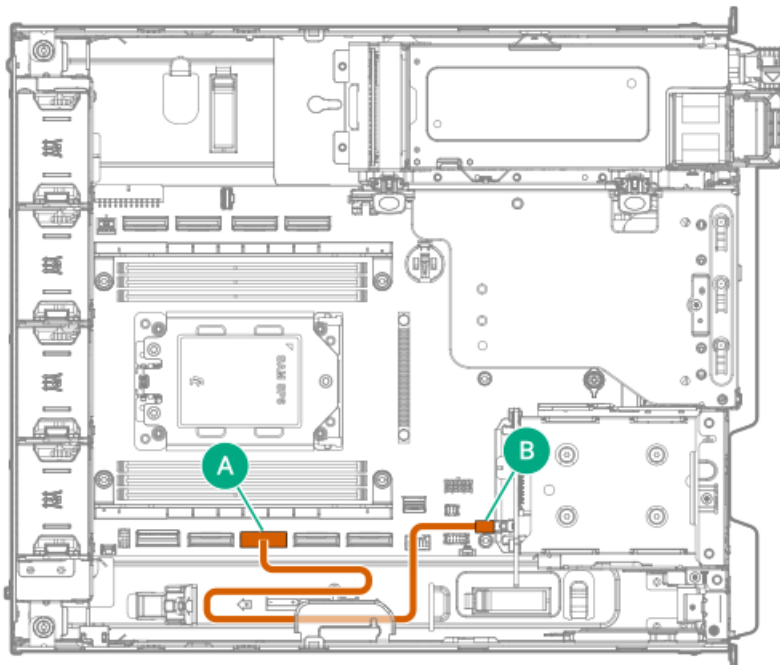

Cable part number	Cable color	From	To
SATA: P57307-001	Orange	Box 1 port 1	NVMe/SATA port 1A
NVMe: P57311-001	Orange	Box 1 port 1	NVMe/SATA port 1A

2 SFF drive controller cabling: Type-p storage controller in the three-slot riser cage

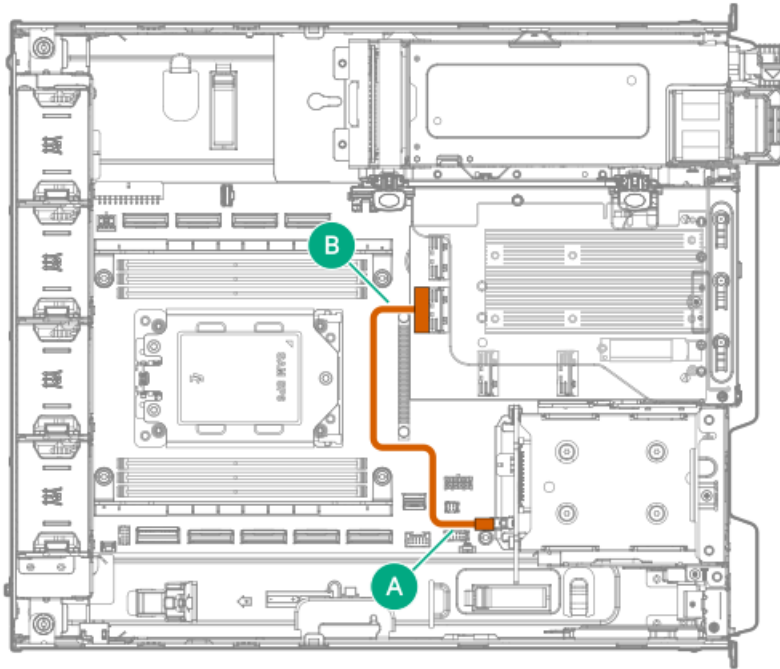

Cable part number	Cable color	From	To
P63696-001	Orange	Box 1 port 1	Type-p storage controller port 1

4 E3.S NVMe drive controller cabling

4 E3.S drive: Direct attached NVMe cabling



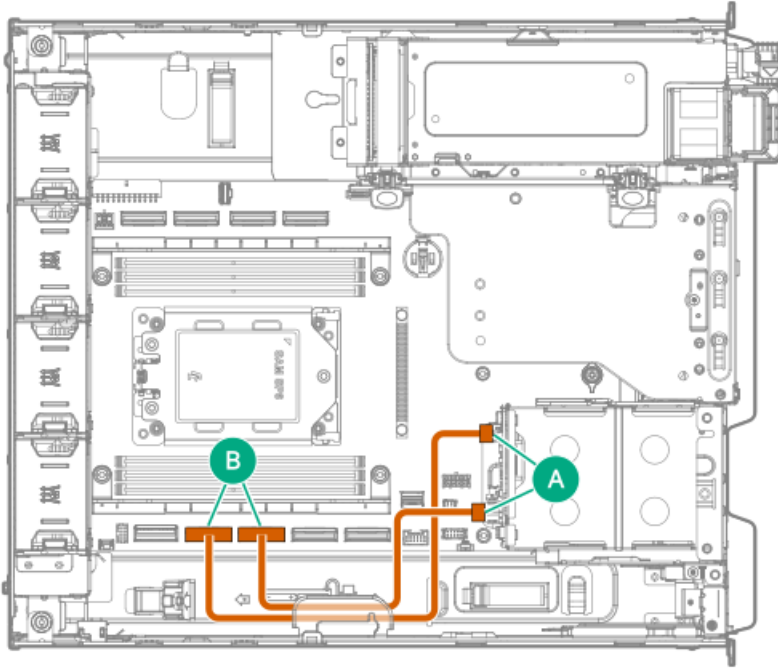

Cable part number	Cable color	From	To
P59100-001 ¹	Orange	Box 2 port 1	NVMe port 1A
		Box 2 port 2	NVMe port 2A

¹ Option kit: P71985-B21

4 E3.S drive controller cabling: Type-o storage controller in slot 21

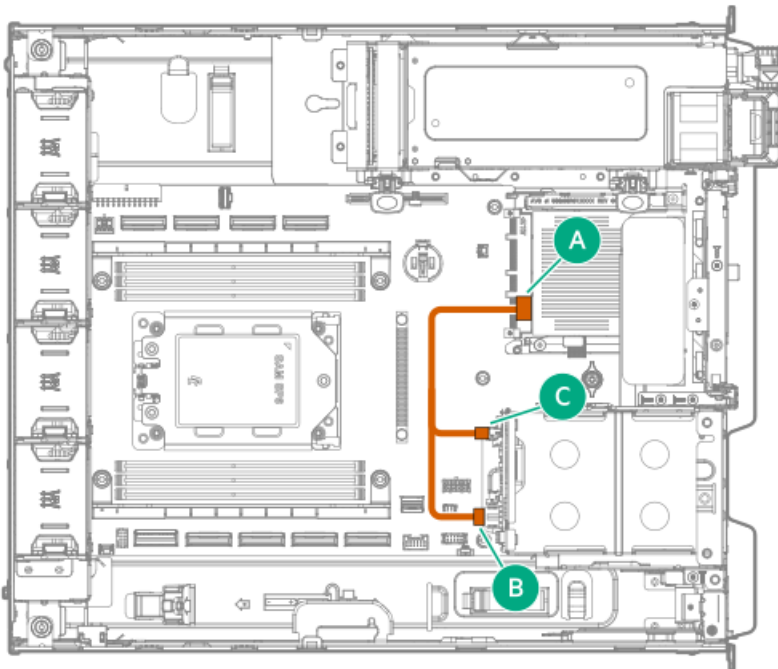

Cable part number	Cable color	From	To
P72526-001 ¹	Orange	Box 2 ports 1-2	Type-o storage controller port 1



¹ Option kit: P72002-B21

4 E3.S drive controller cabling: Type-p storage controller in the three-slot riser cage

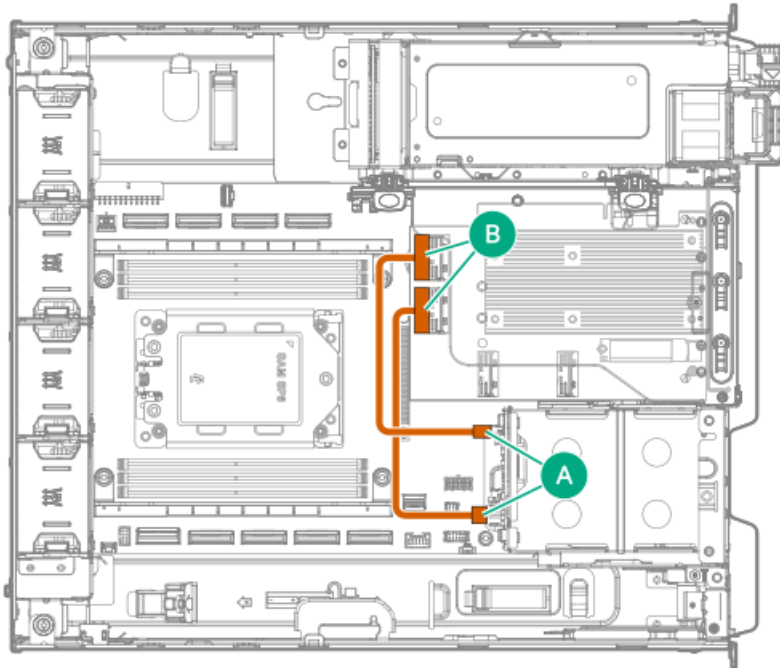

Cable part number	Cable color	From	To
P51556-001 ¹	Orange	Box 2 port 1	Type-p storage controller port 1
		Box 2 port 2	Type-p storage controller port 2

¹ Option kit: P73003-B21

4 + 2 E3.S NVMe drive controller cabling

The server supports 2 E3.S drives in Box 1 using the 6 E3.S enablement cable option (only for the 4 E3.S drive configuration).

2 E3.S drive: Direct attached NVMe cabling



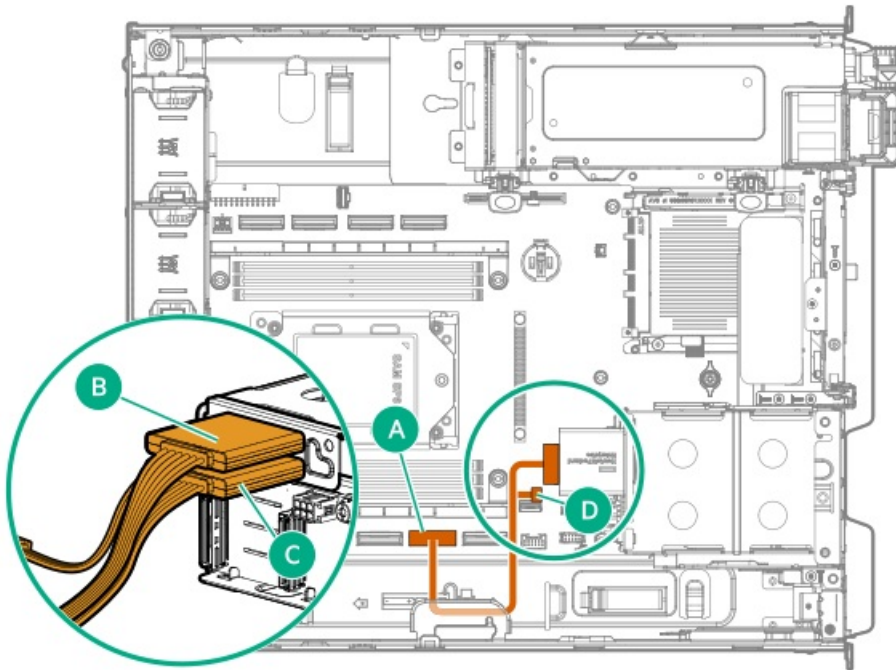

Cable part number	Cable color	From	To
P70286-001 ¹	Orange	Box 1	MCIO port 8A / 6 E3.S drive power Y cable

¹ Option kit: P71981-B21

4 + 2 E3.S drive controller cabling: Type-p storage controller in the three-slot riser cage

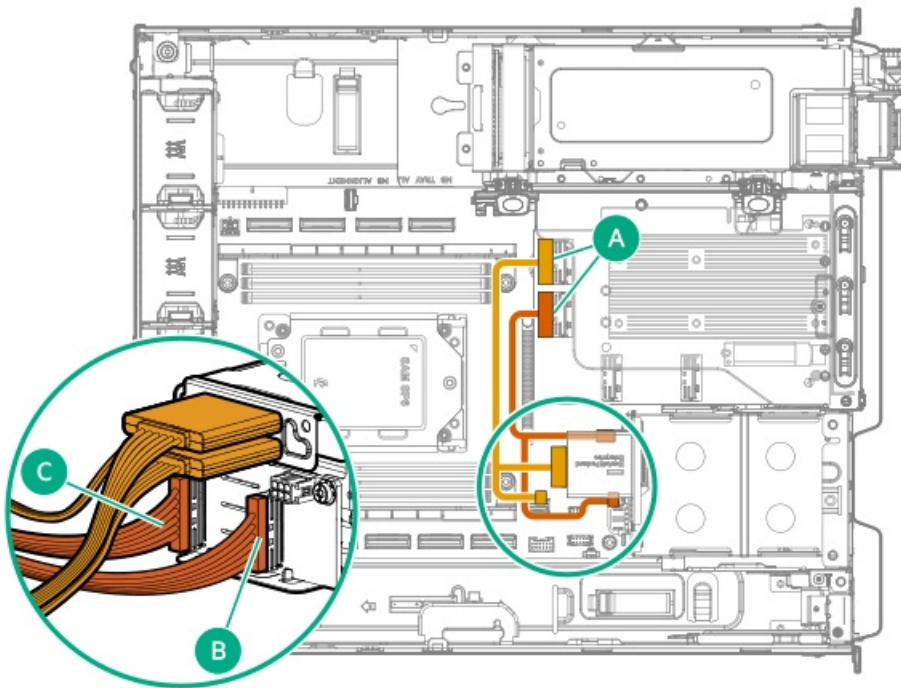

Cable part number	Cable color	From	To
P72525-001 ¹	Orange	Box 2 ports 1-2	Type-p storage controller port 1
P72524-001 ¹	Gold	Box 1	Type-p storage controller port 2 / 6 E3.S drive power Y cable

¹ Option kit: P72004-B21

Drive power cabling

2 SFF drive power cable

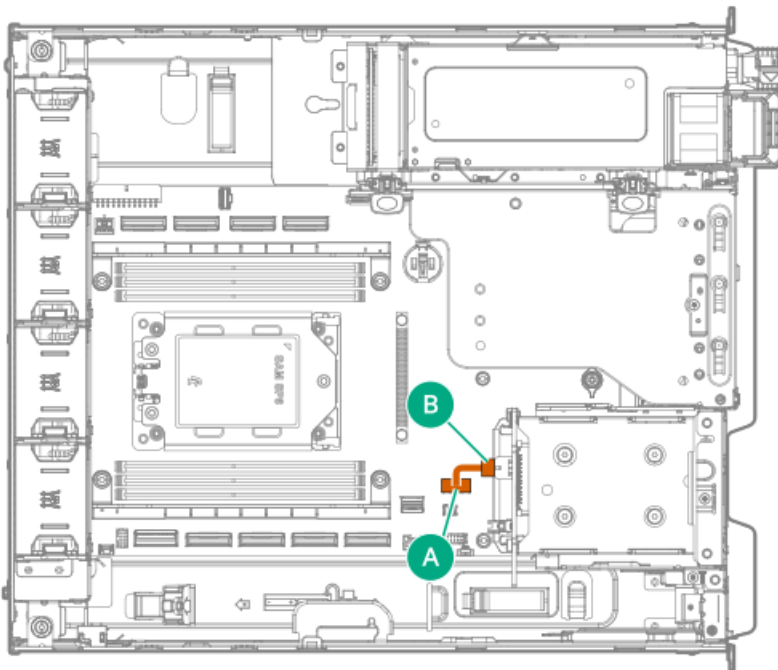

Cable part number	Cable color	From	To
P70281-001 ¹	Orange	Box 1	Backplane power connector (J9019)

¹ Option kit: P71977-B21

6 E3.S drive power Y cable

This cable is used in 4 or 4 + 2 E3.S drive configuration.

4 E3.S drive configuration:



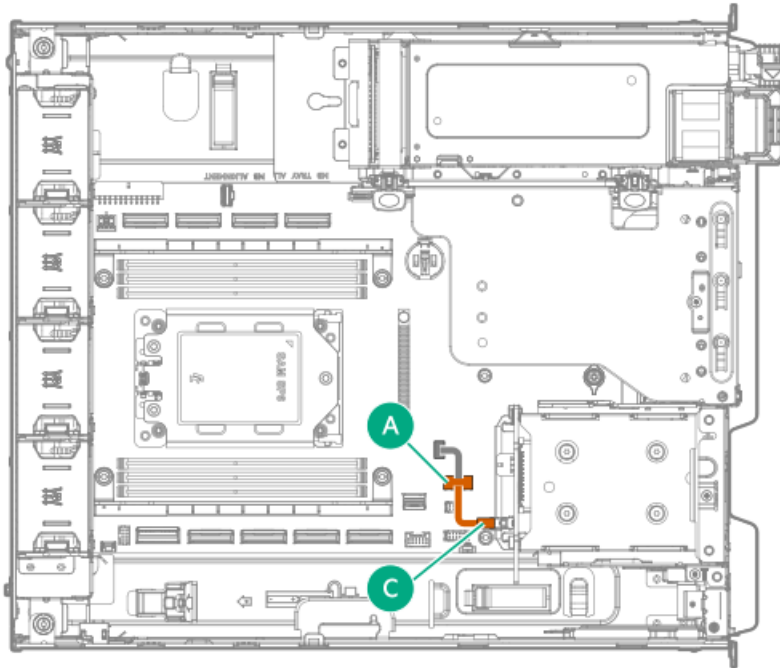

Cable part number	Cable color	From	To
P70282-001	Orange	Box 2	Backplane power connector (J9019) / Box 1

4 + 2 E3.S drive configuration:

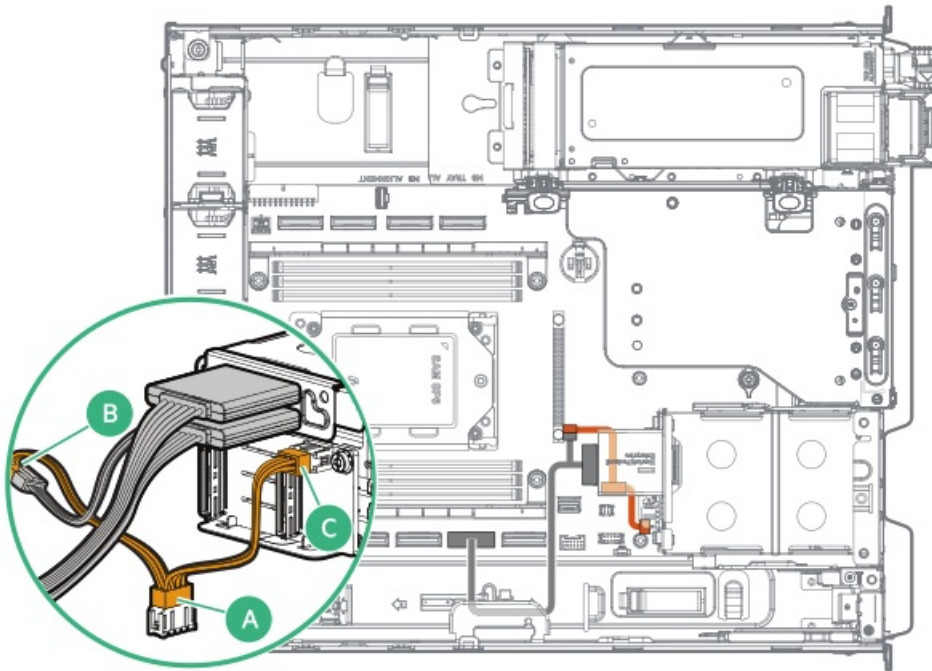

Cable part number	Cable color	From	To
P70282-001 ¹	Orange	Box 1—2	Backplane power connector (J9019)

¹ Option kit: P71985-B21

Energy pack cabling

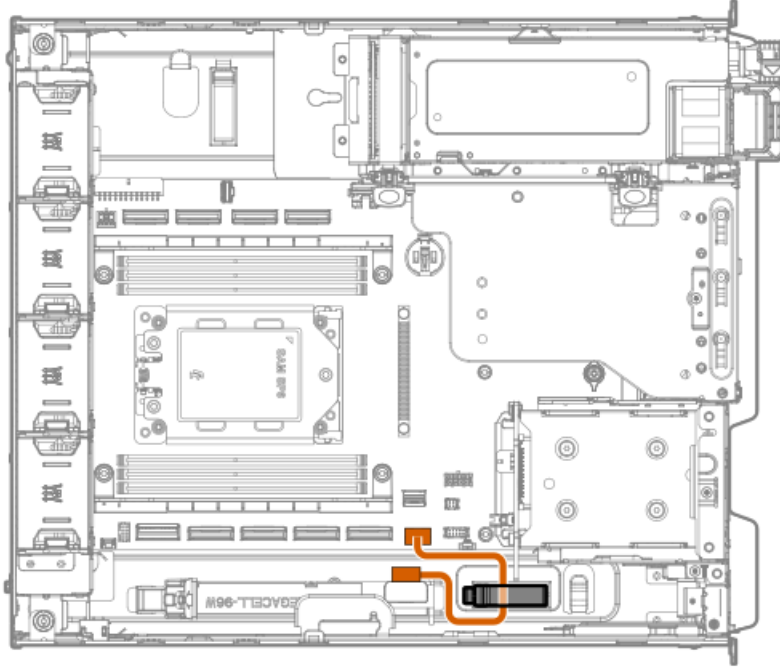

Cable color	From	To
Orange	Energy pack	Energy pack connector

Option kit: P01366-B21

Storage controller backup power cabling

The exact route of the storage controller backup power cabling will depend on:

- The riser slot where the controller is installed
- The location of the storage controller backup power connector on the controller

Use the following diagrams for reference only.

Type-p controller

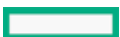

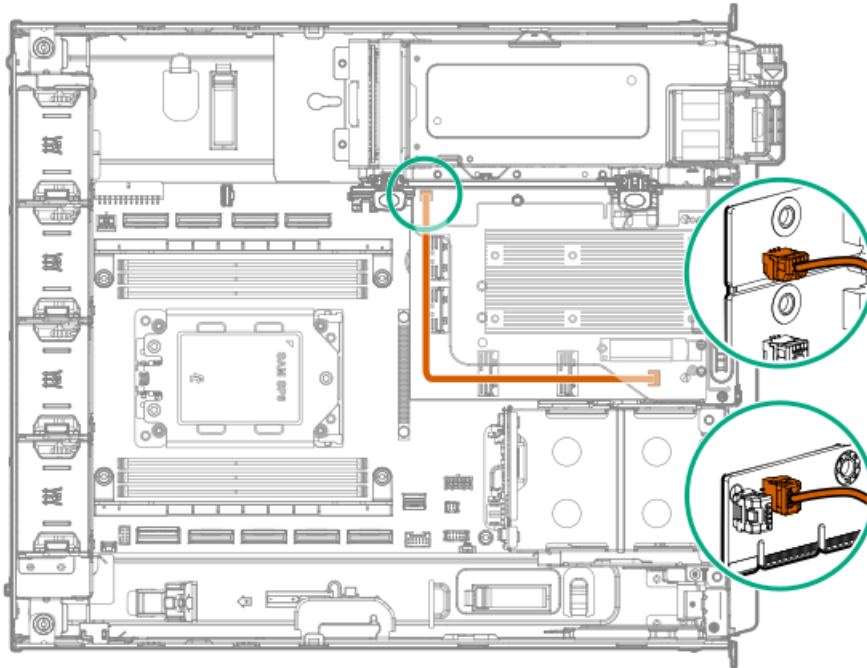

Color	From	To
Orange	Type-p controller	Storage controller backup power connector on the riser board

Type-o controller

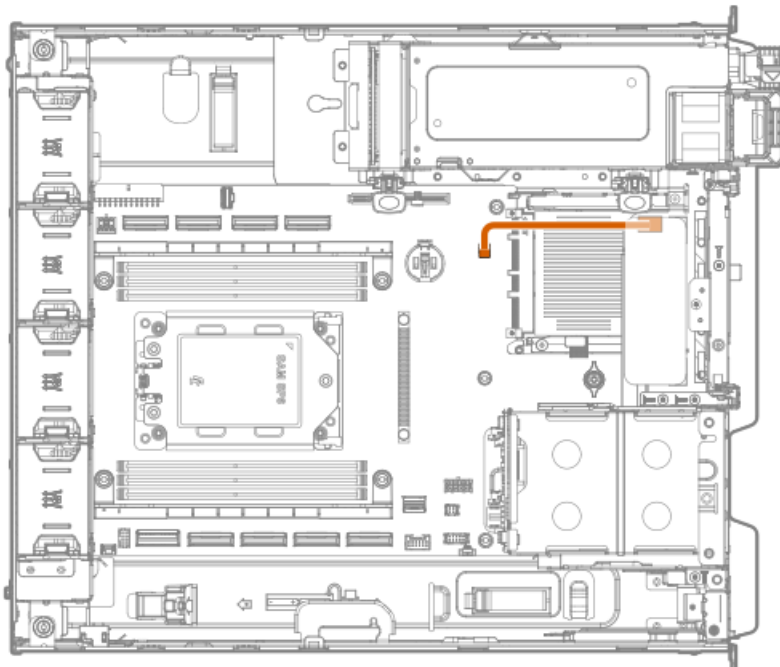

Color	From	To
Orange	Type-o controller in Slot 22	Storage backup power connector on the system board

HPE NS204i-u Boot Device Cabling

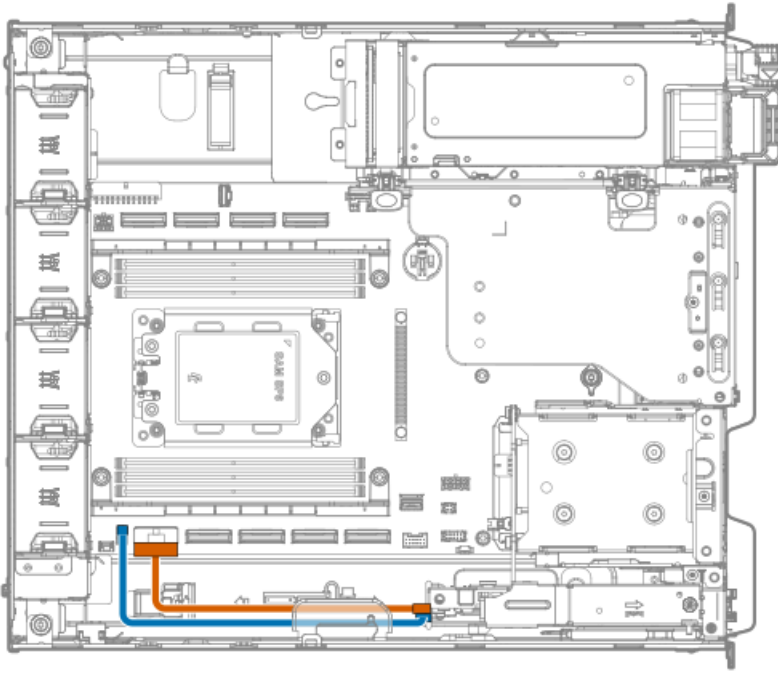

Cable part number	Color	From	To
P54088-001 ¹	Blue	HPE NS204i-u Boot Device	Boot device power connector
P54087-001 ¹	Orange		Boot device signal connector

¹ Option kit: P71992-B21

iLO service port cabling

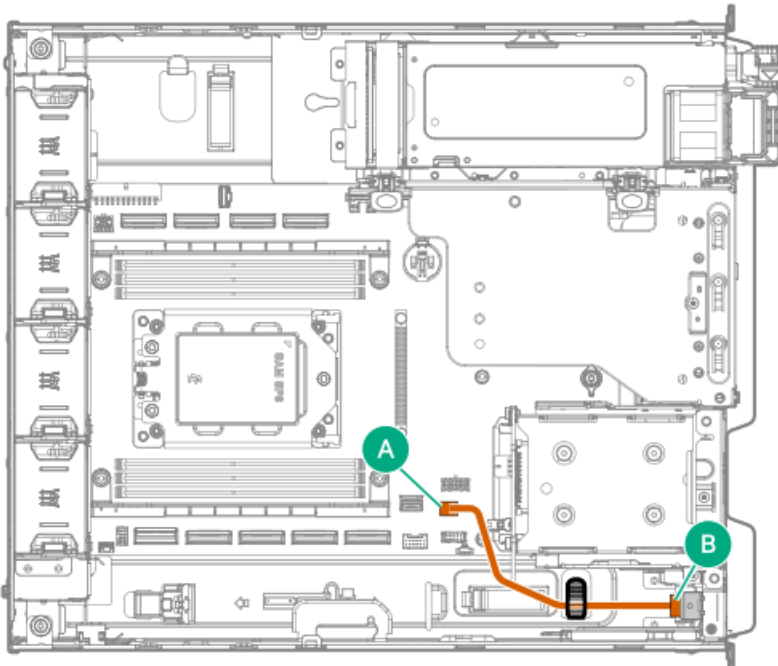

Cable part number	Color	From	To
P70284-001	Orange	iLO service port	iLO service port connector

RJ45-serial port cabling

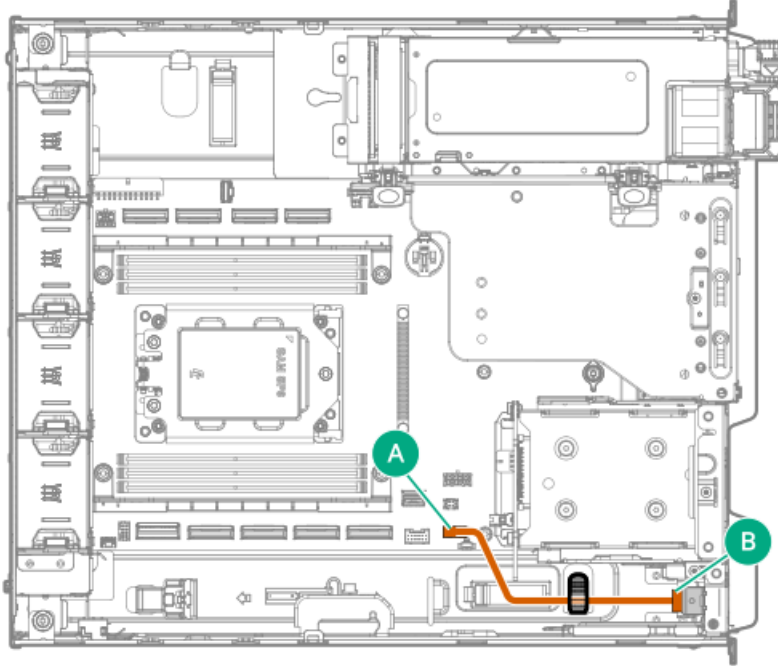

Cable part number	Color	From	To
P70285-001 ¹	Orange	RJ45-serial port	Serial port connector

¹ Option kit: P71998-B21

Ambient temperature sensor cabling



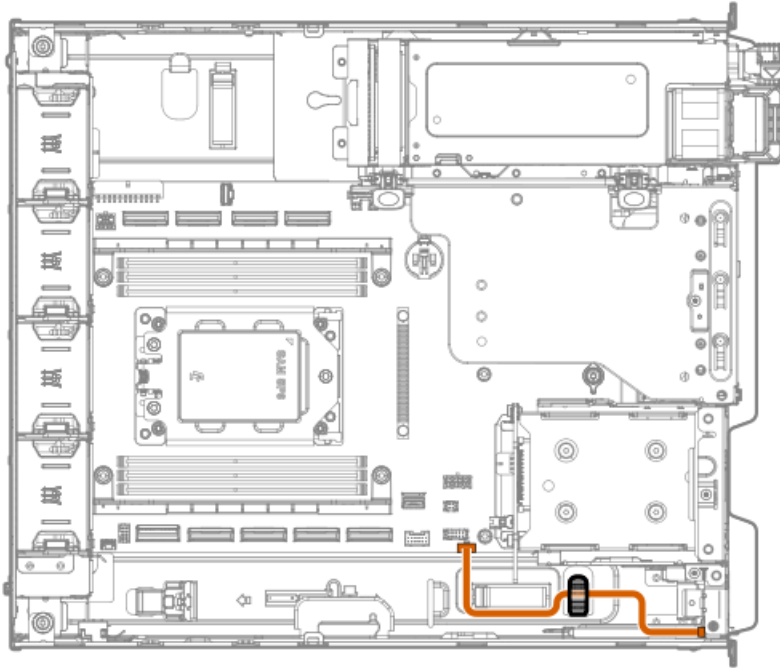

Cable part number	Color	From	To
P37227-001	Orange	Ambient temperature sensor	System board: Remote temperature sensor connector

System power cabling

The power cables that connect the PDB to the system board are pre-installed in the server.

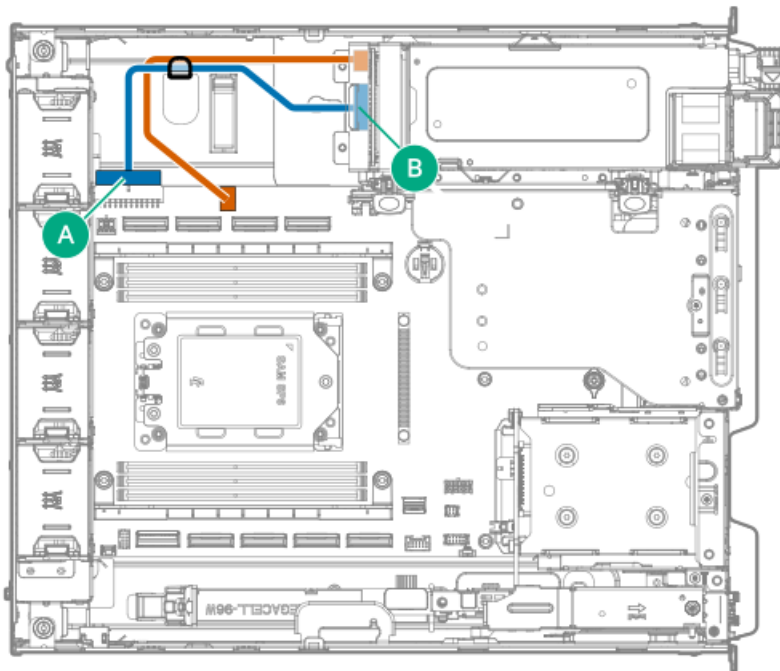

Cable part number	Cable color	From	To
P54888-001	Orange	PDB: Power supply sideband connector	System board: Power supply sideband connector
P70280-001	Blue	PDB: System board power connector	System board: System board power connector

Chassis intrusion detection switch cabling

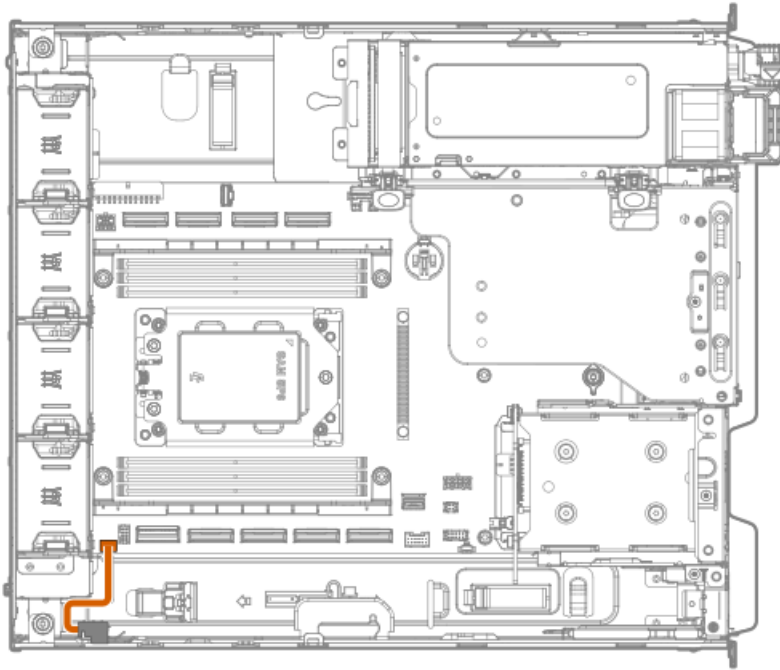

Cable part number	Color	From	To
P47751-001 ¹	Orange	Chassis intrusion detection switch	Chassis intrusion detection switch connector

¹ Option kit: P48922-B21

Configuration resources

Use the following resources to find documentation for configuring and managing your server.

- Some utilities might not apply to your server. For information about server compatibility with the products listed in this chapter, see the product QuickSpecs (<https://www.hpe.com/info/quickspecs>).
- Products ordered from HPE Factory Express might have already been configured with some or all the configurations in this chapter. To determine if any additional setup is required, see your HPE Factory Express order.
- For one-stop access to version-specific software and firmware documentation, including the latest product release notes, see this quick links page:
<https://www.hpe.com/support/hpeproductdocs-quicklinks>

Subtopics

- [Updating firmware or system ROM](#)
- [Configuring the server](#)
- [Configuring storage controllers](#)
- [Deploying an OS](#)
- [Configuring security](#)
- [Server management](#)
- [Managing Linux-based high performance compute clusters](#)

Updating firmware or system ROM

To	Use
Download service packs	<ul style="list-style-type: none"> • Service Pack for ProLiant (SPP) <ul style="list-style-type: none"> https://www.hpe.com/servers/spp/download • Get an overview of SPP and its ecosystem <ul style="list-style-type: none"> https://www.hpe.com/support/SPP-overview-videos-en
Deploy service packs to a single server	Smart Update Manager (SUM) https://www.hpe.com/support/hpesmartupdatemanager-quicklinks
Deploy service packs to multiple servers	HPE OneView https://www.hpe.com/support/hpeoneview-quicklinks
Updating iLO or system firmware in a single server or multiple servers	HPE iLO https://www.hpe.com/support/hpeilodocs-quicklinks
<ul style="list-style-type: none"> • Enable policy-based management of server or server group firmware for distributed server infrastructure • Monitor server compliance with a configured firmware baseline • Receive automatic iLO firmware updates • Receive baseline update alerts 	HPE Compute Ops Management https://www.hpe.com/support/hpe-gl-com-quicklinks

Configuring the server



To configure

Use

Single server (GUI)

- Intelligent Provisioning
<https://www.hpe.com/support/hpeintelligentprovisioning-quicklinks>
- iLO remote console or web interface
<https://www.hpe.com/support/hpeilodocs-quicklinks>
- UEFI System Utilities
<https://www.hpe.com/support/hpeuefisystemutilities-quicklinks>
- HPE Compute Ops Management
<https://www.hpe.com/support/hpe-gl-com-quicklinks>

Single server (scripting)

- RESTful Interface Tool
<https://www.hpe.com/support/restfulinterface/docs>
- Python iLO Redfish Library (python-ilorest-library)
<https://github.com/HewlettPackard/python-ilorest-library>
- Scripting Tools for Windows Powershell
<https://www.hpe.com/info/powershell/docs>
- iLO RESTful API
<https://servermanagementportal.ext.hpe.com/>
- HPE Compute Ops Management API
<https://developer.greenlake.hpe.com/>

Multiple servers (either UI or scripting)

- HPE OneView ¹
<https://www.hpe.com/support/hpeoneview-quicklinks>
- HPE Compute Ops Management
<https://www.hpe.com/support/hpe-gl-com-quicklinks>
 - **Server settings:** Define server-specific parameters such as firmware baselines, and then apply them to server groups.
 - **Server groups:** Organize servers into custom-defined sets with associated server settings, and then apply group-specific policies to create a consistent configuration across the servers in the group.

¹ For servers running HPE OneView, do not use another tool, such as iLO, to delete or change certain settings. For more information about using HPE OneView and iLO to manage the same server, see the iLO user guide at <https://www.hpe.com/support/hpeilodocs-quicklinks>.

Configuring storage controllers

Controller type	Documentation
HPE MR Gen11 controllers	<p>HPE MR Gen11 Controller User Guide</p> <p>https://hpe.com/support/MR-Gen11-UG</p> <p>Configuration guides:</p> <ul style="list-style-type: none"> HPE MR Storage Administrator User Guide https://www.hpe.com/support/MRSA HPE StorCLI User Guide https://www.hpe.com/support/StorCLI
Storage controller documents library	https://www.hpe.com/support/hpestoragecontrollerdocs-quicklinks

Deploying an OS

For a list of supported operating systems, see the HPE Servers Support & Certification Matrices:

<https://www.hpe.com/support/Servers-Certification-Matrices>

To	See
Deploy an OS using HPE Compute Ops Management	<p>HPE Compute Ops Management User Guide</p> <p>https://www.hpe.com/support/hpe-gl-com-quicklinks</p>
Deploy an OS using Intelligent Provisioning	<p>Intelligent Provisioning user guide</p> <p>https://www.hpe.com/support/hpeintelligentprovisioning-quicklinks</p>
Deploy an OS using iLO virtual media	<p>iLO user guide</p> <p>https://www.hpe.com/support/hpeilodocs-quicklinks</p>
Configure the server to boot from a PXE server	<p>UEFI System Utilities User Guide for HPE ProLiant Gen11 Servers and HPE Synergy</p> <p>https://www.hpe.com/support/UEFIGen11-UG-en</p>
Configure the server to boot from a SAN	<p>HPE Boot from SAN Configuration Guide</p> <p>https://www.hpe.com/info/boot-from-san-config-guide</p>

Configuring security

To	See
Implement server security best practices.	<ul style="list-style-type: none"> • HPE Compute Security Reference Guide https://www.hpe.com/info/server-security-reference-en • HPE iLO 6 Security Technology Brief https://www.hpe.com/support/ilo6-security-en
Configure and use the Server Configuration Lock feature on HPE Trusted Supply Chain servers and other servers that have the Server Configuration Lock feature enabled.	Server Configuration Lock User Guide for HPE ProLiant servers and HPE Synergy https://www.hpe.com/info/server-config-lock-UG-en

Server management

To monitor	See
Single server	HPE iLO https://www.hpe.com/support/hpeilodocs-quicklinks
Multiple servers	HPE OneView https://www.hpe.com/support/hpeoneview-quicklinks
Single or multiple servers	HPE Compute Ops Management https://www.hpe.com/support/hpe-gl-com-quicklinks

Managing Linux-based high performance compute clusters

To	Use
Provision, manage, and monitor clusters.	HPE Performance Cluster Manager https://www.hpe.com/support/hpcm_manuals
Optimize your applications.	HPE Performance Analysis Tools https://www.hpe.com/info/perftools
Optimize software library for low latency and high bandwidth, both on-node and off-node, for point-to-point and collective communications.	HPE Cray Programming Environment User Guide https://www.hpe.com/info/cray-pe-user-guides

Troubleshooting

Subtopics

- [NMI functionality](#)
- [Troubleshooting resources](#)

NMI functionality

An NMI crash dump enables administrators to create crash dump files when a system is not responding to traditional debugging methods.

An analysis of the crash dump log is an essential part of diagnosing reliability problems, such as hanging operating systems, device drivers, and applications. Many crashes freeze a system, and the only available action for administrators is to cycle the system power. Resetting the system erases any information that could support problem analysis, but the NMI feature preserves that information by performing a memory dump before a hard reset.

To force the OS to initiate the NMI handler and generate a crash dump log, the administrator can use the iLO Generate NMI feature.

Troubleshooting resources

Troubleshooting resources are available for HPE Gen11 server products in the following documents:

- Troubleshooting Guide for HPE ProLiant Gen11 servers provides procedures for resolving common problems and comprehensive courses of action for fault isolation and identification, issue resolution, and software maintenance.

<https://www.hpe.com/info/gen11-troubleshooting>

- Integrated Management Log Messages for HPE ProLiant Gen10, Gen10 Plus, and Gen11 servers and HPE Synergy provides IML messages and associated troubleshooting information to resolve critical and cautionary IML events.

<https://www.hpe.com/info/Troubleshooting-IML-en>

System battery replacement

If the server no longer automatically displays the correct date and time, then replace the battery that provides power to the real-time clock. Under normal use, battery life is 5–10 years.

Subtopics

[System battery information](#)

[Removing and replacing the system battery](#)

System battery information

The server contains an internal lithium manganese dioxide, a vanadium pentoxide, or an alkaline battery that provides power to the real-time clock.





WARNING

If this battery is not properly handled, a risk of fire or burning exists. To reduce the risk of personal injury:

- Do not attempt to recharge the battery.
- Do not expose the battery to temperatures higher than 60°C (140°F).
- Do not expose the battery to low air pressure as it might lead to explosion or leakage of flammable liquid or gas.
- Do not disassemble, crush, puncture, short external contacts, or dispose of the battery in fire or water.

Removing and replacing the system battery

Prerequisites

Before you perform this procedure, make sure that you have a small flat-bladed, nonconductive tool available.

About this task



CAUTION

A discharge of static electricity from a finger or other conductor might damage system boards or other static-sensitive devices. To prevent damage, observe [antistatic precautions](#).



IMPORTANT

After replacing the system battery and applying power, wait for 10 minutes before powering on the server. This lead time is required for the server to reset and reinitialize the iLO configuration settings stored in SRAM.

Procedure

1. If installed, [remove the front bezel](#).
2. [Power down the server](#).
3. Remove all power:
 - a. Disconnect each power cord from the power source.
 - b. Disconnect each power cord from the server.
4. Disconnect all peripheral cables from the server.
5. [Remove the server from a four-post rack](#).
6. Place the server on a flat, level work surface.
7. [Remove the access panel](#).
8. [Remove the air baffle](#).
9. [Remove the three-slot riser cage](#).
10. [Locate the battery on the system board](#).
11. Remove the system battery:

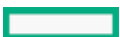

- a. Use a small flat-bladed, nonconductive tool to press the battery latch.
- b. Remove the system battery from the socket.

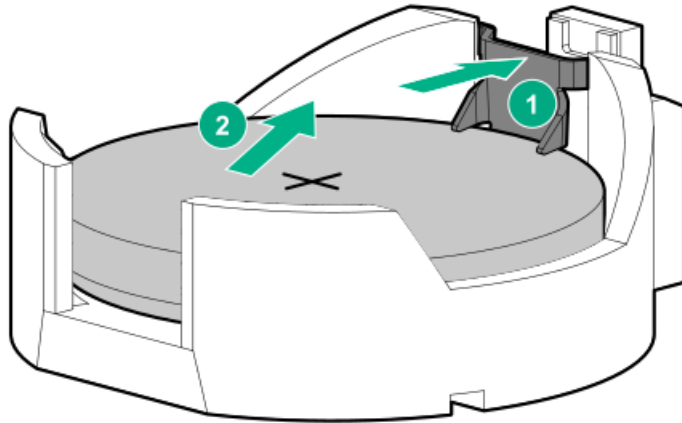

12. Install the system battery:

- a. With the side of the battery showing the "+" sign facing up, insert the battery into the socket.
- b. Press the system battery down until it clicks into place.

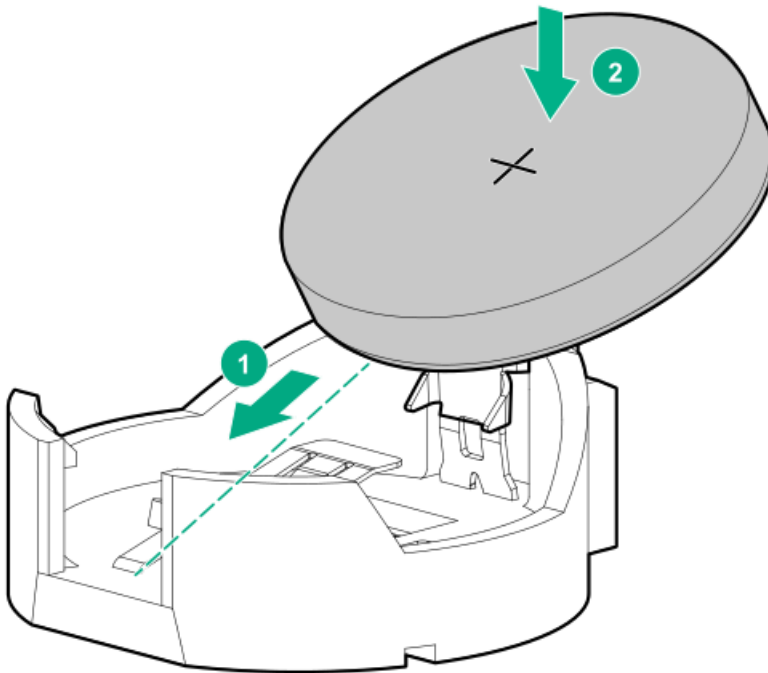

13. Install the three-slot riser cage.
14. Install the air baffle.
15. Install the access panel.
16. Install the server into the rack.
17. Connect all peripheral cables to the server.
18. Connect each power cord to the server.
19. Connect each power cord to the power source.



20. Wait for 10 minutes for the server to reset and reinitialize the iLO configuration settings stored in SRAM.



IMPORTANT

If iLO security is disabled, the configuration will not be restored. To restore the configuration manually, see <https://www.hpe.com/support/hpeilodocs-quicklinks>.

21. Power up the server.
22. If removed, install the front bezel.
23. Properly dispose of the old battery.

For more information about proper battery disposal, contact an authorized reseller or an authorized service provider.

Results

The replacement procedure is complete.

Safety, warranty, and regulatory information

Subtopics

[Regulatory information](#)

[Warranty information](#)

Regulatory information

To view the regulatory information for your product, view the [Safety and Compliance Information for Server, Storage, Power, Networking, and Rack Products](#), available at the Hewlett Packard Enterprise Support Center:

<https://www.hpe.com/support/Safety-Compliance-EnterpriseProducts>

Additional regulatory information

Hewlett Packard Enterprise is committed to providing our customers with information about the chemical substances in our products as needed to comply with legal requirements such as REACH (Regulation EC No 1907/2006 of the European Parliament and the Council). A chemical information report for this product can be found at:

<https://www.hpe.com/info/reach>

For Hewlett Packard Enterprise product environmental and safety information and compliance data, including RoHS and REACH, see:

<https://www.hpe.com/info/ecodata>

For Hewlett Packard Enterprise environmental information, including company programs, product recycling, and energy efficiency, see:

<https://www.hpe.com/info/environment>

Subtopics

[Notices for Eurasian Economic Union](#)

[Turkey RoHS material content declaration](#)

[Ukraine RoHS material content declaration](#)

Notices for Eurasian Economic Union





Manufacturer and Local Representative Information

Manufacturer information:

Hewlett Packard Enterprise Company, 1701 E Mossy Oaks Road, Spring, TX 77389 U.S.

Local representative information Russian:

- **Russia**
ООО "Хьюлетт Паккард Энтерпрайз", Российская Федерация, 125171, г. Москва, Ленинградское шоссе, 16А, стр.3, Телефон: +7 499 403 4248 Факс: +7 499 403 4677
- **Kazakhstan**
ТОО «Хьюлетт-Паккард (К)», Республика Казахстан, 050040, г. Алматы, Бостандыкский район, проспект Аль-Фараби, 77/7, Телефон/факс: + 7 727 355 35 50

Local representative information Kazakh:

- **Russia**
ЖШС "Хьюлетт Паккард Энтерпрайз", Ресей Федерациясы, 125171, Мәскеу, Ленинград тас жолы, 16А блок 3, Телефон: +7 499 403 4248 Факс: +7 499 403 4677
- **Kazakhstan**
ЖШС «Хьюлетт-Паккард (К)», Қазақстан Республикасы, 050040, Алматы к., Бостандық ауданы, Әл-Фараби даңғ ылы, 77/7, Телефон/факс: +7 727 355 35 50

Manufacturing date:

The manufacturing date is defined by the serial number.

CCSYWWZZZZ (product serial number format)

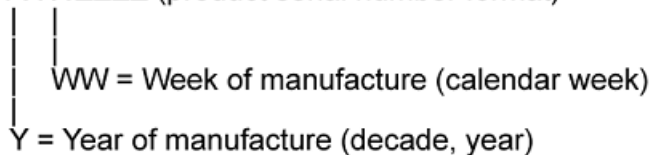

If you need help identifying the manufacturing date, contact tre@hpe.com.

Turkey RoHS material content declaration

Türkiye Cumhuriyeti: AEEE Yönetmeliğine Uygundur

Ukraine RoHS material content declaration

Обладнання відповідає вимогам Технічного регламенту щодо обмеження використання деяких небезпечних речовин в електричному та електронному обладнанні, затвердженого постановою Кабінету Міністрів України від 3 грудня 2008 № 1057

Warranty information



To view the warranty information for your product, see the [warranty check tool](#).

Specifications

Subtopics

[Environmental specifications](#)

[Mechanical specifications](#)

[Power supply specifications](#)

Environmental specifications

Specifications	Value
Temperature range*	—
Operating	10°C to 35°C (50°F to 95°F)
Nonoperating	-30°C to 60°C (-22°F to 140°F)
Relative humidity (noncondensing)	—
Operating	8% to 90% 28°C (82.4°F) maximum wet bulb temperature, noncondensing
Nonoperating	5% to 95% 38.7°C (101.7°F) maximum wet bulb temperature, noncondensing
Altitude	—
Operating	3050 m (10,000 ft) This value may be limited by the type and number of options installed. Maximum allowable altitude change rate is 457 m/min (1,500 ft/min).
Nonoperating	9144 m (30,000 ft) Maximum allowable altitude change rate is 457 m/min (1,500 ft/min).

Standard operating support

10°C to 35°C (50°F to 95°F) at sea level with an altitude derating of 1.0°C per every 305 m (1.8°F per every 1,000 ft) above sea level to a maximum of 3,050 m (10,000 ft), no direct sustained sunlight. Maximum rate of change is 20°C/hr (36°F/hr). The upper limit and rate of change may be limited by the type and number of options installed.

System performance during standard operating support might be reduced if operating above 30°C (86°F).

Extended ambient operating support

For approved hardware configurations, the supported system inlet range is extended to be:

- 5°C to 10°C (41°F to 50°F) and 35°C to 40°C (95°F to 104°F) at sea level with an altitude derating of 1.0°C per every 175 m (1.8°F per every 574 ft) above 900 m (2,953 ft) to a maximum of 3050 m (10,000 ft).
- 40°C to 45°C (104°F to 113°F) at sea level with an altitude derating of 1.0°C per every 125 m (1.8°F per every 410 ft) above 900 m (2953 ft) to a maximum of 3,050 m (10,000 ft).
- 45°C to 55°C (113°F to 131°F) at sea level with an altitude derating of 1.0°C per every 80 m (1.8°F per every 262 ft) above sea level.

The approved hardware configurations for this system are listed in the [Extended Ambient Temperature Guidelines for Gen11 HPE ProLiant](#)

servers:

<https://www.hpe.com/support/ASHRAEGen11>

Mechanical specifications

Specification	Value
Dimensions	—
Height	8.75 cm (3.44 in)
Depth	40.64 cm (16.00 in)
Width (without desktop installation hardware)	35.94 cm (14.15 in)
Width (with desktop installation hardware)	38.44 cm (15.13 in)
Weight, approximate values	—
Minimum, SFF (one drive, one DIMM, and one power supply installed)	9.83 kg (21.67 lb)
Maximum, SFF (two drives, six DIMMs, one boot device, and two power supplies installed, PCIe slots and OCP slot populated)	13.21 kg (29.12 lb)
Minimum, EDSFF (one drive, one DIMM, and one power supply installed)	9.76 kg (21.52 lb)
Maximum, EDSFF (six drives, six DIMMs, one boot device, and two power supplies installed, PCIe slots and OCP slot populated)	13.63 kg (30.05 lb)
Server and the desktop installation hardware (SFF, minimum)	11.81 kg (26.04 lb)
Server and the wall mount (SFF, minimum)	12.05 kg (26.57 lb)
Server and the rack mount (SFF, minimum)	11.38 kg (25.09 lb)
Server and the desktop installation hardware (SFF, maximum)	15.19 kg (33.49 lb)
Server and the wall mount (SFF, maximum)	15.43 kg (34.02 lb)
Server and the rack mount (SFF, maximum)	14.76 kg (32.54 lb)
Server and the desktop installation hardware (EDSFF, minimum)	11.74 kg (25.88 lb)
Server and the wall mount (EDSFF, minimum)	11.98 kg (26.41 lb)
Server and the rack mount (EDSFF, minimum)	11.31 kg (24.93 lb)
Server and the desktop installation hardware (EDSFF, maximum)	15.61 kg (34.41 lb)
Server and the wall mount (EDSFF, maximum)	15.85 kg (34.94 lb)
Server and the rack mount (EDSFF, maximum)	15.18 kg (33.47 lb)

Power supply specifications

Depending on the installed options and the regional location where the server was purchased, the server can be configured with one of the following power supplies. For detailed power supply specifications, see the QuickSpecs on the [Hewlett Packard Enterprise website](#).

Subtopics



HPE 700 W Flex Slot Platinum Hot-plug Power Supply

Specification	Value		
Rated input voltage	100 VAC to 240 VAC 4.1 A to 8.3 A at 50 Hz to 60 Hz		
Input voltage range (V_{RMS})	100 VAC to 240 VAC		
Nominal frequency range	50 Hz to 60 Hz		
Nominal input voltage	100 V_{RMS}	200 V_{RMS}	240 VDC
Maximum rated output	700 W	700 W	700 W
Maximum rated input	830 W	820 W	840 W
Maximum rated volt-ampere	780 VA	753 VA	840 VA



WARNING

To reduce the risk of electric shock or energy hazards:

- This equipment must be installed by trained service personnel.
- Connect the equipment to a reliably grounded secondary circuit source. A secondary circuit has no direct connection to a primary circuit and derives its power from a transformer, converter, or equivalent isolation device.

HPE 700 W Flex Slot -48 VDC Hot-plug Low Halogen Power Supply

Specification	Value
Input requirements	—
Rated input voltage	-40 VDC to -72 VDC -48 VDC nominal input
Rated input current	20 A maximum at -40 VDC
Rated input power	760 W at -40 VDC input 754 W at -48 VDC input, nominal input 744 W at -72 VDC input
Rated input power (BTUs per hour)	2593 at -40 VDC input 2572 at -48 VDC input, nominal input 2537 at -72 VDC input
Power supply output	—
Rated steady-state power	700 W at -40 VDC to -72 VDC
Maximum peak power	700 W at -40 VDC to -72 VDC

**WARNING**

To reduce the risk of electric shock or energy hazards:

- This equipment must be installed by trained service personnel.
- Connect the equipment to a reliably grounded secondary circuit source. A secondary circuit has no direct connection to a primary circuit and derives its power from a transformer, converter, or equivalent isolation device.

**CAUTION**

This equipment is designed to permit the connection of the earthed conductor of the DC supply circuit to the earthing conductor at the equipment.

If this connection is made, all of the following must be met:

- This equipment must be connected directly to the DC supply system earthing electrode conductor or to a bonding jumper from an earthing terminal bar or bus to which the DC supply system earthing electrode conductor is connected.
- This equipment must be located in the same immediate area (such as adjacent cabinets) as any other equipment that has a connection between the earthed conductor of the same DC supply circuit and the earthing conductor, and also the point of earthing of the DC system. The DC system must be earthed elsewhere.
- The DC supply source is to be located within the same premises as the equipment.
- Switching or disconnecting devices must not be in the earthed circuit conductor between the DC source and the point of connection of the earthing electrode conductor.

HPE 900 W–1000 W Flex Slot Titanium Hot-plug Power Supply



Specification	Value
Input requirements	—
Rated input voltage	100 VAC to 127 VAC 200 VAC to 240 VAC 240 VDC for China only
Rated input frequency	50 Hz to 60 Hz
Rated input current	10.2 A at 100 VAC 6.1 A at 200 VAC
Maximum rated input power	1010 W at 100 VAC 1090 W at 200 VAC
BTUs per hour	3446 at 100 VAC 3719 at 200 VAC
Power supply output	—
Rated steady-state power	900 W at 100 VAC to 127 VAC 1000 W at 200 VAC to 240 VAC input
Maximum peak power	900 W at 100 VAC to 127 VAC 1000 W at 200 VAC to 240 VAC

Websites

General websites

Single Point of Connectivity Knowledge (SPOCK) Storage compatibility matrix

<https://www.hpe.com/storage/spock>

Product white papers and analyst reports

<https://www.hpe.com/us/en/resource-library>

For additional websites, see [Support and other resources](#).

Product websites

HPE ProLiant DL145 Gen11 Server user documents

<https://www.hpe.com/info/dl145gen11-docs>

Support and other resources

Subtopics

[Accessing Hewlett Packard Enterprise Support](#)

[HPE product registration](#)

[Accessing updates](#)

[Customer self repair](#)

[Remote support](#)

Accessing Hewlett Packard Enterprise Support

- For live assistance, go to the Contact Hewlett Packard Enterprise Worldwide website:

<https://www.hpe.com/info/assistance>

- To access documentation and support services, go to the Hewlett Packard Enterprise Support Center website:

<https://www.hpe.com/support/hpesc>

Information to collect

- Technical support registration number (if applicable)
- Product name, model or version, and serial number
- Operating system name and version
- Firmware version
- Error messages
- Product-specific reports and logs
- Add-on products or components
- Third-party products or components

HPE product registration

To gain the full benefits of the Hewlett Packard Enterprise Support Center and your purchased support services, add your contracts and products to your account on the HPESC.

- When you add your contracts and products, you receive enhanced personalization, workspace alerts, insights through the dashboards, and easier management of your environment.
- You will also receive recommendations and tailored product knowledge to self-solve any issues, as well as streamlined case creation for faster time to resolution when you must create a case.

To learn how to add your contracts and products, see <https://www.hpe.com/info/add-products-contracts>.

Accessing updates

- Some software products provide a mechanism for accessing software updates through the product interface. Review your product documentation to identify the recommended software update method.
- To download product updates:

Hewlett Packard Enterprise Support Center

<https://www.hpe.com/support/hpesc>

My HPE Software Center

<https://www.hpe.com/software/hpesoftwarecenter>

- To subscribe to eNewsletters and alerts:

<https://www.hpe.com/support/e-updates>

- To view and update your entitlements, and to link your contracts and warranties with your profile, go to the Hewlett Packard Enterprise Support Center More Information on Access to Support Materials page:

<https://www.hpe.com/support/AccessToSupportMaterials>



IMPORTANT

Access to some updates might require product entitlement when accessed through the Hewlett Packard Enterprise Support Center. You must have an HPE Account set up with relevant entitlements.

Customer self repair

Hewlett Packard Enterprise customer self repair (CSR) programs allow you to repair your product. If a CSR part needs to be replaced, it will be shipped directly to you so that you can install it at your convenience. Some parts do not qualify for CSR.

For more information about CSR, contact your local service provider.

Remote support

Remote support is available with supported devices as part of your warranty or contractual support agreement. It provides intelligent event diagnosis, and automatic, secure submission of hardware event notifications to Hewlett Packard Enterprise, which initiates a fast and accurate resolution based on the service level of your product. Hewlett Packard Enterprise strongly recommends that you register your device for remote support.

If your product includes additional remote support details, use search to locate that information.

HPE Get Connected

<https://www.hpe.com/services/getconnected>

HPE Tech Care Service

<https://www.hpe.com/services/techcare>

HPE Complete Care Service

<https://www.hpe.com/services/completecure>

Documentation feedback

Hewlett Packard Enterprise is committed to providing documentation that meets your needs. To help us improve the documentation, use the Feedback button and icons (at the bottom of an opened document) on the Hewlett Packard Enterprise Support Center portal (<https://www.hpe.com/support/hpesc>) to send any errors, suggestions, or comments. This process captures all document information.

