



## **Cisco Catalyst IW9165E Rugged Access Point and Wireless Client Hardware Installation Guide**

**First Published:** 2023-09-24

**Last Modified:** 2024-01-15

### **Americas Headquarters**

Cisco Systems, Inc.  
170 West Tasman Drive  
San Jose, CA 95134-1706  
USA  
<http://www.cisco.com>  
Tel: 408 526-4000  
800 553-NETS (6387)  
Fax: 408 527-0883





## CONTENTS

---

### PREFACE

<b>Preface</b>	<b>vii</b>
About this Guide	vii
Conventions	vii
Related Documentation	viii
Communications, Services, and Additional Information	viii
Cisco Bug Search Tool	viii
Documentation Feedback	viii

---

### CHAPTER 1

<b>About Cisco Catalyst IW9165E Rugged Access Point and Wireless Client</b>	<b>1</b>
Introduction to Cisco Catalyst IW9165E Rugged Access Point and Wireless Client	1
Cisco Catalyst IW9165E Features	1
Connectors and Ports	2
Digital I/O Connector	3
4-Pin Micro-Fit Connector for DC Power	5
M12-RJ45 Adapter	6
Power Sources	6
Power Adapters	7
Power Injectors	7
Ethernet (PoE) Ports	7
Antennas and Radios	7
Supported External Antennas	8

---

### CHAPTER 2

<b>Unpacking Your Access Point</b>	<b>11</b>
Package Contents	11
Unpacking the Access Point	11
Cisco Orderable Accessories	11

---

<b>CHAPTER 3</b>	<b>Installation Overview</b>	<b>15</b>
	Preinstallation Checks and Installation Guidelines	15
	Mounting the Access Point	16
	Mounting on a Wall	16
	Installing a DIN Rail	19
	Mounting the DIN Rail Bracket on the Access Point	20
	Attaching the Bracket onto the DIN Rail	21
	Grounding the Access Point	23
	Powering the Access Point	25
	Power Feature Matrix	25
	Connecting a Power Injector	25
	Connecting a DC Power Cable to the Access Point	26
	Connecting an Ethernet Cable to the Access Point	26
	Connecting an Ethernet Cable to the Access Point	27
	Connecting to the RJ-45 Port Using M12 Adapter	27

---

<b>CHAPTER 4</b>	<b>Troubleshooting</b>	<b>31</b>
	Using the Reset Button	31
	Checking the Access Point LEDs	31

---

<b>CHAPTER 5</b>	<b>Safety Guidelines and Warnings</b>	<b>35</b>
	Safety Instructions	35
	FCC Safety Compliance Statement	36
	Safety Precautions	36
	Safety Precautions when Installing Antennas	37
	Avoiding Damage to Radios in a Testing Environment	37
	Performing Site Surveys	38

---

<b>CHAPTER 6</b>	<b>Declarations of Conformity and Regulatory Information</b>	<b>41</b>
	Manufacturers Federal Communications Commission Declaration of Conformity Statement	41
	Operation of Cisco Catalyst Access Points in México	42
	VCCI Statement for Japan	42
	Statement 191—Voluntary Control Council for Interference (VCCI) Class A Warning for Japan	42

ステートメント 191—日本向け VCCI クラス A に関する警告	43
Guidelines for Operating Cisco Catalyst Access Points in Japan	43
Compliance Statement for Canada	44
Industry Canada	44
European Community, Switzerland, Norway, Iceland, and Liechtenstein	45
United Kingdom Compliance	45
Declaration of Conformity for RF Exposure	46
Generic Discussion on RF Exposure	46
This Device Meets International Guidelines for Exposure to Radio Waves	46
This Device Meets FCC Guidelines for Exposure to Radio Waves	47
This Device Meets the Industry Canada Guidelines for Exposure to Radio Waves	47
Cet appareil est conforme aux directives internationales en matière d'exposition aux fréquences radioélectriques	48
Additional Information on RF Exposure	48
Declaration of Conformity Statements	48





## Preface

---

This preface describes this guide and provides information about the conventions used in this guide, and related documentation.

It includes the following sections:

- [About this Guide, on page vii](#)
- [Conventions, on page vii](#)
- [Related Documentation, on page viii](#)
- [Communications, Services, and Additional Information, on page viii](#)

## About this Guide

This guide provides instructions to install your Cisco Access Point and provides links to resources that can help you configure it. This guide also provides mounting instructions and troubleshooting information.

## Conventions

This document uses the following conventions for notes, cautions, and safety warnings. Notes and cautions contain important information that you should know.



---

**Note** Means *reader take note*. Notes contain helpful suggestions or references to material not covered in the manual.

---



---

**Caution** Means *reader be careful*. Cautions contain information about something you might do that could result in equipment damage or loss of data.

---



---

**Warning** Safety warnings appear throughout this guide in procedures that, if performed incorrectly, can cause physical injuries. A warning symbol precedes each warning statement.

---

## Related Documentation

All user documentation for the Cisco Catalyst IW9165 Rugged Series is available at the following URL:

<https://www.cisco.com/c/en/us/support/wireless/catalyst-iw9165-rugged-series/series.html>

For detailed information and guidelines about configuring and deploying your access point in a wireless network, see the relevant release of Wireless Controller configuration guide at the following URL:

<https://www.cisco.com/c/en/us/support/wireless/catalyst-9800-series-wireless-controllers/products-installation-and-configuration-guides-list.html>

## Communications, Services, and Additional Information

- To receive timely, relevant information from Cisco, sign up at [Cisco Profile Manager](#).
- To get the business impact you're looking for with the technologies that matter, visit [Cisco Services](#).
- To submit a service request, visit [Cisco Support](#).
- To discover and browse secure, validated enterprise-class apps, products, solutions, and services, visit [Cisco DevNet](#).
- To obtain general networking, training, and certification titles, visit [Cisco Press](#).
- To find warranty information for a specific product or product family, access [Cisco Warranty Finder](#).

## Cisco Bug Search Tool

[Cisco Bug Search Tool](#) (BST) is a gateway to the Cisco bug-tracking system, which maintains a comprehensive list of defects and vulnerabilities in Cisco products and software. The BST provides you with detailed defect information about your products and software.

## Documentation Feedback

To provide feedback about Cisco technical documentation, use the feedback form available in the right pane of every online document.





# CHAPTER 1

## About Cisco Catalyst IW9165E Rugged Access Point and Wireless Client

---

- [Introduction to Cisco Catalyst IW9165E Rugged Access Point and Wireless Client, on page 1](#)
- [Cisco Catalyst IW9165E Features, on page 1](#)
- [Connectors and Ports, on page 2](#)
- [Power Sources, on page 6](#)
- [Antennas and Radios, on page 7](#)

## Introduction to Cisco Catalyst IW9165E Rugged Access Point and Wireless Client

The Cisco Catalyst IW9165E Rugged Access Point and Wireless Client (hereafter referred to as *IW9165E*) is designed to add ultrareliable wireless connectivity to moving vehicles and machines. The IW9165E runs [Cisco Ultra-Reliable Wireless Backhaul \(Cisco URWB\)](#), which delivers high availability, low latency, and zero packet loss with seamless handoffs.

The IW9165E can also operate as a Wi-Fi client in Workgroup Bridge (WGB) mode, which allows it to connect to a Cisco access point infrastructure, and Universal WGB (uWGB) mode, which allows it to connect to a third-party access point infrastructure. Both of these modes help bridge the wired clients that are behind the WGB to the access point on the infrastructure side.

A full listing of the AP's features and specifications is provided in the [Cisco Catalyst IW9165 Series Data Sheet](#).

## Cisco Catalyst IW9165E Features

Cisco Catalyst IW9165E Rugged Access Point and Wireless Client has the following features:

- 1x 100M/1000M/2.5G Multigigabit Ethernet (RJ45)/M12 X-code autosensing PoE+ in (802.3af/at), Cisco UPOE in
- 1x 100M/1000M/1G (RJ45)
- Dual-radio architecture
  - 5-GHz 2x2 radio: 20, 40, and 80 MHz channels

- 5/6-GHz 2x2 radio: 20, 40, 80, and 160 MHz channels (6 GHz availability subject to country approvals)
- External antenna—4 x RP-SMA
- 1x SMA GNSS antenna port—A built-in GNSS (Global Navigation Satellite System) receiver provides coordinates to track the location of the access point.
- 1x GPIO ports—A 3-pin GPIO (general-purpose input output) enables control of external contacts.
- Management console port (RJ45)
- Dual power input—PoE-in 802.3af, 802.3at (PoE+), POE+ and 24-48VDC
- Dual mounting options—DIN rail and wall mount
- IP30, EN50155
- Multicolor system LED, Received signal strength indicator (RSSI) LED, Port LED
- Reset button

## Connectors and Ports

The following figure shows the available ports on the right-side panel of IW9165E.

**Figure 1: IW9165E Right-Side Panel**

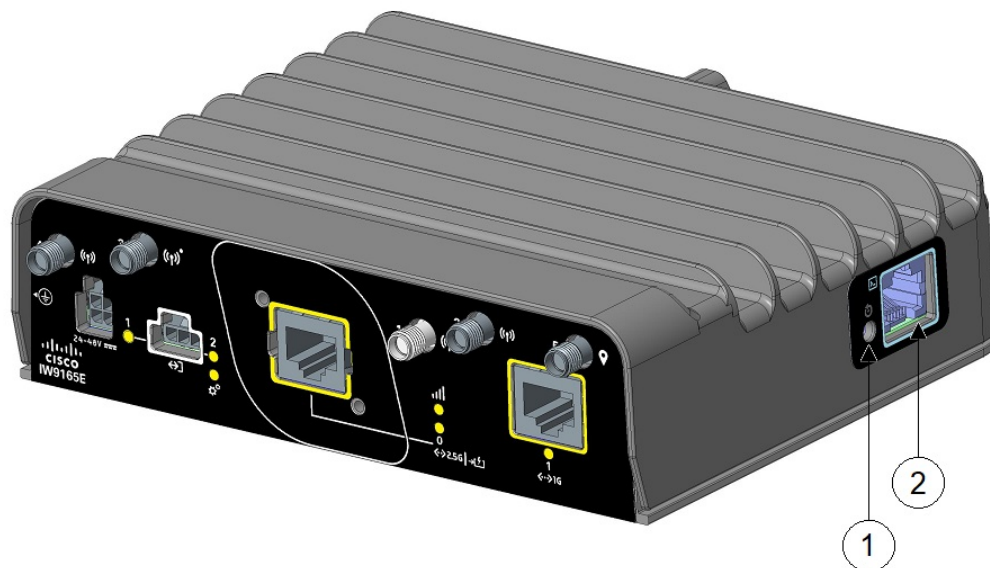

1	Reset button	2	Console port (RJ-45)
---	--------------	---	----------------------

The following figure shows the available ports on the AP front panel.

Figure 2: IW9165E Front Panel

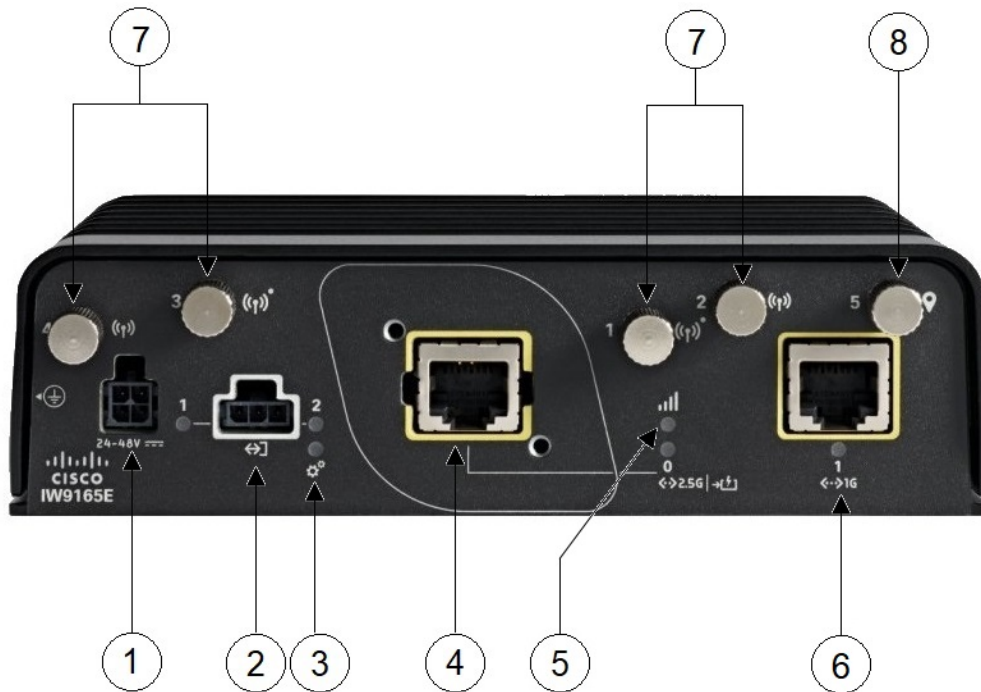

1	DC power input	5	RSSI Status LED
2	2 GPIO + 1 Return (Digital I/O) <b>Note</b> Digital I/O will be supported in a future software release.	6	100M/1000M/1G (RJ45)
3	System Status LED	7	Antenna ports <ul style="list-style-type: none"> <li>• Antenna 1: 5 GHz and IoT radio</li> <li>• Antenna 2: 5 GHz</li> <li>• Antennas 3 and 4: 5/6 GHz</li> </ul>
4	100M/1000M/2.5G Multigigabit Ethernet (RJ45)/M12 X-code autosensing PoE+ in (802.3af/at), Cisco UPOE in	8	GNSS port

## Digital I/O Connector

The Digital I/O connector has 2 GPIO connections plus 1 Return connection. The Digital I/O supports Dry contacts.

Dry contact is isolated from a voltage source (or “No Volt”), with an embedded relay function (NPN transistor), usually used to indicate an event. For example: open/close, alarm.

The following graphic shows the connector.



**Note** The default state of the Digital I/O is input, the open-collector is open (off).

**Figure 3: Digital I/O connector**

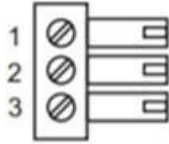

The pinouts for the Digital I/O are described in the following table.

**Table 1: Digital I/O Pinouts**

Pin #	Name	Direction	Description
1	DIO1	I/O	Digital IO 1
2	Return	Return	Digital IO Common Return
3	DIO2	I/O	Digital IO 2

Digital Input and Output Specifications are described in the following tables.

Digital Input Specification is considered “dry contact”.

**Table 2: Digital Input Specification**

Specification	Minimum	Maximum	Unit
Input Voltage High	2.5	60	Volts
Input Voltage Low	—	1.2	Volts
Input Current	—	12 <sup>1</sup>	mA

<sup>1</sup> Current is flowing out of the terminal although it is an input, i.e. sourcing. The current is flowing in the terminal for the output, i.e. sinking.

**Table 3: Digital Output Specification**

Specification	Minimum	Maximum	Unit	Notes
Output Voltage High	2.5	—	Volts	No external voltage applied.
Output Voltage Low	—	0.4	Volts	No external voltage applied.
Internal Pull-up Resistance	220 – 1%	220 + 1%	Ohms	—

Specification	Minimum	Maximum	Unit	Notes
Internal Pull-up Voltage	—	3	Volts	—
External Pull-up Voltage	3.3	60	Volts	External resistance required to limit current to less than 100mA.
Sink Current	—	100	mA	—

Common features of the Digital I/O are:

- Withstands up to 60V applied at the terminal.
- Reverse voltage protected and causes no damage to the equipment.
- Digital input and output can coexist on different channel.
- LED Indicator: provision-able, On: Active, Off: Non-active.
- Electrical isolation: 2000 VDC.
- 4kV Surge protected (IEC 61000-4-5).

## 4-Pin Micro-Fit Connector for DC Power

The following figure shows the 4-pin Micro-Fit connector for DC power.

*Figure 4: Mating Connector Front View*

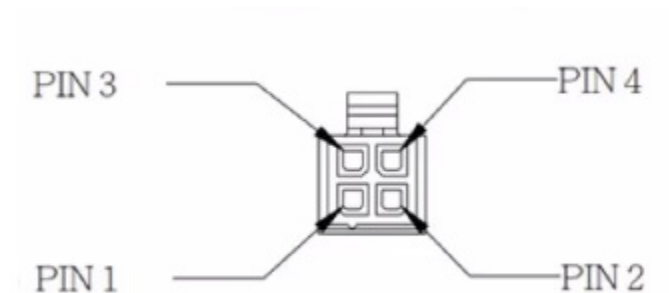

Molex Micro-Fit Pin	Assignment
Pin 1	Black ( - Negative Terminal)
Pin 2	Not assigned
Pin 3	White (+ Positive Terminal)
Pin 4	Not assigned

## M12-RJ45 Adapter

M12-RJ45 adapter (Cisco PID: IW-ACC-M12ETH=) can be used to support M12 X-coded connector.



**Note** M12 X-code port by using M12-RJ45 adapter can support up to 2.5G rate.



**Note** The M12 spacer (Cisco PID: IW-ACC-M12SPCR2= ) is required when using the M12 adapter.

*Figure 5: M12-RJ45 Adapter (Cisco PID: IW-ACC-M12ETH=)*

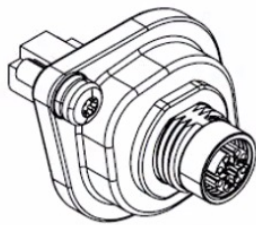

The following table shows the M12-RJ45 adapter pinouts.

*Table 4: M12-RJ45 Pinouts*

RJ45	Signal	M12 X-Code
1	B1_DA+	1
2	B1_DA-	2
3	B1_DB+	3
6	B1_DB-	4
7	B1_DD+	5
8	B1_DD-	6
5	B1_DC-	7
4	B1_DC+	8

## Power Sources

The IW9165E is supported on these power sources:

- DC power: 24 to 48 VDC
- Power over Ethernet (PoE): 802.3at (PoE+), 802.3bt (PoE++), Cisco Universal PoE (Cisco UPOE).

**Warning**

Connect the unit only to DC power source that complies with the safety extra-low voltage (SELV) requirements in IEC 60950 based safety standards. Statement 1033

## Power Adapters

The IW9165E supports the following DC power adapters::

- PID: IW-PWRADPT-MFIT4P=: Operating: -40°C to +65°C, 60W.

## Power Injectors

The IW9165E supports the following power injectors:

- IW-PWRINJ-60RGDMG=: Operating: -40°C to +70°C. Power derating of 60W at 70°C, and 65W at 65°C. Supports 100M/1G/2.5G/5G/10G rates.

**Caution**

When the AP is installed outdoors or in a wet or damp location, the AC branch circuit powering the AP should be provided with ground fault protection (GFCI), as required by Article 210 of the National Electrical Code (NEC).

## Ethernet (PoE) Ports

The AP supports an Ethernet uplink port (also for PoE-IN). The Ethernet uplink port on the AP uses an RJ-45 connector to link the AP to the 100BASE-T, 1000BASE-T, or 2.5G BASE-T network. The Ethernet cable is used to send and receive Ethernet data and optionally supply inline power from the power injector or a suitably powered switch port.

**Tip**

The AP senses the Ethernet and power signals, and automatically switch internal circuitry to match the cable connections.

The Ethernet cable must be a *shielded*, Category 5e (CAT 5e) or better cable. The AP senses the Ethernet and power signals and automatically switches internal circuitry to match the cable connections.

## Antennas and Radios

The Cisco Catalyst IW9165E Rugged Access Point and Wireless Client configuration is:

- IW9165E-x

The IW9165E access point has four RP-SMA jack connectors to support multiple antenna options, such as the self-identifying antennas (SIA) on designated two SIA ports, dual-band antennas, and single-band antennas. To see the list of supported antennas and the radio bands they operate at, see [Supported External Antennas, on page 8](#).

## Supported External Antennas

The following figure shows the antenna ports of the IW9165E access point.

Figure 6: IW9165E Antenna Ports

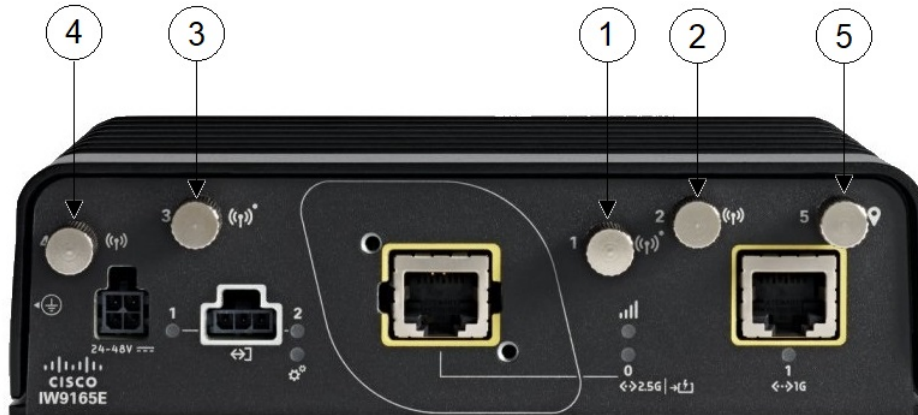

1	Port 1 Supports 5 GHz in 2x2 mode. Supports Bluetooth Low Energy (BLE) radio. Supports SIA.	4	Port 4 Supports 5/6 GHz radio in 2x2 mode.
2	Port 2 Supports 5 GHz radio in 2x2 mode.	5	GNSS port
3	Port 3 Supports 5/6 GHz radio in 2x2 mode. Supports SIA.		



**Note** If omnidirectional antennas are connected to either radio, the antennas of each radio must be spaced at least 3 ft. (1 m) apart vertically to avoid interference between the two radios.

If directional antennas are connected to both radios, space them at least 10 ft. (3 m) apart vertically, or at least 5 ft. (1.5 m) apart horizontally with their main beams aimed at least 90 degrees apart.

If two independent omnidirectional antennas are connected to both ports of either radio (both ports 1 and 2 or ports 3 and 4), space them at least 2.5 in. (6 cm) apart for best performance.

### Supported Wi-Fi Antennas

The following table shows the external Wi-Fi antennas supported by IW9165E.



Table 5: Supported Wi-Fi Antennas

PID	Antenna Gain (dBi)			Connector	Antenna Name
	2.4 GHz	4.9 GHz	5 GHz		
IW-ANT-PNL-515-N=	—	15	15	N female (x2)	Cisco 5 GHz 15 dBi Dual-Port Polarization Diverse Directional Panel Antenna
IW-ANT-OMV-2567-N=	4	7	7	N male	2.4/5 GHz Tri-Band Omnidirectional Dipole Antenna, Vertically Polarized, Self-Identifying
IW-ANT-OMH-2567-N=	4	7	7	N male	2.4/5 GHz Tri-Band Omnidirectional Dipole Antenna, Horizontally Polarized, Self-Identifying
AIR-ANT2547V-N=	4	—	7	N male	Cisco Aironet Dual-Band Omnidirectional Dipole Antenna (White)
AIR-ANT2547VG-N=	4	—	7	N male	Cisco Aironet Dual-Band Omnidirectional Dipole Antenna (Gray)
AIR-ANT2547VG-NS=	4	—	7	N male	Cisco Aironet Dual-Band Omnidirectional Dipole Antenna (Gray), Self-Identifying
AIR-ANT2568VG-N=	6	—	8	N male	Cisco Aironet Dual-Band Omnidirectional Dipole Antenna (Gray)
AIR-ANT2568VG-NS=	6	—	8	N male	Cisco Aironet Dual-Band Omnidirectional Dipole Antenna (Gray), Self-Identifying
AIR-ANT5180V-N=	—	7	8	N male	Cisco Aironet 5 GHz 8 dBi Omnidirectional Dipole Antenna
AIR-ANT2588P4M-NS=	9.1 (V), 7.1 (H)	—	9.6 (V), 7.8 (H)	N female (x4)	Cisco Aironet 2.4/5 GHz 8 dBi 4-Element Dual-Polarized Patch Antenna, Self-Identifying
AIR-ANT5114P2M-N=	—	—	13	N male (x2)	Cisco Aironet 5 GHz 13 dBi Dual-Port Dual-Polarized Directional Panel Antenna
AIR-ANT2513P4M-N=	13	—	13	N female (x4)	Cisco Aironet Four-Port Dual-Band Polarization-Diverse Directional Panel Antenna

PID	Antenna Gain (dBi)			Connector	Antenna Name
	13	—	13		
AIR-ANT2513P4M-NS=	13	—	13	N female (x4)	Cisco Aironet Four-Port Dual-Band Polarization-Diverse Directional Panel Antenna, Self-Identifying

For installation instructions and detailed information on any of these antennas, refer to the antenna data sheet on Cisco.com, or see the antenna guides at:

- [Cisco Industrial Routers and Industrial Wireless Access Points Antenna Guide](#)
- <http://www.cisco.com/c/en/us/support/wireless/aironet-antennas-accessories/products-installation-guides-list.html>

Follow all safety precautions when installing the antennas. For information on safety, see [Safety Precautions when Installing Antennas](#), on page 37.

### Supported URWB Antennas

The following table shows the URWB antennas supported by IW9165E.

**Table 6: Supported URWB Antennas**

PID	Antenna Gain (dBi)			Connector	Antenna Name
	2.4 GHz	4.9 GHz	5 GHz		
IW-ANT-OMM-53-N=	—	3	3	N female	5 GHz Omnidirectional Multi-Polarized Antenna
IW-ANT-PNL-59-N=	—	—	9	N female (x2)	5 GHz Dual-Port Dual-Slant +/-45 Degree Polarized Directional Panel Antenna
IW-ANT-SKS-514-Q=	—	14	14	QMA female (x2)	5 GHz Directional Shark Antenna, Dual-Slant +/-45 Degree Polarized
IW-ANT-SKD-513-Q=	—	13	13	QMA female (x2)	5 GHz Bidirectional Shark Antenna, Dual-Slant +/-45 Degree Polarized

### Supported GNSS Antenna

The following table shows the external GNSS antennas supported by IW9165E.

**Table 7: Supported GNSS Antenna**

PID	Frequencies Supported	Connector	Description
ANT-GNSS-OUT-TNC=	1560 - 1608 MHz	TNC male	Outdoor Active GNSS Antenna with 15-ft. integrated cable
IW-ANT-GNSS-SMA=	1559 - 1610 MHz	SMA male	Indoor/outdoor active GNSS antenna with 10-ft. integrated cable



## CHAPTER 2

# Unpacking Your Access Point

---

- [Package Contents, on page 11](#)
- [Unpacking the Access Point, on page 11](#)
- [Cisco Orderable Accessories, on page 11](#)

## Package Contents

Each AP package contains the following items:

- One IW9165E AP
- Ground lug kit

## Unpacking the Access Point

To unpack the AP, follow these steps:

- 
- Step 1** Unpack and remove the access point and the selected mounting accessory kit from the shipping box.
  - Step 2** Return the packing material to the shipping container and save it for future use.
  - Step 3** Verify that you have received all items ordered. If any item is missing or damaged, contact your Cisco representative or reseller for instructions.
- 

## Cisco Orderable Accessories

Order the following accessories separately from Cisco:

- AP mounting brackets

Cisco PID	Description
IR1101-DINRAIL=	DIN rail mounting bracket

Cisco PID	Description
IR1101-WALLMNT=	Wall mounting bracket

- Accessory kits

Cisco PID	Description
IW-ACC-M12ETH=	Adapter, M12 X-code to RJ45 Ethernet connector
IW-ACC-M12PWR=	Adapter, M12 4 Pin A-Code to Micro-fit power connector
IW-ACC-M12SPCR2=	Spacer for M12 (Qty: 5)

- M12 Cables

Cisco PID	Description
CAB-PWR-M12-10=	M12 DC power cable, 4 pins, A-Code, 10 ft
CAB-RJ45-M12-10=	M12 to RJ-45 Ethernet cable, 8 pins, X-Code, 10 ft

- RF Coaxial Adapters

Cisco PID	Description
AIR-ACC370-NF-NF=	N(f) to N(f) RF adapter DC-11 GHz
LTE-ADPT-SM-TF=	SMA(m) to TNC(f) RF adapter, DC-11 GHz

- RF Coaxial Cables

Cisco PID	Description
CAB-L400-5-N-N=	5 ft. LMR-400-DB, N(m)-STR to N(m)-R/A
CAB-L400-5-N-NS=	5 ft. LMR-400-DB, N(m)-STR to N(m)-STR
AIR-CAB010LL-N=	10 ft. LMR-400-DB, N(m)-STR to N(m)-STR
CAB-L400-20-N-N=	20 ft. LMR-400-DB, N(m)-STR to N(m)-RA
AIR-CAB025HZ-N=	25 ft. LMR-400-DB/FR/CMR, N(m)-STR to N(m)-RA
CAB-L600-30-N-N=	30 ft. LMR-600-DB, N(m)-STR to N(m)-RA
CAB-L240-10-Q-N=	10 ft. LMR-240-FR/CMR, N(m)-STR to QMA(m)-RA
CAB-L240-15-Q-N=	15 ft. LMR-240-FR/CMR, N(m)-STR to QMA(m)-RA
CAB-L240-20-Q-N=	20 ft. LMR-240-FR/CMR, N(m)-STR to QMA(m)-RA

- Power adapter and power injectors when PoE is not available

<b>Power Supply</b>	<b>Description</b>
IW-PWRADPT-MFIT4P=	Power Adapter, AC-DC, Micro-Fit 4-Pin connector
IW-PWRINJ-60RGDMG=	Power Injector, 60W, outdoor 5GE





## CHAPTER 3

# Installation Overview

---

- [Preinstallation Checks and Installation Guidelines, on page 15](#)
- [Mounting the Access Point, on page 16](#)
- [Grounding the Access Point, on page 23](#)
- [Powering the Access Point, on page 25](#)
- [Connecting an Ethernet Cable to the Access Point, on page 26](#)

## Preinstallation Checks and Installation Guidelines

Before you mount and deploy your access point, we recommend that you perform a site survey (or use the Site Planning tool) to determine the best location to install your access point.

You should have the following information about your wireless network available:

- Access point locations
- Access point mounting options: To a vertical or horizontal wall or a DIN rail
- Access point power options: Use either of the following options to power the AP:
  - DC power input
  - Cisco-approved power injector
  - 802.3at (PoE+), 802.3bt, and Cisco Universal PoE (Cisco UPOE)
- Operating temperature: -40° to +158°F (-40° to +70°C) with still air.
- Console access using the console port

We recommend that you use a console cable that is one meter or less in length.



---

**Note** The AP may face issues while booting if you use an unterminated console cable (not plugged into any device or terminal) or a console cable that is more than one meter in length.

---

We recommend that you make a site map showing access point locations so that you can record the device MAC addresses from each location and return them to the person who is planning or managing your wireless network.

## Mounting the Access Point

This section provides instructions to mount the AP.



**Note** Personnel mounting the AP must have knowledge of the wireless AP, bridging techniques, and grounding methods.

The IW9165E AP can be mounted in a vertical or horizontal orientation. It can be mounted to a wall or other flat surface, and can also be mounted to a DIN rail.

You can attach the AP directly into your own mounting bracket by using the mounting holes on the bottom of the AP.

The following figure provides the mounting hole layout and dimensions (inch).

**Figure 7: Dimensions of Mounting Holes on the Bottom of AP**

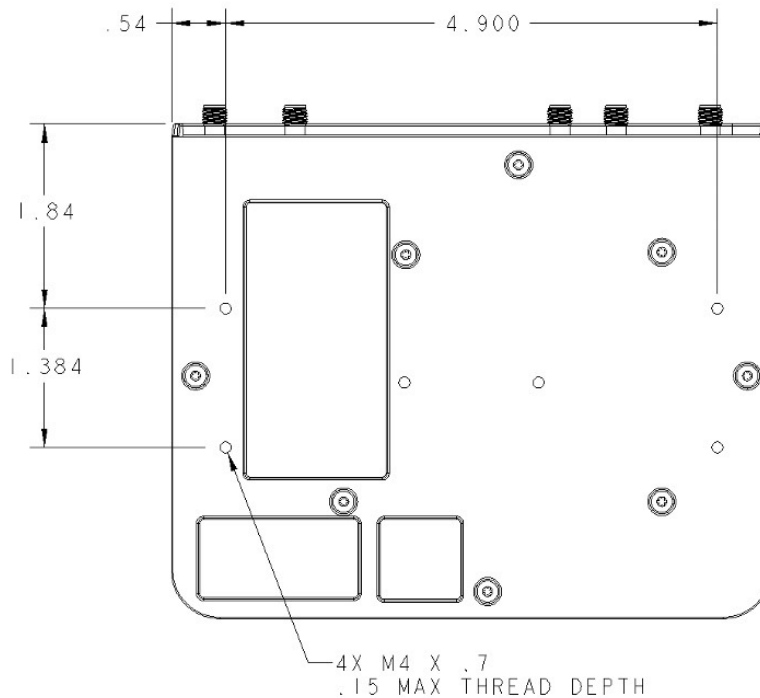

## Mounting on a Wall

The wall mounting kit contains the following:

- Mounting brackets (x2)



- Mounting screws (x4) M4 x 6mm



**Tip** When choosing a location for wall-mounting an access point, consider cable limitations and wall structure, and consider suitable antenna location ahead of time.



**Warning** Read the wall-mounting instructions carefully before beginning installation. Failure to use the correct hardware or to follow the correct procedures could result in a hazardous situation to people and damage to the system. Statement 1094



**Warning** A minimum of 1 inch clearance is required on all sides of the device except for the side mounted against the wall or DIN rail, to allow for proper air flow.

To mount the access point on a wall or other flat surface, follow these steps:

**Step 1** Attach the mounting brackets to the bottom of the access point.

*Figure 8: IW9165E Mounting Brackets*

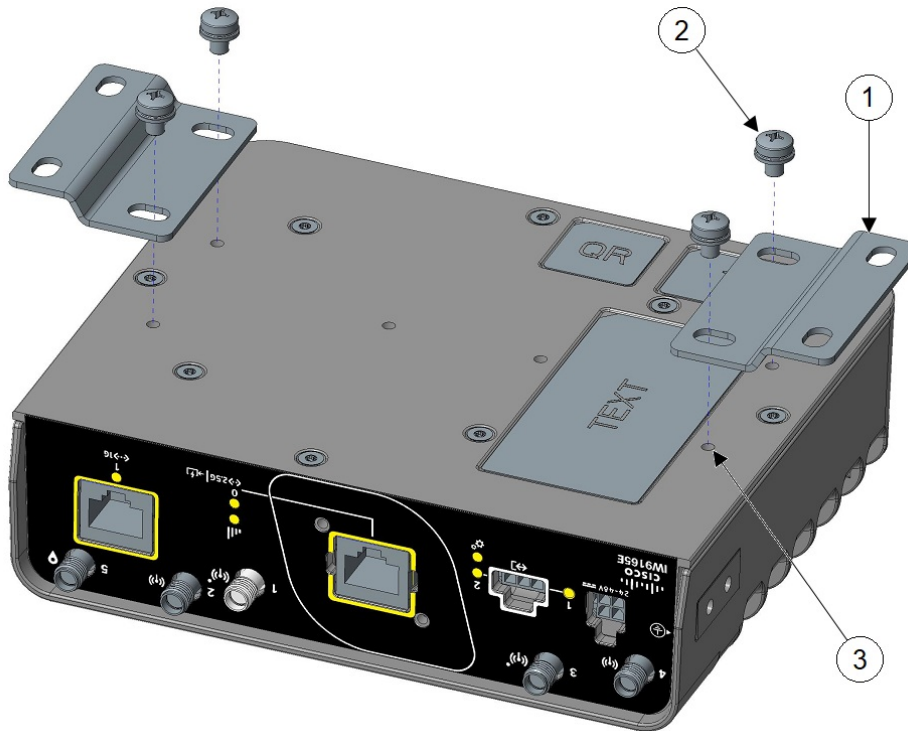

1	Mounting brackets
---	-------------------

2	M4 screws from kit
3	Mounting holes

**Step 2** Align the mounting brackets (1) over the mounting holes (3) so that the larger holes on the brackets extend out over the access point.

**Step 3** Attach the brackets to the access point with the four M4 screws (2) provided using a Phillips head driver. Torque to 12-15 in-lbs.

**Figure 9: IW9165E With Mounting Brackets Attached**

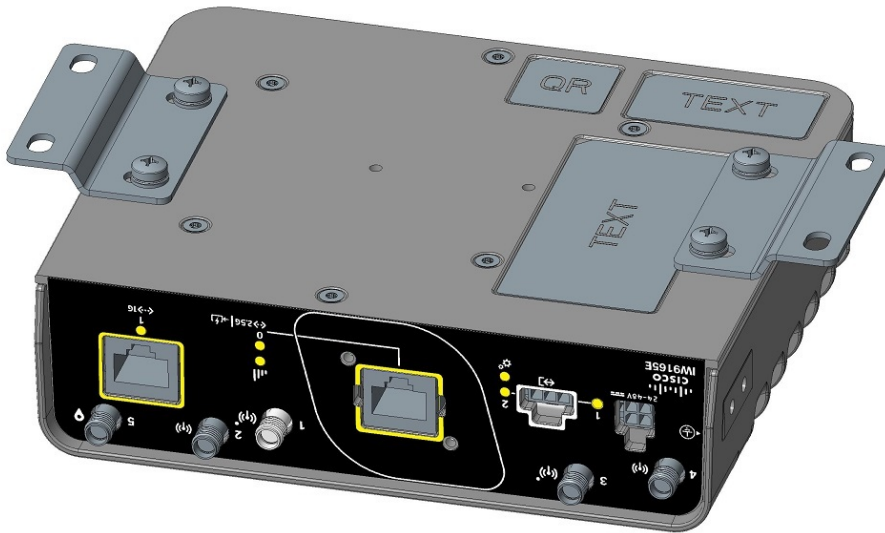

**Step 4** Mount the access point with the attached brackets in a proper wall structure to carry the weight of the device. See the following for the dimensions of the mounting holes with the brackets attached to the access point.

**Figure 10: Wall Mounting Hole Dimensions and Overall Dimensions With Mounting Brackets Attached**

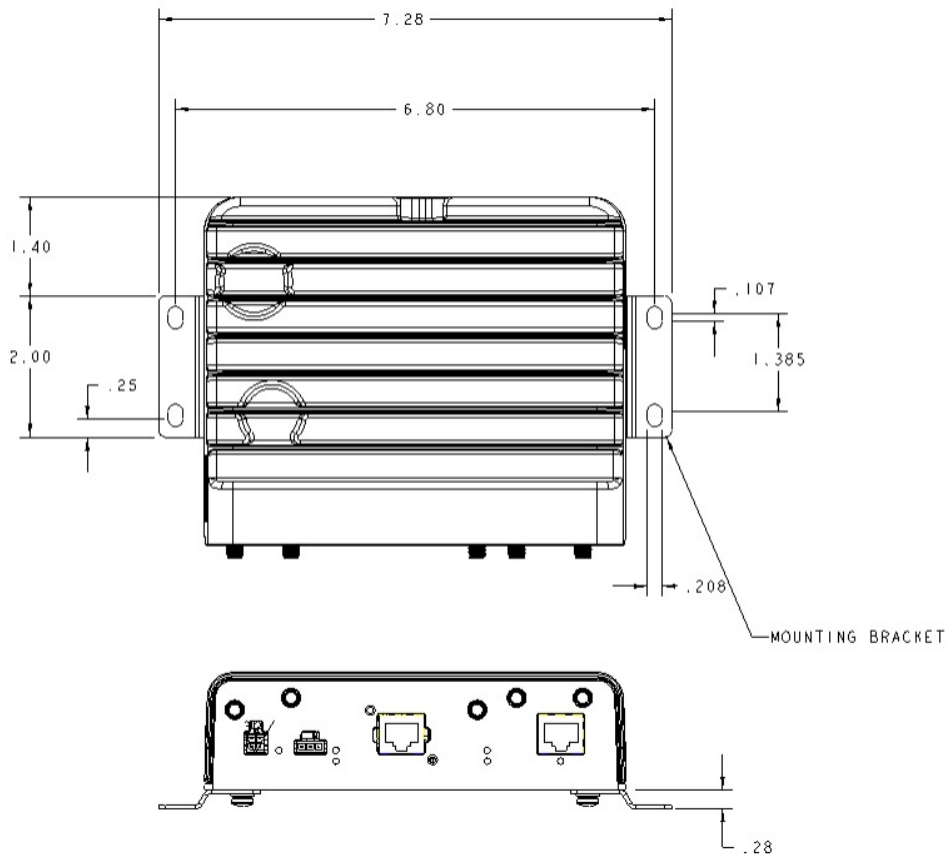

**Step 5** Route the cables so that they do not put a strain on the connectors or mounting hardware.

## Installing a DIN Rail

The DIN Rail kit is ordered separately.



**Note** The DIN Rail can be installed on the IW9165E in two different orientations, horizontally and vertically.



**Warning** A minimum of 1 inch clearance is required on all sides of the device except for the side mounted against the wall or DIN rail, to allow for proper air flow.

To attach the DIN rail bracket to the IW9165E, follow these steps.

## Mounting the DIN Rail Bracket on the Access Point

- Step 1** First, attach the DIN rail bracket to the back of the access point. The DIN rail bracket can be attached to the bottom or the back of the access point. For back mounting, there are two ways to attach the bracket.
- Step 2** Attach the DIN mounting bracket to the access point using the two screws provided in the kit. Position the bracket over the two mounting holes that correspond to your orientation. Use 12-15 in-lbs. of torque to screw the bracket onto the access point.

**Figure 11: Attaching the DIN Rail Bracket**

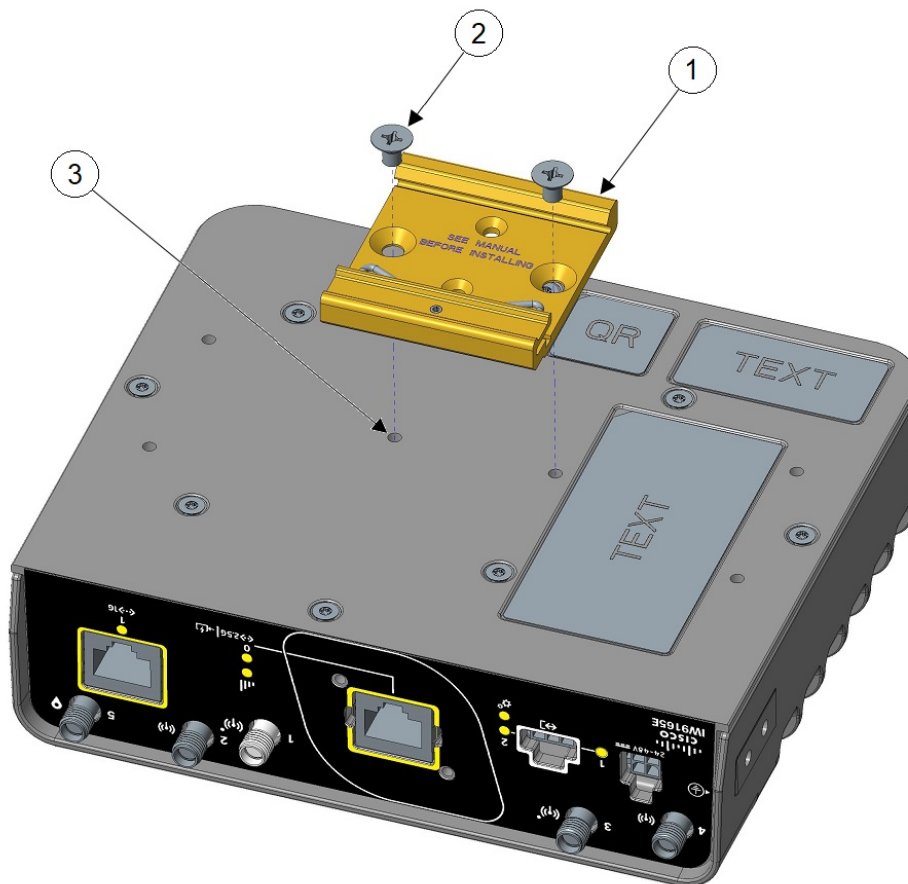

1	DIN mounting bracket
2	M4 screws from kit
3	Mounting holes

- Step 3** Once the bracket is attached to the access point, it can be mounted onto the DIN Rail.

**Figure 12: DIN Rail Bracket Mounted on the Bottom**

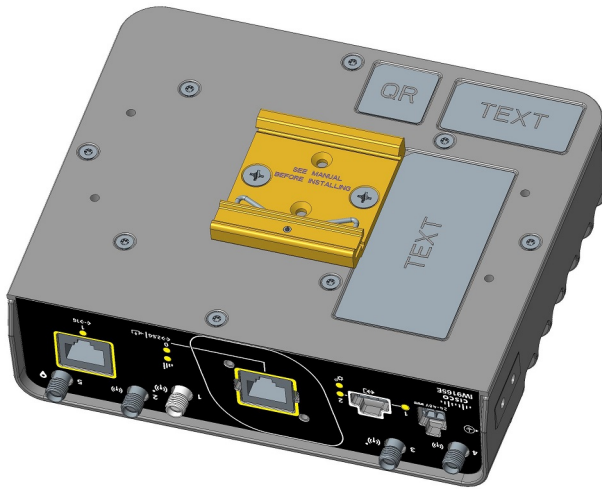

**Figure 13: DIN Rail Bracket Mounted on the Back**

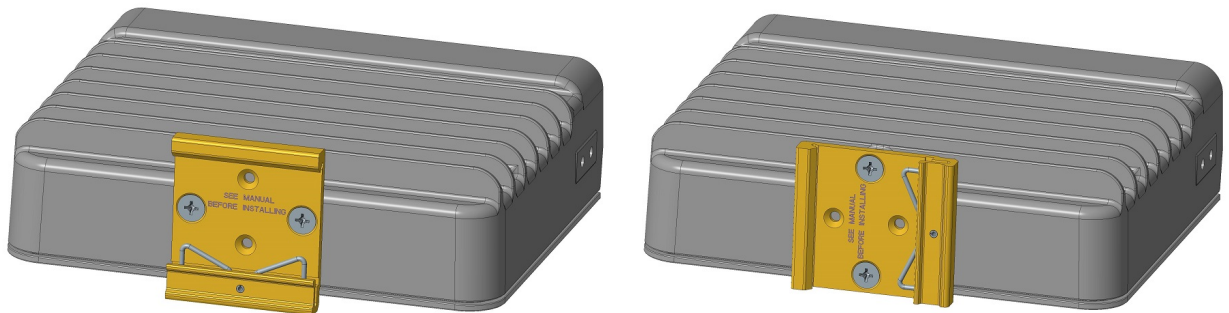

## Attaching the Bracket onto the DIN Rail

To attach the IW9165E with the bracket to a DIN rail, follow these steps.

- Step 1** Position the access point so that the lower edge and spring of the DIN clip, located within the bottom of the DIN rail bracket, engages with the bottom section of the DIN rail.

Attaching the Bracket onto the DIN Rail

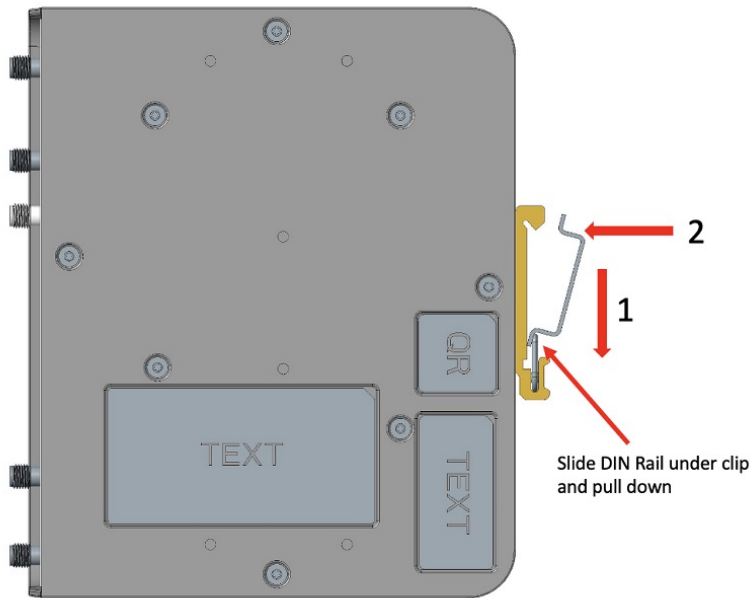

**Step 2** Push up on the AP so that the spring of the DIN clip compresses against the lower section of DIN rail, and then rotate the AP so that the top hook of the DIN clip clamps to the top section of DIN rail.

Figure 14: Bracket Attached to the DIN Rail

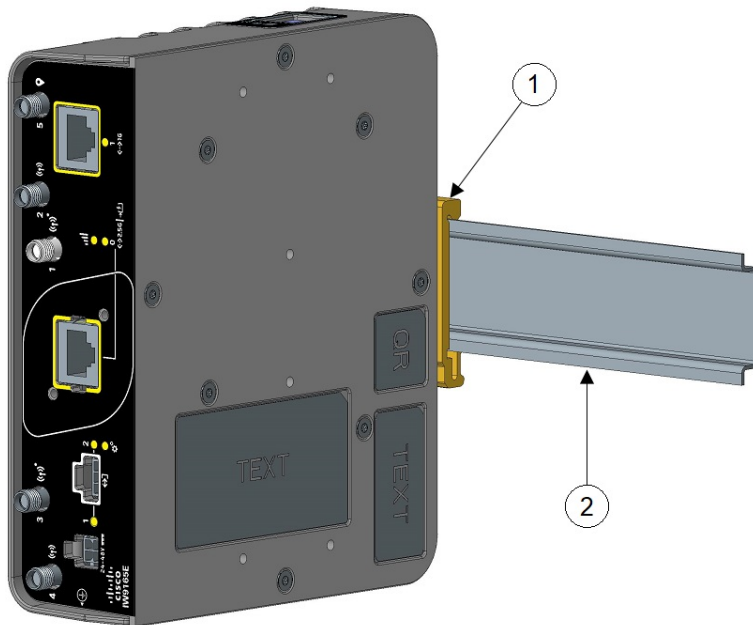

1	DIN rail bracket	2	DIN rail
---	------------------	---	----------

**Note** The procedure to attach the unit to the rail is the same with both orientations.

**Note** To remove the router from the DIN Rail, simply reverse the procedure.

## Grounding the Access Point

In all installations, after mounting the access point, you must properly ground the unit before connecting power cables.



**Warning** This equipment must be grounded. Never defeat the ground conductor or operate the equipment in the absence of a suitably installed ground conductor. Contact the appropriate electrical inspection authority or an electrician if you are uncertain that suitable grounding is available. Statement 1024



**Warning** Installation of the equipment must comply with local and national electrical codes. Statement 1074

The access point is shipped with a grounding kit.

*Figure 15: Access Point Grounding Kit Contents*



1	Grounding lug	2	6-32 screws x 2
---	---------------	---	-----------------



**Note** The grounding kit also includes the oxide inhibitor, which is contained in a tube.

To ground the access point:

**Step 1** Use a crimping tool to crimp a 6-AWG ground wire (not included in the grounding kit) to the ground lug.

## Grounding the Access Point

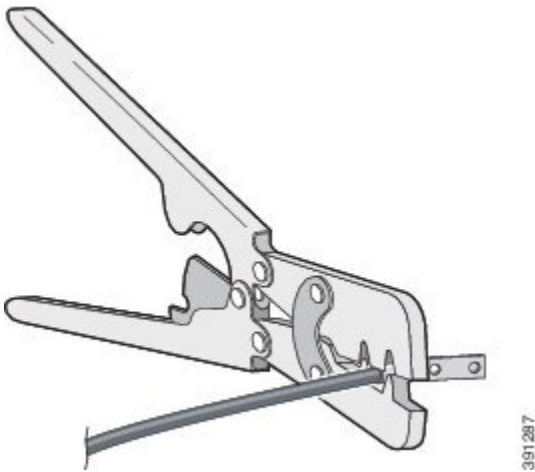

**Step 2** Connect the supplied ground lug to the access point ground connection point using the supplied screws. Apply supplied oxide inhibitor between the ground lug and the access point ground connection.

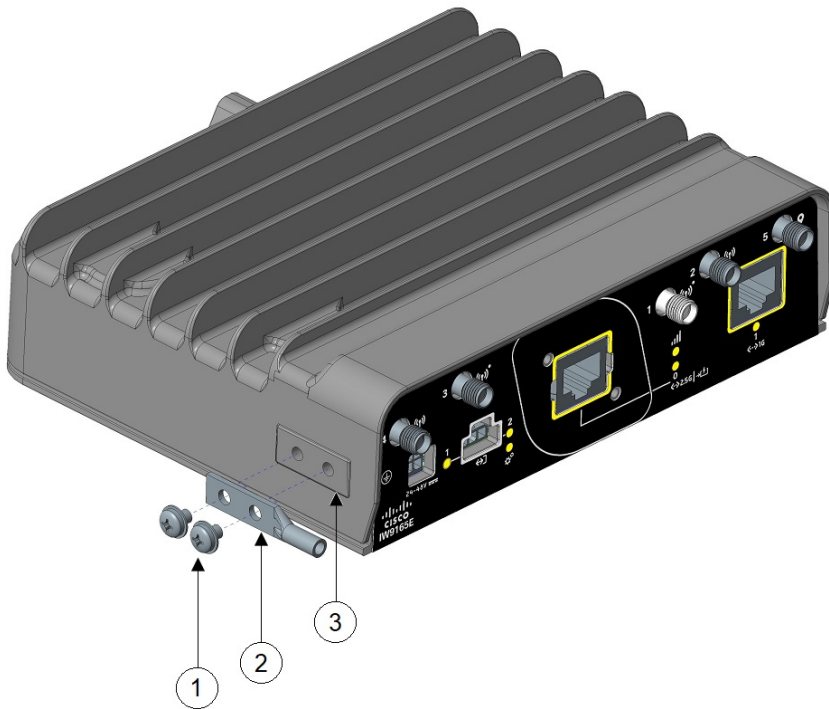

1	6-32 screws	2	Grounding lug
3	AP ground connection point		

**Step 3** Tighten the screws to 12-15 inch-lbs of torque.



- Step 4** If necessary, strip the other end of the ground wire and connect it to a reliable earth ground such as a grounding rod or appropriate ground point on a grounded pole. Length of the ground cable should not exceed 1 meter, and 0.5 meter is preferred. Use supplied oxide inhibitor on the grounded interface.

## Powering the Access Point

The AP supports these power sources:

- DC power – 24–48 VDC
- Power-over-Ethernet (PoE)

The AP can be powered via the PoE input from an inline power injector or a suitably powered switch port. Depending on the configuration and regulatory domain, the required power for full operation is 802.3bt or UPOE.

For more information, see [Power Sources, on page 6](#).

## Power Feature Matrix

The following table provides the AP power feature matrix.

**Table 8: Cisco Catalyst IW9165E Feature Matrix**

Power Input	5G Radio	5G/6G Radio	GNSS	mGig Eth	RJ45 1G
24-48V	2x2	2x2	Yes	max 2.5G	Yes
802.3at	2x2	2x2	Yes	max 2.5G	Yes
802.3af	1x1	1x1	Yes	max 1G	No

## Connecting a Power Injector

The AP supports the following power injector:

**Table 9: Supporting Power Injectors**

Power Source	Description
IW-PWRINJ-60RGDMG=	60W rated outdoor power injector, 5GE

The power injector provides DC voltage to the AP over the Ethernet cable and supports a total end-to-end Ethernet cable length of 100 m (328 ft) from the switch to the AP.

When an optional power injector powers your AP, follow these steps to complete the installation:

- Step 1** Before applying PoE to the AP, ensure that the AP is grounded (see [Grounding the Access Point, on page 23](#)).
- Step 2** Connect a CAT5e or better Ethernet cable from your wired LAN network to the power injector.

**Note** The installer is responsible for ensuring that powering the AP from this type of power injector is allowed by local and/or national safety and telecommunications equipment standards.

- Step 3** Ensure that the antennas are connected, and that ground is attached to the AP before you apply power to the AP.
- Step 4** Connect a shielded outdoor-rated Ethernet (CAT5e or better) cable between the power injector and the AP's PoE-in connector.
- Step 5** Connect the Ethernet cable to the AP PoE-In port.

## Connecting a DC Power Cable to the Access Point

Follow these steps to connect a DC power cable to the access point:

- Step 1** Before connecting DC power to the access point, ensure that the ground is connected to the access point (see [Grounding the Access Point, on page 23](#)).
- Step 2** Plug the 4-Pin Micro-Fit connector cable into the DC connector in the chassis as shown in the following figure.

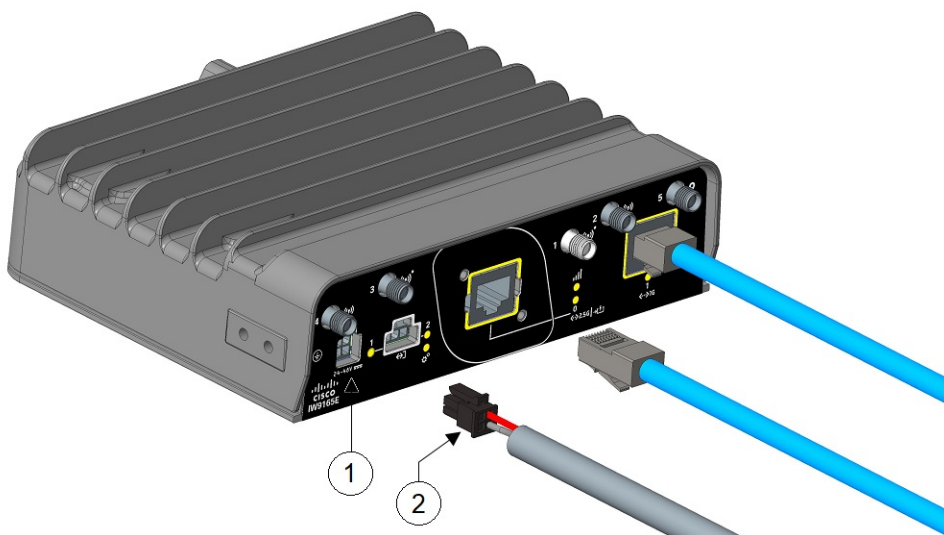

1	DC Connector	2	4-pin Micro-Fit DC connector
---	--------------	---	------------------------------

**Note** For the 4-Pin Micro-Fit connector pinouts, see [4-Pin Micro-Fit Connector for DC Power, on page 5](#).

- Step 3** Ensure that the antennas are connected to the access point before you apply power to the access point.

## Connecting an Ethernet Cable to the Access Point

Connect an Ethernet cable to the access point by using a cable gland or an M12-RJ45 adapter.

## Connecting an Ethernet Cable to the Access Point

Follow these steps to connect an Ethernet cable to the RJ-45 port:

- Step 1** Disconnect power to the power injector, and ensure all power sources to the access point are turned off.
- Step 2** Insert the RJ-45 cable connector into the Ethernet port opening on the access point as shown in the following figure:

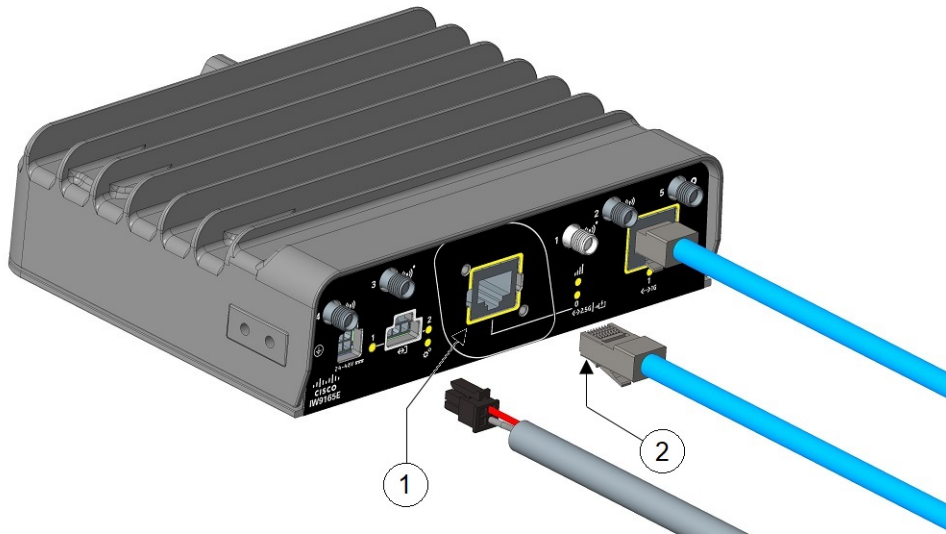

1	RJ-45 port	2	RJ-45 cable
---	------------	---	-------------

- Step 3** Ensure that the antennas are connected to the access point before you apply power to the access point.

## Connecting to the RJ-45 Port Using M12 Adapter

Follow these steps to connect to the RJ-45 port using M12 adapter:

- Step 1** Ensure the O-rings are on the M12 adapter and spacer.

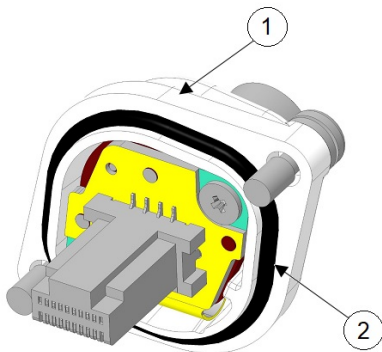

Connecting to the RJ-45 Port Using M12 Adapter

1	M12 adapter	2	O-ring
---	-------------	---	--------

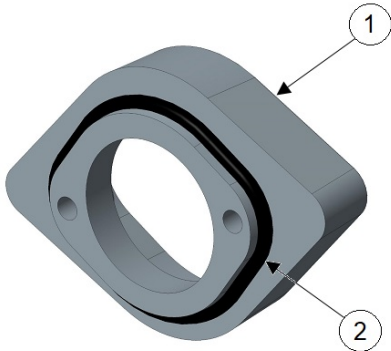

1	Spacer	2	O-ring
---	--------	---	--------

**Step 2** Attach the spacer to the chassis with the screws provided (4 in the following figure). Use 5-7 in-lbs. of torque to screw the spacer onto the access point.

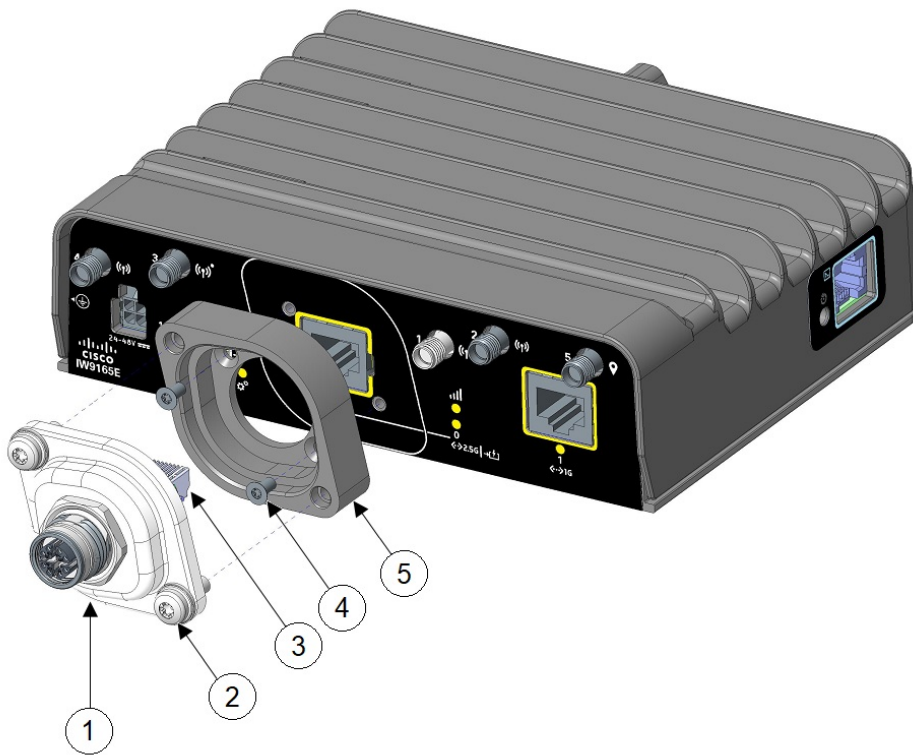

1	M12-RJ45 adapter	2	Captive screws
3	RJ45 plug	4	M3 screws

5	Spacer		
---	--------	--	--

**Step 3** Align the RJ45 plug with the RJ-45 connector in the chassis, and plug the M12 adapter into the chassis.

**Step 4** Tighten the M12 adapter captive screws into the chassis (2 in the following figure). Use 15-20 in-lbs. of torque to screw the M12 adapter onto the spacer and the chassis.

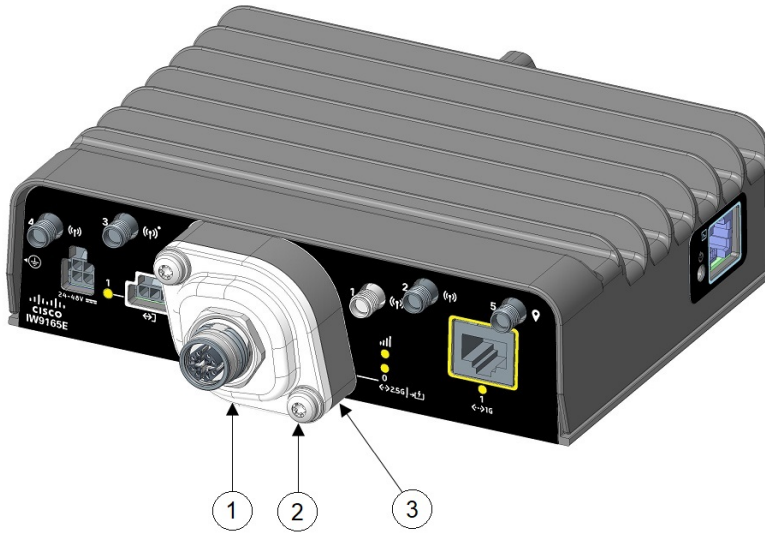

1	M12-RJ45 adapter	2	Captive screws
3	Spacer		





## CHAPTER 4

# Troubleshooting

---

- [Using the Reset Button, on page 31](#)
- [Checking the Access Point LEDs, on page 31](#)

## Using the Reset Button

Using the **Reset** button (see [Connectors and Ports, on page 2](#)), you can reset the AP to factory default or clear the AP's internal storage.

To reset the AP to the default factory-shipped configuration, perform the following steps:

- 
- Step 1** Press, and continue to press the **Reset** button on the access point during the AP boot cycle.
- Step 2** The AP status LED will turn red once the timer has started. Continue to hold the **Reset** button for more than 20 seconds, but less than 60 seconds. The following will happen:
- The AP status LED changes to solid red.
  - All the files in the AP storage directory are cleared.
  - A full factory reset is triggered.
  - The FIPS mode flag is also cleared during the full factory reset of the AP. If the FIPS flag is set, the console access is disabled.

**Note** If you keep the **Reset** button pressed for more than 60 seconds, the button is assumed as being faulty and no changes are made.

---

## Checking the Access Point LEDs

There are two LEDs located at the AP front panel, a system status LED and an RSSI LED, as shown in [Connectors and Ports, on page 2](#).



**Note** Regarding LED status colors, it is expected that there will be small variations in color intensity and hue from unit to unit. This is within the normal range of the LED manufacturer’s specifications and is not a defect. However, the intensity of the LED can be changed through the controller.

**System Status LED**

The system status LED indicates various conditions and are described in the following table.

*Table 10: System Status LED Signals*

LED Message Type	Color	Meaning
<b>Cisco URWB Mode</b>		
Limbo (Provisioning) mode: Fallback	Flashing (short blips) Blue	In the state of requesting IP address from DHCP server.
Limbo (Provisioning) mode: DHCP	Solid Blue	This status indicates that the IP address is retrieved from DHCP server.
<b>WGB Mode</b>		
Association status	Blinking Red	This status indicates no wireless client is associated with it.
	Solid Green	Normal operating condition with at least one wireless client associated with the unit.

**RSSI LED**

The RSSI LED indicates the SNR/RSSI strength as described in the following table.

*Table 11: RSSI LED Signals*

LED Status	RSSI/SNR Status
<b>Cisco URWB Mode</b>	
Solid Green	Excellent (SNR >= 25 dB)
Blinking Green	Good (15 <= SNR < 25 dB)
Solid Yellow	Bad (10 <= SNR < 15 dB)
Blinking Yellow	Worse (SNR < 10 dB)
<b>WGB Mode</b>	
Solid Green	Excellent (RSSI >= -71dBm)
Blinking Green	Good (-81 <= RSSI < -70 dBm)



LED Status	RSSI/SNR Status
Solid Yellow	Bad ( $-94 \leq \text{RSSI} < -81$ dBm)
Off	Worse ( $\text{RSSI} < -94$ dBm) <b>Note</b> When the RSSI LED is off, use system status LED to check WGB states.





## CHAPTER 5

# Safety Guidelines and Warnings

- [Safety Instructions, on page 35](#)
- [FCC Safety Compliance Statement, on page 36](#)
- [Safety Precautions, on page 36](#)
- [Safety Precautions when Installing Antennas, on page 37](#)
- [Avoiding Damage to Radios in a Testing Environment, on page 37](#)
- [Performing Site Surveys, on page 38](#)

## Safety Instructions

The translated warnings are available in the Translated Safety Warnings for Cisco Catalyst Access Points, which is available on Cisco.com.



---

**Warning** **IMPORTANT SAFETY INSTRUCTION**This warning symbol means danger. You are in a situation that could cause bodily injury. Before you work on any equipment, be aware of the hazards involved with electrical circuitry and be familiar with standard practices for preventing accidents. Use the statement number provided at the end of each warning to locate its translation in the translated safety warnings that accompanied this device.**SAVE THESE INSTRUCTIONS** Statement 1071

---



---

**Warning** **This product relies on the building's installation for short-circuit (overcurrent) protection. Ensure that the protective device is rated not greater than 20A.** Statement 1005

---



---

**Warning** **Installation of the equipment must comply with local and national electrical codes.** Statement 1074

---



---

**Warning** **Ultimate disposal of this product should be handled according to all national laws and regulations.** Statement 9001

---



---

**Caution** Ensure to connect the power cord of the power adapter to a socket outlet with an earthing connection.

---

## FCC Safety Compliance Statement

The FCC, with its action in ET Docket 96-8, has adopted a safety standard for human exposure to RF electromagnetic energy emitted by FCC-certified equipment. When used with approved Cisco antennas, Cisco Catalyst products meet the uncontrolled environmental limits found in OET-65 and ANSI C95.1, 1991. Proper operation of this radio device according to the instructions in this publication results in user exposure substantially below the FCC recommended limits.

## Safety Precautions

For safety and to achieve a good installation, please read and follow these safety precautions:

- Select your installation site with safety as well as performance in mind. Remember: electric power lines and phone lines look alike. For safety, assume that any overhead line can kill.
- Call your electric power company. Tell them your plans, and ask them to come to look at your proposed installation
- Plan your installation carefully and thoroughly before you begin. Successful raising of a mast or tower is mostly a matter of coordination. Each person should be assigned to a specific task and know what to do and when to do it. One person should be in charge of the operation to issue instructions and watch for signs of trouble.
- When installing the AP or its antennas, remember:
  - Do not use a metal ladder.
  - Do not work on a wet or windy day.
  - Do dress properly—shoes with rubber soles and heels, rubber gloves, long-sleeved shirt or jacket.
- Use a rope to lift the AP. If the assembly starts to drop, get away from it and let it fall.
- If any part of the antenna system comes in contact with a power line, do not touch it or remove it yourself. Call your local power company. They will remove it safely.

If an accident should occur, call for qualified emergency help immediately.

# Safety Precautions when Installing Antennas



**Danger** Do not locate the antenna near overhead power lines or other electric light or power circuits, or where it can come into contact with such circuits. When installing the antenna, take extreme care not to come into contact with such circuits, as they may cause serious injury or death. For proper installation and grounding of the antenna, please refer to national and local codes (e.g. U.S.: NFPA 70, National Electrical Code, Article 810, Canada: Canadian Electrical Code, Section 54). Statement 280

- Before you install an antenna, contact your Cisco account representative to explain which mounting method to use for the size and type of antenna that you are about to install
- Select your installation site with safety, as well as performance, in mind. Remember that electric power lines and phone lines look alike. For your safety, assume that any overhead line can kill you.
- Contact your electric power company. Tell them your plans and ask them to come look at your proposed installation.
- Plan your installation carefully and completely before you begin. Each person involved in an installation should be assigned to a specific task and should know what to do and when to do it. One person should be in charge of the operation to issue instructions and watch for signs of trouble.
- When installing your antenna, follow these guidelines:
  - Do not use a metal ladder
  - Do not work on a wet or windy day
  - Do dress properly—wear shoes with rubber soles and heels, rubber gloves, and a long-sleeved shirt or jacket
- If the assembly starts to drop, move away from it and let it fall. Because the antenna, mast, cable, and metal guy wires are all excellent conductors of electrical current, even the slightest touch of any of these parts to a power line completes an electrical path through the antenna and the installer.
- If any part of the antenna system should come in contact with a power line, do not touch it or try to remove it yourself. Call your local power company to have it removed safely.
- If an accident should occur with the power lines, call for qualified emergency help immediately.

## Avoiding Damage to Radios in a Testing Environment

The radios on outdoor units (bridges) have higher transmit power levels than radios on indoor units (APs). When you test high-power radios in a link, you must avoid exceeding the receiver's maximum receive input level. At levels above the normal operating range, packet error rate (PER) performance is degraded. At even higher levels, the receiver can be permanently damaged. To avoid receiver damage and PER degradation, you can use one of the following techniques:

- Separate the omnidirectional antennas by at least 2 ft (0.6 m) to avoid receiver damage or by at least 25 ft (7.6 m) to avoid PER degradation.



---

**Note** These distances assume free space path loss and are conservative estimates. Required separation distances for damage and performance degradation levels in actual deployments are less if conditions are not non-line-of-sight.

---

- Reduce the configured transmit power to the minimum level.
- Use directional antennas, and keep them away from each other.
- Cable the radios together using a combination of attenuators, combiners, or splitters to achieve a total attenuation of at least 60 dB.

For a radiated testbed, the following equation describes the relationships among transmit power, antenna gain, attenuation, and receiver sensitivity:

$$\text{txpwr} + \text{tx gain} + \text{rx gain} - [\text{attenuation due to antenna spacing}] < \text{max rx input level}$$

Where:

txpwr = Radio transmit power level

tx gain = transmitter antenna gain

rx gain = receiver antenna gain

For a conducted test bed, the following equation describes the relationships among transmit power, antenna gain, and receiver sensitivity:

$$\text{txpwr} - [\text{attenuation due to coaxial components}] < \text{max rx input level}$$



---

**Caution** Under no circumstances should you connect the antenna port from one AP to the antenna port of another AP without using an RF attenuator. If you connect antenna ports, you must not exceed the maximum survivable receive level of 0 dBm. Never exceed 0 dBm, or damage to the AP can occur. Using attenuators, combiners, and splitters having a total of at least 60 dB of attenuation ensures that the receiver is not damaged and that PER performance is not degraded.

---

## Performing Site Surveys

Every network application is a unique installation. Before installing multiple APs, you should perform a site survey to determine the optimum use of networking components and maximize range, coverage, and network performance.

Site surveys reveal problems that can be resolved before the network is operational. Because 802.11a/b/g/n/ac/ax operates in an unlicensed spectrum, there may be sources of interference from other 802.11a wireless devices (especially in multi-tenant buildings) that could degrade your 802.11 signals. A site survey can determine if such interference exists at the time of deployment.

Consider the following operating and environmental conditions when performing a site survey:

- Data rates: Sensitivity and range are inversely proportional to data bit rates. The maximum radio range is achieved at the lowest workable data rate. A decrease in receiver sensitivity occurs as the radio data increases.

- **Antenna type and placement:** Proper antenna configuration is a critical factor in maximizing radio range. As a general rule, range increases in proportion to antenna height. However, do not place the antenna higher than necessary because the extra height also increases potential interference from other unlicensed radio systems and decreases the wireless coverage from the ground.
- **Physical environment:** Clear or open areas provide better radio range than closed or filled areas.
- **Obstructions:** Physical obstructions such as buildings, trees, or hills can hinder the performance of wireless devices. Avoid locating the devices in a location where there is an obstruction between the sending and receiving antennas.
- How far is your wireless link?
- Has a previous site survey been conducted?
- Do you have a clear Fresnel zone between the APs or radio line of sight?
- What is the minimum acceptable data rate within the link?
- Do you have the correct antenna (if more than one antenna is being offered?)
- Do you have the proper permits, if required?
- Are you following the proper safety procedures and practices?
- Have you configured the APs before you go onsite? It is always easier to resolve configurations or device problems first.
- Do you have the proper tools and equipment to complete your survey?







## CHAPTER 6

# Declarations of Conformity and Regulatory Information

---

- [Manufacturers Federal Communications Commission Declaration of Conformity Statement, on page 41](#)
- [Operation of Cisco Catalyst Access Points in México, on page 42](#)
- [VCCI Statement for Japan, on page 42](#)
- [Compliance Statement for Canada, on page 44](#)
- [European Community, Switzerland, Norway, Iceland, and Liechtenstein, on page 45](#)
- [United Kingdom Compliance, on page 45](#)
- [Declaration of Conformity for RF Exposure, on page 46](#)
- [Declaration of Conformity Statements, on page 48](#)

## Manufacturers Federal Communications Commission Declaration of Conformity Statement



Access Point Models	Certification Number
IW9165E-B	LDKIW9165E

Manufacturer:

Cisco Systems, Inc.

170 West Tasman Drive

San Jose, CA 95134-1706

USA

This device complies with Part 15 rules. Operation is subject to the following two conditions:

1. This device may not cause harmful interference,
2. This device must accept any interference received, including interference that may cause undesired operation.

#### **Federal Communications Commission Interference Statement**

This equipment has been tested and found to comply with the limits for a Class A digital device, pursuant to part 15 of the FCC Rules. These limits are designed to provide reasonable protection against harmful interference when the equipment is operated in a commercial environment. This equipment generates, uses, and can radiate radio frequency energy and, if not installed and used in accordance with the instruction manual, may cause harmful interference to radio communications. Operation of this equipment in a residential area is likely to cause harmful interference in which case the user will be required to correct the interference at his own expense.



---

#### **Caution**

The Part 15 radio device operates on a non-interference basis with other devices operating at this frequency when using the integrated antennas. Any changes or modification to the product not expressly approved by Cisco could void the user's authority to operate this device.

---

## Operation of Cisco Catalyst Access Points in México

Declaración para México

La operación de este equipo está sujeta a las siguientes dos condiciones: (1) es posible que este equipo o dispositivo no cause interferencia perjudicial y (2) este equipo o dispositivo debe aceptar cualquier interferencia, incluyendo la que pueda causar su operación no deseada.

## VCCI Statement for Japan

### Statement 191—Voluntary Control Council for Interference (VCCI) Class A Warning for Japan



---

#### **Warning**

This is a Class A product based on the standard of the VCCI Council. If this equipment is used in a domestic environment, radio interference may occur, in which case, you may be required to take corrective actions.

---

## ステートメント 191—日本向け VCCI クラス A に関する警告



**警告** この装置は、クラス A 機器です。この装置を住宅環境で使用すると電波妨害を引き起こすことがあります。この場合には使用者が適切な対策を講ずるよう要求されることがあります。

VCCI-A

## Guidelines for Operating Cisco Catalyst Access Points in Japan

This section provides guidelines for avoiding interference when operating Cisco Catalyst access points in Japan. These guidelines are provided in both Japanese and English.

この機器の使用周波数帯では、電子レンジ等の産業・科学・医療用機器のほか工場の製造ライン等で使用されている移動体識別用の構内無線局（免許を要する無線局）及び特定小電力無線局（免許を要しない無線局）が運用されています。

1. この機器を使用する前に、近くで移動体識別用の構内無線局及び特定小電力無線局が運用されていないことを確認して下さい。
2. 万一、この機器から移動体識別用の構内無線局に対して電波干渉の事例が発生した場合には、速やかに使用周波数を変更するか又は電波の発射を停止した上、下記連絡先にご連絡頂き、混信回避のための処置等（例えば、ノークーティションの設置など）についてご相談して下さい。
3. その他、この機器から移動体識別用の特定、小電力無線局に対して電波干渉の事例が発生した場合など何かお困りのことが起きたときは、次の連絡先へお問い合わせ下さい。

連絡先: 03-6434-6500

### English Translation

This equipment operates in the same frequency bandwidth as industrial, scientific, and medical devices such as microwave ovens and mobile object identification (RF-ID) systems (licensed premises radio stations and unlicensed specified low-power radio stations) used in factory production lines.

1. Before using this equipment, make sure that no premises radio stations or specified low-power radio stations of RF-ID are used in the vicinity.
2. If this equipment causes RF interference to a premises radio station of RF-ID, promptly change the frequency or stop using the device; contact the number below and ask for recommendations on avoiding radio interference, such as setting partitions.
3. If this equipment causes RF interference to a specified low-power radio station of RF-ID, contact the number below.

Contact Number: 03-6434-6500

## Compliance Statement for Canada

This device complies with Industry Canada licence-exempt RSS standard(s). Operation is subject to the following two conditions: (1) this device may not cause interference, and (2) this device must accept any interference, including interference that may cause undesired operation of the device. Le présent appareil est conforme aux CNR d'Industrie Canada applicables aux appareils radio exempts de licence. L'exploitation est autorisée aux deux conditions suivantes : (1) l'appareil ne doit pas produire de brouillage, et (2) l'utilisateur de l'appareil doit accepter tout brouillage radioélectrique subi, même si le brouillage est susceptible d'en compromettre le fonctionnement.

Under Industry Canada regulations, this radio transmitter may only operate using an antenna of a type and maximum (or lesser) gain approved for the transmitter by Industry Canada. To reduce potential radio interference to other users, the antenna type and its gain should be so chosen that the equivalent isotropically radiated power (e.i.r.p.) is not more than that necessary for successful communication. Conformément à la réglementation d'Industrie Canada, le présent émetteur radio peut fonctionner avec une antenne d'un type et d'un gain maximal (ou inférieur) approuvé pour l'émetteur par Industrie Canada. Dans le but de réduire les risques de brouillage radioélectrique à l'intention des autres utilisateurs, il faut choisir le type d'antenne et son gain de sorte que la puissance isotrope rayonnée équivalente (p.i.r.e.) ne dépasse pas l'intensité nécessaire à l'établissement d'une communication satisfaisante.

This radio transmitter has been approved by Industry Canada to operate with the antenna types listed below with the maximum permissible gain and required antenna impedance for each antenna type indicated. Antenna types not included in this list, having a gain greater than the maximum gain indicated for that type, are strictly prohibited for use with this device. Le présent émetteur radio a été approuvé par Industrie Canada pour fonctionner avec les types d'antenne énumérés ci-dessous et ayant un gain admissible maximal et l'impédance requise pour chaque type d'antenne. Les types d'antenne non inclus dans cette liste, ou dont le gain est supérieur au gain maximal indiqué, sont strictement interdits pour l'exploitation de l'émetteur.

Operation in the band 5150-5250 MHz is only for indoor use to reduce the potential for harmful interference to co-channel mobile satellite systems. La bande 5 150-5 250 MHz est réservés uniquement pour une utilisation à l'intérieur afin de réduire les risques de brouillage préjudiciable aux systèmes de satellites mobiles utilisant les mêmes canaux.

Users are advised that high-power radars are allocated as primary users (i.e. priority users) of the bands 5250-5350 MHz and 5650-5850 MHz and that these radars could cause interference and/or damage to LE-LAN devices. Les utilisateurs êtes avisés que les utilisateurs de radars de haute puissance sont désignés utilisateurs principaux (c.-à-d., qu'ils ont la priorité) pour les bandes 5 250-5 350 MHz et 5 650-5 850 MHz et que ces radars pourraient causer du brouillage et/ou des dommages aux dispositifs LAN-EL.

## Industry Canada

Access Point Models	Certification Number
IW9165E-A	IC:2461A-IW9165E

### IC Radiation Exposure Statement

This equipment complies with IC RSS-102 radiation exposure limits set forth for an uncontrolled environment. This equipment should be installed and operated with minimum distance 20 cm between the radiator and your body.

Cet équipement est conforme aux limites d'exposition aux rayonnements IC établies pour un environnement non contrôlé. Cet équipement doit être installé et utilisé avec un minimum de 20 cm de distance entre la source de rayonnement et votre corps.

## European Community, Switzerland, Norway, Iceland, and Liechtenstein

### Access Point Models:

IW9165E-E

The product carries the CE Mark:



The device is restricted to indoor use only when operating between 5150 MHz and 5350 MHz, 5925 MHz and 6425 MHz frequency range.

This equipment complies with EU radiation exposure limits set forth for an uncontrolled environment. This equipment should be installed and operated with minimum distance 20 cm (7.87 inches) between the radiator & your body.



**Note** This equipment is intended to be used in all EU and EFTA countries. Outdoor use may be restricted to certain frequencies and/or may require a license for operation. For more details, contact Cisco Corporate Compliance.

The frequency and the maximum transmitted power in EU are listed below:

2402-2480MHz (LE): 9.92 dBm

5180-5240MHz: 22.96 dBm

5260-5320MHz: 22.98 dBm

5500-5700: 29.99 dBm

	AT	BE	BG	HR	CY	CZ	DK
	EE	FI	FR	DE	EL	HU	IE
	IT	LV	LT	LU	MT	NL	PL
	PT	RO	SK	SI	ES	SE	UK(NI)

Norway(NO), Iceland(IS), Lichtenstein(LI), Turkey(TR), Switzerland(CH)

## United Kingdom Compliance

### Access Point Models:

IW9165E-ROW

The device is restricted to indoor use only when operating between 5150 MHz and 5350 MHz, 5925 MHz and 6425 MHz frequency range. This equipment should be installed and operated with minimum distance 20 cm (7.87 inches) between the radiator & your body.

The frequency and the maximum transmitted power in UK are listed below:

2402-2480MHz (LE): 9.92 dBm

5180-5240MHz: 22.96 dBm

5260-5320MHz: 22.98 dBm

5500-5700: 29.99 dBm

## Declaration of Conformity for RF Exposure

This section contains information on compliance with guidelines related to RF exposure.

### Generic Discussion on RF Exposure

The Cisco products are designed to comply with the following national and international standards on Human Exposure to Radio Frequencies:

- US 47 Code of Federal Regulations Part 2 Subpart J
- American National Standards Institute (ANSI) / Institute of Electrical and Electronic Engineers / IEEE C 95.3
- International Commission on Non Ionizing Radiation Protection (ICNIRP) 98
- Ministry of Health (Canada) Safety Code 6. Limits on Human Exposure to Radio Frequency Fields in the range from 3kHz to 300 GHz
- Australia Radiation Protection Standard

To ensure compliance with various national and international Electromagnetic Field (EMF) standards, the system should only be operated with Cisco approved antennas and accessories.

### This Device Meets International Guidelines for Exposure to Radio Waves

The IW9165E device includes a radio transmitter and receiver. It is designed not to exceed the limits for exposure to radio waves (radio frequency electromagnetic fields) recommended by international guidelines. The guidelines were developed by an independent scientific organization (ICNIRP) and include a substantial safety margin designed to ensure the safety of all persons, regardless of age and health.

As such the systems are designed to be operated as to avoid contact with the antennas by the end user. It is recommended to set the system in a location where the antennas can remain at least a minimum distance as specified from the user in accordance to the regulatory guidelines which are designed to reduce the overall exposure of the user or operator.

RF Exposure Distance
20 cm

The World Health Organization has stated that present scientific information does not indicate the need for any special precautions for the use of wireless devices. They recommend that if you are interested in further reducing your exposure then you can easily do so by reorienting antennas away from the user or placing the antennas at a greater separation distance than recommended.

## This Device Meets FCC Guidelines for Exposure to Radio Waves

The IW9165E device includes a radio transmitter and receiver. It is designed not to exceed the limits for exposure to radio waves (radio frequency electromagnetic fields) as referenced in FCC Part 2.1091. The guidelines are based on IEEE ANSI C 95.3 and KDB 447498 and include a substantial safety margin designed to ensure the safety of all persons, regardless of age and health.

As such the systems are designed to be operated as to avoid contact with the antennas by the end user. It is recommended to set the system in a location where the antennas can remain at least a minimum distance as specified from the user in accordance to the regulatory guidelines which are designed to reduce the overall exposure of the user or operator.

The device has been tested and found compliant with the applicable regulations as part of the radio certification process.

RF Exposure Distance
40 cm

The US Food and Drug Administration has stated that present scientific information does not indicate the need for any special precautions for the use of wireless devices. The FCC recommends that if you are interested in further reducing your exposure then you can easily do so by reorienting antennas away from the user or placing the antennas at a greater separation distance than recommended or lowering the transmitter power output.

## This Device Meets the Industry Canada Guidelines for Exposure to Radio Waves

The IW9165E device includes a radio transmitter and receiver. It is designed not to exceed the limits for exposure to radio waves (radio frequency electromagnetic fields) as referenced in Health Canada Safety Code 6. The guidelines include a substantial safety margin designed into the limit to ensure the safety of all persons, regardless of age and health.

As such the systems are designed to be operated as to avoid contact with the antennas by the end user. It is recommended to set the system in a location where the antennas can remain at least a minimum distance as specified from the user in accordance to the regulatory guidelines which are designed to reduce the overall exposure of the user or operator.

RF Exposure Distance
20 cm

Health Canada states that present scientific information does not indicate the need for any special precautions for the use of wireless devices. They recommend that if you are interested in further reducing your exposure you can easily do so by reorienting antennas away from the user, placing the antennas at a greater separation distance than recommended, or lowering the transmitter power output.

## Cet appareil est conforme aux directives internationales en matière d'exposition aux fréquences radioélectriques

Cet appareil de la gamme IW9165E comprend un émetteur-récepteur radio. Il a été conçu de manière à respecter les limites en matière d'exposition aux fréquences radioélectriques (champs électromagnétiques de fréquence radio), recommandées dans le code de sécurité 6 de Santé Canada. Ces directives intègrent une marge de sécurité importante destinée à assurer la sécurité de tous, indépendamment de l'âge et de la santé.

Par conséquent, les systèmes sont conçus pour être exploités en évitant que l'utilisateur n'entre en contact avec les antennes. Il est recommandé de poser le système là où les antennes sont à une distance minimale telle que précisée par l'utilisateur conformément aux directives réglementaires qui sont conçues pour réduire l'exposition générale de l'utilisateur ou de l'opérateur.

Distance d'exposition RF
20 cm

Santé Canada affirme que la littérature scientifique actuelle n'indique pas qu'il faille prendre des précautions particulières lors de l'utilisation d'un appareil sans fil. Si vous voulez réduire votre exposition encore davantage, selon l'agence, vous pouvez facilement le faire en réorientant les antennes afin qu'elles soient dirigées à l'écart de l'utilisateur, en les plaçant à une distance d'éloignement supérieure à celle recommandée ou en réduisant la puissance de sortie de l'émetteur.

## Additional Information on RF Exposure

You can find additional information on the subject at the following links:

- Cisco Systems Spread Spectrum Radios and RF Safety white paper at this URL: [http://www.cisco.com/warp/public/cc/pd/witc/ao340ap/prodlit/rfhr\\_wi.htm](http://www.cisco.com/warp/public/cc/pd/witc/ao340ap/prodlit/rfhr_wi.htm)
- FCC Bulletin 56: Questions and Answers about Biological Effects and Potential Hazards of Radio Frequency Electromagnetic Fields
- FCC Bulletin 65: Evaluating Compliance with the FCC guidelines for Human Exposure to Radio Frequency Electromagnetic Fields

You can obtain additional information from the following organizations:

- World Health Organization Internal Commission on Non-Ionizing Radiation Protection at this URL: [www.who.int/emf](http://www.who.int/emf)
- United Kingdom, National Radiological Protection Board at this URL: [www.nrpb.org.uk](http://www.nrpb.org.uk)
- Cellular Telecommunications Association at this URL: [www.wow-com.com](http://www.wow-com.com)
- The Mobile Manufacturers Forum at this URL: [www.mmfa.org](http://www.mmfa.org)

## Declaration of Conformity Statements

All the Declaration of Conformity statements related to this product can be found at the following location: <https://pas.cisco.com/pdtncc/#/>