



USER GUIDE

1.5.0 | January 2022 | 3725-62048-006C

Poly Studio USB Video Bar

Getting Help

For more information about installing, configuring, and administering Poly/Polycom products or services, go to Poly Online Support Center.

Poly
345 Encinal Street
Santa Cruz, California
95060

© 2021 Poly. Bluetooth is a registered trademark of Bluetooth SIG, Inc. All other trademarks are the property of their respective owners.

Contents

- Before You Begin.....3**
 - Audience, Purpose, and Required Skills.....3
 - Related Poly and Partner Resources.....3
 - Privacy Policy.....4

- Getting Started..... 5**
 - Poly Studio Overview.....5
 - Powering On and Off.....6
 - Navigating Poly Studio.....6
 - Basic Poly Studio LED Indicators.....7
 - Poly Studio Remote Control Features.....8
 - Poly Studio Privacy Shutter.....9
 - Accessibility Features..... 10

- Using Poly Studio.....12**
 - Set Poly Studio as the Default Audio and Video Device..... 12
 - Using Camera Presets..... 13
 - Tracking Modes.....13
 - Conversation Mode..... 14
 - Presenter Mode..... 14
 - Connect Poly Studio to a Bluetooth Device..... 14

- Configuring Poly Studio Using Polycom Companion..... 16**
 - Initialize the Poly Studio Device Using the Setup Wizard..... 16
 - View Poly Studio Information..... 18
 - Updating the Poly Studio Firmware.....18
 - Update the Poly Studio Firmware from Your Computer..... 18
 - Update the Poly Studio Device and the Remote Control..... 19
 - Poly Studio User Settings..... 19
 - Control the Device Camera..... 19
 - Configure Advanced Camera Settings.....20
 - Pair the Poly Studio Device to a Bluetooth Device.....21
 - Configuring Audio Settings.....21
 - Poly Studio Admin Settings.....23
 - Log In to Poly Studio Admin Settings.....23
 - Change Your Password.....23
 - Configure General Settings.....23

Configuring Camera Tracking.....	24
Join a Wi-Fi Network.....	26
Delete Known Wi-Fi Networks.....	28
Configure Bluetooth Settings.....	29
Configure a Provisioning Server for the Poly Studio Device.....	29
Certificate Signing Requests.....	30
Import a Configuration File.....	33
Export a Configuration File to Your Local System.....	33
Troubleshooting.....	34
Identifying Issues Using the LED Indicators.....	34
Restart Your Poly Studio Device.....	34
Restore Default Settings.....	35
Factory Reset Poly Studio.....	35
Factory Reset Your Poly Studio Device Using Polycom Companion.....	36
Pair the Bluetooth Remote Control with Poly Studio.....	36
Troubleshoot the Remote Control.....	36
Test Your Camera Audio Input.....	37
Display Camera Information On-Screen.....	37
Download Log and Crash Files.....	37
Can't Upgrade, Reset, or Reboot Poly Studio via Polycom Companion.....	38

Before You Begin

Topics:

- [Audience, Purpose, and Required Skills](#)
- [Related Poly and Partner Resources](#)
- [Privacy Policy](#)

This guide provides overview information and references about the Poly Studio (model P009) USB video bar, an all-in-one audio-video hub.

Audience, Purpose, and Required Skills

This guide is intended for beginning users, as well as intermediate and advanced users who want to learn how to use the features available with Poly Studio.

Related Poly and Partner Resources

See the following sites for information related to this product.

- The [Poly Online Support Center](#) is the entry point to online product, service, and solution support information including Video Tutorials, Documents & Software, Knowledge Base, Community Discussions, Poly University, and additional services.
- The [Poly Document Library](#) provides support documentation for active products, services, and solutions. The documentation displays in responsive HTML5 format so that you can easily access and view installation, configuration, or administration content from any online device.
- The [Poly Community](#) provides access to the latest developer and support information. Create an account to access Poly support personnel and participate in developer and support forums. You can find the latest information on hardware, software, and partner solutions topics, share ideas, and solve problems with your colleagues.
- The [Poly Partner Network](#) is a program where resellers, distributors, solutions providers, and unified communications providers deliver high-value business solutions that meet critical customer needs, making it easy for you to communicate face-to-face using the applications and devices you use every day.
- The [Poly Services](#) help your business succeed and get the most out of your investment through the benefits of collaboration.
- [Poly Lens](#) enables better collaboration for every user in every workspace. It is designed to spotlight the health and efficiency of your spaces and devices by providing actionable insights and simplifying device management.
- With [Poly+](#) you get exclusive premium features, insights and management tools necessary to keep employee devices up, running and ready for action.

Privacy Policy

Poly products and services process customer data in a manner consistent with the [Poly Privacy Policy](#). Please direct comments or questions to privacy@poly.com

Getting Started

Topics:

- [Poly Studio Overview](#)
- [Powering On and Off](#)
- [Navigating Poly Studio](#)
- [Accessibility Features](#)

The Poly Studio USB video bar is an all-in-one video and audio hub for small rooms.

Poly Studio Overview

The Poly Studio USB video bar is a high-quality camera and speakerphone system that integrates an auto-framing camera, stereo microphones, and stereo speakers.

Poly Studio works with applications that support standard USB devices, such as Polycom RealPresence Desktop, Microsoft Skype for Business, Microsoft Teams, Zoom, and BlueJeans.

As a USB camera and speakerphone, you can use the Poly Studio USB video bar for audio or video conferencing and as a speaker for your local devices. You can also use Poly Studio as a Bluetooth device that supports audio calls and streaming music playback from a mobile device.

You can connect the Poly Studio USB video bar to either a permanently installed PC USB host in the room or to a laptop that you bring to the room. In all configurations, you primarily connect through USB, with an optional Bluetooth connection.

If you're the administrator of the Poly Studio USB video bar, download Polycom Companion for advanced setup options, such as connecting Poly Studio to your Wi-Fi network. You can manage the Poly Studio USB video bar from Poly Lens, Polycom Device Management Services for Enterprises, or Polycom RealPresence Resource Manager via Wi-Fi connectivity. See the [Poly Documentation Library](#) for more information about these products.

Highlights of the Poly Studio USB video bar include the following:

- High-fidelity stereo microphones that pick up sound within 3.66 m (12 ft), together with spatial audio to imitate life-like presence and clarity.
 - Poly Studio also supports Polycom Acoustic Fence with Beam Shaping that enables video conferencing in open workspaces by capturing only the voices within a defined zone.
 - The NoiseBlockAI feature listens for times when sound is occurring but no one is talking and automatically mutes your microphone until you speak.
- Ultra-wide 120-degree field of view that captures 4K UHD video.
- Automatic speaker-tracking technology that zooms in on the person who's talking without using a remote control or camera presets. When there's no active speaker, the group frame function automatically frames all conference participants as a group.

Note: Poly Studio supports 4K video, but the functionality depends on the software client and monitor you use. For example, if you use a USB 3.0 cable and the Windows 10 Camera app, you can get a 4K preview.

When you use a USB 2.0 cable, the 2K or 4K video resolution requires H.264 support. You can download and install the UVC 1.5 driver from the [Poly Online Support Center](#) to enable H.264 streaming.

Related Links

[Configuring Poly Studio Using Polycom Companion](#) on page 16

Powering On and Off

The Poly Studio doesn't have a power button. When you plug in the power cord, the device turns on.

Navigating Poly Studio

The Poly Studio USB video bar includes an integrated device with a camera, speakers, a microphone array, and a remote control.

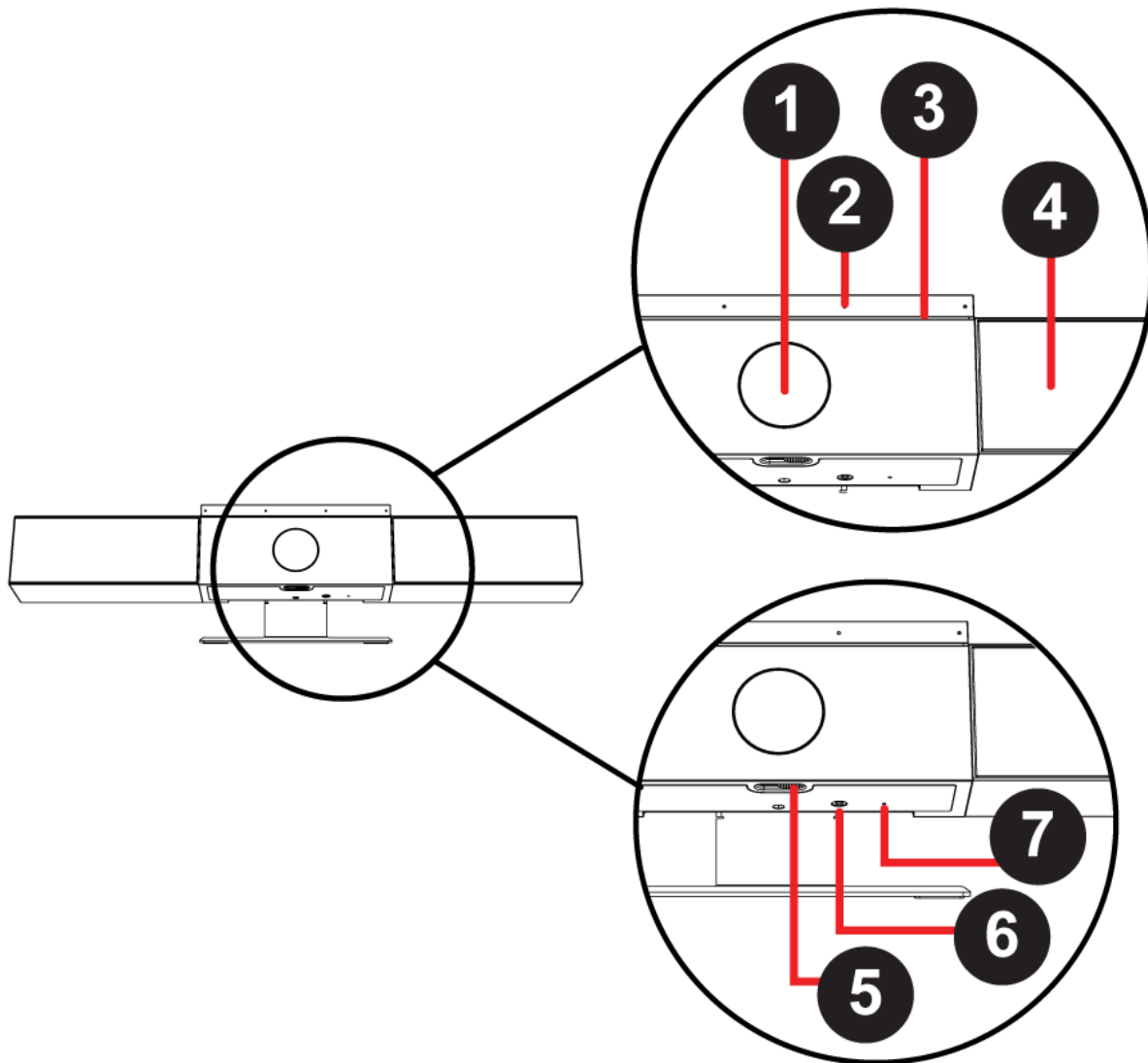

Poly Studio Feature Descriptions

Reference	Feature	Feature Description
1	Camera	Camera with a privacy shutter that enables or disables the video input as you choose
2	Microphone array	Stereo microphone that captures audio
3	LED indicators	Indicate the status and the tracked speaker
4	Speakers	Provide stereo audio output
5	Privacy shutter lever	Covers or uncovers the camera lens
6	Remote control pairing	Enables the Bluetooth remote control pairing mode
7	Reset	Factory resets the Poly Studio device or clears all saved configurations

Basic Poly Studio LED Indicators

The Poly Studio device provides an LED bar above the camera to help you understand its behaviors.

Basic Poly Studio LED Indicators and Status

Indicator	Position	Status
Chasing white	All while alternating	Boot initialization in progress
Blinking blue	Two in the middle	Bluetooth in discovery
Solid blue for three seconds	Two in the middle	Bluetooth paired
Solid amber	Two in the middle	Standing by The privacy cover is open, and the camera is in sleep mode with no active video output
Blinking green or white	All	Incoming call
Solid green or amber	Two in the middle	Outgoing call
Solid green or white	One or two (when in the middle), indicating the tracked speaker or the direction of the camera	Working The lights are green with supported applications in the following cases: <ul style="list-style-type: none"> Tracking people in group framing and speaker tracking mode Indicating the direction of the camera that you customize in pan-tilt-zoom (PTZ) mode

Indicator	Position	Status
Solid white for three seconds	Two in the middle	Saving a preset
Solid red	All	Muted microphone
Blinking red	Two in the middle	On hold

Poly Studio Remote Control Features

The Poly Studio USB video bar provides a low-energy Bluetooth remote control, which automatically pairs with the device when you turn it on for the first time.

By default, Poly Studio enables the group framing and speaker tracking function, which provides a hands-free experience except for basic buttons like volume, mute, answer, and hang-up.

The remote control sleeps if it's inactive for 30 seconds. You can press any key or move it to wake it up.

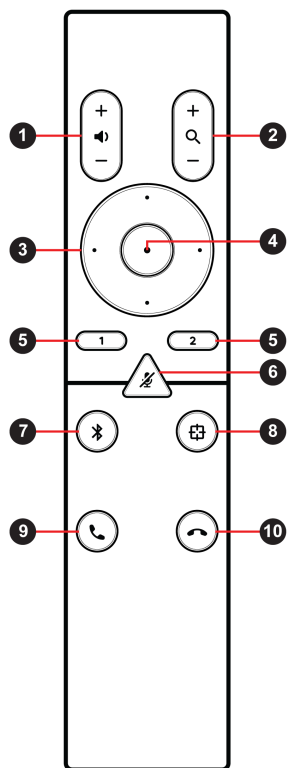

Button Icon	Button Name	Description
1	Volume Up/Down	Adjust speaker volume.
2	Zoom In/Out	Adjust camera zoom in/out when the group framing and speaker-tracking mode is off.
3	Camera Directions	Adjust the direction of camera when the group framing and speaker-tracking mode is off.

Button Icon	Button Name	Description
4	Home	Resets the camera to its original status when the tracking mode is off.
5	Preset 1/2	<ul style="list-style-type: none"> ▪ Long press to store a camera setting. ▪ Short press to load a camera setting. The buttons only work when the tracking mode is off.
6	Mute/Unmute	Mutes or unmutes the microphone. Long press the button to set the remote control ready for pairing.
7	Bluetooth	Long press to enable other Bluetooth devices to find the device.
8	Tracking Mode	Enables or disables the tracking mode.
9	Answer	Answers an incoming call or holds/resumes a Microsoft Skype for Business or Teams call.
10	Hang Up	Hangs up a call.

Poly Studio Privacy Shutter

The Poly Studio USB video bar provides a physical cover on the camera lens to protect your privacy.

When you slide the shutter lever to the left, the shutter opens and the camera captures the room.

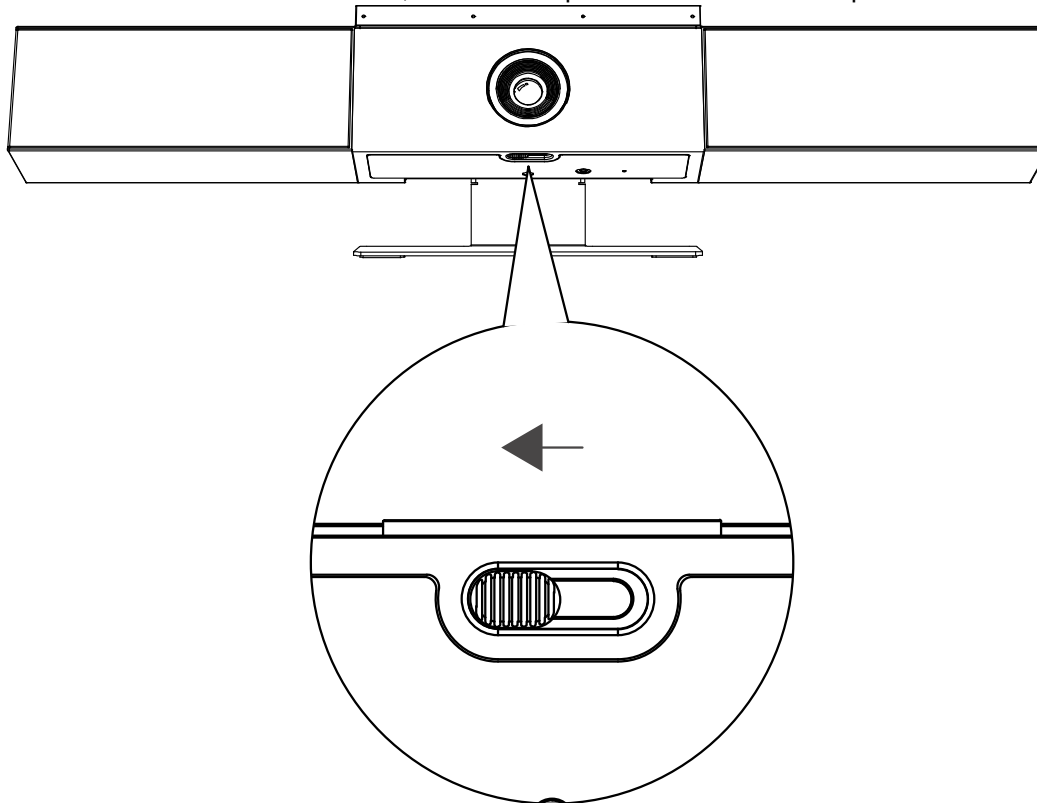

When you slide the lever to the right, the shutter closes and the camera turns off.

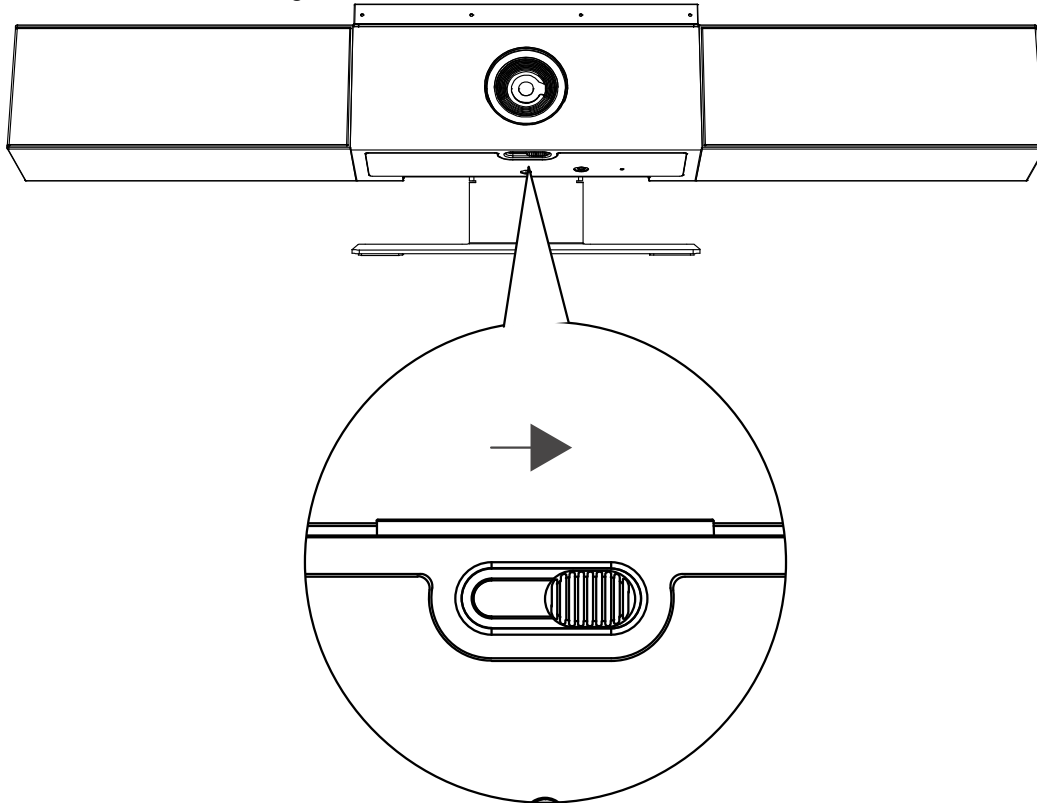

If you close the camera privacy shutter during a call, the camera status changes from working to standing by, and the LED lights turn to solid amber.

Accessibility Features

Poly Studio USB video bar includes a number of features to accommodate users with disabilities.

Accessibility Feature	Description
Visual and audio notifications	LED indicators let you know when status changes, functions work, and whether features are enabled. In most cases an audio tone accompanies the LED changes.
Built-in speaker and microphone	Poly Studio USB video bar has an integrated speaker and microphone that enable you to hear audio and speak without having to use a headset.
Powerful sound detection	The microphones pick up sound within 3.66 m (12 ft). The device includes spatial audio detection to imitate life-like presence and clarity when you move.
120-degree field of view	The ultra-wide view captures your movements without needing to adjust the camera.
Automatic speaker-tracking	The camera automatically tracks and frames the speaker, enabling free movement.

Accessibility Feature	Description
Tactile buttons	The mechanical buttons on the remote control and on the device provide visual contrast to enable you to control the system and to perform tasks such as answering calls.
Adjustable volume	You can raise or lower the volume using the remote control.

Using Poly Studio

Topics:

- [Set Poly Studio as the Default Audio and Video Device](#)
- [Using Camera Presets](#)
- [Tracking Modes](#)
- [Connect Poly Studio to a Bluetooth Device](#)

Once you plug in the power cable, you can start using the Poly Studio device.

Connect the Poly Studio device to your laptop or computer with the USB cable. Additionally, you can also connect it to your Bluetooth host devices.

Set Poly Studio as the Default Audio and Video Device

If you use the Poly Studio device with a supported application for video calls, you may need to set Poly Studio as the default audio and video device for your application.

For a better experience, Poly recommends that you use your Poly device as both the audio and video device for your meetings. Mixed video and audio sources may impact the performance of certain features. Possible scenarios include:

- If you don't use the device's speaker, Audio Echo Cancellation (AEC) may not work and the camera may have issues tracking the speaker in the room.
- If you don't use the device's microphone, the LED indicator can't show the audio mute status of your meeting.

The following is a general procedure that you can refer to. Your application may use different terms or categories.

You can configure the device to use the external expansion microphone or automatically adjust the input source via provisioning. For more information, see the *Poly Studio Parameters Reference Guide*.

Procedure

1. Go to your conferencing application's **Settings**.
2. Find **Audio Device** and **Video Device**.
3. Choose **Poly Studio** as the device for each category, then select **Save**.

Note: Make sure you use the same Poly Studio audio source. For better audio quality, if you connect the Poly Studio device to a computer over USB and Bluetooth at the same time, make sure you use the USB option for both audio input and output of your meeting.

Using Camera Presets

Save two settings for pan, tilt, zoom, and focus for the Poly Studio camera.

Use the presets to adjust the camera to your saved angle directly when group framing and speaker tracking mode is off.

Note: In Poly Lens Desktop, preset is known as **Favorites**.

Save a Camera Preset

The two numbered buttons on the Poly Studio remote control serve as preset shortcuts.

Turn off group framing and speaker tracking mode before you use camera presets.

Procedure

1. Adjust the camera to the desired position.
2. Long press the **1** or **2** button on the remote control.

The middle LED lights glow white for 3 seconds with a notification sound.

Important: If the button already has a saved setting, your new setting overwrites it.

Load a Camera Preset

If your camera doesn't track the speaker, use the preset buttons on the remote control to adjust the camera angle.

Turn off group framing and speaker tracking mode before you use camera presets.

Procedure

- » Press the **1** or **2** button on the remote control to load the camera preset for the corresponding button.

Tracking Modes

Besides the general group framing and speaker tracking mode, Poly Studio provides more modes for specific scenarios like conversations or presentations.

The group framing and speaker tracking mode supports 4× digital zoom at most, while the manual zoom supports up to 5×.

Note: You can enable only one mode at a time.

Conversation Mode

Conversation mode frames two speakers separately and puts them on the same window in a split view.

Note: Conversation mode is a Labs Feature that has not been fully tested or supported.

When there's a continuous and well-balanced conversation between two participants in the meeting, the device's camera moves to conversation mode from the group view. Note that the following scenarios don't evoke conversation mode:

- One of the speakers talks too little or too much.
- Both speakers talk at the same time.
- More than two speakers talk while taking turns.

Conversation mode automatically ends when a third participant starts talking.

Related Links

[Enable Conversation Mode](#) on page 26

Presenter Mode

Presenter mode frames the main speaker in your meeting room and follows the speaker when the speaker moves.

You can enable presenter mode for meetings where one person is the primary presenter or for distance learning so the camera always shows the instructor. The camera zooms in to capture both the presenter and the presentation background (for example, a large screen or a whiteboard) and follows the presenter's movement.

Presenter mode ends automatically in the following situations:

- Someone other than the speaker faces the device and starts talking.
- The presenter stops talking for a while.
- The presenter walks off camera.

To ensure the best performance of presenter mode, do the following:

- Place the device within 3 m (10 ft) of the speaker.
- Position the device so the camera is level with the speaker's upper chest instead of eye level. This enables the camera to capture most of the speaker's body along with the presentation background.

If you position the camera at the speaker's eye level, the device may be positioned too high to capture all the content on the screen. If you position the camera lower than the speaker's upper chest, the speaker's head may not appear in the camera view.

Related Links

[Enable Presenter Mode](#) on page 26

Connect Poly Studio to a Bluetooth Device

Connect the Poly Studio device to a Bluetooth device and use it as the speaker and microphone of the Bluetooth device.

You can pair the Poly Studio device with a mobile phone, a computer or laptop, or a tablet.

Note: The Poly Studio device doesn't support mixed types of audio and video input. If you connect it to a computer over USB and Bluetooth at the same time, make sure that your application uses both audio and video input from the Poly Studio device over USB.

Poly Studio only supports one Bluetooth connection at a time, but you can connect it to a computer over USB and to a phone over Bluetooth.

Procedure

1. On the remote control, long press **Bluetooth**  to enable the pairing mode.
The LED lights blink blue in the middle during the pairing process.
2. On your device, enable Bluetooth and select **Poly Studio** from the list of available devices.
The middle LED lights keep solid blue for three seconds with a notification sound.

You can start playing music or make phone calls from the Poly Studio speakerphone once you connect.

Configuring Poly Studio Using Polycom Companion

Topics:

- [Initialize the Poly Studio Device Using the Setup Wizard](#)
- [View Poly Studio Information](#)
- [Updating the Poly Studio Firmware](#)
- [Poly Studio User Settings](#)
- [Poly Studio Admin Settings](#)

You can configure the Poly Studio USB video bar using the Polycom Companion application.

You can configure the following settings on the Polycom Companion application:

- Audio and video configurations
- Camera control
- Wi-Fi and Bluetooth configurations
- Provisioning configuration
- Software upgrade and reset
- Downloading logs
- Audio test

The Acoustic Fence with Beam Shaping feature and stereo sound are off by default. You must use the Polycom Companion application to enable them. Download the application at the [Poly Online Support Center](#).

Related Links

[Poly Studio Overview](#) on page 5

Initialize the Poly Studio Device Using the Setup Wizard

When you start up the Poly Studio device for the first time, or after you factory reset the system, the setup wizard leads you through the minimum configuration steps.

Ask your network administrator for the provisioning server used in your deployment before you choose the **Server Type**.

Note: If you select **Auto** provisioning mode, make sure that you already have the provisioning server address, username, and password in your DHCP option 66 or 150. For example, `https://username:password@company.com`.

Procedure

1. Connect the Poly Studio device to your computer, then select the Poly Studio USB video bar tile from your Polycom Companion.
2. Enter the administrator password in the **Password** field (the default password is Polycom12#\$).
3. Accept the *End User License Agreement*, and select **Sign In**.
4. Change the default password:
 - Select the **Simple Password** check box to enter a simple password.
 - Enter a password that adheres to the on-screen requirements.
5. Select **Confirm**.
6. Select your country, and select **Next**.
7. Optional: Change the device name, or select **Skip**.
8. Optional: Configure Wi-Fi network settings, or select **Skip** to ignore the settings.

Option	Description
Wi-Fi Status	Selects On to enable the Wi-Fi function.
Wi-Fi List	Shows a list of available Wi-Fi networks.
Autoconnect	Selects On to connect to the specified Wi-Fi automatically when it's available.
Join Other Network	Specifies the network name manually in the SSID field.

9. Optional: Select **Skip** to ignore provisioning server settings, or select **Provisioning Mode** and choose one of the following options:
 - **Disable**: Disables the provisioning mode.
 - **Auto**: Gets the provisioning server URL from your DHCP option 66 or 150.
 - **Manual**: Configure the following parameters:

Parameter	Description
Server Type	Select a server type from the drop-down menu: Choose Polycom Provisioning Services for Poly Lens, PDMS-E, or Polycom RealPresence Resource Manager. Choose HTTPS Server and FTPS Server for your own provisioning server.
Server Address	Specifies the server address.
User name and Password	Specifies the username and password to log in to the provisioning server.

10. Select **Finish**.

View Poly Studio Information

You can view the basic information for your Poly Studio device through Polycom Companion.

Procedure

1. Connect the Poly Studio device to your computer, then select the Poly Studio USB video bar tile in Polycom Companion.
2. In the **Status** section, view the basic information for your Poly Studio device.
3. Optional: If you see the following warning message in the **Status** section, contact Poly Support to report the issue and the values of the **Device Diagnostic Code** field: `There is an internal issue with your device. Please contact Poly support.`

If there is no warning message, you can ignore the **Device Diagnostic Code** field.

Updating the Poly Studio Firmware

You can update the firmware for your Poly Studio USB video bar using Polycom Companion or directly from your local computer.

Update the Poly Studio Firmware from Your Computer

You can update the firmware from your computer to load beta firmware or if you have a problem with the automatic firmware update.

For beta firmware, download the beta firmware to your computer. The link to the beta firmware is on the beta software download page.

Note: If you download the firmware package using Internet Explorer, you may need to change the file extension from `.zip` to `.dfu`.

Note the following about manual firmware updates:

- Use the automatic firmware update whenever possible.
- You can't update the firmware while the Poly Studio device is streaming video or audio.

Procedure

1. Connect the Poly Studio device to your computer, then select the Poly Studio USB video bar tile in Polycom Companion.
2. Select the **Firmware Update** tab.
3. Select **Update from Local File** and choose the software build you want to use.

The Polycom Companion application updates the Poly Studio device to the version that you select.

Update the Poly Studio Device and the Remote Control

You can use the Polycom Companion application to update the firmware of the Poly Studio device and the remote control.

After the Poly Studio device connects to your computer, the application checks for a new software version from the server automatically. If the app detects a new version, the app displays a red dot on the **Firmware Update** tab as a reminder.

Note: Make sure your computer doesn't enter sleep mode during the firmware update. Otherwise, the update may fail.

Procedure

1. Connect the Poly Studio device to your computer, then select the Poly Studio USB video bar tile from your Polycom Companion.
2. Select the **Firmware Update** tab.
The application shows the current version and new version.
3. Select **Update** to update a Poly Studio USB video bar device or a remote control in active mode.

Note: If the remote control is in sleep mode, you can press any button to wake up the remote control.

4. Enter the administrator password to start the update (the default password is `Polycom12#$`).

Note: Do not disconnect the Poly Studio device while installing the update. If it disconnects unexpectedly, you must finish the update immediately after reconnecting it.

The application displays the new version number and **Up-to-Date** after the update installs.

Poly Studio User Settings

You can configure camera and audio settings, control the camera, and pair your device to the Poly Studio USB video bar device through Polycom Companion.

Caution: Don't unplug the USB cable or power cable of the Poly Studio USB video bar device while changing the its settings on the Polycom Companion. This may cause unexpected errors.

Control the Device Camera

You can enable speaker tracking and control the camera on the Poly Studio device through Polycom Companion.

Procedure

1. Connect the Poly Studio device to your computer, then select the Poly Studio USB video bar tile from your Polycom Companion.
2. Go to **User Settings > Camera Control**.
3. Control the Poly Studio device through the following functions:

Button Name	Description
Zoom In or Out	Adjusts camera zoom in or out when the Tracking Mode is off.
Adjust Camera Directions	Adjusts the direction of camera when the Tracking Mode is off.
Preset 1 or 2	<ul style="list-style-type: none"> ▪ Select a preset card, and select Save to save a camera setting. ▪ Select a preset card, and select Select to load a camera setting.

Configure Advanced Camera Settings

You can improve the video quality of the Poly Studio device by configuring advanced camera settings.

Room lighting can affect video quality. If the room is too bright or too dark for camera tracking to work properly, you can improve the video quality by adjusting certain settings in Polycom Companion.

Procedure

1. Connect the Poly Studio device to your computer, then select the Poly Studio USB video bar tile from your Polycom Companion.
2. Go to **User Settings > Camera Control**.
3. Select **Advanced Camera Settings**.
4. Configure the following camera settings:

Camera Setting	Description
Brightness	Use the slider to adjust image brightness.
Contrast	Use the slider to adjust image contrast.
Saturation	Use the slider to adjust color saturation.
Sharpness	Use the slider to adjust video sharpness.
White Balance	<p>Specifies how the camera compensates for variations in room light sources.</p> <p>Select Auto or adjust the value manually. If you adjust manually, select a color temperature value. The color temperature values, measured in degrees Kelvin, correspond to the color of the ambient light in a room.</p>
Gain	Use the slider to adjust the signal amplification from the camera.
Backlight Comp	Enables or disables backlight compensation.
PowerLine Frequency (Anti Flicker)	Change the number to prevent flicker in the video.

5. Do one of the following:

- (Windows) Select **Apply** to save the changes or **Default** to restore the default settings.
 - (Mac) Select **Save** to save the changes or **Reset** to restore the default settings.
6. (Only for Windows) Select **Camera Control** to control the camera:

Settings	Description
Zoom	Adjust camera zoom in or out.
Exposure	Set the exposure number.
Pan	Adjust the left or right direction of the camera.
Tilt	Adjust the up or down direction of the camera.

7. Select **OK**.

Pair the Poly Studio Device to a Bluetooth Device

Connect the Poly Studio device to a Bluetooth device and use it as the speaker and microphone of the Bluetooth device.

You can pair the Poly Studio device with a mobile phone, a computer or laptop, or a tablet.

Note: The Poly Studio device doesn't support mixed types of audio and video input. If you connect it to a computer over USB and Bluetooth at the same time, make sure that your application uses both audio and video input from the Poly Studio device over USB.

Procedure

1. Connect the Poly Studio device to your computer, then select the Poly Studio USB video bar tile from your Polycom Companion.
2. Go to **User Settings > Bluetooth Pair Mode**.
3. Select **Start Pairing**.
4. On your device, enable Bluetooth and select **Poly Studio** from the list of available devices.

You can start playing music or make phone calls from the Poly Studio speakerphone once you connect.

Configuring Audio Settings

You can enhance the Poly Studio device audio experience, for example, by enabling audio stereo or boosting the bass.

Enable NoiseBlockAI

When you enable NoiseBlockAI, the Poly Studio device automatically senses the ambient noise in the room and prevents the noise from transmitting to the far-end during video conferences.

Procedure

1. Connect the Poly Studio device to your computer, then select the Poly Studio USB video bar tile from your Polycom Companion.
2. Go to **User Settings > Audio Settings**.
3. Set the **NoiseBlockAI** option to **On**.

Enable Stereo Audio

When you enable stereo audio, the Poly Studio device uses two audio channels to provide stereo sound in a conference.

Procedure

1. Connect the Poly Studio device to your computer, then select the Poly Studio USB video bar tile from your Polycom Companion.
2. Go to **User Settings > Audio Settings**.
3. Set the **Stereo** option to **On**.

Enable Stereo Audio for Skype for Business

When you enable stereo audio for Skype for Business, the Skype for Business audio outputs are stereo. The item is available when you enable the **Stereo** option.

This feature is available in the Windows version of Polycom Companion only.

Procedure

1. Connect the Poly Studio device to your computer, then select the Poly Studio USB video bar tile from your Polycom Companion.
2. Go to **User Settings > Audio Settings**.
3. Set the **Stereo for Skype for Business** option to **On**.

Enable Audio Bass Boost

Enable this feature to amplify low frequencies in the audio output.

Procedure

1. Connect the Poly Studio device to your computer, then select the Poly Studio USB video bar tile from your Polycom Companion.
2. Go to **User Settings > Audio Settings**.
3. Set the **Bass Boost** option to **On**.

Configure Acoustic Fence

You can enable and configure the Polycom Acoustic Fence feature to help define the *audio fence* around the system.

Polycom Acoustic Fence technology creates a virtual *audio fence* that blocks sounds from outside the fence. It suppresses background noise during calls to enhance audio quality for call participants. The Poly Studio device defines the audio fence zone in a beam shape with three width options. The system picks up sounds within the beam region and sends only those sounds to the far end.

Procedure

1. Connect the Poly Studio device to your computer, then select the Poly Studio USB video bar tile from your Polycom Companion.
2. Go to **User Settings > Audio Settings**.
3. Select one of the following options for **Acoustic Fence**:
 - **Off**: Disable Acoustic Fence
 - **Wide**: Set a 120-degree beam region

- **Medium:** Set a 90-degree beam region
- **Narrow:** Set a 60-degree beam region

Poly Studio Admin Settings

You can configure Wi-Fi and Bluetooth, provision the Poly Studio USB video bar server, restart or factory reset the device, and import or export configuration files through the admin settings menu.

Caution: Don't disconnect the USB cable or power cable of the Poly Studio device while changing the settings on the Polycom Companion App. This may cause unexpected errors.

Log In to Poly Studio Admin Settings

You must enter the administrator password to log in to the **Admin Settings** menu.

Procedure

1. Connect the Poly Studio device to your computer, then select the Poly Studio USB video bar tile in Polycom Companion.
2. Select **Admin Settings**.
3. Enter the administrator password in the **Password** field (the default password is Polycom12#\$).
4. Select **Sign In**.

Change Your Password

Poly requires that you change your device's password from the default for security reasons.

Procedure

1. Connect the Poly Studio device to your computer, then select the Poly Studio USB video bar tile in Polycom Companion.
2. Go to **Admin Settings > Password Settings**.
3. Enter your **Current Password**.
4. Enter a new password in **New Password** and **Confirm Password** fields.
 - Select the **Simple Password** check box to enter a simple password.
 - Enter a password that adheres to the onscreen requirements.
5. Select **Save**.

Configure General Settings

You can configure the device name and NTP settings for the Poly Studio device.

Procedure

1. Connect the Poly Studio device to your computer, then select the Poly Studio USB video bar tile in Polycom Companion.
2. Go to **Admin Settings > General Settings**.
3. Configure the following settings:

Parameter	Description
Device Name	Specifies the name of the Poly Studio device.
NTP Mode	Selects the NTP mode. If you select Manual , specify the NTP Server manually.
NTP Server	Specifies the NTP server IP address. Only available when you select Manual in NTP Mode .
Camera Vivid Mode	Specifies whether to let the camera accentuate red, green, or blue colors to make the video more vivid.

4. Select **Save**.

Configuring Camera Tracking

The Poly Studio device can detect the people in the room and provide framing during a conference.

You can set the tracking mode, tracking speed, and tracking framing size. Camera tracking enables automatic tracking of group participants or the active speaker in the room.

Configure Camera Tracking Mode

You can configure the Poly Studio device to track the group participants in the room, track only the active speaker, or disable camera tracking.

When you enable **Camera Tracking**, **Tracking On**  appears on the upper-right corner of the **Camera Control** window. When you disable **Camera Tracking**, **Tracking Off**  appears instead.

Procedure

1. Connect the Poly Studio device to your computer, then select the Poly Studio USB video bar tile in Polycom Companion.
2. Go to **Admin Settings > Camera Tracking > Tracking Mode** and select one of the following options:
 - **Frame Group**: The camera automatically frames the participants in the room.
 - **Frame Speaker**: The camera zooms in on an active speaker without use of a remote control or camera preset.
 - **Off**: Disables the camera tracking.

Note: To use the camera pan, tilt, and zoom options, you must set **Tracking Mode** to **Off**.

3. Select **Save**.

Configure Camera Tracking Speed

You can configure the camera tracking speed of the Poly Studio device.

Procedure

1. Connect the Poly Studio device to your computer, then select the Poly Studio USB video bar tile in Polycom Companion.
2. Go to **Admin Settings > Camera Tracking > Tracking Speed** and select one of the following options:

- **Normal**(default): Detects meeting participants at a normal speed rate.
 - **Slow**: Detects meeting participants at a slow speed rate.
 - **Fast**: Detects meeting participants at a fast speed rate.
3. Select **Save**.

Configure Camera Tracking Framing Size

You can configure the Poly Studio device tracking framing view.

Procedure

1. Connect the Poly Studio device to your computer, then select the Poly Studio USB video bar tile in Polycom Companion.
2. Go to **Admin Settings > Camera Tracking > Framing Size** and select one of the following options:
 - **Tight**: Establishes a close-up view of meeting participants.
 - **Medium**(default): Establishes a medium view of meeting participants.
 - **Wide**: Establishes a wide view of meeting participants.
3. Select **Save**.

Configure Maximum Zoom

You can limit the maximum camera zoom in ratios of 2x, 3x, or 4x only when the tracking mode is **Frame Group** or **Frame Speaker**.

Procedure

1. Connect the Poly Studio device to your computer, then select the Poly Studio USB video bar tile in Polycom Companion.
2. Go to **Admin Settings > Camera Tracking > Maximum Zoom** and select one of the zoom ratios.
3. Select **Save**.

Configure Camera Movement

You can adjust the camera movement only when you set the tracking mode to **Frame Group** or **Frame Speaker**.

Procedure

1. Connect the Poly Studio device to your computer, then select the Poly Studio USB video bar tile in Polycom Companion.
2. Go to **Admin Settings > Camera Tracking > Camera Movement** and select one of the following options:
 - **Auto Pan**: The camera pans smoothly between the speakers or groups.
 - **Cut**: The video cuts between the talkers or groups.
3. Select **Save**.

Enable Conversation Mode

You can enable your device to track speakers in a conversation.

You can't enable **Presenter Mode** and **Conversation Mode** at the same time.

Procedure

1. Connect the Poly Studio device to your computer, then select the Poly Studio USB video bar tile in Polycom Companion.
2. Go to **Admin Settings > Camera Tracking** and configure the following settings:
 - Set **Tracking Mode** to **Frame Speaker**.
 - Set **Maximum Zoom** to **4x**.
3. Go to **Admin Settings > Lab Feature > Conversation Mode** and select one of the following options:
 - **On**: Captures two speakers in a discussion who are far apart. The Poly Studio device performs a split screen showing the two speakers together. The maximum zoom-in ratio is fixed to **4x** at the same time.
 - **Off**: The Poly Studio device tracks the speaker who is currently talking.

Related Links

[Conversation Mode](#) on page 14

Enable Presenter Mode

You can enable your device to track an active speaker who's talking and moving.

You can't enable **Presenter Mode** and **Conversation Mode** at the same time.

Procedure

1. Connect the Poly Studio device to your computer, then select the Poly Studio USB video bar tile in Polycom Companion.
2. Go to **Admin Settings > Camera Tracking** and configure the following settings:
 - Set **Tracking Mode** to **Frame Speaker**.
 - Set **Maximum Zoom** to **4x**.
3. Go to **Admin Settings > Lab Feature > Presenter Mode** and select one of the following options:
 - **On**: Captures the active speaker.
 - **Off**: Stops capturing the active speaker.

Related Links

[Presenter Mode](#) on page 14



Join a Wi-Fi Network

You can connect the Poly Studio device to Wi-Fi through Polycom Companion.

Note: Poly Studio doesn't store data or time information in the device itself. Therefore, if you configure it to verify certificates when connecting to a Wi-Fi network from the Polycom Companion app, disconnect from the Polycom Companion app, and then reboot the device, Poly Studio can't automatically reconnect to the Wi-Fi network due to a verification failure that comes from the inconsistent time information.

Procedure

1. Connect the Poly Studio device to your computer, then select the Poly Studio USB video bar tile from your Polycom Companion.
2. Go to **Admin Settings > Wi-Fi Settings**.
3. Select **On** in **Wi-Fi Status** to enable the Poly Studio USB video bar Wi-Fi function.

After you connect to a Wi-Fi network, connection status icon changes from **Disabled**  to **Enabled** .

4. Do one of the following:
 - Select a network from **Wi-Fi Name**. The app lists networks in order of signal strength.
 - Select **Autoconnect** to connect to the specified Wi-Fi network automatically when it's available.
 - Select **Join Other Network** and specify the network name manually in the **SSID** field.

Selecting a new SSID erases the previous SSID and relevant Wi-Fi settings from the system.

5. Configure the following Wi-Fi settings. Available settings vary with your selections.

Setting	Description
Security	Specifies the encryption protocol: <ul style="list-style-type: none"> ▪ None ▪ WEP ▪ WPA/WPA2/FT PSK ▪ 802.1x EAP
EAP Method	Specifies the EAP for WPA-Enterprise (802.1xEAP): <ul style="list-style-type: none"> ▪ PEAP ▪ TLS ▪ TTLS ▪ PWD
Phase 2 Authentication	Specifies the phase 2 authentication method. Available options vary with the selected EAP method. <ul style="list-style-type: none"> ▪ None ▪ MSCHAP ▪ MSCHAPV2 ▪ GTC ▪ PAP
CA Certificate	Specifies the CA certificate: <ul style="list-style-type: none"> ▪ <InstalledCAName>— Selects from installed CA list. ▪ Do not validate

Setting	Description
User Certificate	Selects from the Installed User CA Name list.
Identify	Specifies your identity.
Anonymous Identify	Specifies an anonymous identity to protect your real identity.
Password	Specifies the login password.
Show password	Selects the check box to reveal your password instead of dots.
Show advanced settings	Selects the check box to configure IP settings.
IP Setting	Specifies one method to set your network IP address: <ul style="list-style-type: none"> ▪ Static: specifies the IP settings manually. ▪ DHCP: obtains the IP settings automatically.
IP Address	<ul style="list-style-type: none"> ▪ To set your system Wi-Fi network IP address, select Obtain IP address automatically. (You must have a DHCP server in your environment to use this option.) ▪ To enter a specific Wi-Fi network IP address, select Enter IP address manually.
Gateway	Specifies the gateway of the network.
Subnet Mask	Specifies the subnet mask address for the Wi-Fi network. This setting is read-only if your system gets its IP address automatically.
DNS Address 1	Specifies the DNS server address of the network.
DNS Address 2	Specifies the alternate DNS server address of the network.

6. Select **Join** to connect to the Wi-Fi network.

Delete Known Wi-Fi Networks

You can delete the known Wi-Fi networks from Polycom Companion.

Procedure

1. Connect the Poly Studio device to your computer, then select the Poly Studio USB video bar tile from your Polycom Companion.
2. Go to **Admin Settings > Wi-Fi Settings**.
3. Select **Manage Known Networks**.
4. Choose the Wi-Fi network you want to delete.
5. Select **X**.

Configure Bluetooth Settings

You can turn on the Bluetooth function of the Poly Studio device through Polycom Companion.

Procedure

1. Connect the Poly Studio USB device to your computer, then select the Poly Studio USB video bar tile from your Polycom Companion.
2. Go to **Admin Settings > Bluetooth**.
3. Set the **Bluetooth Status** option to **On** to enable Bluetooth on the Poly Studio device.
4. Unselect the **Autoconnect** check box if you don't want your device connects to the Poly Studio device automatically via Bluetooth.

Note: To enhance your privacy security, forget or remove Poly Studio from your device's paired device list. This prevents your device from sending a request to automatically connect to Poly Studio.

5. Set the **Remote Control Connection** option to **On** to enable the connection between the Poly Studio device and remote control.

Note: If you disable the **Remote Control Connection**, the Poly Studio remote control disconnects from the Poly Studio device. Pair the remote control manually after you re-enable the **Remote Control Connection**.

Configure a Provisioning Server for the Poly Studio Device

You can configure a provisioning server for the Poly Studio device through Polycom Companion.

Make sure that the Poly Studio device connects to a Wi-Fi network before connecting it to a provisioning server.

Ask your network administrator for the provisioning server used in your deployment before you choose the **Server Type**.

Note: If you select **Auto** provisioning mode, make sure that you already have the provisioning server address, username, and password in your DHCP option 66 or 150. For example, `https://username:password@company.com`.

Procedure

1. Connect the Poly Studio device to your computer, then select the Poly Studio USB video bar tile from your Polycom Companion.
2. Go to **Admin Settings > Provisioning Server**.
3. Select **Provisioning Mode** and choose one of the following options:
 - **Disable:** Disables the provisioning mode.
 - **Auto:** Gets the provisioning server URL from your DHCP option 66 or 150.
 - **Manual:** Configure the following parameters:

Parameter	Description
Server Type	<p>Selects one server type from the drop-down menu.</p> <p>Selects Polycom Provisioning Services for PDMS-E or Polycom RealPresence Resource Manager.</p> <p>Use HTTPS Server and FTPS Server for your own provisioning server.</p>
Server Address	Specifies the server address.
User name and Password	Specifies the username and password to log in to the provisioning server.

4. Select **Save**.

You can check the provisioning status in **Status > Provisioning Server**.

For information about the parameters that Polycom RealPresence Resource Manager system or the PDMS-E service uses to manage your Poly Studio device, see the *Poly Studio Parameters Reference Guide* available at the [Poly Documentation Library](#).

Certificate Signing Requests

The Polycom Companion application can generate certificate signing requests (CSRs) that are then sent to a certificate authority (CA) for official issuance. The CA is the trusted entity that issues, or signs, digital certificates for others.

Note: If you use a certificate chain for authentication, the EAP-TLS connection with wireless networks fails for Poly Studio.

Enable Peer Certificate Validation

You can enable the peer certificate option to validate your provisioning server automatically.

Before you enable this setting, you must first install the CA certificates needed to validate your provisioning server certificates.

Procedure

1. Connect the Poly Studio device to your computer, then select the Poly Studio USB video bar tile in Polycom Companion.
2. Go to **Admin Settings > Certificates**.
3. Set the **Always Validate Peer Certificates From Server** option to **On**.

Create a Certificate Signing Request

You can create a Certificate Signing Request (CSR) and send it to a CA to get a certificate to authenticate your USB device. You may need to authenticate your USB device while connecting to your provisioning server.

Note: To create a **Provisioning User Certificate**, you must use the Polycom Companion application to generate the CSR.

Procedure

1. Connect the Poly Studio device to your computer, then select the Poly Studio USB video bar tile in Polycom Companion.
2. Go to **Admin Settings > Certificates**.
3. Select **Create**.
4. Configure the following settings on the **Create Signing Request** page:

Field	Description
Country	Specifies the country where your organization is located.
State or Province	Specifies the state or province where your organization is located. Default is blank. Maximum characters: 128.
City or Locality	Specifies the city where your organization is located. Default is blank. Maximum characters: 128.
Organization	Specifies your organization name.
Organizational Unit	Specifies the unit of business defined by your organization. Default is blank. Maximum characters: 64.
Common Name	<p>Specifies the name that the system assigns to the CSR.</p> <p>Use the following guidelines when configuring the Common Name:</p> <ul style="list-style-type: none"> ▪ For systems registered in DNS, use the FQDN of the system. ▪ For systems not registered in DNS, use the IP address of the system. Default is blank. Maximum characters: 64; truncated if necessary.

5. Select **Create**.

The system displays a message indicating that you created the CSR.

6. Select **Download** to download the CSR.

You must send the CSR to your CA for signature. Normally, you log into the website of your CA and paste your CSR content into a form to submit it.

Install a Certificate

After a CA signs your certificate, you can install it on the Poly Studio device.

You can install one certificate for each certificate type. If the system has an existing certificate for your certificate type, installing a new one overwrites it.

Note: A factory reset or factory restore deletes all installed certificates.

Procedure

1. Connect the Poly Studio device to your computer, then select the Poly Studio USB video bar tile in Polycom Companion.
2. Go to **Admin Settings > Certificates**.
3. Select **Install** and choose one of the following options:
 - **Wi-Fi CA Certificate:** Certificate to authenticate the Certificate authority (CA) of the Wi-Fi network
 - **Wi-Fi User Certificate:** Certificate to authenticate users who are connecting to this Wi-Fi network
 - **Provisioning CA Certificate:** Certificate to authenticate the Certificate authority (CA) of the provisioning server
 - **Provisioning User Certificate:** Certificate to authenticate users who are connecting to the provisioning server
4. Select a signed certificate from your local disk. For **Wi-Fi User Certificate**, enter the **Private Key Password** and select **Next**.

The system displays a message indicating the installation result.

Supported Certificate Formats

Supported certificate formats vary with your certificate type.

The following table lists the supported certificate formats by type.

Supported Certificate Formats

Certificate Type	Format
Wi-Fi CA Certificate	.pem, .crt
Wi-Fi User Certificate	.p12
Provisioning CA Certificate	.pem, .crt
Provisioning User Certificate	.pem, .crt

View Installed Certificate Details

You can view the content of an installed certificate.

Procedure

1. Connect the Poly Studio device to your computer, then select the Poly Studio USB video bar tile in Polycom Companion.
2. Go to **Admin Settings > Certificates**.
3. Select the certificate you want to view in the **Installed Certificates** table.
The **Certificate Details** window opens.
4. To close the certificate details window, select **Close**.

Delete an Installed Certificate

You may need to remove an expired certificate to install a newer version.

When a certificate expires, its **Expiration Date** turns red in the **Installed Certificates** table.

Procedure

1. Connect the Poly Studio device to your computer, then select the Poly Studio USB video bar tile in Polycom Companion.
2. Go to **Admin Settings > Certificates**.
3. Select the certificate you want to delete in the **Installed Certificates** table.
4. At the bottom of the **Certificate Details** window, select **Delete**.

Import a Configuration File

You can import a configuration file from your local system to the Poly Studio device.

Procedure

1. Connect the Poly Studio device to your computer, then select the Poly Studio USB video bar tile in Polycom Companion.
2. Go to **Admin Settings > Configuration**.
3. Select **Import**.
4. Select the local configuration file you want to import.
5. Select **OK**.
6. Restart the Poly Studio device for the changes to take effect.

Export a Configuration File to Your Local System

You can export the Poly Studio configuration file from Polycom Companion to your local system.

Procedure

1. Connect the Poly Studio device to your computer, then select the Poly Studio USB video bar tile in Polycom Companion.
2. Go to **Admin Settings > Configuration**.
3. Select **Export** and select a directory to save the configuration file to.
4. Select **Save**.

Troubleshooting

Topics:

- [Identifying Issues Using the LED Indicators](#)
- [Restart Your Poly Studio Device](#)
- [Restore Default Settings](#)
- [Factory Reset Poly Studio](#)
- [Factory Reset Your Poly Studio Device Using Polycom Companion](#)
- [Pair the Bluetooth Remote Control with Poly Studio](#)
- [Troubleshoot the Remote Control](#)
- [Test Your Camera Audio Input](#)
- [Display Camera Information On-Screen](#)
- [Download Log and Crash Files](#)
- [Can't Upgrade, Reset, or Reboot Poly Studio via Polycom Companion](#)

If you experience issues with your Poly Studio device, try the following solutions to resolve certain issues.

Identifying Issues Using the LED Indicators

The LED indicators provide troubleshooting information for your Poly Studio device.

Poly Studio LED Troubleshooting Indicators and Status

Indicator	Position	Status
Blinking red	All	Error preventing normal operation
Pulsing amber	All	Update in progress

Restart Your Poly Studio Device

You can restart your Poly Studio device from Polycom Companion.

Procedure

1. Connect the Poly Studio device to your computer, then select the Poly Studio USB video bar tile in Polycom Companion.
2. Go to **Admin Settings > System Restart**.
3. Select **Restart**.

Restore Default Settings

You can erase all configurations and restore the Poly Studio USB video bar default settings.

Use the Polycom Companion application to configure some of the settings. The default settings that the system clears include the following (not an exhaustive list):

- Password
- Remote control presets
- Wi-Fi settings
- Camera settings
- Audio settings
- Bluetooth settings
- System information (such as system name)
- Logs

The current version of software remains the same after restoring.

Procedure

- » Plug in the power cord and press the **Reset** button on the bottom of the device for 10 seconds. The LED lights begin chasing white, then turn to solid amber.

Note: If the Poly Studio camera is in use, such as in a call or in **Camera Preview** on the client, the **Reset** button doesn't work.

The Poly Studio device clears all saved settings and logs and reboots.

Restoring the defaults unpairs the remote control. Re-pair the remote control after the Poly Studio device reboots.

Factory Reset Poly Studio

You can reset the Poly Studio device to factory settings if persistent issues remain after troubleshooting.

Warning: Your device returns to the factory software version and erases all configuration and logs.

Resetting the device to factory settings unpairs the remote control. You must re-pair the remote control with the Poly Studio device after you reset the system.

Procedure

1. Disconnect the Poly Studio device to turn it off.
2. Find the reset pinhole on the bottom of the device.
3. Use a pin or paperclip to press and hold the reset button and plug in the device at the same time to turn it on.

The Poly Studio device reboots with pulsing amber LED lights.

The Poly Studio device rolls back to the factory software version and loses all configuration and logs.

Factory Reset Your Poly Studio Device Using Polycom Companion

You can factory reset your Poly Studio device, which removes all configurations and stored settings.

Procedure

1. Connect the Poly Studio device to your computer, then select the Poly Studio USB video bar tile in Polycom Companion.
2. Go to **Admin Settings > Factory Reset**.
3. Select **Reset**.
4. Select **OK** to confirm the factory reset.

The system restarts automatically.

Pair the Bluetooth Remote Control with Poly Studio

If you reset or restore your Poly Studio device or replace the remote control, you must pair the remote control to the device.

Procedure

1. Optional: If you want to replace an old remote control, remove the battery to disable it.
2. Press and hold the **Remote Control Pairing**  button on the bottom of the device until the LEDs blink blue in the middle with a notification sound.

The LED lights blink blue in the middle during the pairing process.

3. Long press **Mute**  on the remote control until you hear a notification sound.

The middle LED lights keep solid blue for three seconds with a notification sound.

Troubleshoot the Remote Control

When the remote control power is lower than 7%, its performance becomes unstable.

You may experience issues like slow or no response from the remote control, or a random button keeps functioning.

Procedure

1. Go to Polycom Companion to check the battery status.
2. If the battery runs out of power, change the battery. Refer to the *Poly Studio Setup Sheet* for details.

Test Your Camera Audio Input

If you have audio problems when using your Poly Studio device, you may need to send an audio test file to Poly Online Support Center for troubleshooting.

Procedure

1. Connect the Poly Studio device to your computer, then select the Poly Studio USB video bar tile from your Polycom Companion.
2. Go to **Diagnostics > Audio Test**.
3. Select **Start Test** and speak into the Poly Studio device.

The test recording window lasts at most 3 minutes, or you can click **Stop** to stop the recording.

4. Save the recording file to your local system and play it back to listen for any audio issues.

Display Camera Information On-Screen

You can display the camera information of your Poly Studio device on your video output.

Note: Depending on the application using the Poly Studio device, the resolution displayed on the video output doesn't necessarily reflect the maximum resolution supported by the Poly Studio device.

Procedure

1. Connect the Poly Studio device to your computer, then select the Poly Studio USB video bar tile in Polycom Companion.
2. Go to **Diagnostics > On-Screen Display**.
3. Select **On**.

The camera parameters for your Poly Studio device display on the video output.

Download Log and Crash Files

You can download the Poly Studio USB video bar log and crash files to assist in troubleshooting.

Procedure

1. Connect the Poly Studio device to your computer, then select the Poly Studio USB video bar tile from your Polycom Companion.
2. Go to **Diagnostics > Logs**.
3. Select **Download** under **Logs** to download Poly Studio USB video bar system logs.
4. Select **Download** under **Crash Files** to download Poly Studio USB video bar system crash log files.

Can't Upgrade, Reset, or Reboot Poly Studio via Polycom Companion

When you use the **Firmware Update**, **System Restart**, or **Factory Restart** functions on Polycom Companion, the application prompts an error message.

Problem:

When the camera of Poly Studio is in use, resetting, upgrading, or restarting the Poly Studio device doesn't work.

Workaround:

Make sure that the Poly Studio camera isn't in use and try again. For example, you can check whether the software client shows the video on the **Camera Preview** page using the Poly Studio device.