



Maintenance and Service Guide

SUMMARY

This guide provides maintenance information about such topics as spare parts, removal and replacement of parts, security, and backing up.

Legal information

© Copyright 2023 HP Development Company, L.P.

AMD is a trademark of Advanced Micro Devices, Inc. Bluetooth is a trademark owned by its proprietor and used by HP Inc. under license. Chrome is a trademark of Google LLC. The terms HDMI, HDMI High-Definition Multimedia Interface, and the HDMI Logo are trademarks or registered trademarks of HDMI Licensing Administrator, Inc. Intel, Core, Thunderbolt, vPro, and XMM are trademarks of Intel Corporation or its subsidiaries in the U.S. and/or other countries. Microsoft and Windows are either registered trademarks or trademarks of Microsoft Corporation in the United States and/or other countries. NVMe is a registered trademark of NVM Express. PCIe is a US registered trademark of PCI-SIG. microSD™ is a trademark or registered trademark of SD-3C LLC. USB Type-C is a registered trademark of USB Implementers Forum. DisplayPort™ and the DisplayPort™ logo are trademarks owned by the Video Electronics Standards Association (VESA) in the United States and other countries. Wi-Fi is a registered trademark of Wi-Fi Alliance.

The information contained herein is subject to change without notice. The only warranties for HP products and services are set forth in the express warranty statements accompanying such products and services. Nothing herein should be construed as constituting an additional warranty. HP shall not be liable for technical or editorial errors or omissions contained herein.

First Edition: April 2023

Document Part Number: N42048-001

Product notice

This guide describes features that are common to most models. Some features may not be available on your computer.

Not all features are available in all editions or versions of Windows. Systems may require upgraded and/or separately purchased hardware, drivers, software or BIOS update to take full advantage of Windows functionality. Windows is automatically updated, which is always enabled. High-speed internet and Microsoft account required. ISP fees may apply and additional requirements may apply over time for updates. See <http://www.microsoft.com>.

If your product ships with Windows in S

Mode: Windows in S Mode works exclusively with apps from the Microsoft Store within Windows. Certain default settings, features, and apps cannot be changed. Some accessories and apps that are compatible with Windows may not work (including some antivirus, PDF writers, driver utilities, and accessibility apps), and performance may vary, even if you switch out of S Mode. If you switch to Windows, you cannot switch back to S Mode. Learn more at Windows.com/SmodeFAQ.

To access the latest user guides, go to <http://www.hp.com/support>, and follow the instructions to find your product. Then select **Manuals**.

Software terms

By installing, copying, downloading, or otherwise using any software product preinstalled on this computer, you agree to be bound by the terms of the HP End User License Agreement (EULA). If you do not accept these license terms, your sole remedy is to return the entire unused product (hardware and software) within 14 days for a full refund subject to the refund policy of your seller.

For any further information or to request a full refund of the price of the computer, please contact your seller.

Table of contents

1 Product description	1
2 Components	5
Locating hardware	5
Locating software	5
Right	5
Left	7
Display	8
Auto Lock and Awake	8
Low blue light mode (select products only)	9
Keyboard area	10
Touchpad	10
Touchpad settings	10
Adjusting touchpad settings	10
Turning on the touchpad	10
Touchpad components	11
Lights	11
Button, speakers, and fingerprint reader	13
Special keys	14
Bottom	15
Using a SIM card (select products only)	16
Determining the correct SIM card size for your computer	16
Inserting a nano SIM card	16
Labels	17
3 Illustrated parts catalog	20
Computer major components	20
Mass storage devices	34
Cables	34
Miscellaneous parts	35
4 Removal and replacement procedures preliminary requirements	39
Tools required	39
Service considerations	39

Plastic parts.....	39
Cables and connectors.....	39
Drive handling	39
Electrostatic discharge information.....	40
Generating static electricity.....	40
Preventing electrostatic damage to equipment	41
Personal grounding methods and equipment.....	41
Grounding the work area.....	42
Recommended materials and equipment.....	42
Cleaning your computer.....	43
Enabling HP Easy Clean (select products only).....	43
Removing dirt and debris from your computer.....	43
Cleaning your computer with a disinfectant.....	44
Caring for wood veneer (select products only).....	45
Packaging and transporting guidelines.....	45
Accessing support information.....	46
5 Removal and replacement procedures for authorized service provider parts.....	48
Component replacement procedures	48
Preparation for disassembly.....	48
Bottom cover	48
Battery.....	50
Solid-state drive.....	51
WWAN module.....	53
Connector board.....	54
Display assembly.....	55
Fan/heat sink assembly.....	58
Rear speakers.....	60
System board	61
Fingerprint reader cable.....	64
Fingerprint reader.....	65
Touchpad cable.....	66
Touchpad	67
Transfer board cable.....	68
Transfer board.....	69
NFC module cable.....	70
NFC module	71
WWAN antenna.....	72
Front speakers.....	73
Top cover with keyboard.....	74
6 Computer Setup (BIOS), TPM, and HP Sure Start	76
Using Computer Setup.....	76
Navigating and selecting in Computer Setup	76
Restoring factory settings in Computer Setup.....	77
Updating the BIOS	77
Determining the BIOS version	77
Preparing for a BIOS update	77

Downloading a BIOS update	78
Installing a BIOS update	78
Changing the boot order using the f9 prompt	78
TPM BIOS settings (select products only)	79
Using HP Sure Start (select products only).....	79
7 Backing up, restoring, and recovering.....	80
Backing up information and creating recovery media.....	80
Using Windows tools for backing up.....	80
Using the HP Cloud Recovery Download Tool to create recovery media (select products only).....	80
Restoring and recovering your system.....	81
Creating a system restore	81
Restoring and recovery methods.....	81
Recovering using HP Recovery media	81
Changing the computer boot order	82
Using HP Sure Recover (select products only).....	82
8 Using HP PC Hardware Diagnostics	83
Using HP PC Hardware Diagnostics Windows (select products only).....	83
Using an HP PC Hardware Diagnostics Windows hardware failure ID code.....	83
Accessing HP PC Hardware Diagnostics Windows	83
Accessing HP PC Hardware Diagnostics Windows from HP Support Assistant.....	83
Accessing HP PC Hardware Diagnostics Windows from the Start menu (select products only).....	84
Downloading HP PC Hardware Diagnostics Windows.....	84
Downloading the latest HP PC Hardware Diagnostics Windows version from HP.....	84
Downloading the HP PC Hardware Diagnostics Windows from the Microsoft Store.....	84
Downloading HP Hardware Diagnostics Windows by product name or number (select products only)	85
Installing HP PC Hardware Diagnostics Windows.....	85
Using HP PC Hardware Diagnostics UEFI	85
Using an HP PC Hardware Diagnostics UEFI hardware failure ID code.....	85
Starting HP PC Hardware Diagnostics UEFI	85
Starting HP PC Hardware Diagnostics UEFI through HP Hotkey Support software (select products only).....	86
Downloading HP PC Hardware Diagnostics UEFI to a USB flash drive.....	86
Downloading the latest HP PC Hardware Diagnostics UEFI version.....	87
Downloading HP PC Hardware Diagnostics UEFI by product name or number (select products only)	87
Using Remote HP PC Hardware Diagnostics UEFI settings (select products only).....	87
Downloading Remote HP PC Hardware Diagnostics UEFI.....	87
Downloading the latest Remote HP PC Hardware Diagnostics UEFI version	87
Downloading Remote HP PC Hardware Diagnostics UEFI by product name or number	87
Customizing Remote HP PC Hardware Diagnostics UEFI settings.....	88
9 Specifications.....	89
Computer specifications.....	89
Display specifications.....	90

Solid-state drive specifications	90
10 Statement of memory volatility.....	92
Current BIOS steps	92
Nonvolatile memory usage	94
Questions and answers	95
Using HP Sure Start (select products only).....	96
11 Power cord set requirements.....	97
Requirements for all countries	97
Requirements for specific countries and regions	97
12 Recycling.....	100
Index.....	101

1 Product description

This table provides detailed product information.

Table 1-1 Product components and their descriptions

Category	Description
Product Name	HP Dragonfly 13.5 inch G4 Notebook PC
Processors	Intel® Core® i7-1365U 1.8 GHz processor (10 cores, 12 MB Intel Smart Cache, 15 W) Intel Core i7-1355U 1.7 GHz processor (10 cores, 12 MB Intel Smart Cache, 15 W) Intel Core i5-1345U 4.7 GHz processor (10 cores, 12 MB Intel Smart Cache, 15 W) Intel Core i5-1335U 1.3 GHz processor (10 cores, 12 MB Intel Smart Cache, 15 W)
Chipset	Intel integrated solder-on-circuit (SoC)
Display	34.3 cm (13.5 in), Widescreen Ultra Extended Graphics Array+ (WUXGA+) (1920 × 1200), liquid crystal display (LCD), ultrawide viewing angle (UWVA), bent display panel Brightview (BV), white light-emitting diode + low blue light (WLED + LBL), 100% sRGB, embedded DisplayPort™ 1.3 + panel self refresh (eDP 1.3 + PSR), touchscreen (TS) display panel with narrow bezel, ambient light sensor + adaptive color sensor (ALS + ACS), SureView Reflect, and CSR; typical brightness: 1000 nits BV, WLED + LBL, 100% sRGB, eDP 1.4 + PSR, TS display panel with narrow bezel, ALS + ACS, and CSR; typical brightness: 400 BV, WLED + LBL, 100 % sRGB, eDP 1.4 + PSR, non-TS display panel with narrow bezel, ALS + ACS; typical brightness: 400 BV, WLED + LBL, 100% sRGB, eDP 1.4 + PSR2, low power (LP), non-TS display panel with narrow bezel; typical brightness: 400 Antiglare (AG), WLED + LBL, 100 % sRGB, eDP 1.4 + PSR, TS display panel with narrow bezel, ALS + ACS, and CSR; typical brightness: 400 AG, WLED + LBL, 100 % sRGB, eDP 1.3 + PSR, non-TS display panel with narrow bezel, SureView, Reflect, ALS + ACS; typical brightness: 1000 AG, WLED + LBL, 100 % sRGB, eDP 1.3 + PSR, non-TS display panel with narrow bezel and G4 plus privacy filter; typical brightness: 1000
Memory	Integrated, onboard, small outline dual in-line memory modules (SODIMMs), 6400 Low-Power Double Data Rate5 (LPDDR5), 0.5 V, supporting 64 GB or 32 GB of system memory
eMMC	On-board embedded MultiMedia Controller (eMMC v5.0) 32 GB

Table 1-1 Product components and their descriptions (continued)

Category	Description
Primary storage	On-board embedded MultiMedia Controller (eMMC v5.0)
	Support for the following configurations:
	<ul style="list-style-type: none"> 2 TB, M.2 2280, Peripheral Component Interconnect Express (PCIe®)-4×4, ZTurbo solid-state drive with three-layer cell (TLC) 1 TB, 2280, PCIe-4×4, Non-Volatile Memory Express (NVMe®) solid-state drive with TLC 1 TB, M.2 2280, PCIe-4×4, self-encrypted (SED) solid-state drive with TLC 512 GB, M.2 2280, PCIe-4×4, NVMe, value solid-state drive 512 GB, 2280, PCIe-4×4, NVMe solid-state drive with TLC 512 GB, M.2 2280, PCIe-4×4, SED solid-state drive with TLC 256 GB, M.2 2280, PCIe-4×4, NVMe solid-state drive 256 GB, M.2 2280, PCIe-4×4, NVMe, SED solid-state drive with TLC
Audio and video	Audio brand: BANG and OLUFSEN
	Support for quad speakers
	Support for discrete amplifiers
	HP Wide Vision HD Camera: 5 MP, indicator LED, mobile industry processor interface (MIPI®), HD, wide field-of-view (NFOV), fixed, infrared (IR), integrated camera with eshutter
	Dual-array digital microphone with appropriate software: beam forming, echo cancellation, noise suppression
Wireless	Intel AX211 M.2 1216 Wi-Fi® 6E + Bluetooth® 5.3 vPro® WW wireless local area network (WLAN) module integrated onto system board
	Near field communication (NFC) Mirage WNC XRAV-1
	Wireless Wide Area Network (WWAN) module
	Intel 5000 5G WWAN module
	Intel XMM® 7560 R+ long-term evolution (LTE)-Advanced Pro (Cat 16) WWAN module
	WWAN module service providers: ATT and Verizon
Ports	Audio-out (headphone)/Audio-in (microphone) combo jack
	High-Definition Multimedia Interface (HDMI®) port
	SIM card slot (select products only)
	USB port with HP Sleep and Charge
	USB Type-C® power connector and Thunderbolt™ port with HP Sleep and Charge and DisplayPort output

Table 1-1 Product components and their descriptions (continued)

Category	Description
Keyboard/pointing devices	Keyboard: Backlit, spill-resistant, premium notebook PC keyboard with Clickpad and privacy features
	Touchpad
	Clickpad with image sensor
	Multitouch gestures enabled
	Precision touchpad support
	Support for Modern Trackpad Gestures
	Taps enabled as default
Power requirements	Battery:
	6 cell, 68 Whr, polymer, HP Long Life
	4 cell, 38 Whr, polymer, HP Long Life
	HP Fast Charge Technology
	Smart AC adapter:
	280 W AC adapter, Power Factor Correction (PFC), slim, 3 prong, 7.4 mm
	120 W HP Smart Adapter, PFC, slim, 7.4 mm
	120 W HP Smart Adapter, PFC, RC, 4.5 mm
	65 W AC adapter, nPFC, USB Type-C®, 1.8 m [6.0 ft]
	65 W AC adapter, nPFC, USB Type-C, slim, 3 prong)
	65 W AC adapter, USB Type-C
	65 W, nPFC, standard USB Type-C, straight barrel, 1.8m (6.0 ft)
	Power cord:
	C5, 1.0 m (3.3 ft), conventional with sticker
C5, 1.0 m (3.3 ft), premium with sticker	
Security	HP Combination Nano Cable Lock
	Integrated fingerprint reader
	Privacy camera shutter door
Sensors	Accelerometer + gyroscope
	Hall sensor (integrated)
	HP Sure Platform
	IC Accelerometer
	Infrared thermal sensor
	Time of Flight (TOF)

Table 1-1 Product components and their descriptions (continued)

Category	Description
Operating system	FreeDOS
	Windows® 11 Home
	Windows 11 Home Single Language
	Windows 11 Pro
	Windows 11 Pro (preinstalled with Windows 10 Pro Downgrade)
	Windows 11 Pro (Windows 11 Enterprise or Windows 10 Enterprise available with a Volume Licensing Agreement)
	Windows 11 Pro Education
Serviceability	End user replaceable part: AC adapter

2 Components

Your computer features top-rated components. This chapter provides details about your components, where they are located, and how they work.

Locating hardware

Use these instructions to find out what hardware is installed on your computer.

- Select the **Search** icon (select products only) in the taskbar, type `device manager` in the search box, and then select the **Device Manager** app.

A list displays all the devices installed on your computer.

For information about system hardware components and the system BIOS version number, press `fn+esc` (select products only).

Locating software

Use these instructions to find out what software is installed on your computer:

- Right-click the **Start** button, and then select **Apps and Features**.

Right

Use the illustration and table to identify the components on the right side of the computer.

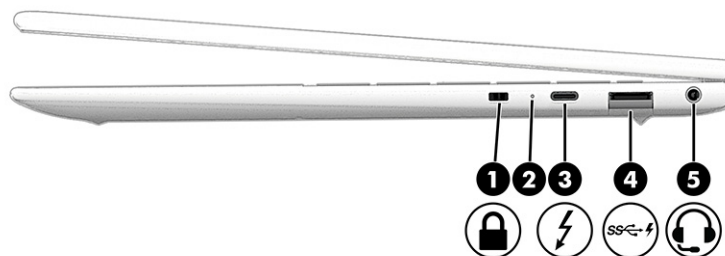

Table 2-1 Right-side components and their descriptions





Component	Description
<p>(1)  Security cable slot</p>	<p>Attaches an optional security cable to the computer.</p> <p>NOTE: The security cable is designed to act as a deterrent, but it might not prevent the computer from being mishandled or stolen.</p>
<p>(2) Battery light</p>	<p>When AC power is connected:</p> <ul style="list-style-type: none"> • White: The battery charge is greater than 90 percent. • Amber: The battery charge is from 0 to 90 percent. • Off: The battery is not charging. <p>When AC power is disconnected (battery not charging):</p> <ul style="list-style-type: none"> • Blinking amber: The battery has reached a low battery level. When the battery has reached a critical battery level, the battery light begins blinking rapidly. • Off: The battery is not charging.
<p>(3)  USB Type-C® power connector and Thunderbolt™ port with HP Sleep and Charge and DisplayPort™ output</p>	<p>Connects an AC adapter that has a USB Type-C connector, supplying power to the computer and, if needed, charging the computer battery.</p> <p>- and -</p> <p>Connects a USB device, provides high-speed data transfer, and charges small devices (such as a smartphone), even when the computer is off.</p> <p>NOTE: Use a standard USB Type-C charging cable or cable adapter (purchased separately) when charging a small external device.</p> <p>- and -</p> <p>Connects a display device that has a USB Type-C connector, providing DisplayPort output.</p> <p>NOTE: Your computer might also support a Thunderbolt docking station.</p>
<p>(4)  USB SuperSpeed port with HP Sleep and Charge</p>	<p>Connects a USB device, provides high-speed data transfer, and charges small devices (such as a smartphone), even when the computer is off.</p> <p>NOTE: Use a standard USB Type-A charging cable or cable adapter (purchased separately) when charging a small external device.</p>

Table 2-1 Right-side components and their descriptions (continued)

Component	Description
(5)  Audio-out (headphone)/Audio-in (microphone) combo jack	<p>Connects optional powered stereo speakers, headphones, earbuds, a headset, or a television audio cable. This jack does not support optional standalone microphones.</p> <p>WARNING! To reduce the risk of personal injury, adjust the volume before putting on headphones, earbuds, or a headset. For additional safety information, see the <i>Regulatory, Safety, and Environmental Notices</i>.</p> <p>To access this guide:</p> <ul style="list-style-type: none"> Select the Search icon in the taskbar, type HP Documentation in the search box, and then select HP Documentation. <p>NOTE: When a device is connected to the jack, the computer speakers are disabled.</p>

Left

Use the illustration and table to identify the components on the left side of the computer.

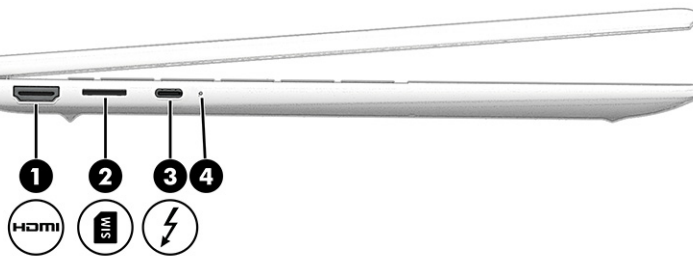

Table 2-2 Left-side components and their descriptions



Component	Description
(1)  HDMI® port	Connects an optional video or audio device, such as a high-definition television, any compatible digital or audio component, or a high-speed High Definition Multimedia Interface® (HDMI) device.
(2)  SIM card slot (select products only)	Supports a wireless subscriber identity module (SIM) card.

Table 2-2 Left-side components and their descriptions (continued)

Component	Description
<p>(3)  USB Type-C power connector and Thunderbolt port with HP Sleep and Charge and DisplayPort output</p>	<p>Connects an AC adapter that has a USB Type-C connector, supplying power to the computer and, if needed, charging the computer battery.</p> <p>- and -</p> <p>Connects a USB device, provides high-speed data transfer, and charges small devices (such as a smartphone), even when the computer is off.</p> <p>NOTE: Use a standard USB Type-C charging cable or cable adapter (purchased separately) when charging a small external device.</p> <p>- and -</p> <p>Connects a display device that has a USB Type-C connector, providing DisplayPort output.</p> <p>NOTE: Your computer might also support a Thunderbolt docking station.</p>
<p>(4) Battery light</p>	<p>When AC power is connected:</p> <ul style="list-style-type: none"> • White: The battery charge is greater than 90 percent. • Amber: The battery charge is from 0 to 90 percent. • Off: The battery is not charging. <p>When AC power is disconnected (battery not charging):</p> <ul style="list-style-type: none"> • Blinking amber: The battery has reached a low battery level. When the battery has reached a critical battery level, the battery light begins blinking rapidly. • Off: The battery is not charging.

Display

Use the illustration and table to identify the display components.

Auto Lock and Awake

Auto Lock and Awake monitors your presence in front of the computer to save power and add security.

When you step away from the computer, the proximity sensor puts the computer into the Sleep state. When you return to the computer, the sensor recognizes you and wakes the computer automatically. Auto Lock and Awake is turned on by default.

To access Auto Lock and Awake:

1. Select the **Start** button, select **Settings**, select **System**, and then select **Power & battery**.
2. Select **Screen and sleep**, and then follow the on-screen instructions.

Low blue light mode (select products only)

Your computer display is shipped from the factory in low blue light mode for improved eye comfort and safety. Also, blue light mode automatically adjusts blue light emissions when you are using the computer at night or for reading.

⚠ WARNING! To reduce the risk of serious injury, read the *Safety & Comfort Guide*. It describes proper workstation setup and proper posture, health, and work habits for computer users. The *Safety & Comfort Guide* also provides important electrical and mechanical safety information. The *Safety & Comfort Guide* is available on the web at <http://www.hp.com/ergo>.

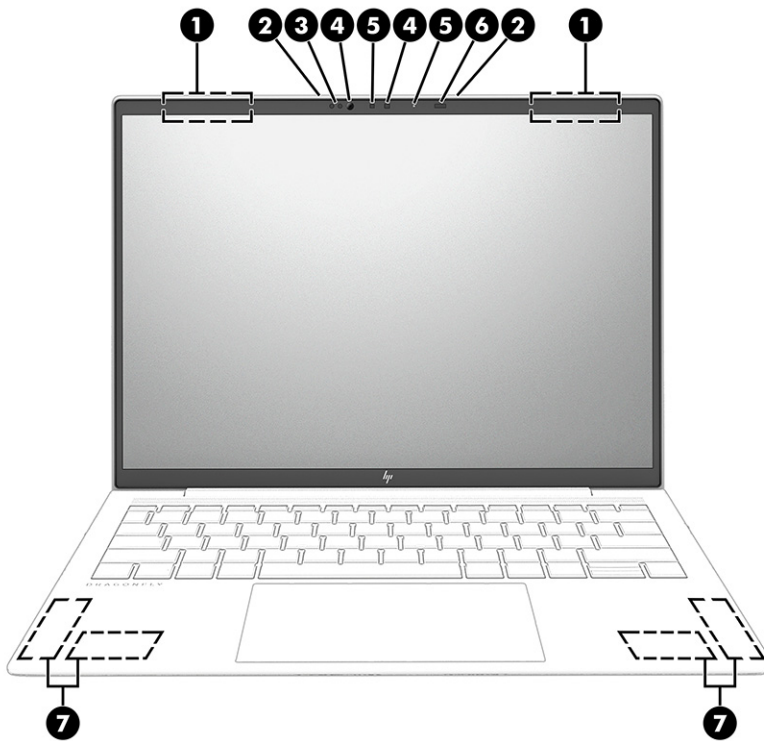

Table 2-3 Display components and their descriptions

Component	Description
(1) WLAN antennas* (2)	Send and receive wireless signals to communicate with wireless local area networks (WLANs).
(2) Internal microphones (2)	Record sound.
(3) Ambient light and color sensors	Adjust the brightness of the display, depending on the ambient light, and manages and controls the color temperature. Color temperature enables you to measure and adjust the warmth or coolness of the light source. NOTE: Do not cover the sensor. The display brightness adjusts if the sensor notices light change.
(4) Camera lights (2)	On: One or more cameras are in use.

Table 2-3 Display components and their descriptions (continued)

Component	Description
(5) Cameras (2)	Allow you to video chat, record video, and record still images. Some cameras also allow a facial recognition logon to Windows, instead of a password logon. NOTE: Camera functions vary depending on the camera hardware and software installed on your product.
(6) User-proximity sensor	Uses the Auto Lock and Awake feature to monitor your presence in front of the computer to save power and add security. When you step away from the computer, the proximity sensor puts the computer into the Sleep state. When you return to the computer, the sensor recognizes you and wakes the computer automatically. Auto Lock and Awake is turned on by default.
(7) WWAN antennas* (4) (select products only)	Send and receive wireless signals to communicate with wireless wide area networks (WWANs).

*The antennas are not visible from the outside of the computer. For optimal transmission, keep the areas immediately around the antennas free from obstructions.

For wireless regulatory notices, see the section of the *Regulatory, Safety, and Environmental Notices* that applies to your country or region.

To access this guide:

- Select the **Search** icon in the taskbar, type `HP Documentation` in the search box, and then select **HP Documentation**.

Keyboard area

Keyboards can vary by language.



NOTE: The keyboard, including the function keys and power key (select products only), is disabled in stand, tent, and tablet modes. To enable the keyboard, including the power key, change to the clamshell mode.

Touchpad

The touchpad settings and components are described here.

Touchpad settings

You learn how to adjust the touchpad settings and components here.

Adjusting touchpad settings

Use these steps to adjust touchpad settings and gestures.

1. Select the **Search** icon (select products only) in the taskbar, type `touchpad settings` in the search box, and then press enter.
2. Choose a setting.

Turning on the touchpad

Follow these steps to turn on the touchpad.

1. Select the **Search** icon (select products only) in the taskbar, type `touchpad settings` in the search box, and then press `enter`.
2. Using an external mouse, click the **Touchpad** button.

If you are not using an external mouse, press the `Tab` key repeatedly until the pointer rests on the **touchpad** button. Then press the `spacebar` to select the button.

Touchpad components

Use the illustration and table to identify the touchpad components.

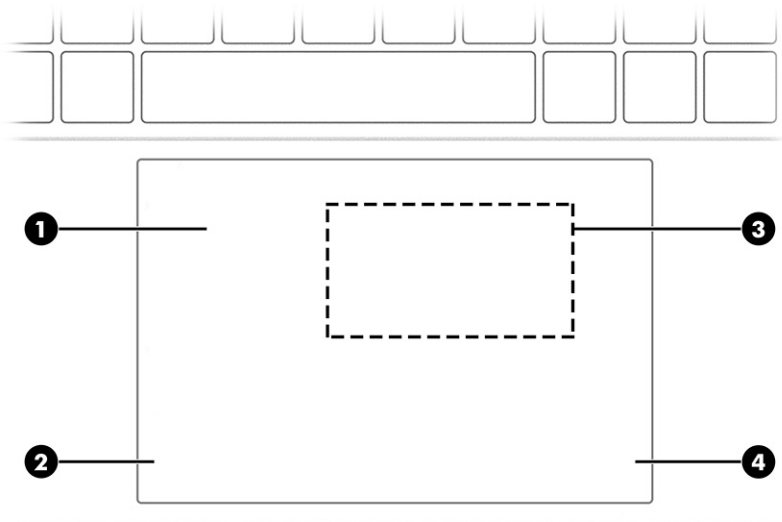

Table 2-4 Touchpad components and their descriptions

Component	Description
(1) Touchpad zone	Reads your finger gestures to move the pointer or activate items on the screen.
(2) Left touchpad button	Functions like the left button on an external mouse.
(3) Near Field Communications (NFC) tapping area and antenna (select products only)	Allows you to wirelessly share information when you tap it with an NFC-enabled device.
(4) Right touchpad button	Functions like the right button on an external mouse.

Lights

Use the illustration and table to identify the lights on the computer.

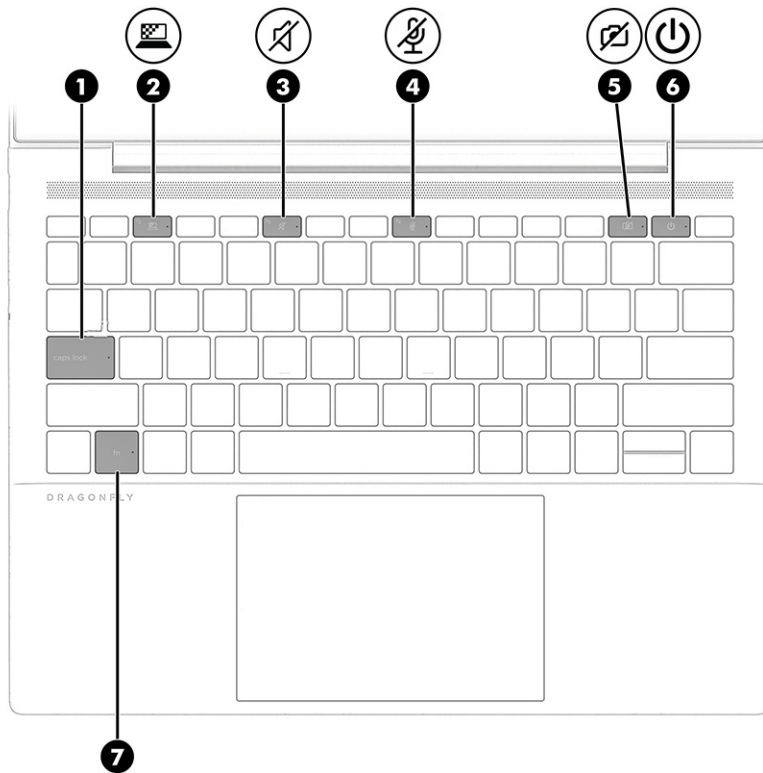







Table 2-5 Lights and their descriptions

Component	Description
(1) Caps lock light	On: Caps lock is on, which switches the key input to all capital letters.
(2)  Privacy key light	On: Privacy screen is on, which helps prevent side-angle viewing.
(3)  Mute light	<ul style="list-style-type: none"> On: Computer sound is off. Off: Computer sound is on.
(4)  Microphone mute light	<ul style="list-style-type: none"> On: Microphone is off. Off: Microphone is on.
(5)  Camera privacy light	<ul style="list-style-type: none"> On: The camera is off. Off: The camera is on.
(6)  Power light	<ul style="list-style-type: none"> On: The computer is on. Blinking (select products only): The computer is in the Sleep state, a power-saving state. The computer shuts off power to the display and other unnecessary components. Off: Depending on your computer model, the computer is off, in Hibernation, or in Sleep. Hibernation is the power-saving state that uses the least amount of power.
(7) Fn lock light	On: The fn key is locked.

Button, speakers, and fingerprint reader

Fingerprint readers can be located on the touchpad, on a side panel of the computer, or on the top cover below the keyboard.

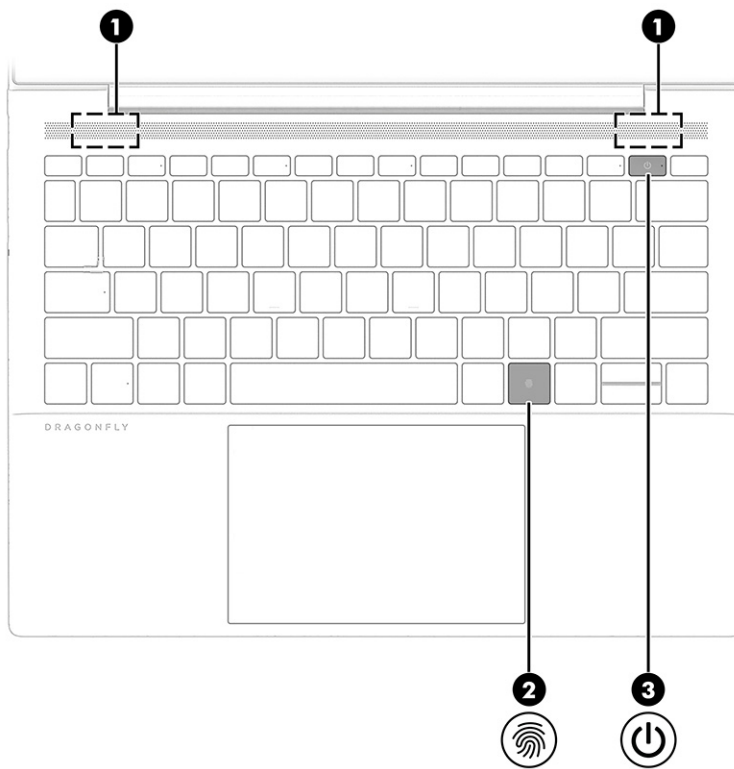

Table 2-6 Button, speakers, and fingerprint reader and their descriptions



Component	Description
(1) Speakers (2)	Produce sound.
(2)  Fingerprint reader	Allows a fingerprint logon to Windows, instead of a password logon. <ul style="list-style-type: none">■ Touch your finger to the fingerprint reader. <p>IMPORTANT: To prevent fingerprint logon issues, make sure when you register your fingerprint that all sides of your finger are registered by the fingerprint reader.</p>

Table 2-6 Button, speakers, and fingerprint reader and their descriptions (continued)

Component	Description
<p>(3)  Power button</p>	<ul style="list-style-type: none"> When the computer is off, press the button briefly to turn on the computer. When the computer is on, press the button briefly to initiate Sleep. When the computer is in the Sleep state, press the button briefly to exit Sleep (select products only). When the computer is in Hibernation, press the button briefly to exit Hibernation. <p>IMPORTANT: Pressing and holding down the power button results in the loss of unsaved information.</p> <p>If the computer has stopped responding and shutdown procedures are ineffective, press and hold the power button for at least 4 seconds to turn off the computer.</p> <p>To learn more about your power settings, use the Power icon.</p> <ul style="list-style-type: none"> Right-click the Power icon , and then select Power and sleep settings.

Special keys

Use the illustration and table to identify the special keys.

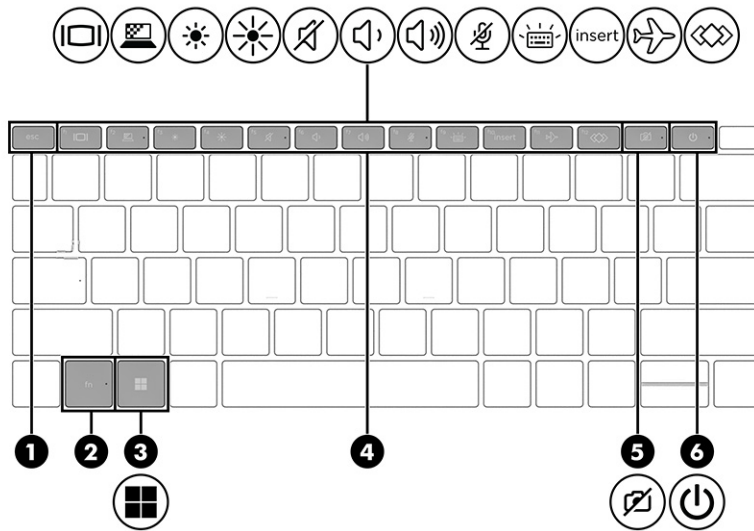





Table 2-7 Special keys and their descriptions

Component	Description
(1) esc key	Displays system information when pressed in combination with the fn key.

Table 2-7 Special keys and their descriptions (continued)

Component	Description
(2) fn key	Executes frequently used system functions when pressed in combination with another key. Such key combinations are called <i>hot keys</i> .
(3)  Windows key	Opens the Start menu. NOTE: Pressing the Windows key again closes the Start menu.
(4) Action keys	Execute frequently used system functions.
(5)  Camera privacy key	Turns the camera off and on.
(6)  Power button	<ul style="list-style-type: none"> • When the computer is off, press the button briefly to turn on the computer. • When the computer is on, press the button briefly to initiate Sleep. • When the computer is in the Sleep state, press the button briefly to exit Sleep (select products only). • When the computer is in Hibernation, press the button briefly to exit Hibernation. <p>IMPORTANT: Pressing and holding down the power button results in the loss of unsaved information.</p> <p>If the computer has stopped responding and shutdown procedures are ineffective, press and hold the power button for at least 4 seconds to turn off the computer.</p> <p>To learn more about your power settings, use the Power icon.</p> <ul style="list-style-type: none"> • Right-click the Power icon  and then select Power and sleep settings.

Bottom

Use the illustration and table to identify the bottom components.

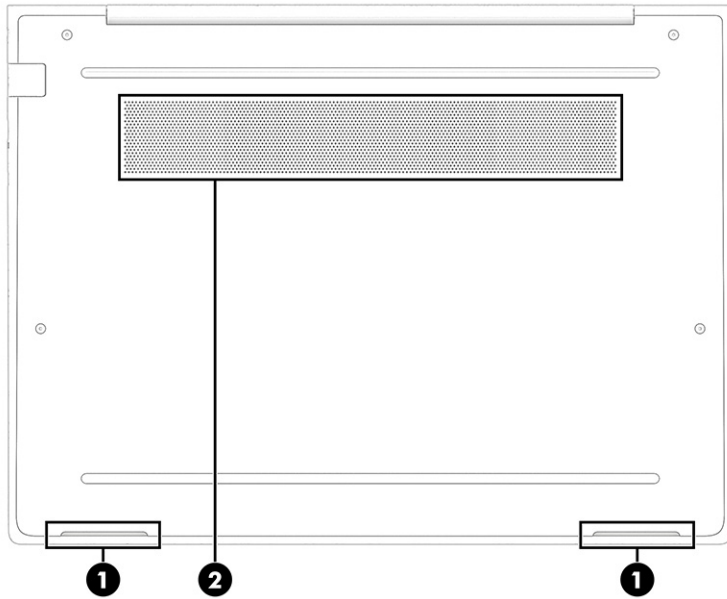

Table 2-8 Bottom components and their descriptions

Component	Description
(1) Speakers (2)	Produce sound.
(2) Vent	Enables airflow to cool internal components.

NOTE: The computer fan starts up automatically to cool internal components and prevent overheating. It is normal for the internal fan to cycle on and off during routine operation.

Using a SIM card (select products only)

Use these instructions to insert a SIM card.

IMPORTANT: You can damage the SIM card if you insert the wrong size card or insert it or the SIM card tray in the wrong direction. The card might also become stuck in the slot. Do not use SIM card adapters. To prevent damage to the SIM card or connectors, use minimal force when inserting or removing a SIM card.

Determining the correct SIM card size for your computer

Before purchasing a SIM card, follow these instructions to determine the correct SIM card size for your computer.

1. Go to <http://www.hp.com/support>, and then search for your computer by product name or number.
2. Select **Product Information**.
3. Refer to the listed options to determine which card to purchase.

Inserting a nano SIM card

To insert a nano SIM card, follow these steps.

1. Turn off the computer by using the **Shut down** command.
2. Position the computer display-side up on a flat surface.
3. Press in gently on the SIM card access tray to disengage the SIM lock, and the tray will pop out of the slot (**1**).
4. Remove the tray (**2**) from the computer and insert the card (**3**).
5. Replace the tray in the computer. Press in gently on the tray (**4**) until it is firmly seated.

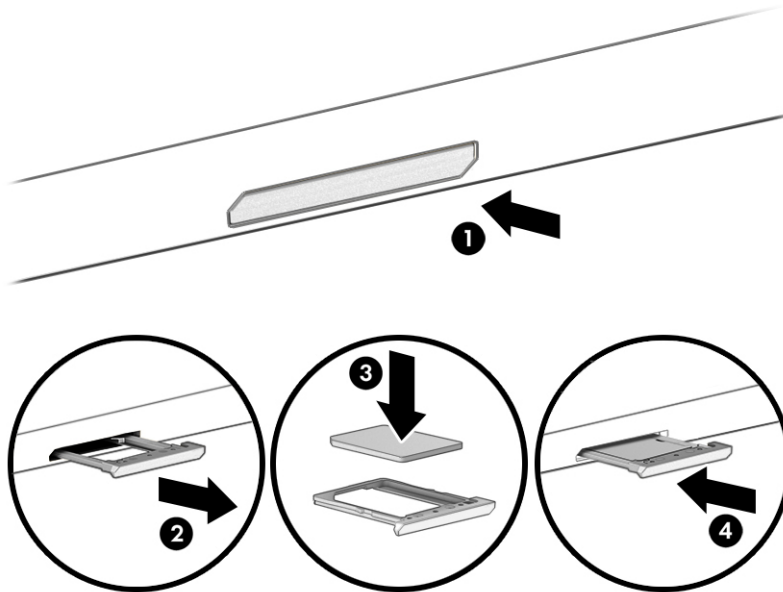

To remove the SIM card, press in gently on the SIM card access tray to disengage the SIM lock, and the tray will pop out of the slot. Remove the SIM card. Replace the tray in the computer and press in gently on the tray until it is firmly seated.

Labels

The labels affixed to the computer provide information that you might need when you troubleshoot system problems or travel internationally with the computer. Labels can be in paper form or imprinted on the product.

 **IMPORTANT:** Check the following locations for the labels described in this section: the bottom of the computer, inside the battery bay, under the service door, on the back of the display, or on the bottom of a tablet kickstand.

- Service label—Provides important information to identify your computer. When contacting support, you may be asked for the serial number, the product number, or the model number. Locate this information before you contact support.

Your service label will resemble one of the following examples. Refer to the illustration that most closely matches the service label on your computer.

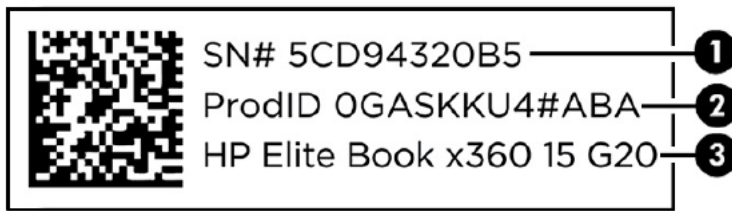

Table 2-9 Service label components and their descriptions

Component	
(1)	Serial number
(2)	Product ID
(3)	HP product name

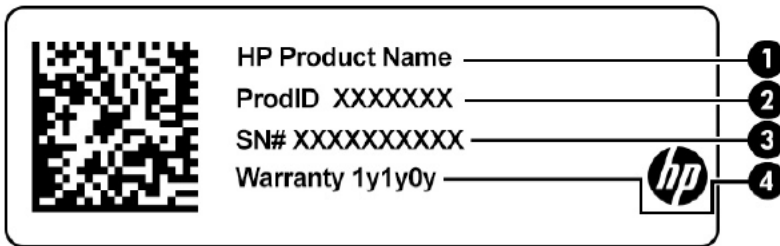

Table 2-10 Service label components and their descriptions

Component	
(1)	HP product name
(2)	Product ID
(3)	Serial number
(4)	Warranty period

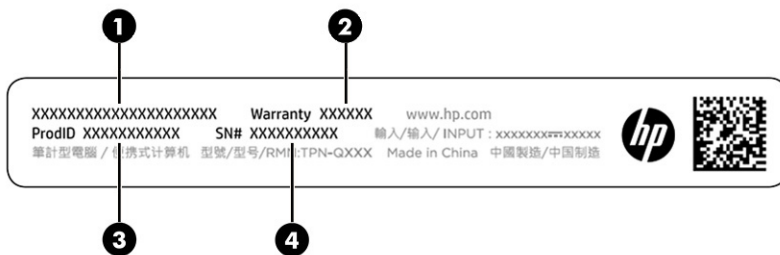

Table 2-11 Service label components and their descriptions

Component	
(1)	HP product name
(2)	Warranty period

Table 2-11 Service label components and their descriptions (continued)

Component	
(3)	Product ID
(4)	Serial number

- Regulatory labels—Provide regulatory information about the computer.
- Wireless certification labels—Provide information about optional wireless devices and the approval markings for the countries or regions in which the devices have been approved for use.

3 Illustrated parts catalog

Use this table to determine the spare parts that are available for the computer.

Computer major components

To identify the computer major components, use this illustration and table.

 **NOTE:** HP continually improves and changes product parts. For complete and current information about supported parts for your computer, go to <http://partsurfer.hp.com>, select your country or region, and then follow the on-screen instructions.

 **NOTE:** Details about your computer, including model, serial number, product key, and length of warranty, are on the service tag at the bottom of your computer.

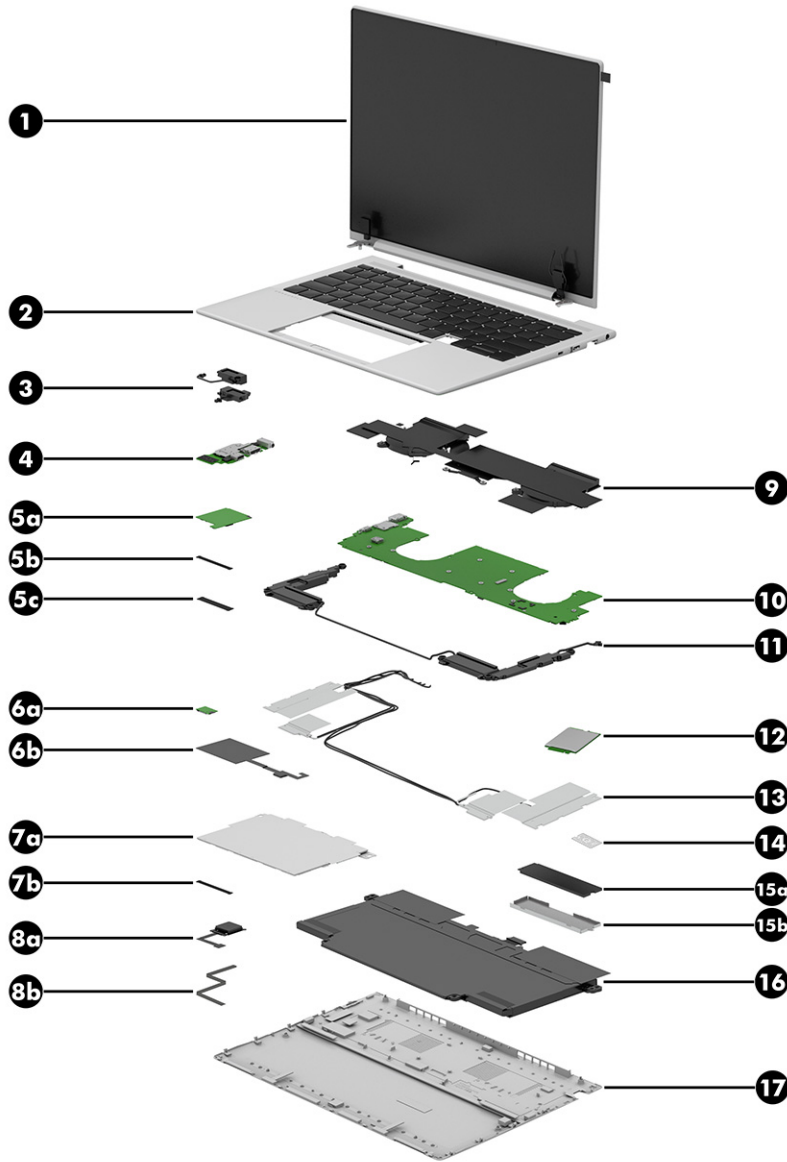

Table 3-1 Computer major component descriptions and part numbers

Item	Component	Spare part number
(1)	Display assembly (all display assembly spare part kits include a webcam)	
	In natural silver finish:	
	34.3 cm (13.5 in), LCD, WUXGA (1920 × 1200), nantiglare, UWVA, TOP display panel; typical brightness: 1000 nits	N51331-001
	34.3 cm (13.5 in), LCD, WUXGA (1920 × 1200), antiglare, UWVA, TOP display panel; typical brightness: 400 nits	N51330-001
	34.3 cm (13.5 in), LCD, WUXGA (1920 × 1200), nantiglare, UWVA, TOP display panel; typical brightness: 400 nits	N51333-001
	34.3 cm (13.5 in), LCD, UHD, WUXGA (3000 × 2000), brightview, OLED, UWVA, non-TOP display panel; typical brightness: 400 nits	N51334-001

Table 3-1 Computer major component descriptions and part numbers (continued)

Item	Component	Spare part number
	34.3 cm (13.5 in), LCD, WUXGA (1920 × 1200), UWVA, non-TOP display panel with privacy filter; typical brightness: 1000 nits	N51329-001
	34.3 cm (13.5 in), LCD, WUXGA (1920 × 1200), UWVA, non-TOP display panel; typical brightness: 400 nits	N51332-001
	In slate blue finish:	
	34.3 cm (13.5 in), LCD, WUXGA (1920 × 1200), nantiglare, UWVA, TOP display panel; typical brightness: 1000 nits	N51337-001
	34.3 cm (13.5 in), LCD, WUXGA (1920 × 1200), antiglare, UWVA, TOP display panel; typical brightness: 400 nits	N51336-001
	34.3 cm (13.5 in), LCD, WUXGA (1920 × 1200), nantiglare, UWVA, TOP display panel; typical brightness: 400 nits	N51339-001
	34.3 cm (13.5 in), LCD, WUXGA (1920 × 1200), UWVA, non-TOP display panel with privacy filter; typical brightness: 1000 nits	N51335-001
	34.3 cm (13.5 in), LCD, WUXGA (1920 × 1200), UWVA, non-TOP display panel; typical brightness: 400 nits	N51338-001
(2)	Top cover with keyboard in natural silver finish, backlit and spill-resistant for use on computer models equipped with WWAN capability and a display assembly with privacy filter (includes backlight cable and keyboard cable):	
	For use in Belgium	N08586-A41
	For use in Brazil	N08586-201
	For use in Bulgaria	N08586-261
	For use in the Czech Republic and Slovakia	N08586-FL1
	For use in Denmark	N08586-081
	For use in Denmark, Finland, and Norway	N08586-DH1
	For use in France	N08586-051
	For use in French Canada	N08586-DB1
	For use in Germany	N08586-041
	For use in Greece	N08586-151
	For use in Hungary	N08586-211
	For use in Iceland	N08586-DD1
	For use in India	N08586-D61
	For use in Israel	N08586-BB1
	For use in Italy	N08586-061
	For use in Japan	N08586-291
	For use in Kazakhstan	N08586-DF1
	For use in Latin America	N08586-161
	For use in the Netherlands	N08586-B31
	For use in North Africa	N08586-FP1
	For use in Norway	N08586-091

Table 3-1 Computer major component descriptions and part numbers (continued)

Item	Component	Spare part number
	For use in Portugal	N08586-131
	For use in Romania	N08586-261
	For use in Russia	N08586-251
	For use in Saudi Arabia	N08586-171
	For use in Slovenia	N08586-BA1
	For use in South Korea	N08586-AD1
	For use in Spain	N08586-071
	For use in Sweden and Finland	N08586-B71
	For use in Switzerland	N08586-BG1
	For use in Taiwan	N08586-AB1
	For use in Thailand	N08586-281
	For use in Turkey	N08586-141
	For use in Turkey-F	N08586-541
	For use in Ukraine	N08586-BD1
	For use in the United Kingdom	N08586-031
	For use in the United States	N08586-001
(2)	Top cover with keyboard in natural silver finish, backlit and spill-resistant for use on computer models equipped with a display assembly with privacy filter (includes backlight cable and keyboard cable):	
	For use in Belgium	N08584-A41
	For use in Brazil	N08584-201
	For use in Bulgaria	N08584-261
	For use in the Czech Republic and Slovakia	N08584-FL1
	For use in Denmark	N08584-081
	For use in Denmark, Finland, and Norway	N08584-DH1
	For use in France	N08584-051
	For use in French Canada	N08584-DB1
	For use in Germany	N08584-041
	For use in Greece	N08584-151
	For use in Hungary	N08584-211
	For use in Iceland	N08584-DD1
	For use in India	N08584-D61
	For use in Israel	N08584-BB1
	For use in Italy	N08584-061
	For use in Japan	N08584-291
	For use in Kazakhstan	N08584-DF1

Table 3-1 Computer major component descriptions and part numbers (continued)

Item	Component	Spare part number
	For use in Latin America	N08584-161
	For use in the Netherlands	N08584-B31
	For use in North Africa	N08584-FP1
	For use in Norway	N08584-091
	For use in Portugal	N08584-131
	For use in Romania	N08584-261
	For use in Russia	N08584-251
	For use in Saudi Arabia	N08584-171
	For use in Slovenia	N08584-BA1
	For use in South Korea	N08584-AD1
	For use in Spain	N08584-071
	For use in Sweden and Finland	N08584-B71
	For use in Switzerland	N08584-BG1
	For use in Taiwan	N08584-AB1
	For use in Thailand	N08584-281
	For use in Turkey	N08584-141
	For use in Ukraine	N08584-BD1
	For use in the United Kingdom	N08584-031
	For use in the United States	N08584-001
(2)	Top cover with keyboard in natural silver finish, backlit and spill-resistant for use on computer models equipped with WWAN capability (includes backlight cable and keyboard cable):	
	For use in Belgium	N08585-A41
	For use in Brazil	N08585-201
	For use in Bulgaria	N08585-261
	For use in the Czech Republic and Slovakia	N08585-FL1
	For use in Denmark	N08585-081
	For use in Denmark, Finland, and Norway	N08585-DH1
	For use in France	N08585-051
	For use in French Canada	N08585-DB1
	For use in Germany	N08585-041
	For use in Greece	N08585-151
	For use in Hungary	N08585-211
	For use in Iceland	N08585-DD1
	For use in India	N08585-D61
	For use in Israel	N08585-BB1

Table 3-1 Computer major component descriptions and part numbers (continued)

Item	Component	Spare part number
	For use in Italy	N08585-061
	For use in Japan	N08585-291
	For use in Kazakhstan	N08585-DF1
	For use in Latin America	N08585-161
	For use in the Netherlands	N08585-B31
	For use in North Africa	N08585-FP1
	For use in Norway	N08585-091
	For use in Portugal	N08585-131
	For use in Romania	N08585-261
	For use in Russia	N08585-251
	For use in Saudi Arabia	N08585-171
	For use in Slovenia	N08585-BA1
	For use in South Korea	N08585-AD1
	For use in Spain	N08585-071
	For use in Sweden and Finland	N08585-B71
	For use in Switzerland	N08585-BG1
	For use in Taiwan	N08585-AB1
	For use in Thailand	N08585-281
	For use in Turkey	N08585-141
	For use in Turkey-F	N08585-541
	For use in Ukraine	N08585-BD1
	For use in the United Kingdom	N08585-031
	For use in the United States	N08585-001
(2)	Top cover with keyboard in natural silver finish, backlit and spill-resistant (includes backlight cable and keyboard cable):	
	For use in Belgium	N08583-A41
	For use in Brazil	N08583-201
	For use in Bulgaria	N08583-261
	For use in the Czech Republic and Slovakia	N08583-FL1
	For use in Denmark	N08583-081
	For use in Denmark, Finland, and Norway	N08583-DH1
	For use in France	N08583-051
	For use in French Canada	N08583-DB1
	For use in Germany	N08583-041
	For use in Greece	N08583-151

Table 3-1 Computer major component descriptions and part numbers (continued)

Item	Component	Spare part number
	For use in Hungary	N08583-211
	For use in Iceland	N08583-DD1
	For use in India	N08583-D61
	For use in Israel	N08583-BB1
	For use in Italy	N08583-061
	For use in Japan	N08583-291
	For use in Kazakhstan	N08583-DF1
	For use in Latin America	N08583-161
	For use in the Netherlands	N08583-B31
	For use in North Africa	N08583-FP1
	For use in Norway	N08583-091
	For use in Portugal	N08583-131
	For use in Romania	N08583-261
	For use in Russia	N08583-251
	For use in Saudi Arabia	N08583-171
	For use in Slovenia	N08583-BA1
	For use in South Korea	N08583-AD1
	For use in Spain	N08583-071
	For use in Sweden and Finland	N08583-B71
	For use in Switzerland	N08583-BG1
	For use in Taiwan	N08583-AB1
	For use in Thailand	N08583-281
	For use in Turkey	N08583-141
	For use in Turkey-F	N08583-541
	For use in Ukraine	N08583-BD1
	For use in the United Kingdom	N08583-031
	For use in the United States	N08583-001
(2)	Top cover with keyboard in slate blue finish, backlit and spill-resistant for use on computer models equipped with WWAN capability and a display assembly with privacy filter (includes backlight cable and keyboard cable):	
	For use in Belgium	N08582-A41
	For use in Brazil	N08582-201
	For use in Bulgaria	N08582-261
	For use in the Czech Republic and Slovakia	N08582-FL1
	For use in Denmark	N08582-081
	For use in Denmark, Finland, and Norway	N08582-DH1

Table 3-1 Computer major component descriptions and part numbers (continued)

Item	Component	Spare part number
	For use in France	N08582-051
	For use in French Canada	N08582-DB1
	For use in Germany	N08582-041
	For use in Greece	N08582-151
	For use in Hungary	N08582-211
	For use in Iceland	N08582-DD1
	For use in India	N08582-D61
	For use in Israel	N08582-BB1
	For use in Italy	N08582-061
	For use in Japan	N08582-291
	For use in Kazakhstan	N08582-DF1
	For use in Latin America	N08582-161
	For use in the Netherlands	N08582-B31
	For use in North Africa	N08582-FP1
	For use in Norway	N08582-091
	For use in Portugal	N08582-131
	For use in Romania	N08582-261
	For use in Russia	N08582-251
	For use in Saudi Arabia	N08582-171
	For use in Slovenia	N08582-BA1
	For use in South Korea	N08582-AD1
	For use in Spain	N08582-071
	For use in Sweden and Finland	N08582-B71
	For use in Switzerland	N08582-BG1
	For use in Taiwan	N08582-AB1
	For use in Thailand	N08582-281
	For use in Turkey	N08582-141
	For use in Turkey-F	N08582-541
	For use in Ukraine	N08582-BD1
	For use in the United Kingdom	N08582-031
	For use in the United States	N08582-001
(2)	Top cover with keyboard in slate blue finish, backlit and spill-resistant for use on computer models equipped with a display assembly with privacy filter (includes backlight cable and keyboard cable):	
	For use in Belgium	N08580-A41
	For use in Brazil	N08580-201

Table 3-1 Computer major component descriptions and part numbers (continued)

Item	Component	Spare part number
	For use in Bulgaria	N08580-261
	For use in the Czech Republic and Slovakia	N08580-FL1
	For use in Denmark	N08580-081
	For use in Denmark, Finland, and Norway	N08580-DH1
	For use in France	N08580-051
	For use in French Canada	N08580-DB1
	For use in Germany	N08580-041
	For use in Greece	N08580-151
	For use in Hungary	N08580-211
	For use in Iceland	N08580-DD1
	For use in India	N08580-D61
	For use in Israel	N08580-BB1
	For use in Italy	N08580-061
	For use in Japan	N08580-291
	For use in Kazakhstan	N08580-DF1
	For use in Latin America	N08580-161
	For use in the Netherlands	N08580-B31
	For use in North Africa	N08580-FP1
	For use in Norway	N08580-091
	For use in Portugal	N08580-131
	For use in Romania	N08580-261
	For use in Russia	N08580-251
	For use in Saudi Arabia	N08580-171
	For use in Slovenia	N08580-BA1
	For use in South Korea	N08580-AD1
	For use in Spain	N08580-071
	For use in Sweden and Finland	N08580-B71
	For use in Switzerland	N08580-BG1
	For use in Taiwan	N08580-AB1
	For use in Thailand	N08580-281
	For use in Turkey	N08580-141
	For use in Ukraine	N08580-BD1
	For use in the United Kingdom	N08580-031
	For use in the United States	N08580-001

Table 3-1 Computer major component descriptions and part numbers (continued)

Item	Component	Spare part number
(2)	Top cover with keyboard in slate blue finish, backlit and spill-resistant for use on computer models equipped with WWAN capability (includes backlight cable and keyboard cable):	
	For use in Belgium	N08581-A41
	For use in Brazil	N08581-201
	For use in Bulgaria	N08581-261
	For use in the Czech Republic and Slovakia	N08581-FL1
	For use in Denmark	N08581-081
	For use in Denmark, Finland, and Norway	N08581-DH1
	For use in France	N08581-051
	For use in French Canada	N08581-DB1
	For use in Germany	N08581-041
	For use in Greece	N08581-151
	For use in Hungary	N08581-211
	For use in Iceland	N08581-DD1
	For use in India	N08581-D61
	For use in Israel	N08581-BB1
	For use in Italy	N08581-061
	For use in Japan	N08581-291
	For use in Kazakhstan	N08581-DF1
	For use in Latin America	N08581-161
	For use in the Netherlands	N08581-B31
	For use in North Africa	N08581-FP1
	For use in Norway	N08581-091
	For use in Portugal	N08581-131
	For use in Romania	N08581-261
	For use in Russia	N08581-251
	For use in Saudi Arabia	N08581-171
	For use in Slovenia	N08581-BA1
	For use in South Korea	N08581-AD1
	For use in Spain	N08581-071
	For use in Sweden and Finland	N08581-B71
	For use in Switzerland	N08581-BG1
	For use in Taiwan	N08581-AB1
	For use in Thailand	N08581-281
	For use in Turkey	N08581-141

Table 3-1 Computer major component descriptions and part numbers (continued)

Item	Component	Spare part number
	For use in Turkey-F	N08581-541
	For use in Ukraine	N08581-BD1
	For use in the United Kingdom	N08581-031
	For use in the United States	N08581-001
(2)	Top cover with keyboard in slate blue finish, backlit and spill-resistant (includes backlight cable and keyboard cable):	
	For use in Belgium	N08579-A41
	For use in Brazil	N08579-201
	For use in Bulgaria	N08579-261
	For use in the Czech Republic and Slovakia	N08579-FL1
	For use in Denmark	N08579-081
	For use in Denmark, Finland, and Norway	N08579-DH1
	For use in France	N08579-051
	For use in French Canada	N08579-DB1
	For use in Germany	N08579-041
	For use in Greece	N08579-151
	For use in Hungary	N08579-211
	For use in Iceland	N08579-DD1
	For use in India	N08579-D61
	For use in Israel	N08579-BB1
	For use in Italy	N08579-061
	For use in Japan	N08579-291
	For use in Kazakhstan	N08579-DF1
	For use in Latin America	N08579-161
	For use in the Netherlands	N08579-B31
	For use in North Africa	N08579-FP1
	For use in Norway	N08579-091
	For use in Portugal	N08579-131
	For use in Romania	N08579-261
	For use in Russia	N08579-251
	For use in Saudi Arabia	N08579-171
	For use in Slovenia	N08579-BA1
	For use in South Korea	N08579-AD1
	For use in Spain	N08579-071
	For use in Sweden and Finland	N08579-B71

Table 3-1 Computer major component descriptions and part numbers (continued)

Item	Component	Spare part number
	For use in Switzerland	N08579-BG1
	For use in Taiwan	N08579-AB1
	For use in Thailand	N08579-281
	For use in Turkey	N08579-141
	For use in Turkey-F	N08579-541
	For use in Ukraine	N08579-BD1
	For use in the United Kingdom	N08579-031
	For use in the United States	N08579-001
(3)	Rear speakers (included in the Speaker Kit; includes left and right rear speakers and cables)	N08563-001
(4)	Connector board (includes USB port and microSD slot)	
	In natural silver finish	N11564-001
	In slate blue finish	N16841-001
(5a)	Transfer board	N11563-001
(5b) and (5c)	Transfer board cables: The transfer board cables are included in the Cable Kit, spare part number tbd-001.	
(6a)	NFC module	M08706-001
	NOTE: The NFC module spare part kit does not include the NFC module cable. The NFC module cable is included in the Cable Kit, spare part number tbd-001.	
(6b)	NFC module antenna: The NFC module antenna is included in the Cable Kit, spare part number tbd-001.	
(7a)	Touchpad:	
	NOTE: The touchpad spare part kit does not include the touchpad cable. The touchpad cable is included in the Cable Kit, spare part number N09288-001.	
	In natural silver finish	N08577-001
	In slate blue finish	N08578-001
(7b)	Touchpad cable: The touchpad cable is included in the Cable Kit, spare part number N09288-001.	
(8a)	Fingerprint reader (includes fingerprint extension cable)	
	NOTE: The fingerprint reader spare part kit does not include the fingerprint reader cable. The fingerprint reader cable is included in the Cable Kit, spare part number tbd-001.	
	In natural silver finish	N53653-001
	In slate blue finish	N53652-001
(8b)	Fingerprint reader cable: The fingerprint reader cable is included in the Cable Kit, spare part number tbd-001.	
(9)	Fan/heat sink assembly (includes replacement thermal material):	
	Standard fan/heat sink assembly	N11560-001
	Lightweight fan/heat sink assembly	N11561-001
	Thermal Material Kit (not illustrated)	N19698-001

Table 3-1 Computer major component descriptions and part numbers (continued)

Item	Component	Spare part number
(10)	System board (includes integrated processor, UMA graphics subsystem, and replacement thermal material):	
	Equipped with an Intel Core i7-1365U processor, 32 GB of system memory, and the Windows 11 operating system	N46513-601
	Equipped with an Intel Core i7-1365U processor, 32 GB of system memory, and a non-Windows operating system	N46513-001
	Equipped with an Intel Core i7-1365U processor, 16 GB of system memory, the Windows 11 operating system, for use on computer models equipped with an OLED display assembly	N46511-601
	Equipped with an Intel Core i7-1365U processor, 16 GB of system memory, a non- Windows operating system, for use on computer models equipped with an OLED display assembly	N46511-001
	Equipped with an Intel Core i7-1365U processor, 16 GB of system memory, OSR, and the Windows 11 operating system	N46512-601
	Equipped with an Intel Core i7-1365U processor, 16 GB of system memory, and OSR	N46512-001
	Equipped with an Intel Core i7-1365U processor, 16 GB of system memory, and the Windows 11 operating system	N46510-601
	Equipped with an Intel Core i7-1365U processor, 16 GB of system memory, and a non-Windows operating system	N46510-001
	Equipped with an Intel Core i7-1355U processor, 32 GB of system memory, and the Windows 11 operating system	N46509-601
	Equipped with an Intel Core i7-1355U processor, 32 GB of system memory, and a non-Windows operating system	N46509-001
	Equipped with an Intel Core i7-1355U processor, 16 GB of system memory, the Windows 11 operating system, for use on computer models equipped with an OLED display assembly	N46508-601
	Equipped with an Intel Core i7-1355U processor, 16 GB of system memory, a non- Windows operating system, for use on computer models equipped with an OLED display assembly	N46508-001
	Equipped with an Intel Core i7-1355U processor, 16 GB of system memory, and the Windows 11 operating system	N46507-601
	Equipped with an Intel Core i7-1355U processor, 16 GB of system memory, and a non-Windows operating system	N46507-001
	Equipped with an Intel Core i5-1345U processor, 32 GB of system memory, and the Windows 11 operating system	N46506-601
	Equipped with an Intel Core i5-1345U processor, 32 GB of system memory, and a non-Windows operating system	N46506-001
	Equipped with an Intel Core i5-1345U processor, 16 GB of system memory, OSR, and the Windows 11 operating system	N46505-601
	Equipped with an Intel Core i5-1345U processor, 16 GB of system memory, and OSR	N46505-001
	Equipped with an Intel Core i5-1345U processor, 16 GB of system memory, and the Windows 11 operating system	N46504-601
	Equipped with an Intel Core i5-1345U processor, 16 GB of system memory, and a non-Windows operating system	N46504-001
	Equipped with an Intel Core i5-1335U processor, 32 GB of system memory, and the Windows 11 operating system	N46503-601
	Equipped with an Intel Core i5-1335U processor, 32 GB of system memory, and a non-Windows operating system	N46503-001

Table 3-1 Computer major component descriptions and part numbers (continued)

Item	Component	Spare part number
	Equipped with an Intel Core i5-1335U processor, 16 GB of system memory, the Windows 11 operating system, for use on computer models equipped with an OLED display assembly	N46502-601
	Equipped with an Intel Core i5-1335U processor, 16 GB of system memory, a non- Windows operating system, for use on computer models equipped with an OLED display assembly	N46502-001
	Equipped with an Intel Core i5-1335U processor, 16 GB of system memory, and the Windows 11 operating system	N46501-601
	Equipped with an Intel Core i5-1335U processor, 16 GB of system memory, and a non-Windows operating system	N46501-001
	System Board Repair Support Kit (not illustrated)	N19699-888
(11)	Front speakers (included in the Speaker Kit; includes left and right front speakers, cables, and six rubber isolators)	N08563-001
(12)	WWAN module:	
	Intel 5000 5G Solution WWAN	N00181-005
	Intel XMM 7560 R+ LTE-Advanced Pro (Cat 16) WWAN	N00182-005
(13)	WWAN Cable Kit (includes WWAN cables and transceivers)	N11558-001
(14)	Interposer board	N11562-001
(15a)	Solid-state drive:	
	2 TB, M.2 2280, PCIe-4×4, ZTurbo solid-state drive with TLC	M52027-002
	1 TB, 2280, PCIe-4×4, NVMe solid-state drive with TLC	M16560-002
	1 TB, M.2 2280, PCIe-4×4, SED solid-state drive with TLC	N23415-002
	512 GB, M.2 2280, PCIe-4×4, NVMe, solid-state drive	N45476-002
	512 GB, 2280, PCIe-4×4, NVMe solid-state drive with TLC	M17436-002
	512 GB, M.2 2280, PCIe-4×4, SED solid-state drive with TLC	M52031-002
	256 GB, M.2 2280, PCIe, NVMe, value solid-state drive	M11042-002
	256 GB, M.2 2280, PCIe-4×4, NVMe, SED solid-state drive	M35225-002
(15b)	Solid-state drive shield: The solid-state drive shield is included in the Bracket Kit, spare part number N08562-001.	
(16)	Battery (includes cable):	
	6 cell, 68 Whr, 3.11 Ahr, LI	M73476-006
	4 cell, 45 Whr, 3.11 Ahr, LI	M73478-006
(17)	Bottom cover:	
	In natural silver finish for use on computer models equipped with WWAN capability	N18248-001
	In natural silver finish for use on computer models not equipped with WWAN capability	N08561-001
	In slate blue finish for use on computer models equipped with WWAN capability	N18247-001
	In slate blue finish for use on computer models not equipped with WWAN capability	N08560-001

Mass storage devices

To identify the mass storage devices, use this illustration and table.

Table 3-2 Mass storage device descriptions and part numbers

Component	Spare part number
2 TB, M.2 2280, PCIe-4×4, ZTurbo solid-state drive with TLC	M52027-001
1 TB, 2280, PCIe-4×4, NVMe solid-state drive with TLC	M16560-001
1 TB, M.2 2280, PCIe-4×4, SED solid-state drive with TLC	N23415-001
512 GB, M.2 2280, PCIe-4×4, NVMe, value solid-state drive	N04490-001
512 GB, 2280, PCIe-4×4, NVMe solid-state drive with TLC	M17436-001
512 GB, M.2 2280, PCIe-4×4, SED solid-state drive with TLC	M52031-001
256 GB, M.2 2280, PCIe-4×4, NVMe solid-state drive	M45477-001
256 GB, M.2 2280, PCIe-4×4, NVMe, SED solid-state drive	M35225-001

Cables

To identify the cables, use this illustration and table.

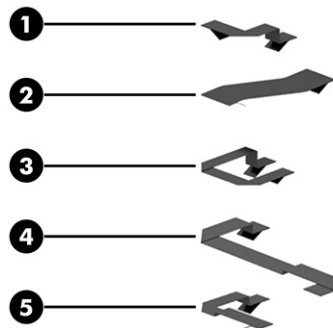

Table 3-3 Cable descriptions and part numbers

Item	Component
The cables listed below are included in the Cable Kit, spare part number N09288-001.	
(1)	Card reader cable
(2)	Connector board cable
(3)	Fingerprint reader cable
(4)	NFC module cable
(5)	Touchpad cable

Miscellaneous parts

To identify the miscellaneous parts, use this table.

Table 3-4 Miscellaneous part descriptions and part numbers

Component	Spare part number
AC adapter:	
280 W AC adapter (PFC, slim, 3P 7.4 mm)	M52952-001
120 W HP Smart Adapter (PFC, slim, 7.4 mm)	L89695-001
120 W HP Smart Adapter (PFC, RC, 4.5 mm)	M95377-001
65 W AC adapter (nPFC, USB Type-C, 1.8 m [6.0 ft])	L67440-001
65 W AC adapter (nPFC, USB Type-C, slim, 3 prong)	M54350-001
65 W AC adapter (USB Type-C)	N05175-001
AC adapter + power cord (C5, 1.0 m [3.3 ft], conventional with sticker) bundle for use in Thailand	M85418-001
AC adapter + power cord (C5, 1.0 m [3.3 ft], premium with sticker) bundle for use in Thailand	M85421-001
Adapter:	
HP HDMI-to-VGA adapter	701943-001
HP USB Type-C-to-DisplayPort adapter	831753-001
HP USB 3.0-to-Gigabit RJ-45 adapter	M95984-001
HP USB Type-C-to-HDMI 2.0 adapter	935325-001
HP USB Type-C-to-RJ-45 adapter	M95985-001
HP USB Type-C-to-USB 3.0 adapter	814618-001
HP USB Type-C-to-VGA adapter	831751-001
USB Type-C-to-USB Type-A adapter connector	L65254-001
Bag:	
HP business 14.1 inch laptop bag	M55007-001
HP business 14.1 inch slim top load bag	L05333-001
HP Prelude Pro 15.6 inch backpack	M03617-001
HP Prelude Pro 15.6 inch top load case	M03618-001
Bracket Kit (includes connector board I/O bracket, fingerprint reader bracket, memory module shield, SIM bracket, and solid-state drive shield)	N49522-001
Cable:	
USB Type-C male-to-USB Type-C male cable (1.0 m [3.0 ft])	L65253-001
HP Thunderbolt 4 120 W cable (0.8m [2.7 ft])	M88058-001
HP Thunderbolt 4 280 W cable (0.8m [2.7 ft])	M88059-001
Dock:	
HP 280 W G4 Thunderbolt dock with combination cable	M97106-001
HP 120 W G4 Thunderbolt dock with cable	M97105-001

Table 3-4 Miscellaneous part descriptions and part numbers (continued)

Component	Spare part number
HP 120 W Thunderbolt dock with cable	L15809-001
HP USB Type-A/C universal dock with cable	L64087-001
HP USB Type-C dock with cable	L64086-001
HP USB Type-C G5 dock	N31329-001
HP USB External DV D+-RW Drive	747080-001
Duck head adapter for use in Japan	L33157-001
Hub	
HP Universal USB Type-C MultiPort hub	M96882-001
HP USB Type-C-to-USB Type-A hub	916838-001
HP USB Type-C travel hub	L72056-001
HP USB keyboard for use in the United States	L95712-001
Lock:	
HP essential nano combination cable lock	N10501-001
HP nano combination cable lock	N10500-001
HP nano lock	918431-001
HP sure-key cable lock	L65088-001
Mouse:	
HP 435 wireless mouse	M62277-001
HP 128 laser wired mouse	M27885-001
HP Bluetooth travel mouse	L62043-001
HP USB mouse	L95713-001
Plastics Kit (includes card reader space holder, fingerprint reader space holder, left and right I/O space holders, and SIM space holder)	N48860-001
Power cord (C13, premium with tag):	
For use in Argentina	L32029-001
For use in Brazil	L32030-001
For use in Italy	L32031-001
Power cord (C13, 1.0 m [3.3 ft], LW, premium with tag):	
For use in Australia	L24670-001
For use in Denmark	L24672-001
For use in Europe	L24669-001
For use in India	L24679-001
For use in Israel	L24678-001
For use in Japan	L24680-001
For use in North America	L24671-001

Table 3-4 Miscellaneous part descriptions and part numbers (continued)

Component	Spare part number
For use in the People's Republic of China	L24676-001
For use in South Africa	L24674-001
For use in South Korea	L24675-001
For use in Switzerland	L24673-001
For use in Taiwan	L24677-001
For use in the United Kingdom	L24668-001
Power cord (C5, 1.0 m [3.3 ft], conventional with sticker):	
For use in Argentina	L19357-001
For use in Australia	L19358-001
For use in Brazil	L19359-001
For use in Denmark	L19360-001
For use in Europe	L19361-001
For use in India	L19363-001
For use in Israel	L19362-001
For use in Italy	L19364-001
For use in Japan	L19365-001
For use in North America	L19367-001
For use in the People's Republic of China	L19368-001
For use in South Africa	L19369-001
For use in South Korea	L19366-001
For use in Switzerland	L19370-001
For use in Taiwan	L19372-001
For use in Thailand	L19371-001
For use in the United Kingdom	L19373-001
Power cord (C5, 1.0 m [3.3 ft], conventional with sticker) and AC adapter bundle for use in Europe	N16170-001
Power cord (C5, 1.0 m [3.3 ft], conventional with sticker, HF):	
For use in Denmark	M79264-001
For use in Europe	M79266-001
For use in Switzerland	M79265-001
For use in the United Kingdom	M82711-001
Power cord (C5, 1.8 m [6.0 ft], conventional with sticker):	
For use in Argentina	L19357-002
For use in Australia	L19358-002
For use in Brazil	L19359-002

Table 3-4 Miscellaneous part descriptions and part numbers (continued)

Component	Spare part number
For use in Denmark	L19360-002
For use in Europe	L19361-002
For use in India	L19363-002
For use in Israel	L19362-002
For use in Italy	L19364-002
For use in Japan	L19365-002
For use in North America	L19367-002
For use in the People's Republic of China	L19368-002
For use in South Africa	L19369-002
For use in South Korea	L19366-002
For use in Switzerland	L19370-002
For use in Taiwan	L19372-002
For use in Thailand	L19371-002
For use in the United Kingdom	L19373-002
Power cord (C5, 1.0 m [3.3 ft], premium with tag):	
For use in Argentina	L30811-001
For use in Australia	L22327-001
For use in Brazil	L30812-001
For use in Denmark	L22322-001
For use in Europe	L22321-001
For use in India	L22624-001
For use in Israel	L22323-001
For use in Italy	L30813-001
For use in Japan	L22330-001
For use in North America	L22319-001
For use in the People's Republic of China	L21930-001
For use in South Africa	L22325-001
For use in South Korea	L22328-001
For use in Switzerland	L22324-001
For use in Taiwan	L22329-001
For use in Thailand	L22326-001
For use in the United Kingdom	L22320-001
Power cord (C5, 1.8 m [6.0 ft], FX, DH, premium with sticker) for use in Brazil	N19341-002
Screw Kit	N02339-001

4 Removal and replacement procedures preliminary requirements

Use this information to properly prepare to disassemble and reassemble the computer.

Tools required

You need the following tools to complete the removal and replacement procedures:

- Tweezers
- Nonconductive, nonmarking pry tool
- Magnetic Phillips P1 screwdriver

Service considerations

The following sections include some of the considerations that you must keep in mind during disassembly and assembly procedures.

 **NOTE:** As you remove each subassembly from the computer, place the subassembly (and all accompanying screws) away from the work area to prevent damage.

Plastic parts

Using excessive force during disassembly and reassembly can damage plastic parts.

Cables and connectors

Handle cables with extreme care to avoid damage.

 **IMPORTANT:** When servicing the computer, be sure that cables are placed in their proper locations during the reassembly process. Improper cable placement can damage the computer.

Apply only the tension required to unseat or seat the cables during removal and insertion. Handle cables by the connector whenever possible. In all cases, avoid bending, twisting, or tearing cables. Be sure that cables are routed so that they cannot be caught or snagged as you remove or replace parts. Handle flex cables with extreme care; these cables tear easily.

Drive handling

Note the following guidelines when handling drives.

 **IMPORTANT:** Drives are fragile components. Handle them with care. To prevent damage to the computer, damage to a drive, or loss of information, observe these precautions:

- Before removing or inserting a hard drive, shut down the computer. If you are unsure whether the computer is off or in Hibernation, turn the computer on, and then shut it down through the operating system.
 - Before handling a drive, be sure that you are discharged of static electricity. While handling a drive, avoid touching the connector.
 - Before removing an optical drive, be sure that a disc is not in the drive, and be sure that the optical drive tray is closed.
 - Handle drives on surfaces covered with at least 2.54 cm (1 inch) of shock-proof foam.
 - Avoid dropping drives from any height onto any surface.
 - After removing a hard drive or an optical drive, place it in a static-proof bag.
 - Avoid exposing an internal hard drive to products that have magnetic fields, such as monitors or speakers.
 - Avoid exposing a drive to temperature extremes or liquids.
 - If a drive must be mailed, place the drive in a bubble pack mailer or other suitable form of protective packaging, and label the package “FRAGILE.”
-

Electrostatic discharge information

A sudden discharge of static electricity from your finger or other conductor can destroy static-sensitive devices or microcircuitry. Often the spark is neither felt nor heard, but damage occurs. An electronic device exposed to electrostatic discharge (ESD) might not appear to be affected at all and can work perfectly throughout a normal cycle. The device might function normally for a while, but it has been degraded in the internal layers, reducing its life expectancy.

Networks built into many integrated circuits provide some protection, but in many cases, the discharge contains enough power to alter device parameters or melt silicon junctions.

 **IMPORTANT:** To prevent damage to the device when you remove or install internal components, observe these precautions:

- Keep components in their electrostatic-safe containers until you are ready to install them.
 - Before touching an electronic component, discharge static electricity by using the guidelines described in [Personal grounding methods and equipment on page 41](#).
 - Avoid touching pins, leads, and circuitry. Handle electronic components as little as possible.
 - If you remove a component, place it in an electrostatic-safe container.
-

Generating static electricity

Follow these static electricity guidelines:

- Different activities generate different amounts of static electricity.
- Static electricity increases as humidity decreases.

Table 4-1 Static electricity occurrence based on activity and humidity

Event	Relative humidity		
	55%	40%	10%
Walking across carpet	7,500 V	15,000 V	35,000 V
Walking across vinyl floor	3,000 V	5,000 V	12,000 V
Motions of bench worker	400 V	800 V	6,000 V
Removing dual in-line packages (DIPs) from plastic tube	400 V	700 V	2,000 V
Removing DIPs from vinyl tray	2,000 V	4,000 V	11,500 V
Removing DIPs from polystyrene foam	3,500 V	5,000 V	14,500 V
Removing bubble pack from PCB (printed circuit board)	7,000 V	20,000 V	26,500 V
Packing PCBs in foam-lined box	5,000 V	11,000 V	21,000 V

Multiple electric components can be packaged together in plastic tubes, trays, or polystyrene foam.

 **NOTE:** As little as 700 V of static electricity can degrade a product.

Preventing electrostatic damage to equipment

Many electronic components are sensitive to ESD. Circuitry design and structure determine the degree of sensitivity.

The following packaging and grounding precautions are necessary to prevent static electricity damage to electronic components:

- To avoid hand contact, transport products in static-safe containers such as tubes, bags, or boxes.
- Protect all electrostatic parts and assemblies with conductive or approved containers or packaging.
- Keep electrostatic-sensitive parts in their containers until they arrive at static-free stations.
- Place items on a grounded surface before removing them from their container.
- Always be properly grounded when touching a sensitive component or assembly.
- Avoid contact with pins, leads, or circuitry.
- Place reusable electrostatic-sensitive parts from assemblies in protective packaging or conductive foam.

Personal grounding methods and equipment

Using certain equipment can prevent static electricity damage to electronic components.

- **Wrist straps** are flexible straps with a maximum of $1\text{ M}\Omega \pm 10\%$ resistance in the ground cords. To provide proper ground, a strap must be worn snug against bare skin. The ground cord must be connected and fit snugly into the banana plug connector on the grounding mat or workstation.
- You can use **heel straps, toe straps, and boot straps** at standing workstations. These straps are compatible with most types of shoes or boots. On conductive floors or dissipative floor mats, use them on both feet with a maximum of $1\text{ M}\Omega \pm 10\%$ resistance between the operator and ground.

Table 4-2 Static shielding protection levels

Static shielding protection levels	
Method	Voltage
Antistatic plastic	1,500
Carbon-loaded plastic	7,500
Metallized laminate	15,000

Grounding the work area

To prevent static damage at the work area, follow these precautions:

- Cover the work surface with approved static-dissipative material.
- Use a wrist strap connected to a properly grounded work surface and use properly grounded tools and equipment.
- Use static-dissipative mats, foot straps, or air ionizers to give added protection.
- Handle electrostatic sensitive components, parts, and assemblies by the case or PCB laminate. Handle them only at static-free work areas.
- Turn off power and input signals before inserting and removing connectors or test equipment.
- Use fixtures made of static-safe materials when fixtures must directly contact dissipative surfaces.
- Keep the work area free of nonconductive materials, such as ordinary plastic assembly aids and polystyrene foam.
- Use conductive field service tools, such as cutters, screwdrivers, and vacuums.
- Avoid contact with pins, leads, or circuitry.

Recommended materials and equipment

HP recommends certain materials and equipment to prevent static electricity:

- Antistatic tape
- Antistatic smocks, aprons, or sleeve protectors
- Conductive bins and other assembly or soldering aids
- Conductive foam
- Conductive tabletop workstations with ground cord of $1\text{ M}\Omega \pm 10\%$ resistance
- Static-dissipative table or floor mats with hard tie to ground
- Field service kits
- Static awareness labels
- Wrist straps and footwear straps providing $1\text{ M}\Omega \pm 10\%$ resistance
- Material handling packages

- Conductive plastic bags
- Conductive plastic tubes
- Conductive tote boxes
- Opaque shielding bags
- Transparent metallized shielding bags
- Transparent shielding tubes

Cleaning your computer

Cleaning your computer regularly removes dirt and debris so that your device continues to operate at its best. Use the following information to safely clean the external surfaces of your computer.

Enabling HP Easy Clean (select products only)

HP Easy Clean helps you to avoid accidental input while you clean the computer surfaces. This software disables devices such as the keyboard, touch screen, and touchpad for a preset amount of time so that you can clean all computer surfaces.

1. Start HP Easy Clean in one of the following ways:
 - Select the **Start** menu, and then select **HP Easy Clean**.
- or -
 - Select the **HP Easy Clean** icon in the taskbar.
- or -
 - Select **Start**, and then select the **HP Easy Clean** tile.
2. Now that your device is disabled for a short period, see [Removing dirt and debris from your computer on page 43](#) for the recommended steps to clean the high-touch, external surfaces on your computer. After you remove the dirt and debris, you can also clean the surfaces with a disinfectant. See [Cleaning your computer with a disinfectant on page 44](#) for guidelines to help prevent the spread of harmful bacteria and viruses.

Removing dirt and debris from your computer

Here are the recommended steps to clean dirt and debris from your computer.

For computers with wood veneer, see [Caring for wood veneer \(select products only\) on page 45](#).

1. Wear disposable gloves made of latex (or nitrile gloves, if you are latex-sensitive) when cleaning the surfaces.
2. Turn off your device and unplug the power cord and other connected external devices. Remove any installed batteries from items such as wireless keyboards.

 **CAUTION:** To prevent electric shock or damage to components, never clean a product while it is turned on or plugged in.

3. Moisten a microfiber cloth with water. The cloth should be moist, but not dripping wet.

 **IMPORTANT:** To avoid damaging the surface, avoid abrasive cloths, towels, and paper towels.

4. Wipe the exterior of the product gently with the moistened cloth.

 **IMPORTANT:** Keep liquids away from the product. Avoid getting moisture in any openings. If liquid makes its way inside your HP product, it can cause damage to the product. Do not spray liquids directly on the product. Do not use aerosol sprays, solvents, abrasives, or cleaners containing hydrogen peroxide or bleach that might damage the finish.

5. Start with the display (if applicable). Wipe carefully in one direction, and move from the top of the display to the bottom. Finish with any flexible cables, like power cord, keyboard cable, and USB cables.
6. Be sure that surfaces have completely air-dried before turning the device on after cleaning.
7. Discard the gloves after each cleaning. Clean your hands immediately after you remove the gloves.

See [Cleaning your computer with a disinfectant on page 44](#) for recommended steps to clean the high-touch, external surfaces on your computer to help prevent the spread of harmful bacteria and viruses.

Cleaning your computer with a disinfectant

The World Health Organization (WHO) recommends cleaning surfaces, followed by disinfection, as a best practice for preventing the spread of viral respiratory illnesses and harmful bacteria.

After cleaning the external surfaces of your computer using the steps in [Removing dirt and debris from your computer on page 43](#), [Caring for wood veneer \(select products only\) on page 45](#), or both, you might also choose to clean the surfaces with a disinfectant. A disinfectant that is within HP's cleaning guidelines is an alcohol solution consisting of 70% isopropyl alcohol and 30% water. This solution is also known as rubbing alcohol and is sold in most stores.

Follow these steps when disinfecting high-touch, external surfaces on your computer:

1. Wear disposable gloves made of latex (or nitrile gloves, if you are latex-sensitive) when cleaning the surfaces.
2. Turn off your device and unplug the power cord and other connected external devices. Remove any installed batteries from items such as wireless keyboards.

 **CAUTION:** To prevent electric shock or damage to components, never clean a product while it is turned on or plugged in.

3. Moisten a microfiber cloth with a mixture of 70% isopropyl alcohol and 30% water. The cloth should be moist, but not dripping wet.

 **CAUTION:** Do not use any of the following chemicals or any solutions that contain them, including spray-based surface cleaners: bleach, peroxides (including hydrogen peroxide), acetone, ammonia, ethyl alcohol, methylene chloride, or any petroleum-based materials, such as gasoline, paint thinner, benzene, or toluene.

 **IMPORTANT:** To avoid damaging the surface, avoid abrasive cloths, towels, and paper towels.

4. Wipe the exterior of the product gently with the moistened cloth.

 **IMPORTANT:** Keep liquids away from the product. Avoid getting moisture in any openings. If liquid makes its way inside your HP product, it can cause damage to the product. Do not spray liquids directly on the product. Do not use aerosol sprays, solvents, abrasives, or cleaners containing hydrogen peroxide or bleach that might damage the finish.

5. Start with the display (if applicable). Wipe carefully in one direction, and move from the top of the display to the bottom. Finish with any flexible cables, like power cord, keyboard cable, and USB cables.
6. Be sure that surfaces have completely air-dried before turning the device on after cleaning.
7. Discard the gloves after each cleaning. Clean your hands immediately after you remove the gloves.

Caring for wood veneer (select products only)

Your product might feature high-quality wood veneer. As with all natural wood products, proper care is important for best results over the life of the product. Because of the nature of natural wood, you might see unique variations in the grain pattern or subtle variations in color, which are normal.

- Clean the wood with a dry, static-free microfiber cloth or chamois.
- Avoid cleaning products containing substances such as ammonia, methylene chloride, acetone, turpentine, or other petroleum-based solvents.
- Do not expose the wood to sun or moisture for long periods of time.
- If the wood becomes wet, dry it by dabbing with an absorbent, lint-free cloth.
- Avoid contact with any substance that might dye or discolor the wood.
- Avoid contact with sharp objects or rough surfaces that might scratch the wood.

See [Removing dirt and debris from your computer on page 43](#) for the recommended steps to clean the high-touch, external surfaces on your computer. After you remove the dirt and debris, you can also clean the surfaces with a disinfectant. See [Cleaning your computer with a disinfectant on page 44](#) for sanitizing guidelines to help prevent the spread of harmful bacteria and viruses.

Packaging and transporting guidelines

Follow these grounding guidelines when packaging and transporting equipment:

- To avoid hand contact, transport products in static-safe tubes, bags, or boxes.
- Protect ESD-sensitive parts and assemblies with conductive or approved containers or packaging.
- Keep ESD-sensitive parts in their containers until the parts arrive at static-free workstations.
- Place items on a grounded surface before removing items from their containers.
- Always be properly grounded when touching a component or assembly.
- Store reusable ESD-sensitive parts from assemblies in protective packaging or nonconductive foam.

- Use transporters and conveyors made of antistatic belts and roller bushings. Be sure that mechanized equipment used for moving materials is wired to ground and that proper materials are selected to avoid static charging. When grounding is not possible, use an ionizer to dissipate electric charges.

Accessing support information

To find the HP support that you need, use this information.

Table 4-3 Support information locations



Service consideration	Path to access information
Records of reported failure incidents stored on the computer	<p>Windows®:</p> <p>Preoperating system failures are logged in the BIOS Event Log. To view the BIOS Event Log:</p> <ol style="list-style-type: none"> 1. Press the power button. 2. Immediately and repeatedly press esc when the power button light turns white. <p>NOTE: If you do not press esc at the appropriate time, you must restart the computer and again repeatedly press esc when the power button light turns white to access the utility.</p> <ol style="list-style-type: none"> 3. Press f10 to enter the BIOS setup. 4. (On commercial products) Under the Main tab, select BIOS event log, and then select View BIOS Event Log. <p>- or -</p> <p>(On consumer products) Under the Main tab, select System Log.</p> <p>Post-operating system failures are logged in the Event Viewer.</p> <ol style="list-style-type: none"> 1. Turn on the computer and allow the operating system to open. 2. Select the search icon  in the taskbar. 3. Type <code>Event Viewer</code>, and then press enter. 4. Select the log from the left panel. Details display in the right panel. <p>Chrome™:</p> <ol style="list-style-type: none"> 1. Go to support.google.com/chrome. 2. Search <code>collect Chrome device logs</code>.
Technical bulletins	<p>To locate technical bulletins:</p> <ol style="list-style-type: none"> 1. Go to www.hp.com. 2. Place the cursor over Problem solving to display more options. 3. Select Support & Troubleshooting. 4. Type the serial number, product number, or product name to go to the product support page. 5. Select Advisories to view technical bulletins.

Table 4-3 Support information locations (continued)

Service consideration	Path to access information
Repair professionals	To locate repair professionals: <ol style="list-style-type: none"><li data-bbox="703 310 932 331">1. Go to www.hp.com.<li data-bbox="703 359 1362 380">2. Place the cursor over Support resources to display more options.<li data-bbox="703 407 1091 428">3. Select Authorized service providers.
Component and diagnosis information, failure detection, and required action	To locate diagnosis information and actions: <ol style="list-style-type: none"><li data-bbox="703 506 1203 527">1. Go to http://www.hp.com/go/techcenter/pcdiags.<li data-bbox="703 554 932 575">2. Select Get Support.<li data-bbox="703 602 1445 648">3. Near the bottom of the window, select Notebook PCs, and then select your location.

5 Removal and replacement procedures for authorized service provider parts

This chapter provides removal and replacement procedures for authorized service provider parts.

 **IMPORTANT:** Only an authorized service provider should access the components described in this chapter.

 **NOTE:** Details about your computer, including model, serial number, product key, and length of warranty, are on the service tag at the bottom of your computer.

Component replacement procedures

To remove and replace computer components, use the procedures described in this section.

 **NOTE:** HP continually improves and changes product parts. For complete and current information about supported parts for your computer, go to <http://partsurfer.hp.com>, select your country or region, and then follow the on-screen instructions.

You must remove, replace, or loosen as many as 46 screws when you service the parts described in this chapter. Make special note of each screw size and location during removal and replacement.

Preparation for disassembly

To remove and replace computer components, use these procedures.

For initial safety procedures, see [Removal and replacement procedures preliminary requirements on page 39](#).

1. Turn off the computer. If you are unsure whether the computer is off or in Hibernation, turn the computer on, and then shut it down through the operating system.
2. Disconnect the power from the computer by unplugging the power cord from the computer.
3. Disconnect all external devices from the computer.

Bottom cover

To remove the bottom cover, use this procedure and illustration.

Table 5-1 Bottom cover descriptions and part numbers

Description	Spare part number
In natural silver finish for use on computer models equipped with WWAN capability	N18248-001
In natural silver finish for use on computer models not equipped with WWAN capability	N08561-001
In slate blue finish for use on computer models equipped with WWAN capability	N18247-001
In slate blue finish for use on computer models not equipped with WWAN capability	N08560-001

Before removing the bottom cover, prepare the computer for disassembly (see [Preparation for disassembly on page 48](#)).

Remove the bottom cover:

1. Loosen the four Phillips captive screws that secure the bottom cover to the computer.

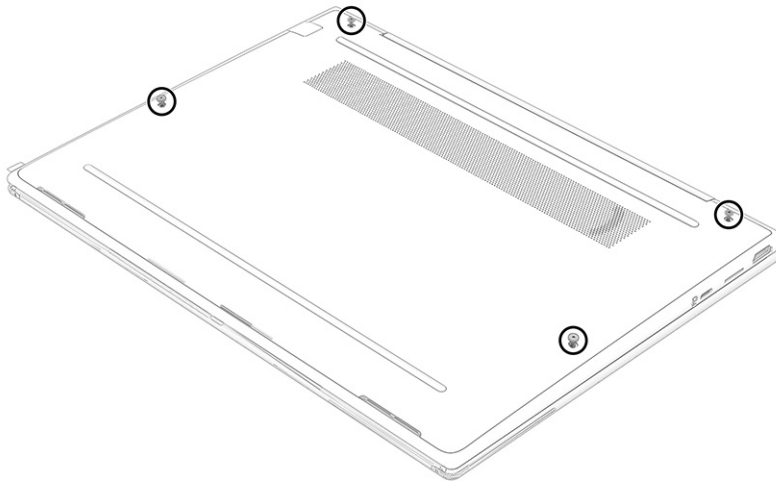

2. Use a nonmarking, nonconductive tool **(1)** to separate the rear edge of the bottom cover **(2)** from the computer.

3. Remove the bottom cover (3) from the computer.

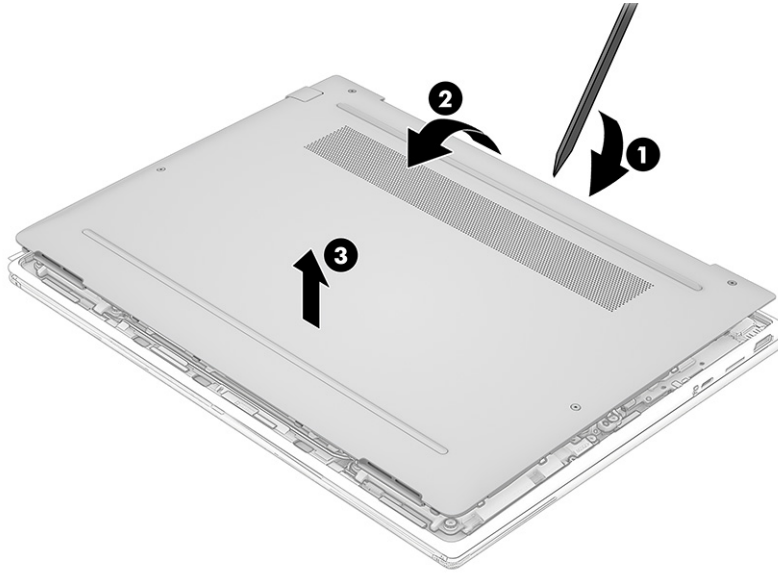

To replace the bottom cover, reverse the removal procedures.

Battery

To remove the battery, use this procedure and illustration.

Table 5-2 Battery descriptions and part numbers

Description	Spare part number
Battery (includes cable):	
6 cell, 68 Whr, 3.11 Ahr, LI	M73476-006
4 cell, 45 Whr, 3.11 Ahr, LI	M73478-006

⚠ WARNING! To avoid personal injury and damage to the product:

- Do *not* puncture, twist, or crack the battery.
- Do *not* cause an external puncture or rupture to the battery. They can cause a short inside the battery, which can result in battery thermal runaway.
- Do *not* handle or touch the battery enclosure with sharp objects such as tweezers or pliers, which might puncture the battery.
- Do *not* compress or squeeze the battery case with tools or heavy objects stacked on top of the case. These actions can apply undue force on the battery.
- Do *not* touch the connectors with any metallic surface or object, such as metal tools, screws, or coins, which can cause shorting across the connectors.

Before removing the battery, follow these steps:

1. Prepare the computer for disassembly (see [Preparation for disassembly on page 48](#)).

2. Remove the bottom cover (see [Bottom cover on page 48](#)).

⚠ WARNING! To reduce potential safety issues, use only the user-replaceable battery provided with the computer, a replacement battery provided by HP, or a compatible battery purchased from HP.

📌 IMPORTANT: Removing a battery that is the sole power source for the computer can cause loss of information. To prevent loss of information, save your work or shut down the computer through Windows before you remove the battery.

Remove the battery:

1. Disconnect the battery cable (1) from the system board.
2. Remove the five Phillips M2.0 × 3.9 screws (2) that secure the battery to the computer.
3. Remove the battery (3) from the computer.

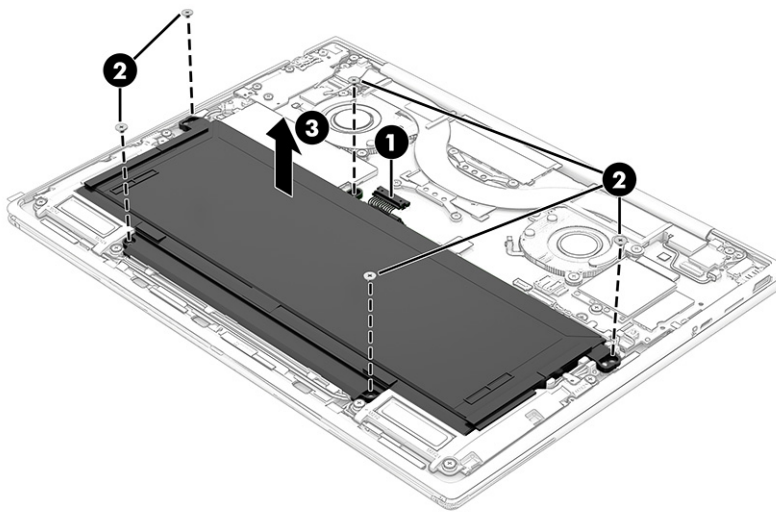

To install the battery, reverse the removal procedures.

Solid-state drive

To remove the solid-state drive, use this procedure and illustration.

Table 5-3 Solid-state drive descriptions and part numbers

Description	Spare part number
2 TB, M.2 2280, PCIe-4×4, ZTurbo solid-state drive with TLC	M52027-001
1 TB, 2280, PCIe-4×4, NVMe solid-state drive with TLC	M16560-001
1 TB, M.2 2280, PCIe-4×4, SED solid-state drive with TLC	N23415-001
512 GB, M.2 2280, PCIe-4×4, NVMe, solid-state drive	N45476-001
512 GB, 2280, PCIe-4×4, NVMe solid-state drive with TLC	M17436-001
512 GB, M.2 2280, PCIe-4×4, SED solid-state drive with TLC	M52031-001
256 GB, M.2 2280, PCIe, NVMe, value solid-state drive	M11042-001
256 GB, M.2 2280, PCIe-4×4, NVMe, SED solid-state drive	M35225-001

Before removing the solid-state drive, follow these steps:

1. Prepare the computer for disassembly (see [Preparation for disassembly on page 48](#)).
2. Remove the bottom cover (see [Bottom cover on page 48](#)).
3. Disconnect the battery cable from the system board (see [Battery on page 50](#)).

Remove the solid-state drive:

1. Remove the solid-state drive shield (1).

The solid-state drive shield is included in the Bracket Kit, spare part number N08562-001.

2. Remove the Phillips M2.0 × 3.9 screw (2) that secures the solid-state drive to the computer.
3. Remove the solid-state drive (3) by sliding it out of the socket at an upward angle.

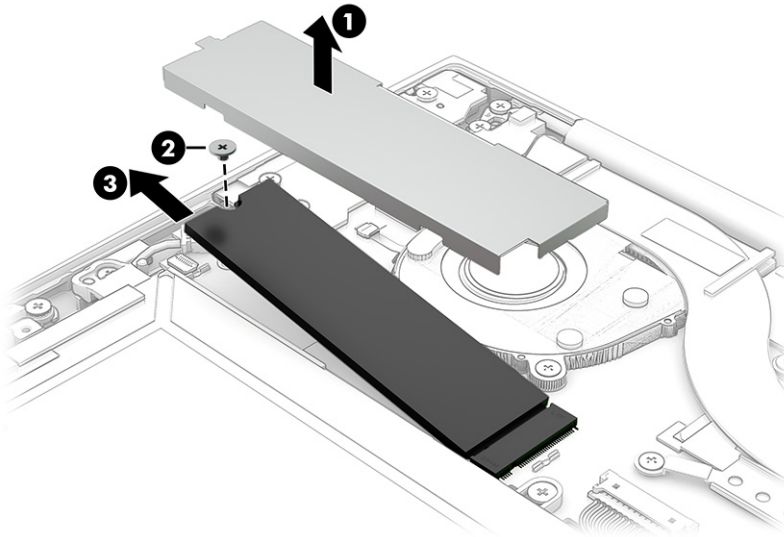

4. Thoroughly clean the thermal material from the surfaces of the solid-state drive and the solid-state drive shield each time the solid-state drive shield is removed. Replacement thermal material is included with the solid-state drive shield spare part kit. The following illustration shows the replacement thermal material locations.

A thermal pad is used on the solid-state drive (1) and on the solid-state drive shield area (2) that services it.

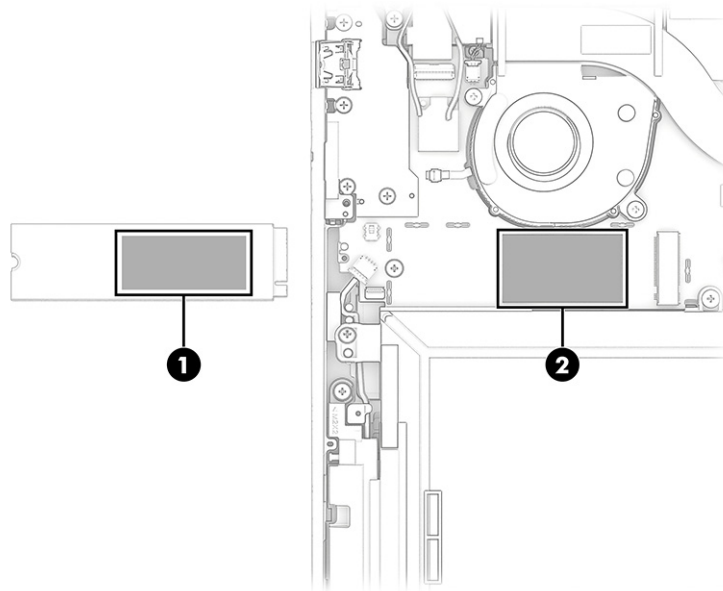

To install a solid-state drive, reverse the removal procedures.

 **NOTE:** Solid-state drives are designed with a notch to prevent incorrect insertion.

WWAN module

To remove the WWAN module, use this procedure and illustration.

Table 5-4 WWAN module descriptions and part numbers

Description	Spare part number
Intel 5000 5G WWAN module	N00181-005
Intel XMM 7560 R+ LTE-Advanced Pro (Cat 16) WWAN module	N00182-005

 **IMPORTANT:** To prevent an unresponsive system, replace the wireless module only with a wireless module authorized for use in the computer by the governmental agency that regulates wireless devices in your country or region. If you replace the module and then receive a warning message, remove the module to restore device functionality, and then contact technical support.

Before removing the WWAN module, follow these steps:

1. Prepare the computer for disassembly (see [Preparation for disassembly on page 48](#)).
2. Remove the bottom cover (see [Bottom cover on page 48](#)).
3. Disconnect the battery cable from the system board (see [Battery on page 50](#)).

Remove the WWAN module:

1. Carefully disconnect the WWAN module antenna cables **(1)** from the WWAN module.

 **NOTE:** Computer models have one to four WWAN module antenna cables. The antenna cables have tags that identify them with a number that corresponds to a terminal on the WWAN module. Connect the antenna cable to the corresponding WWAN module terminal.

- Remove the Phillips M2.0 × 3.9 screw (2), and then remove the WWAN module (3).

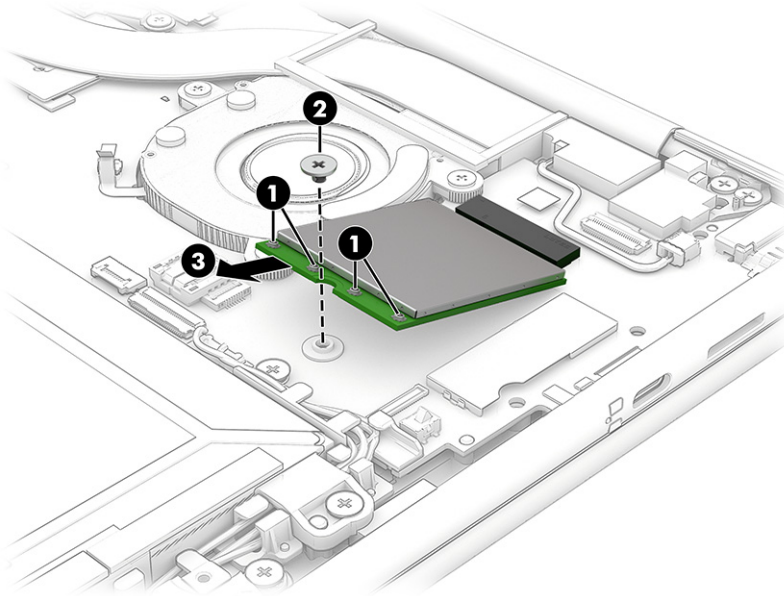

- If the WWAN module antenna is not connected to the terminal on the WWAN module, install a protective sleeve on the antenna connector, as shown in the following illustration.

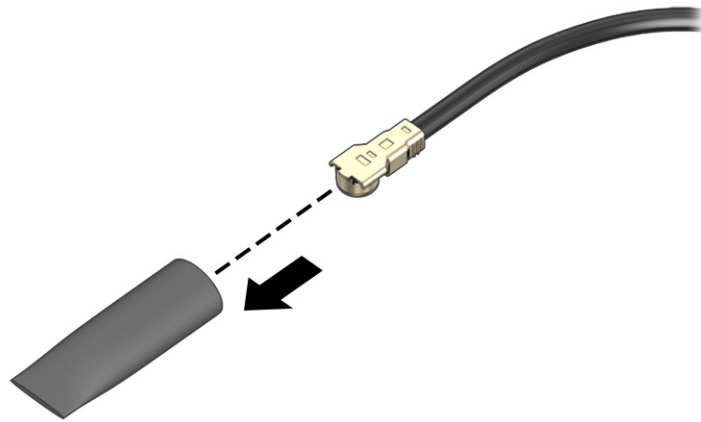

To install the WWAN module, reverse the removal procedures.

Connector board

To remove the connector board, use this procedure and illustration.

Table 5-5 Connector board descriptions and part numbers

Description	Spare part number
Connector board (includes USB port and microSD slot)	
In natural silver finish	N11564-001

Table 5-5 Connector board descriptions and part numbers (continued)

Description	Spare part number
In slate blue finish	N16841-001

Before removing the connector board, follow these steps:

1. Prepare the computer for disassembly (see [Preparation for disassembly on page 48](#)).
2. Remove the bottom cover (see [Bottom cover on page 48](#)).
3. Disconnect the battery cable from the system board (see [Battery on page 50](#)).

Remove the connector board:

1. Remove the four Phillips M2.0 × 3.9 screws (1) that secure the connector board to the computer.
2. Remove the connector board (2) and disconnect it from the interposer board.
3. If it is necessary to replace the interposer board (3), remove the interposer board by lifting it straight up.

The interposer board is available using spare part number N11562-001.

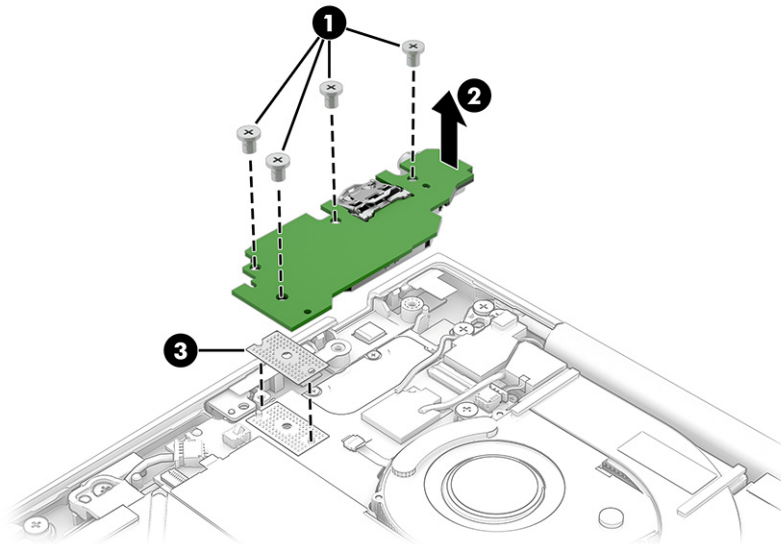

To install the connector board and interposer board, reverse this procedure.

Display assembly

To remove and disassemble the display assembly, use these procedures and illustrations.

Table 5-6 Display assembly descriptions and part numbers

Description	Spare part number
In natural silver finish:	
34.3 cm (13.5 in), LCD, WUXGA (1920 × 1200), nantiglare, UWVA, TOP display panel; typical brightness: 1000 nits	N51331-001

Table 5-6 Display assembly descriptions and part numbers (continued)

Description	Spare part number
34.3 cm (13.5 in), LCD, WUXGA (1920 × 1200), antiglare, UWVA, TOP display panel; typical brightness: 400 nits	N51330-001
34.3 cm (13.5 in), LCD, WUXGA (1920 × 1200), nantiglare, UWVA, TOP display panel; typical brightness: 400 nits	N51333-001
34.3 cm (13.5 in), LCD, UHD, WUXGA (3000 × 2000), brightview, OLED, UWVA, non-TOP display panel; typical brightness: 400 nits	N51334-001
34.3 cm (13.5 in), LCD, WUXGA (1920 × 1200), UWVA, non-TOP display panel with privacy filter; typical brightness: 1000 nits	N51329-001
34.3 cm (13.5 in), LCD, WUXGA (1920 × 1200), UWVA, non-TOP display panel; typical brightness: 400 nits	N51332-001
In slate blue finish:	
34.3 cm (13.5 in), LCD, WUXGA (1920 × 1200), nantiglare, UWVA, TOP display panel; typical brightness: 1000 nits	N51337-001
34.3 cm (13.5 in), LCD, WUXGA (1920 × 1200), antiglare, UWVA, TOP display panel; typical brightness: 400 nits	N51336-001
34.3 cm (13.5 in), LCD, WUXGA (1920 × 1200), nantiglare, UWVA, TOP display panel; typical brightness: 400 nits	N51339-001
34.3 cm (13.5 in), LCD, WUXGA (1920 × 1200), UWVA, non-TOP display panel with privacy filter; typical brightness: 1000 nits	N51335-001
34.3 cm (13.5 in), LCD, WUXGA (1920 × 1200), UWVA, non-TOP display panel; typical brightness: 400 nits	N51338-001

Before removing the display panel, follow these steps:

1. Prepare the computer for disassembly (see [Preparation for disassembly on page 48](#)).
2. Remove the bottom cover (see [Bottom cover on page 48](#)).
3. Disconnect the battery cable from the system board (see [Battery on page 50](#)).

Remove the display assembly:

1. Release the zero insertion force (ZIF) connector the webcam cable **(1)** is connected to, and then disconnect the webcam cable from the system board.
2. Carefully disconnect the WLAN module antenna cables **(2)** from the WLAN module.



NOTE: Computer models have one or two WLAN module antenna cables. The antenna cables have tags that identify them with a number that corresponds to a terminal on the WLAN module. Connect the antenna cable to the corresponding WLAN module terminal.

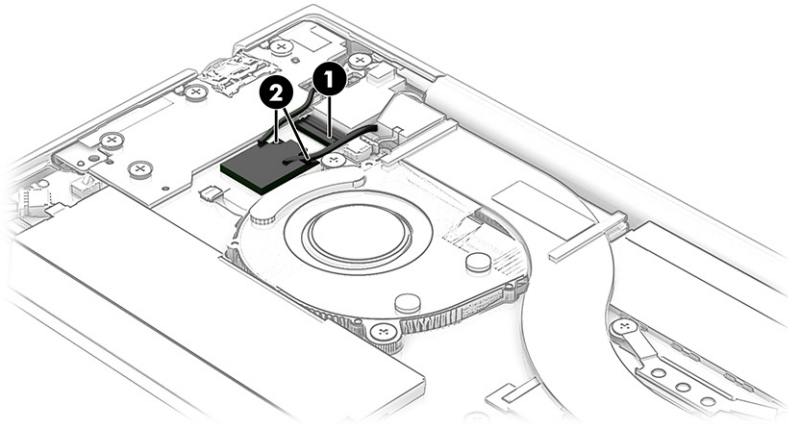

3. Release the ZIF connector the display panel cable (1) is connected to, and then disconnect the display panel cable from the system board.
4. Carefully disconnect the WWAN module antenna cables (2) from the WWAN module.

 **NOTE:** Computer models have one to four WWAN module antenna cables. The antenna cables have tags that identify them with a number that corresponds to a terminal on the WWAN module. Connect the antenna cable to the corresponding WWAN module terminal.

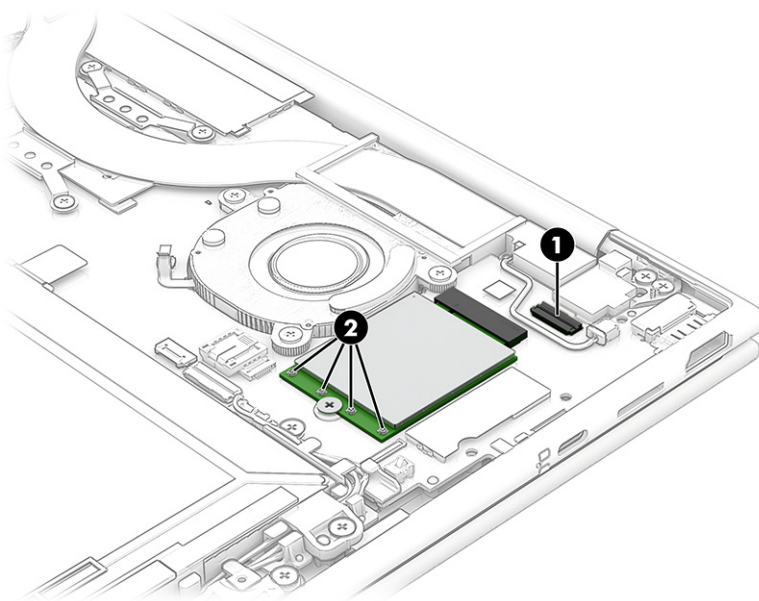

- Remove the six Phillips M2.5 × 4.3 screws that secure the display assembly to the computer.

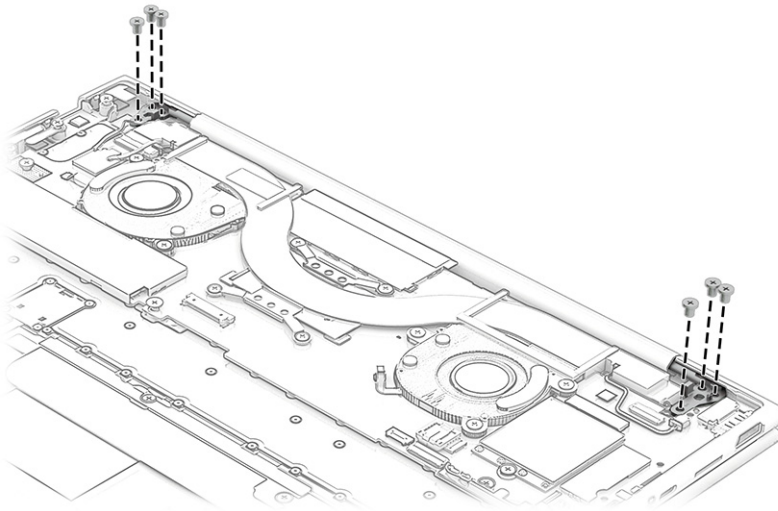

- Swing the top edge of the display assembly (1) away from the computer.
- Release the display hinges (2) from the computer.
- Remove the display assembly (3) from the computer.

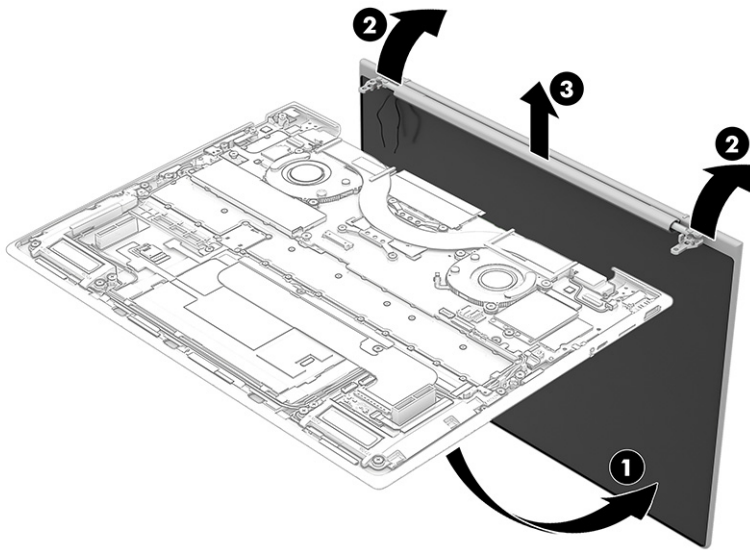

To install the display assembly, reverse this procedure.

Fan/heat sink assembly

To remove the fan/heat sink assembly, use these procedures and illustrations.

Table 5-7 Fan/heat sink assembly descriptions and part numbers

Description	Spare part number
Fan/heat sink assembly (includes captive screws and replacement thermal material):	

Table 5-7 Fan/heat sink assembly descriptions and part numbers (continued)

Description	Spare part number
Standard fan/heat sink assembly	N11560-001
Lightweight fan/heat sink assembly	N11561-001

Before removing the fan/heat sink assembly, follow these steps:

1. Prepare the computer for disassembly (see [Preparation for disassembly on page 48](#)).
2. Remove the bottom cover (see [Bottom cover on page 48](#)).
3. Disconnect the battery cable from the system board (see [Battery on page 50](#)).

Remove the fan/heat sink assembly:

1. Disconnect the two fan cables (1) from the system board.
2. Loosen the five captive screws (2) that secure the fans to the computer.
3. In the order indicated on the fan/heat sink assembly, loosen the four Phillips captive screws (3) that secure the fan/heat sink assembly to the computer.
4. Remove the fan/heat sink assembly (4) from the computer.

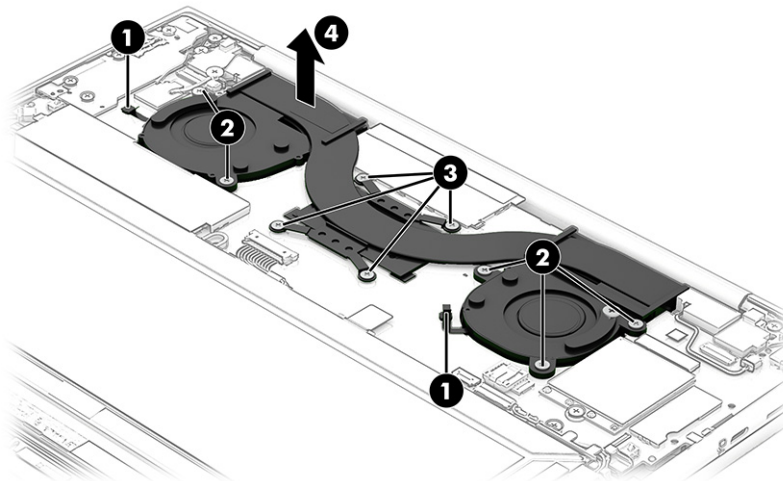

5. Thoroughly clean the thermal material from the surfaces of the fan/heat sink assembly and the system board components each time the fan/heat sink assembly is removed. Replacement thermal material is included with the fan/heat sink assembly and system board spare part kits. The following illustration shows the replacement thermal material locations.

Thermal paste is used on the system board processor (1) and on the fan/heat sink assembly area (2) that services it.

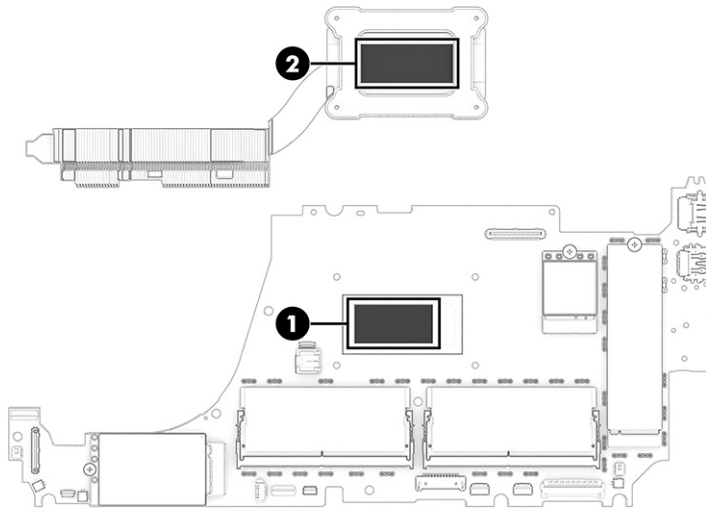

To install the fan/heat sink assembly, reverse this procedure.

Rear speakers

To remove the rear speakers, use this procedure and illustration.

Table 5-8 Rear speakers description and part number

Description	Spare part number
Speaker Kit (includes left and right rear speakers and cables)	N08563-001

Before removing the rear speakers, follow these steps:

1. Prepare the computer for disassembly (see [Preparation for disassembly on page 48](#)).
2. Remove the bottom cover (see [Bottom cover on page 48](#)).
3. Disconnect the battery cable from the system board (see [Battery on page 50](#)).

Remove the rear speakers:

1. Release the right rear speaker cable from the retention clip **(1)** that is built into the top cover with keyboard.
2. Disconnect the speaker cables **(2)** from the system board connectors.

- Remove the rear speakers (3) from the computer.

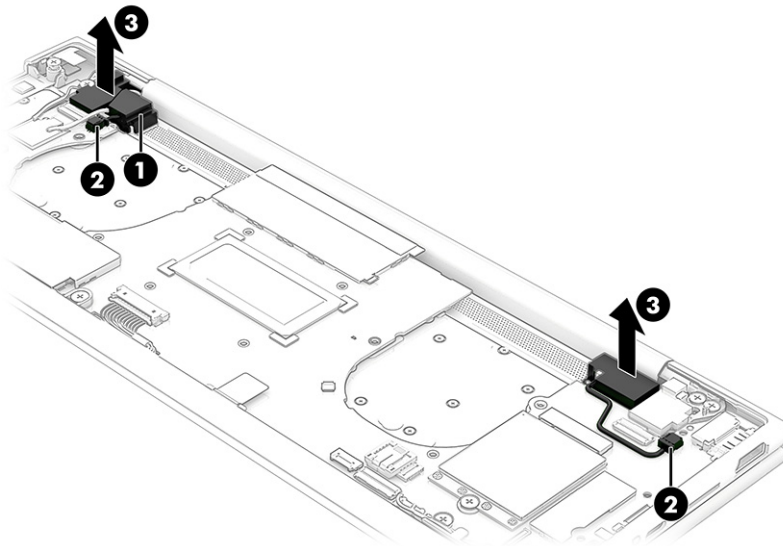

To install the rear speakers, reverse the removal procedures.

System board

To remove the system board, use these procedures and illustrations.

Table 5-9 System board descriptions and part numbers

Description	Spare part number
The system board spare part kit includes an integrated processor, UMA graphics subsystem, and replacement thermal material):	
Equipped with an Intel Core i7-1365U processor, 32 GB of system memory, and the Windows 11 operating system	N46513-601
Equipped with an Intel Core i7-1365U processor, 32 GB of system memory, and a non-Windows operating system	N46513-001
Equipped with an Intel Core i7-1365U processor, 16 GB of system memory, the Windows 11 operating system, for use on computer models equipped with an OLED display assembly	N46511-601
Equipped with an Intel Core i7-1365U processor, 16 GB of system memory, a non-Windows operating system, for use on computer models equipped with an OLED display assembly	N46511-001
Equipped with an Intel Core i7-1365U processor, 16 GB of system memory, OSR, and the Windows 11 operating system	N46512-601
Equipped with an Intel Core i7-1365U processor, 16 GB of system memory, and OSR	N46512-001
Equipped with an Intel Core i7-1365U processor, 16 GB of system memory, and the Windows 11 operating system	N46510-601
Equipped with an Intel Core i7-1365U processor, 16 GB of system memory, and a non-Windows operating system	N46510-001
Equipped with an Intel Core i7-1355U processor, 32 GB of system memory, and the Windows 11 operating system	N46509-601
Equipped with an Intel Core i7-1355U processor, 32 GB of system memory, and a non-Windows operating system	N46509-001

Table 5-9 System board descriptions and part numbers (continued)

Description	Spare part number
Equipped with an Intel Core i7-1355U processor, 16 GB of system memory, the Windows 11 operating system, for use on computer models equipped with an OLED display assembly	N46508-601
Equipped with an Intel Core i7-1355U processor, 16 GB of system memory, a non- Windows operating system, for use on computer models equipped with an OLED display assembly	N46508-001
Equipped with an Intel Core i7-1355U processor, 16 GB of system memory, and the Windows 11 operating system	N46507-601
Equipped with an Intel Core i7-1355U processor, 16 GB of system memory, and a non-Windows operating system	N46507-001
Equipped with an Intel Core i5-1345U processor, 32 GB of system memory, and the Windows 11 operating system	N46506-601
Equipped with an Intel Core i5-1345U processor, 32 GB of system memory, and a non-Windows operating system	N46506-001
Equipped with an Intel Core i5-1345U processor, 16 GB of system memory, OSR, and the Windows 11 operating system	N46505-601
Equipped with an Intel Core i5-1345U processor, 16 GB of system memory, and OSR	N46505-001
Equipped with an Intel Core i5-1345U processor, 16 GB of system memory, and the Windows 11 operating system	N46504-601
Equipped with an Intel Core i5-1345U processor, 16 GB of system memory, and a non-Windows operating system	N46504-001
Equipped with an Intel Core i5-1335U processor, 32 GB of system memory, and the Windows 11 operating system	N46503-601
Equipped with an Intel Core i5-1335U processor, 32 GB of system memory, and a non-Windows operating system	N46503-001
Equipped with an Intel Core i5-1335U processor, 16 GB of system memory, the Windows 11 operating system, for use on computer models equipped with an OLED display assembly	N46502-601
Equipped with an Intel Core i5-1335U processor, 16 GB of system memory, a non- Windows operating system, for use on computer models equipped with an OLED display assembly	N46502-001
Equipped with an Intel Core i5-1335U processor, 16 GB of system memory, and the Windows 11 operating system	N46501-601
Equipped with an Intel Core i5-1335U processor, 16 GB of system memory, and a non-Windows operating system	N46501-001
System Board Repair Support Kit	N19699-888

Before removing the system board, follow these steps:

1. Prepare the computer for disassembly (see [Preparation for disassembly on page 48](#)).
2. Remove the bottom cover (see [Bottom cover on page 48](#)).
3. Disconnect the battery cable from the system board (see [Battery on page 50](#)).
4. Remove the fan/heat sink assembly (see [Fan/heat sink assembly on page 58](#)).

When you replace the system board, be sure to remove the WWAN module (see [WWAN module on page 53](#)) and the solid-state drive (see [Solid-state drive on page 51](#)) from the defective system board and install them on the replacement system board.

Remove the system board:

1. Release the ZIF connector **(1)** the webcam cable is connected to, and then disconnect the webcam cable from the system board.
2. Carefully disconnect the WLAN module antenna cables **(2)** from the WLAN module.

 **NOTE:** Computer models have either one or two WLAN module antennas. On models with two antennas, the #1 white WLAN module antenna cable connects to the WLAN module #1 Main terminal. The #2 black WLAN module antenna cable connects to the WLAN module #1 Aux terminal.

3. Disconnect the rear speaker cables **(3)** from the system board.
4. Carefully disconnect the WWAN module antenna cables **(4)** from the WWAN module.

 **NOTE:** Computer models have one to four WWAN module antenna cables. The antenna cables have tags that identify them with a number that corresponds to a terminal on the WWAN module. Connect the antenna cable to the corresponding WWAN module terminal.

5. Release the ZIF connector **(5)** the display panel cable is connected to, and then disconnect the display panel cable from the system board.
6. Disconnect the following cables from the system board:
 - Transfer board CN320 ZIF cable **(6)**
 - Transfer board D302 ZIF cable **(7)**
 - Fingerprint reader CN320 ZIF cable **(8)**
 - Front speaker cable **(9)**

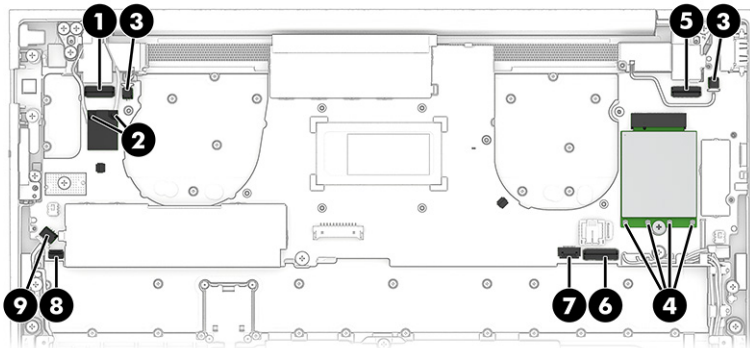

7. Remove the four Phillips M2.0 × 3.9 screws that secure the system board to the computer.

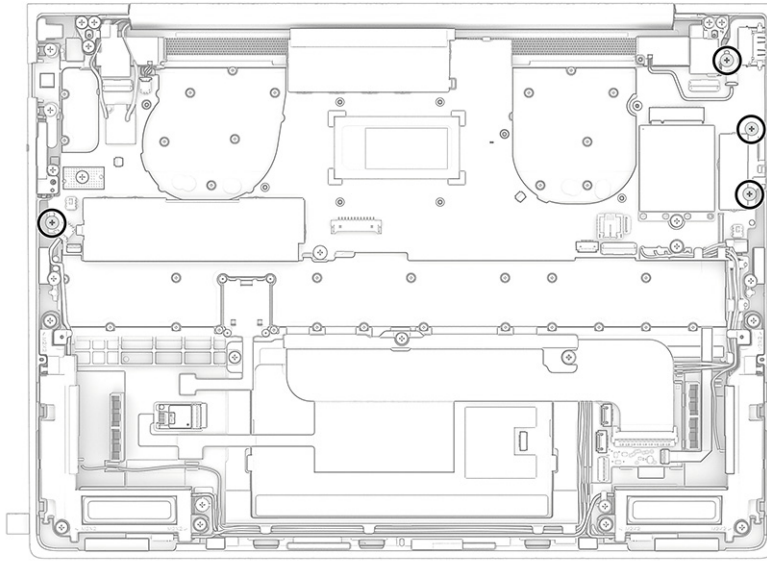

8. Lift the left side of the system board (1) until it rests at an angle.
9. Slide the system board (2) up and to the left at an angle to remove it.

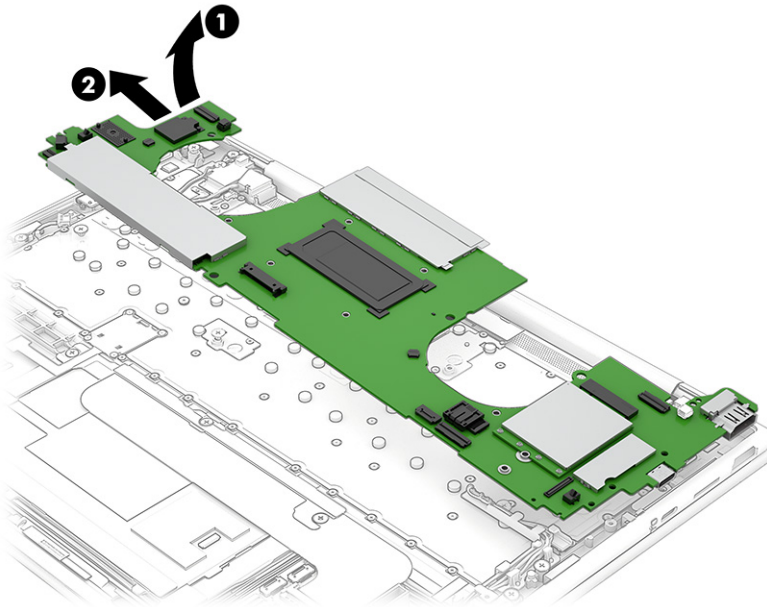

To install the system board, reverse this procedure.

Fingerprint reader cable

To remove the fingerprint reader cable, use this procedure and illustration.

 **NOTE:** The fingerprint reader cable is included in the Cable Kit, spare part number N09288-001.

Before removing the fingerprint reader cable, follow these steps:

1. Prepare the computer for disassembly (see [Preparation for disassembly on page 48](#)).
2. Remove the bottom cover (see [Bottom cover on page 48](#)).
3. Remove the battery (see [Battery on page 50](#)).

Remove the fingerprint reader cable:

1. Detach the fingerprint reader cable (1) from the computer. The fingerprint reader cable is attached to the computer with double-sided tape.
2. Release the ZIF connector (2) the fingerprint reader cable is connected to, and then disconnect the fingerprint reader cable from the system board.
3. Release the ZIF connector (3) the fingerprint reader cable is connected to, and then disconnect the fingerprint reader cable (2) from the fingerprint reader extension cable.

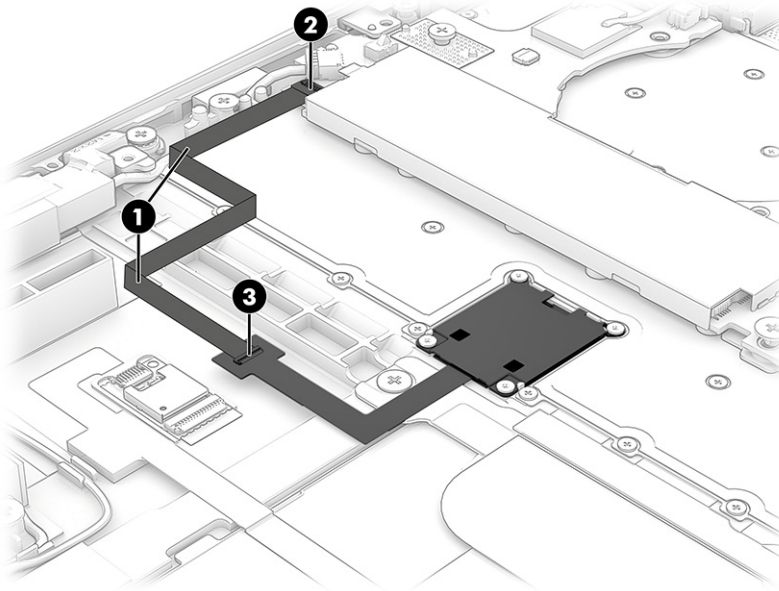

To install the fingerprint reader cable, reverse this procedure.

Fingerprint reader

To remove the fingerprint reader, use this procedure and illustration.

Table 5-10 Fingerprint reader descriptions and part numbers

Description	Spare part number
Fingerprint reader:	
NOTE: The fingerprint reader spare part kit does not include the fingerprint reader cable. The fingerprint reader cable is included in the Cable Kit, spare part number tbd-001.	
In natural silver finish	N53653-001
In slate blue finish	N53652-001

Before removing the fingerprint reader, follow these steps:

1. Prepare the computer for disassembly (see [Preparation for disassembly on page 48](#)).
2. Remove the bottom cover (see [Bottom cover on page 48](#)).
3. Remove the battery (see [Battery on page 50](#)).
4. Remove the fingerprint reader cable (see [Fingerprint reader cable on page 64](#)).

Remove the fingerprint reader:

1. Detach the fingerprint reader extension cable **(1)** from the computer. The fingerprint reader extension cable is attached to the computer with double-sided tape.
2. Remove the four Phillips M1.0 × 1.7 screws **(2)** that secure the fingerprint reader to the computer.
3. Remove the fingerprint reader **(3)** and extension cable.

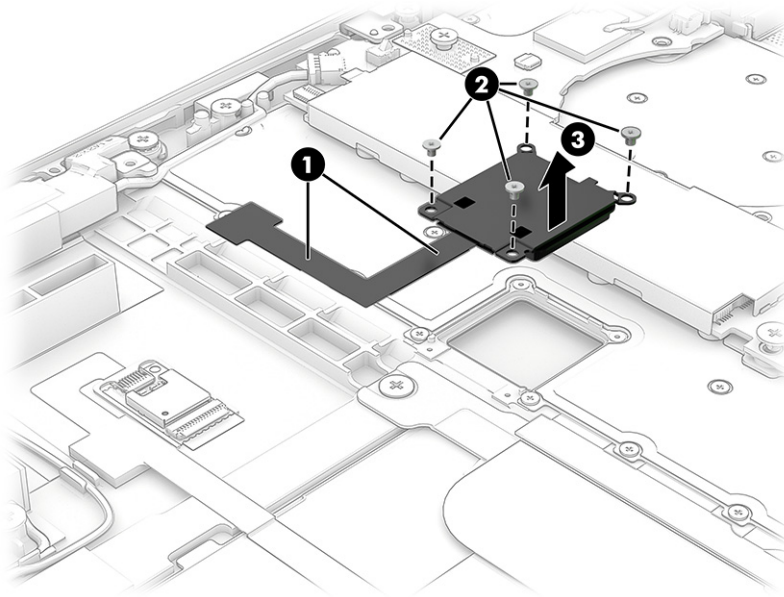

To install the fingerprint reader, reverse this procedure.

Touchpad cable

To remove the touchpad cable, use this procedure and illustration.

 **NOTE:** The touchpad cable is included in the Cable Kit, spare part number tbd-001.

Before removing the touchpad cable, follow these steps:

1. Prepare the computer for disassembly (see [Preparation for disassembly on page 48](#)).
2. Remove the bottom cover (see [Bottom cover on page 48](#)).
3. Remove the battery (see [Battery on page 50](#)).

Remove the touchpad cable:

1. Release the ZIF connector **(1)** the touchpad cable is connected to, and then disconnect the touchpad cable from the transfer board.

2. Release the ZIF connector **(2)** the touchpad cable is connected to, and then disconnect the touchpad cable from the touchpad.
3. Remove the touchpad cable **(3)** from the computer.

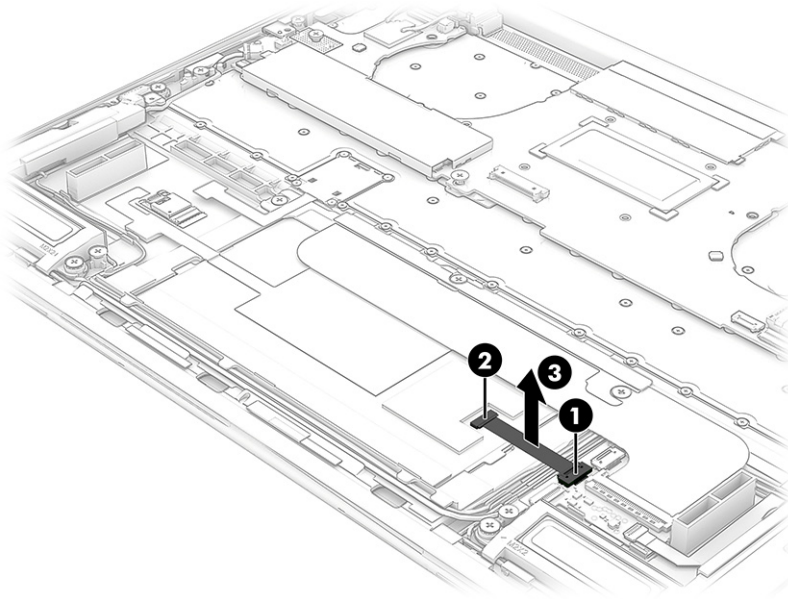

To install the touchpad cable, reverse this procedure.

Touchpad

To remove the touchpad, use this procedure and illustration.

 **NOTE:** The touchpad spare part kit includes touchpad.

Table 5-11 Touchpad descriptions and part numbers

Description	Spare part number
Touchpad:	
In natural silver finish	N08577-001
In slate blue finish	N08578-001

NOTE: The touchpad spare part kit does not include the touchpad cable. The touchpad cable is included in the Cable Kit, spare part number tbd-001.

Before removing the touchpad, follow these steps:

1. Prepare the computer for disassembly (see [Preparation for disassembly on page 48](#)).
2. Remove the bottom cover (see [Bottom cover on page 48](#)).
3. Remove the battery (see [Battery on page 50](#)).
4. Remove the touchpad cable (see [Touchpad cable on page 66](#)).

Remove the touchpad:

1. Detach the NFC antenna cable **(1)** from the computer. The NFC antenna cable is attached to the computer with double-sided adhesive.
2. Release the ZIF connector **(2)** the NFC antenna cable is connected to, and then disconnect the NFC antenna cable from the NFC module.
3. Release the ZIF connector **(3)** the keyboard cable is connected to, and then disconnect the keyboard cable from the transfer board.
4. Fold back the keyboard cable **(4)** to allow access to the touchpad screws.
5. Remove the three Phillips PM2.0 × 2.3 broadhead screws **(5)** that secure the touchpad to the computer.
6. Lift the rear edge of the touchpad **(6)** until it rests at an angle.
7. Remove the touchpad **(7)** by sliding it up and back at an angle.

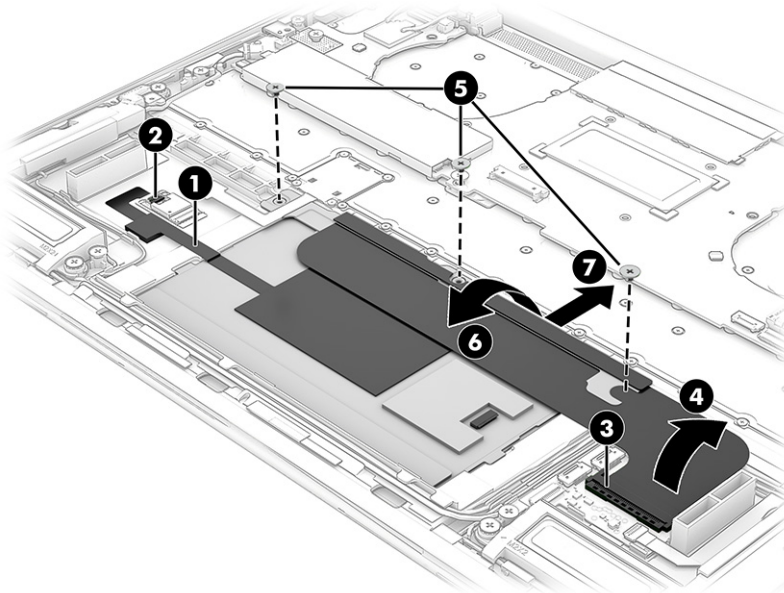

To install the touchpad, reverse this procedure.

Transfer board cable

To remove the transfer board cable, use this procedure and illustration.



NOTE: The transfer board cable is included in the Cable Kit, spare part number tbd-001.

Before removing the transfer board cable, follow these steps:

1. Prepare the computer for disassembly (see [Preparation for disassembly on page 48](#)).
2. Remove the bottom cover (see [Bottom cover on page 48](#)).
3. Remove the battery (see [Battery on page 50](#)).

Remove the transfer board cable:

1. Release the ZIF connector **(1)** the keyboard cable is connected to, and then disconnect the keyboard cable from the transfer board.

2. Fold back the keyboard cable (2) to allow access to the transfer board.
3. Release the ZIF connectors (3) the transfer board cables are connected to, and then disconnect the transfer board cables from the system board.
4. Release the ZIF connectors (4) the transfer board cables are connected to, and then disconnect the transfer board cables from the transfer board.
5. Detach the transfer board cables (5) from the computer. The transfer board cables are attached to the computer with double-sided adhesive.

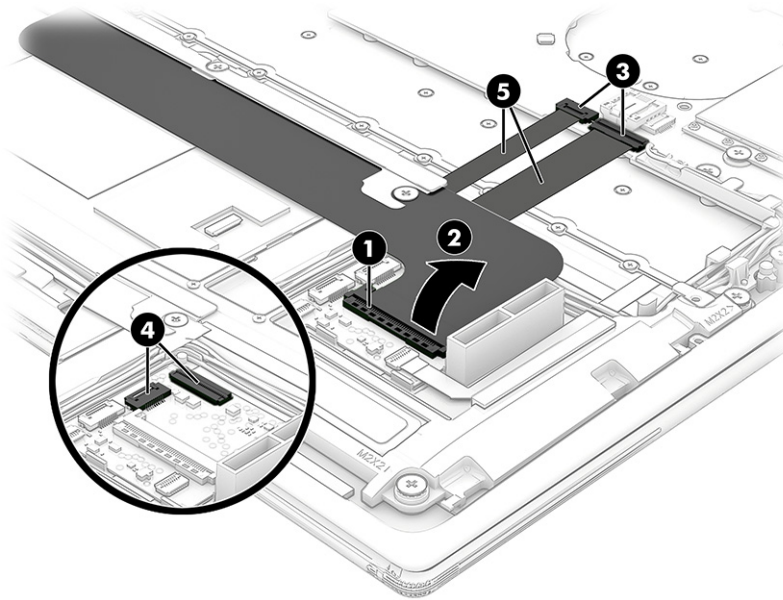

6. Remove the transfer board cables.

To install the transfer board cables, reverse this procedure.

Transfer board

To remove the transfer board, use this procedure and illustration.

 **NOTE:** The transfer board spare part kit includes transfer board.

Table 5-12 Transfer board description and part number

Description	Spare part number
transfer board	N11563-001

NOTE: The transfer board spare part kit does not include the transfer board cable. The transfer board cable is included in the Cable Kit, spare part number tbd-001.

Before removing the transfer board, follow these steps:

1. Prepare the computer for disassembly (see [Preparation for disassembly on page 48](#)).
2. Remove the bottom cover (see [Bottom cover on page 48](#)).
3. Remove the battery (see [Battery on page 50](#)).

4. Remove the transfer board cable (see [Transfer board cable on page 68](#)).

Remove the transfer board:

1. Release the ZIF connector **(1)** the touchpad cable is connected to, and then disconnect the touchpad cable from the transfer board.
2. Release the ZIF connector **(2)** the NFC module cable is connected to, and then disconnect the NFC module cable from the transfer board.
3. Release the ZIF connector **(3)** the backlight cable is connected to, and then disconnect the backlight cable from the transfer board.
4. Remove the transfer board **(4)**.

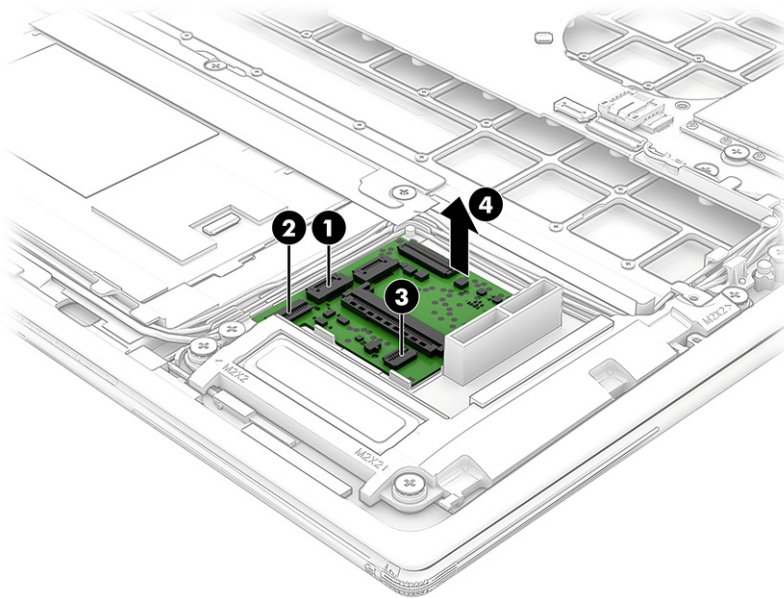

To install the transfer board, reverse this procedure.

NFC module cable

To remove the NFC module cable, use this procedure and illustration.



NOTE: The NFC module cable is included in the Cable Kit, spare part number tbd-001.

Before removing the NFC module cable, follow these steps:

1. Prepare the computer for disassembly (see [Preparation for disassembly on page 48](#)).
2. Remove the bottom cover (see [Bottom cover on page 48](#)).
3. Remove the battery (see [Battery on page 50](#)).

Remove the NFC module cable:

1. Release the ZIF connector **(1)** the NFC module cable is connected to, and then disconnect the NFC module cable from the transfer board.

2. Detach the NFC module cable (2) from the computer. The NFC module cable is attached to the computer with double-sided adhesive.

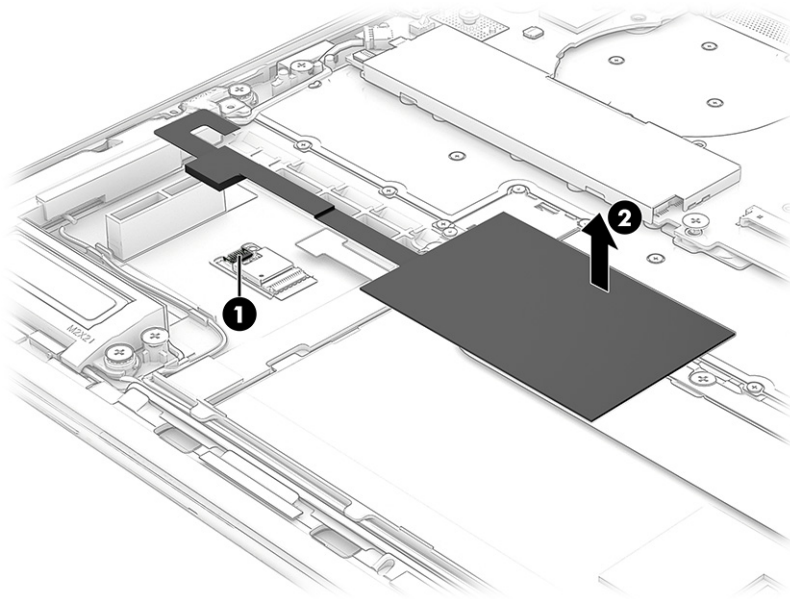

3. Remove the NFC module cable.

To install the NFC module cable, reverse this procedure.

NFC module

To remove the NFC module, use this procedure and illustration.

Table 5-13 NFC module description and part number

Description	Spare part number
NFC module	M08706-001

NOTE: The NFC module spare part kit does not include the NFC module cable. The NFC module cable is included in the Cable Kit, spare part number tbd-001.

Before removing the NFC module, follow these steps:

1. Prepare the computer for disassembly (see [Preparation for disassembly on page 48](#)).
2. Remove the bottom cover (see [Bottom cover on page 48](#)).
3. Remove the battery (see [Battery on page 50](#)).
4. Remove the NFC module cable (see [NFC module cable on page 70](#)).

Remove the NFC module:

1. Detach the NFC module from the computer. The NFC module is attached to the computer with double-sided adhesive.

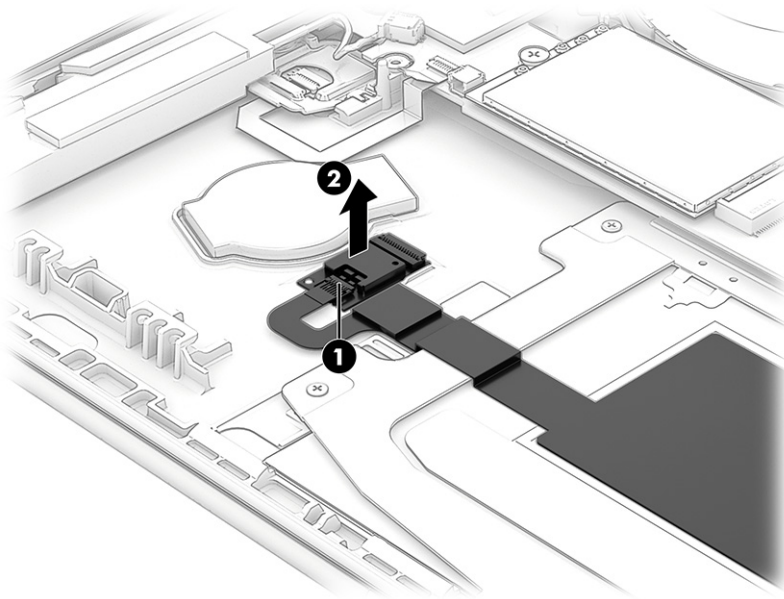

2. Remove the NFC module.

To install the NFC module, reverse this procedure.

WWAN antenna

To remove the WWAN antenna, use this procedure and illustration.

 **NOTE:** The WWAN antenna is included in the WWAN Cable Kit, spare part number N11558-001.

Before removing the WWAN antenna, follow these steps:

1. Prepare the computer for disassembly (see [Preparation for disassembly on page 48](#)).
2. Remove the bottom cover (see [Bottom cover on page 48](#)).
3. Remove the battery (see [Battery on page 50](#)).

Remove the WWAN antenna:

1. Carefully disconnect the WWAN module antenna cables **(1)** from the WWAN module.

 **NOTE:** Computer models have one to four WWAN module antenna cables. The antenna cables have tags that identify them with a number that corresponds to a terminal on the WWAN module. Connect the antenna cable to the corresponding WWAN module terminal.

2. Release the WWAN antenna cables from the retention clips **(2)** that are built into the computer.

3. Detach the WWAN antenna transceivers **(3)** from the computer. The WWAN antenna transceivers are attached to the computer with double-sided adhesive.

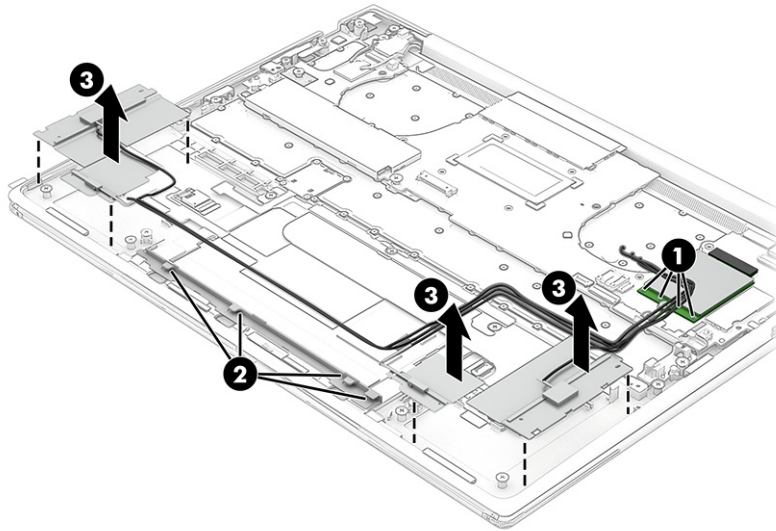

4. Remove the WWAN antenna cables and transceivers.

To install the WWAN antenna cables and transceivers, reverse this procedure.

Front speakers

To remove the front speakers, use this procedure and illustration.

Table 5-14 Front speakers description and part number

Description	Spare part number
Front speakers (included in the Speaker Kit; includes left and right front speakers, cables, and six rubber isolators)	N08563-001

Before removing the front speakers, follow these steps:

1. Prepare the computer for disassembly (see [Preparation for disassembly on page 48](#)).
2. Remove the bottom cover (see [Bottom cover on page 48](#)).
3. Remove the battery (see [Battery on page 50](#)).

Remove the front speakers:

1. Disconnect the front speaker cable **(1)** from the system board.
2. Remove the six Phillips M2.0 × 2.3 broadhead screws **(2)** that secure the front speakers to the computer.
3. Remove the front speakers **(3)** from the computer.

When removing the front speakers, make note of the location of the six rubber isolator locations **(4)**. The absence of or damage to these isolators can result in degraded speaker performance.

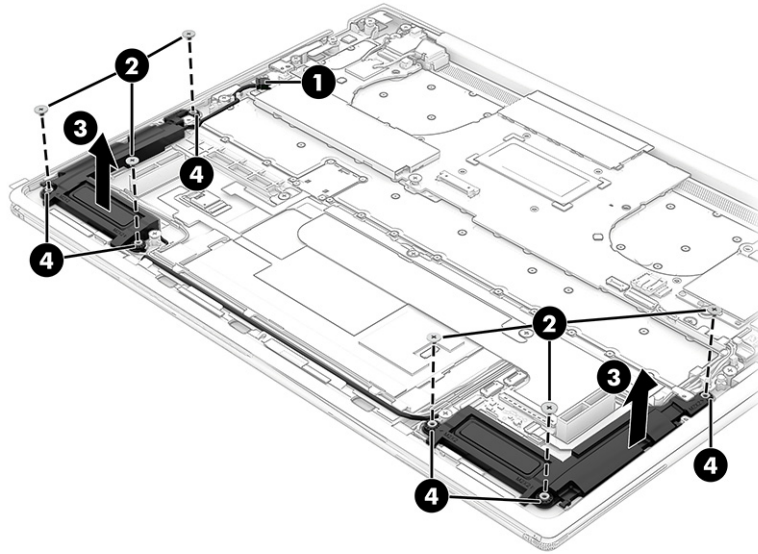

To install the front speakers, reverse the removal procedures.

Top cover with keyboard

The top cover with keyboard remains after removing all other spare parts from the computer. In this section, the first table provides the main spare part numbers for the top cover with keyboards. The second table provides the country codes.

Table 5-15

Description	Spare part number
Top cover with keyboard in natural silver finish, backlit and spill-resistant for use on computer models equipped with WWAN capability and a display assembly with privacy filter (includes backlight cable and keyboard cable)	N08586-xxx
Top cover with keyboard in natural silver finish, backlit and spill-resistant for use on computer models equipped with a display assembly with privacy filter (includes backlight cable and keyboard cable)	N08584-xxx
Top cover with keyboard in natural silver finish, backlit and spill-resistant for use on computer models equipped with WWAN capability (includes backlight cable and keyboard cable)	N08585-xxx
Top cover with keyboard in natural silver finish, backlit and spill-resistant (includes backlight cable and keyboard cable)	N08583-xxx
Top cover with keyboard in slate blue finish, backlit and spill-resistant for use on computer models equipped with WWAN capability and a display assembly with privacy filter (includes backlight cable and keyboard cable)	N08582-xxx
Top cover with keyboard in slate blue finish, backlit and spill-resistant for use on computer models equipped with a display assembly with privacy filter (includes backlight cable and keyboard cable)	N08580-xxx
Top cover with keyboard in slate blue finish, backlit and spill-resistant for use on computer models equipped with WWAN capability (includes backlight cable and keyboard cable)	N08581-xxx
Top cover with keyboard in slate blue finish, backlit and spill-resistant (includes backlight cable and keyboard cable)	N08579-xxx

Table 5-16 Spare part country codes

For use in country or region	Country code	For use in country or region	Country code	For use in country or region	Country code
Belgium	-A41	Israel	-BB1	Slovenia	-BA1
Brazil	-201	Italy	-061	South Korea	-AD1
Bulgaria	-261	Japan	-291	Spain	-071
The Czech Republic and Slovakia	-FL1	Kazakhstan	-DF1	Sweden and Finland	-B71
Denmark	-081	Latin America	-161	Switzerland	-BG1
Denmark, Finland, and Norway	-DH1	The Netherlands	-B31	Taiwan	-AB1
France	-051	North Africa	-FP1	Thailand	-281
French Canada	-DB1	Norway	-091	Turkey	-141
Germany	-041	Portugal	-131	Turkey-F	-541
Greece	-151	Romania	-271	Ukraine	-BD1
Hungary	-211	Russia	-251	United Kingdom	-031
Iceland	-DD1	Saudi Arabia	-171	United States	-001
India	-D61				

6 Computer Setup (BIOS), TPM, and HP Sure Start

HP provides several tools to help set up and protect your computer.

Using Computer Setup

Computer Setup, or Basic Input/Output System (BIOS), controls communication between all the input and output devices on the system (such as hard drives, display, keyboard, mouse, and printer). Computer Setup includes settings for types of devices installed, the startup sequence of the computer, and amount of system and extended memory.

 **NOTE:** Use extreme care when making changes in Computer Setup. Errors can prevent the computer from operating properly.

To start Computer Setup, turn on or restart the computer, and when the HP logo appears, press **f10** to enter Computer Setup.

Navigating and selecting in Computer Setup

You can navigate and select in Computer Setup using one or more methods.

- To select a menu or a menu item, use the **tab** key and the keyboard arrow keys and then press **enter**, or use a pointing device to select the item.
- To scroll up and down, select the up arrow or the down arrow in the upper-right corner of the screen, or use the up arrow key or the down arrow key on the keyboard.
- To close open dialog boxes and return to the main Computer Setup screen, press **esc**, and then follow the on-screen instructions.

To exit Computer Setup, choose one of the following methods:

- To exit Computer Setup menus without saving your changes, select **Main**, select **Ignore Changes and Exit**, and then select **Yes**.

 **NOTE:** If you are using arrow keys to highlight your choice, you must then press **enter**.

- To save your changes and exit Computer Setup menus, select **Main**, select **Save Changes and Exit**, and then select **Yes**.

 **NOTE:** If you are using arrow keys to highlight your choice, you must then press **enter**.

Your changes go into effect when the computer restarts.

Restoring factory settings in Computer Setup

To return all settings in Computer Setup to the values that were set at the factory, follow these steps.

 **NOTE:** Restoring defaults will not change the hard drive mode.

1. Start Computer Setup. See [Using Computer Setup on page 76](#).
2. Select **Main**, select **Apply Factory Defaults and Exit**, and then select **Yes**.

 **NOTE:** If you are using arrow keys to highlight your choice, you must then press [enter](#).

 **NOTE:** On select products, the selections might display **Restore Defaults** instead of **Apply Factory Defaults and Exit**.

Your changes go into effect when the computer restarts.

 **NOTE:** Your password settings and security settings are not changed when you restore the factory settings.

Updating the BIOS

Updated versions of the BIOS might be available on the HP website. Most BIOS updates on the HP website are packaged in compressed files called *SoftPaqs*.

Some download packages contain a file named *Readme.txt*, which contains information regarding installing and troubleshooting the file.

Determining the BIOS version

To decide whether you need to update Computer Setup (BIOS), first determine the BIOS version on your computer.

If you are already in Windows, you can access BIOS version information (also known as *ROM date* and *System BIOS*) by pressing **fn+esc** (select products only). Or you can use Computer Setup.

1. Start Computer Setup. See [Using Computer Setup on page 76](#).
2. Select **Main**, and then select **System Information**.
3. To exit Computer Setup menus without saving your changes, select **Main**, select **Ignore Changes and Exit**, and then select **Yes**.

 **NOTE:** If you are using arrow keys to highlight your choice, you must then press [enter](#).

To check for later BIOS versions, see [Preparing for a BIOS update on page 77](#).

Preparing for a BIOS update

Be sure to follow all prerequisites before downloading and installing a BIOS update.

 **IMPORTANT:** To reduce the risk of damage to the computer or an unsuccessful installation, download and install a BIOS update only when the computer is connected to reliable external power using the AC adapter. Do not download or install a BIOS update while the computer is running on battery power, docked in an optional docking device, or connected to an optional power source. During the download and installation, follow these instructions:

Do not disconnect power on the computer by unplugging the power cord from the AC outlet.

Do not shut down the computer or initiate Sleep.

Do not insert, remove, connect, or disconnect any device, cable, or cord.

Downloading a BIOS update

After you review the prerequisites, you can check for and download BIOS updates.

1. Select the **Search** icon in the taskbar, type `support` in the search box, and then select the **HP Support Assistant** app.

- or -
Select the question mark icon (select products only) in the taskbar.
2. Select **Updates**, and then select **Check for updates and messages**.
3. Follow the on-screen instructions.
4. At the download area, follow these steps:
 - a. Identify the most recent BIOS update and compare it to the BIOS version currently installed on your computer. Make a note of the date, name, or other identifier. You might need this information to locate the update later, after it has been downloaded to your hard drive.
 - b. Follow the on-screen instructions to download your selection to the hard drive.

Make a note of the path to the location on your hard drive where the BIOS update is downloaded. You will need to access this path when you are ready to install the update.



NOTE: If you connect your computer to a network, consult the network administrator before installing any software updates, especially system BIOS updates.

Installing a BIOS update

BIOS installation procedures vary. Follow any instructions that are displayed on the screen after the download is complete. If no instructions are displayed, follow these steps.

1. Select the **Search** icon in the taskbar, type `file` in the search box, and then select **File Explorer**.
2. Select your hard drive designation. The hard drive designation is typically Local Disk (C:).
3. Using the hard drive path you recorded earlier, open the folder that contains the update.
4. Double-click the file that has an `.exe` extension (for example, `filename.exe`).

The BIOS installation begins.
5. Complete the installation by following the on-screen instructions.



NOTE: After a message on the screen reports a successful installation, you can delete the downloaded file from your hard drive.

Changing the boot order using the f9 prompt

To dynamically choose a boot device for the current startup sequence, follow these steps.

1. Access the Boot Device Options menu:
 - Turn on or restart the computer, and when the HP logo appears, press **f9** to enter the Boot Device Options menu.
2. Select a boot device, press **enter**, and then follow the on-screen instructions.

TPM BIOS settings (select products only)

TPM provides additional security for your computer. You can modify the TPM settings in Computer Setup (BIOS).

 **IMPORTANT:** Before enabling Trusted Platform Module (TPM) functionality on this system, you must ensure that your intended use of TPM complies with relevant local laws, regulations and policies, and approvals or licenses must be obtained if applicable. For any compliance issues arising from your operation or usage of TPM that violates the previously mentioned requirement, you shall bear all the liabilities wholly and solely. HP will not be responsible for any related liabilities.

 **NOTE:** If you change the TPM setting to Hidden, TPM is not visible in the operating system.

To access TPM settings in Computer Setup:

1. Start Computer Setup. See [Using Computer Setup on page 76](#).
2. Select **Security**, select **TPM Embedded Security**, and then follow the on-screen instructions.

Using HP Sure Start (select products only)

Select computer models are configured with HP Sure Start, a technology that monitors the computer's BIOS for attacks or corruption. If the BIOS becomes corrupted or is attacked, HP Sure Start automatically restores the BIOS to its previously safe state, without user intervention.

HP Sure Start is configured and already enabled so that most users can use the HP Sure Start default configuration. Advanced users can customize the default configuration.

To access the latest documentation on HP Sure Start, go to <http://www.hp.com/support>. Select **Find your product**, and then follow the on-screen instructions.

7 Backing up, restoring, and recovering

You can use Windows tools or HP software to back up your information, create a restore point, reset your computer, create recovery media, or restore your computer to its factory state. Performing these standard procedures can return your computer to a working state faster.

 **IMPORTANT:** If you are performing recovery procedures on a tablet, the tablet battery must be at least 70% charged before you start the recovery process.

 **IMPORTANT:** For a tablet with a detachable keyboard, connect the tablet to the keyboard base before beginning any recovery process.

Backing up information and creating recovery media

These methods of creating recovery media and backups are available on select products only.

Using Windows tools for backing up

HP recommends that you back up your information immediately after initial setup. You can do this task either using Windows Backup locally with an external USB flash drive or using online tools.

 **NOTE:** If computer storage is 32 GB or less, Microsoft® System Restore is disabled by default.

Using the HP Cloud Recovery Download Tool to create recovery media (select products only)

You can use the HP Cloud Recovery Download Tool to create HP Recovery media on a bootable USB flash drive.

For details:

- Go to <http://www.hp.com>, search for HP Cloud Recovery, and then select the result that matches the type of computer that you have.

 **NOTE:** If you cannot create recovery media yourself, contact support to obtain recovery discs. Go to <http://www.hp.com/support>, select your country or region, and then follow the on-screen instructions.

 **IMPORTANT:** HP recommends that you follow the [Restoring and recovery methods on page 81](#) to restore your computer before you obtain and use the HP recovery discs. Using a recent backup can return your machine to a working state sooner than using the HP recovery discs. After the system is restored, reinstalling all the operating system software released since your initial purchase can be a lengthy process.

Restoring and recovering your system

You have several tools available to recover your system both within and outside of Windows if the desktop cannot load.

HP recommends that you attempt to restore your system using the [Restoring and recovery methods on page 81](#).

Creating a system restore

System Restore is available in Windows. The System Restore software can automatically or manually create restore points, or snapshots, of the system files and settings on the computer at a particular point.

When you use System Restore, it returns your computer to its state at the time you made the restore point. Your personal files and documents should not be affected.

Restoring and recovery methods

After you run the first method, test to see whether the issue still exists before you proceed to the next method, which might now be unnecessary.

1. Run a Microsoft System Restore.
2. Run Reset this PC.



NOTE: The options **Remove everything** and then **Fully clean the drive** can take several hours to complete and leave no information on your computer. It is the safest way to reset your computer before you recycle it.

3. Recover using HP Recovery media. For more information, see [Recovering using HP Recovery media on page 81](#).

For more information about the first two methods, see the Get Help app:

- Select the **Start** button, select **All apps**, select the **Get Help** app, and then enter the task you want to perform.



NOTE: You must be connected to the internet to access the Get Help app.

Recovering using HP Recovery media

You can use HP Recovery media to recover the operating system and drivers that were installed at the factory. On select products, you can create recovery media on a bootable USB flash drive using the HP Cloud Recovery Download Tool.

For details, see [Using the HP Cloud Recovery Download Tool to create recovery media \(select products only\) on page 80](#).



NOTE: If you cannot create recovery media yourself, contact support to obtain recovery discs. Go to <http://www.hp.com/support>, select your country or region, and then follow the on-screen instructions.

To recover your system:

- Insert the HP Recovery media, and then restart the computer.

 **NOTE:** HP recommends that you follow the [Restoring and recovery methods on page 81](#) to restore your computer before you obtain and use the HP recovery discs. Using a recent backup can return your machine to a working state sooner than using the HP recovery discs. After the system is restored, reinstalling all the operating system software released since your initial purchase can be a lengthy process.

Changing the computer boot order

If your computer does not restart using the HP Recovery media, you can change the computer boot order, which is the order of devices listed in BIOS for startup information. You can select an optical drive or a USB flash drive, depending on the location of your HP Recovery media.

 **IMPORTANT:** For a tablet with a detachable keyboard, connect the tablet to the keyboard base before beginning these steps.

To change the boot order:

1. Insert the HP Recovery media.
2. Access the system **Startup** menu.
 - For computers or tablets with keyboards attached, turn on or restart the computer or tablet, quickly press **esc**, and then press **f9** for boot options.
 - For tablets without keyboards, turn on or restart the tablet, quickly press and hold the volume up button, and then select **f9**.

– or –

Turn on or restart the tablet, quickly press and hold the volume down button, and then select **f9**.
3. Select the optical drive or USB flash drive from which you want to boot, and then follow the on-screen instructions.

Using HP Sure Recover (select products only)

Select computer models are configured with HP Sure Recover, a PC operating system (OS) recovery solution built into the hardware and software. HP Sure Recover can fully restore the HP OS image without installed recovery software.

Using HP Sure Recover, an administrator or user can restore the system and install:

- Latest version of the operating system
- Platform-specific device drivers
- Software applications, in the case of a custom image

To access the latest documentation for HP Sure Recover, go to <http://www.hp.com/support>. Follow the on-screen instructions to find your product and locate your documentation.

8 Using HP PC Hardware Diagnostics

You can use the HP PC Hardware Diagnostics utility to determine whether your computer hardware is running properly. The three versions are HP PC Hardware Diagnostics Windows, HP PC Hardware Diagnostics UEFI (Unified Extensible Firmware Interface), and (for select products only) Remote HP PC Hardware Diagnostics UEFI, a firmware feature.

Using HP PC Hardware Diagnostics Windows (select products only)

HP PC Hardware Diagnostics Windows is a Windows-based utility that allows you to run diagnostic tests to determine whether the computer hardware is functioning properly. The tool runs within the Windows operating system to diagnose hardware failures.

If HP PC Hardware Diagnostics Windows is not installed on your computer, you must download and install it. To download HP PC Hardware Diagnostics Windows, see [Downloading HP PC Hardware Diagnostics Windows on page 84](#).

Using an HP PC Hardware Diagnostics Windows hardware failure ID code

When HP PC Hardware Diagnostics Windows detects a failure that requires hardware replacement, a 24-digit failure ID code is generated for select component tests. For interactive tests, such as keyboard, mouse, or audio and video palette, you must perform troubleshooting steps before you can receive a failure ID.

- You have several options after you receive a failure ID:
 - Select **Next** to open the Event Automation Service (EAS) page, where you can log the case.
 - Scan the QR code with your mobile device, which takes you to the EAS page, where you can log the case.
 - Select the box next to the 24-digit failure ID to copy your failure code and send it to support.

Accessing HP PC Hardware Diagnostics Windows

After HP PC Hardware Diagnostics Windows is installed, you can access it from HP Support Assistant or the Start menu.

Accessing HP PC Hardware Diagnostics Windows from HP Support Assistant

After HP PC Hardware Diagnostics Windows is installed, follow these steps to access it from HP Support Assistant:

1. Complete one of the following tasks:
 - Select the **Search** icon in the taskbar, type `support` in the search box, and then select the **HP Support Assistant** app.
 - Select the question mark icon in the taskbar.
2. Select **Fixes & Diagnostics**.
3. Select **Run hardware diagnostics**, and then select **Launch**.
4. When the tool opens, select the type of diagnostic test that you want to run, and then follow the on-screen instructions.



NOTE: To stop a diagnostic test, select **Cancel**.

Accessing HP PC Hardware Diagnostics Windows from the Start menu (select products only)

After HP PC Hardware Diagnostics Windows is installed, follow these steps to access it from the Start menu:

1. Select the **Start** button, and then select **All apps**.
2. Select **HP PC Hardware Diagnostics Windows**.
3. When the tool opens, select the type of diagnostic test that you want to run, and then follow the on-screen instructions.



NOTE: To stop a diagnostic test, select **Cancel**.

Downloading HP PC Hardware Diagnostics Windows

The HP PC Hardware Diagnostics Windows downloading instructions are provided in English only. You must use a Windows computer to download this tool because only .exe files are provided.

Downloading the latest HP PC Hardware Diagnostics Windows version from HP

To download HP PC Hardware Diagnostics Windows from HP, follow these steps:

1. Go to <http://www.hp.com/go/techcenter/pcdiags>. The HP PC Diagnostics home page is displayed.
2. Select **Download HP Diagnostics Windows**, and then select the specific Windows diagnostics version to download to your computer or a USB flash drive.

The tool downloads to the selected location.

Downloading the HP PC Hardware Diagnostics Windows from the Microsoft Store

You can download the HP PC Hardware Diagnostics Windows from the Microsoft Store:

1. Select the Microsoft Store app on your desktop or select the **Search** icon in the taskbar, and then type `Microsoft Store` in the search box.
2. Type `HP PC Hardware Diagnostics Windows` in the **Microsoft Store** search box.
3. Follow the on-screen directions.

The tool downloads to the selected location.

Downloading HP Hardware Diagnostics Windows by product name or number (select products only)

You can download HP PC Hardware Diagnostics Windows by product name or number.

 **NOTE:** For some products, you might have to download the software to a USB flash drive by using the product name or number.

1. Go to <http://www.hp.com/support>.
2. Select **Software and Drivers**, select your type of product, and then enter the product name or number in the search box that is displayed.
3. In the **Diagnostics** section, select **Download**, and then follow the on-screen instructions to select the specific Windows diagnostics version to be downloaded to your computer or USB flash drive.

The tool downloads to the selected location.

Installing HP PC Hardware Diagnostics Windows

To install HP PC Hardware Diagnostics Windows, navigate to the folder on your computer or the USB flash drive where the .exe file downloaded, double-click the .exe file, and then follow the on-screen instructions.

Using HP PC Hardware Diagnostics UEFI

HP PC Hardware Diagnostics Unified Extensible Firmware Interface (UEFI) allows you to run diagnostic tests to determine whether the computer hardware is functioning properly. The tool runs outside the operating system so that it can isolate hardware failures from issues that are caused by the operating system or other software components.

 **NOTE:** For some products, you must use a Windows computer and a USB flash drive to download and create the HP UEFI support environment because only .exe files are provided. For more information, see [Downloading HP PC Hardware Diagnostics UEFI to a USB flash drive on page 86](#).

If your PC does not start in Windows, you can use HP PC Hardware Diagnostics UEFI to diagnose hardware issues.

Using an HP PC Hardware Diagnostics UEFI hardware failure ID code

When HP PC Hardware Diagnostics UEFI detects a failure that requires hardware replacement, a 24-digit failure ID code is generated.

For assistance in solving the problem, complete one of these tasks:

- Select **Contact HP**, accept the HP privacy disclaimer, and then use a mobile device to scan the failure ID code that appears on the next screen. The HP Customer Support - Service Center page appears with your failure ID and product number automatically filled in. Follow the on-screen instructions.
- Contact support, and provide the failure ID code.

Starting HP PC Hardware Diagnostics UEFI

To start HP PC Hardware Diagnostics UEFI, follow this procedure.

1. Turn on or restart the computer, and quickly press **esc**.
2. Press **f2**.

The BIOS searches three places for the diagnostic tools, in the following order:

- a. Connected USB flash drive



NOTE: To download the HP PC Hardware Diagnostics UEFI tool to a USB flash drive, see [Downloading the latest HP PC Hardware Diagnostics UEFI version on page 87](#).

- b. Hard drive

- c. BIOS

3. When the diagnostic tool opens, select the type of diagnostic test that you want to run, and then follow the on-screen instructions.

Starting HP PC Hardware Diagnostics UEFI through HP Hotkey Support software (select products only)

This section describes how to start HP PC Hardware Diagnostics UEFI through HP Hotkey Support software.



NOTE: You must disable fast boot to access HP PC Hardware Diagnostics UEFI from the HP System Information application. To disable fast boot:

1. Turn on or restart the computer, and when the HP logo appears, press **f10** to enter Computer Setup.
2. Select **Advanced**, and then select **Boot Options**.
3. Clear **Fast Boot**.
4. Select **Save Changes and Exit**, and then select **Yes**.

1. From the **Start** menu, open the HP System Information Application or enter **fn+esc**.
2. In HP System Information screen, select **Run System Diagnostics**, select **Yes** to run the application, and then select **Restart**.



IMPORTANT: To prevent loss of data, save your work in all open apps before restarting your computer.



NOTE: When the restart is complete, the computer will boot to HP PC Hardware Diagnostics UEFI Application. Proceed with the troubleshooting tests.

Downloading HP PC Hardware Diagnostics UEFI to a USB flash drive

Downloading HP PC Hardware Diagnostics UEFI to a USB flash drive can be useful in some situations.

- HP PC Hardware Diagnostics UEFI is not included in the preinstallation image.
- HP PC Hardware Diagnostics UEFI is not included in the HP Tool partition.
- The hard drive is damaged.



NOTE: The HP PC Hardware Diagnostics UEFI downloading instructions are provided in English only, and you must use a Windows computer to download and create the HP UEFI support environment because only .exe files are provided.

Downloading the latest HP PC Hardware Diagnostics UEFI version

To download the latest HP PC Hardware Diagnostics UEFI version to a USB flash drive, follow this procedure:

1. Go to <http://www.hp.com/go/techcenter/pcdiags>. The HP PC Diagnostics home page is displayed.
2. Select **Download HP Diagnostics UEFI**, and then select **Run**.

Downloading HP PC Hardware Diagnostics UEFI by product name or number (select products only)

You can download HP PC Hardware Diagnostics UEFI by product name or number (select products only) to a USB flash drive.



NOTE: For some products, you might have to download the software to a USB flash drive by using the product name or number.

1. Go to <http://www.hp.com/support>.
2. Enter the product name or number, select your computer, and then select your operating system.
3. In the **Diagnostics** section, follow the on-screen instructions to select and download the specific UEFI Diagnostics version for your computer.

Using Remote HP PC Hardware Diagnostics UEFI settings (select products only)

Remote HP PC Hardware Diagnostics UEFI is a firmware (BIOS) feature that downloads HP PC Hardware Diagnostics UEFI to your computer. It can then run the diagnostics on your computer, and it might upload results to a preconfigured server.

For more information about Remote HP PC Hardware Diagnostics UEFI, go to <http://www.hp.com/go/techcenter/pcdiags>, and then select **Find out more**.

Downloading Remote HP PC Hardware Diagnostics UEFI

Remote HP PC Hardware Diagnostics UEFI is also available as a SoftPaq that you can download to a server.

Downloading the latest Remote HP PC Hardware Diagnostics UEFI version

You can download the latest Remote HP PC Hardware Diagnostics UEFI version to a USB flash drive.

1. Go to <http://www.hp.com/go/techcenter/pcdiags>. The HP PC Diagnostics home page is displayed.
2. Select **Download Remote Diagnostics**, and then select **Run**.

Downloading Remote HP PC Hardware Diagnostics UEFI by product name or number

You can download Remote HP PC Hardware Diagnostics UEFI by product name or number.



NOTE: For some products, you might have to download the software by using the product name or number.

1. Go to <http://www.hp.com/support>.

2. Select **Software and Drivers**, select your type of product, enter the product name or number in the search box that is displayed, select your computer, and then select your operating system.
3. In the **Diagnostics** section, follow the on-screen instructions to select and download the **Remote UEFI** version for the product.

Customizing Remote HP PC Hardware Diagnostics UEFI settings

Using the Remote HP PC Hardware Diagnostics setting in Computer Setup (BIOS), you can perform several customizations.

- Set a schedule for running diagnostics unattended. You can also start diagnostics immediately in interactive mode by selecting **Execute Remote HP PC Hardware Diagnostics UEFI**.
- Set the location for downloading the diagnostic tools. This feature provides access to the tools from the HP website or from a server that has been preconfigured for use. Your computer does not require the traditional local storage (such as a hard drive or USB flash drive) to run remote diagnostics.
- Set a location for storing the test results. You can also set the user name and password that you use for uploads.
- Display status information about the diagnostics runs previously.

To customize Remote HP PC Hardware Diagnostics UEFI settings, follow these steps:

1. Turn on or restart the computer, and when the HP logo appears, press **F10** to enter Computer Setup.
2. Select **Advanced**, and then select **Settings**.
3. Make your customization selections.
4. Select **Exit**, then select **Save Changes and Exit** to save your settings.

Your changes take effect when the computer restarts.

9 Specifications

This chapter provides specifications for your computer system.

Computer specifications

This section provides specifications for your computer. When you travel with your computer, the computer dimensions and weights, as well as input power ratings and operating specifications, provide helpful information.

Table 9-1 Computer specifications

	Metric	U.S.
Dimensions		
Width	297.4 mm	11.71 in
Depth	220.4 mm	8.68 in
Height (front to back)	16.4 mm	0.65 in
Weight		
	0.9 kg	2.20 lb
Input power		
Operating voltage and current	19.5 V DC @ 2.31 A - 45 W	
	19.5 V DC @ 3.33 A - 65 W	
	19.5 V DC @ 4.62 A - 90 W	
	19.5 V DC @ 7.70 A - 150 W	
	19.5 V DC @ 10.3 A - 200 W	
Temperature		
Operating	5°C to 35°C	41°F to 95°F
Nonoperating	-20°C to 60°C	-4°F to 140°F
Relative humidity (noncondensing)		
Operating	10% to 90%	
Nonoperating	5% to 95%	
Maximum altitude (unpressurized)		
Operating	-15 m to 3,048 m	-50 ft to 10,000 ft
Nonoperating	-15 m to 12,192 m	-50 ft to 40,000 ft

Table 9-1 Computer specifications (continued)

	Metric	U.S.
NOTE: Applicable product safety standards specify thermal limits for plastic surfaces. The device operates well within this range of temperatures.		

Display specifications

This section provides specifications for your display.

Table 9-2 Display specifications

	Metric	U.S.
Active diagonal size	34.9 cm	13.5 in
Resolution	3000 × 2000 1920 × 1200	
Surface treatment	Brightview Antiglare	
Brightness	1000 nits 400 nits	
Viewing angle	UWVA	
Backlight	WLED + LBL	
Display panel interface	eDP 1.4 + PSR2 eDP 1.4 + PSR eDP 1.3 + PSR	

Solid-state drive specifications

This section provides specifications for your solid-state drives.

Table 9-3 Solid-state drive specifications

	256 GB*	512 GB*	1TB*
Dimensions			
Height	1.0 mm	1.0 mm	1.0 mm
Length	50.8 mm	50.8 mm	50.8 mm
Width	28.9 mm	28.9 mm	28.9 mm
Weight	< 10 g	< 10 g	< 10 g
Interface type			
Ready time, maximum (to not busy)	1.0 ms	< 1.0 ms	1.0 ms
Access times, logical	0.1 ms	0.1 ms	0.1 ms

Table 9-3 Solid-state drive specifications (continued)

	256 GB*	512 GB*	1 TB*
Transfer rate			
Sequential read	up to 2150 MBps	up to 2150 MBps	up to 2150 MBps
Random read	Up to 300,000 IOPs	Up to 300,000 IOPs	Up to 300,000 IOPs
Sequential write	up to 1550 MBps	up to 1550 MBps	up to 1550 MBps
Random write	Up to 100,000 IOPs	Up to 100,000 IOPs	Up to 100,000 IOPs
Total logical sectors	468,883,296	1,000,215,216	1,500,336,388
Operating temperature	0°C to 70°C (32°F to 158°F)		

*1 GB = 1 billion bytes when referring to hard drive storage capacity. Actual accessible capacity is less. Actual drive specifications may differ slightly.

NOTE: Certain restrictions and exclusions apply. Contact support for details.

10 Statement of memory volatility

For general information regarding nonvolatile memory in HP business computers, and to restore nonvolatile memory that can contain personal data after the system has been turned off and the hard drive has been removed, use these instructions.

HP business computer products that use Intel®-based or AMD®-based system boards contain volatile DDR memory. The amount of nonvolatile memory present in the system depends upon the system configuration. Intel-based and AMD-based system boards contain nonvolatile memory subcomponents as originally shipped from HP, with the following assumptions:

- No subsequent modifications were made to the system.
- No applications, features, or functionality were added to or installed on the system.

Following system shutdown and removal of all power sources from an HP business computer system, personal data can remain on volatile system memory (DIMMs) for a finite period of time and also remains in nonvolatile memory. Use the following steps to remove personal data from the computer, including the nonvolatile memory found in Intel-based and AMD-based system boards.



NOTE: If your tablet has a keyboard base, connect to the keyboard base before beginning steps in this chapter.

Current BIOS steps

Use these instructions to restore nonvolatile memory.

1. Follow these steps to restore the nonvolatile memory that can contain personal data. Restoring or reprogramming nonvolatile memory that does not store personal data is neither necessary nor recommended.
 - a. Turn on or restart the computer, and then quickly press **esc**.



NOTE: If the system has a BIOS administrator password, type the password at the prompt.

- b. Select **Main**, select **Apply Factory Defaults and Exit**, and then select **Yes** to load defaults. The computer restarts.
- c. During the restart, press **esc** while the "Press the ESC key for Startup Menu" message is displayed at the bottom of the screen.



NOTE: If the system has a BIOS administrator password, type the password at the prompt.

- d. Select the **Security** menu, select **Restore Security Settings to Factory Defaults**, and then select **Yes** to restore security level defaults. The computer restarts.
- e. During the restart, press **esc** while the "Press the ESC key for Startup Menu" message is displayed at the bottom of the screen.



NOTE: If the system has a BIOS administrator password, type the password at the prompt.

- f. If an asset or ownership tag is set, select the **Security** menu and scroll down to the **Utilities** menu. Select **System IDs**, and then select **Asset Tracking Number**. Clear the tag, and then make the selection to return to the prior menu.
- g. If a DriveLock password is set, select the **Security** menu, and scroll down to **Hard Drive Utilities** under the **Utilities** menu. Select **Hard Drive Utilities**, select **DriveLock**, and then clear the check box for **DriveLock password on restart**. Select **OK** to proceed.
- h. Select the **Main** menu, and then select **Reset BIOS Security to factory default**. Select **Yes** at the warning message. The computer restarts.
- i. During the restart, press **esc** while the "Press the ESC key for Startup Menu" message is displayed at the bottom of the screen.



NOTE: If the system has a BIOS administrator password, type the password at the prompt.

- j. Select the **Main** menu, select **Apply Factory Defaults and Exit**, select **Yes** to save changes and exit, and then select **Shutdown**.
 - k. Restart the system. If the system has a Trusted Platform Module (TPM), fingerprint reader, or both, one or two prompts will appear—one to clear the TPM and the other to Reset Fingerprint Sensor. Press or tap **f1** to accept or **f2** to reject.
 - l. Remove all power and system batteries for at least 24 hours.
2. Complete one of the following:
- Remove and retain the storage drive.
- or -
 - Clear the drive contents by using a third-party utility designed to erase data from an SSD.
- or -
 - Clear the contents of the drive by using the following BIOS Setup Secure Erase command option steps:



NOTE: If you clear data using Secure Erase, you cannot recover it.

- a. Turn on or restart the computer, and then quickly press **esc**.
- b. Select the **Security** menu and scroll down to the **esc** menu.
- c. Select **Hard Drive Utilities**.
- d. Under **Utilities**, select **Secure Erase**, select the hard drive storing the data you want to clear, and then follow the on-screen instructions to continue.
- or -

Clear the contents of the drive using the following Disk Sanitizer commands steps:

- i. Turn on or restart the computer, and then quickly press **esc**.
- ii. Select the **Security** menu and scroll down to the **Utilities** menu.
- iii. Select **Hard Drive Utilities**.
- iv. Under **Utilities**, select **Disk Sanitizer**, select the hard drive with the data that you want to clear, and then follow the on-screen instructions to continue.

 **NOTE:** The amount of time it takes for Disk Sanitizer to run can take several hours. Plug the computer into an AC outlet before starting.

Nonvolatile memory usage

Use this table to troubleshoot nonvolatile memory usage.

Table 10-1 Troubleshooting steps for nonvolatile memory usage

Description	Volatility description	Storage user data	How to erase
Primary storage device, holds the OS, applications, and application settings	Non-volatile, 8-256 GB of eMMC or NVMe SSD storage, removable	Yes ¹	Follow instructions below under “Erase the Primary Storage Device”
System memory (RAM), holds transient data during system operation	Volatile, SODIMM socket. Removable (4 GB/8 GB/16 GB)	Yes	Unplug unit from power
Permanent system BIOS settings	Non-volatile; 16 KB; stored	No ²	Follow instructions below under “Clearing BIOS Settings”
System boot ROM (BIOS)	Non-volatile memory, 128 Mbit (16 MB) socketed, removable	No	Download the latest BIOS for your model from the HP website and follow the instructions to flash the BIOS that are on the website
RTC (CMOS) RAM	Volatile memory, 256 bytes located in AMD embedded System on Chip (SoC)	No	Unplug unit from main power, remove top cover and press Clear CMOS button
Keyboard/mouse (ROM)	Non-volatile, 2 KB embedded in the super I/O controller (SIO2)	Yes	N/A
Keyboard/mouse (RAM)	Volatile, 256 bytes embedded in the super I/O controller (SIO2)	No	Unplug unit from main power
LOM EEPROM	Non-volatile, 2 MB embedded in LAN controller	No	N/A
Trusted Platform Module (TPM)	Non-volatile; 51 KB ROM for firmware and 38 KB system parametric data	No ³	Follow instructions below under “Clearing TPM”

¹ Under typical operation, the only user data stored on the primary storage device are preferences for device configuration and settings for connections. However, the administrator can configure the system to allow users to store data locally.

² Only user data potentially stored in BIOS Settings are the ownership and asset tags, administrator password, and startup password.

³ The Trusted Platform Module may contain encrypted passwords or certificates generated from user or administrator input.

Questions and answers

Use this section to answer your questions about nonvolatile memory.

1. How can the BIOS settings be restored (returned to factory settings)?

 **IMPORTANT:** The restore defaults feature does not securely erase any information on your hard drive. See question and answer 6 for steps to securely erase information.

The restore defaults feature does not reset the Custom Secure Boot keys. See question and answer 7 for information about resetting the keys.

- a. Turn on or restart the computer, and then quickly press `esc`.
- b. Select **Main**, and then select **Apply Factory Defaults and Exit**.
- c. Follow the on-screen instructions.
- d. Select **Main**, select **Save Changes and Exit**, and then follow the on-screen instructions.

2. What is a UEFI BIOS, and how is it different from a legacy BIOS?

The Unified Extensible Firmware Interface (UEFI) BIOS is an industry-standard software interface between the platform firmware and an operating system (OS). It replaces the older BIOS architecture but supports much of the legacy BIOS functionality.

Like the legacy BIOS, the UEFI BIOS provides an interface to display the system information and configuration settings and to change the configuration of your computer before an OS is loaded. BIOS provides a secure runtime environment that supports a Graphic User Interface (GUI). In this environment, you can use either a pointing device (touch screen, touchpad, pointing stick, or USB mouse) or the keyboard to navigate and make menu and configuration selections. The UEFI BIOS also contains basic system diagnostics.

The UEFI BIOS provides functionality beyond that of the legacy BIOS. In addition, the UEFI BIOS works to initialize the computer's hardware before loading and executing the OS; the runtime environment allows the loading and execution of software programs from storage devices to provide more functionality, such as advanced hardware diagnostics (with the ability to display more detailed system information) and advanced firmware management and recovery software.

HP has provided options in Computer Setup (BIOS) to allow you to run in legacy BIOS, if required by the operating system. Examples of this requirement would be if you upgrade or downgrade the OS.

3. Where is the UEFI BIOS located?

The UEFI BIOS is located on a flash memory chip. You must use a utility to write to the chip.

4. What kind of configuration data is stored on the DIMM Serial Presence Detect (SPD) memory module? How would this data be written?

The DIMM SPD memory contains information about the memory module, such as size, serial number, data width, speed and timing, voltage, and thermal information. This information is written by the module manufacturer and stored on an EEPROM. You cannot write to this EEPROM when the memory module is installed in a computer. Third-party tools do exist that can write to the EEPROM when the memory module is not installed in a computer. Various third-party tools are available to read SPD memory.

5. What is meant by "Restore the nonvolatile memory found in Intel-based system boards"?

This message relates to clearing the Real Time Clock (RTC) CMOS memory that contains computer configuration data.

6. How can the BIOS security be reset to factory defaults and erase the data?

 **IMPORTANT:** Resetting results in the loss of information.

These steps do not reset Custom Secure Boot Keys. See question and answer 7 for information about resetting the keys.

- a. Turn on or restart the computer, and then quickly press **esc**.
- b. Select **Main**, and then select **Reset Security to Factory Defaults**.
- c. Follow the on-screen instructions.
- d. Select **Main**, select **Save Changes and Exit**, and then follow the on-screen instructions.

7. How can the Custom Secure Boot Keys be reset?

Secure Boot is a feature to ensure that only authenticated code can start on a platform. If you enabled Secure Boot and created Custom Secure Boot Keys, disabling Secure Boot does not clear the keys. You must also select to clear the Custom Secure Boot Keys. Use the same Secure Boot access procedure that you used to create the Custom Secure Boot Keys, but select to clear or delete all Secure Boot Keys.

- a. Turn on or restart the computer, and then quickly press **esc**.
- b. Select the **Security** menu, select **Secure Boot Configuration**, and then follow the on-screen instructions.
- c. At the **Secure Boot Configuration** window, select **Secure Boot**, select **Clear Secure Boot Keys**, and then follow the on-screen instructions to continue.

Using HP Sure Start (select products only)

Select computer models are configured with HP Sure Start, a technology that continuously monitors your computer's BIOS for attacks or corruption.

If the BIOS becomes corrupted or is attacked, HP Sure Start restores the BIOS to its previously safe state, without user intervention. Those select computer models ship with HP Sure Start configured and enabled. HP Sure Start is configured and already enabled so that most users can use the HP Sure Start default configuration. Advanced users can customize the default configuration.

To access the latest documentation on HP Sure Start, go to <http://www.hp.com/support>.

11 Power cord set requirements

This chapter provides power cord requirements for countries and regions.

The wide-range input feature of the computer permits it to operate from any line voltage from 100 V AC to 120 V AC, or from 220 V AC to 240 V AC.

The three-conductor power cord set included with the computer meets the requirements for use in the country or region where the equipment is purchased.

Power cord sets for use in other countries or regions must meet the requirements of the country and region where the computer is used.

Requirements for all countries

These power cord requirements are applicable to all countries and regions.

- The length of the power cord set must be at least **1.0 m** (3.3 ft) and no more than **2.0 m** (6.5 ft).
- All power cord sets must be approved by an acceptable accredited agency responsible for evaluation in the country or region where the power cord set will be used.
- The power cord sets must have a minimum current capacity of 10 A and a nominal voltage rating of 125 V AC or 250 V AC, as required by the power system of each country or region.
- The appliance coupler must meet the mechanical configuration of an EN 60 320/IEC 320 Standard Sheet C13 connector for mating with the appliance inlet on the back of the computer.

Requirements for specific countries and regions

To determine power cord requirements for specific countries and regions, use this table.

Table 11-1 Power cord requirements for specific countries and regions

Country/region	Accredited agency	Applicable note number
Argentina	IRAM	1
Australia	SAA	1
Austria	OVE	1
Belgium	CEBEC	1
Brazil	ABNT	1
Canada	CSA	2

Table 11-1 Power cord requirements for specific countries and regions (continued)

Country/region	Accredited agency	Applicable note number
Chile	IMQ	1
Denmark	DEMKO	1
Finland	FIMKO	1
France	UTE	1
Germany	VDE	1
India	BIS	1
Israel	SII	1
Italy	IMQ	1
Japan	JIS	3
Netherlands	KEMA	1
New Zealand	SANZ	1
Norway	NEMKO	1
People's Republic of China	CCC	4
Saudi Arabia	SASO	7
Singapore	PSB	1
South Africa	SABS	1
South Korea	KTL	5
Sweden	SEMKO	1
Switzerland	SEV	1
Taiwan	BSMI	6
Thailand	TISI	1
United Kingdom	ASTA	1
United States	UL	2

Table 11-1 Power cord requirements for specific countries and regions (continued)

Country/region	Accredited agency	Applicable note number
		1. The flexible cord must be Type HO5VV-F, three-conductor, 0.75 mm ² conductor size. Power cord set fittings (appliance coupler and wall plug) must bear the certification mark of the agency responsible for evaluation in the country or region where it will be used.
		2. The flexible cord must be Type SVT/SJT or equivalent, No. 18 AWG, three-conductor. The wall plug must be a two-pole grounding type with a NEMA 5-15P (15 A, 125 V AC) or NEMA 6-15P (15 A, 250 V AC) configuration. CSA or C-UL mark. UL file number must be on each element.
		3. The appliance coupler, flexible cord, and wall plug must bear a T mark and registration number in accordance with the Japanese Dentori Law. The flexible cord must be Type VCTF, three-conductor, 0.75 mm ² or 1.25 mm ² conductor size. The wall plug must be a two-pole grounding type with a Japanese Industrial Standard C8303 (7 A, 125 V AC) configuration.
		4. The flexible cord must be Type RVV, three-conductor, 0.75 mm ² conductor size. Power cord set fittings (appliance coupler and wall plug) must bear the CCC certification mark.
		5. The flexible cord must be Type H05VV-F three-conductor, 0.75 mm ² conductor size. KTL logo and individual approval number must be on each element. Approval number and logo must be printed on a flag label.
		6. The flexible cord must be Type HVCTF three-conductor, 1.25 mm ² conductor size. Power cord set fittings (appliance coupler, cable, and wall plug) must bear the BSMI certification mark.
		7. For 127 V AC, the flexible cord must be Type SVT or SJT 3-conductor, 18 AWG, with plug NEMA 5-15P (15 A, 125 V AC), with UL and CSA or C-UL marks. For 240 V AC, the flexible cord must be Type H05VV-F three-conductor, 0.75 mm ² or 1.00 mm ² conductor size, with plug BS 1363/A with BSI or ASTA marks.

12 Recycling

When a nonrechargeable or rechargeable battery has reached the end of its useful life, do not dispose of the battery in general household waste. Follow the local laws and regulations in your area for battery disposal.

HP encourages customers to recycle used electronic hardware, HP original print cartridges, and rechargeable batteries. For more information about recycling programs, see the HP website at <http://www.hp.com/recycle>.

Index

A

- AC adapter
 - spare part numbers 35
- adapter
 - spare part numbers 35
- ambient light sensor, identifying
 - color sensor, identifying 9
- audio-out (headphone)/audio-in (microphone) combo jack, identifying 7
- audio, product description 2
- Auto Lock and Awake 8, 10

B

- backup, creating 80
- backups 80
- bag, spare part numbers 35
- battery
 - illustrated 33
 - removal 50
 - spare part numbers 33, 50
- battery light 6, 8
- BIOS
 - determining version 77
 - downloading an update 77, 78
 - updating 77
- boot order
 - changing using the f9 prompt 78
- boot order, changing 82
- bottom cover
 - illustrated 33
 - removal 48
 - spare part numbers 33, 48
- Bracket Kit, spare part number 35
- buttons
 - left touchpad 11
 - power 14, 15
 - right touchpad 11

C

- cable, spare part numbers 35
- cables
 - spare part numbers 34
- camera 10
 - identifying 10
- camera light, identifying 9
- camera privacy key, identifying 15
- camera privacy light, identifying 12
- caps lock light, identifying 12
- card reader cable
 - illustrated 34
 - spare part number 34
- caring for your computer 43
- cautions
 - electrostatic discharge 39, 40
- chipset, product description 1
- cleaning your computer 43
 - caring for wood veneer 45
 - disinfecting 44
 - HP Easy Clean 43
 - removing dirt and debris 43
- components
 - bottom 15
 - display 8, 9
 - keyboard area 10
 - left side 7
 - right side 5
- Computer Setup
 - navigating and selecting 76
 - restoring factory settings 77
 - starting 76
- computer specifications 89
- connector board
 - illustrated 31
 - removal 54
 - spare part numbers 31, 54
- connector board cable
 - illustrated 34
 - spare part number 34

- connector, power 6, 8

D

- display
 - specifications 89, 90
- display assembly
 - illustrated 21
 - removal 55
 - spare part numbers 21, 55
- display components 8, 9
- display panel
 - product description 1
- dock, spare part numbers 35
- duck head adapter, spare part numbers 36

E

- electrostatic discharge (ESD) 39, 40
 - preventing damage 39-41
- eMMC
 - product description 1
- esc key, identifying 14

F

- fan/heat sink assembly
 - removal 58
 - spare part numbers 58
- fingerprint reader
 - illustrated 31
 - removal 65
 - spare part numbers 31, 65
- fingerprint reader cable
 - illustrated 31, 34
 - removal 64
 - spare part number 31, 34, 64
- fingerprint reader, identifying 13
- fn key, identifying 15
- fn lock light, identifying 12
- front speakers
 - illustrated 33
 - removal 73

spare part number 33, 73

G

grounding methods 39-41

guidelines

- packaging 39, 45
- transporting 39, 45
- workstation 39

H

hard drive

- specifications 89

hardware, locating 5

HDMI port, identifying 7

heat sink

- illustrated 31
- spare part numbers 31

HP PC Hardware Diagnostics UEFI

- downloading 86
- failure ID code 85
- HP Hotkey Support software 86
- starting 85, 86
- using 85

HP PC Hardware Diagnostics

- Windows
- accessing 83, 84
- downloading 84
- failure ID code 83
- installing 85
- using 83

HP Recovery media

- recovery 81

HP Sure Recover 82

HP Sure Start 92, 96

hub, spare part numbers 36

I

illustrated parts catalog 20

internal microphones,

- identifying 9

interposer board

- illustrated 33
- removal 55
- spare part number 33, 55

J

jacks

- audio-out (headphone)/audio-in (microphone) combo 7

K

keyboard

- product description 3

keyboard, spare part number 36

keys

- camera privacy 15
- esc 14
- fn 15
- Windows 15

L

labels

- contents 17
- locations 17

left side components 7

lights

- AC adapter and battery 6, 8
- battery 6, 8
- camera 9
- camera privacy 12
- caps lock 12
- fn lock 12
- microphone mute 12
- power 12
- privacy key 12

lights, mute 12

lock, spare part numbers 36

low blue light mode 9

M

memory

- nonvolatile 92
- volatile 92

memory module

- product description 1

microphone

- product description 2

microphone mute light,

- identifying 12

model name 1

mouse, spare part numbers 36

mute light, identifying 12

N

nano SIM card, inserting 16

Near Field Communications (NFC)

- tapping area and antenna, identifying 11

NFC module

- illustrated 31
- removal 71
- spare part number 31, 71

NFC module antenna

- illustrated 31
- spare part number 31

NFC module cable

- illustrated 34
- removal 70
- spare part number 34, 70

nonvolatile memory 92

O

operating system, product

- description 4

optical drive, spare part

- number 36

P

packaging guidelines 39, 45

Plastics Kit, spare part

- number 36

pointing device, product

- description 3

ports

- HDMI 7
- product description 2
- USB port with HP Sleep and Charge 6
- USB Type-C power connector and Thunderbolt port with HP Sleep and Charge 6, 8

power button, identifying 14, 15

power connector

- identifying USB Type-C 6, 8

power cord

- requirements for all countries 97
- requirements for specific countries and regions 97
- set requirements 97
- spare part numbers 36-38

power lights 12

power requirements, product

- description 3

privacy key light 12

processor

- product description 1

product description

- audio 2
- chipset 1
- display panel 1
- eMMC 1
- keyboard 3
- memory module 1
- microphone 2
- operating system 4

- pointing device 3
- ports 2
- power requirements 3
- processors 1
- product name 1
- security 3
- sensors 3
- serviceability 4
- storage 2
- video 2
- wireless 2
- product name 1

R

- rear speakers
 - illustrated 31
 - removal 60
 - spare part number 31, 60
- recovery 80, 81
 - discs 81
 - media 81
 - USB flash drive 81
- recovery media 80
 - creating using HP Cloud Recovery Download Tool 80
 - creating using Windows tools 80
- Remote HP PC Hardware Diagnostics UEFI settings
 - customizing 88
 - using 87
- removal and replacement procedures 48
- removing personal data from volatile system memory 92
- restoring 80
- restoring and recovery methods 81
- right side components 5

S

- Screw Kit, spare part number 38
- security cable slot, identifying 6
- security, product description 3
- sensors, product description 3
- serviceability, product description 4
- setup utility
 - navigating and selecting 76
 - restoring factory settings 77
- SIM card slot, identifying 7
- SIM card, correct size 16
- SIM card, inserting 16

- slots
 - security cable 6
 - SIM card 7
- software installed, locating 5
- solid-state drive
 - illustrated 33
 - removal 51
 - spare part numbers 33, 34, 51
 - specifications 90
- solid-state drive shield
 - illustrated 33
 - removal 52
 - spare part number 33, 52
- spare part country codes 74
- speakers
 - illustrated 31, 33
 - removal 60, 73
 - spare part numbers 31, 33, 60, 73
- speakers, identifying 13, 16
- special keys, using 14
- specifications
 - computer 89
 - display 89, 90
 - hard drive 89
 - solid-state drive 90
- static electricity 39, 40
- storage
 - product description 2
- support information 46
- Sure Start
 - using 79
- system board
 - illustrated 32
 - removal 61
 - spare part numbers 32, 61
- System Board Repair Support Kit,
 - spare part number 33
- system memory, removing personal data from volatile 92
- system restore 81
- system restore point, creating 80

T

- Thermal Material Kit
 - spare part number 31
- top cover with keyboard
 - illustrated 22-27, 29, 30
 - spare part numbers 22-27, 29, 30, 74
- touchpad
 - illustrated 31
 - removal 67
 - settings 10

- spare part numbers 31, 67
- touchpad buttons
 - identifying 11
- touchpad cable
 - illustrated 31, 34
 - removal 66
 - spare part number 31, 34, 66
- touchpad settings, adjusting 10
- touchpad zone, identifying 11
- TPM settings 79
- transfer board
 - removal 69
 - spare part number 31, 69
- transfer board cable
 - illustrated 31
 - removal 68
 - spare part number 31, 68
- transporting guidelines 39, 45

U

- USB port with HP Sleep and Charge, identifying 6
- USB Type-C power connector and Thunderbolt port with HP Sleep and Charge, identifying 6, 8
- user-proximity sensor, identifying 10

V

- vents, identifying 16
- video, product description 2

W

- Windows
 - backup 80
 - recovery media 80
 - system restore point 80
- Windows key, identifying 15
- Windows tools, using 80
- wireless antennas, identifying 9, 10
- wireless, product description 2
- WLAN antennas, identifying 9
- workstation guidelines 39
- WWAN antenna
 - illustrated 33
 - removal 72
 - spare part number 33, 72
- WWAN antennas, identifying 10
- WWAN module
 - illustrated 33
 - removal 53
 - spare part numbers 33, 53