



Hardware Installation Guide for Cisco Catalyst 8200 Series Edge Platforms

First Published: 2020-11-15

Last Modified: 2021-02-17

Americas Headquarters

Cisco Systems, Inc.
170 West Tasman Drive
San Jose, CA 95134-1706
USA
<http://www.cisco.com>
Tel: 408 526-4000
800 553-NETS (6387)
Fax: 408 527-0883

THE SPECIFICATIONS AND INFORMATION REGARDING THE PRODUCTS IN THIS MANUAL ARE SUBJECT TO CHANGE WITHOUT NOTICE. ALL STATEMENTS, INFORMATION, AND RECOMMENDATIONS IN THIS MANUAL ARE BELIEVED TO BE ACCURATE BUT ARE PRESENTED WITHOUT WARRANTY OF ANY KIND, EXPRESS OR IMPLIED. USERS MUST TAKE FULL RESPONSIBILITY FOR THEIR APPLICATION OF ANY PRODUCTS.

THE SOFTWARE LICENSE AND LIMITED WARRANTY FOR THE ACCOMPANYING PRODUCT ARE SET FORTH IN THE INFORMATION PACKET THAT SHIPPED WITH THE PRODUCT AND ARE INCORPORATED HEREIN BY THIS REFERENCE. IF YOU ARE UNABLE TO LOCATE THE SOFTWARE LICENSE OR LIMITED WARRANTY, CONTACT YOUR CISCO REPRESENTATIVE FOR A COPY.

The following information is for FCC compliance of Class A devices: This equipment has been tested and found to comply with the limits for a Class A digital device, pursuant to part 15 of the FCC rules. These limits are designed to provide reasonable protection against harmful interference when the equipment is operated in a commercial environment. This equipment generates, uses, and can radiate radio-frequency energy and, if not installed and used in accordance with the instruction manual, may cause harmful interference to radio communications. Operation of this equipment in a residential area is likely to cause harmful interference, in which case users will be required to correct the interference at their own expense.

The following information is for FCC compliance of Class B devices: This equipment has been tested and found to comply with the limits for a Class B digital device, pursuant to part 15 of the FCC rules. These limits are designed to provide reasonable protection against harmful interference in a residential installation. This equipment generates, uses and can radiate radio frequency energy and, if not installed and used in accordance with the instructions, may cause harmful interference to radio communications. However, there is no guarantee that interference will not occur in a particular installation. If the equipment causes interference to radio or television reception, which can be determined by turning the equipment off and on, users are encouraged to try to correct the interference by using one or more of the following measures:

- Reorient or relocate the receiving antenna.
- Increase the separation between the equipment and receiver.
- Connect the equipment into an outlet on a circuit different from that to which the receiver is connected.
- Consult the dealer or an experienced radio/TV technician for help.

Modifications to this product not authorized by Cisco could void the FCC approval and negate your authority to operate the product.

The Cisco implementation of TCP header compression is an adaptation of a program developed by the University of California, Berkeley (UCB) as part of UCB's public domain version of the UNIX operating system. All rights reserved. Copyright © 1981, Regents of the University of California.

NOTWITHSTANDING ANY OTHER WARRANTY HEREIN, ALL DOCUMENT FILES AND SOFTWARE OF THESE SUPPLIERS ARE PROVIDED "AS IS" WITH ALL FAULTS. CISCO AND THE ABOVE-NAMED SUPPLIERS DISCLAIM ALL WARRANTIES, EXPRESSED OR IMPLIED, INCLUDING, WITHOUT LIMITATION, THOSE OF MERCHANTABILITY, FITNESS FOR A PARTICULAR PURPOSE AND NON-INFRINGEMENT OR ARISING FROM A COURSE OF DEALING, USAGE, OR TRADE PRACTICE.

IN NO EVENT SHALL CISCO OR ITS SUPPLIERS BE LIABLE FOR ANY INDIRECT, SPECIAL, CONSEQUENTIAL, OR INCIDENTAL DAMAGES, INCLUDING, WITHOUT LIMITATION, LOST PROFITS OR LOSS OR DAMAGE TO DATA ARISING OUT OF THE USE OR INABILITY TO USE THIS MANUAL, EVEN IF CISCO OR ITS SUPPLIERS HAVE BEEN ADVISED OF THE POSSIBILITY OF SUCH DAMAGES.

Any Internet Protocol (IP) addresses and phone numbers used in this document are not intended to be actual addresses and phone numbers. Any examples, command display output, network topology diagrams, and other figures included in the document are shown for illustrative purposes only. Any use of actual IP addresses or phone numbers in illustrative content is unintentional and coincidental.

All printed copies and duplicate soft copies of this document are considered uncontrolled. See the current online version for the latest version.

Cisco has more than 200 offices worldwide. Addresses and phone numbers are listed on the Cisco website at www.cisco.com/go/offices.

Cisco and the Cisco logo are trademarks or registered trademarks of Cisco and/or its affiliates in the U.S. and other countries. To view a list of Cisco trademarks, go to this URL: <https://www.cisco.com/c/en/us/about/legal/trademarks.html>. Third-party trademarks mentioned are the property of their respective owners. The use of the word partner does not imply a partnership relationship between Cisco and any other company. (1721R)

© 2020 Cisco Systems, Inc. All rights reserved.



CONTENTS

CHAPTER 1

Overview 1

- Chassis Views 2
 - Power-input and I/O sides 2
 - Platform Summary 3
- Location of labels 4
- Locate Product Identification Details 4
- Hardware Features of Cisco Catalyst 8200 Series Edge Platforms 5
 - Built-In Interface Ports 5
 - GE or SFP Ports 5
 - Removable and Interchangeable Modules and Cards 6
 - Memory 6
 - Power Supply 7
 - LEDs for Cisco Catalyst 8200 Series Edge Platforms 7
 - Fans, Ventilation, and Airflow 9
 - Chassis Ventilation 9
 - Slots, Subslots-Bay, Ports, and Interfaces 9
 - Slot Numbering 10

CHAPTER 2

Prepare for Installation 11

- Standard Warning Statements 11
 - General Safety Warnings 11
- Safety Recommendations 15
 - Safety with Electricity 15
 - Prevent Electrostatic Discharge Damage 17
- General Site Requirements 17
 - General Precautions 17

Site Selection Guidelines	18
Site Environmental Requirements	18
Physical Characteristics	18
Rack Requirements	19
Power Guidelines and Requirements	19
Network Cabling Specifications	19
Console Port Considerations	19
EIA/TIA-232	20
Prepare for Network Connections	20
Ethernet Connections	20
Required Tools and Equipment for Installation and Maintenance	20

CHAPTER 3

Install and Connect	23
Safety Warnings	23
What You Need to Know	24
Before You Begin	25
Unpack the Device	25
Install the Device	25
Mount the Chassis on a Desktop	26
Rack Mount the Chassis	27
Attach the Rack-Mounting Brackets	27
Mount the Chassis on a Rack	28
Attach Cisco Catalyst 8200 Series Edge Platforms on a Wall	31
Ground the Chassis	34
Chassis Grounding	34
Connect Power to the Device	36
Overview of the Power Options	37
Powering On the Server	37
Connect to a Console Terminal or Modem	38
Connect to the Console Port with Mac OS X	39
Connect to the Console Port with Linux	39
Connect WAN Interfaces	40
Ports and Cabling	40
General Precautions	41

CHAPTER 4	Install Internal Components and Field Replaceable Units	43
	Safety Warnings	43
	Locate and Access Internal Components	44
	Remove and Replace the Chassis Cover	45
	Remove the Cover	45
	Replace the Cover	46
	Remove and Replace DDR DIMMs	46
	Locate and Orient DIMM	47
	Remove a DIMM	47
	Install a DIMM	48
	Install and Remove SFP Modules	49
	Laser Safety Guidelines	50
	Remove Small Form Pluggable Modules	51
	Remove and Replace the USB Flash Token Memory Stick	52
	Remove and Install an M.2 USB NVMe Module	52
	Prevent Electrostatic Discharge Damage	53
	Remove the M.2 USB NVMe Module	53
	Install the M.2 USB NVMe Module	54

CHAPTER 5	Install Cisco Catalyst Network Interface Module	57
	Overview of the Network Interface Module	57
	Remove and Install Network Interface Modules	58
	Remove the Network Interface Module	58
	Install the Cisco Catalyst Network Interface Modules	58

CHAPTER 6	Cisco Catalyst Pluggable Interface Module	59
	Safety Recommendations	60
	Tools and Equipment Required During Installation	60
	Remove Cisco Catalyst Pluggable Interface Module	60
	Install a Cisco Catalyst Pluggable Interface Module	61
	Configuring a Pluggable Interface Module	62
	RF Band Mapping for Antenna Ports (For P-5GS6-GL only)	63
	Attaching the Antennas	64

CHAPTER 7 **Online Insertion and Removal and Hot-Swapping** **67**

 OIR Procedures **67**

 Remove a Module **68**

 Insert a Module **68**



CHAPTER 1

Overview

The Cisco Catalyst 8200 Series Edge Platforms are best-of-breed, 5G-ready, cloud edge platforms designed for accelerated services, multi-layer security, cloud-native agility, and edge intelligence to accelerate your journey to cloud.

Cisco Catalyst 8200 Series Edge Platforms with Cisco IOS XE SD-WAN Software deliver Cisco's secure, cloud-scale SD-WAN solution for the branch. The Cisco Catalyst 8200 Series Edge Platforms is built for high performance and integrated SD-WAN Services along with flexibility to deliver security and networking services together from the cloud or on premises. It provides higher WAN port density and a redundant power supply capability. The Cisco Catalyst 8200 Series Edge Platforms have a wide variety of interface options to choose from—ranging from lower and higher module density with backward compatibility to a variety of existing WAN, LTE, voice, and compute modules. Powered by Cisco IOS XE, fully programmable software architecture, and API support, these platforms can facilitate automation at scale to achieve zero-touch IT capability while migrating workloads to the cloud. The Cisco Catalyst 8200 Series Edge Platforms also come with Trustworthy Solutions 2.0 infrastructure that secures the platforms against threats and vulnerabilities with integrity verification and remediation of threats.

The Cisco Catalyst 8200 Series Edge Platforms are well suited for medium-sized and large enterprise branch offices for high WAN IPsec performance with integrated SD-WAN services.

Cisco Catalyst 8200 Series Edge Platforms target these use cases:

- Enterprise Branch office, Managed Service Provide CPE, Internet Gateway for DIA, SASE cloud platform with SD-WAN
- Next-generation of Software Defined (SD) Branch routing platforms

For more information on the features and specifications, refer to the Cisco Catalyst 8200 Series Edge Platforms datasheet.



Note Sections in this documentation apply to all models of Cisco Catalyst 8200 Series Edge Platforms unless a reference to a specific model is made explicitly.

This chapter contains the following sections:

- [Chassis Views, on page 2](#)
- [Location of labels, on page 4](#)
- [Locate Product Identification Details, on page 4](#)
- [Hardware Features of Cisco Catalyst 8200 Series Edge Platforms, on page 5](#)

Chassis Views

This section contains views of the Power-input and I/O sides of the Cisco Catalyst 8200 Series Edge Platforms, showing the locations of power and signal interfaces, module slots, status indicators, and chassis identification labels:

Cisco Catalyst 8200 Series Edge Platforms are available in these models:

- C8200-1N-4T
- C8200L-1N-4T



Note N=Network Interface Modue, and T=Gigabit Ethernet

Power-input and I/O sides

Figure 1: Cisco 8200 Series Chassis - I/O Side

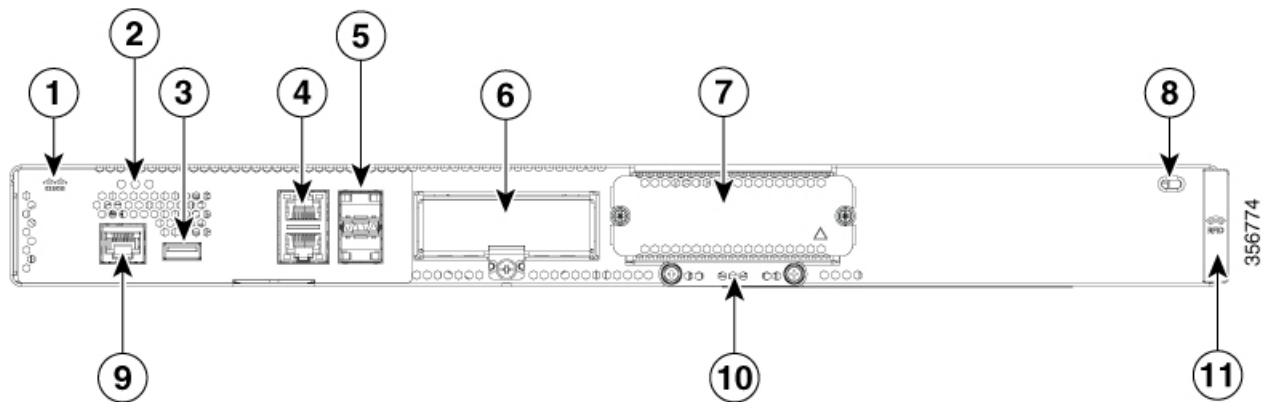

Table 1: I/O Side

1	Logo	2	Status LEDs
3	USB	4	RJ-45 ports GE0/0/0-0/0/1
5	Gigabit Ethernet ports GE0/0/2 - 0/0/3 (SFP)	6	LTE module (PIM)
7	NIM Module	8	Kensington lock
9	RJ-45 Console	10	M.2 USB/NVMe storage
11	RFID (Provisionable)		

Figure 2: Cisco 8200 Series Chassis - Power-input Side

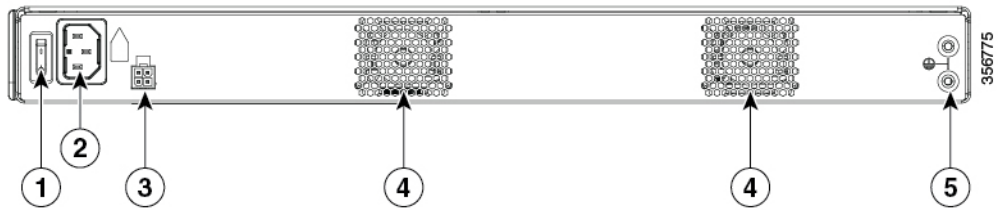

Table 2: Power-input Side

1	Switch	2	AC power socket
3	PoE Adapter	4	Fan
5	Ground lug securing location		

For detailed information on LEDs, see the section on LED indicators.

Platform Summary

The figure below shows the internal view of Cisco Catalyst 8200 Series Edge Platforms with components and module locations.

Figure 3: Platform Summary of Cisco 8200 Series Edge Platforms

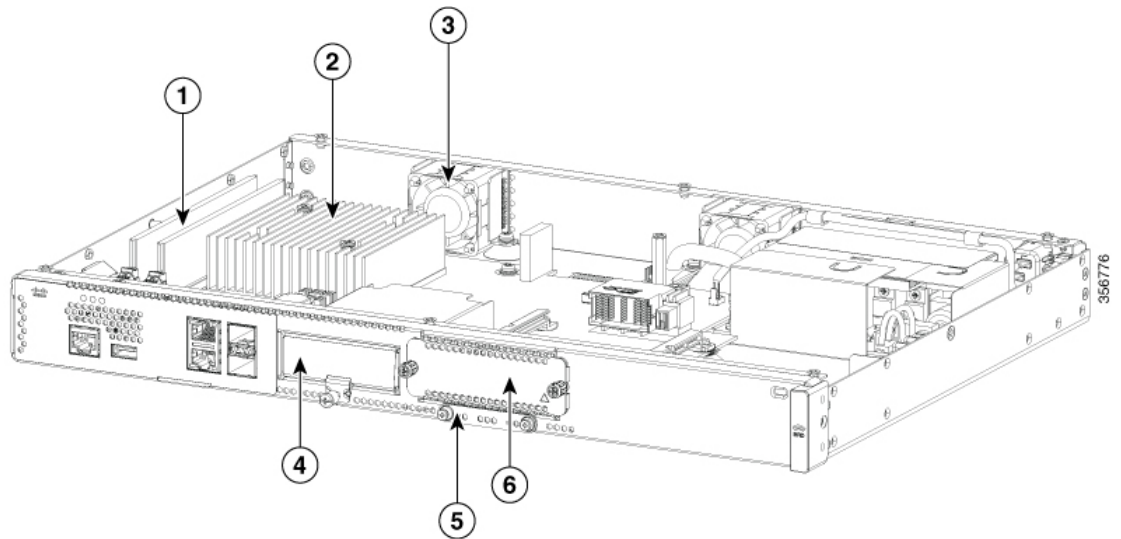

1	DIMMs	2	CPU
3	Fan	4	PIM slot

5	M.2 card slot	6	NIM slot
---	---------------	---	----------

Location of labels

The figure below shows the location of the labels on the Cisco Catalyst 8200 Series Edge Platforms. Labels are located at the same location on all the Cisco Catalyst 8200 Series Edge Platforms.

The Serial number (SN), Common language equipment identifier (CLEI), Top Assembly Number (TAN), Product ID (PID), PID version ID (VID), and Quick response (QR) code are printed on a label on the back of the platform or on a label tray located on the chassis.



Note The RFID tags on the devices are pre-fitted and does not come with spare RFID tags.

Figure 4: Label Location on a Cisco 8200 Series Edge Platforms

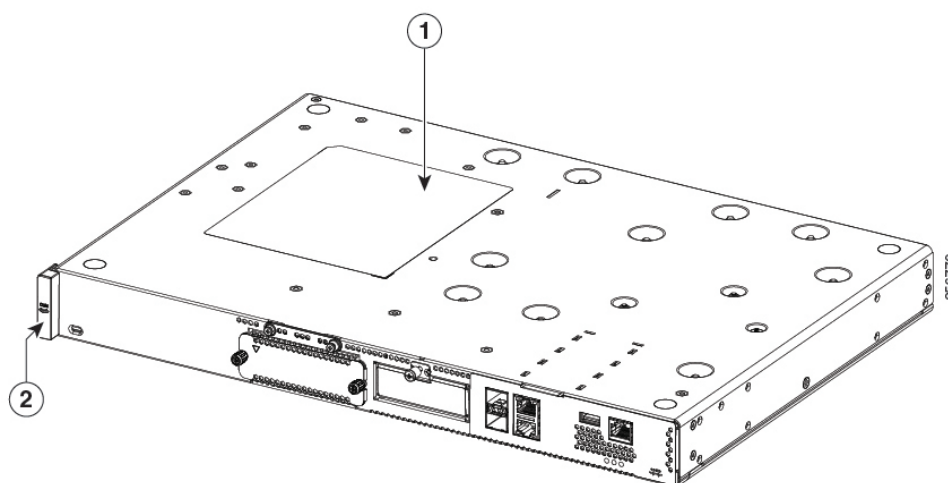

1	Compliance label	2	RFID
---	------------------	---	------

Locate Product Identification Details

Software License

The serial number (SN), product ID (PID), version ID (VID), and Common Language Equipment Identifier (CLEI) are printed on a label on the bottom of the device or on the label tray.

To obtain a software license, you need the unique device identifier (UDI) of the device where the license is to be installed.

The UDI has two main components:

- Product ID (PID)

- Serial number (SN)

The UDI can be viewed using the **show license udi** command in privileged Exec mode in Cisco Internet Operating System (IOS) software.

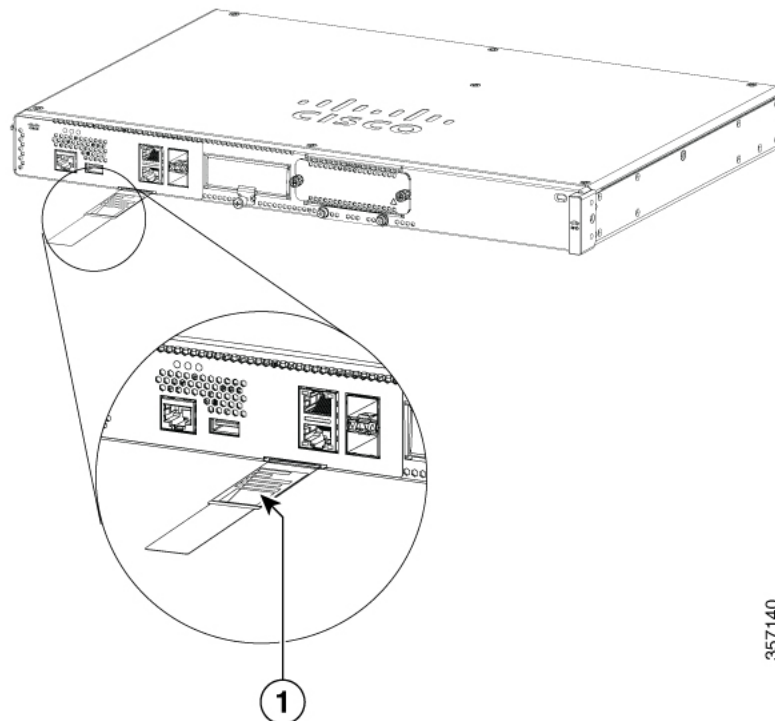

357140

1	Label tray
---	------------

Hardware Features of Cisco Catalyst 8200 Series Edge Platforms

This section describes the hardware features of Cisco Catalyst 8200 Series Edge Platforms.

Built-In Interface Ports

The Cisco Catalyst 8200 Series Edge Platforms have multiple 10/100/1000 front panel ports and Small Form Pluggables.

GE or SFP Ports

The following GE and SFP ports are available on the Cisco Catalyst 8200 Series Edge Platforms:

GE Ports

The GE RJ-45 copper interface ports support 10BASE-T, 100BASE-TX, and 1000BASE-T.

SFP Ports

The small-form-factor pluggable (SFP) ports support 1Gbps SFP modules.

Removable and Interchangeable Modules and Cards

Network Interface Modules (NIMs), Pluggable Interface Modules (PIMs) and M.2 USB/NVMe storage fit into external slots and can be removed or replaced without opening the chassis.

External Slots

- Network Interface Modules (NIMs)
- Pluggable Interface Modules (PIMs)
- M.2 USB/NVMe storage



Note The LTE Pluggable Interface Module interfaces with the host CPU through the USB3.0 interface. The host then accesses the LTE related signals through the I2C interface of the pluggable module.

Internal Slots

- Memory

See the Cisco Catalyst 8200 Series Edge Platforms product page on cisco.com for a list of supported modules and interface cards.

Memory

Cisco Catalyst 8200 Series Edge Platforms contain DIMMs that store running configuration and routing tables, and are used for packet buffering by the network interfaces.

- Boot/NVRAM—Stores the bootstrap program (ROM monitor) and the configuration register. The boot/NVRAM is not serviceable.
- Internal memory—Internal bootflash memory
- Removable M.2 card—Available in 16GB (default), 32GB M.2 USB, 600GB M.2 NVMe SSD and 2TB M.2 NVMe.
- DRAM options
 - 1x 8GB DDR4 (default)
 - 1x 16GB DDR4 (upgrade)
 - 1x 32GB DDR4 (upgrade)



Note The default DRAM for C8200L-1N-4T is 4GB.

Power Supply

The Cisco Catalyst 8200 Series Edge Platforms have an internal Power supply. The appropriate AC-cord is provided with the product to connect to the AC power socket. Optional PoE is available with a PoE adapter. Refer the Figure 2 for the power connection locations (AC power socket and PoE adapter).

LEDs for Cisco Catalyst 8200 Series Edge Platforms

Figure 5: Front (I/O) Side LED Status Indicators

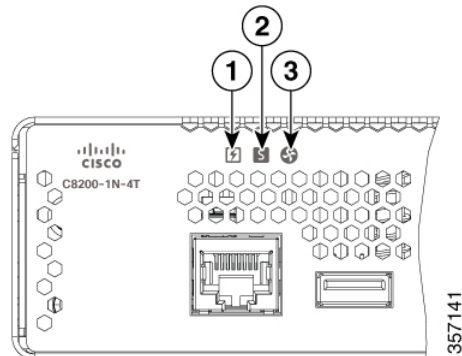

Table 3: LEDs Indicators

LED	Color	Description
1 PSU	Green/Amber	Power Supply Status Off: The system is powered off Green: All installed PSUs are operating correctly
2 STATUS	Green/Amber/Red	System Status Red: The system is booting Red Blinking Red: The system has failed a hardware integrity error Yellow: Rommon has completed booting and system at Rommon prompt or booting platform software. Green: Normal System Operation

LED	Color	Description
3 ENV	Green/Amber/Red	<p>Environmental Status</p> <p>Off: Monitor is not active.</p> <p>Red: The system has detected a critical overcurrent event and may shut down.</p> <p>Blinking Yellow: One or more temperature sensors in the system are outside the acceptable range.</p> <p>Yellow: One or more fans in the system are outside the acceptable range.</p> <p>Green: All temperature sensors and fans in the system are within acceptable range.</p>
LINK	Green	<p>RJ-45 Management Ethernet Link LED</p> <p>Off: No link</p> <p>Green: Ethernet cable present and link established with other side</p>
SPEED	Green	<p>RJ-45 Management Ethernet Speed LED</p> <p>Off: No Link</p> <p>Blinking Green: blink frequency indicates port speed:</p> <p>1 blink – 10Mbps link speed</p> <p>2 blinks – 100Mbps link speed</p> <p>3 blinks – 1000Mbps link speed</p>
SFP EN	Green	<p>SFP Enable LED</p> <p>Off: Not present</p> <p>Green: The SFP is supported and no faults.</p> <p>Amber: The SFP is not supported or is in a faulty state</p>
SFP LINK	Green	<p>SFPs Link LED</p> <p>Off: No Link (or not present)</p> <p>Green: Link established</p>

Fans, Ventilation, and Airflow

Chassis Ventilation

The chassis temperature is regulated with internal fans. An onboard temperature sensor and pressure sensor control the fans speed. The fans are always on when the device is powered on. Under all conditions, the fans operate at the slowest speed possible to conserve power and reduce noise. When necessary, the fans operate at higher speeds under conditions of higher ambient temperature and altitude.

Figure 6: Airflow of C8200 Series Edge Platforms

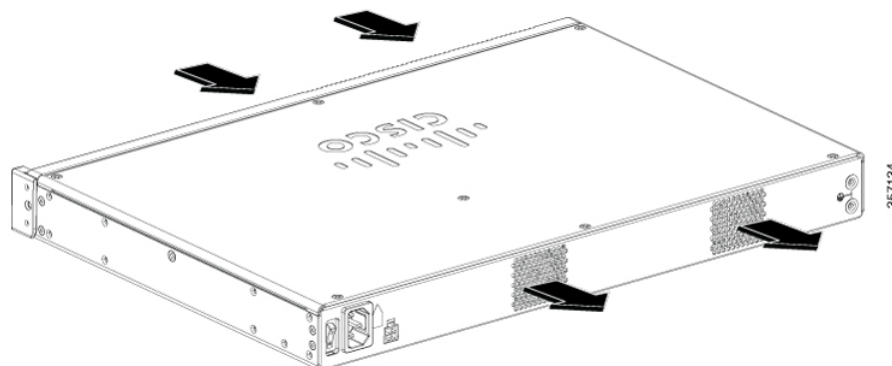

Slots, Subslots-Bay, Ports, and Interfaces

The Cisco Catalyst 8200 Series Edge Platforms support interface modules: Network Modules (NIMs) and Pluggable Interface Modules (PIMs).

In all cases, the device designates its interfaces using a 3-tuple notation that lists the slot, bay, and port. The 3-tuple value is zero based. An example of a 3-tuple is 0/1/2. This refers to slot 0, the second bay in slot 0 (the first bay is 0 so the second bay is 1), and the third port in bay 1. See the following table for more examples.

Table 4: Slot, Subslot-Bay and Port Numbering

3-Tuple Example	Slot	Bay	Port
0/1/2	0	2nd	3rd
0/0/1	0	1st	2nd
1/1/1	1	2nd	2nd

- Slots and bays are numbered from the left to the right, and from the top to the bottom.
- There is one USB port-USB0. They do not have slot or bay numbers.



Note USB0 can be used to insert flash drives.

Slot Numbering

Slots are numbered 0, 1, and 2.

About Slot 0

The following are the main features of Slot 0:

- Slot 0 is reserved for integrated ports and NIMs.

Subslot and Bay Numbering

- Integrated devices, also known as integrated ports or FPGEs, and NIMs reside in a fixed section of bay 0.
- Motherboard NIMs bays start at bay 1 because the integrated devices and integrated NIMs take up bay 0.



CHAPTER 2

Prepare for Installation

This chapter provides preinstallation information, such as recommendations and requirements that must be met before installing your platform. Before you begin, inspect all items for shipping damage. If anything appears to be damaged or if you encounter problems installing or configuring your platform, contact customer service.

- [Standard Warning Statements, on page 11](#)
- [Safety Recommendations, on page 15](#)
- [General Site Requirements, on page 17](#)
- [Rack Requirements, on page 19](#)
- [Power Guidelines and Requirements, on page 19](#)
- [Network Cabling Specifications, on page 19](#)
- [Required Tools and Equipment for Installation and Maintenance, on page 20](#)

Standard Warning Statements

This section describes the warning definition and then lists core safety warnings grouped by topic.



Warning

Before you work on any equipment, be aware of the hazards involved with electrical circuitry and be familiar with standard practices for preventing accidents. Read the installation instructions before using, installing or connecting the system to the power source. Use the statement number provided at the end of each warning statement to locate its translation in the translated safety warnings for this device.

Note: SAVE THESE INSTRUCTIONS Statement 1071

General Safety Warnings



Warning

Read the installation instructions before you connect the system to its power source. Statement 1004



Warning

Ultimate disposal of this product should be handled according to all national laws and regulations. Statement 1040



Warning Installation of the equipment must comply with local and national electrical codes. Statement 1074



Warning Power cable and AC adapter - When installing the product, please use the provided or designated connection cables/power cables/AC adaptors. Using any other cables or adapters could cause a malfunction or a fire. Electrical Appliance and Material Safety Law prohibits the use of certified cables (that have the 'UL' shown on the code) for any other electrical devices than products designated by Cisco. The use of cables that are certified by Electrical Appliance and Material Safety Law (that have 'PSE' shown on the code) is not limited to Cisco-designated products. Statement 371



Warning Only trained and qualified personnel should be allowed to install or replace this equipment. Statement 1030



Warning This product relies on the building's installation for short-circuit (overcurrent) protection. Ensure that the protective device is rated not greater than 20A. Statement 1005



Warning This unit may have more than one power supply connection. All connections must be removed to de-energize the unit. Statement 1028



Warning **Restricted Area**

This unit is intended for installation in restricted access areas. A restricted access area can be accessed by skilled, instructed or qualified personnel. Statement 1017



Warning Use copper conductors only. Statement 1025



Warning This equipment must be grounded. Never defeat the ground conductor or operate the equipment in the absence of a suitably installed ground conductor. Contact the appropriate electrical inspection authority or an electrician if you are uncertain that suitable grounding is available. Statement 1024



Warning Hazardous voltage or energy is present on the backplane when the system is operating. Use caution when servicing. Statement 1034



Warning Class 1 laser product. Statement 1008



Warning Class 1 LED product. Statement 1027



Warning Class I and Class 1M Laser

Invisible Laser Radiation. Do not expose users of telescopic optics. Class 1/1M Laser Products. Statement 1055



Warning Invisible laser radiation may be emitted from the end of the unterminated fiber cable or connector. Do not view directly with optical instruments. Viewing the laser output with certain optical instruments (for example, eye loupes, magnifiers, and microscopes) within a distance of 100 mm may pose an eye hazard. Statement 1056



Warning To prevent personal injury or damage to the chassis, never attempt to lift or tilt the chassis using the handles on modules (such as power supplies, fans, or cards); these types of handles are not designed to support the weight of the unit. Statement 1032



Warning To prevent the system from overheating, do not operate it in an area that exceeds the maximum recommended ambient temperature of: 40 degrees C. Statement 1047



Warning To reduce risk of electric shock and fire, a readily accessible two-poled disconnect device must be incorporated in the fixed wiring. Statement 1022



Warning Blank Faceplates and Cover Panels

Blank faceplates and cover panels serve three important functions: they reduce the risk of electric shock and fire; they contain electromagnetic interference (EMI) that might disrupt other equipment; and they direct the flow of cooling air through the chassis. Do not operate the system unless all cards, faceplates, front covers, and rear covers are in place. Statement 1029



Warning Only trained and qualified personnel should be allowed to install, replace, or service this equipment. Statement 1030



Warning This unit might have more than one power supply connection. All connections must be removed to de-energize the unit. Statement 1028



Warning Hazardous network voltages are present in WAN ports regardless of whether power to the unit is OFF or ON. To avoid electric shock, use caution when working near WAN ports. When detaching cables, detach the end away from the unit first. Statement 1026



Warning Before opening the unit, disconnect the telephone-network cables to avoid contact with telephone-network voltages. Statement 1041



Warning Do not use this product near water; for example, near a bath tub, wash bowl, kitchen sink or laundry tub, in a wet basement, or near a swimming pool. Statement 1035



Warning Never install telephone jacks in wet locations unless the jack is specifically designed for wet locations. Statement 1036



Warning No User-Serviceable Parts
No serviceable parts inside. To avoid risk of electric shock, do not open. Statement 1073



Warning Hazardous network voltages may be present in interface ports regardless of whether power to the unit is OFF or ON. To avoid electric shock, before servicing, disconnect cables from the following ports.



Warning Avoid using a telephone (other than a cordless type) during an electrical storm. There may be a remote risk of electric shock from lightning. Statement 1038



Warning To report a gas leak, do not use a telephone in the vicinity of the leak. Statement 1039



Warning Connect the Chassis to Earth Ground
To reduce the risk of electric shock, the chassis of this equipment needs to be connected to permanent earth ground during normal use. Statement 0445



Warning High touch/leakage current – Permanently connected protective earth ground is essential before connecting to Telecommunication Network. Statement 343



Warning Power Terminals, Replace Cover

Hazardous voltage or energy may be present on power terminals. To reduce the risk of electric shock, always replace cover when terminals are not in service and be sure uninsulated conductors are not accessible when cover is in place. Statement 1086



Warning Instructed person is someone who has been instructed and trained by a skilled person and takes the necessary precautions when working with equipment.

Skilled person/Qualified personnel is someone who have training or experience in the equipment technology and understand potential hazards when working with equipment. Statement 1089



Warning Only skilled person should be allowed to install, replace, or service this equipment. Refer to statement 1089 for description of skilled person. Statement 1090



Warning Only instructed person or skilled person should be allowed to install, replace, or service this equipment. Refer to statement 1089 for description of skilled person. Statement 1091

Safety Recommendations

Follow these guidelines to ensure general safety:

- Never attempt to lift an object that might be too heavy for you to lift by yourself.
- Keep the chassis area clear and dust-free during and after installation.
- If you remove the chassis cover, place it in a safe place.
- Keep tools and chassis components away from walk areas.
- Do not wear loose clothing that may get caught in the chassis. Fasten any tie or scarf and roll up sleeves.
- Wear safety glasses when working under conditions that might be hazardous to your eyes.
- Do not perform any action that may create a hazard to people or makes equipment unsafe.

Safety with Electricity



Warning This unit might have more than one power supply connection. All connections must be removed to de-energize the unit. Statement 1028



Warning Avoid Servicing Outdoor Connections During an Electrical Storm

Avoid using or servicing any equipment that has outdoor connections during an electrical storm. There may be a risk of electric shock from lightning. Statement 1088



Warning Installation Instructions

Read the installation instructions before using, installing or connecting the system to the power source. Statement 1004

Follow these guidelines when working on equipment powered by electricity:

- Locate the emergency power-off switch in the room in which you are working. If an electrical accident occurs, you can quickly turn off the power.
- Disconnect all power before doing the following:
 - Installing or removing a chassis
 - Working near power supplies
- Look carefully for possible hazards in your work area, such as moist floors, ungrounded power extension cables, frayed power cords, and missing safety grounds.
- Do not work alone if hazardous conditions exist
- Never assume that power is disconnected from a circuit. Always check
- Never open the enclosure of the internal power supply
- If an electrical accident occurs to another person, proceed as follows:
 - Use caution; do not become a victim yourself
 - Turn off power to the device
 - If possible, send another person to get medical aid. Otherwise, assess the condition of the victim and then call for help
 - Determine if the person needs rescue breathing or external cardiac compressions; then take appropriate action

In addition, use the following guidelines when working with any equipment that is disconnected from a power source but has telephone wiring or other network cabling connections:

- Never install telephone wiring during a lightning storm
- Never install telephone jacks in wet locations unless the jack is specifically designed for it
- Never touch uninsulated telephone wires or terminals unless the telephone line is disconnected at the network interface
- Use caution when installing or modifying telephone lines

- Remove power cables from all installed power supplies before opening the chassis

Prevent Electrostatic Discharge Damage

Electrostatic discharge (ESD) can damage equipment and impair electrical circuitry. It can occur if electronic printed circuit cards are improperly handled and can cause complete or intermittent failures. Always follow these ESD prevention procedures when removing and replacing modules:

- Ensure that the router chassis is electrically connected to the ground.
- Wear an ESD-preventive wrist strap, ensuring that it makes good skin contact. Connect the clip to an unpainted surface of the chassis frame to channel unwanted ESD voltages safely to ground. To guard against ESD damage and shocks, the wrist strap and cord must operate effectively.
- If no wrist strap is available, ground yourself by touching a metal part of the chassis.



Caution For the safety of your equipment, periodically check the resistance value of the anti-static strap. It should be between 1 and 10 megohms (Mohm).

General Site Requirements

This section describes the requirements your site must meet for the safe installation and operation of your router. Ensure that the site is properly prepared before beginning installation. If you are experiencing shutdowns or unusually high errors with your existing equipment, the guidelines provided in this section can also help you isolate the cause of failures and prevent future problems.

General Precautions

Observe the following general precautions when using and working with your Cisco Catalyst 8200 Series Edge Platforms:

- Keep your system components away from radiators and heat sources, and do not block cooling vents.
- Do not spill food or liquids on your system components, and never operate the product in a wet environment.
- Do not push any objects into the openings of your system components. Doing that can cause fire or electric shock by shorting out interior components.
- Position system cables and power supply cables carefully. Route system cables and the power supply cable and plug so that they cannot be stepped on or tripped over. Be sure that nothing else rests on your system component cables or power cable.
- Do not modify power cables or plugs. Consult a licensed electrician or your power company for electrical modifications at your site. Always follow your local and national wiring rules.
- If you turn off your system, wait at least 30 seconds before turning it on again to avoid system component damage.

Site Selection Guidelines

Cisco Catalyst 8200 Series Edge Platforms require specific environmental operating conditions. Temperature, humidity, altitude, and vibration can affect the performance and reliability of the router. The following sections provide specific information to help you plan for the proper operating environment.

Site Environmental Requirements

Environmental monitoring in the router protects the system and components from damage caused by excessive voltage and temperature conditions. To ensure normal operation and avoid unnecessary maintenance, plan and prepare your site configuration before installation. After installation, ensure the site maintains the required environmental characteristics.

Table 5: Router Environmental Tolerances

Environmental Characteristic	Minimum	Maximum
Steady State Operating	0° C	40° C (40° C at 10,000 feet)
Storage	-20° C	+70° C
Humidity operating (noncondensing)	10%	90%
Humidity nonoperating (noncondensing)	5%	95%
Altitude operating: over allowable temperature range (0 to 40° C)	-500 feet	13,000 feet
Altitude, nonoperating: over allowable temperature range	-500 feet	15,000 feet

Physical Characteristics

Be familiar with the physical characteristics of the Cisco Catalyst 8200 Series Edge Platforms to assist you in placing the system in the proper location.

The height, width, depth and weight of the chassis are displayed in this table:

Characteristic	Measurement
Height	1.73 inches (4.39 cm) — 1RU rack-mount
Width	17.25 inches (43.815 cm)
Depth	11.8 inches (29.972cm)
Weight	10.80 lbs. (4.9 kg)

For more information on the physical characteristics of Cisco Catalyst 8200 Series Edge Platforms, refer to the datasheet for the Cisco Catalyst 8200 Series Edge Platforms.

Rack Requirements

The Cisco Catalyst 8200 Series Edge Platforms is designed for use with a 19-inch rack.

The following information can help you plan your equipment rack configuration:

- Allow clearance around the rack for maintenance.
- Enclosed racks must have adequate ventilation. Ensure that the rack is not congested, because each device generates heat. An enclosed rack should have louvered sides and a fan to provide cooling air. Heat generated by equipment at the bottom of the rack can be drawn upward into the intake ports of the equipment above it.

Power Guidelines and Requirements

Check the power at your site to ensure that you are receiving “clean” power (free of spikes and noise). Install a power conditioner if necessary.

The AC power supply includes the following features:

- Autoselects either 110 V or 220 V operation.
- All units include a 6-foot (1.8-meter) electrical power cord. (A label near the power inlet indicates the correct voltage, frequency [only AC-powered systems], current draw, and power dissipation for the unit.)

For additional information on the power requirements, refer to the Cisco Catalyst 8200 Series Edge Platforms datasheet.

Network Cabling Specifications

The following sections describe the cables required to install your Cisco Catalyst 8200 Series Edge Platforms:

Console Port Considerations

This device includes an asynchronous serial console port. You access to the device locally using a console terminal connected to the console port. This section discusses important cabling information that you must consider before connecting the device to a console terminal.

Flow control paces the transmission of data between a sending and a receiving device. Flow control ensures that the receiving device can absorb the data sent to it before the sending device sends more data. When the buffers on the receiving device are full, a message is sent to the sending device to suspend transmission until the data in the buffers is processed. Console terminals send data at speeds slower than the speeds modems do; therefore, the console port is ideally suited for use with console terminals.



Note Cisco Catalyst 8200 Series Edge Platforms have both EIA/TIA-232 asynchronous (RJ-45) and USB 5-pin mini Type B, 2.0 compliant serial console ports. Shielded USB cables with properly terminated shields are recommended.

EIA/TIA-232

Depending on the cable and the adapter used, this port appears as a DTE or DCE device at the end of the cable. At a time, only one port can be used.

The default parameters for the console port are 9600 baud, 8 data bits, 1 stop bit, and no parity. The console port does not support hardware flow control.

Prepare for Network Connections

When setting up your device, consider distance limitations and potential electromagnetic interference (EMI) as defined by the applicable local and international regulations.



Danger

To avoid electric shock, do not connect safety extra-low voltage (SELV) circuits to telephone-network voltage (TNV) circuits. LAN ports contain SELV circuits, and WAN ports contain TNV circuits. Some LAN and WAN ports both use RJ-45 connectors. Statement 1021

Ethernet Connections

The IEEE has established the Ethernet IEEE 802.3 Standards. The devices support the following Ethernet implementations:

- 1000BASE-T—1000 Mb/s full-duplex transmission over a Category 5 or better unshielded twisted-pair (UTP) cable. Supports the Ethernet maximum length of 328 feet (100 meters).
- 100BASE-T—100 Mb/s full-duplex transmission over a Category 5 or better unshielded twisted-pair (UTP) cable. Supports the Ethernet maximum length of 328 feet (100 meters).
- 10BASE-T—10 Mb/s full-duplex transmission over a Category 5 or better unshielded twisted-pair (UTP) cable. Supports the Ethernet maximum length of 328 feet (100 meters).

Required Tools and Equipment for Installation and Maintenance



Warning

Only trained and qualified personnel should be allowed to install, replace, or service this equipment. Statement 1030



Warning

Instructed and Skilled Person Definitions

Instructed person is someone who has been instructed and trained by a skilled person and takes the necessary precautions when working with equipment. Skilled person/Qualified person is someone who has training or experience in the equipment technology and understand potential hazards when working with equipment. Statement 1089



Warning Instructed and Skilled Person Definitions

Instructed person is someone who has been instructed and trained by a skilled person and takes the necessary precautions when working with equipment. Skilled person/Qualified personnel is someone who has training or experience in the equipment technology and understand potential hazards when working with equipment. Statement 1090



Warning Instructed and Skilled Person Definitions

Instructed person is someone who has been instructed and trained by a skilled person and takes the necessary precautions when working with equipment. Skilled person/Qualified personnel is someone who has training or experience in the equipment technology and understand potential hazards when working with equipment. Statement 1091

You need the following tools and equipment to install and upgrade the router and its components:

- ESD-preventive cord and wrist strap
- Number 2 Phillips screwdriver
- Phillips screwdrivers: small, 3/16-in. (4 to 5 mm) and medium, 1/4-in. (6 to 7 mm)
 - To install or remove modules
 - To remove the cover, if you are upgrading memory or other components
- Screws that fit your rack
- Wire crimper
- Wire for connecting the chassis to an earth ground:
 - AWG 6 (13 mm²) wire for NEBS-compliant chassis grounding
 - AWG 14 (2 mm²) or larger wire for NEC-compliant chassis grounding
 - AWG 18 (1 mm²) or larger wire for EN/IEC 60950-compliant chassis grounding
- For NEC-compliant grounding, an appropriate user-supplied ring terminal, with an inner diameter of 1/4 in. (5 to 7 mm)

In addition, depending on the type of modules you plan to use, you might need the following equipment to connect a port to an external network:

- Cables for connection to the WAN and LAN ports (dependent on configuration)
- Ethernet hub or PC with a network interface card for connection to an Ethernet (LAN) port.
- Console terminal (an ASCII terminal or a PC running HyperTerminal or similar terminal emulation software) configured for 9600 baud, 8 data bits, 1 stop bit, no flow control, and no parity.
- Modem for connection to the auxiliary port for remote administrative access (optional).

- Data service unit (DSU) or channel service unit/data service unit (CSU/DSU) as appropriate for serial interfaces.
- External CSU for any CT1/PRI modules without a built-in CSU.



CHAPTER 3

Install and Connect

This chapter describes how to install and connect the Cisco Catalyst 8200 Series Edge Platforms to WAN, and Voice networks.

The following sections provide the technical details:

- [Safety Warnings, on page 23](#)
- [What You Need to Know, on page 24](#)
- [Before You Begin, on page 25](#)
- [Unpack the Device, on page 25](#)
- [Install the Device, on page 25](#)
- [Connect Power to the Device, on page 36](#)
- [Overview of the Power Options, on page 37](#)
- [Connect to a Console Terminal or Modem, on page 38](#)
- [Connect WAN Interfaces, on page 40](#)

Safety Warnings



Warning High touch/leakage current – Permanently connected protective earth ground is essential before connecting to telecommunication network.



Warning Class 1 laser product. Statement 1008



Warning To reduce the risk of electric shock, the chassis of this equipment needs to be connected to permanent earth ground during normal use. Statement 0445



Warning To reduce risk of electric shock and fire, a readily accessible two-poled disconnect device must be incorporated in the fixed wiring. Statement 1022



Warning Only trained and qualified personnel should be allowed to install, replace, or service this equipment. Statement 1030



Warning Invisible laser radiation may be emitted from disconnected fibers or connectors. Do not stare into beams or view directly with optical instruments. Statement 1051



Warning Invisible laser radiation may be emitted from the end of the unterminated fiber cable or connector. Do not view directly with optical instruments. Viewing the laser output with certain optical instruments (for example, eye loupes, magnifiers, and microscopes) within a distance of 100 mm may pose an eye hazard. Statement 1056



Warning Only instructed person or skilled person should be allowed to install, replace, or service this equipment. Refer to statement 1089 for description of skilled person.



Warning Only instructed person or skilled person should be allowed to install, replace, or service this equipment. Refer to statement 1089 for description of skilled person. Statement 1090



Warning Only instructed person or skilled person should be allowed to install, replace, or service this equipment. Refer to statement 1089 for description of skilled person. Statement 1091



Warning Pluggable optical modules comply with IEC 60825-1 Ed. 3 and 21 CFR 1040.10 and 1040.11 with or without exception for conformance with IEC 60825-1 Ed. 3 as described in Laser Notice No. 56, dated May 8, 2019.. Statement 1255

What You Need to Know

CLI Console Access

Use the USB or RJ-45 console port on the router to access the Cisco Internet Operating System (IOS-XE) and XE SD-WAN command line interface (CLI) on the router and perform configuration tasks. A terminal emulation program is required to establish communication between the router and a PC. See the Connect to a Console Terminal or Modem section in this document for instructions.



Note A Microsoft Windows USB driver must be installed before you establish physical connectivity between the router and the PC.

Software Licenses

To use all the features on the router, you must purchase a software package. For more information on software licenses, see the “Smart Licensing” section of the Software Configuration Guide.

Before You Begin

Before installing and connecting Cisco Catalyst 8200 Series Edge Platforms, read the safety warnings and gather the following tools and equipment. For more information about the required tools and equipments, see the tools and equipment section.

Unpack the Device

Do not unpack the device until you are ready to install it. If the final installation site will not be ready for some time, keep the chassis in its shipping container to prevent accidental damage. When you are ready to install the chassis, proceed with unpacking it.

The chassis, accessory kit, publications, and any optional equipment you ordered may be shipped in more than one container. When you unpack the containers, check the packing list to ensure that you received all of the items on the list.

Install the Device

If you need to install Network Interface Modules (NIMs), Pluggable Interface Modules (PIMs), and Field-Replaceable Units (FRUs) on the Cisco Catalyst 8200 Series Edge Platforms devices, then, you can install them either before or after you install the device. Ideally, you can install these modules when you have access to the I/O side of the device. Internal modules, memory cards and fan trays should be installed before rack-mounting the device.

You can install the device in one of the following ways:

- Set the chassis on a desktop
- Attach the chassis to the wall
- Mount the chassis on a rack



Warning Before working on a system that has an on/off switch, turn OFF the power and unplug the power cord that is in the chassis. Statement 1

Mount the Chassis on a Desktop



Warning To prevent personal injury or damage to the chassis, never attempt to lift or tilt the chassis using the handles on modules (such as power supplies, fans, or cards); these types of handles are not designed to support the weight of the unit. Statement 1032

The Cisco Catalyst 8200 Series Edge Platforms have circular markings on the bottom of the chassis for rubber feet. Apply the rubber feet when installing the router on horizontal surface (desk or shelf).

Figure 7: Applying Rubber Feet to the Router

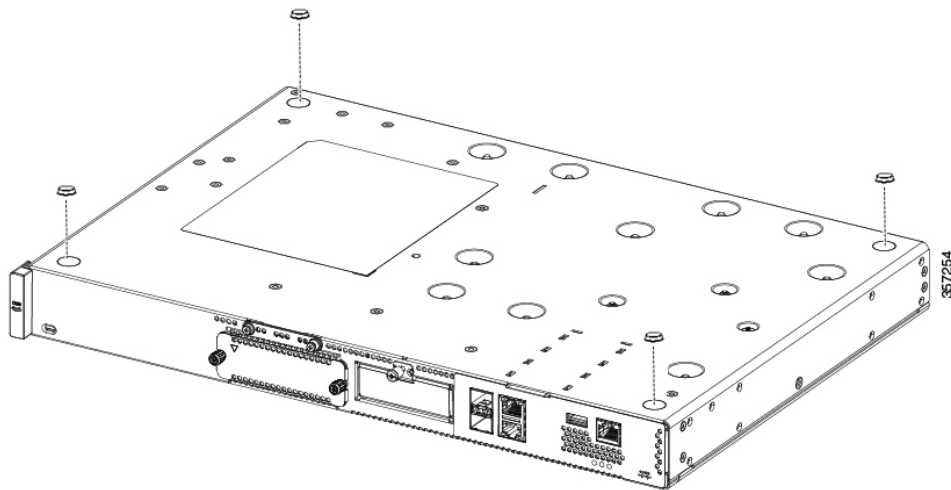

Note Do not set the chassis in an area where the moderate acoustic noise can be an issue.



Caution Do not place anything on top of the device that weighs more than 10 pounds (4.5 kg), and do not stack device on a desktop. Excessive distributed weight of more than 10 pounds, or pound point load of 10 pounds on top could damage the chassis.



Caution Your chassis installation must allow unrestricted airflow for chassis cooling. For placing the device on a desktop, keep at least 1 inch (2.54 cm) of clear space beside the cooling inlet and exhaust vents.

After the device is installed, you must connect the chassis to a reliable earth ground. For the chassis ground connection procedures, see the Chassis Grounding section.

Rack Mount the Chassis



Warning Supply Circuit

To reduce risk of electric shock and fire, take care when connecting units to the supply circuit so that wiring is not overloaded. Statement 1018



Warning This equipment must be grounded. Never defeat the ground conductor or operate the equipment in the absence of a suitably installed ground conductor. Contact the appropriate electrical inspection authority or an electrician if you are uncertain that suitable grounding is available. Statement 1024

Warning To prevent the system from overheating, do not operate it in an area that exceeds the maximum recommended ambient temperature of: 40 degrees C. Statement 1047

The Catalyst 8200 Series Edge Platforms can be installed in 19-inch (48.26-cm) racks. You can order the standard brackets for mounting the chassis in a 19-inch EIA rack.

The mounting ears for the device are designed for #12-24 UNC screws for rack mounting.

You can rack-mount the device in the following ways:

- I/O-side mounting—Brackets attached at the front of the chassis with the front panel facing forward
- Power-input side mounting—Brackets attached at the back of the chassis with the back panel facing forward

Attach the Rack-Mounting Brackets



Caution Do not over-torque the screws. The recommended torque is 15 to 18 inch-lbs (1.7 to 2.0 N-m).

Caution Your chassis installation must allow unrestricted airflow for chassis cooling.

Attach the mounting brackets to the chassis as shown in the below figure using the screws provided. Use a #2 Philips screwdriver.

To attach the rack-mounting brackets to the Cisco 8200 Series device, perform these steps:

- Step 1** Select the mounting orientation for the router in the equipment rack. I/O- side (recessed to allow space for the RFID badge) or power-input side (flush).
- Step 2** Align the rack mount bracket with the mounting holes in the side of the device.
- Step 3** Insert the #6-32 FHM screws. Use only the screws that are provided in the rack mount bracket kit.
- Step 4** Tighten the screws to a torque value of 15 to 18 inch-lb. (1.7 to 2.0 N-m).

Figure 8: Bracket Installation for I/O Side Mounting

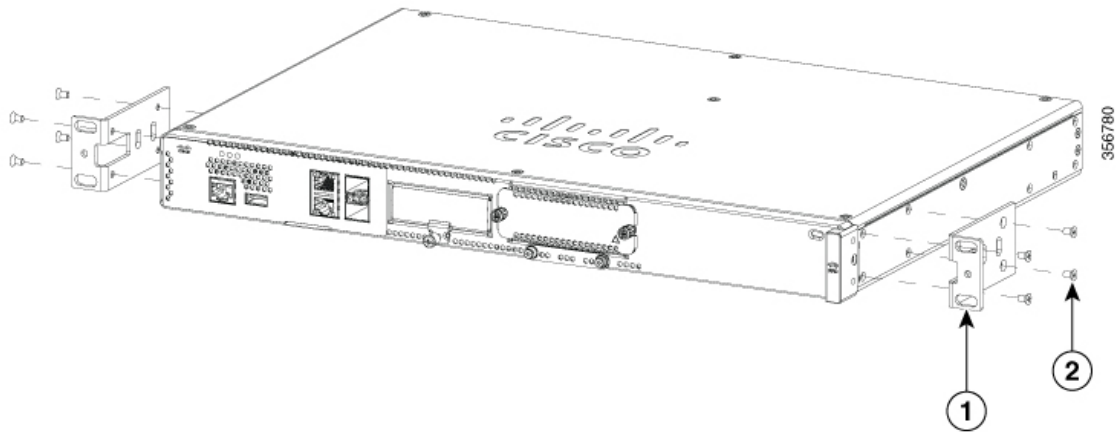

1	Rack Mounting brackets
2	Mounting screws

Figure 9: Bracket Installation on Power-input Side Mounting

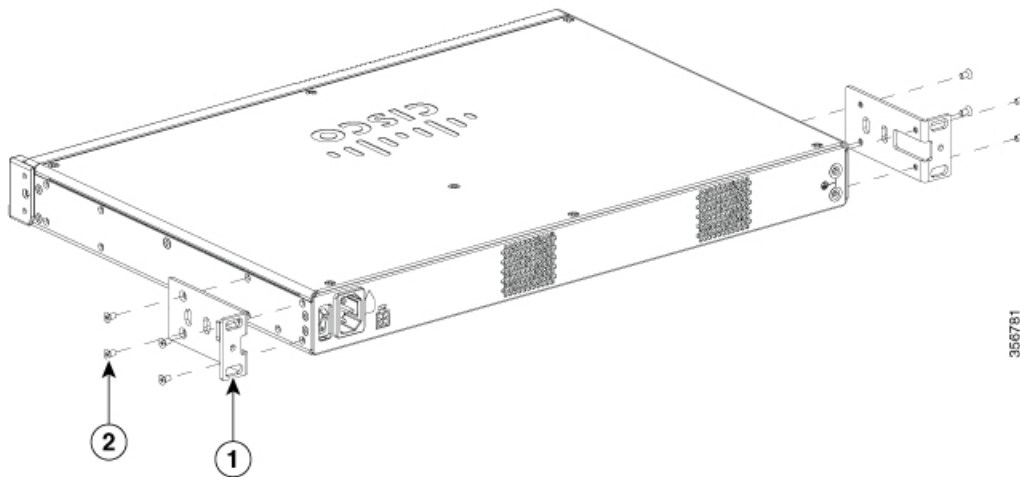

1	Rack Mounting brackets
2	Mounting screws

Mount the Chassis on a Rack

After you attach the brackets to the device, install the chassis on the rack as shown in following figures. You need two screws to attach each bracket to the rack. Total four screws are required to attach the device to the rack. The screws for attaching the device to the rack are not provided with the kit.



Tip For the 19-inch EIA brackets, start the lower pair of screws first, and rest the brackets on the lower screws while you insert the upper pair of screws.



Tip The screw slots in the brackets are spaced to line up with every *second* pair of screw holes in the rack. When the correct screw holes are used, the small threaded holes in the brackets line up with unused screw holes in the rack. If the small holes do not line up with the rack holes, you must raise or lower the brackets to the next rack hole.



Warning To prevent bodily injury when mounting or servicing this unit in a rack, you must take special precautions to ensure that the system remains stable. The following guidelines are provided to ensure your safety:

- This unit should be mounted at the bottom of the rack if it is the only unit in the rack.
 - When mounting this unit in a partially filled rack, load the rack from the bottom to the top with the heaviest component at the bottom of the rack.
 - If the rack is provided with stabilizing devices, install the stabilizers before mounting or servicing the unit in the rack. Statement 1006.
-



Warning To prevent personal injury or damage to the chassis, never attempt to lift or tilt the chassis using the handles on modules (such as power supplies, fans, or cards); these types of handles are not designed to support the weight of the unit. Statement 1032

Figures below shows a typical rack mounting of a chassis in a rack.

Step1. Locate the desired position in the equipment rack.

Step2. Align the holes in the rack mount brackets with the mounting holes in the equipment frame.

Step3. Secure the device using mounting screws appropriate for your equipment frame. The rack mount brackets have been designed #12-24 PHM screws.

Step4. Tighten the screws to the appropriate torque value for your equipment

Mount the Chassis on a Rack

Figure 10: Mounting the Chassis on the Rack – I/O-Side (Cisco 8200 Series Chassis)

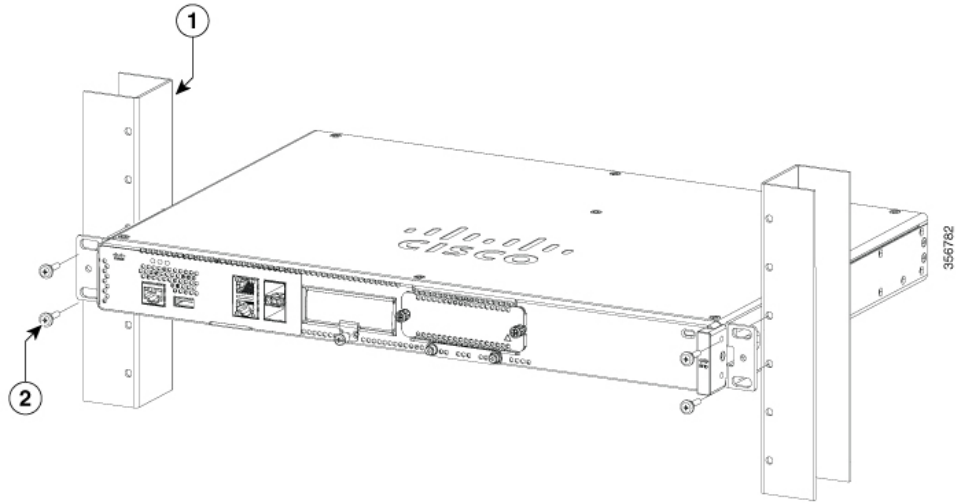

1	Rack
2	Rack Mounting screws

Figure 11: Mount the chassis on the rack - Power-input Side (Cisco 8200 Series Chassis)

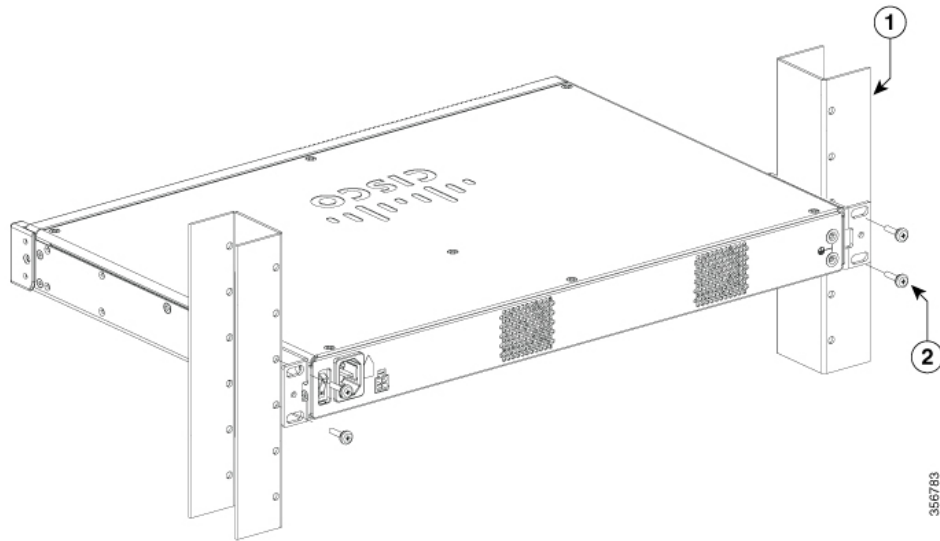

1	Rack
1	Rack Mounting screws

Attach Cisco Catalyst 8200 Series Edge Platforms on a Wall



Caution When mounted on a wall, the Catalyst 8200 Series Edge Platforms should always be oriented with a side of the device oriented in the downward position. The I/O side and power-input side should be oriented so that the fan vents and cable entry will be oriented to the left or right. Neither the I/O side nor Power-input side should ever be oriented downwards.



Caution Your chassis installation must allow unrestricted airflow for chassis cooling.

Step 1 Attach the rack mount brackets to the sides of the device using only the hardware provided in the wall mounting kit (#6-32 x 0.44 inch PHMS).

Step 2 The outer face of the rack mount bracket ear, the part that typically mounts to an equipment rack, should be placed against the side of the router. Use the spacers provided to adapt the larger obround holes down to smaller holes for the screws to fit into.

Step 3 The brackets should be located diagonally from each other as shown in the figure below.

Step 4 Tighten the screws to a torque value of 15 to 18 inch-lb. (1.7 to 2.0 N-m).

Step 5 Use #6 or 4mm hardware to secure the brackets to the wall; at least 2 per bracket. Securing hardware should be a minimum of 1 inch in length (25.4 mm).



Note The customer must supply the appropriate hardware for securing the mounting brackets to the wall. Each mounting bracket has 4 holes and 2 slots that may be used for mounting the brackets to the wall.

Step 6 Route the cables so that they do not put a strain on the connectors or mounting hardware.

Figure 12: Attach Wall Mount Brackets (Cisco 8200 Series Chassis)

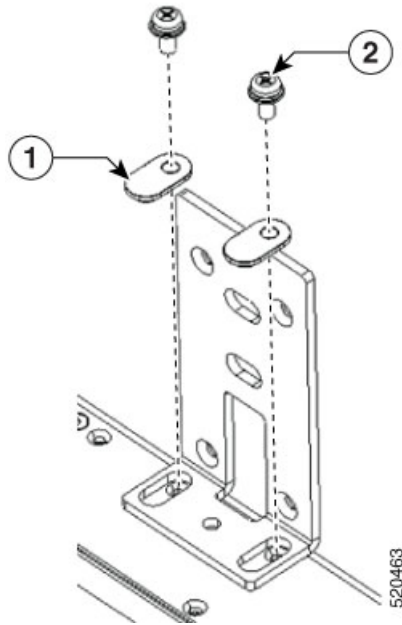

1	Bracket slot spacer for screw. Orient spacer in slot as shown.
2	Screws

Figure 13: Wall Mount the Cisco 8200 Series Chassis

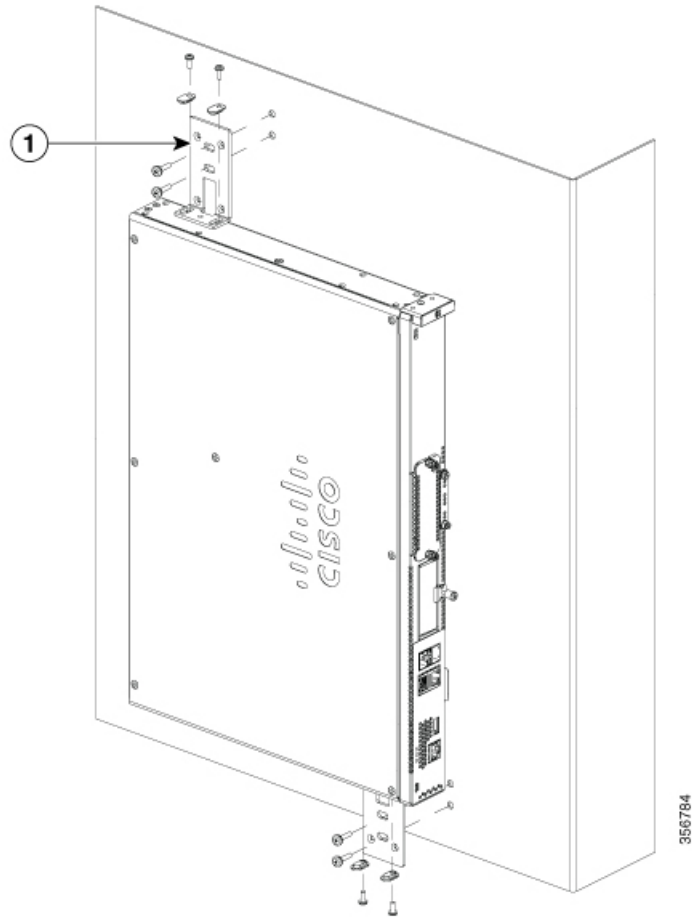

1	Wall-mount bracket against wall
---	---------------------------------

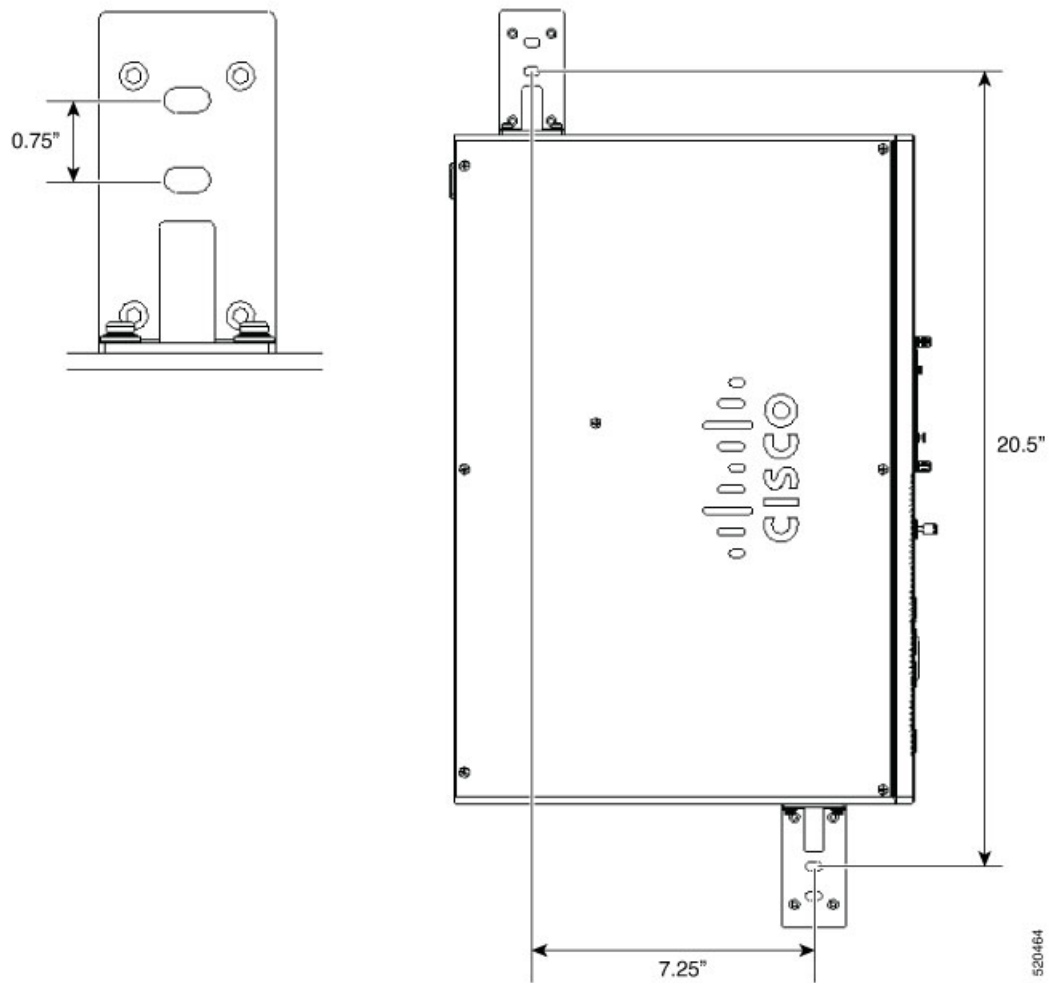

Ground the Chassis

After the device is installed, you must connect the chassis to a reliable earth ground.

Chassis Grounding



Warning This equipment must be grounded. Never defeat the ground conductor or operate the equipment in the absence of a suitably installed ground conductor. Contact the appropriate electrical inspection authority or an electrician if you are uncertain that suitable grounding is available. Statement 1024



Warning During this procedure, wear grounding wrist straps to avoid ESD damage to the card. Do not directly touch the backplane with your hand or any metal tool, you could shock yourself. Statement 94

You must connect the chassis to a reliable earth ground; the ground wire must be installed in accordance with local electrical safety standards.

- For grounding, use size 6 AWG (13 mm²) copper wire and the ground lug provided in the accessory kit.



Note This equipment is suitable for installation in Network Telecommunications Facilities and locations where the NEC applies. The equipment is suitable for installation as part of the Common Bonding Network (CBN).

- For NEC-compliant grounding, use size 14 AWG (2 mm²) or larger copper wire and an appropriate user-supplied ring terminal with an inner diameter of 1/4 in. (5–7 mm)
- AWG 10 (4 mm²) or larger wire for EN/IEC 60950-1 and EN/IEC 62368-1 compliant chassis grounding



Note The grounding wire should be sized according to local and national installation requirements. The above recommended AWG values for NEBS-compliant, NEC-compliant, EN/IEC 60950-1 and EN/IEC 62368-1 as the minimum requirement respectively, the higher AWG value recommendation also with the higher priority, this means AWG 10 is the minimum requirement only when NEBS is not required. Commercially available 6-AWG grounding wire is always preferred from the chassis to the rack ground or directly to the common bonding network (CBN). The length of the grounding wire depends on the proximity of the switch to proper grounding facilities.

To install the ground connection for your device, perform the following steps:

Step 1 Strip one end of the ground wire to the length required for the ground lug or terminal.

- For the ground lug—approximately 0.75 inch (20 mm)
- For user-provided ring terminal—as required

Step 2 Crimp the ground wire to the ground lug or ring terminal, using a crimp tool of the appropriate size.

Step 3 Attach the ground lug or ring terminal to the chassis as shown in Chassis Grounding section. For a ground lug, use the two screws with captive locking washers provided. For a ring terminal, use one of the screws provided. Tighten the screws to a torque of 8 to 10 in-lb (0.9 to 1.1 N-m).

Figure 14: Chassis Ground Connection on the Cisco 8200 Series Chassis

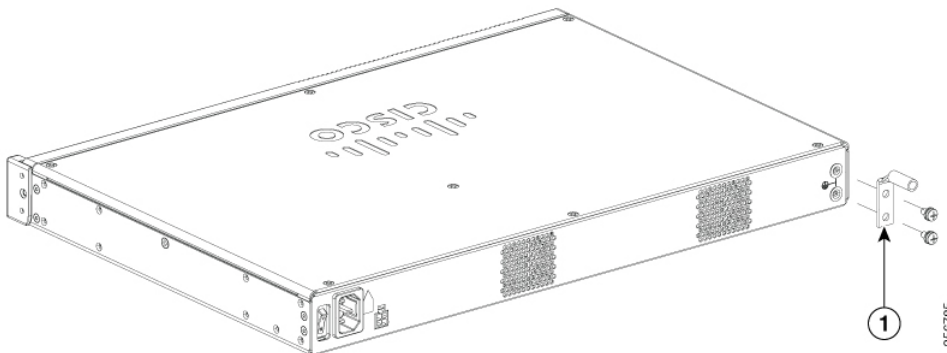

1	Ground lug
---	------------

Step 4 Connect the other end of the ground wire to a known reliable earth ground point at your site.

Connect Power to the Device

This section explains how to connect power to the device.



Warning Read the installation instructions before connecting the system to the power source. Statement 1004



Warning This unit might have more than one power supply connection. All connections must be removed to de-energize the unit. Statement 1028



Warning Only trained and qualified personnel should be allowed to install, replace, or service this equipment. Statement 1030



Note The installation must comply with all required electrical codes applicable at the installation site.



Warning When installing the product, please use the provided or designated connection cables/power cables/AC adaptors. Using any other cables/adaptors could cause a malfunction or a fire. Electrical Appliance and Material Safety Law prohibits the use of UL-certified cables (that have the “UL” shown on the code) for any other electrical devices than products designated by CISCO. The use of cables that are certified by Electrical Appliance and Material Safety Law (that have “PSE” shown on the code) is not limited to CISCO-designated products. Statement 371.

If your device uses AC power, connect it to a 15 A, 120 VAC (10 A, 240 VAC) circuit with overcurrent protection.



Note The input voltage tolerance limits for AC power are 90 and 264 VAC.



Note This product requires surge protection to be provided as part of the building installation. To comply with the Telcordia GR-1089 NEBS standard for electromagnetic compatibility and safety, an external surge protective device (SPD) is required at the AC power service equipment.

**Warning**

This product relies on the building's installation for short-circuit (overcurrent) protection. Ensure that the protective device is rated not greater than 20A. Statement 1005

Overview of the Power Options

The Powering options for the Cisco Catalyst 8200 Series Edge devices are as follows:

- 100W internal PSU (not field upgradeable). Powers the full router with standard AC cord. Always provided.
- 150W external POE adapter. Optional power input when POE output or modules is required.

Powering On the Server

An external POE supply may be ordered if required. The table below shows the physical parameters depending on the supplier.



Note The POE supply provided may be of different sizes.

PSU	Delta PSU	FSP PSU
Main Part Dimensions	L-200 * W-100 * H-43 mm	L-177 * W-86 * H-32.2 mm
Weight	1.015 KG	0.575 KG

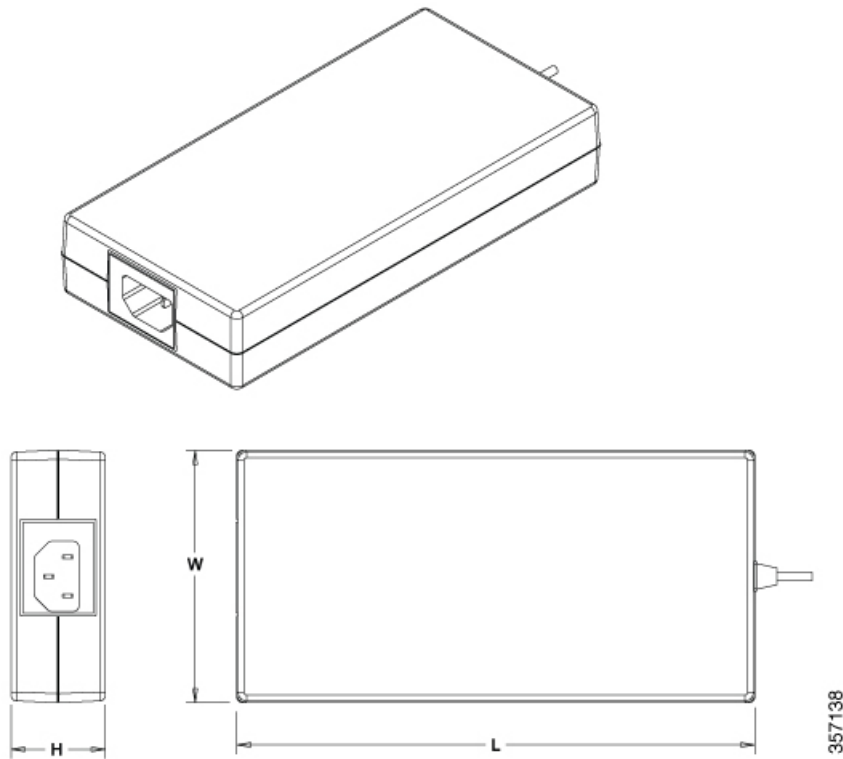

Connect to a Console Terminal or Modem

The Cisco Catalyst 8200 Series Edge Platforms have asynchronous serial ports. These ports provide administrative access to the router either locally (with a console terminal or a PC). To configure the router through the Cisco IOS CLI, you must establish a connection between the router console port and either a terminal or a PC.

Use the following cables and adapters to establish a local or remote connection.

Figure 15: Local and Remote Connections

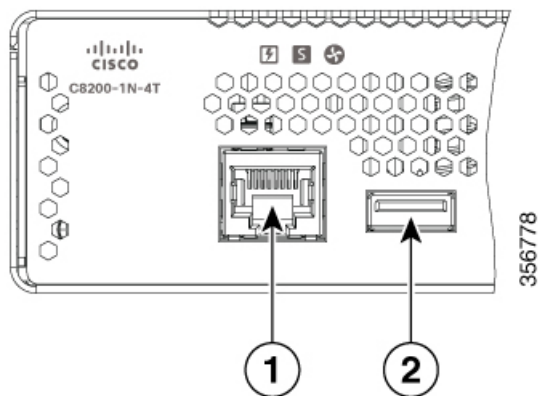

Port Type	Cable	Section
1. Serial (RJ-45)	EIA RJ-45	Connect to the Serial Port with Microsoft Windows

Connect to the Console Port with Mac OS X

This procedure describes how to connect a Mac OS X system USB port to the console using the built in OS X Terminal utility.

- Step 1** Use the Finder to go to Applications > Utilities > Terminal.
- Step 2** Connect the OS X USB port to the router.
- Step 3** Enter the following commands to find the OS X USB port number

Example:

```
macbook:user$ cd /dev
macbook:user$ ls -ltr /dev/*usb*
crw-rw-rw-  1 root   wheel      9,  66 Apr  1 16:46 tty.usbmodem1a21 DT-macbook:dev user$
```

- Step 4** Connect to the USB port with the following command followed by the router USB port speed

Example:

```
macbook:user$ screen /dev/tty.usbmodem1a21 9600
```

To disconnect the OS X USB console from the Terminal window

Enter Ctrl-a followed by Ctrl-\

Connect to the Console Port with Linux

This procedure shows how to connect a Linux system USB port to the console using the built in Linux Terminal utility.

- Step 1** Open the Linux Terminal window.
- Step 2** Connect the Linux USB port to the router.
- Step 3** Enter the following commands to find the Linux USB port number

Example:

```
root@usb-suse# cd /dev
root@usb-suse /dev# ls -ltr *ACM*
crw-r--r--  1 root   root      188,   0 Jan 14 18:02 ttyACM0
root@usb-suse /dev#
```

- Step 4** Connect to the USB port with the following command followed by the router USB port speed

Example:

```
root@usb-suse /dev# screen /dev/ttyACM0 9600
```

To disconnect the Linux USB console from the Terminal window

Enter Ctrl-a followed by : then quit

Connect WAN Interfaces

This section describes how to connect WAN interface cables. Before you connect the interface cables, refer to the following warning statements:



Warning Never install telephone jacks in wet locations unless the jack is specifically designed for wet locations. Statement 1036.



Warning Never touch uninsulated telephone wires or terminals unless the telephone line has been disconnected at the network interface. Statement 1037.



Warning For connections outside the building where the equipment is installed, the following ports must be connected through an approved network termination unit with integral circuit protection, LAN, PoE. Statement 1044.



Warning Avoid using or servicing any equipment that has outdoor connections during an electrical storm. There may be a risk of electric shock from lightning. Statement 1088.

Ports and Cabling

The connections summarized here are also described in detail in the document on Cisco.com: Cisco Modular Access Cable Specifications

Table 6: WAN and Voice Connections

Port or Connection	Port Type, Color ¹	Connection:	Cable
Ethernet	RJ-45, yellow	Ethernet hub or Ethernet switch	Category 5 or higher Ethernet
T1/E1 WANxCE1T1-PRI	RJ-48C/CA81ARJ-48S, tan	T1 or E1 networkExternal T1 CSU or other T1 equipment	RJ-48 T1/E1RJ-48S to RJ-48S TERJ-48S to RJ-48S NTRJ-48S to RJ-48S T1RJ-48S to bareRJ-48S to BNCRJ-48S to twinaxial cableRJ-48S to DB-15RJ-48S to DB-15 null

Port or Connection	Port Type, Color ¹	Connection:	Cable
T3/DS3/E3 WAN	BNC connector	T3 network, CSU/DSU, or other T3/DS3 equipment	75-ohm coaxial cable
Cisco serial	60-pin D-sub, blue	CSU/DSU and serial network or equipment	Cisco serial transition cable that matches the signaling protocol (EIA/TIA-232, EIA/TIA-449, V.35, X.21, or EIA-530) and the serial port operating mode (DTE or DCE). ²
Cisco Smart serial	Cisco Smart compact connector, blue	CSU/DSU and serial network or equipment	
Gigabit Ethernet SFP, optical	LC, color according to optical wavelength	1000BASE-SX, -LX, -LH, -ZX, -CWDM	Optical fiber as specified on applicable data sheet
Gigabit Ethernet SFP, copper	RJ-45	1000BASE-T	Category 5, 5e, 6 UTP

¹ Cable color codes are specific to Cisco cables.

² See the Cisco Modular Access Router Cable Specifications document for information about choosing these cables.

General Precautions

Observe the following general precautions when using and working with your Cisco Catalyst 8200 Series Edge Platforms:

- Keep your system components away from radiators and heat sources, and do not block cooling vents.
- Do not spill food or liquids on your system components, and never operate the product in a wet environment.
- Do not push any objects into the openings of your system components. Doing that can cause fire or electric shock by shorting out interior components.
- Position system cables and power supply cables carefully. Route system cables and the power supply cable and plug so that they cannot be stepped on or tripped over. Be sure that nothing else rests on your system component cables or power cable.
- Do not modify power cables or plugs. Consult a licensed electrician or your power company for electrical modifications at your site. Always follow your local and national wiring rules.
- If you turn off your system, wait at least 30 seconds before turning it on again to avoid system component damage.



CHAPTER 4

Install Internal Components and Field Replaceable Units

This document describes how to install internal components and field replaceable units (FRUs) in the Cisco Catalyst 8200 Series Edge Platforms. The installation information is contained in these sections:

- [Safety Warnings, on page 43](#)
- [Locate and Access Internal Components, on page 44](#)
- [Remove and Replace DDR DIMMs, on page 46](#)
- [Install and Remove SFP Modules, on page 49](#)
- [Remove and Replace the USB Flash Token Memory Stick, on page 52](#)
- [Remove and Install an M.2 USB|NVMe Module, on page 52](#)
- [Remove the M.2 USB|NVMe Module, on page 53](#)
- [Install the M.2 USB|NVMe Module, on page 54](#)

Safety Warnings



Warning High touch/leakage current – Permanently connected protective earth ground is essential before connecting to telecommunication network.



Warning Class 1 laser product. Statement 1008



Warning To reduce the risk of electric shock, the chassis of this equipment needs to be connected to permanent earth ground during normal use. Statement 0445



Warning To reduce risk of electric shock and fire, a readily accessible two-poled disconnect device must be incorporated in the fixed wiring. Statement 1022



Warning Only trained and qualified personnel should be allowed to install, replace, or service this equipment. Statement 1030



Warning Invisible laser radiation may be emitted from disconnected fibers or connectors. Do not stare into beams or view directly with optical instruments. Statement 1051



Warning Invisible laser radiation may be emitted from the end of the unterminated fiber cable or connector. Do not view directly with optical instruments. Viewing the laser output with certain optical instruments (for example, eye loupes, magnifiers, and microscopes) within a distance of 100 mm may pose an eye hazard. Statement 1056



Warning Only instructed person or skilled person should be allowed to install, replace, or service this equipment. Refer to statement 1089 for description of skilled person.



Warning Only instructed person or skilled person should be allowed to install, replace, or service this equipment. Refer to statement 1089 for description of skilled person. Statement 1090



Warning Only instructed person or skilled person should be allowed to install, replace, or service this equipment. Refer to statement 1089 for description of skilled person. Statement 1091



Warning Pluggable optical modules comply with IEC 60825-1 Ed. 3 and 21 CFR 1040.10 and 1040.11 with or without exception for conformance with IEC 60825-1 Ed. 3 as described in Laser Notice No. 56, dated May 8, 2019.. Statement 1255

Locate and Access Internal Components

The figures below show the locations of internal components on the motherboard. Internal modules include DIMMs on Cisco Catalyst 8200 Series Edge Platforms.

To access the internal components on the device, you must first remove the chassis cover. For instructions on how to remove and replace the chassis cover on the device, see the sections on Install and Remove Chassis Covers.

Figure 16: Internal Component Location in the Cisco 8200 Series Chassis

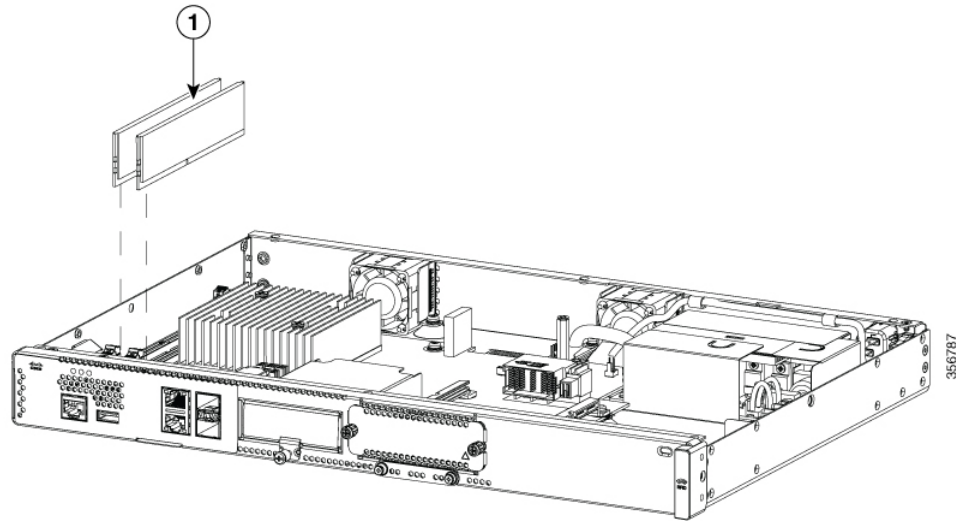

Sl. No	Modules
1	DIMMs

Remove and Replace the Chassis Cover

The Cisco Catalyst 8200 Series Edge Platforms have removable covers. Before removing the cover, do these steps:

- Do not run the device with the cover off. Doing so can cause the chassis to overheat very quickly.
- Before opening the unit, disconnect the telephone-network cables to avoid contact with telephone-network voltages. Statement 1041.
- Disconnect all power cables.
- Remove the device from the rack

Use a number-2 Phillips screwdriver to perform the following tasks.

Remove the Cover

To remove the cover, perform the following steps.

-
- Step 1** Read the Safety Warnings and disconnect the power supply before you perform any module replacement.
- Step 2** Confirm the device is turned off and disconnected from the power supply or power supplies. If a redundant power is used, disconnect from the redundant power supply.
- Step 3** Place the chassis on a flat surface.
- Step 4** For Catalyst 8200 Series Edge Platforms, remove the 9 cover screws.

Replace the Cover

Step 5 Lift the cover straight up.

Replace the Cover

To replace the cover, perform the following steps.

Step 1 Place the chassis on a flat surface.

Step 2 Drop the cover straight down and ensure that the side flanges insert into the chassis. Care should be taken to not damage the EMC Gaskets.

Step 3 For Catalyst 8200 Series Edge Platforms, install the 9 cover screws.

Figure 17: Install the Cover on the Cisco 8200 Series Chassis

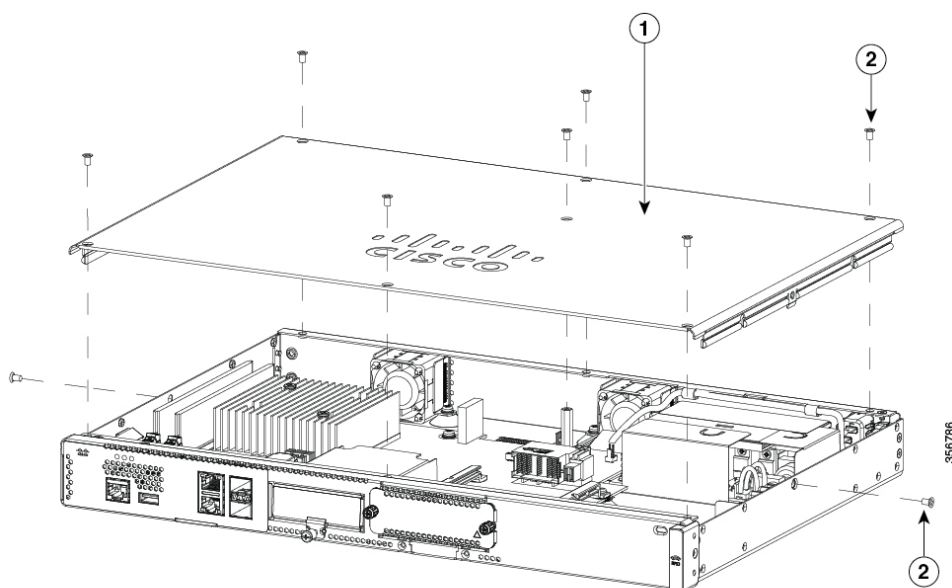

1	Cover
2	Screws

Remove and Replace DDR DIMMs

To access the DIMMs, you must remove the chassis cover as described in the Access and Install Modules section.



Caution Always wear an ESD-preventive wrist strap and ensure that it makes good contact with your skin when you remove or install DIMMs. Connect the equipment end of the wrist strap to the metal part of the chassis.



Caution Handle DIMMs by the edges only. DIMMs are ESD-sensitive components and can be damaged by mishandling.

Locate and Orient DIMM

DIMMs have a polarization notch on the mating edge to prevent incorrect insertion. The following image shows the polarization notch on a DIMM.

Figure 18: DIMM Showing Polarization Notch

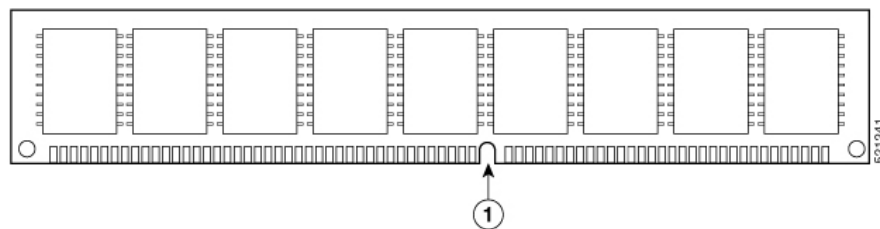

1	Polarization notch
---	--------------------

Remove a DIMM

Follow these steps to remove a DIMM:

-
- Step 1** Read the Safety Warnings section and disconnect the power supply before you perform any module replacement.
 - Step 2** If the cover is not already removed, remove the chassis cover.
 - Step 3** Locate the DIMM module to find the DIMM sockets on the chassis.
 - Step 4** Rotate DIMM connector handles downwards to extract the DIMM module.

Figure 19: Remove a DIMM

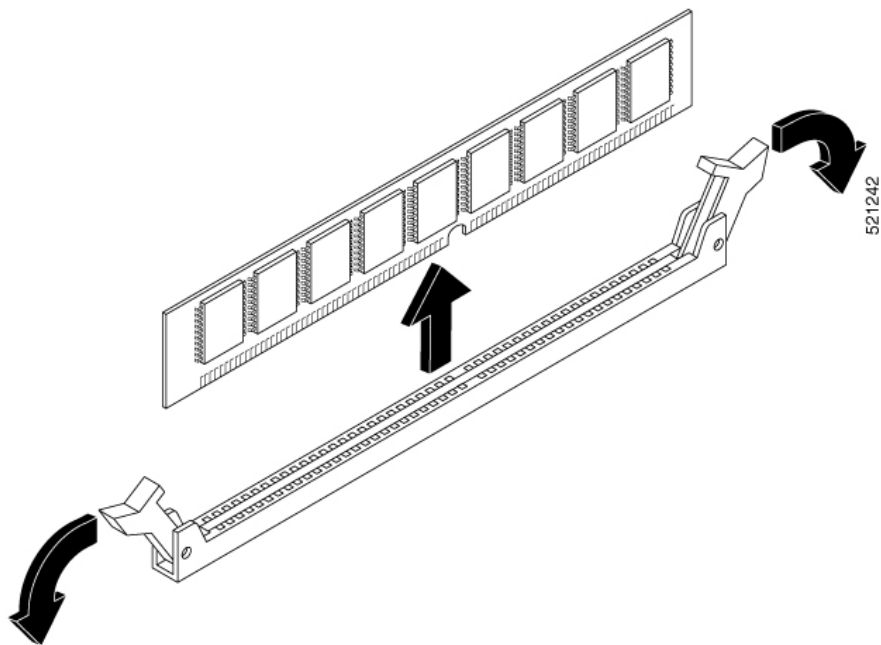

Install a DIMM

Follow these steps to install a DIMM on the Cisco Catalyst 8200 Series Edge Platforms.

- Step 1** Read the Safety Warnings section and disconnect the power supply before you perform any DIMM replacement.
- Step 2** If the cover is not already removed, remove the chassis cover.
- Step 3** Locate the DIMM module to find the DIMM sockets on the device.
- Step 4** Ensure that both latches on the DIMM connector are in the open position.
- Step 5** Orient the DIMM so that the polarization notch lines up with the polarization key on the connector.

Figure 20: DIMM Showing Polarization Notch

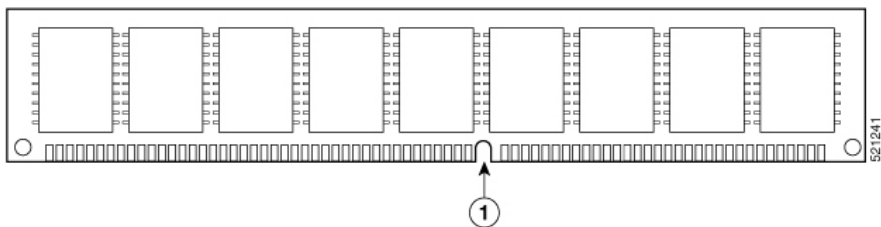

- Step 6** Insert the DIMM into the connector one side at a time.
- Step 7** Rotate the connector handles upward and click into place.
- Step 8** Reinstall the chassis cover.

Figure 21: Install a DIMM

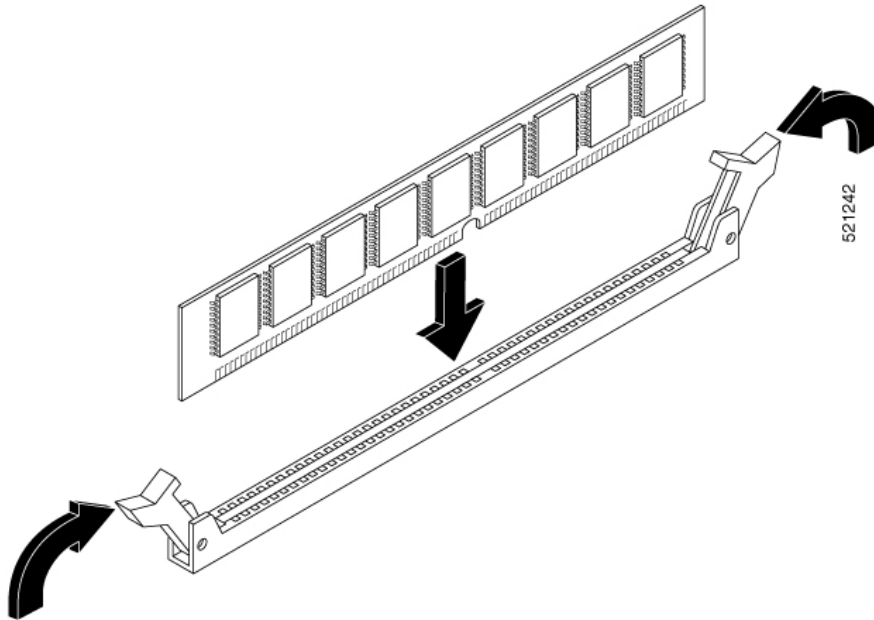

Step 9 Replace the chassis cover.

Install and Remove SFP Modules

Before you begin

See the Cisco Catalyst 8200 Series Edge Platforms's datasheet on cisco.com for a list of supported SFP modules. Use only supported SFP modules on the platform.



Warning Class 1 laser product. Statement 1008

- Do not remove the dust plugs from the SFP modules or the rubber caps from the fiber-optic cable until you are ready to connect the cable. The plugs and caps protect the module ports and cables from contamination and ambient light.
- Removing and installing an SFP module can shorten its useful life. Do not remove and insert any SFP module more often than is necessary.
- To prevent ESD damage, follow your normal board and component handling procedures when connecting cables to the switch and other devices.
- When you insert several SFP modules in multiple ports, wait for 5 seconds between inserting each SFP. This will prevent the ports from going into error disabled mode. Similarly, when you remove an SFP from a port, wait for 5 seconds before reinserting it.

-
- Step 1** Attach an ESD-preventive wrist strap to your wrist and to an earth ground surface.
- Step 2** Find the send (TX) and receive (RX) markings that identify the top of the SFP module.
On some SFP modules, the send and receive (TX and RX) markings might be shown by arrows that show the direction of the connection.
- Step 3** If the SFP module has a bale-clasp latch, move it to the open, unlocked position.
- Step 4** Align the module in front of the slot opening, and push until you feel the connector snap into place.
- Step 5** If the module has a bale-clasp latch, close it to lock the SFP module in place.
- Step 6** Remove the SFP dust plugs and save.
- Step 7** Connect the SFP cables.
-

Laser Safety Guidelines

Optical Small-Form Pluggable (SFPs) use a small laser to generate the fiber-optic signal. Keep the optical transmit and receive ports covered whenever a cable is not connected to the port.



Warning Invisible laser radiation may be emitted from disconnected fibers or connectors. Do not stare into beams or view directly with optical instruments. Statement 1051



Warning Ultimate disposal of this product should be handled according to all national laws and regulations. Statement 1040



Warning Pluggable optical modules comply with IEC 60825-1 Ed. 3 and 21 CFR 1040.10 and 1040.11 with or without exception for conformance with IEC 60825-1 Ed. 3 as described in Laser Notice No. 56, dated May 8, 2019. Statement 1255.

To install an SFP module in your device, perform these steps:

-
- Step 1** Read the Safety Warnings section and disconnect the power supply before you perform any module replacement.
- Step 2** Slide the SFP into the device connector until it locks into position
- Tip** If the SFP uses a bale-clasp latch (see Laser Safety Guidelines section, the handle should be on top of the SFP module.

Figure 22: Install a Small-Form Pluggable Module

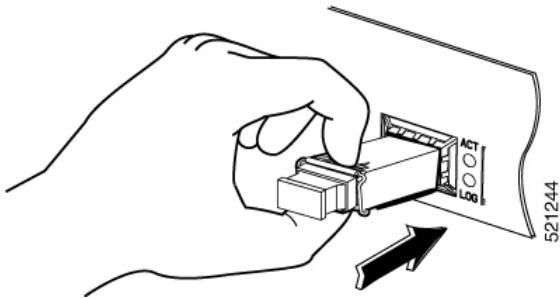

Caution Do not remove the optical port plugs from the SFP until you are ready to connect cabling.

Step 3 Connect the network cable to the SFP module.

Remove Small Form Pluggable Modules

Follow these steps to remove a Small Form Pluggable (SFP) from the device:

Step 1 Read the Safety Warnings section and disconnect the power supply before you perform any module replacement.

Step 2 Disconnect all cables from the SFP.

Warning Invisible laser radiation may be emitted from disconnected fibers or connectors. Do not stare into beams or view directly with optical instruments. Statement 1051

Caution The latching mechanism used on many SFPs locks the SFP into place when cables are connected. Do not pull on the cabling in an attempt to remove the SFP.

Step 3 Disconnect the SFP latch.

Note SFP modules use various latch designs to secure the module in the SFP port. Latch designs are not linked to SFP model or technology type. For information on the SFP technology type and model, see the label on the side of the SFP.

Figure 23: Disconnecting SFP Latch Mechanisms

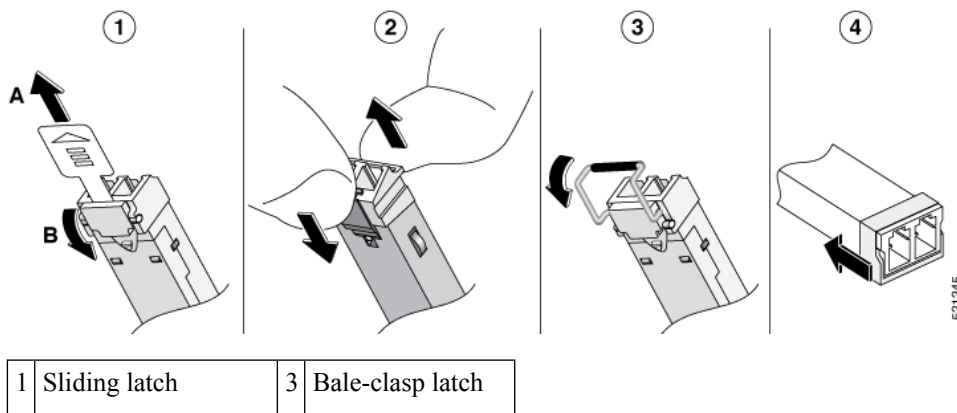

2	Swing and slide latch	4	Plastic collar latch
---	-----------------------	---	----------------------

Tip Use a pen, screwdriver, or other small straight tool to gently release a bale-clasp handle if you cannot reach it with your fingers.

Step 4 Grasp the SFP on both sides and remove it from the device.

Remove and Replace the USB Flash Token Memory Stick

The Cisco Catalyst 8200 Series Edge Platforms contain ports for a USB memory stick to store Cisco configurations or Cisco IOS XE consolidated packages.



Caution Do not remove a USB Flash memory module when issuing some file access command or a read/write operation to the Flash memory module when it is processing. The router might reload or the USB Flash memory module can be damaged. You can check to see if the USB activity LED on the router front panel is flashing, prior to the removal of the USB device

To install, remove a USB memory stick from the device, follow these steps:

Step 1 Place the USB stick into the USB port.

Step 2 Type-C memory sticks are supported on USB port 1 and type-C memory can be inserted in any direction. Type-A memory sticks are supported on USB port 0 and it must be oriented correctly to allow for proper insertion.

Note A sample of how the memory stick is inserted into the port.

Figure 24: USB Memory Stick

Note You can insert or remove the memory stick whether the device is powered on or not.

1	USB Type C (3.0) (USB 1)
2	USB stick
3	USB Type A (3.0) (USB 0)

What to do next

This completes the USB Flash memory installation procedure.

Remove and Install an M.2 USB|NVMe Module

This section describes installing and replacing an M.2 USB|NVMe module on the Cisco Catalyst 8200 Series Edge Platforms.

Prevent Electrostatic Discharge Damage

The M.2 module is sensitive to electrostatic discharge (ESD) damage, which can occur when electronic cards or components are handled improperly. ESD results in complete or intermittent failures.

To prevent ESD damage, follow these guidelines:

- Always use an ESD wrist or ankle strap and ensure that it makes good skin contact.
- Connect the equipment end of the strap to an unfinished chassis surface.
- Place the M.2 storage devices on an anti-static surface or in a static shielding bag. If you have to return the device to the factory, immediately place it in a static shielding bag.
- Avoid contact between the device and clothing. The wrist strap protects the device from ESD voltages on the body only; ESD voltages on clothing can still cause damage.
- Do not remove the wrist strap until the installation is complete.



Caution

For safety, periodically check the resistance value of the anti static strap. The measurement should be between 1 and 10 megohms (Mohms).

Remove the M.2 USB|NVMe Module

To remove a M.2 USB|NVMe module, perform these steps:



Note

The M.2 USB|NVMe modules for Cisco Catalyst 8200 Series Edge Platforms are flipped upside down.

-
- Step 1** The device should be powered down and the power supply disconnected before you perform any module replacement.
- Step 2** Loosen 2 mounting screws using a #1 Philips screwdriver.
- Step 3** Gently pull the M.2 USB|NVMe module out and remove it from the device.

Figure 25: Remove the M.2 USB|NVMe Module (Cisco 8200 Series Chassis)

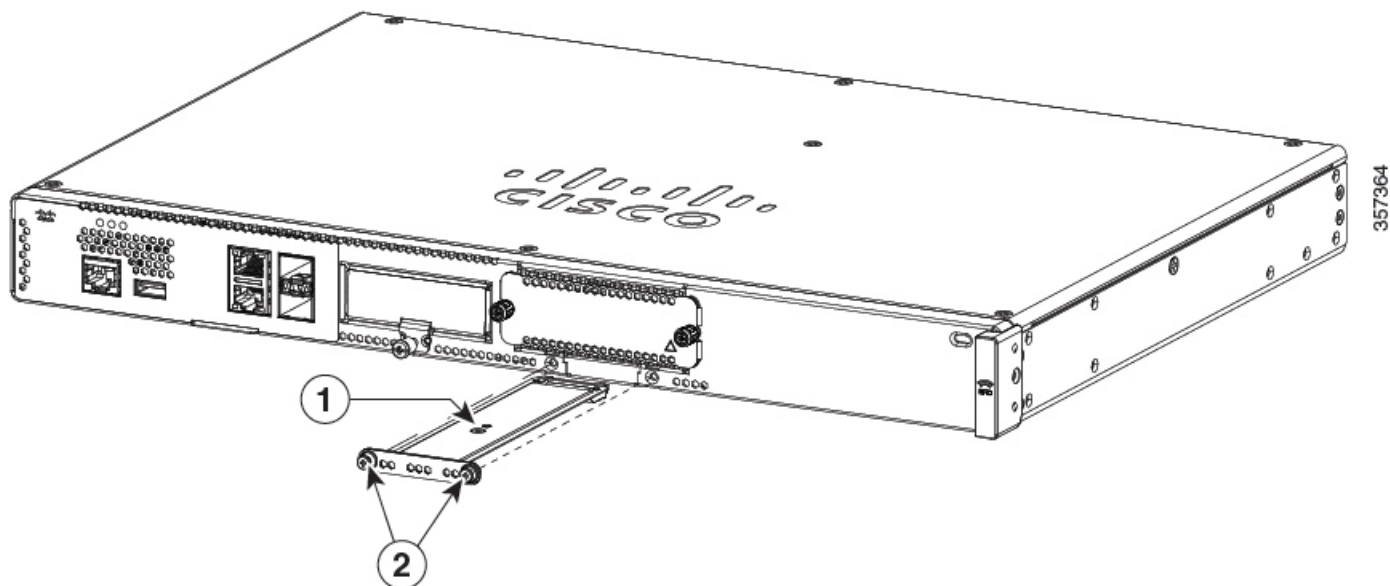

1	M.2 USB NVMe module	2	Securing screws (torque 4-6 in-lbs)
---	---------------------	---	-------------------------------------

Install the M.2 USB|NVMe Module



Note The M.2 USB|NVMe module's orientations are flipped. For the Cisco Catalyst 8200 Series device, the PCB faces down.

To install the M.2 USB|NVMe module, perform the following steps:

- Step 1** Read all Safety Warnings, ensure that the Cisco Catalyst 8200 Series device is not powered on.
- Step 2** Insert the M.2 USB|NVMe module into the slot of the device (as shown in the figure). The slide should engage the internal card guides.
- Step 3** Gently slide the M.2 USB|NVMe module all the way in until the faceplate is flush with the device.
- Step 4** Screw down and tighten the two Philips head screws. Torque it to 4-6 in lbs.
- Step 5** The device can now be powered on.

Figure 26: Install the M.2 USB|NVMe (Cisco 8200 Series Chassis)

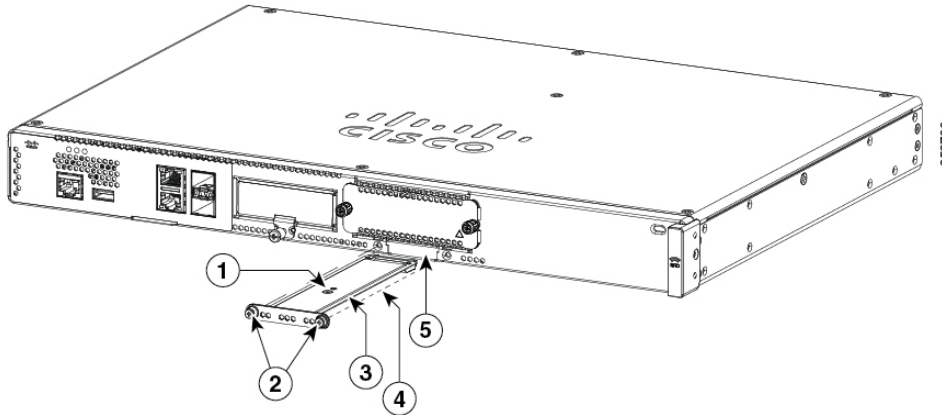

1	M.2 USB NVMe	2	Securing screws (torque 4-6 in-lbs)
3	M.2 module orientation with metal carrier on top, M.2 module underneath.	4	M.2 module underneath
5	Chassis cutout prevents M.2 installation in wrong orientation.		



CHAPTER 5

Install Cisco Catalyst Network Interface Module

This section provides information before and during the installation of Cisco Catalyst Network Interface Modules (NIMs) on the Cisco Catalyst 8200 Series Edge Platforms.

- [Overview of the Network Interface Module, on page 57](#)
- [Remove and Install Network Interface Modules, on page 58](#)

Overview of the Network Interface Module

The Cisco Catalyst Network Interface Module (NIM) is supported on Cisco Catalyst 8200 Series Edge Platforms.

These are the steps to install a NIM:

1. Locate the NIM slot on the front panel.
2. Loosen the screws to remove NIM blank cover.
3. Insert the NIM into the slot.
4. Tighten the screws to secure the NIM in the slot.

These are the steps to remove a NIM:

1. If the NIM is up and running, issue the following command to shut down the NIM gracefully before removing it:

```
hw-module subslot slot 0/2 stop
```



Caution If you do not shut down the NIM gracefully before removing it, the NIM card could get damaged.

2. Locate the NIM slot on the front panel.
3. Loosen the screws that secure the NIM.
4. Gently pull out the NIM from the slot.

All module slots must have a module or blank installed for the product to work thermally and for safety purposes.

For additional information, see the Cisco Catalyst 8200 Series Edge Platforms datasheet on cisco.com for a list of supported NIMs on the platforms.

Remove and Install Network Interface Modules

Keep the following tools and equipment while working with the Network Interface Modules (NIM)s:

- Number 1 Phillips screwdriver or a small flat-blade screwdriver
- ESD-preventive wrist strap

Remove the Network Interface Module

Step 1 Shut down the electrical power to the slot in the device, turn off the electrical power to the device. Leave the power cable plugged-in to channel ESD voltages to ground.

Step 2 Remove all network cables from the rear panel of the device. Using a number 1 Phillips screwdriver, loosen the captive screws on the network interface module.

Step 3 Slide the network interface module out.

Step 4 If you are not replacing the module, install a blank faceplate over the empty slot to ensure proper air flow.

Install the Cisco Catalyst Network Interface Modules

Step 1 Shut down the electrical power to the slot in the router by turning off the electrical power to the router. Leave the power cable plugged in to channel ESD voltages to ground.

Step 2 Remove all network cables from the rear panel of the device.

Step 3 Remove the blank faceplates installed over the network interface module slot that you intend to use.



Note Save blank faceplates for future use.

Step 4 Align the module with the guides in the chassis walls or slot divider and slide it gently into the NIM slot on the device.

Step 5 Push the module into place until you feel the edge connector seat securely into the connector on the router backplane. The module faceplate should contact the chassis rear panel.

Step 6 Using a number 1 Phillips screwdriver, tighten the captive screws on the network interface module.

Step 7 Connect the module to the network and re-enable the power to the slot in the device.



CHAPTER 6

Cisco Catalyst Pluggable Interface Module

This section provides information before and during the installation of Cisco Catalyst Pluggable Interface Module (PIM) on the Cisco Catalyst 8200 Series Edge Platforms.

For additional information on the supported PIMs, see the Cisco Catalyst 8200 Series Edge Platforms' datasheet on cisco.com for a list of supported PIMs on the platforms.

Figure 27: Pluggable Interface Module in a Cisco 8200 Series Chassis

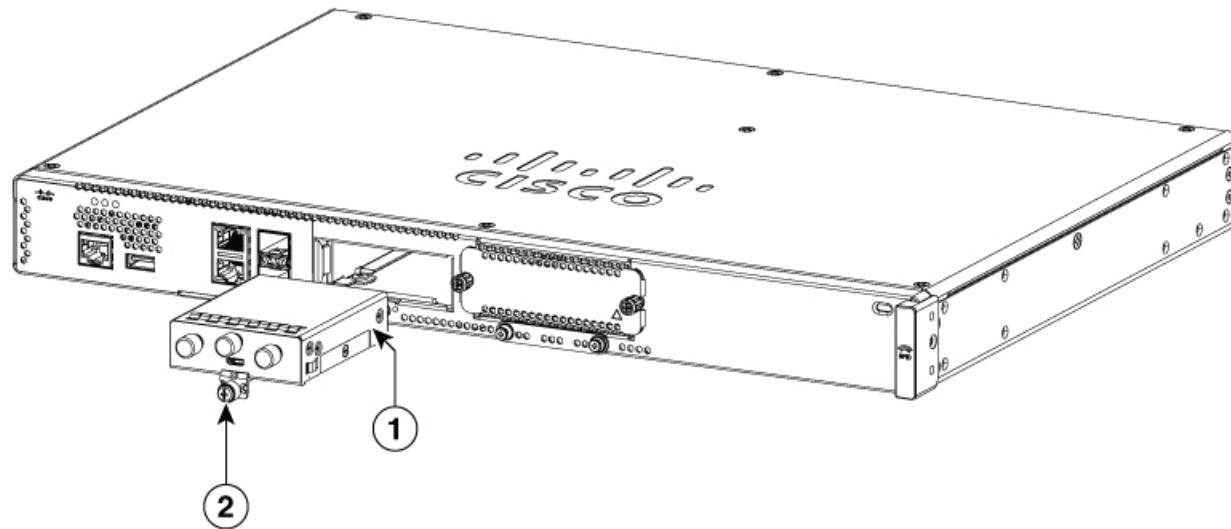

1	Pluggable interface module (PIM)
2	Screw

- [Safety Recommendations](#), on page 60
- [Tools and Equipment Required During Installation](#), on page 60
- [Remove Cisco Catalyst Pluggable Interface Module](#), on page 60
- [Install a Cisco Catalyst Pluggable Interface Module](#), on page 61
- [Configuring a Pluggable Interface Module](#), on page 62
- [RF Band Mapping for Antenna Ports \(For P-5GS6-GL only\)](#), on page 63
- [Attaching the Antennas](#), on page 64

Safety Recommendations

To prevent hazardous conditions, follow these safety recommendations while working with this equipment:

- Keep tools away from walk areas where you or others could fall over them.
- Do not wear loose clothing around the router. Fasten your tie or scarf and roll up your sleeves to prevent clothing from being caught in the chassis.
- Wear safety glasses when working under any conditions that might be hazardous to your eyes.
- Locate the emergency power-off switch in the room before you start working. If an electrical accident occurs, shut the power off.
- Before working on the router, turn off the power and unplug the power cord.
- Disconnect all power sources before doing the following:
 - Installing or removing a router chassis
 - Working near power supplies
- Do not work alone if potentially hazardous conditions exist.
- Always check that power is disconnected from a circuit.
- Remove possible hazards from your work area, such as damp floors, ungrounded power extension cables, or missing safety grounds.
- If an electrical accident occurs, proceed as follows:
 - Use caution; do not become a victim yourself.
 - Turn off power to the room using the emergency power-off switch.
 - Determine the condition of the victim and send another person to get medical aid or call for help.
 - Determine if the person needs rescue breathing or external cardiac compressions; then take appropriate action.

Tools and Equipment Required During Installation

You will need the following tools and equipment while working with the Cisco C-NIM-1X NIM:

- Number 1 Phillips screwdriver or a small flat-blade screwdriver
- ESD-preventive wrist strap

Remove Cisco Catalyst Pluggable Interface Module

To remove a PIM, perform these steps:

- Step 1** Read the Safety Warnings before you perform any task.
- Step 2** Power down the unit and remove power from the power supplies.
- Step 3** Loosen the Phillips head screw on the module faceplate, and then pull out the module by gripping the screw.

Install a Cisco Catalyst Pluggable Interface Module

To install a PIM, perform these steps:

- Step 1** Read the Safety Warnings before you perform any task.
- Step 2** Power down the unit and remove power from the power supplies.
- Step 3** If there is a filler faceplate blank in the PIM slot, loosen the Phillips head screw and remove the blank.
- Step 4** Push the module into the slot until you feel the edge connector seat into the connector on the backplane. The module faceplate should contact the chassis panel.
- Step 5** Tighten the Phillips head screw on the module faceplate.
- Step 6** The device may now be powered on.

Figure 28: 5G Pluggable Interface Module - P-5GS6-GL

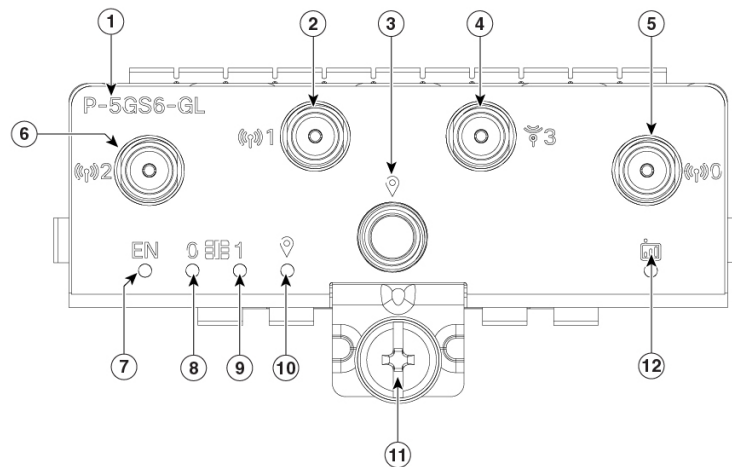

1	PID
2	Antenna 1 (SMA)
3	GPS (SMA)
4	Antenna 3 (SMA, reception only)
5	Antenna 0 (SMA)

6	Antenna 2 (SMA)
7	Enable LED
8	SIM 0 LED
9	SIM 1 LED
0	GPS LED
1	M3.5 thumb-screw
2	Service LED

Configuring a Pluggable Interface Module

To insert the antenna in the Pluggable Interface Module, perform the below steps:

Figure 29: Attaching the Antennas

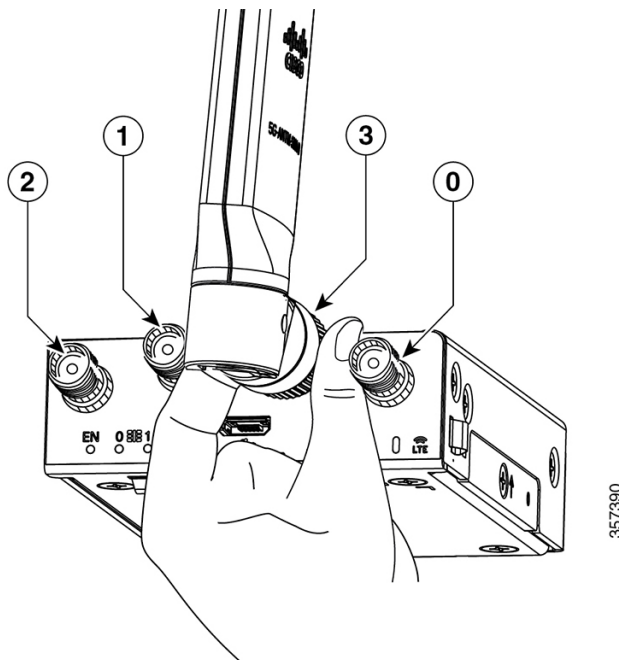

Step 1 Use your thumb and index finger to insert and tighten antenna 1 and antenna 3 in the middle antenna attachment slots as indicated in the figure.

Note While installing the antennas, first install antenna 1 and antenna 3 (this instruction is for the two antenna attachments present in the middle) and secure it completely. If you install antenna 2 and antenna 0 first (this refers to the first and the last antenna attachments), there will be less space to insert your thumb and index finger and therefore you may not be able to secure antenna 1 and 3.

Step 2 Insert antenna 2 and antenna 0 in the first and last antenna attachment slots.

- Step 3** After installing the antennas, adjust the antenna orientation by spacing out each of them equally until they are spread out. This is important as it helps in getting higher RF performance.
-

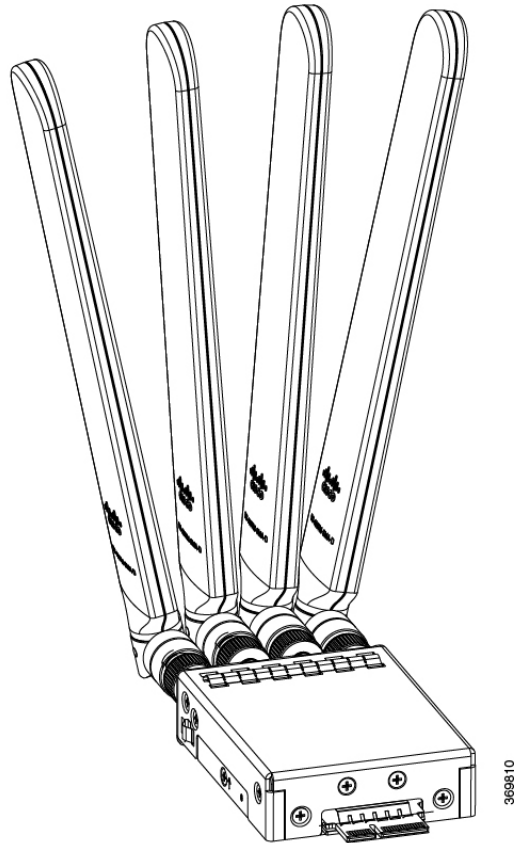

RF Band Mapping for Antenna Ports (For P-5GS6-GL only)

The following table lists the RF band mapping for antenna ports.

RF Band Mapping for Antenna Ports:

Antenna Port	Technology	TX	RX
ANT 0	3G WDCMA	B1, B2, B3, B4, B5, B6, B8, B9, B19	B1, B2, B3, B4, B5, B6, B8, B9, B19
	LTE	B1, B2, B3, B4, B5, B7, B8, B12, B13, B14, B17, B18, B19, B20, B25, B26, B28, B30, B34, B38, B39, B40, B41, B66, B71	B1, B2, B3, B4, B5, B7, B8, B12, B13, B14, B17, B18, B19, B20, B25, B26, B28, B29, B30, B32, B34, B38, B39, B40, B41, B42, B43, B46, B48, B66, B71
	5G NR FR1	n1, n2, n3, n5, n7, n8, n12, n20, n28, n38, n40, n41, n66, n71	n1, n2, n3, n5, n7, n8, n12, n20, n25, n28, n38, n40, n41, n48, n66, n71, n77, n78, n79
ANT 1	3G WDCMA	-	B1, B2, B3, B4, B5, B6, B8, B9, B19
	LTE	B5, B20, B42, B43, B48, B71	B1, B2, B3, B4, B5, B7, B8, B12, B13, B14, B17, B18, B19, B20, B25, B26, B28, B29, B30, B32, B34, B38, B39, B40, B41, B42, B43, B46, B48, B66, B71
	5G NR FR1	n5, n48, n77, n78, n79	n1, n2, n3, n5, n7, n8, n12, n20, n25, n28, n38, n40, n41, n48, n66, n71, n77, n78, n79
ANT 2	3G WDCMA	-	-
	LTE	B1, B2, B3, B4, B7, B41, B66	B1, B2, B3, B4, B7, B25, B30, B32, B34, B38, B39, B40, B41, B42, B43, B46, B48, B66
	5G NR FR1	n1, n2, n3, n7, n25, n41, n66, n77, n78, n79	n1, n2, n3, n7, n25, n38, n40, n41, n48, n66, n77, n78, n79
ANT 3	3G WDCMA	-	-
	LTE	-	B1, B2, B3, B4, B7, B25, B30, B32, B34, B38, B39, B40, B41, B42, B43, B46, B48, B66
	5G NR FR1	-	n1, n2, n3, n7, n25, n38, n40, n41, n48, n66, n77, n78, n79

Attaching the Antennas

To attach the antenna in the Pluggable Interface Module, perform the below steps:

Figure 30: Attaching 5G NR Antenna (5G-ANTM-04-B) to P-5GS6-GL PIM

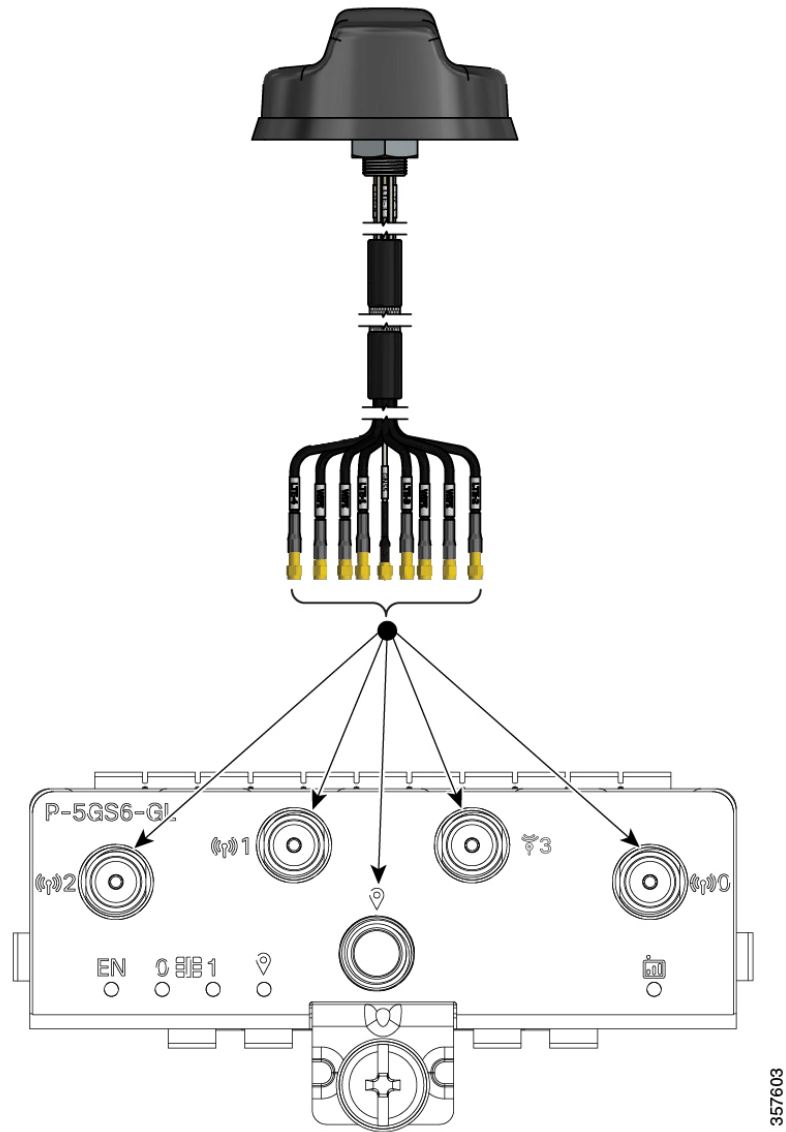

Note 5G NR Antenna (5G-ANTM-04-B) is supported on both P-LTEAP18-GL and P-5GS6-GL PIMs.

1. Attach each SMA cable to the ports as indicated in the table mappings.
2. Ensure that you tighten and secure each SMA cable into the SMA connector on the PIM.

Table 7: Port Mappings for 5G-ANTM-0-4-B on P-5GS6-GL and P-LTEAP18-GL PIMs

5G-ANTM-0-4-B	P-LTEAP18-GL	P-5GS6-GL
MAIN 0 (LTE1)	Main 0	ANT 0
MAIN 1 (LTE3)	Main 1	ANT 1
DIV 0 (LTE2)	DIV 0	ANT 2
DIV 1 (LTE4)	DIV 1	ANT 3
GNSS	No connection	GPS

The following link contains the antenna specifications and installation instructions for 5G NR (5G-ANTM-O-4-B):

https://www.cisco.com/c/en/us/td/docs/routers/connectedgrid/antennas/installing-combined/b-cisco-industrial-routers-and-industrial-wireless-access-points-antenna-guide/m-5g-antm-04b.html#Cisco_Generic_Topic.dita_e780a6fe-fa46-4a00-bd9d-1c6a98b7bcb9



CHAPTER 7

Online Insertion and Removal and Hot-Swapping

The online insertion and removal (OIR) operation lets you replace faulty data and voice modules without affecting system operations. The OIR is similar to hot-swapping. OIR commands are issued before removing and after installing a module. When performing OIR, use an identical module to replace an original one. If you need to perform the OIR operation on multiple modules within a router, perform the operation one module at a time.

The difference between hot-swapping and OIR is that OIR requires executing Cisco IOS commands before and after the OIR. Hot-swapping is strictly a hardware function and does not require the execution commands. Not all router components or modules use OIR, or can be hot swapped.

The following components use OIR in the routers:

- Network Interface Modules (NIMs)
- SFPs
- USB devices



Note The M.2 USB/NVMe module cannot be hot-swapped. The router must be powered off if the M.2 USB/NVMe module is to be removed or installed.

Requirement

To issue OIR commands, you must keep the module that is to be replaced in EnergyWise full-power mode. If the module is in EnergyWise power-saving or shutdown mode, you cannot issue OIR commands, and you cannot, therefore, remove the module.

- [OIR Procedures, on page 67](#)

OIR Procedures

The following procedures describe using the OIR process to remove and replace NIMs and SMs.

Remove a Module

From a console terminal run the **hw-module subslot subslot stop** command. The service module adapter LED blinks, turns off, and the console displays a prompt signaling the module can be removed. See the following output:

```
Device# hw-module subslot 2/0 stop
Proceed with stop of module? [confirm]
damo-O2#
*Mar 22 20:43:31.088: %SPA_OIR-6-OFFLINECARD: SPA (SM-X-1T3/E3) offline in subslot 2/0
*Mar 22 20:43:31.088: %IOSXE_OIR-6-SOFT_STOPSPA: SPA(SM-X-1T3/E3) stopped in subslot 2/0,
interfaces disabled
Device# show hw-module subslot 2/0 oir
Module Model Operational Status
-----
subslot 2/0 SM-X-1T3/E3 stopped
```

Insert a Module

You require to run this step only if you run the oir-stop command when the module is not physically removed from the slot. If the module is physically removed, you do not require to run this command.

From a console terminal issue the **hw-module sm {slot} oir-start** command. The console displays output that shows the module change states:

```
Device# hw-module sm 2 oir-start
Device#
*Nov 11 21:06:17.546: %ATMOC3POM-6-SFP_IN: Interface ATM2/0 OC3 MM SFP has been inserted.
Router#
*Nov 11 21:06:19.442: %LINK-3-UPDOWN: Interface ATM2/0, changed state to up
*Nov 11 21:06:20.442: %LINEPROTO-5-UPDOWN: Line protocol on Interface ATM2/0, changed state
to up
```