

ENS Group **MM-10-302** Instructions

PARTS INCLUDED

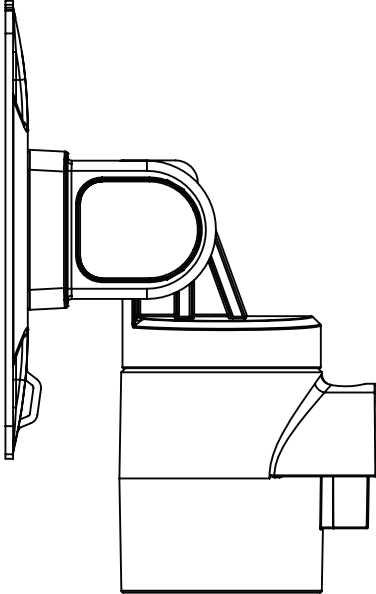

Double Pivot Monitor Mount

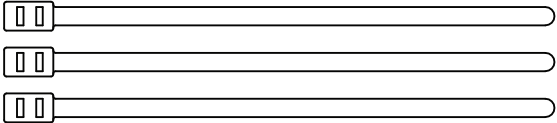

3x 6.0" Cable Ties

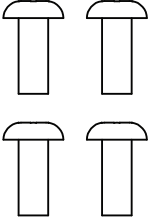

4x M4 x 10mm
Phillips Screws

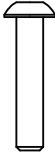

M4 x 20mm
Socket Head Screw



2.5 mm Hex Wrench

ENS Group **MM-10-302**
DOUBLE PIVOT MONITOR MOUNT INSTALLATION

Tools Required:
2.5mm Hex Wrench (Provided)
#2 Phillips Screwdriver

Step 1: Attach the Double Pivot Monitor Mount to the Channel Arm or Mount using the M4 x 20mm Socket Head Screw as shown

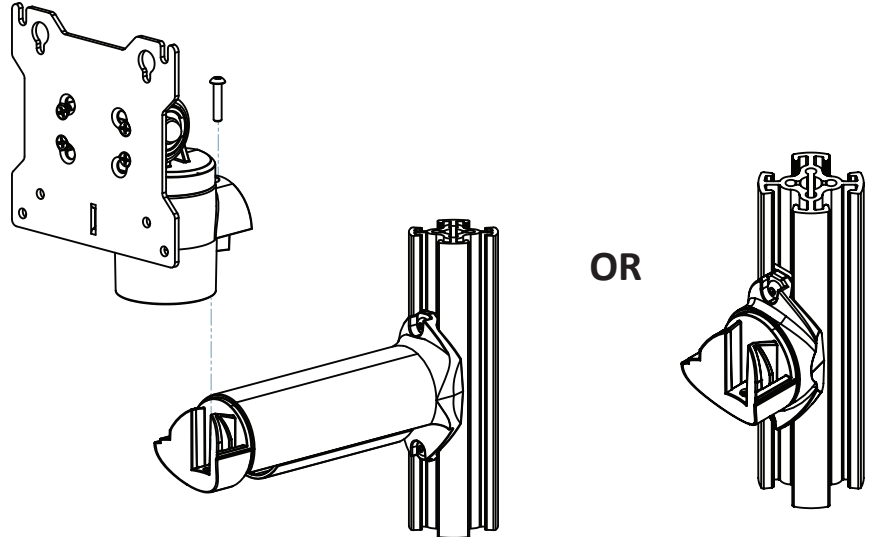

Step 2: Attach your VESA Monitor to the Double Pivot Mount using the 4x M4 x 10mm Phillip Screws as shown

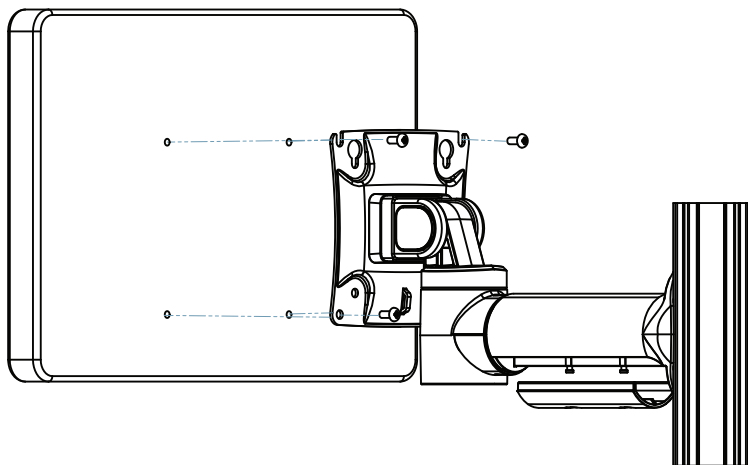

Step 3: Route and strain relief you Cables using 6" Cable Ties

