



RAND
MCNALLY

ClearDryve[®] 180

Quick Start Guide



Contents

What's in the box	2
ClearDryve® Parts.....	3
Function Button Layout.....	4
Getting Started with ClearDryve®	6
Charge the Battery	6
Power ClearDryve® On and Off	7
Pair With a Device over Bluetooth®	7
Call Mode	9
Quick Access	9
Answer an Incoming Call	10
End a Call.....	10
Ignore an Incoming Call.....	10
Redial the Last Number.....	11
Mute/Unmute a Call	11
Turn the Volume Up and Down	12

Streaming Music	13
Quick Access	13
Play and Pause.....	13
Turn the Volume Up and Down	14
Go to the Next/Previous Song	14
Connect to a Wired Device	15
More Functions	16
Active Noise Cancellation.....	16
EQ Preset.....	17
Add/Remove the Stereo Earpiece	18
Reset to Factory Settings.....	19
Troubleshooting & FAQ	20
Help and Support	21
Warnings, End-User License Agreement, and Warranty	22

What's in the Box

In-box contents includes:

- ClearDryve® 180 headphones
- Audio cable
- Charging cable
- Hard-sided carrying case
- Detachable earpiece (comes pre-assembled to the headphones)
- Detachable headpad

ClearDryve® Parts

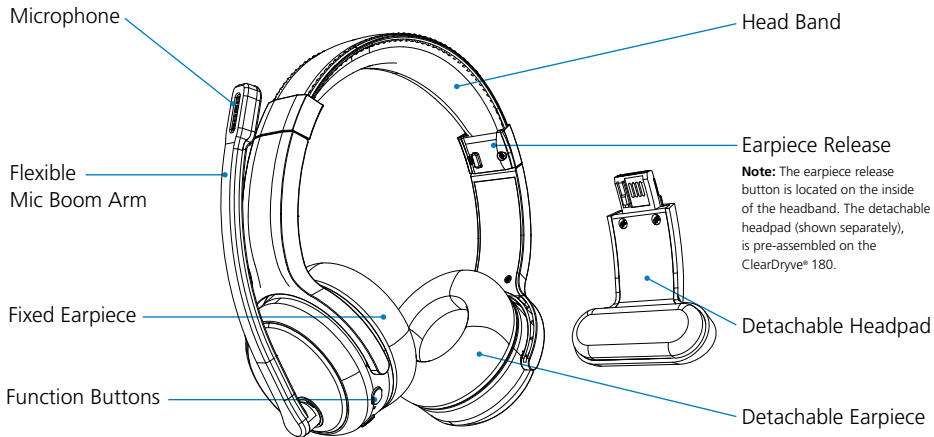

Dimensions: approx. 7.5" x 7.3" x 3.3"

Function Button Layout

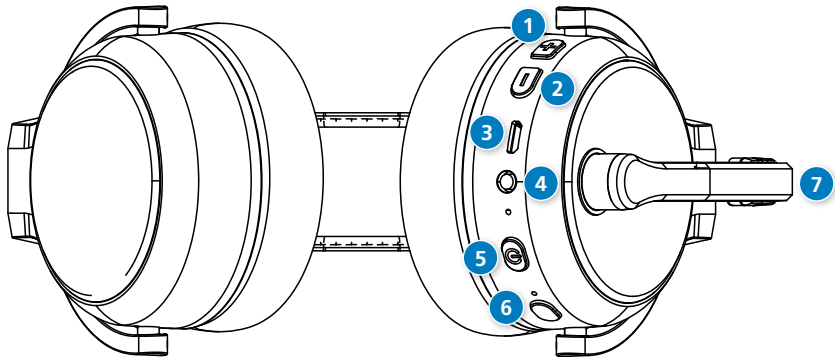

The mic boom arm, ports, LEDs, and function buttons on the ClearDryve® headphones are on the same earpiece. You can use this earpiece on either ear. ClearDryve® automatically adjusts for either side when you extend the mic arm. To switch the earpiece with controls from one ear to the other, swivel the mic boom up and over to the other side.

1. **Vol +** button
2. **Vol –** button
3. Micro-USB port
4. 3.5mm audio input
5. **Multi-function button (MFB)**
6. **ANC** button
7. Mic boom arm

You can press, long-press, and hold the buttons on ClearDryve®. Each does a different function:

1. **Press:** Press the button firmly and release it immediately.
2. **Long-press:** Press the button firmly, and keep it depressed for about a second.
3. **Hold:** Press and hold the button down for the amount of time listed.

Getting Started with ClearDryve®

To get started using ClearDryve®, first you need to charge the battery. After you power it on, then you can pair ClearDryve® to your Bluetooth® - enabled phone, tablet or laptop. Once ClearDryve® is paired, you can immediately start taking and managing calls or listening to music.

Charge the Battery

- ✓ Before use, you need to charge the battery on ClearDryve®.
- ✓ Connect the USB cable to the micro-USB port on ClearDryve®. Connect the other end to a charger.
- ✓ When you turn on ClearDryve® on, it announces the battery level as a percentage of its capacity.
- ✓ If the battery level is low when you power on ClearDryve®, you will hear an intermittent “beep” up-to 5 times, as a reminder to charge it.

Power ClearDryve® On and Off

To turn ClearDryve® on and off:

1. To power ClearDryve® on, press the **MFB**.
2. You will hear "Power on."
3. To power ClearDryve® off, press and hold the **MFB**.
4. You will hear "Power off."

When you power ClearDryve® on for the first time, it automatically enters pairing mode. The next time you turn it on, it will automatically attempt to connect with the most recently-paired device.

Pair with a Device over Bluetooth®

When you power ClearDryve® on for the first time, it automatically enters pairing mode. In pairing mode, the LED indicator blinks blue and red, and you will hear "Pairing."

Once a device is paired, the LED stays solid blue. ClearDryve® will reconnect automatically when Bluetooth® is enabled and the device is within range.

To pair ClearDryve® with a BT device:

1. **Power** on ClearDryve®.
2. Enable **Bluetooth**® on your device.
3. ClearDryve® will display on your device as ClearDryve®. **Select it.**
4. The **LED** will change to solid blue.

You can pair ClearDryve® to a new device at any time by entering pairing mode again.

To enter pairing mode again:

1. If the headphones is on, turn it off by pressing and holding the **MFB**.
2. Press and hold the **MFB**.
2. The **LED** indicator blinks blue and red, and you will hear **"Pairing."**

As soon as it is paired with a device, ClearDryve® is ready to make calls or stream music.

Note: When ClearDryve® is turned on and not in pairing mode, it will automatically pair with the most recently paired device when it is on.

Call Mode

In Call Mode, you can answer incoming calls, and use your smartphone's voice assistant to make hands-free calls.

Quick Access

Answer a call	Press the MFB .
End a call	Press the MFB .
Ignore a call	Press and hold the MFB . <i>Note: The duration of the press should more than 1 second but less than 3 seconds. Holding down the MFB for too long (i.e., over 3 seconds) will cause ClearDryve® to power down.</i>
Redial	Double-press the MFB
Mute/Unmute	Rotate the mic arm up (to mute) or down (to unmute)
Adjust volume	Press Vol + or Vol -

Answer an Incoming Call

To answer an incoming call:

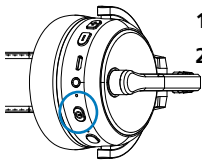

1. Press the **MFB**.
2. ClearDryve® **will beep once** to confirm.
The call will be live immediately.



Note: Make sure the mic boom arm is down.

End a Call

To end a call:

1. Press the **MFB** to hang up.
2. ClearDryve® **will beep once** to confirm.

Ignore an Incoming Call

To ignore an incoming call:

1. Press and hold the **MFB** for about 3 seconds.
2. ClearDryve® **will beep once** to confirm.

Note: Holding down the MFB for too long (i.e., over 5 seconds) will cause ClearDryve® to power down.

Redial the Last Number

To redial the last connected number:

1. Quickly press the **MFB** twice.
2. ClearDryve® will beep once to confirm.

Mute/Unmute a Call

The moveable mic arm provides an easy way to mute or unmute the mic when you are on a call.

To mute the call:

1. **Move the mic arm up** and away from your mouth, to about 30 degrees or more above horizontal.

To unmute the call:

1. **Move the mic arm back down** in front of your mouth.

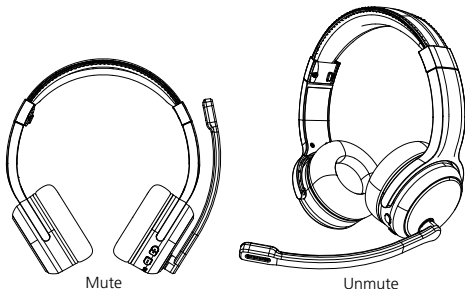

Note: You can use ClearDryve® with the mic arm on either ear. These steps work the same on both sides. To switch sides, rotate the mic arm all the way around.

Turn the Volume Up and Down

At any time, you can press the volume buttons to turn the volume of the call up or down. There are 16 different volume levels available.

To change the volume:

1. Press **Vol +** to increase the volume.
2. Press **Vol -** to decrease the volume.
3. ClearDryve® will **beep** when you reach the lowest or highest volume settings.

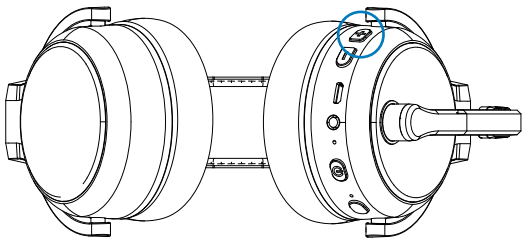

Note: Depending on your device, the volume buttons may behave differently. On some devices the ClearDryve® volume buttons may control the device volume instead of ClearDryve® volume.

Streaming Music

Quick Access

Play/Pause	Press the MFB
Adjust volume	Press Vol + or Vol -
Next/Previous	Long-press Vol + or Vol -

Play and Pause

To play or pause music:

1. Press the **MFB** while in Music Mode.

Note: ClearDryve® does not have a "Stop" function.

Turn the Volume Up and Down

At any time, you can press the volume buttons to turn the volume of ClearDryve® up or down.

There are 16 different volume settings available.

To change the volume:

1. Press **Vol +** to increase the volume.
2. Press **Vol –** to decrease the volume.
3. ClearDryve® will **beep** when you reach the lowest or the highest volume.

Go to the Next/Previous Song

To switch to a different song:

1. Long-press **Vol +** to advance to the next song.
2. Long-press **Vol –** to go back to the beginning of the current song. Long-press again to go to the previous song.

Note: Depending on your device, the volume buttons may behave differently. On some devices the ClearDryve® volume buttons control the device volume instead of ClearDryve® volume.

Connect to a Wired Device

You can connect ClearDryve® to any standard 3.5mm audio aux jack.

- 1. Connect** the included 3.5mm audio cable to the audio in jack on ClearDryve®.
- 2. Connect** the cable to the aux out on your music device.

Note: You must use the included aux cable to connect your device to ClearDryve®. When using ClearDryve® in wired mode, Bluetooth® functions including volume control on the headphones will not work.

More Functions

Active Noise Cancellation

The ClearDryve® signal processing removes more than 90% of noise reaching the microphone so those on the other end of the call hear you — not the background. This digital noise suppression is always active. In addition, your ClearDryve® features Active Noise Cancellation (**ANC**), which eliminates the need to “crank up the volume” by canceling out ambient noise reaching **your** ear. The result is a crystal-clear listening experience for you as well.

To turn ANC on or off:

1. Push the **ANC button** to turn it on or off.
2. When **ANC** is enabled, a blue light indicator next to the button will turn on.
3. When **ANC** is disabled, a blue light indicator next to the button will turn off.

Note: **ANC** can be turned on for use in either Bluetooth® (wireless) or wired mode. When the headphone is not in use, remember to turn off **ANC** to conserve battery power.

EQ preset

Your ClearDryve allows you to pick from 5 preset equalizer (EQ) settings. This allows you to pick the ideal settings for the specific type of music you are listening to. EQ preset selections are only available when ANC is turned off.*

When you first turn on power to your ClearDryve, the first equalizer setting (EQ1) is active by default. You can select a different EQ setting during music playback.**

- As you listen to music on ClearDryve, press and hold the **MFB**
- Quickly (within 2 seconds) tap on the **Vol +** button.
- Each tap on the **Vol +** button causes the next EQ setting to become active.
- Once you've found the best EQ setting, release the **MFB**.

* **Note:** When ANC is turned on, the headphone defaults to the first equalizer setting (EQ1). You can only select one of the other preset equalizer settings if you turn ANC off.

** **Note:** EQ preset functionality is only applicable during music playback. It is not applicable and does not impact voice quality during hands-free phone calls.

Add/Remove the Detachable Stereo Earpiece

ClearDryve® can convert from mono (one earpiece plus headpad) to stereo (two earpieces). The detachable earpiece can be replaced with the headpad for mono configuration.

To remove the earpiece or the headpad:

1. **Hold** the black earpiece release tab.
2. **Slide** the earpiece off.

To attach the earpiece or the headpad:

3. **Slide** the earpiece/headpad onto the ClearDryve® head band.
4. The earpiece will **click** when connected.

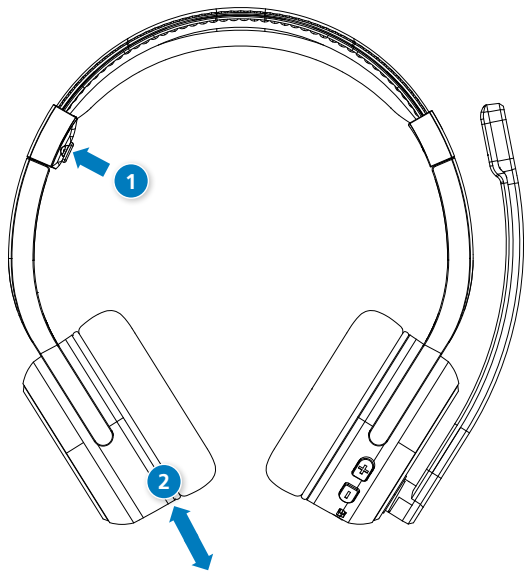

Reset to Factory Settings

You may need to restore ClearDryve® back to its factory state, typically when switching over to newer model smartphones / laptops for daily use. Clearing the “pairing history” on your headphones can help improve connection times between your headphones and new devices.

To reset ClearDryve®:

1. Make sure ClearDryve® is **powered** off. Now press and hold **MFB** to place it in **pairing mode**.
2. Press and hold **Vol -** and **MFB** at the same time until you hear **2 beeps**.

Your ClearDryve's pairing history is now cleared and it is in pairing mode. You can turn off the headphones or proceed to pair it with your device(s).

Note: *The next time you turn on the device, it will automatically be in pairing mode.*

Troubleshooting & FAQ

Issue:	Possible Causes:
My headphones need to be charged very frequently.	ANC may be turned ON , even when you are not using the headphones. Be sure to turn off ANC when the product is not in use, to maximize how long your headphone can be used between charges.
Can I connect more than one device to my headphones.	Yes, your headphones can be simultaneously connected to more than one device. To add new connections after connecting to the first device, turn off the headphones, then press and hold the MFB . The headphones will enter pairing mode. Follow the steps for your unique device (smartphone, laptop, tablet) to connect to the headphones.
I am confident batteries are fully charged, yet they do not seem to work.	In the rare event that your headphones “locks up,” it can be “rebooted” by simply plugging in a micro-USB cable into the charging port of your ClearDryve. The other end of the cable should be plugged into to a USB power source. ClearDryve will turn off and start charging. Let it charge for around 15 minutes, unplug and turn it on to resume operation.

Troubleshooting & FAQ

Issue:	Possible Causes:
I am unable to change my equalizer settings for my headphones.	Selection from 5 EQ (preset equalizer) settings is only available with ANC turned off. When ANC is on, the headphones operate with EQ1 active. To select a different EQ value, turn ANC off, then follow the instructions listed in the section entitled "EQ presets".

Help and Support

Contact Rand McNally customer support for assistance:

- By phone: **1-877-446-4863**
- By email: tndsupport@randmcnally.com
- On the web: <http://www.randmcnally.com/support/category/cleardryve>

Warnings, End-User License Agreement, and Warranty

WARNING: Safe Driving Practices

Never attend to or handle the headphones while driving. Always use your best judgment and exercise common sense when the vehicle is in motion and do not allow yourself to be distracted by the headphones while driving. Pull over in a safe and legal manner before attempting to attend to or handle the headphones.

End-User License Agreement

Rand McNally hereby grants you (“User”) a single-user non-exclusive, non-transferable license to use the software and associated data incorporated in the headphones and related documentation (collectively referred to herein as the “Software Materials”) for User’s own business or personal use and not for resale, sublicense or commercial use. The Software Materials are furnished under license and may be used only in accordance with this license. Except as permitted by such license, the Software Materials may not be disclosed to any third party, copied or duplicated in any form, in whole or in part, without the prior written permission of Rand McNally. The Software Materials contain proprietary and confidential information of Rand McNally and its licensors. Rand McNally grants User a limited license for use of this product and the Software Materials for its normal operation. By using the Software Materials, User acknowledges that such Software Materials are the property of Rand McNally and its licensors and are protected by U.S. copyright, trademark and patent laws and international treaties.

THE USER MAY NOT:

- Use the Software Materials on a network or file server, for time-sharing or to process data for third parties.
- Copy, loan or otherwise transfer or sublicense the Software Materials or any of its content.
- Modify, adapt, decompile, disassemble, reverse engineer or reduce to human readable form the Software Materials for any purpose whatsoever.
- Alter, remove or obscure any copyright notice, trademark notice, or proprietary legend from the product, the Software Materials or its content.

This license will terminate automatically if User fails to comply with any of the terms of this license and, in such case, User agrees to immediately stop using the Software Materials. Rand McNally may revise or update the product or Software Materials, but is not obligated to furnish any revisions or updates to User.

Warranty

Rand McNally warrants that the product and the component parts thereof, will be free of defects in workmanship and materials for a period of one (1) year from the date of purchase. This warranty may be enforced by the first consumer purchaser ("Customer") only, provided that the product is utilized within the U.S.A. or Canada. During the warranty period, Rand McNally will, without charge, repair or replace (with a new or newly reconditioned unit), at its option, a defective product or component part. For repair or replacement of a defective product, Customer must contact Rand McNally at 877-446-4863 for return authorization and instructions. Customer will be required to provide proof of date of first Customer purchase, such as a duplicate copy of the original sales receipt, for the warranty to be valid. The Customer must pay any initial shipping charges required to ship the product for warranty service, but if the product is under warranty, the return charges will be at Rand McNally's expense. Repairs or replacements have a 90-day warranty. If the product is still under its original warranty, then the new warranty is 90 days or to the end of the original one (1) year warranty, whichever is longer. This warranty gives the Customer specific rights. Other rights may be available to Customer, which vary from state to state.

Exclusions: This limited warranty does not apply: 1) to any product damaged by accident; 2) in the event of misuse or abuse of the product or as a result of unauthorized alterations or repairs; 3) if the serial number has been altered, defaced or removed; or 4) if the owner of the product resides outside of the U.S.A. or Canada.

RAND MCNALLY AND ITS LICENSORS DO NOT MAKE ANY OTHER WARRANTY OR REPRESENTATION, EITHER EXPRESS OR IMPLIED, WITH RESPECT TO THE PRODUCT, INCLUDING ANY WARRANTY AS TO MERCHANTABILITY, FITNESS FOR A PARTICULAR PURPOSE, QUALITY, PERFORMANCE, TITLE OR NON- INFRINGEMENT. IN NO EVENT WILL RAND MCNALLY OR ITS LICENSORS BE LIABLE FOR ANY INDIRECT, SPECIAL, INCIDENTAL, OR CONSEQUENTIAL DAMAGES ARISING OUT OF THE USE OF OR INABILITY TO USE THE PRODUCT, EVEN IF ADVISED OF THE POSSIBILITY OF SUCH DAMAGES. Some states do not allow limitations on how long an implied warranty lasts and/or do not allow the exclusion or limitation of incidental or consequential damages, so the above limitations may not apply to some consumers.

©2019 Rand McNally. All rights reserved. Rand McNally, the Rand McNally globe logo and ClearDryve are trademarks of RM Acquisition, LLC, d/b/a Rand McNally.

Support

www.randmcnally.com/support

800-333-0136

