

# In-ceiling Housing

SHD-1408FPW



## Package



HOUSING



CAMERA MOUNT BRACKET

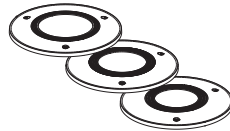

CASE TOP (3EA)

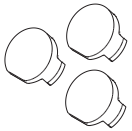

SCREW CAP (3EA)



SAFETY WIRE (1SET)

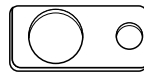

SAFETY BRACKET (1EA)



INSTALLATION MANUAL



MACHINE SCREW (6EA)

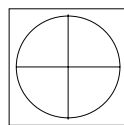

TEMPLATE

## Product Features

**ENG** This In-Ceiling Housing is a mounting adaptor that is designed to mount the smart dome camera in built-in style on a double-layer ceiling. (For compatible models, please visit our website.)

**FRA** Ce boîtier encastré au plafond est un adaptateur de montage conçu pour monter la caméra intelligente à dôme en style encastré sur un plafond à double couche. (Pour les modèles compatibles, veuillez consulter notre site Web.)

**GER** Dieses Deckeneinbaugeschäule ist ein Montageadapter, der zur Montage Smart-Kuppel-Kamera im Einbau in eine angehängte Decke gedacht ist. (Für kompatible Modelle, siehe unsere Webseite.)

**SPA** Esta Carcasa de techo es un adaptador de montaje que ha sido diseñado para montar la cámara de domo inteligente en estilo incorporado en un techo de doble capa. (Para modelos compatibles, visite nuestra página web.)

**ITA** Questo alloggiamento a soffitto è un adattatore di montaggio progettato per montare la telecamera smart a cupola a incasso su un controsoffitto a doppio strato. (Per i modelli compatibili, visitare il nostro sito web.)

**RUS** Этот встраиваемый в потолок корпус представляет собой адаптер для установки встраиваемой интеллектуальной купольной камеры на двухслойный потолок. (Список совместимых моделей см. на веб-сайте Hanwha.)

**POL** Ta Sufitowa Obudowa jest montażowym adapterem przeznaczonym do instalacji kamery z kopułą smart w wbudowanym stylu na dwuwarstwowym suficie. (Informacje dot. kompatybilnych modeli znaleźć można na naszej stronie internetowej.)

**TUR** Bu Tavan Muhafazası, akıllı dom kamerayı çift katmanlı tavanda entegre stilde monte etmek için tasarlanmış bir montaj adaptörüdür. (Uyumlu modeller için, lütfen web sayfamızı ziyaret edin.)

**SWE** Detta innetakshölje är en monteringsadapter som har utformats för inbyggd montering av smart kupolkamera på innetak med dubbelt lager. (Gå till vår webbplats för att se kompatibla modeller.)

**POR** Este suporte de teto é um adaptador de montagem desenvolvido para a instalação da câmera com domo inteligente em estilo embudido em teto de forro duplo. (Para ver os modelos compatíveis, acesse o nosso site.)

**JAP** In-ceiling Housingはスマートドームカメラをデュアル天井に埋立型でインストールする場合に使用するアダプターです。 (互換できる型名は当社のウェブサイトを確認してください。)

**CHI** In-ceiling Housing是在双天花板上安装智能半球摄像机时使用的适配器。(有关兼容型号, 请参阅我们的网页。)

**KOR** In-ceiling Housing은 스마트돔 카메라를 이중 천장에 매립형으로 설치할 경우 사용되는 어댑터입니다. (호환 가능 모델은 당사 웹페이지를 참고 바랍니다.)

## Installation Precautions

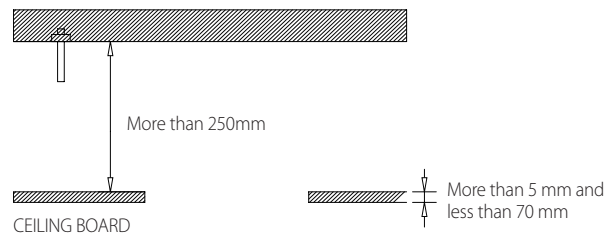

**ENG**

- Select an installation position or place that can endure more than 4 times of the total weight of the installation structure.
- At least 250mm or more of spare height is required above the CEILING BOARD.
- Be sure to secure the SAFETY WIRE to avoid a product fall.
- Use the provided screws to install the mount bracket and camera.
- CEILING BOARD must be able to sustain the weight of at least 10 kg.

**FRA**

- Choisissez une position ou un endroit d'installation qui peut supporter plus de 4 fois le poids total de la structure d'installation.
- Il convient de laisser en espace libre d'au moins 250 mm au-dessus du PANNEAU PLAFOND.
- Veillez à protéger le FIL DE SÉCURITÉ pour éviter la chute d'un produit.
- Utilisez les vis fournies pour installer le support de montage et la caméra.
- Le PANNEAU PLAFOND doit être capable de supporter un poids d'au moins 10 kg.

**GER**

- Eine Installationsposition oder einen Installationsort auswählen, der mehr als das Vierfache des Gesamtgewichts der Installationsstruktur aushalten kann.
- Mindestens 250 mm oder mehr freie Höhe ist erforderlich über der DECKENPLATTE.
- Sicherstellen, dass das SICHERHEITSKABEL befestigt ist, um ein Herunterfallen des Produkts zu verhindern.
- Mit den mitgelieferten Schrauben die Montagehalterung und die Kamera installieren.
- Die DECKENPLATTE muss ein Gewicht von mindestens 10 kg tragen können.

**SPA**

- Seleccione una posición o lugar de instalación que pueda soportar 4 veces más el peso total de la estructura de la instalación.
- Se requiere al menos 250 mm o más de espacio libre sobre el TABLERO DEL TECHO.
- No olvide asegurar el CABLE DE SEGURIDAD para evitar la caída del producto.
- Use los tornillos suministrados para instalar el soporte de montaje y la cámara.
- El TABLERO DEL TECHO debe ser capaz de soportar un peso de al menos 10 kg.

**ITA**

- Selezionare una posizione per il montaggio o un posto che possa sopportare più di 4 volte il peso totale della struttura di installazione.
- Sono necessari almeno 250 mm o più di spazio libero al di sopra del PANNELLO DEL SOFFITTO.
- Assicurarsi di fissare il FILO DI SICUREZZA per evitare la caduta del prodotto.
- Utilizzare le viti in dotazione per installare la staffa di montaggio e la telecamera.
- Il PANNELLO DEL SOFFITTO deve essere in grado di sostenere un peso di almeno 10 kg.

**RUS**

- Выберите место для установки или поверхность, которая может выдержать вес, превышающий четырехкратный общий вес конструкции для установки.
- Над ПОТОЛОЧНОЙ ПАНЕЛЬЮ должно присутствовать свободное пространство высотой не менее 250 мм.
- Во избежание падения устройства обязательно закрепите СТРАХОВОЧНЫЙ ТРОС.
- Для крепления монтажного кронштейна и камеры используйте входящие в комплект винты.
- ПОТОЛОЧНАЯ ПАНЕЛЬ должна выдерживать вес не менее 10 кг.

**POL**

- Wybierz pozycję montażu lub miejsce, które wytrzyma ponad 4-krotność całkowitego ciężaru konstrukcji montażowej.
- Wymagane jest co najmniej 250 mm wolnej przestrzeni nad PŁYTA SUFITOWĄ.
- Należy zabezpieczyć PRZEWÓD BEZPIECZENSTWA, aby uniknąć upadku produktu.
- Użyj dostarczonych śrub, aby zainstalować wspornik montażowy i kamerę.
- PŁYTA SUFITOWA musi wytrzymać ciężar co najmniej 10 kg.

**TUR**

- Kurulum yapısının toplam ağırlığının 4 katından fazlasına dayanabilecek bir kurulum konumu veya yeri seçin.
- TAVAN PANELİNİN üzerinde en az 250 mm veya daha fazla boş yükseklik gereklidir.
- Ürünün düşmesini önlemek için GÜVENLİK KABLOSUNU taktığınızdan emin olun.
- Montaj braketini ve kamerayı takmak için ürünle birlikte verilen vidaları kullanın.
- TAVAN PANELİ en az 10 kg ağırlığa dayanabilmelidir.

**SWE**

- Välj en installationsposition eller plats som kan hålla minst 4 gånger den totala vikten av installationsstrukturen.
- Minst 250 mm eller mer fritt utrymme krävs ovanför TAKSKIVAN.
- Se till att säkra SÄKERHETSLEDNINGEN så att produkten inte faller.
- Använd de medföljande skruvarna för att installera monteringsfästet och kameran.
- TAKSKIVAN måste kunna hålla en vikt på minst 10 kg.

**POR**

- Selecione um local ou posição de instalação capaz de aguentar mais de 4 vezes o peso total da estrutura de instalação.
- É necessário pelo menos 250 mm ou mais de espaço de sobra acima das PLACAS DO TETO.
- Certifique-se de prender o FIO DE SEGURANÇA para evitar a queda do produto.
- Use os parafusos fornecidos para instalar o suporte de montagem e a câmera.
- As PLACAS DO TETO precisam aguentar um peso de pelo menos 10 kg.

**JAP**

- インストールする製品の総重量の4倍以上を耐えられるインストール場所を選定してください。
- 天井ボードの上の空間が250mm以上になる場所にインストールしてください。
- 落下防止用の安全ワイヤーを必ず使用してインストールしてください。
- インストールブラケット&カメラを組み立てる時には提供されたネジを使用してください。
- 天井ボードは最小10kgの重量に耐えられる必要があります。

**CHI**

- 请选择一个可以承受要安装产品的总重4倍以上的安装位置。
- 请安装在天花板上方的空间为250mm以上的地方。
- 必须使用防止跌落安全线进行安装。
- 组装安装支架和摄像机时, 请使用随附的螺钉。
- 天花板必须能够支撑至少10kg的重量。

**KOR**

- 설치할 제품의 총 중량의 4배 이상을 견딜 수 있는 설치 장소를 선정하세요.
- 천장보드 위의 공간이 250mm 이상이 되는 장소에 설치하세요.
- 낙하방지용 안전와이어를 반드시 사용하여 설치하세요.
- 설치브라켓 및 카메라 조립시에는 제공된 나사를 사용하세요.
- 천장보드는 최소 10kg의 무게를 지탱할 수 있어야 합니다.

## Installation

- 1 Attach the TEMPLATE on the CEILING BOARD and drill a guided hole.

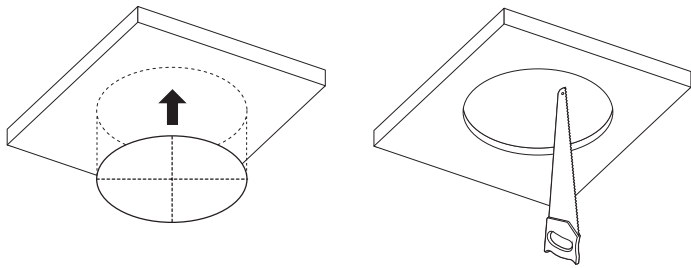

- 2 After checking the hole size to use, remove the cap and the hex nut.

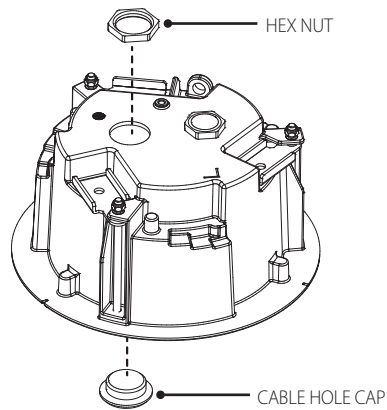

### Mounting combination table

When mounting camera to the housing, refer to the mounting combination table shown below:

- A/B/C/D : mounting bracket assembly hole

- A/B/C/D/E : camera assembly hole

- 1/2/3 : case top number

A - A - 1	B - B - 1	B - C - 2	B - D - 3	B - E - 1	C - C - 2	D - D - 3	
PND-9080R	QNV-6072R	QND-8080R	XNV-6010	HCV-6070R	HCD-6080R	HCV-7010R	HCV-7010RA
XND-6080	QNV-6082R		XNV-6020R	HCV-6080R	HCD-7070R	HCV-7020R	HCV-7020RA
XND-6080R	QNV-8080R		XNV-8020R	HCV-6080R	HCD-7070RA	HCV-7030R	HCV-7030RA
XND-6080RV	QNV-6070R		XNV-8030R	HCV-6080RSD	HCD-7080R	LNV-6011R	LNV-6021R
XND-6080V	QNV-6071R		XNV-8040R	HCV-7070R	LND-6071R	LNV-6031R	QNV-6010R
XND-8080R	QNV-7080R			HCV-7070RA	QND-6070R	QNV-6020R	QNV-6030R
XND-8080RV	QNV-7081R			HCV-7080R	QND-6071R	QNV-7010R	QNV-7020R
XND-L6080R	LNV-6071R			HCV-7080RVP	QND-7080R	QNV-7030R	LNV-6010R
XND-L6080RV	LNV-6070R				QND-7081R	LNV-6012R	LNV-6020R
XND-L6080V	LNV-6072R				LND-6070R	LNV-6022R	LNV-6030R
	XNP-6040H				LND-6072R	LNV-6032R	QNV-6012R
					QND-6072R	QNV-6022R	QNV-6032R
					QND-6082R	QNV-8010R	QNV-8020R
							QNV-8030R

- For more information on the mounting combination, check online using the QR code on the product.

- 3 Use a Phillips head screwdriver to join the camera mounting bracket to the housing.

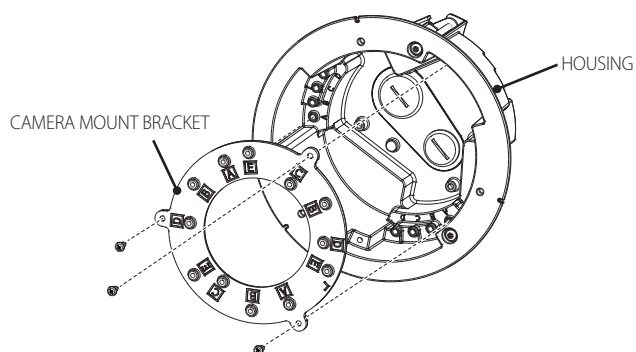

- When joining the camera mounting bracket, refer to the mounting combination table for the proper mounting hole of the housing.

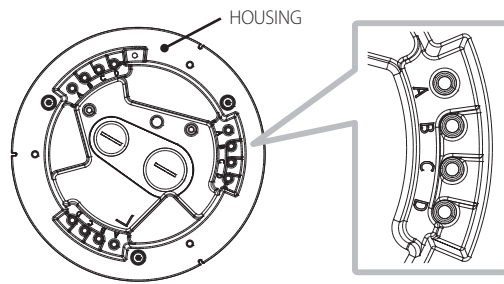

- 4 Fix the ANCHOR BOLT onto the concrete CEILING, and secure the SAFETY WIRE to the ANCHOR BOLT as below:

1. Tighten the NUT ("N1") on the ANCHOR BOLT.
2. Insert the provided SAFETY BRACKET into the ANCHOR BOLT.
3. Tighten two NUTS ("N2,""N3") onto the ANCHOR BOLT.
4. Hook and fix one end of the SAFETY WIRE onto the SAFETY BRACKET.
5. Hook and fix the other end of SAFETY WIRE onto the HOUSING as shown below:

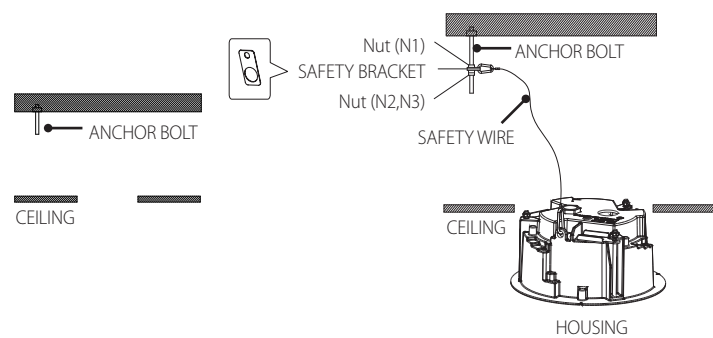

- The ANCHOR BOLTS and nuts are optional and not included in the product package.
- ANCHOR BOLTS must be able to sustain the weight of at least 30 kg.
  - If you proceed without following the instructions in the manual, that is if you work with the camera body already attached from the beginning, the safety wire could exceed its limit and be broken when the housing is accidentally dropped, which could result in an accident.

- 5 Push the HOUSING inside the CEILING through the CEILING hole, and tighten the SCREWS (x3) clockwise to fix the HOUSING on the CEILING. (Adjust the height of the bracket to secure the housing to the ceiling.)

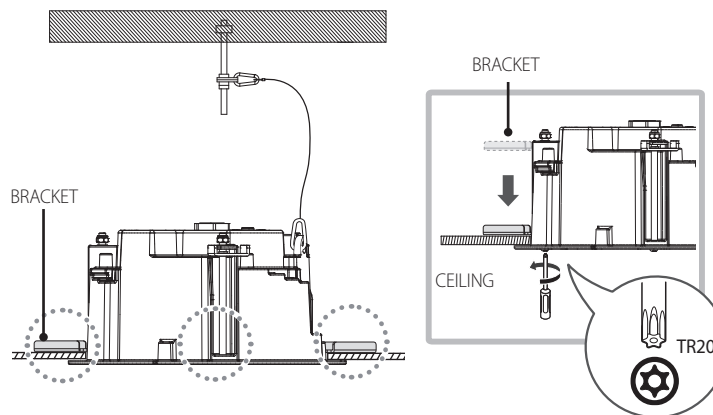

- Using a power tool for installation could cause product damage. If you are going to use a power tool, the torque must be 30 Nm or less.
- Ensure that the HOUSING is firmly secured to the CEILING BOARD.

- 6 Use the provided machine screws to join the camera to the camera mounting bracket inside the housing.

- For HCD-6080R, HCD-7070R, HCD-7070RA, and HCD-7080R models, assemble them using the screws provided as camera accessories.

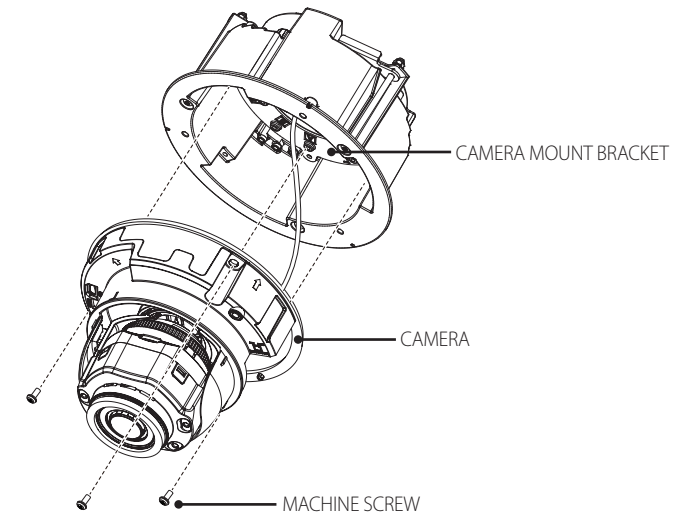

- When mounting the camera, refer to the mounting combination table to select the mounting holes appropriate to the camera size.

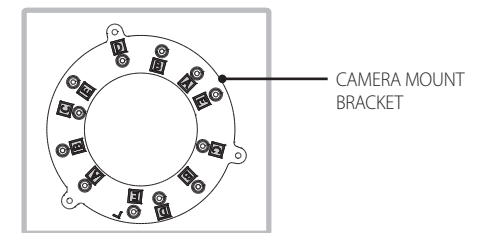

- 7 Attach the CASE TOP to the HOUSING, and tighten the 3 SCREWS on the COVER to fix it to the HOUSING.

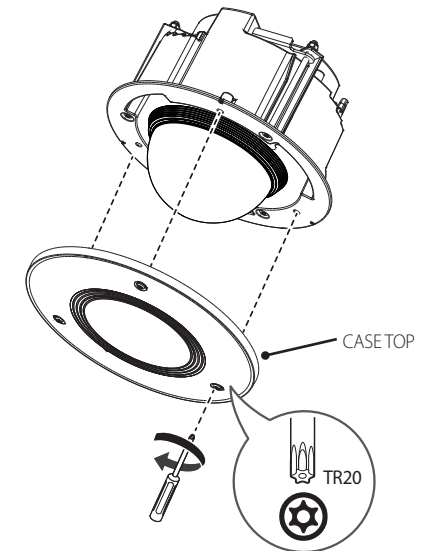

- Refer to the mounting combination table to use the case top appropriate to the dome cover size of the camera. To know the type of the case top, please check the number marked inside.

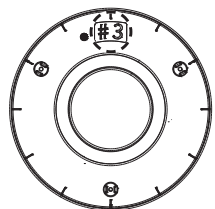

- 8 Insert the SCREW CAPS into the screw holes.

