



Cisco Catalyst IR1800 Rugged Series Router Hardware Installation Guide

First Published: 2021-02-03

Last Modified: 2023-04-21

Americas Headquarters

Cisco Systems, Inc.
170 West Tasman Drive
San Jose, CA 95134-1706
USA
<http://www.cisco.com>
Tel: 408 526-4000
800 553-NETS (6387)
Fax: 408 527-0883

The documentation set for this product strives to use bias-free language. For purposes of this documentation set, bias-free is defined as language that does not imply discrimination based on age, disability, gender, racial identity, ethnic identity, sexual orientation, socioeconomic status, and intersectionality. Exceptions may be present in the documentation due to language that is hardcoded in the user interfaces of the product software, language used based on standards documentation, or language that is used by a referenced third-party product.

Cisco and the Cisco logo are trademarks or registered trademarks of Cisco and/or its affiliates in the U.S. and other countries. To view a list of Cisco trademarks, go to this URL: <https://www.cisco.com/c/en/us/about/legal/trademarks.html>. Third-party trademarks mentioned are the property of their respective owners. The use of the word partner does not imply a partnership relationship between Cisco and any other company. (1721R)

© 2021–2023 Cisco Systems, Inc. All rights reserved.



CONTENTS

CHAPTER 1

Preface 1

- Preface 1
- Objective 1
- Audience 1
- Conventions 2
- Safety Warnings 2
- Related Documentation 7
- Searching Cisco Documents 7

CHAPTER 2

Product Overview 9

- Overview of Features 9
- Cisco IR1800 Series Platform Features 10
 - Cisco IR1821 Router 10
 - Cisco IR1831 Router 11
 - Cisco IR1833 Router 11
 - Cisco IR1835 Router 11
- Front Panel Overview 11
- Rear Panel Overview 12
- Pluggable Modules 13
 - Cellular Pluggable Interface Module (PIM) 13
 - SSD Module 13
 - GPS Module 13
 - SFP Modules 13
 - Wireless Interface Module (WIM) 15
- Gigabit Ethernet Combo Port 15
- Gigabit Ethernet Copper Ports 15

Power over Ethernet	15
Front Panel LEDs	15
Reset Button	17
Supported Cisco Antennas and Antenna Accessories	17
Modem Support	17
Power Supply	19
Serial Ports	19
USB Ports	20

CHAPTER 3**Installing the Router 23**

Overview	23
Safety Information	23
Equipment, Tools, and Connections	24
Items Shipped with Your Router	24
Additional Items	24
Installing the Router	25
Mounting on a Wall, Table, or Other Flat Surface	25
Installing a DIN Rail	27
Mounting the DIN Rail Bracket on the Router (Horizontal)	28
Attaching the Bracket to the DIN Rail	28
Changing the Bracket Orientation	30
Bracket Disassembly	31
Bracket Reassembly	33
Mounting the DIN Rail Bracket on the Router (Vertical)	34
Installing the Router Ground Connection	35

CHAPTER 4**Antenna Selection and Installation 37**

Introduction to Selecting Antennas	37
Antenna Installation Best Practices	37
Supported Antennas for the IR1800 Series Router	39
Pluggable Interface Modules	40
Wi Fi Modules	40
Indoor Antennas	40
Outdoor Antennas	41

Outdoor and Transportation Antennas	42
Supported Extension Bases and Cables	42

CHAPTER 5**Pluggable Interface Modules 43**

Introduction to Installing Pluggable Interface Modules	43
Installing a PIM	44

CHAPTER 6**5G Sub-6 GHz Pluggable Interface Module 51**

5G Sub-6 GHz Support on IoT Routing	51
5G Pluggable Interface Module Overview	52
LED Behaviors	53
RF Band and Port Mapping for the P-5GS6-GL Antenna	54
Thermal Mitigation	55
Attaching an Antenna	57

CHAPTER 7**Cisco Wi-Fi Interface Module (WIM) 59**

Overview	59
Installation	61
Transmit Power and Receive Sensitivity	63
Thermal Mitigation	66

CHAPTER 8**SSD Module 67**

Introduction to the Solid State Drive in the IR1800 Series	67
Installing an SSD Module	68

CHAPTER 9**GPS Field Replaceable Unit Module 71**

Overview of the GPS FRU Module	71
Installation and Removal of a GPS FRU Module	72

CHAPTER 10**Digital I/O, Ignition, and CAN Bus Connectivity 75**

Overview of the Digital I/O, Ignition, and CAN Bus Connectivity	75
Digital I/O Features	75
The Digital I/O Connector	75

Digital I/O Specifications 77

Controller Area Network Bus Features 77

 Can Bus Power Connector 78

On-Board Diagnostic (OBD-II) 78

CHAPTER 11

Connecting the Router 81

Overview of the IR1800 Connecting Process 81

Preparing to Connect the Router 81

 Preventing Damage to the Router 81

 Connecting a PC, Server, or Workstation 82

Connecting a PC to the Console Port 82

Connecting to DC Power and CAN Bus Wiring 83

 Plugs and Pinouts 83

Verifying Connections 84

CHAPTER 12

Installing the IP54 Kit 85

Overview of the IP54 Kit 85

Installing the IP54 Kit 87

 Installing the Front Cover 87

 Installing the Back Cover 89

CHAPTER 13

Technical Specifications 91

Overview of Technical Specifications for IR1800 Series Routers 91

Router Specifications 91

CHAPTER 14

Regulatory Compliance 93

Related Documentation 93

Installation Warning and Caution Statements 94

Hazardous Locations Standards and Marking Strings 95

EMC Information 96

Class A Notice for FCC 96

Industry Canada 97

 Canadian Compliance Statement 97

European Community, Switzerland, Norway, Iceland, and Liechtenstein 98

Declaration of Conformity with Regard to R-ED Directive 2014/53/EU	98
Declaration of Conformity for RF Exposure	98
RF Exposure	98
This Device Meets International Guidelines for Exposure to Radio Waves	99
This Device Meets FCC Guidelines for Exposure to Radio Waves	99
FCC Radiation Exposure Statement	100
This Device Meets the Industry Canada Guidelines for Exposure to Radio Waves	100
ISED Radiation Exposure Statement	101
Additional Information on RF Exposure	101
EMC Class A Notices and Warnings	101
Declaration of Conformity with Regard to EU Directive 2014/53/EU	102
National Restrictions	104
Denmark	104
Italy	104
Latvia	104
Brazil Regulatory Information	105
Taiwan	105
Statement 191—Voluntary Control Council for Interference (VCCI) Class A Warning for Japan	105
ステートメント 191—日本向け VCCI クラス A に関する警告	105
Statement 1008—Class 1 Laser Product	106
ステートメント 1008—クラス 1 レーザー製品	106
Statement 1051—Laser Radiation	106
ステートメント 1051: レーザー放射	106
Statement 1255—Laser Compliance Statement	106
聲明4011—國家通信委員會警告	107
Intended Use of equipment	107
Changing Output Power	107
Obtaining Documents from Cisco.com	107



CHAPTER 1

Preface

This preface contains the following sections:

- [Preface, on page 1](#)
- [Objective, on page 1](#)
- [Audience, on page 1](#)
- [Conventions, on page 2](#)
- [Safety Warnings, on page 2](#)
- [Related Documentation, on page 7](#)
- [Searching Cisco Documents, on page 7](#)

Preface

This preface describes the objectives, audience, organization, and conventions of this guide and describes related documents that have additional information.



Note The documentation set for this product strives to use bias-free language. For purposes of this documentation set, bias-free is defined as language that does not imply discrimination based on age, disability, gender, racial identity, ethnic identity, sexual orientation, socioeconomic status, and intersectionality. Exceptions may be present in the documentation due to language that is hardcoded in the user interfaces of the product software, language used based on RFP documentation, or language that is used by a referenced third-party product.

Objective

This guide provides an overview of and explains how to install and connect your Cisco Router.

Audience

This guide is intended for people who have a high level of technical ability, although they may not have experience with Cisco software.

Conventions

This section describes the conventions used in this guide.



Note Means reader take note. Notes contain helpful suggestions or references to additional information and material.



Caution This symbol means reader be careful. In this situation, you might do something that could result in equipment damage or loss of data.



Tip Means *the following information will help you solve a problem*. The tip information might not be troubleshooting or even an action, but could be useful information.



Warning Means danger. You are in a situation that could cause bodily injury. Before you work on any equipment, be aware of the hazards involved with electrical circuitry and be familiar with standard practices for preventing accidents. Use the statement number provided at the end of each warning to locate its translation in the translated safety warnings that accompanied this device.

Safety Warnings

Warning	This warning symbol means danger. You are in a situation that could cause bodily injury. Before you work on any of the hazards involved with electrical circuitry and be familiar with standard practices for preventing accidents. Use the statement number provided at the end of each warning to locate its translation in the translated safety warnings that accompanied this device. Statement 1071
Waarschuwing	BELANGRIJKE VEILIGHEIDSINSTRUCTIES Dit waarschuwingssymbool betekent gevaar. U verkeert in een situatie die lichamelijk letsel kan veroorzaken. Voordat u aan elektrische apparatuur gaat werken, dient u zich bewust te zijn van de bij elektrische schakelingen betrokken risico's en dient u zich te onthouden van standaard praktijken om ongelukken te voorkomen. Gebruik het nummer van de verklaring onderaan de afbeelding van de waarschuwing die bij het apparaat wordt geleverd, wilt raadplegen. BEWAAR DEZE INSTRUCTIES
Varoitus	TÄRKEITÄ TURVALLISUUSOHJEITA Tämä varoitusmerkki merkitsee vaaraa. Tilanne voi aiheuttaa ruumiillisia vammoja. Ennen kuin käsittelet laitteistoasi, on tärkeää tutustua sähköasennukseen liittyvät riskit ja tutustu onnettomuuksien yleisiin ehkäisytapoihin. Turvallisuusvaroitusten käännökset löydät ohjeiden mukana toimitettujen käännettyjen turvallisuusvaroitusten joukosta varoitusten lopussa näkyvien lausuntonumeroiden avulla. SÄILYTÄ NÄMÄ OHJEET

Attention	<p>IMPORTANTES INFORMATIONS DE SÉCURITÉ</p> <p>Ce symbole d'avertissement indique un danger. Vous vous trouvez dans une situation pouvant entraîner des blessures corporels. Avant de travailler sur un équipement, soyez conscient des dangers liés aux circuits électriques et suivez les procédures couramment utilisées pour éviter les accidents. Pour prendre connaissance des traductions des avis de sécurité et des consignes de sécurité traduites qui accompagnent cet appareil, référez-vous au numéro de l'instruction situé sur l'avertissement.</p> <p>CONSERVEZ CES INFORMATIONS</p>
Warnung	<p>WICHTIGE SICHERHEITSHINWEISE</p> <p>Dieses Warnsymbol bedeutet Gefahr. Sie befinden sich in einer Situation, die zu Verletzungen führen kann. Bei der Arbeit mit Geräten mit den Gefahren elektrischer Schaltungen und den üblichen Verfahren zur Vorbeugung von Unfällen. Suchen Sie mit der am Ende jeder Warnung angegebenen Anweisungsnummer nach der jeweiligen Übersetzung der Sicherheitshinweisen, die zusammen mit diesem Gerät ausgeliefert wurden.</p> <p>BEWAHREN SIE DIESE HINWEISE GUT AUF.</p>
Avvertenza	<p>IMPORTANTI ISTRUZIONI SULLA SICUREZZA</p> <p>Questo simbolo di avvertenza indica un pericolo. La situazione potrebbe causare infortuni alle persone. Prima dell'installazione e dell'uso dell'apparecchiatura, occorre essere al corrente dei pericoli relativi ai circuiti elettrici e conoscere le procedure standard di prevenzione degli incidenti. Utilizzare il numero di istruzione presente alla fine di ciascuna avvertenza per individuare le traduzioni riportate in questo documento.</p> <p>CONSERVARE QUESTE ISTRUZIONI</p>
Advarsel	<p>VIKTIGE SIKKERHETSINSTRUKSJONER</p> <p>Dette advarselssymbolet betyr fare. Du er i en situasjon som kan føre til skade på person. Før du begynner å arbeide, må du være oppmerksom på farene forbundet med elektriske kretser, og kjenne til standardprosedyrer for å forhindre ulykker. Nummeret i slutten av hver advarsel for å finne oversettelsen i de oversatte sikkerhetsadvarslene som fulgte med dette dokumentet.</p> <p>TA VARE PÅ DISSE INSTRUKSJONENE</p>
Aviso	<p>INSTRUÇÕES IMPORTANTES DE SEGURANÇA</p> <p>Este símbolo de aviso significa perigo. Você está em uma situação que poderá ser causadora de lesões corporais. Antes de utilizar qualquer equipamento, tenha conhecimento dos perigos envolvidos no manuseio de circuitos elétricos e siga as práticas habituais de prevenção de acidentes. Utilize o número da instrução fornecido ao final de cada tradução nos avisos de segurança traduzidos que acompanham este dispositivo.</p> <p>GUARDE ESTAS INSTRUÇÕES</p>
¡Advertencia!	<p>INSTRUCCIONES IMPORTANTES DE SEGURIDAD</p> <p>Este símbolo de aviso indica peligro. Existe riesgo para su integridad física. Antes de manipular cualquier equipo, asegurese de la corriente eléctrica y familiarícese con los procedimientos estándar de prevención de accidentes. Al final de cada traducción encontrará el número que le ayudará a encontrar el texto traducido en el apartado de traducciones que acompaña a este documento.</p> <p>GUARDE ESTAS INSTRUCCIONES</p>

<p>Varning!</p>	<p>VIKTIGA SÄKERHETSANVISNINGAR</p> <p>Denna varningssignal signalerar fara. Du befinner dig i en situation som kan leda till personskada. Innan du utför utrustning måste du vara medveten om farorna med elkretsar och känna till vanliga förfaranden för att förebygga olyckor. Använd alltid försiktighetsnummer som finns i slutet av varje varning för att hitta dess översättning i de översatta säkerhetsvarningar som finns i denna anordning.</p> <p>SPARA DESSA ANVISNINGAR</p>
<p>Figyelem</p>	<p>FONTOS BIZTONSÁGI ELOÍRÁSOK</p> <p>Ez a figyelmeztető jel veszélyre utal. Sérülésveszélyt rejte helyzetben van. Mielőtt bármely berendezésen munkát végezte, legyen figyelmezzel az elektromos áramkörök okozta kockázatokra, és ismerkedjen meg a szokásos balesetvédelmi eljárásokkal. A kiadványban szereplő figyelmeztetések fordítása a készülékhez mellékelt biztonsági figyelmeztetések között található; a fordítás az egyes figyelmeztetések végén látható szám alapján kereshető meg.</p> <p>ORIZZE MEG EZEKET AZ UTASÍTÁSOKAT!</p>
<p>Предупреждение</p>	<p>ВАЖНЫЕ ИНСТРУКЦИИ ПО СОБЛЮДЕНИЮ ТЕХНИКИ БЕЗОПАСНОСТИ</p> <p>Этот символ предупреждения обозначает опасность. То есть имеет место ситуация, в которой следует опасаться телесных повреждений. Перед эксплуатацией оборудования выясните, каким опасностям может подвергаться пользователь при использовании электрических цепей, и ознакомьтесь с правилами техники безопасности для предотвращения возможных несчастных случаев. Воспользуйтесь номером заявления, приведенным в конце каждого предупреждения, чтобы найти его переведенный вариант в переводе предупреждений по безопасности, прилагаемом к данному устройству.</p> <p>СОХРАНИТЕ ЭТИ ИНСТРУКЦИИ</p>
<p>警告</p>	<p>重要的安全性说明</p> <p>此警告符号代表危险。您正处于可能受到严重伤害的工作环境中。在您使用设备开始工作之前，必须充分意识到触电的危险，并熟练掌握防止事故发生的标准工作程序。请根据每项警告结尾提供的声明号码来找到此设备的安全性警告说明的翻译文本。</p> <p>请保存这些安全性说明</p>
<p>警告</p>	<p>安全上の重要な注意事項</p> <p>「危険」の意味です。人身事故を予防するための注意事項が記述されています。装置の取り扱いは、事前に作業を始める前に電気回路の危険性に注意し、一般的な事故防止策に留意してください。警告の各国語版は、各注意事項の番号を基に、装置に付属の「Translated Safety Warnings」を参照してください。</p> <p>これらの注意事項を保管しておいてください。</p>
<p>주의</p>	<p>중요 안전 지침</p> <p>이 경고 기호는 위험을 나타냅니다. 작업자가 신체 부상을 일으킬 수 있는 위험한 환경에 있습니다. 장비에 작업을 수행하기 전에 전기 회로와 관련된 위험을 숙지하고 표준 작업 관례를 숙지하여 사고를 방지하십시오. 각 경고의 마지막 부분에 있는 경고문 번호를 참조하여 이 장치와 함께 제공되는 번역된 안전 경고문에서 해당 번역문을 찾으십시오.</p> <p>이 지침 사항을 보관하십시오.</p>
<p>Aviso</p>	<p>INSTRUÇÕES IMPORTANTES DE SEGURANÇA</p> <p>Este símbolo de aviso significa perigo. Você se encontra em uma situação em que há risco de lesões corporais. Ao utilizar qualquer equipamento, esteja ciente dos riscos que envolvem os circuitos elétricos e familiarize-se com as práticas de segurança para evitar acidentes. Use o número da declaração fornecido ao final de cada aviso para localizar sua tradução nos avisos de segurança que acompanham o dispositivo.</p> <p>GUARDE ESTAS INSTRUÇÕES</p>
<p>Advarsel</p>	<p>VIGTIGE SIKKERHEDSANVISNINGER</p> <p>Dette advarselssymbol betyder fare. Du befinner dig i en situation med risiko for legemesbeskadigelse. Før du bruger udstyr, skal du være opmærksom på de involverede risici, der er ved elektriske kredsløb, og du skal sætte dig ind på de sikkerhedsregler, der gælder for at undgå ulykker. Brug erklæringsnummeret efter hver advarsel for at finde oversættelsen i de oversatte advarselskort, der følger med denne enhed.</p> <p>GEM DISSE ANVISNINGER</p>
<p>تحذير</p>	<p>إرشادات الأمان الهامة</p> <p>يوضح رمز التحذير هذا وجود خطر. وهذا يعني أنك متواجد في مكان قد ينتج عنه التعرض لإصابات. قبل بدء العمل، احذر مخاطر التعرض للخدمات الكهربائية وكن على علم بالإجراءات القياسية للتعامل مع المعدات دون وقوع أي حوادث. استخدم رقم البيان الموجود في آخر كل تحذير لتحديد مكان ترجمته داخل تحذيرات الأمان المترجمة التي تأتي مع الجهاز. قم بحفظ هذه الإرشادات</p>

<p>Upozorenje</p>	<p>VAŽNE SIGURNOSNE NAPOMENE</p> <p>Ovaj simbol upozorenja predstavlja opasnost. Nalazite se u situaciji koja može prouzročiti tjelesne ozljede. Prije rada s bilo kojim uređajem, morate razumjeti opasnosti vezane uz električne sklopove, te biti upoznati sa standardnim načinima izbjegavanja nesreća. U preveđenim sigurnosnim upozorenjima, priloženima uz uređaj, možete prema broju koji se nalazi uz pojedino upozorenje pronaći i njegov prijevod.</p> <p>SACUVAJTE OVE UPUTE</p>
<p>Upozornění</p>	<p>DŮLEŽITÉ BEZPEČNOSTNÍ POKYNY</p> <p>Tento upozorňující symbol označuje nebezpečí. Jste v situaci, která by mohla způsobit nebezpečí úrazu. Před prací na jakémkoliv vybavení si uvědomte nebezpečí související s elektrickými obvody a seznámte se se standardními opatřeními pro předcházení úrazům. Podle čísla na konci každého upozornění vyhledejte jeho překlad v přeložených bezpečnostních upozorněních, která jsou přiložena k zařízení.</p> <p>USCHOVEJTE TYTO POKYNY</p>
<p>Προειδοποίηση</p>	<p>ΣΗΜΑΝΤΙΚΕΣ ΟΔΗΓΙΕΣ ΑΣΦΑΛΕΙΑΣ</p> <p>Αυτό το προειδοποιητικό σύμβολο σημαίνει κίνδυνο. Βρίσκεστε σε κατάσταση που μπορεί να προκαλέσει τραυματισμό. Πριν εργαστείτε σε οποιοδήποτε εξοπλισμό, να έχετε υπόψη σας τους κινδύνους που σχετίζονται με τα ηλεκτρικά κυκλώματα και να έχετε εξοικειωθεί με τις συνήθεις πρακτικές για την ασφαλή λειτουργία. Χρησιμοποιήστε τον αριθμό δήλωσης που παρέχεται στο τέλος κάθε προειδοποίησης, για να εντοπίσετε τη μετάφρασή της στις μεταφρασμένες προειδοποιήσεις ασφαλείας που συνοδεύουν τη συσκευή.</p> <p>ΦΥΛΑΞΤΕ ΑΥΤΕΣ ΤΙΣ ΟΔΗΓΙΕΣ</p>
<p>אזהרה</p>	<p>הוראות בטיחות חשובות</p> <p>סימן אזהרה זה מסמל סכנה. אתם נמצאים במצב העלול לגרום לפגיעה. לפני שתעבוד עם ציוד חשמלי, עליך להיות מודע לסכנות הכרוכות במגע עם שמלילים ולהכיר את הנחלים המקובלים למניעת תאונות. השתמש במספר ההוראה המסופק בסופה של כל אזהרה כדי לאתר את התרגום באזהרות הבטיחות המתורגמות שמצורפות להלן.</p> <p>שמור הוראות אלה</p>
<p>Opomena</p>	<p>ВАЖНИ БЕЗБЕДНОСНИ НАПАТСТВИЈА</p> <p>Симболот за предупредување значи опасност. Се наоѓате во ситуација што може да предизвика телесни повреди. Пред да работите со опремата, бидете свесни за ризикот што постои кај електричните кола и треба да ги познавате стандардните постапки за спречување на несреќни случаи. Искористете го бројот на којавата што се наоѓа на крајот на секоје предупредување за да го најдете неговиот период во преведените безбедносни предупредувања што се испорачани со уредот.</p> <p>ЧУВАЈТЕ ГИ ОБИЕ НАПАТСТВИЈА</p>
<p>Ostrzeżenie</p>	<p>WAŻNE INSTRUKCJE DOTYCZĄCE BEZPIECZEŃSTWA</p> <p>Ten symbol ostrzeżenia oznacza niebezpieczeństwo. Zachodzi sytuacja, która może powodować obrażenia ciała. Przed przystąpieniem do prac przy urządzeniach należy zapoznać się z zagrożeniami związanymi z układami elektrycznymi oraz ze standardowymi środkami zapobiegania wypadkom. Na końcu każdego ostrzeżenia podano numer, na podstawie którego można odszukać tłumaczenie tego ostrzeżenia w dołączonym do urządzenia dokumencie z tłumaczeniami ostrzeżeń.</p> <p>NINIEJSZE INSTRUKCJE NALEŻY ZACHOWAĆ</p>
<p>Upozornenie</p>	<p>DŮLEŽITÉ BEZPEČNOSTNÉ POKYNY</p> <p>Tento varovný symbol označuje nebezpečenstvo. Nachádzate sa v situácii s nebezpečenstvom úrazu. Pred prácou na akomkoľvek vybavení si uvedomte nebezpečenstvo súvisiace s elektrickými obvodmi a oboznámte sa so štandardnými opatreniami na predchádzanie úrazom. Podľa čísla na konci každého upozornenia vyhľadajte jeho preklad v preložených bezpečnostných upozorneniach, ktoré sú priložené k zariadeniu.</p> <p>USCHOVAJTE SI TENTO NÁVOD</p>
<p>Opozorilo</p>	<p>Ta naprava mora biti ozemljena. Nikoli ne odklapljajte ozemljitve oz. upravljajte naprave, ki ni primerno ozemljena. V primeru, da niste sigurni, ali imate primerno ozemljitev, nemudoma pokličite pooblaščen električni servis ali električarja.</p>
<p>警告</p>	<p>重要安全性指示</p> <p>此警告符號代表危險，表示可能造成人身傷害。使用任何設備前，請留心電路相關危險，並熟悉避免意外的標準作法。您可以使用每項警告後的聲明編號，查詢本裝置隨附之安全性警告譯文中的翻譯。請妥善保留此指示。</p>



Warning

When installing the product, please use the provided or designated connection cables/power cables/AC adapters. Using any other cables/adapters could cause a malfunction or a fire. Electrical Appliance and Material Safety Law prohibits the use of UL-certified cables (that have the “UL” shown on the code) for any other electrical devices than products designated by CISCO. The use of cables that are certified by Electrical Appliance and Material Safety Law (that have “PSE” shown on the code) is not limited to CISCO-designated products.

Statement 371



Warning Read the wall-mounting instructions carefully before beginning installation. Failure to use the correct hardware or to follow the correct procedures could result in a hazardous situation to people and damage to the system. **Statement 378**



Warning Read the installation instructions before connecting the system to the power source. **Statement 1004**



Warning Class 1 laser product. **Statement 1008**



Warning To avoid electric shock, do not connect safety extra-low voltage (SELV) circuits to telephone-network voltage (TNV) circuits. LAN ports contain SELV circuits, and WAN ports contain TNV circuits. Some LAN and WAN ports both use RJ-45 connectors. Use caution when connecting cables. **Statement 1021**



Warning This equipment must be grounded. Never defeat the ground conductor or operate the equipment in the absence of a suitably installed ground conductor. Contact the appropriate electrical inspection authority or an electrician if you are uncertain that suitable grounding is available. **Statement 1024**



Warning Connect the unit only to DC power source that complies with the safety extra-low voltage (SELV) requirements in IEC 62368 and IEC 60950 based safety standards. **Statement 1033**



Warning When installing or replacing the unit, the ground connection must always be made first and disconnected last. **Statement 1046**



Warning Do not locate the antenna near overhead power lines or other electric light or power circuits, or where it can come into contact with such circuits. When installing the antenna, take extreme care not to come into contact with such circuits, because they may cause serious injury or death. For proper installation and grounding of the antenna, please refer to national and local codes (for example, U.S.:NFPA 70, National Electrical Code, Article 810, Canada: Canadian Electrical Code, Section 54). **Statement 1052**



Warning No user-serviceable parts inside. Do not open. **Statement 1073**



Warning Installation of the equipment must comply with local and national electrical codes. **Statement 1074**



Warning Only trained and qualified personnel should be allowed to install, replace, or service this equipment. **Statement 1030**



Warning Ultimate disposal of this product should be handled according to all national laws and regulations. **Statement 1040**



Warning The covers are an integral part of the safety design of the product. Do not operate the unit without the covers installed. **Statement 1077**



Warning Hot surface. **Statement 1079**



Warning Intended for installation in a restricted access location.

Related Documentation

All of the IR1101 documentation can be found online here:

<https://www.cisco.com/c/en/us/support/routers/1101-industrial-integrated-services-router/model.html>

Searching Cisco Documents

To search an HTML document using a web browser, press **Ctrl-F** (Windows) or **Cmd-F** (Apple). In most browsers, the option to search whole words only, invoke case sensitivity, or search forward and backward is also available.

To search a PDF document in Adobe Reader, use the basic Find toolbar (**Ctrl-F**) or the Full Reader Search window (**Shift-Ctrl-F**). Use the Find toolbar to find words or phrases within a specific document. Use the Full Reader Search window to search multiple PDF files simultaneously and to change case sensitivity and other options. Adobe Reader's online help has more information about how to search PDF documents.



CHAPTER 2

Product Overview

This chapter contains the following sections:

- [Overview of Features, on page 9](#)
- [Cisco IR1800 Series Platform Features, on page 10](#)
- [Front Panel Overview, on page 11](#)
- [Rear Panel Overview, on page 12](#)
- [Pluggable Modules, on page 13](#)
- [Gigabit Ethernet Combo Port, on page 15](#)
- [Gigabit Ethernet Copper Ports, on page 15](#)
- [Power over Ethernet, on page 15](#)
- [Front Panel LEDs, on page 15](#)
- [Reset Button, on page 17](#)
- [Supported Cisco Antennas and Antenna Accessories, on page 17](#)
- [Modem Support, on page 17](#)
- [Power Supply, on page 19](#)
- [Serial Ports, on page 19](#)
- [USB Ports, on page 20](#)

Overview of Features

This chapter provides an overview of the features available in the Cisco Catalyst IR1800 Rugged Series Router (referred to as the IR1800 in the rest of this document).

The IR1800 is a next-generation modular industrial router based on Cisco IOS-XE, with advanced features such as modular Wi-Fi, modular cellular WAN, Controller Area Network (CAN bus), solid-state drive (SSD), digital I/O, and GPS dead reckoning.

The IR1800 features a base platform with modularity that includes:

- Pluggable Interface Module (PIM) slot(s)
- Wi-fi Interface Module (WIM) slot
- SSD Module slot
- GPS Module slot

The IR1800 consists of four SKUs:

- IR1821

- IR1831
- IR1833
- IR1835

The following table shows the differences among the features of these SKUs.

Table 1: Differences in IR1800 SKU Features

Feature	IR1821	IR1831	IR1833	IR1835
Processor Frequency	600 MHz	600 MHz	600 MHz	1200 MHz
DDR Memory	4GB	4GB	4GB	8GB
Flash Storage	4GB	4GB	4GB	8GB
PIM Slot	1	2	2	2
Wi-Fi Pluggable Module Slot	1	1	1	1
PoE	No	No	Yes	Yes
SSD Module Slot	No	No	Yes	Yes
GPS FRU Module Slot	No	No	Yes	Yes
Digital I/O	No	No	No	Yes
Asynchronous Serial Interface	(1) RS232 DTE	(1) RS232 DTE (1) RS232 DCE	(1) RS232 DTE (1) RS232 DCE	(1) RS232 DTE (1) RS232 DCE/RS485

Cisco IR1800 Series Platform Features

This section describes the different components of the router.

Cisco IR1821 Router

Figure 1: Cisco IR1821 Router

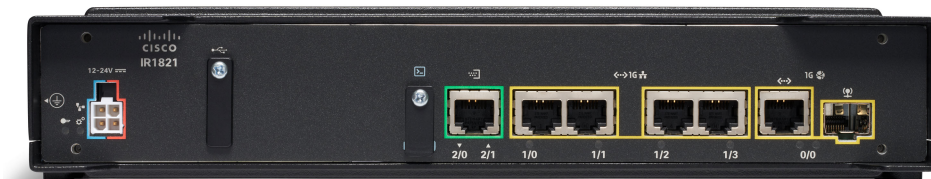

Cisco IR1831 Router

Figure 2: Cisco IR1831 Router



Cisco IR1833 Router

Figure 3: Cisco IR1833 Router

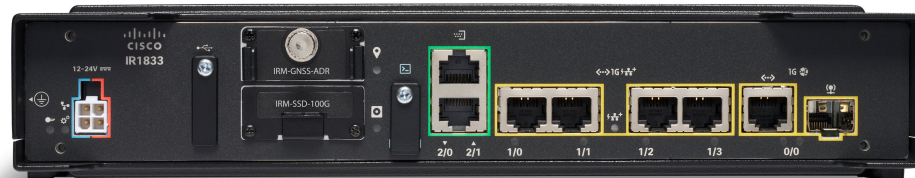

Cisco IR1835 Router

Figure 4: Cisco IR1835 Router



Front Panel Overview

This section describes the components of the IR1800 router. The IR1835 is used as an example since this SKU is the full featured router.

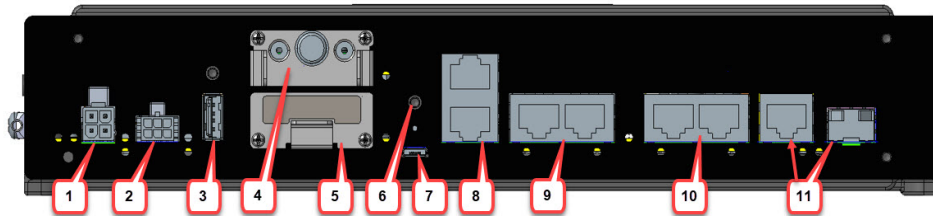
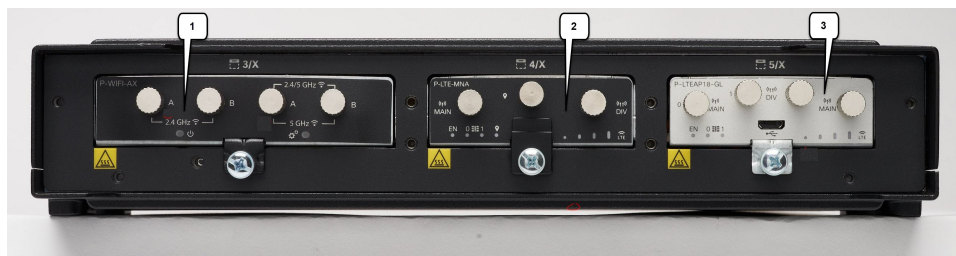

Table 2: Front Panel of the IR1835 Router

Item	Description
1	Power Connector/CAN Bus High/Low wiring
2	Digital I/O connector with Ignition Wiring
3	Type A USB 2.0
4	GPS FRU Module
5	SSD FRU Module
6	Reset Button
7	USB Console (Micro-B)
8	Asynchronous Serial Ports
9	Gigabit Ethernet LAN ports 0/1/0-0/1/1
10	Gigabit Ethernet LAN ports 0/1/2-0/1/3
11	Gigabit Ethernet 0/0/0 WAN Combo Ports (RJ-45 or SFP)

Rear Panel Overview

This section describes the components of the IR1800 router. The IR1835 is used as an example since this SKU is the full featured router.



Item	Description
1	Wi-Fi Interface Module (WIM) 0/3/0

Item	Description
2	Pluggable Interface Module 0/4/0 (PIM)
3	Pluggable Interface Module 0/5/0 (PIM)

Pluggable Modules

The following subsections provide details on the different modules that can be plugged into the IR1800 Series Routers.

Cellular Pluggable Interface Module (PIM)

The Cellular Pluggable Interface Module (PIM) is a pluggable unit used to connect to a wireless (LTE) interface. For more information about the PIM, see [Pluggable Interface Modules, on page 43](#).

SSD Module

The IR1800 supports one Solid State Drive (SSD) module. For more information see [SSD Module, on page 67](#).

GPS Module

The IR1800 supports one GPS module. This module is used in addition to the ones integrated in the pluggable LTE module for more accurate dead reckoning performance.

For more information about the module see [GPS Field Replaceable Unit Module, on page 71](#).

SFP Modules



Warning Class 1 laser product. **Statement 1008**

The IR1800 Ethernet SFP module provides connections to other devices. These field-replaceable transceiver modules provide uplink interfaces. Local connectors provide the fiber-optic connection. RJ-45 connectors allow copper connections. You can use any combination of the supported SFP modules listed in the following table.

Table 3: Supported Gigabit Ethernet SFPs

Gigabit Ethernet SFP	Distance	Fiber	Commercial 0C to +70C	Extended -5C to +85C	Industrial -40C to +85C	Digital Optical Monitoring
GLC-SX-MM-RGD	220-550 m	MMF	—	—	YES	—

Gigabit Ethernet SFP	Distance	Fiber	Commercial 0C to +70C	Extended -5C to +85C	Industrial -40C to +85C	Digital Optical Monitoring
GLC-LX-SM-RGD	550m/10 km	MMF/SMF	—	—	YES	—
GLC-ZX-SM-RGD	70 km	SMF	—	—	YES	YES
SFP-GE-S	220-550 m	MMF	—	YES	—	YES
SFP-GE-L	550 m/10 km	MMF/SMF	—	YES	—	YES
SFP-GE-Z	70 km	SMF	—	YES	—	YES

Table 4: Supported Fast Ethernet SFPs

Fast Ethernet SFP	Distance	Fiber	Commercial 0C ~ +70C	Extended -5C ~ +85C	Industrial -40C ~ +85C	Digital Optical Monitoring
GLC-FE-100FX-RGD	2 km	MMF	—	—	YES	—
GLC-FE-100LX-RGD	10 km	SMF	—	—	YES	—

Table 5: Supported SFPs added in IOS XE 17.7.1

SFP	Distance	Fiber	Commercial 0C ~ +70C	Extended -5C ~ +85C	Industrial -40C ~ +85C	Digital Optical Monitoring
GLC-T-RGD	100 M	Copper	—	—	YES	—
CWDM-SFP-1470	100 km	Duplex	YES	—	—	YES
CWDM-SFP-1610	100 km	Duplex	YES	—	—	YES
CWDM-SFP-1530	100 km	Duplex	YES	—	—	YES
DWDM-SFP-3033	80 km	Duplex	YES	—	—	YES
DWDM-SFP-3112	80 km	Duplex	YES	—	—	YES
GLC-BX-D-I	10 km	Single Strand	—	—	YES	YES
GLC-BX-U-I	10 km	Single Strand	—	—	YES	YES
GLC-TE	100 m	Copper	—	—	YES	NO

For the most up-to-date list of supported SFP models for Cisco Industrial Devices, see the [Cisco Optics-to-Device Compatibility Matrix](#).

Wireless Interface Module (WIM)

The Wireless Interface Module (WIM)

Complete details on the WIM are found in this chapter: [Cisco Wi-Fi Interface Module \(WIM\)](#), on page 59

Gigabit Ethernet Combo Port

The IR1800 supports a single combo fiber and copper port (SFP/RJ45). The SFP supports standard 1000Base-X or 100Base-FX Ethernet over single-mode or multi-mode optics. Industrial SFPs must be used for the system to meet the operating temperature from -40C to +60C. If commercial or extended temperature grade of SFP is used, the system's operating temperature must be derated.

Gigabit Ethernet Copper Ports

The IR1800 has four RJ-45 copper ports. These copper ports support standard 3-speed, 10/100/1000Base-T Ethernet features, including automatic medium-dependent interface crossover (auto-MDIX), forced or auto negotiation of speed and duplex, fast link drop, and cable diagnostics.

Power over Ethernet

A 30.8W capacity PoE PSE power supply is built into the IR1800. The power supply can power any of the LAN switch ports that are compliant with PoE and PoE+ 802.3af and 802.3at Powered Device (PD) specification, subject to 30.8 W maximum power shared among all ports.

Front Panel LEDs

The following figure shows the locations of the LEDs.

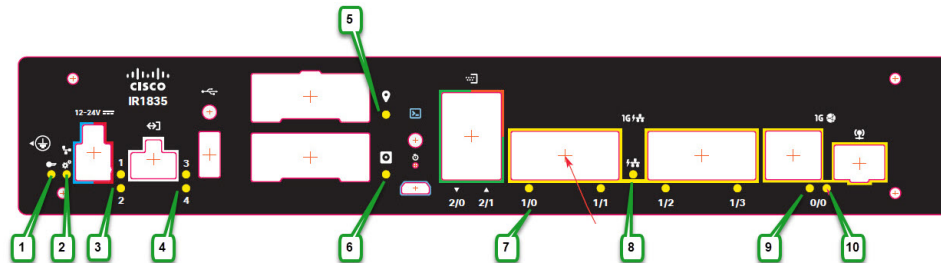

Table 6: LED Descriptions

LED Number	Description	LED Status
1	Ignition Status	<p>Off: Ignition power management is disabled when SYS LED is on.</p> <p>Steady Green combined with SYS LED Off: Ignition signal is off (power management is enabled).</p> <p>Steady Green combined with SYS LED On: Ignition signal is on.</p> <p>Flashing Green with Ignition Off: Timer counts down when SYS LED is on.</p> <p>Steady Yellow: Ignition power management feature is not loaded.</p>
2	System Status	<p>Steady Green: Operational.</p> <p>Flashing Green: Cisco IOS-XE booting.</p> <p>Steady Yellow: System in ROMMON mode.</p> <p>Off: No power.</p>
3 and 4	Digital I/O	<p>Off: Inactive.</p> <p>Steady Yellow: Active.</p>
5	GPS Module	<p>Steady Green: GPS/DR configured; location fix achieved.</p> <p>Flashing Green: GPS DR active; trying to achieve location fix.</p> <p>Off: GPS DR not configured.</p>
6	SSD Module	<p>Steady Green: SSD is being accessed.</p> <p>Off: No power or is not enabled.</p>
7	<p>Four Gigabit Ethernet LAN ports labeled 1/0, 1/1, 1/2, 1/3</p> <p>Note See the IR1800 Software Configuration Guide for Cisco IOS-XE naming conventions.</p>	<p>Steady Green: Port is up with link.</p> <p>Flashing Green: Link with activity.</p> <p>Off: Port is off or down.</p>
8	PoE Power Status	<p>Steady Green: POE or POE+ power supplied on one LAN Port.</p> <p>Off: No POE or POE+ power in any LAN port.</p>
9	<p>RJ45 Gigabit Ethernet WAN</p> <p>Note Either the SFP or the RJ45 LED will be On, depending on what type of interface is used in the combo port.</p>	<p>Steady Green: Port is up with link.</p> <p>Flashing Green: Link with activity.</p> <p>Off: No link, or port is off.</p>

LED Number	Description	LED Status
10	SFP Gigabit Ethernet WAN Note Either the SFP or the RJ45 LED will be On, depending on what type of interface is used in the combo port.	Steady Green: Port is up with link. Flashing Green: Link with activity. Off: No link, or port is off.

Reset Button

The **Reset** button resets the router configuration to the default factory configuration. To perform the reset, use a standard size #1 paper clip with wire gauge 0.033 inch or smaller, and simultaneously press the Reset button while applying power to the router.



Note The reset button does not cause a reset while the device is running.

Supported Cisco Antennas and Antenna Accessories

The IR1800 must have a pluggable module with antenna ports installed in order to connect to antennas. The base unit does not have any wireless capabilities on its own.

The Chapter [Antenna Selection and Installation, on page 37](#) lists the supported antennas and accessories for the IR1800 with a wireless pluggable module. For detailed information about Cisco antennas for industrial routers, see the [Cisco Industrial Routers and Industrial Wireless Access Points Antenna Guide](#).



Note We strongly recommend against having antennas attached directly to the router. It is better to use cables attached directly to the router.

Modem Support

Software download for the pluggable modules supported in the IR1800 is available at:

<https://software.cisco.com/download/navigator.html?mdfid=286288566&flowid=76082>

The following tables show the technology details for the modems.

Table 7: Modem Technology Supported

SKU ID	Description	Supported Technology
P-LTE-VZ	U.S. (Verizon) Single Micro SIM	LTE CAT4: B4, B13

SKU ID	Description	Supported Technology
P-LTE-US	North America (AT&T) Dual Micro SIM	LTE CAT4: B2, B4, B5, B12 HSPA+,UMTS: B2, B4, B5
P-LTE-GB	Europe Dual Micro SIM	LTE CAT4: B3, B5, B8, B20, B28 HSPA+: B1, B5, B8 EDGE: 900/1800
P-LTE-IN	India and China	LTE CAT4: B1, B3, B5, B8, B40, B41* * B41—supported frequency range: (2535–2655 MHz) 3G UMTS DC-HSPA+
P-LTE-MNA	North America	LTE CAT4: B2, B4, B5, B12, B13, B14, B17, B66 3G UMTS DC-HSPA+, HSPA+, HSPA, WCDMA
P-LTEA-LA	APAC	LTE Bands: B1, B3, B5, B7, B8, B18, B19, B21, B28, B38, B39, B40, B41 Non-LTE Bands: B87 - WCDMA (Europe, Japan, and China) 2100 band B91 - WCDMA US 850 band B92 - WCDMA Japan 800 band B114 - WCDMA Europe and Japan 900 band B115 - WCDMA Japan 1700 band B125 - WCDMA Japan 850 band
P-LTEA-EA	USA, Canada, Europe, Latin America	LTE bands: Bands 1-5, 7, 12, 13, 20, 25, 26, 29, 30 Non-LTE bands: B87 - WCDMA (Europe, Japan, and China) 2100 band B88 - WCDMA US PCS 1900 band B89 - WCDMA (Europe and China) DCS 1800 band B90 - WCDMA US 1700 band B91 - WCDMA US 850 band B114 - WCDMA Europe and Japan 900 band

SKU ID	Description	Supported Technology
P-LTEAP18-GL	United States, Europe, Canada, Japan, Australia, New Zealand and Private LTE or U.S. CBRS	<p>LTE bands: 1-5, 7, 8, 12-14, 17, 18-20, 25, 26, 28-30, 32, 38-43, 46, 48, 66, and 71.</p> <p>FDD LTE 600 MHz (band 71), 700 MHz (bands 12, 13, 14, 17, 28, and 29), 800 MHz (band 20), 850 MHz (bands 5, 18, 19, and 26), 900 MHz (band 8), 1500 MHz (band 32), 1700 MHz (bands 4 and 66), 1800 MHz (band 3), 1900 MHz (bands 2 and 25), 2100 MHz (band 1), 2300 MHz (band 30), 2600 MHz (band 7).</p> <p>TDD LTE 1900 MHz (band 39), 2300 MHz (band 40), 2500 MHz (band 41), 2600 MHz (band 38), 3500 MHz (bands 42 and 48), 3700 MHz (band 43), 5200 MHz (band 46).</p>
P-5GS6-GL	The 5G Sub-6 GHz Pluggable Interface Module offers 5G capability to the IoT Industrial Router family. The product ID for the pluggable module is P-5GS6-GL. The P-5GS6-GL uses the FN980 Telit modem.	Complete details can be found in the 5G Sub-6 GHz Pluggable Interface Module, on page 51 chapter.

GPS Technology Support

The IR1800 obtains GPS service through either the installed PIM modules, or from the dedicated IRM-GNSS-ADR module. Cisco supports GPS only with the initial IOS XE release 17.7.1. Please inquire with your sales representative for a roadmap of support for additional constellations.

Power Supply

IR1800 comes with an external DC power connector. The 4-pin power entry connector (receptacle) is mounted to the unit. The 4-pin power-entry mating connector (plug) is attached to the receptacle. It is removed during installation and used to connect to the DC power source, and then reattached to provide power to the unit.

For more information, see [Connecting the Router, on page 81](#).

Serial Ports

IR1800 supports up to two RJ-45 RS232 ports (depending on the model) that conform to EIA-561 standard. The pinout is shown in the table below.

One RS232 RJ45 serial port (S0) is intended as a DTE port supporting legacy RS232 equipment. The second serial port (S1) is intended as a DCE port, capable of both RS232 and RS485. RS485 can support full or half duplex.

The RJ45 pinouts are shown in the following figure and table:

Figure 5: Pinouts

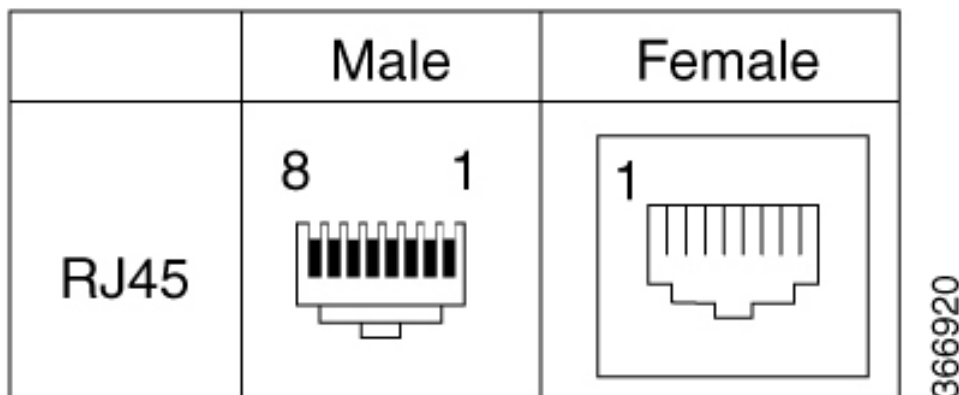

Table 8: Serial Port Characteristics

RS232					RS485 Full Duplex		RS485 Half Duplex	
Pin #	Signal Description	Abbr.	S0 (DTE)	S1 (DCE)	Signal	DIR	Signal	DIR
1	DCE ready. Used as DSR in Cisco IOS.	DSR/RI	Input	Output	TX-	Output	TX+	<->
2	Received Line Signal Detector	DCD	Input	Output	TX+	Output	TX-	<->
3	DTE Ready	DTR	Output	Input	RX-	Input	—	—
4	Signal Ground	COM	—	—	COM	—	COM	—
5	Received Data	RxD	Input	Output	—	—	—	—
6	Transmitted Data	TxD	Output	Input	RX+	Input	—	—
7	Clear To Send	CTS	Input	Output	—	—	—	—
8	Request To Send	RTS	Output	Input	—	—	—	—

USB Ports

A single USB port with a Type-A connector is present on the front panel. The port is USB 2.0 only, and can be used for USB sticks. We recommend that you do not use this in a hazardous location without mechanical constraint. All front panel USB ports are equipped with a screw hole for mechanical constraint. The USB port can provide a maximum current of 500mA at 5V.

A single USB port (micro-B) is provided for console access on the front panel. If your laptop or PC displays a message that you do not have the proper drivers to communicate with the IR1800, you can obtain them from your computer manufacturer.

**Caution**

If you are connecting to the USB port, note the following points:

- A connection to the USB port can only be made in a nonhazardous environment.
- The USB port cover must be reinstalled before the router can be deployed in a hazardous environment.



CHAPTER 3

Installing the Router

This chapter contains the following sections:

- [Overview, on page 23](#)
- [Safety Information, on page 23](#)
- [Equipment, Tools, and Connections, on page 24](#)
- [Installing the Router, on page 25](#)
- [Mounting on a Wall, Table, or Other Flat Surface, on page 25](#)
- [Installing a DIN Rail, on page 27](#)
- [Installing the Router Ground Connection, on page 35](#)

Overview

This section describes the equipment required, and the procedures to be performed for successfully installing the Cisco IR1800 Series router.

Safety Information



Caution

Do not install the router or power supplies next to a heat source of any kind, including heating vents.



Warning

Read the installation instructions before connecting the system to the power source. **Statement 1004**



Warning

Only trained and qualified personnel should be allowed to install, replace, or service this equipment. **Statement 1030**



Warning

Ultimate disposal of this product should be handled according to all national laws and regulations. **Statement 1040**



Warning Do not locate the antenna near overhead power lines or other electric light or power circuits, or where it can come into contact with such circuits. When installing the antenna, take extreme care not to come into contact with such circuits, because they may cause serious injury or death. For proper installation and grounding of the antenna, please refer to national and local codes (for example, U.S.:NFPA 70, National Electrical Code, Article 810, Canada: Canadian Electrical Code, Section 54). **Statement 1052**



Warning No user-serviceable parts inside. Do not open. **Statement 1073**



Warning This product is not intended to be directly connected to the Cable Distribution System. Additional regulatory compliance and legal requirements may apply for direct connection to the Cable Distribution System. This product may connect to the Cable Distribution System ONLY through a device that is approved for direct connection. **Statement 1078**



Note A minimum of -1 inch clearance is required on all sides of the product when mounting in either horizontal or vertical orientation. Stacking heat-dissipating objects on top of the router is not allowed. I/O side clearance is needed because it is required to access the cable connections. Clearance is required to attach, mount the DIN rail bracket, and Wall mount bracket.

Equipment, Tools, and Connections

This section describes the equipment, tools, and connections necessary for installing your Cisco IR1800.



Note No antennas are shipped with the IR1800 Series router.

Items Shipped with Your Router

Unpack the box and verify that all the items listed in the invoice are shipped with the Cisco IR1800.

The following items are shipped with your router:

- Pointer Card
- Grounding Lug Kit
- Power Connector

Additional Items

The following items are not shipped with the router, but are required for the installation:

- ESD-preventive cord and wrist strap.
- Wire crimper for chassis grounding.
- Wire for connecting the chassis to an earth ground.
- Ethernet cables for connecting to the Ethernet WAN and LAN ports.
- Ratcheting torque flathead screwdriver that exerts up to 15 in-lb (1.69 N-m) of pressure.
- A number-1 Phillips screwdriver.
- A number-2 Phillips screwdriver.

Installing the Router

This section describes how to install the IR1800 Series router. This router can be installed in the following ways:

- Table top
- Flat horizontal surface
- Mounted on a wall
- Using a DIN rail



Note For NEC-compliant grounding, use size 16awg (1.5mm²) or larger copper wire and a ring terminal with an inner diameter of 1/4 in. (6 to 7 mm).

Mounting on a Wall, Table, or Other Flat Surface

The Cisco IR1800 can be mounted in a vertical or horizontal orientation. It can be mounted using screws into studs in the wall, or using anchor mounting for hollow walls.



Tip When choosing a location for wall-mounting a router, consider cable limitations and wall structure, and consider suitable antenna location ahead of time.



Warning Read the wall-mounting instructions carefully before beginning installation. Failure to use the correct hardware or to follow the correct procedures could result in a hazardous situation to people and damage to the system.
Statement 378



Note A minimum of 1 inch clearance is required on all sides of the product when mounting in order to allow for proper air flow.

To mount a router on a wall or other flat surface, follow these steps:

Procedure

Step 1 Measure the area in which you will be mounting the device, using the following figure for guidance.

Note The following figure shows a portrait orientation, which is supported. However, the landscape orientation is the preferred mounting.

Figure 6: Mounting Hole Dimensions

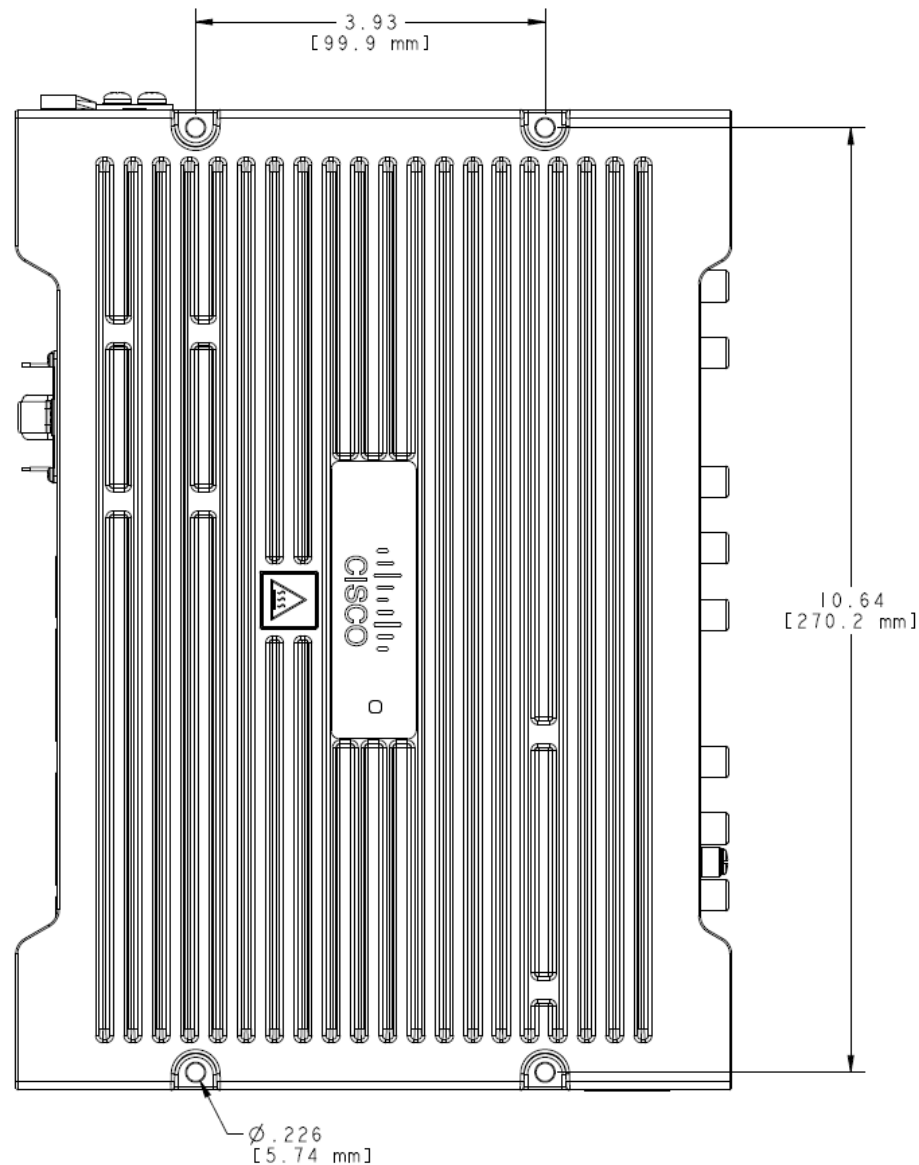

Note Mount the router in a proper wall structure to carry the weight of the device. Whenever possible, use a mounting location where the screws will go into wall studs.

- Step 2** Use four #10 screws when mounting the unit to the neighboring surface. The screws must be long enough to penetrate at least 1.0 inch (25.4 mm) into the supporting wood or metal wall stud. See the following figure for guidance.

Figure 7: Mounting Holes

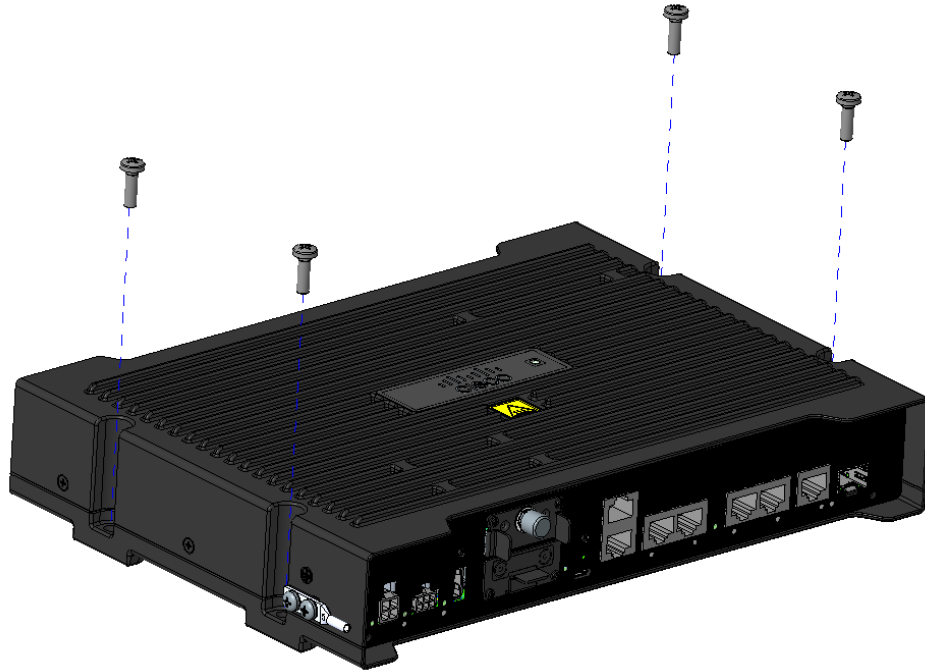

- Step 3** Route the cables so that they do not put a strain on the connectors or mounting hardware.

Note If you are mounting the device into a hollow wall, ensure that the wall material can support the router's weight. Use appropriate wall anchor mounts.

Installing a DIN Rail

The DIN rail kit must be ordered separately. The Cisco part number is IR1800-DINRAIL.



Note The DIN rail brackets come assembled in horizontal orientation. If your installation requires vertical orientation, disassemble the components and reassemble them.

Mounting the DIN Rail Bracket on the Router (Horizontal)

Procedure

- Step 1** Attach the DIN rail bracket to the back of the router, as shown in the following figure.

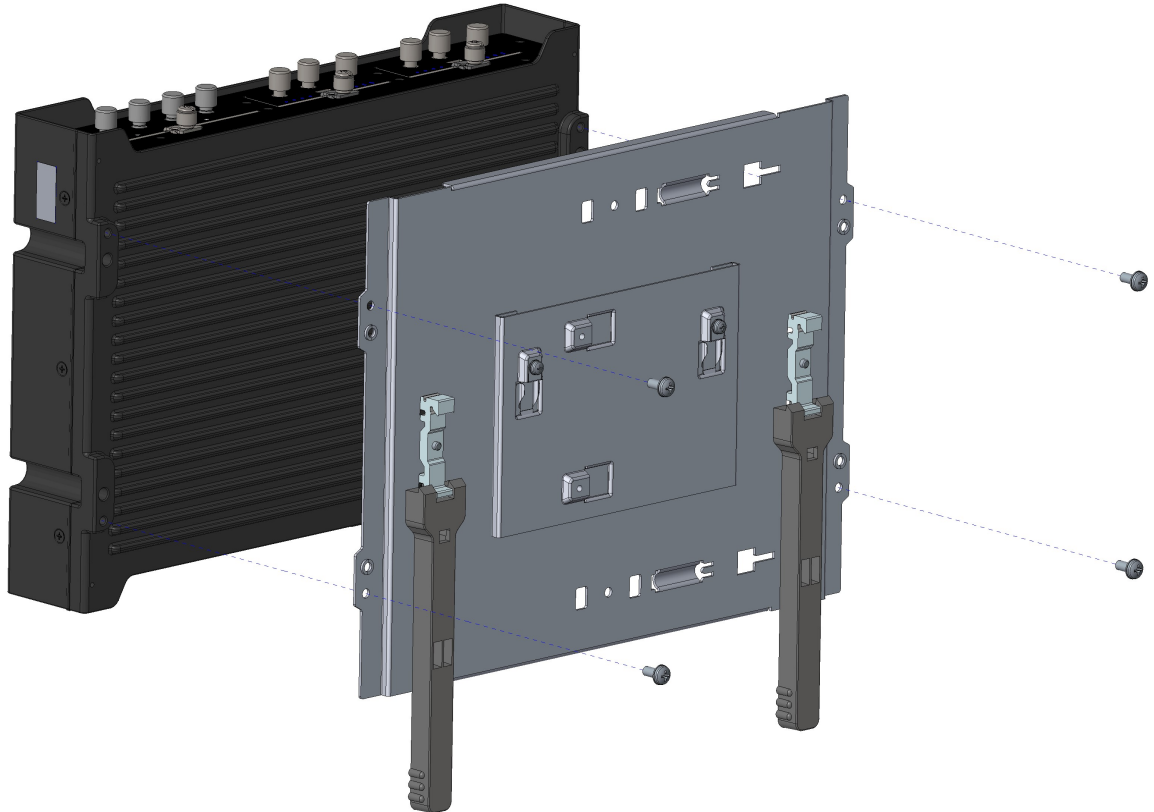

- Step 2** Attach the DIN mounting bracket to the router using the four 8-32 screws provided in the kit. Position the bracket over the four mounting holes and then insert the screws through the bracket into the chassis. Then use 14 in. lbs. of torque to screw the bracket onto the router.
- Step 3** After the bracket is attached to the router, it can be mounted onto the DIN rail.
-

Attaching the Bracket to the DIN Rail

To attach the Cisco IR1800 with the bracket to a DIN rail, see the following image and follow the steps provided.

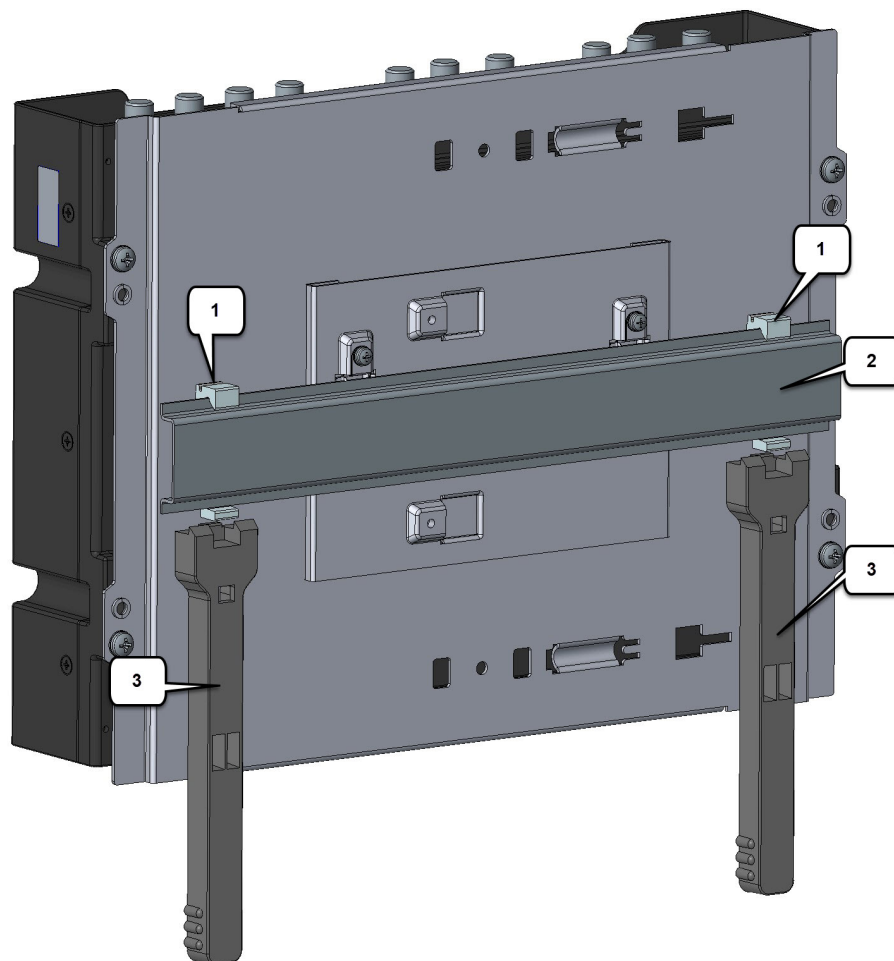

1	Clamps
2	Din Rail
3	Plastic Latches

Procedure

-
- Step 1** Position the router so that the clamps (1) on the DIN rail bracket hook onto the top edge of the DIN rail (2). The weight of the product can rest on the hook temporarily while the plastic latches are secured.
- Step 2** Pull down the plastic latches (3) at the same time and position the DIN rail bracket so that the top and bottom edges of the DIN rail are within the clamps.
- Step 3** Release the plastic latches after the DIN rail is firmly within the clamps to secure it. The router is now installed in the DIN rail.
- Step 4** To remove the router from the DIN rail, reverse the procedure.
-

Changing the Bracket Orientation

The DIN rail bracket arrives oriented in the horizontal mounting position. In order to mount your device in the vertical orientation, disassemble the bracket hardware and reassemble it in the new orientation.

Horizontal orientation is shown in the following figure:

Figure 8: Horizontal Orientation

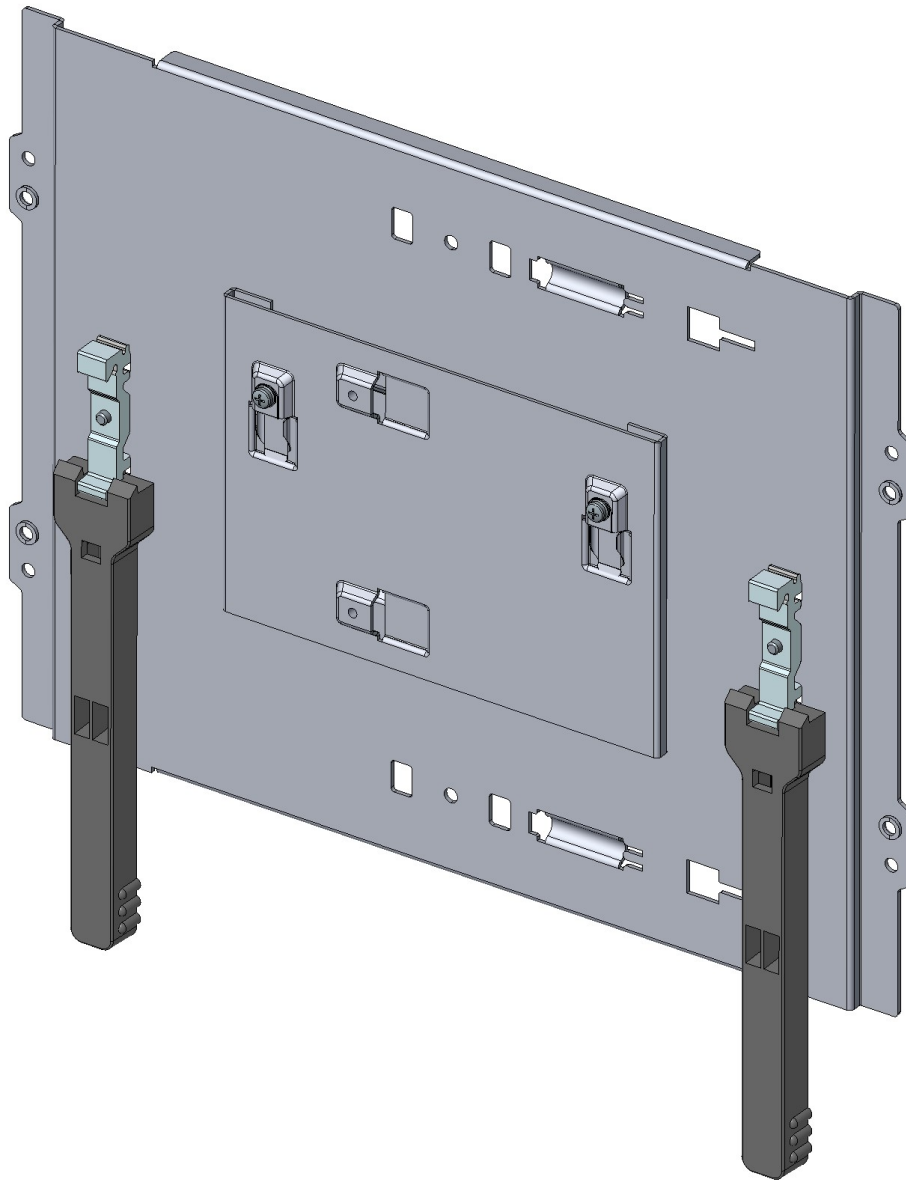

A vertical orientation is shown in the following figure:

Figure 9: Vertical Orientation

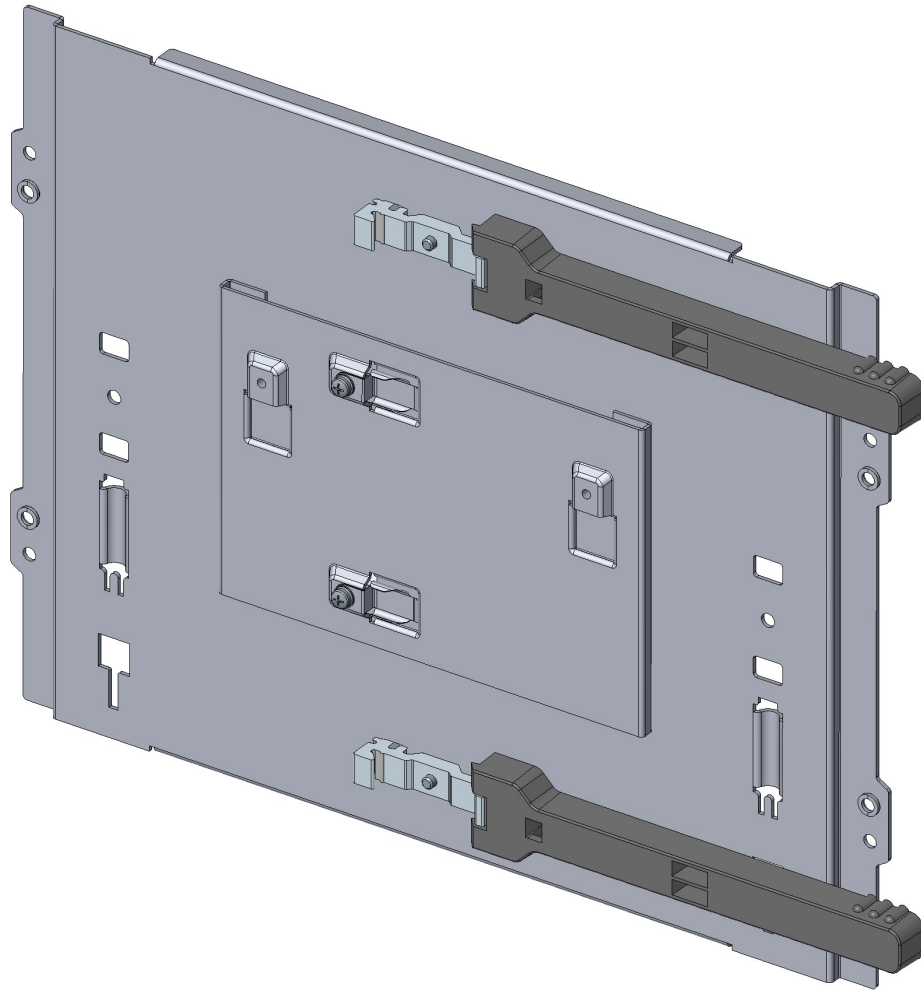

Bracket Disassembly

To disassemble the bracket hardware, see the following figure and follow the steps provided.

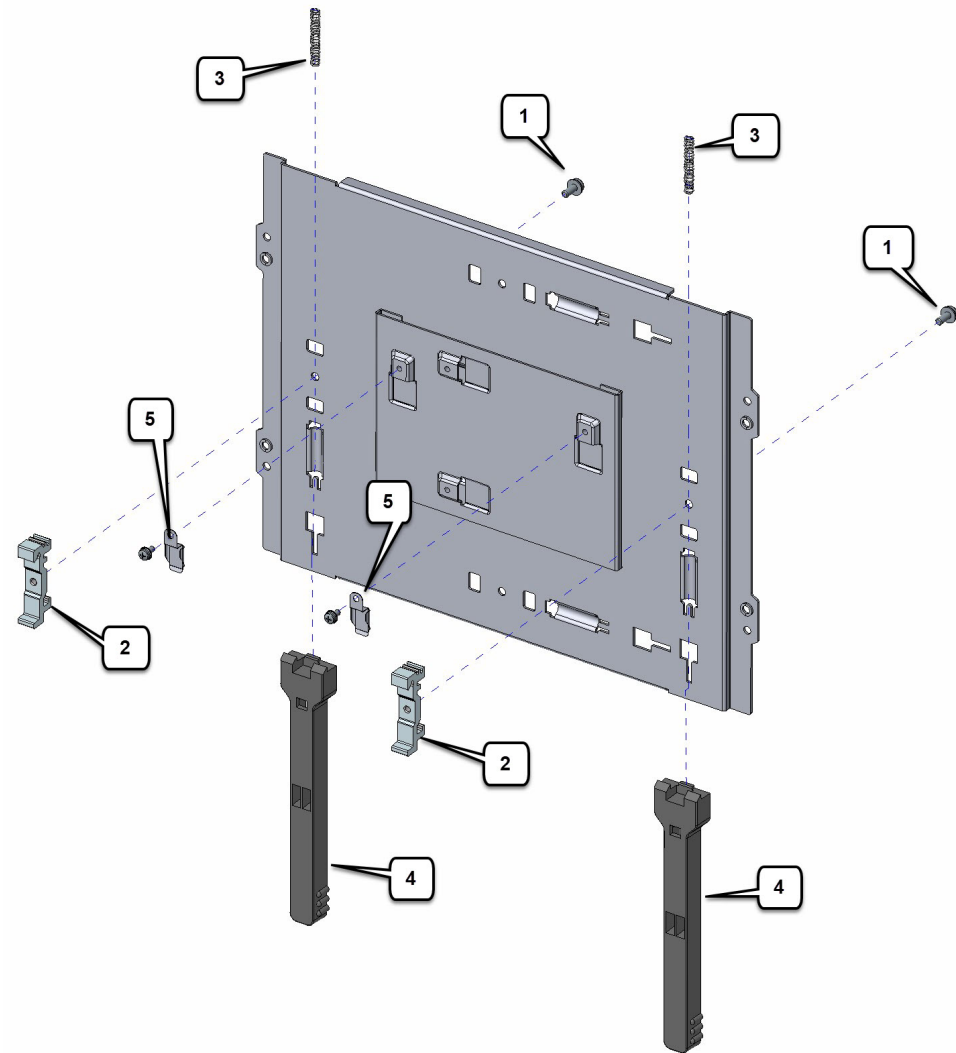

1	Screws
2	DIN rail clamps
3	Springs
4	Plastic latches
5	DIN rail clips

Procedure

- Step 1** Remove the two screws (1) that hold the two DIN rail clamps (2).
- Step 2** Slide the DIN rail clamps (2) away from the plastic latches (4) and remove them.
- Step 3** Slide the plastic latches (4) off the DIN rail plate, and remove the two springs (3).

Step 4 Remove the two DIN rail clips (5) from the mounting bracket.

Step 5 Note: Retain all the components for reuse when mounting with vertical orientation.

Bracket Reassembly

The following procedure shows how to reattach all of the bracket components to enable vertical orientation. See the following figure and follow the steps provided.

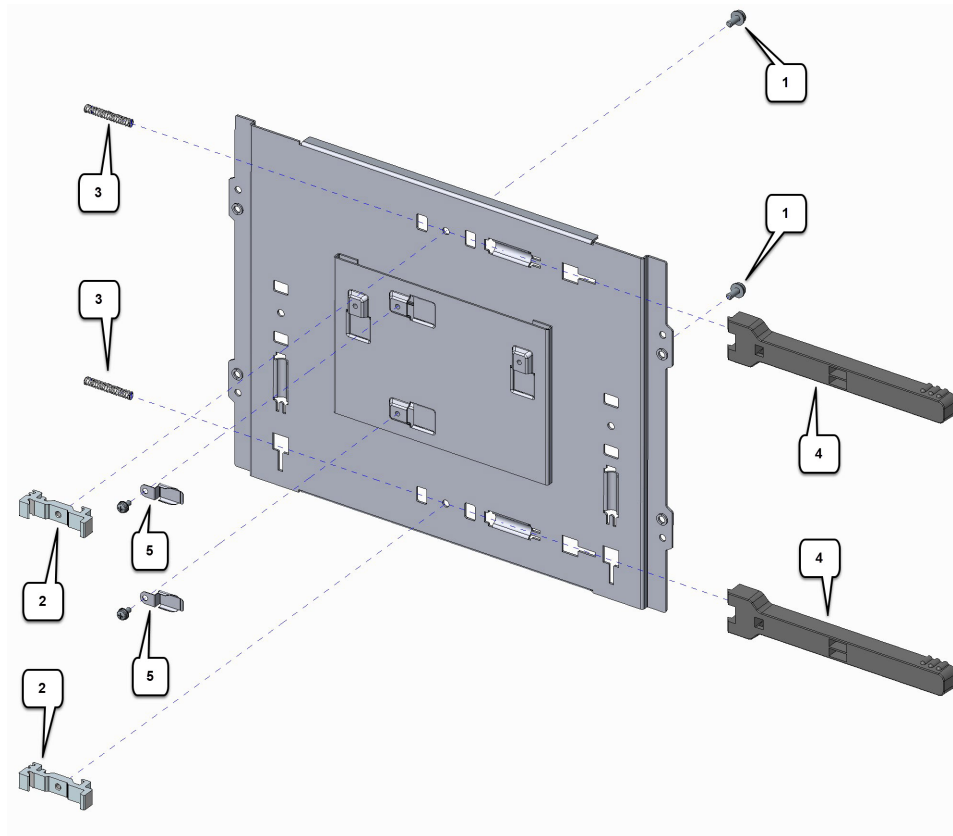

1	Screws
2	DIN rail clamps
3	Springs
4	Plastic latches
5	DIN rail clips

Procedure

Step 1 Slide the two springs (3) onto the thin tabs.

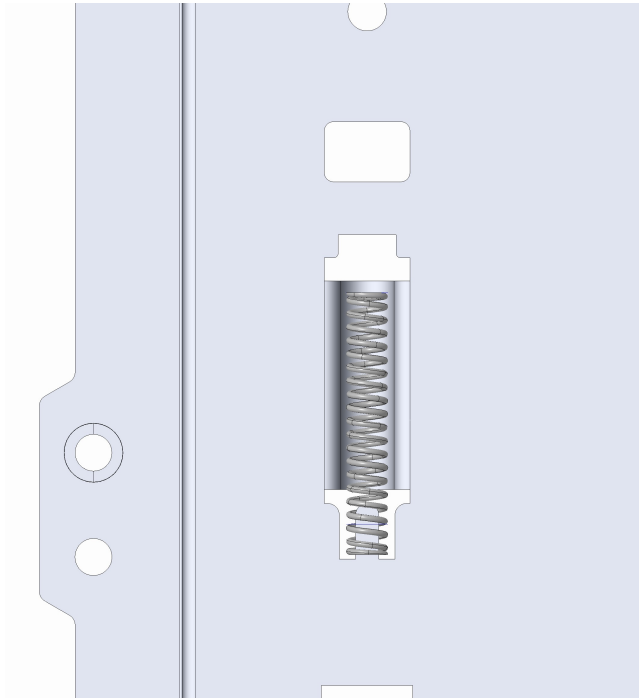

- Step 2** Slide the plastic latches (4) above the spring and backwards into the DIN rail plate opening.
- Step 3** Push each plastic latch (4) backwards and insert the DIN rail clamp (2) into the DIN rail plate opening. Fasten each clamp with screws (1), using 12 in-lbs of torque.
- Step 4** Reattach the two DIN rail clips (5) to the mounting bracket in a vertical orientation using 9 in-lbs of torque.
-

Mounting the DIN Rail Bracket on the Router (Vertical)

Procedure

- Step 1** Attach the DIN rail bracket to the back of the router, as shown in the following figure.

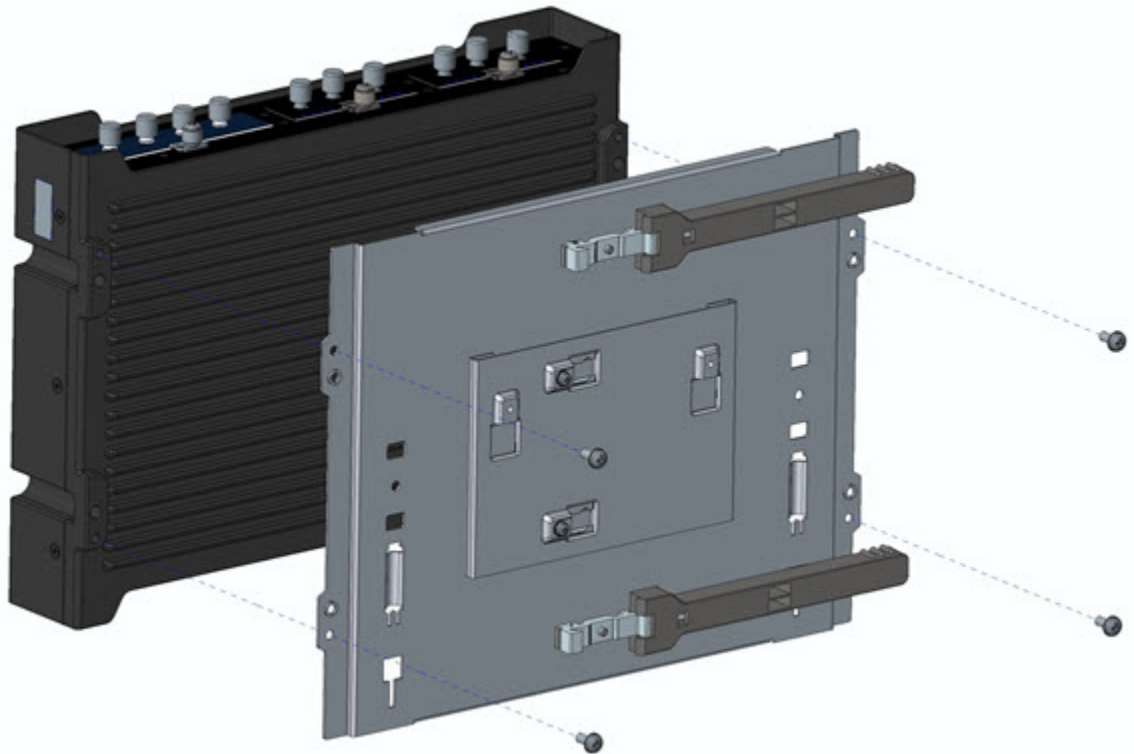

- Step 2** Attach the DIN mounting bracket to the router using the four 8-32 screws provided in the kit. Position the bracket over the four mounting holes and insert the screws through the bracket into the chassis. Then use 14 in. lbs. of torque to screw the bracket onto the router.
- Step 3** After the bracket is attached to the router, it can be mounted onto the DIN rail.

Installing the Router Ground Connection



Warning This equipment is intended to be grounded to comply with emission and immunity requirements. Ensure that the switch functional ground lug is connected to earth ground during normal use. **Statement 1064**



Warning This equipment must be grounded. Never defeat the ground conductor or operate the equipment in the absence of a suitably installed ground conductor. Contact the appropriate electrical inspection authority or an electrician if you are uncertain that suitable grounding is available. **Statement 1024**



Note Cable distribution system should be grounded (earthed) in accordance with ANSI/NFPA 70, the National Electrical Code (NEC), in particular Section 820.93, Grounding of Outer Conductive Shield of a Coaxial Cable.

For NEC-compliant grounding, use size 16 AWG (1.5 mm²) or larger copper wire and a ring terminal with an inner diameter of 1/4 in. (5 to 6 mm).

To install the ground connection, follow these steps:

Procedure

-
- Step 1** Locate the grounding lug that is in the accessory tray.
 - Step 2** Strip one end of the ground wire to 0.22 in. (5.56 mm).
 - Step 3** Crimp the ground wire to the grounding lug using the wire crimper.
 - Step 4** Attach the grounding lug (1) to the chassis using the screws provided. Tighten the screw to a torque of 8 to 10 inch-pound (0.9 to 1.1 newton meter). Refer to the following figure:

Figure 10: Chassis Ground Connection Points

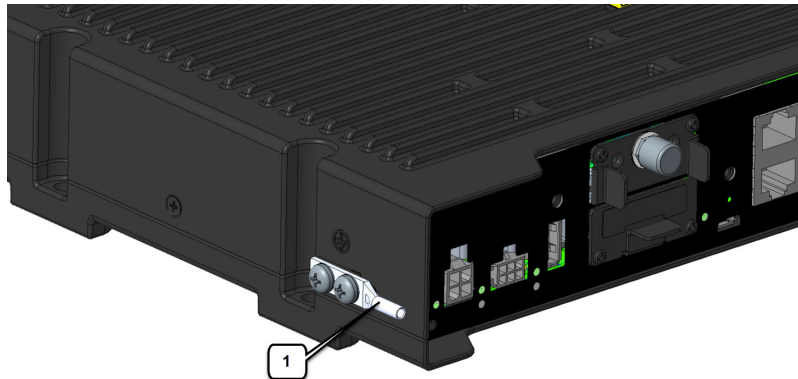

1	Grounding lug
---	---------------

- Step 5** Connect the other end of the ground wire to a known and reliable earth ground point at your site.
 - Step 6** If you are using this router in a vehicle, attach the ring terminal to the chassis using one of the screws provided, and the green or green and yellow striped wire. Connect the other end of the wire to the vehicle ground.
-

What to do next

After you install and properly ground the router, you can connect the power wiring, the LAN cables, and the cables for administrative access, as required for your installation.



CHAPTER 4

Antenna Selection and Installation

This chapter contains the following sections:

- [Introduction to Selecting Antennas](#), on page 37
- [Antenna Installation Best Practices](#), on page 37
- [Supported Antennas for the IR1800 Series Router](#), on page 39
- [Supported Extension Bases and Cables](#), on page 42

Introduction to Selecting Antennas



Note Before you install the Cisco IR1800 router on a table, wall, or DIN rail, install the antennas on the pluggable module. It is difficult to install the antennas after the router is installed.

This chapter contains information about selecting antennas for the IR1800 router.

The P-LTE-xx or P-LTEA-xx cellular modules have three RF SMA(f) connectors on the pluggable module. Two connectors, Main and Div (Diversity), are used to connect to the 4G/LTE modem. The third connector is used for GPS. The Diversity port is also referred to as an Aux connector.

The P-LTEAP18-GL module has four RF SMA(f) connectors. Two connectors are Primary (Main) supporting Uplink and Downlink, and two connectors are secondary supporting downlink MIMO.

The P-5GS6-GL module has five RF SMA(f) connectors, of which four support 4G LTE / 5G FR1 and one supports GPS.

Antenna Installation Best Practices

The optimal site location for antennas for 4G routers and cellular modules plays a significant role in determining the overall cellular link performance. Routers located at the farthest coverage points might have 10 to 50 percent of the bandwidth available compared to routers located closer to the cellular base station tower, away from obstructions, and with an unobstructed view of the cellular tower.

Because antennas transmit and receive radio signals over the air, the signal propagation and antenna performance may be adversely affected by the surrounding environment, including physical obstructions. Radio frequency (RF) interference may also occur between wireless systems located close to each other, especially if the

antennas of these systems are located close to each other. Interference may also occur when antennas are in close proximity to cable clutter or other sources of radio interference.

Follow these guidelines to ensure the best possible performance:

- When you use cellular antennas such as 3G UMTS, 4G/LTE, 4G/LTEA (LTE Advanced), and 5G NR FR1 with a modular router and a pluggable module, try to mount the antennas a certain distance away from the router. For example, in indoor deployments, an appropriate extension cable and antenna stand can be utilized. For outdoor installations, choose a suitable outdoor antenna, and mount it away from obstructions such that the antennas have a direct view of the cellular tower. The antenna's performance, and therefore that of the router, will not be optimal if mounted directly on a pluggable module. Primary reasons for possible degradation of performance include:
 - The router antenna's view of the cellular base station tower being obstructed by Ethernet cables, power cables, USB cables, and walls.
 - Possible coupling of digital noise from inside the router to the antenna when unshielded Ethernet cables are used.
- Keep antennas away from electrical and signal cable clutter. Metal conductors inside cables may block an antenna's view of the base station. Additionally, unshielded (and even shielded cables in some cases) may radiate signals that interfere with RF signal reception.
- We recommend that all the cellular antennas for the IR1800 are oriented vertically to ensure polarization match. While polarization of the signal may change because it is reflected from obstructions, when the view is unobstructed, vertical polarization is optimal.



Note When cellular FDD Band 5 is deployed with 3G WCDMA, 4G/LTE, or 4G/LTEA C/A, such as with P-LTE-US or P-LTEA-EA pluggable modules on certain carriers, ensure that both the Main and Aux cellular antennas are physically separated from the IR1800 chassis by a minimum of 5 feet (1.5 meters). This is applicable only to the P-LTE-xx receiver operation in Band 5 in a narrow 875-MHz frequency range. No significant effect has been observed on the P-LTE-xx cellular Band 5 receiver when antennas are separated from the chassis by more than 5 feet (1.5 meters). This information does not apply when the receive signal does not overlap 875 MHz, such as when operating on other bands, or other frequencies within FDD Band 5.

- For optimal MIMO performance, set the cellular Main and Aux antennas apart by at least 20 inches (50 cm). At the lowest LTE frequency of 617 MHz, 20 inches represents 1 wavelength. Spacing of half (or 0.5) wavelength or 10 inch (25 cm) results in good MIMO performance.
- Setting the Main and Aux LTE antennas less than 10 inches apart may result in significantly reduced MIMO performance.
- Placing the antennas too close to each other, for example 3 inches, results in the antennas significantly detuning from their original designed performance because of antenna coupling.
- Wherever possible, mount the IR1800 router with the pluggable LTE module and the antenna where the cellular base station or tower are within sight and without physical obstructions. Barriers along the line of sight between the router and the local base station degrades the wireless radio signals. Install the IR1800, pluggable modules, and antennas above floor level in office environments, or near the ceiling, for better performance because most obstructions tend to be near the floor level.

- The density of the materials used in a building's construction determines the number of walls the signal must pass through while still maintaining adequate coverage. Consider the following before choosing the location for installing the antenna:
 - Paper and vinyl walls have very little effect on signal penetration.
 - Solid and precast concrete walls limit signal penetration to one or two walls without degradation of coverage.
 - Concrete and wood block walls limit signal penetration to three or four walls.
 - A signal can penetrate five or six walls constructed of drywall or wood.
 - A thick metal wall or wire-mesh stucco wall causes signals to reflect back and causes poor penetration.
- Avoid mounting an antenna next to a column or vertical support. This might create a shadow zone and reduce the coverage area.
- Keep the antenna away from reflective metal objects such as heating and air-conditioning ducts, large ceiling trusses, building superstructures, and major power cabling runs. If necessary, use an extension cable to relocate the antenna away from these obstructions.

This radio transmitter [IC:2461A-WPWIFI6] has been approved by Innovation, Science and Economic Development Canada to operate with the antenna types listed in this guide, with the maximum permissible gain indicated. Antenna types that are not included in this list and have a gain greater than the maximum gain indicated for any type listed are strictly prohibited for use with the IR1800 Series router.

Le présent émetteur radio [IC:2461A-WPWIFI6] a été approuvé par Innovation, Sciences et Développement économique Canada pour fonctionner avec les types d'antenne énumérés ci-dessous et ayant un gain admissible maximal. Les types d'antenne non inclus dans cette liste, et dont le gain est supérieur au gain maximal indiqué pour tout type figurant sur la liste, sont strictement interdits pour l'exploitation de l'émetteur.

Supported Antennas for the IR1800 Series Router

The following tables list the antennas supported for IR800 Series router.



Note Wherever 4G LTE is mentioned in antenna RF port designations, the antennas will also support 5G NR in the same bands and ports, even though documentation may refer to the antenna as LTE. For details of which bands each antenna supports, please consult the detailed information for each antenna.

Pluggable Interface Modules

PIM	Module PID	Antenna Selection Single Port PID
LTE CAT4	P-LTE-GB P-LTE-NA P-LTE-VZ P-LTE-IN P-LTE-AU P-LTE-MNA	2 x LTE(4G) antennas LTE-ANTM2-SMA-D
LTE CAT6	P-LTEA-LA P-LTEA-EA	2 x LTE(4G) antennas LTE-ANTM2-SMA-D
LTE CAT18	P-LTEAP18-GL	4 x LTE(4G/5G) antennas LTE-ANTM2-SMA-D
4G LTE / 5G FR1	P-5GS6-GL	5G-ANTM-SMA-D

Wi Fi Modules

WIM	Module PID	Antenna Selection Single Port PID
Wi-Fi 6 (6th Gen/ .11ax)	WP-WIFI6-x	2x dual-band Wi-Fi (2.4/5 GHz) OR 4x single-band Wi-Fi (2x 2.4 GHz and 2x 5 GHz) W-ANTM2050D-RPSMA

Indoor Antennas

Antenna	PID	Antenna Specifications
Indoor LTE	LTE-ANTM2-SMA-D	Antenna Type: Dipole Frequency Band: 617-960 MHz 1400-1700 MHz 1710-2690 MHz 3400-3900 MHz 5150-6000 MHz Connector: SMA (m)

Antenna	PID	Antenna Specifications
Indoor 5G	5G-ANTM-SMA-D	Antenna Type: Dipole Frequency Band: 617-960 MHz 1400-1700 MHz 1710-2690 MHz 3400-3900 MHz 5150-6000 MHz Connector: SMA (m)
Indoor Wi-Fi	W-ANTM2050D-RPSMA	Antenna Type: Dipole Frequency Band: 2400-2500 MHz 5150-5850MHz Connector: RP SMA (m)

Outdoor Antennas

Antenna	PID	Antenna Specifications
Mast-Mounted Outdoor 4G, CBRS	ANT-4G-OMNI-OUT-N	Antenna Type: Dipole Frequency Band: 698-960 MHz 1695-2690 MHz 3400-3800 MHz Connector: N-type (f)
Mast-Mounted Outdoor 5G, FR1	ANT-5G-OMNI-OUT-N	Antenna Type: Dipole Frequency Band: 617-960 MHz 1448-1511 MHz 1695-2690 MHz 3300-4200 MHz 5150-7125 MHz Connector: N-type (f)

Outdoor and Transportation Antennas

Antenna	PID	Antenna Specifications	Notes
3-in-1 (LTE, GPS) Vehicle Mount/Fixed Infrastructure	4G-LTE-ANTM-O-3-B	Antenna Type: Multi-Element Connectors: 4G LTE (2x) TNC (m) GPS SMA (F)	Antennas will require proper TNC to SMA adapters. Location services supported only in areas with GPS coverage.
3-in-1 (LTE, GPS) Vehicle Mount/Fixed Infrastructure	ANT-3-4G2G1-O	Antenna Type: Multi-Element Connectors: 4G LTE (2x) TNC (m) GPS SMA (m)	Antennas will require proper TNC to SMA adapters. Location services supported only in areas with GPS coverage.
5-in-1 (LTE, Wi-Fi, and GPS) Vehicle Mount/Fixed Infrastructure	ANT-5-4G2WL2G1-O	Antenna Type: Multi-Element Connectors: LTE (2x) TNC (m) GPS SMA (m) Wi-Fi (2x) RP-TNC (m)	Antennas will require proper TNC to SMA adapters. Location services supported only in areas with GPS coverage.
7-in-1 (LTE, Wi-Fi, and GPS) Low-Profile Transportation Note Antenna is GNSS capable.	ANT-7-5G4WL2G1-O	Antenna Type: Multi-Element Connectors: LTE (4x) SMA (m) GPS (1x) SMA (m) Wi-Fi (2x) RP-SMA (m)	—
9-in-1 (LTE, Wi-Fi, and GPS) Low-Profile Transportation	5G-ANTM-O-4-B	Antenna Type: Multi-Element Connectors: LTE (4x) SMA (m) GPS (1x) SMA (m) Wi-Fi (4x) RP-SMA (m)	Requires ground disk (5G-ANTM-GD) with nonmetallic surface deployment.

Supported Extension Bases and Cables

Antenna Type	Antenna PID	Cable PID	Extension Base
Indoor (cellular)	LTE-ANTM2-SMA-D	CAB-L240-10-SM-TM CAB-L240-15-SM-TM CAB-L240-20-SM-TM	LTE-AE-MAG-SMA
Indoor (Wi-Fi)	W-ANTM2050D-RPSMA=	—	—
Outdoor (cellular)	ANT-4G-OMNI-OUT-N ANT-5G-OMNI-OUT-N	CAB-L240-10-SM-NM	—



CHAPTER 5

Pluggable Interface Modules

This chapter contains the following sections

- [Introduction to Installing Pluggable Interface Modules, on page 43](#)
- [Installing a PIM, on page 44](#)

Introduction to Installing Pluggable Interface Modules

This section describes the equipment and the procedures for successfully installing the Cisco Pluggable Interface Modules (PIM).

The highlights of the LTE PIM are:

- All cellular interfaces are supported through a PIM
- We recommend that you use Industrial Temp micro SIMs, 3FF size, that are rated from -40C to +105C
- To ensure a reliable contact to the SIM socket, gold-plated SIM cards must be used.

The following images show examples of a pluggable module. In this case, the LTE pluggable module.

Figure 11: LTE Pluggable Module (Front)

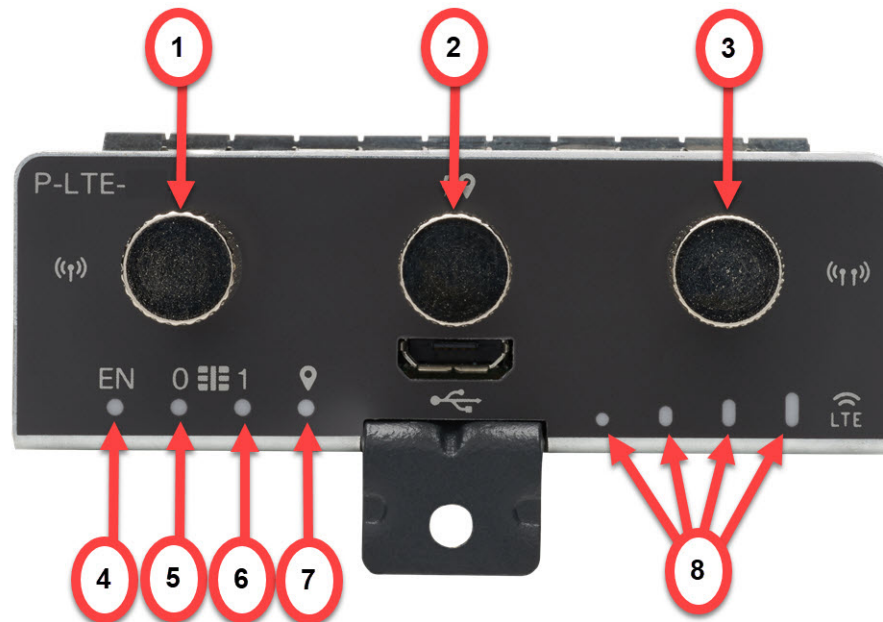

Item	Description
1	Cellular-Main SMA
2	GPS SMA
3	Cellular-Div SMA
4	Enable LED
5	SIM 0 LED
6	SIM 1 LED
7	GPS LED
8	RSSI LEDs

Installing a PIM

The modular cellular modem pluggable module's Remove and Replace options follow.

The IR1800 may have a blank plate covering the pluggable module slot. If it exists, remove it prior to installing the cellular modem module. The following steps show the LTE pluggable module, however, they apply to other modules as well.

Procedure

- Step 1** Remove the blank plate by unscrewing the latch lock screw(1) that holds the plate secure. Refer to the following graphic.

Figure 12: Latch Lock Screw



1	Latch lock screw
---	------------------

- Step 2** Slide the blank plate out of the device.
- Step 3** Prepare the cellular modem module by inserting the micro sims that are applicable for your modems into the device. Remove the screw (1) holding the access plate which covers the SIM slots. The access plate is located on the side of the module, as shown in the following figures.

Figure 13: SIM Access Plate

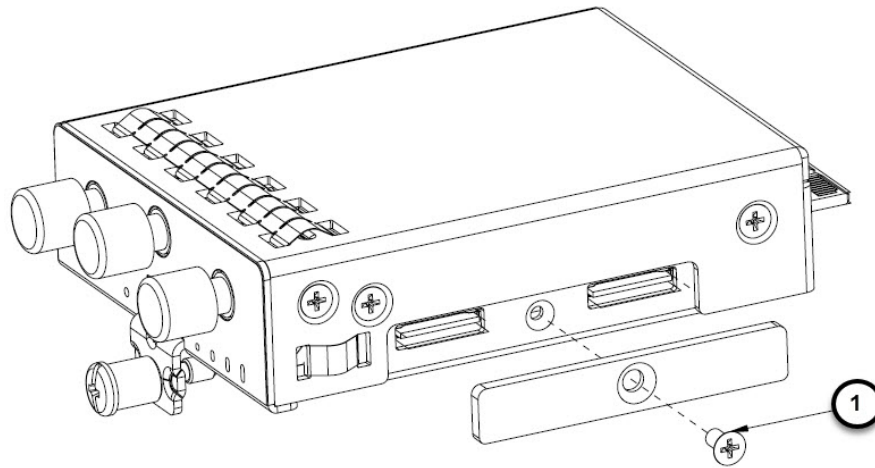

1	Access plate screw
---	--------------------

Step 4 Install your SIMs as shown in the following figure. Make note of the slot number and SIM orientation.

Figure 14: SIM Installation

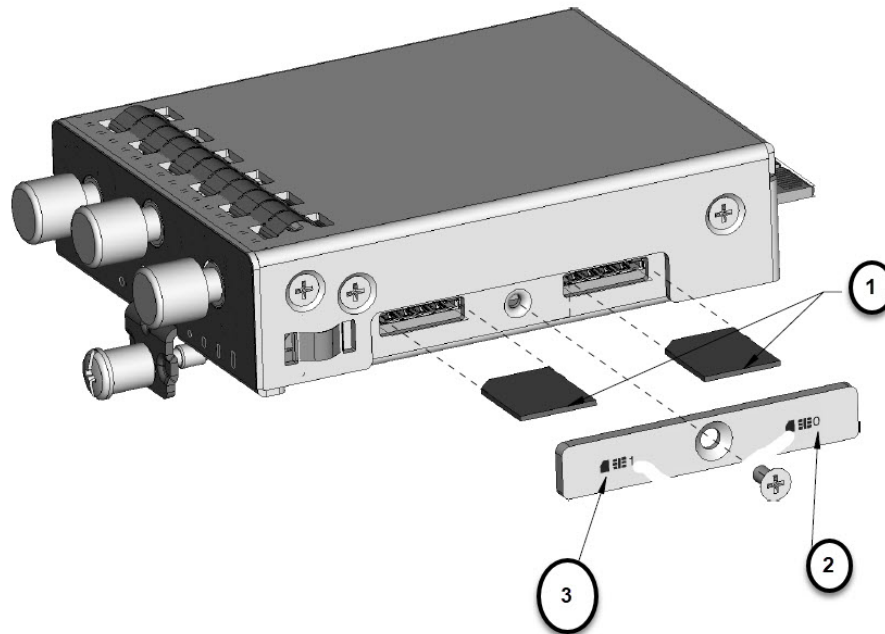

1	Micro SIMs
2	SIM 0

3	SIM 1
---	-------

Step 5 Push each SIM until it clicks into place. After the SIMs are installed, reattach the access plate that you previously removed earlier using a screwdriver. Torque to 2.8 to 3.8 inch-lbs (0.9-1.1 Newton meter).

Note Ensure that the cover is properly aligned with the screw hole.

Step 6 If your pluggable module is the type that has a USB port, make sure that the USB cover is properly installed. Place the USB cover (1) with the plug indentation against the USB port (2), as shown in the following figure. The half circle of the USB cover fits behind the latch lock screw.

Figure 15: USB Port Cover Installation



1	USB cover
2	USB port

Step 7 Tighten the latch lock screw to a torque of 2.8 to 3.8 inch-lbs (0.3 to 0.4 Newton meter). The following figure shows a finished USB cover installation.

Figure 16: Completed USB Cover Installation

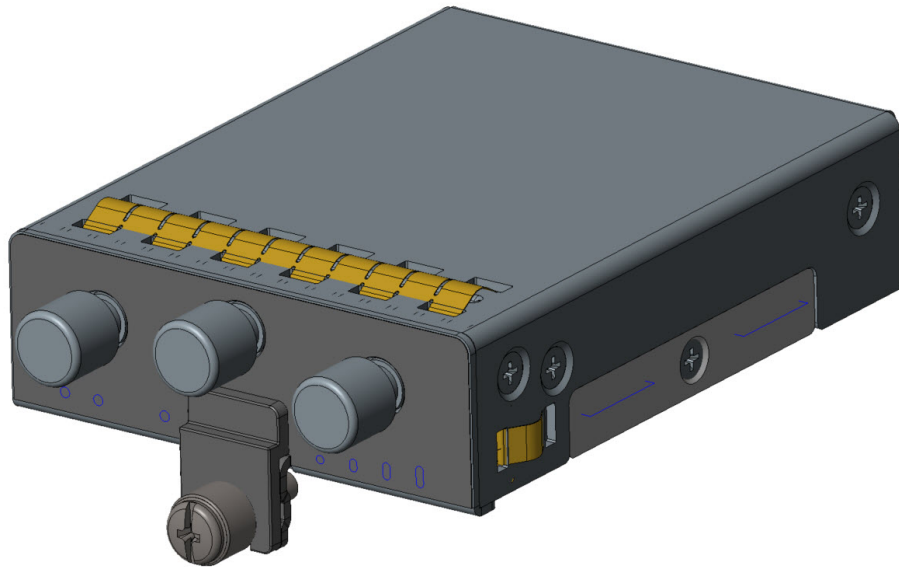

Step 8 Slide the pluggable module into the device, as shown in the following figure. The latch lock screw (1) aligns with the screw hole (2) on the face of the device. Push the pluggable module all the way into the device until you feel it seat, and then torque the latch lock screw 8-10 inch-pound (0.9 to 1.1 Newton meter).

Figure 17: Pluggable Module Insertion

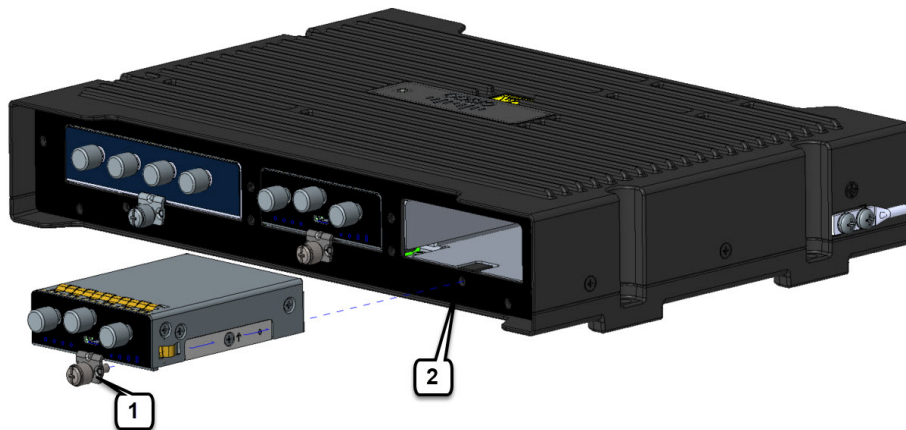

1	Latch lock screw
2	Screw hole

Step 9 Attach your antenna cables to the ports on the pluggable module. There are different instructions for each antenna type. So be sure to consult the corresponding antenna documentation for proper orientation and torque to install them.

Note If no antenna cables are being installed on a port, make sure the caps are installed on the unused connector.



CHAPTER 6

5G Sub-6 GHz Pluggable Interface Module

This chapter contains the following sections:

- [5G Sub-6 GHz Support on IoT Routing, on page 51](#)
- [5G Pluggable Interface Module Overview, on page 52](#)
- [LED Behaviors, on page 53](#)
- [RF Band and Port Mapping for the P-5GS6-GL Antenna, on page 54](#)
- [Thermal Mitigation, on page 55](#)
- [Attaching an Antenna, on page 57](#)

5G Sub-6 GHz Support on IoT Routing

The 5G Sub-6 GHz Pluggable Interface Module offers 5G capability to the IoT Industrial Router family. The product ID for the pluggable module is P-5GS6-GL. The P-5GS6-GL uses the FN980 Telit modem.



Note IOS XE release 17.7.1 is the first software release to provide support for the P-5GS6-GL.

Features and Limitations

The following features and limitations apply across all IoT routing platforms unless specifically mentioned:

- IoT routing platforms support a maximum of two pluggable modules, with a combination of 5G and 4G PIMs.
- The pluggable module can be started or stopped through the CLI under exec mode. Also, it can be configured to power off the module to reduce power consumption as needed.
- The capability to disable FDD Band 30 for vehicular applications is available.

The following are product specific:

- On the IR1101, when plugged into the base, the module is accessible via Cellular 0/1/0, 0/1/1.
- On the IR1101, the module is not supported on the expansion module.
- On the IR1800, the cellular modems are accessible via Cellular 0/4/0, 0/4/1, 0/5/0, 0/5/1.

5G Pluggable Interface Module Overview

The following figure shows the P-5GS6-GL pluggable module:

Figure 18: 5G Pluggable Interface Module - P-5GS6-GL

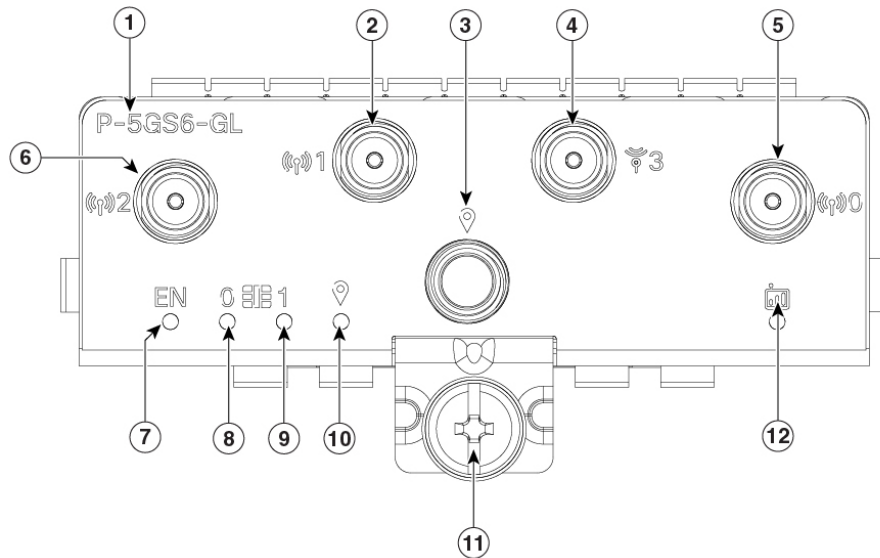

357258

1	PID
2	Antenna 1 (SMA)
3	GPS (SMA)
4	Antenna 3 (SMA)
5	Antenna 0 (SMA)
6	Antenna 2 (SMA)
7	Enable LED
8	SIM 0 LED
9	SIM 1 LED
10	GPS LED
11	M3.5 thumb-screw
12	Service LED

LED Behaviors

The following table lists the LED indicators and their behavior. The LEDs provide a visual indication of the status and the currently selected services.

LED Indicators:

LED	Color	Function
EN	Green, Yellow	Enable LED <ul style="list-style-type: none"> • Pluggable enable LED • Off: System power is off • Yellow: Module power is not functioning correctly • Green: Module power is on
SIM0	Green, Yellow	SIM0 LED/Activity <ul style="list-style-type: none"> • SIM0 LED status and WWAN activity • Off: SIM0 is not installed • Yellow: SIM0 is installed, but not active • Green: SIM0 installed and active • Green Flash: LTE data activity
SIM1	Green, Yellow	SIM1 LED/Activity <ul style="list-style-type: none"> • SIM1 LED status and WWAN activity • Off: SIM1 is not installed • Yellow: SIM1 is installed, but not active • Green: SIM1 installed and active • Green Flash: LTE data activity
GPS	Green, Yellow	GPS LED <ul style="list-style-type: none"> • Off: GPS not configured • Yellow: Software defined • Green: GPS configured • Green Flash: GPS acquiring (flashing done by SW)
Service	Green, Yellow, Blue	Service Indication LED <ul style="list-style-type: none"> • Yellow: 3G

LED	Color	Function
		<ul style="list-style-type: none"> • Green: 4G LTE • Blue: 5G

RF Band and Port Mapping for the P-5GS6-GL Antenna

The following table lists the RF band mapping for antenna ports.

RF Band Mapping for Antenna Ports:

Antenna Port	Technology	TX	RX
ANT 0	3G WCDMA	B1, B2, B3, B4, B5, B6, B8, B9, B19	B1, B2, B3, B4, B5, B6, B8, B9, B19
	4G LTE	B1, B2, B3, B4, B5, B7, B8, B12, B13, B14, B17, B18, B19, B20, B25, B26, B28, B30, B34, B38, B39, B40, B41, B66, B71	B1, B2, B3, B4, B5, B7, B8, B12, B13, B14, B17, B18, B19, B20, B25, B26, B28, B29, B30, B32, B34, B38, B39, B40, B41, B42, B43, B46, B48, B66, B71
	5G NR FR1	n1, n2, n3, n5, n7, n8, n12, n20, n28, n38, n40, n41, n66, n71	n1, n2, n3, n5, n7, n8, n12, n20, n25, n28, n38, n40, n41, n48, n66, n71, n77, n78, n79
ANT 1	3G WCDMA	—	B1, B2, B3, B4, B5, B6, B8, B9, B19
	4G LTE	B5, B20, B42, B43, B48, B71	B1, B2, B3, B4, B5, B7, B8, B12, B13, B14, B17, B18, B19, B20, B25, B26, B28, B29, B30, B32, B34, B38, B39, B40, B41, B42, B43, B46, B48, B66, B71
	5G NR FR1	n5, n48, n77, n78, n79	n1, n2, n3, n5, n7, n8, n12, n20, n25, n28, n38, n40, n41, n48, n66, n71, n77, n78, n79
ANT 2	3G WCDMA	—	—
	4G LTE	B1, B2, B3, B4, B7, B41, B66	B1, B2, B3, B4, B7, B25, B30, B32, B34, B38, B39, B40, B41, B42, B43, B46, B48, B66
	5G NR FR1	n1, n2, n3, n7, n25, n41, n66, n77, n78, n79	n1, n2, n3, n7, n25, n38, n40, n41, n48, n66, n77, n78, n79

Antenna Port	Technology	TX	RX
ANT 3	3G WCDMA	—	—
	4G LTE	—	B1, B2, B3, B4, B7, B25, B30, B32, B34, B38, B39, B40, B41, B42, B43, B46, B48, B66
	5G NR FR1	—	n1, n2, n3, n7, n25, n38, n40, n41, n48, n66, n77, n78, n79

Port Mappings for 5G-ANTM-0-4-B on the P-5GS6-GL PIM

The following table lists the port mappings using the 5G-ANTM-0-4-B antenna as an example, mapping to the ports on the P-5GS6-GL pluggable module.

5G-ANTM-0-4-B	P-5GS6-GL
MAIN 0 (LTE1)	ANT 0
MAIN 1 (LTE3)	ANT 1
DIV 0 (LTE2)	ANT 2
DIV 1 (LTE4)	ANT 3
GNSS	GPS

The following link contains the antenna specifications and installation instructions for 5G NR (5G-ANTM-0-4-B):

https://www.cisco.com/c/en/us/td/docs/routers/connectedgrid/antennas/installing-combined/b-cisco-industrial-routers-and-industrial-wireless-access-points-antenna-guide/m-5g-antm-04b.html#Cisco_Generic_Topic.dita_e780a6fe-fa46-4a00-bd9d-1c6a98b7bcb9

Thermal Mitigation

The following tables provide a description of thermal mitigation levels and throughput performance across all IoT industrial routers.

This applies to both the 4G LTE and 5G NR FR1 operation of the P-5GS6-GL.

Table 9: Thermal Mitigation Levels

Level	Description
Level 0	Normal mode, no thermal throttling.
Level 1	Uplink throttling, via reduced UL TX duty cycle.

Level	Description
Level 2	May include the following: <ul style="list-style-type: none"> • DL throughput capability reduction, such as 4 RX > 2 RX paths. • Drop Secondary Cells (SCells) all, or one by one. • 5G NR > 4G LTE fall back. • MTPL backoff or reduced TX power. • Reduced UL communication range.
Level 3	Limited service. Note Limited service typically means emergency calls only. The P-5GS6-GL does not support emergency call mode, therefore limited service means “no service” for the P-5GS6-GL .
Thermal Shutdown	This occurs after Level 3.



Note Cisco does not recommend operation deep into level 2 as this may affect communication range via MTPL backoff.

Table 10: Thermal Mitigation Table - IR1101

Hardware	Maximum Ambient Temperature (C/F)	Airflow (LFM)	Throughput Performance
IR1101 plus 2x IRM-1100 Single P-5GS6-GL	60°/140°	0	Normal, Level 0
	65°/149°	40	Throttled, Level 2
	70°/158°	40	Throttled, Level 3
	70°/158°	200	Throttled, Level 1
	75°/167°	200	Throttled, Level 2

Table 11: Thermal Mitigation Table - IR1835

Hardware	Maximum Ambient Temperature (C/F)	Airflow (LFM)	Throughput Performance
IR1835 plus WP-WIFI6 Dual P-5GS6-GL	60°/140°	0	Normal, Level 0
	65°/149°	40	Normal, Level 0
	70°/158°	40	Throttled, Level 1
	70°/158°	200	Normal, Level 0
	75°/167°	200	Throttled, Level 1

Attaching an Antenna

To attach the antenna in the Pluggable Interface Module, perform the below steps:

Figure 19: Attaching 5G NR Antenna (5G-ANTM-04-B) to P-5GS6-GL PIM

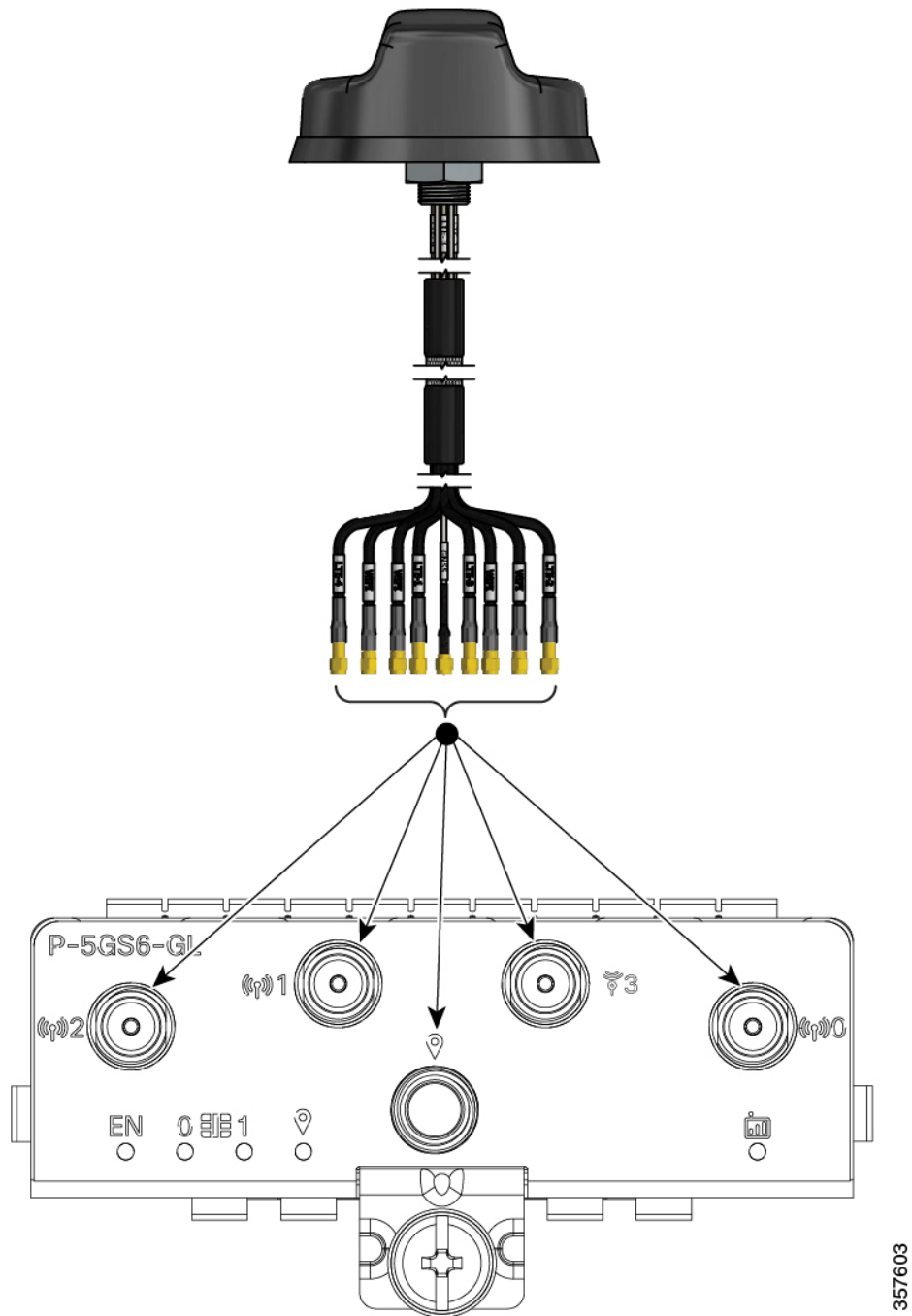

1. Attach each SMA cable to the ports as indicated in the table mappings.
2. Ensure that you tighten and secure each SMA cable into the SMA connector on the PIM.

357603



CHAPTER 7

Cisco Wi-Fi Interface Module (WIM)

This chapter contains the following sections:

- [Overview, on page 59](#)
- [Installation, on page 61](#)
- [Transmit Power and Receive Sensitivity, on page 63](#)
- [Thermal Mitigation, on page 66](#)

Overview

This overview describes the Cisco Wide Pluggable Form Factor WiFi6 AP Module for Industrial Routers. The PID is WP-WIFI6-x.

The Cisco Wi-Fi Interface Module will be referred to as the WIM from this point forward.

Highlights of the WIM are:

- Pluggable 802.11ax module for IoT Routers
- WiFi-6 (802.11ax), 2x2 MIMO with 2 spatial streams
- Supports WGB Mode
- EWC Controller Support
- Field Replaceable Unit (FRU), however does not support OIR (Online Insertion and Removal)
- Versatile RF coverage with external RP-SMA antenna connectors
- Flexible Antenna Port feature support

The following graphic illustrates the front panel of the WIM.

Figure 20: WIM Front Panel

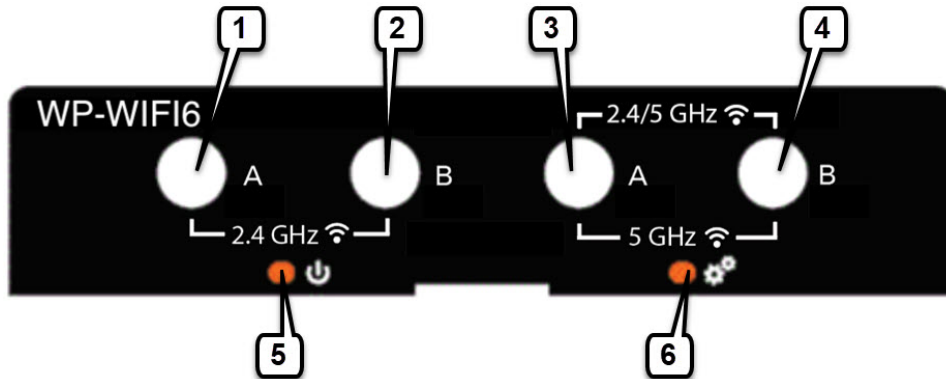

Item	Description
1	WLAN ANT 0 Disabled when the flexible antenna ports are set to dual-band mode (Default). 2.4 GHz when the flexible antenna ports are set to single-band mode.
2	WLAN ANT 1 Disabled when the flexible antenna ports are set to dual-band mode (Default). 2.4 GHz when the flexible antenna ports are set to single-band mode.
3	WLAN ANT 0 2.4/5 GHz when the flexible antenna ports are set to dual-band mode (Default). 5 GHz only when the flexible antenna ports are set to single-band mode.
4	WLAN ANT 1 2.4/5 GHz when the flexible antenna ports are set to dual-band mode (Default). 5 GHz only when the flexible antenna ports are set to single-band mode.
5	Enable LED
6	Wi-Fi LED

Table 12: Enable LED

LED Status	Description
Off	No Power
Yellow	Power is on, module is not yet functional
Green	Module is fully functional

Table 13: Wi-Fi LED

LED Status	Status Type	Description
Solid Green	Association Status	Normal operating condition, but no wireless client associated.
Solid Blue	Association Status	Normal operating condition, at least one wireless client associated.
Solid Green	Boot Loader Status	Executing Boot Loader
Flashing Green	Boot Loader Status	Boot Loader Error, signing verification error.
Flashing Blue	Operating Status	Software upgrade in progress.
Alternate between Green and Red	Operating Status	Discovery/Join process is in progress.
Cycle through Red-Off-Green-Off-Blue-Off	Access Point operating system error	General warning; insufficient inline power.

Installation

The Cisco Wi-Fi Interface Module remove and replace options are shown in the following steps.

The Router may have a blank plate covering the Wi-Fi Interface Module slot. This will need to be removed prior to installing the Wi-Fi Interface Module. The following example shows the Wi-Fi Interface Module.

Procedure

-
- Step 1** Remove the blank plate by unscrewing the latch lock screw(1) that holds the plate secure. Refer to the following graphic.

Figure 21: Latch Lock Screw



Step 2 Slide the blank plate out of the device.

Step 3 Slide the Wi-Fi Module into the device as shown in the following graphic. The latch lock screw (1) aligns with the screw hole (2) on the face of the device. Push the Wi-Fi Module all the way into the device until you feel it seat, and then torque the latch lock screw 8-10 inch-pound (0.9 to 1.1 newton meter).

Figure 22: Wi-Fi Module

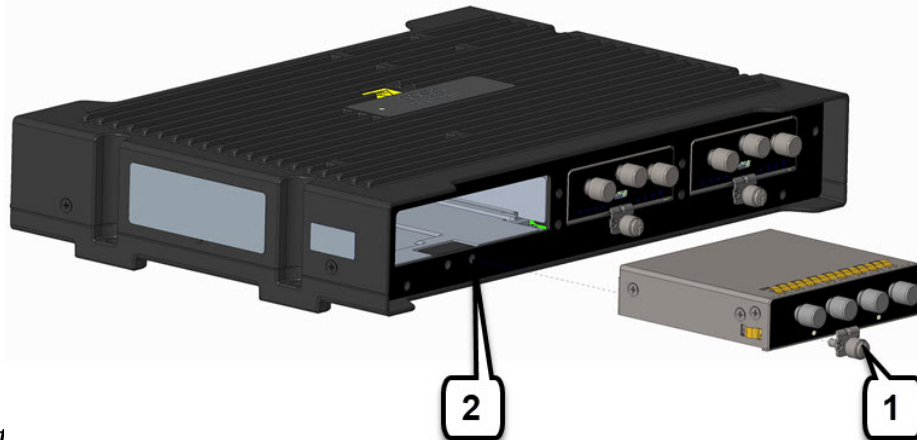

Insert

- Step 4** Attach your antennas to the ports on the Wi-Fi module. There are different instructions for each antenna type, be sure to consult the antenna documentation for proper orientation and torque to install them.
- Step 5** If no antennas are being installed on a port, make sure the caps are installed on the connector.

Transmit Power and Receive Sensitivity

The following series of tables provide details for the transmit power and receive sensitivity.

Table 14: 802.11/11b

			5 GHz Radio		2.4 GHz Radio	
	Spatial Streams	Number of Active Antennas	Total TX power (dBm)	RX sensitivity (dBm)	Total TX power (dBm)	RX sensitivity (dBm)
1 Mbps	1	2	—	—	23	-97
11 Mbps	1	2	—	—	23	-88

Table 15: 802.11a/g

			5 GHz Radio		2.4 GHz Radio	
	Spatial Streams	Number of Active Antennas	Total TX power (dBm)	RX sensitivity (dBm)	Total TX power (dBm)	RX sensitivity (dBm)
6 Mbps	1	2	20	-93	21	-92
24 Mbps	1	2	20	-86	21	-86
54 Mbps	1	2	19	-77	21	-78

Table 16: 802.11n HT20

			5 GHz Radio		2.4 GHz Radio	
	Spatial Streams	Number of Active Antennas	Total TX power (dBm)	RX sensitivity (dBm)	Total TX power (dBm)	RX sensitivity (dBm)
MCS0	1	2	20	-93	21	-92
MCS15	2	2	19	-71	21	-73

Table 17: 802.11n HT40

			5 GHz Radio		2.4 GHz Radio	
	Spatial Streams	Number of Active Antennas	Total TX power (dBm)	RX sensitivity (dBm)	Total TX power (dBm)	RX sensitivity (dBm)
MCS0	1	2	20	-90	—	—
MCS15	2	2	19	-68	—	—

Table 18: 802.11ac VHT20

			5 GHz Radio		2.4 GHz Radio	
	Spatial Streams	Number of Active Antennas	Total TX power (dBm)	RX sensitivity (dBm)	Total TX power (dBm)	RX sensitivity (dBm)
MCS0	1	2	20	-93	—	—
MCS8	1	2	18	-70	—	—
MCS0	2	2	20	-90	—	—
MCS8	2	2	18	-67	—	—
MCS9	2	2	—	—	—	—

Table 19: 802.11ac VHT40

			5 GHz Radio		2.4 GHz Radio	
	Spatial Streams	Number of Active Antennas	Total TX power (dBm)	RX sensitivity (dBm)	Total TX power (dBm)	RX sensitivity (dBm)
MCS0	1	2	20	-90	—	—
MCS9	1	2	17	-66	—	—
MCS0	2	2	20	-87	—	—
MCS9	2	2	17	63	—	—

Table 20: 802.11ac VHT80

			5 GHz Radio		2.4 GHz Radio	
	Spatial Streams	Number of Active Antennas	Total TX power (dBm)	RX sensitivity (dBm)	Total TX power (dBm)	RX sensitivity (dBm)
MCS0	1	2	20	-87	—	—
MCS9	1	2	16	-63	—	—
MCS0	2	2	20	-84	—	—
MCS9	2	2	16	60	—	—

Table 21: 802.11ax HE20

			5 GHz Radio		2.4 GHz Radio	
	Spatial Streams	Number of Active Antennas	Total TX power (dBm)	RX sensitivity (dBm)	Total TX power (dBm)	RX sensitivity (dBm)
MCS0	1	2	20	-94	20	-92
MCS11	1	2	16	-63	15	-66
MCS0	2	2	20	-92	20	-91
MCS11	2	2	16	60	15	62

Table 22: 802.11ax HE40

			5 GHz Radio		2.4 GHz Radio	
	Spatial Streams	Number of Active Antennas	Total TX power (dBm)	RX sensitivity (dBm)	Total TX power (dBm)	RX sensitivity (dBm)
MCS0	1	2	20	-91	—	—
MCS11	1	2	16	-60	—	—
MCS0	2	2	20	-88	—	—
MCS11	2	2	16	-57	—	—

Table 23: 802.11ax HE80

			5 GHz Radio		2.4 GHz Radio	
	Spatial Streams	Number of Active Antennas	Total TX power (dBm)	RX sensitivity (dBm)	Total TX power (dBm)	RX sensitivity (dBm)
MCS0	1	2	20	-88	—	—

			5 GHz Radio		2.4 GHz Radio	
	Spatial Streams	Number of Active Antennas	Total TX power (dBm)	RX sensitivity (dBm)	Total TX power (dBm)	RX sensitivity (dBm)
MCS11	1	2	16	-57	—	—
MCS0	2	2	20	-85	—	—
MCS11	2	2	16	-54	—	—

Thermal Mitigation

The following table provides a description of thermal mitigation levels and throughput performance.

This applies to the IR1835 with dual P-LTEAP18-GL pluggable modules and the WP-WIFI6 pluggable module.

Table 24: Thermal Mitigation Table - IR1835

Hardware	Maximum Ambient Temperature (C/F)	Airflow (LFM)	Throughput Performance
IR1835 plus WP-WIFI6 Dual P-5GS6-GL	60°/140°	0	Throttled, 1x1 SISO
	65°/149°	40	Throttled, 1x1 SISO
	70°/158°	200	Throttled, 1x1 SISO

The WP-WIFI6 pluggable will experience normal operation up to 55°C/131°F. Under normal conditions both 2.4 and 5 GHz radios of the WP-WIFI6 pluggable operate in 2x2 MIMO mode, with antenna ports A and B active. Upon exceeding the ambient temperature and airflow levels indicated in the thermal mitigation table, both 2.4 and 5 GHz radios may throttle to 1x1 SISO. In 1x1 SISO mode only antenna port A is active, and each radio is restricted to single spatial stream data rates.



CHAPTER 8

SSD Module

This chapter contains the following sections:

- [Introduction to the Solid State Drive in the IR1800 Series, on page 67](#)
- [Installing an SSD Module, on page 68](#)

Introduction to the Solid State Drive in the IR1800 Series

The IR1800 can use a Solid State Drive (SSD). The PID is IRM-SSD-100G.



Note The SSD can only be supported to a maximum temperature of 60C / 0LFM.

The following graphic shows an SSD module.

Figure 23: SSD Module



The highlights of the SSD module are:

- Provides an additional 100 GB of additional Flash memory storage.
- Provides space to store application data for Cisco IOx.
- The SSD is a Field Replaceable Unit, but is not hot-swappable.

Installing an SSD Module

This section provides an overview of an SSD module installation.



Caution

- Ensure that you are using proper static discharge techniques such as a wrist strap and static mat.
- Ensure that the device is powered down before performing the removal or installation of an SSD module.

Before you begin

Ensure the device is powered off.

Procedure

- Step 1** Remove the two screws (1) holding the cover of the SSD module slot as shown in the following figure. Retain these screws for future use.

Figure 24: SSD Module Cover



1

Screws

- Step 2** Insert the SSD module into the slot in the panel such that the previously removed screws (1) align with the screw holes (2), as shown in the following figure.

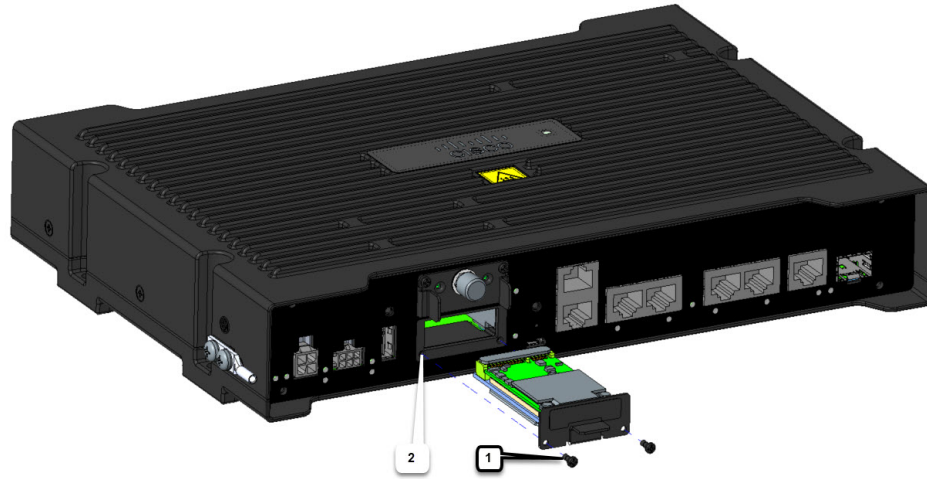
Figure 25: Module Placement

1	Screws
2	Screw holes

Step 3 After the module is properly inserted, tighten the module plate to the panel with the two screws. The screws should be torqued to 2-3 in-lb (0.2-0.3 Newton meter).

Step 4 The installation is now complete.



CHAPTER 9

GPS Field Replaceable Unit Module

This chapter contains the following sections:

- [Overview of the GPS FRU Module, on page 71](#)
- [Installation and Removal of a GPS FRU Module, on page 72](#)

Overview of the GPS FRU Module

The IR1833 and IR1835 have a slot for a dedicated GPS field-replaceable unit (FRU) module, which will be used in addition to the one integrated in the LTE module, for more accurate dead reckoning performance. The part number is IRM-GNSS-ADR.

The following figure shows a GPS FRU module.

Figure 26: GPS FRU Module

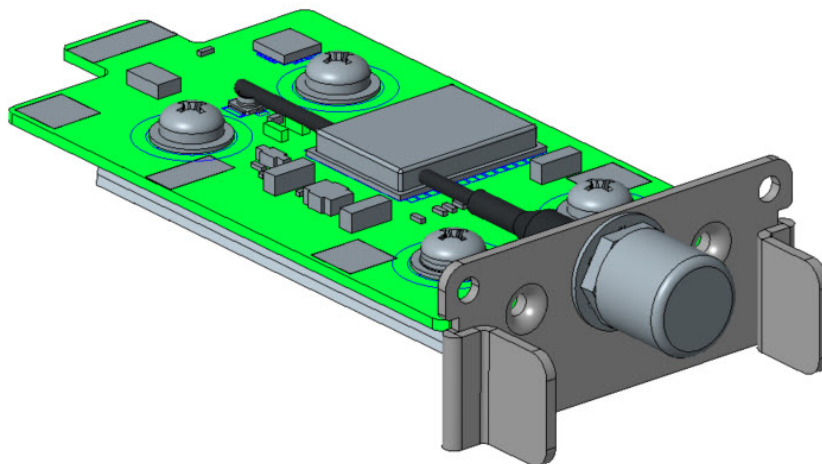

The IRM-GNSS-ADR hardware is capable of supporting various GNSS constellations. Cisco supports GPS only on this module with IOS XE release 17.7.1. Please inquire with your sales representative for a roadmap of support of additional constellations on the IRM-GNSS-ADR module.

Further details on the GPS capabilities can be found in the [Cisco Catalyst IR1800 Rugged Series Router Software Configuration Guide](#).

Installation and Removal of a GPS FRU Module



Caution The module is a FRU, but is not hot swappable. Make sure the device is powered down before replacing.

Procedure

- Step 1** Remove the protective cover over the GPS slot by removing the two screws (1) using a Phillips driver, as shown in the following figure. Retain these two screws for further use.

Figure 27: GPS Slot Cover

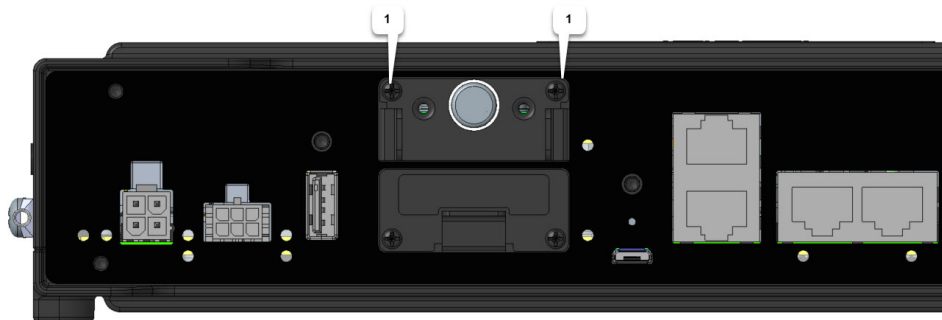

1	Screws
---	--------

- Step 2** Insert the GPS FRU module into the slot in the device.

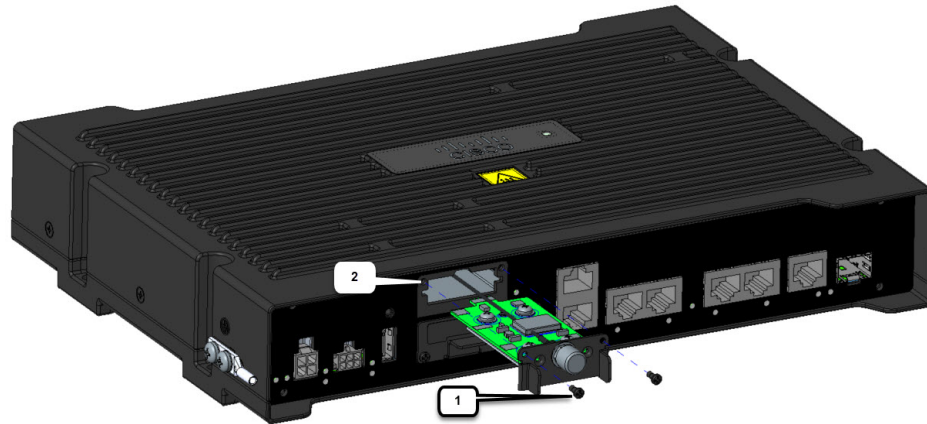
Figure 28: GPS Module Insertion

1	Screws
2	Screw holes

Step 3 Align the previously removed screws (1), with the screw holes (2), and tighten to 2-3 in-lb (0.2-0.3 Newton meter).

Step 4 The installation is now complete.

Step 5 To remove the module, reverse the steps:

- a. Power off the device.
- b. Remove the screws.
- c. Pull out the module.



CHAPTER 10

Digital I/O, Ignition, and CAN Bus Connectivity

This chapter contains the following sections:

- [Overview of the Digital I/O, Ignition, and CAN Bus Connectivity](#) , on page 75
- [Digital I/O Features](#), on page 75
- [Controller Area Network Bus Features](#), on page 77
- [On-Board Diagnostic \(OBD-II\)](#), on page 78

Overview of the Digital I/O, Ignition, and CAN Bus Connectivity

The connector has four GPIO connections, one Return connection, and one Ignition connection. The Digital I/O supports both Dry and Wet contacts up to 60 V.

- Dry contact is isolated from a voltage source (or no volt), with an embedded relay function (NPN transistor), usually used to indicate an event, for example, open/close, alarm.
- Wet contact is a contact with external power (+3.3V to +60V, and a maximum 150mA of current allowed at high voltage) applied, and is usually used to energize something, for example, solenoid, light.
- Connectivity for the CAN Bus is through two wires on the power connector that connects to the OBD-II connector of the vehicle.

Digital I/O Features

The common features of Digital I/O are:

- Withstands up to 60V applied at the terminal.
- Protected from reverse voltage and causes no damage to the equipment.
- Digital input and output can coexist on different channels.
- LED Indicator: Provisionable; On: Active, Off: Non-active.
- 4kV surge protected (IEC 61000-4-5).

The Digital I/O Connector

The following figure shows the connector.

Figure 29: Digital I/O Connector



Note The default state of the Digital I/O is input, the open-collector is open (off).

The power connector pinouts are as follows:

- Top Row: Pins 6, 5, 4
- Bottom Row: Pins 3, 2, 1

The pinouts for the Digital I/O are described in the following table.

Table 25: Digital I/O Pinouts

Pin #	Name	Direction	Description
1	DIGI_IO_1	I/O	Digital IO Port 3
2	GND	—	Ground
3	DIGI_IO_3	I/O	Digital IO Port 2
4	DIGI_IO_2	I/O	Digital IO Port 4
5	Ignition	In	Ignition input (6V - 36V)
6	DIGI_IO_4	I/O	Digital IO Port 1

Vehicle Connections

When connecting to automotive power, it is expected that the ignition output will be +12 VDC, or +24 VDC (following the battery voltage). Connect the ignition input of the router to the ignition output of the automobile. The DC In + and DC In - leads can be directly connected to the battery. However, we recommend that you connect them after a fuse.



Important For vehicle installations, it is required to connect the ignition input, and use the Ignition Power Management feature of the router. This eliminates unnecessary power cycling of the router whenever the vehicle is turned off and then turned back on.

Digital I/O Specifications

Digital I/O specifications are described in the following tables.

Table 26: Digital Input Specifications

Specification	Minimum	Maximum	Unit
Input Voltage High	2.2	60	Volts
Input Voltage Low	—	1.2	Volts
Input Current	—	0.68mA	mA



Note Current is flowing out of the terminal although it is an input, that is, sourcing. The current is flowing in the terminal for the output, that is, sinking.

Table 27: Digital Output Specifications

Specification	Minimum	Maximum	Unit	Notes
Output Voltage High	2.5	—	Volts	No external voltage applied.
Output Voltage Low	—	0.4	Volts	No external voltage applied.
Internal Pull-Up Resistance	1K – 1%	1K – 1%	Ohms	—
Internal Pull-Up Voltage	—	3	Volts	—
External Pull-Up Voltage	3.3	60	Volts	External resistance required to limit current to 200mA.
Sink Current	—	200	mA	—

Controller Area Network Bus Features

The IR1800 features support for the Controller Area Network (CAN) Bus interface through two wires that connect to the OBD-II connector of the vehicle.

The following are some of the characteristics of the CAN Bus:

- CAN Bus enables the ECU (electronic control unit) in a vehicle to communicate with all other ECUs
- Consists of two wires: CAN Bus High and Low, supporting data rate up to 1 Mbs
- High-speed CAN Bus 2.0B: ISO 11898-1 data link layer, ISO 11898-2 and ISO-11898-5 physical layer up to 1 Mbs data rate (software dependent)
- Maximum cable length between 500 m (125 kbit/s) and 40 m (1 Mbit/s)
- 120-ohms CAN Bus termination

- There is no hardware mechanism to detect if an ODB II connector is attached

Can Bus Power Connector

The CAN_P and CAN_N signals are connected to two pins of the 4-pin mini-fit power connector. A cable can be connected from the mini-fit connector to the OBD-II connector of the vehicle to get both unswitched power and CAN interface input.

The pinouts are shown in the following figure.

Figure 30: Power Connector

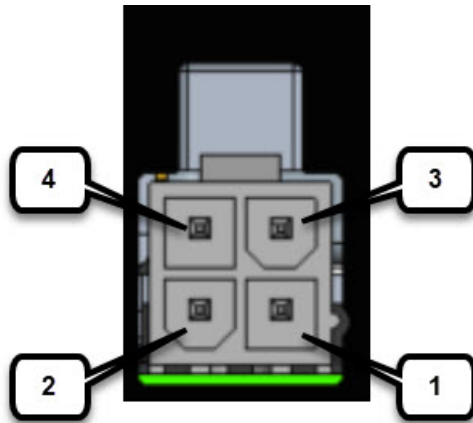

Table 28: Power Connector Descriptions

Pin Number	Name	Description
1	DC -	DC Power Return (GND-)
2	CAN_P	CAN Bus Differential Signal
3	DC +	DC Power Input (12V, 24V)
4	CAN_N	CAN Bus Differential Signal

On-Board Diagnostic (OBD-II)

The following are some of the characteristics of On-Board Diagnostic (OBD-II):

- OBD or OBDI standardizes the connector so that it is identical in all the vehicles
- The communication protocol remains somewhat specific depending on the make of the vehicle
- The OBDII port is always powered up, even when the vehicle is turned off
- When connecting an IR1800 CAN Bus, the vehicles owner must review the characteristics of the ODB2 power and fuse protection

The following are the different types of OBD-II cables depending on the model of vehicle you are installing the router in.

Table 29: OBD-II Cable Descriptions

OBD2-J1962YA-MF4	OBD-II (J1962) Type A to Router cable with type 1 Y
OBD2-J1962YB-MF4	OBD-II (J1962) Type B to Router cable with type 2 Y
OBD2-J1939Y2-MF4	OBD-II (J1939) Type 2 heavy duty diagnostic harness for Volvo
OBD2-J1939Y1-MF4	OBD-II (J1939) Type 1 to Router cable with type 1 Y
OBD2-J1708Y-MF4	OBD-II (J1708) to Router cable with type 1 y-split
OBD2-J1962VMB-MF4	J1962-VM-Type B Volvo & Mack

The list of cables is illustrated in the following figure. The box labeled Vehicle Conn is the connector that is connected to a car or truck. The box labeled Tool Conn is for attaching diagnostic tool. The box labeled MiniFit-Jr is the connector that connects to the IR1800.

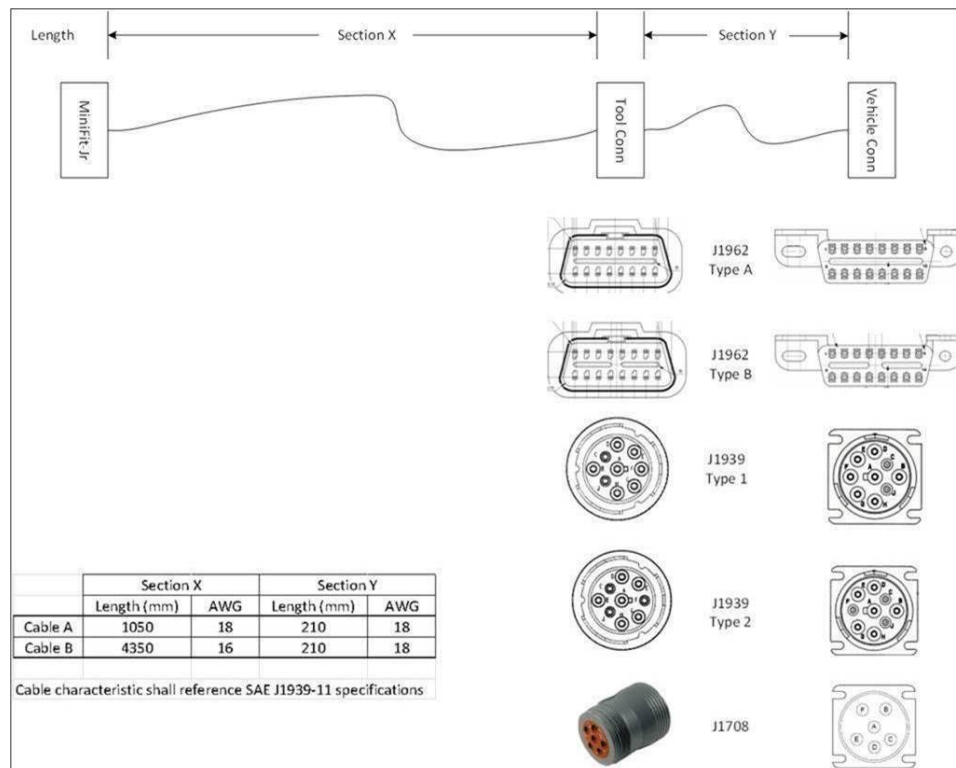



CHAPTER 11

Connecting the Router

This chapter contains the following sections:

- [Overview of the IR1800 Connecting Process, on page 81](#)
- [Preparing to Connect the Router, on page 81](#)
- [Connecting a PC to the Console Port, on page 82](#)
- [Connecting to DC Power and CAN Bus Wiring, on page 83](#)
- [Verifying Connections, on page 84](#)

Overview of the IR1800 Connecting Process

This chapter describes how to connect the IR1800 to Ground, Power, Ethernet devices and a network.

Preparing to Connect the Router

Before you connect the router to the devices, install the router according to the instructions in [Installing the Router, on page 23](#).

Preventing Damage to the Router

To prevent damage to your router, turn off the power to the devices and to the router until all connections are completed.

For hazardous location environments, follow these warnings when connecting to destination ports (antenna, serial, Ethernet, and console ports).



Warning

If you connect or disconnect the console cable with power applied to the switch or any device on the network, an electrical arc can occur. This could cause an explosion in hazardous location installations. Be sure that power is removed or the area is nonhazardous before proceeding. **Statement 1080**

**Warning**

Do not connect or disconnect cables to the ports while power is applied to the switch or any device on the network because an electrical arc can occur. This could cause an explosion in hazardous location installations. Be sure that power is removed from the switch and cannot be accidentally be turned on, or verify that the area is nonhazardous before proceeding. **Statement 1070**

**Caution**

Do not turn on the devices until you have completed all the connections to the router.

Connecting a PC, Server, or Workstation

To connect a PC (or other Ethernet devices) to an Ethernet switch port, follow these steps.

Procedure

-
- Step 1** Connect one end of the Ethernet cable to an Ethernet switch port on the router.
 - Step 2** Connect the other end of the cable to the RJ-45 port on the network interface card (NIC) that is installed in the PC, server, or workstation.
 - Step 3** (Optional) Connect additional servers, PCs, or workstations to the other Ethernet switch ports.
-

Connecting a PC to the Console Port

Connect a PC to the console port either to configure the software by using the CLI, or to troubleshoot problems with the router.

To connect a terminal or PC to the console port on the router and access the CLI, follow these steps:

Procedure

-
- Step 1** Connect the Micro-B USB console cable to the console port on the router.
 - Step 2** Connect the opposite end of the micro-USB cable to the USB port on your laptop or PC.
 - Step 3** To communicate with the router, wait for your laptop or PC to discover the new device.
 - Step 4** If your laptop or PC warns you that you do not have the proper drivers to communicate with the router, you can obtain them from your computer manufacturer or from this location:

<https://www.silabs.com/developers/usb-to-uart-bridge-vcp-drivers>

Connecting to DC Power and CAN Bus Wiring



Warning This product relies on the building's installation for short-circuit (overcurrent) protection. Ensure that the protective device is rated not greater than 60 VDC minimum, 5A maximum. **Statement 1005**



Warning Connect the unit only to DC power source that complies with the safety extra-low voltage (SELV) requirements in IEC 60950 and IEC 62368 based safety standards. **Statement 1033**



Warning This product requires short-circuit (overcurrent) protection, to be provided as part of the building installation. Install only in accordance with national and local wiring regulations. **Statement 1045**



Warning When you connect or disconnect the power and/or alarm connector with power applied, an electrical arc can occur. This could cause an explosion in hazardous area installations. Be sure that all power is removed from the switch and any other circuits. Be sure that power cannot be accidentally turned on or verify that the area is nonhazardous before proceeding. **Statement 1058**



Warning Explosion Hazard—The area must be known to be nonhazardous before installing, servicing, or replacing the unit. **Statement 1082**



Warning Explosion Hazard—Substitution of components may impair suitability for Class I, Division 2/Zone 2. **Statement 1083**

Plugs and Pinouts

The IR1800 uses a DC power accessory kit (part number PWR-MF4-125W-AC). This needs to be ordered separately. The power entry receptacle is on the IR1800. The pinouts are shown in the following figure.

Figure 31: Power Connector Pinouts

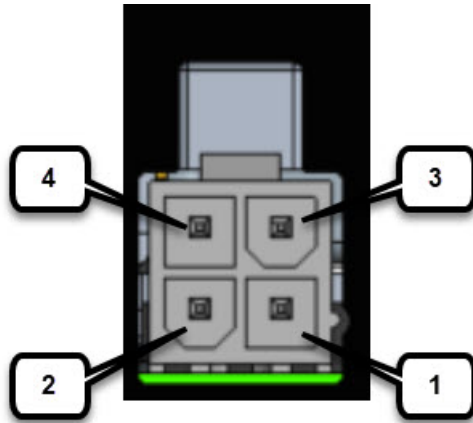
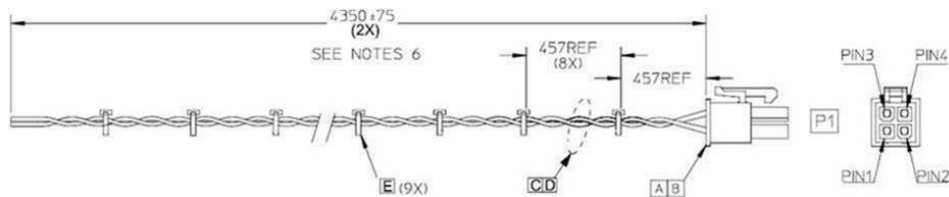

Table 30: Power Connector Descriptions

Pin Number	Name	Description
1	DC -	DC Power Return (GND-)
2	CAN_P	CAN Bus Differential Signal
3	DC +	DC Power Input (12V, 24V)
4	CAN_N	CAN Bus Differential Signal

The IR1800 can be installed without connecting to the CAN Bus. There is a 2-wire cable that can be ordered (CAB-PWR-15-MF4). The following is a diagram of the cable:



Verifying Connections

To verify that all the devices are properly connected to the router, turn on all the connected devices, and then check the LEDs.



CHAPTER 12

Installing the IP54 Kit

This chapter contains the following sections:

- [Overview of the IP54 Kit, on page 85](#)
- [Installing the IP54 Kit, on page 87](#)

Overview of the IP54 Kit

The IR1800 has a kit, which when installed, provides dust and water protection and discourages tampering.

The PID is IR1800-IP54-KIT.

Before you begin, make sure that you have completed all of the standard installation steps described in the earlier chapters of this guide.



Caution The IP54 kit installed with the router is not intended to meet the Hazardous Locations IP54 requirement according to IEC 60079-7:2018, clause 23.



Caution All the cabling that extends from the router and gets terminated elsewhere, that is, Power, Ethernet, Antenna, and so on, must have a minimum ingress protection rating of IP54 according to EN60529 when used in conjunction with the IP54 kit. It is the responsibility of the customer to ensure that all cabling and terminations outside of the router meet the required ingress protection requirement. In addition, the router is *not* designed for and should not be placed outdoors. The intent of the IP54 kit is to provide supplementary protection to the router against dust and occasional splashing water. Cisco cannot guarantee prolonged reliable operation of the router if these guidelines are violated.



Caution Before beginning the installation of the IP54 kit, consider carefully whether the installation site is strong enough to support the combined weight of the IP54 enclosure and the router that it encloses.

The IP54 kit contains:

- Front Cover Components
- Back Cover

- Screws to build the kit and attach it to IR1800

The front cover is shipped disassembled because it must be assembled onto the IR1800. The front cover comprises four parts.

Figure 32: Front Cover Parts

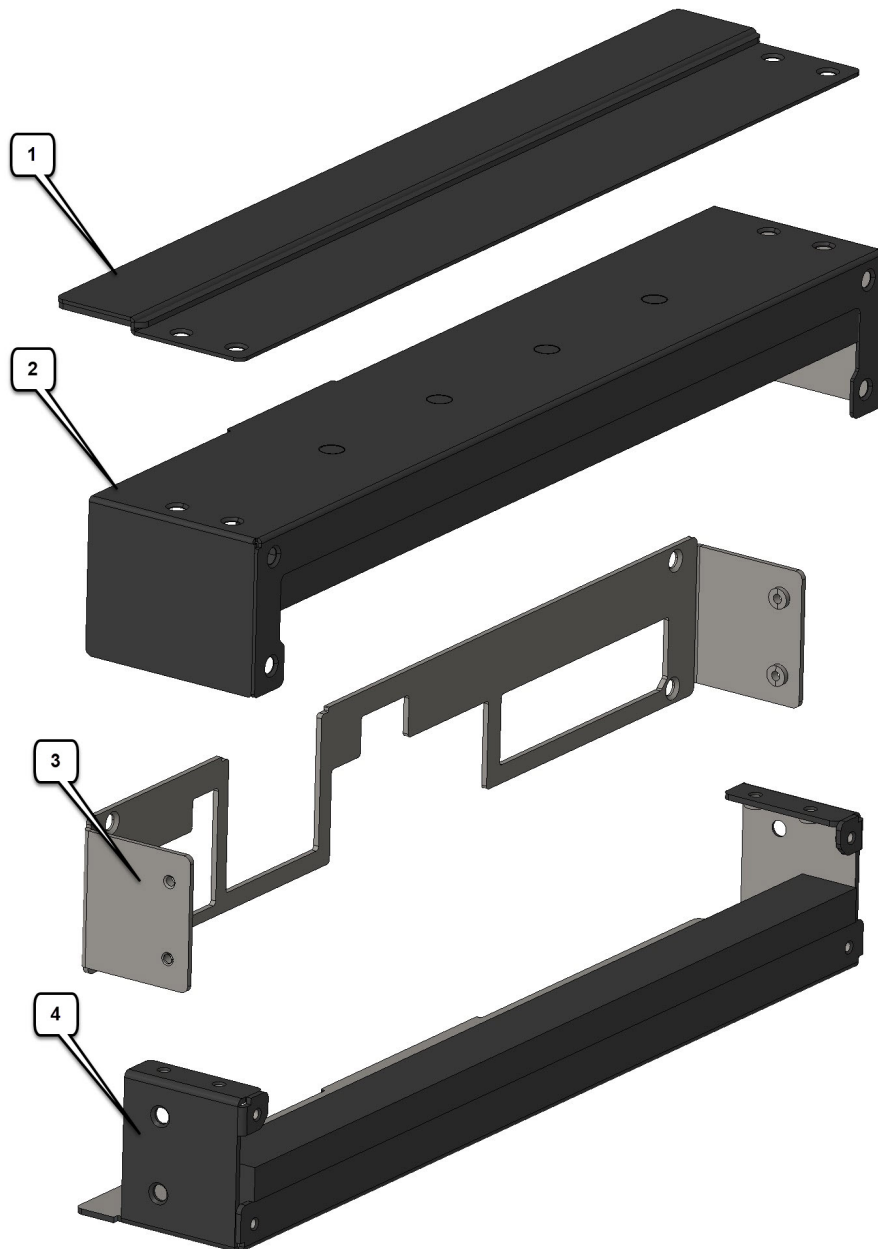

1	Top Cover Plate
---	-----------------

2	Top Cover
3	Mounting Plate
4	Bottom Cover

Figure 33: Back Cover Parts

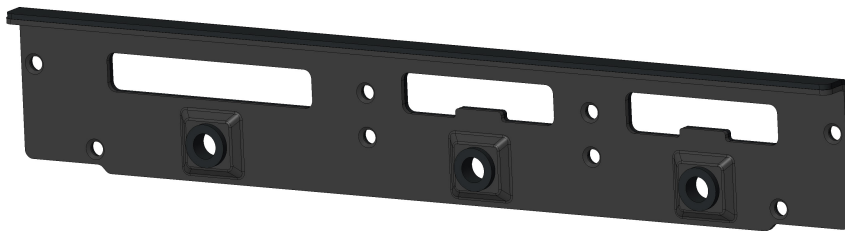

The IP54 back cover ships as one piece with eight screws.

Installing the IP54 Kit

This section provides an overview of the IP54 kit installation.



Note Ensure that you are using proper static discharge techniques such as a wrist strap and static mat.



Caution Ensure the device is powered down before performing any removal or installation of a module.

Installing the Front Cover

The front cover of the IP54 kit is installed around the IR1800 using the four parts previously listed and the screws provided.

Before you begin

Make sure all cables are removed and that the desired FRUs or blanks are installed before assembling the front IP54 cover.

Procedure

- Step 1** Attach the mounting plate to the front of the chassis using four of the provided screws.

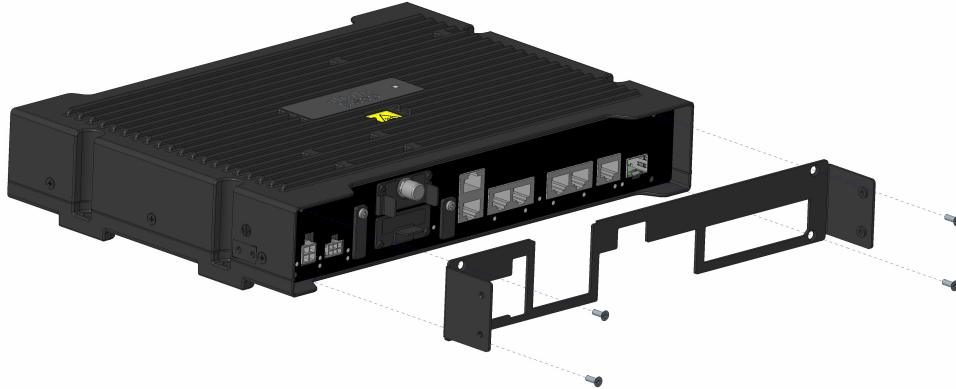

- Step 2** Tighten the screws to a torque of 5 to 6 in-lbs.

- Step 3** Attach the bottom cover to the mounting plate using four of the provided screws.



- Step 4** Plug in the power and all other cables after the bottom cover is attached. Drape all the cables over the foam seat.

- Step 5** Attach the top cover to the bottom cover using four of the provided screws.



Note All the cables should be wedged between the top and bottom foam pieces.

- Step 6** Attach the top cover plate to the top cover using four more of the provided screws.

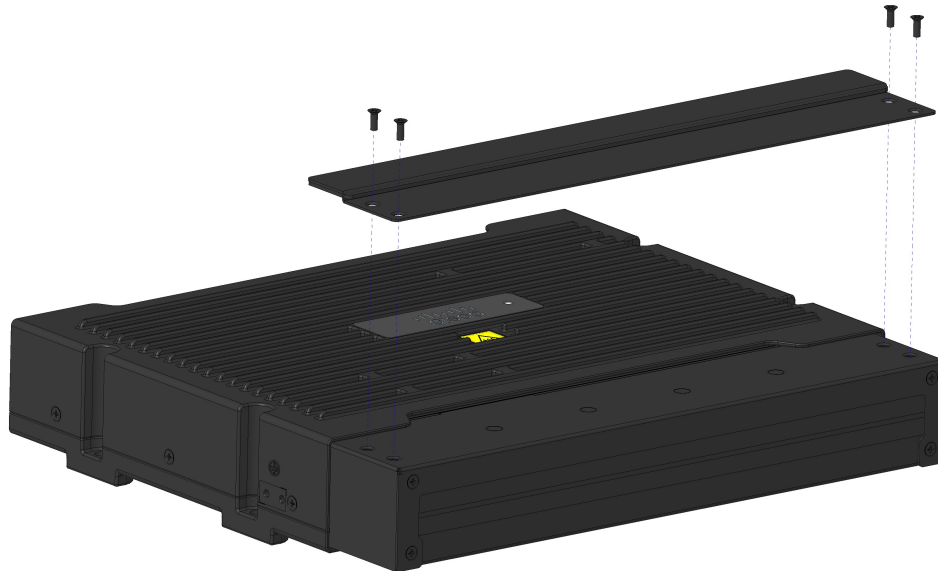

- Step 7** The following figure shows the final assembly.



Installing the Back Cover

The back cover is installed as a single piece using eight screws provided.

Procedure

- Step 1** Make sure that all the slots have pluggable modules or blanks, and that all the antennae are removed before attaching the back cover.
- Note** If your pluggable module has a USB port cover attached, remove the cover. If the USB port cover is installed along with the IP54 back cover, it will interfere with the installation.
- Step 2** Attach the back cover to the back of the chassis over the pluggable modules using eight of the provided screws.



Step 3 Tighten the screws to a torque of 5 to 6 in-lbs.

Step 4 After the cover is in place, the antenna cables can be attached to the pluggable modules, as needed. The following figure shows the final assembly.





CHAPTER 13

Technical Specifications

This chapter contains the following sections:

- [Overview of Technical Specifications for IR1800 Series Routers, on page 91](#)
- [Router Specifications, on page 91](#)

Overview of Technical Specifications for IR1800 Series Routers

This chapter provides specifications for the IR1800.

Complete specifications for the IR1800 can be found in the [marketing data sheet](#).

Router Specifications

The following table lists the specifications of the Cisco IR1800.

Description	Design Specification
Dimensions	11.00"W x 7.16" x 2.02"
Weight	2.4 kg (5.3 lb) (without any modules) 3.1 kg (6.8 lb) (fully configured)
Ingress Protection Rating	IP 40, IP54 with external kit attached.
Humidity	Noncondensing Relative Humidity: 5% to 95%

Description	Design Specification
Standard Safety Certifications	UL/CSA 60950-1 UL/CSA/EN/IEC 62368-1 CB report and certificate to IEC 60950-1 with all country deviations NOM to NOM-019-SCFI (through UL certificate of conformity) ANSI/ISA 12.12.01 (Class 1, Div 2, groups A-D) CSA 22.2 No. 213-17 UL/CSA 60079-0, -7 (Class 1, Zone 2, Gc/IIC) IEC 60079-0, -7 IECEx test report (Class 1, Zone 2, Gc/IIC) EN 60079-0, -7 ATEX certificate (Class 1, Zone 2, Gc/IIC)
Operating Temperature and Altitude	-40C to +70C (40 lfm Vented Enclosure) -40C to +60C (Sealed Enclosure) -34C to +74C (Min. 200 lfm Fan or Blower Equipped Enclosure) Altitude: up to 15,000 feet
Storage Temperature and Altitude	Temperature: -40 to +85 degrees C Altitude: up to 15,000 feet
Input Voltage	Nominal voltage: 12V/24V (+/-20%) Min/Max voltage: +9.6V to +36V DC input
Typical Current	5.5A
Typical/Maximum Power Consumption	65W



CHAPTER 14

Regulatory Compliance

This chapter contains the following sections:

- Related Documentation, on page 93
- Installation Warning and Caution Statements, on page 94
- Hazardous Locations Standards and Marking Strings, on page 95
- EMC Information, on page 96
- Class A Notice for FCC, on page 96
- Industry Canada, on page 97
- European Community, Switzerland, Norway, Iceland, and Liechtenstein, on page 98
- Declaration of Conformity for RF Exposure, on page 98
- EMC Class A Notices and Warnings, on page 101
- National Restrictions, on page 104
- Brazil Regulatory Information, on page 105
- Taiwan, on page 105
- **Statement 191**—Voluntary Control Council for Interference (VCCI) Class A Warning for Japan, on page 105
- **ステートメント 191**—日本向け VCCI クラス A に関する警告 (105 ページ)
- **Statement 1008**—Class 1 Laser Product, on page 106
- **ステートメント 1008**—クラス 1 レーザー製品 (106 ページ)
- **Statement 1051**—Laser Radiation, on page 106
- **ステートメント 1051**: レーザー放射 (106 ページ)
- **Statement 1255**—Laser Compliance Statement, on page 106
- **聲明4011**—國家通信委員會警告, on page 107
- Intended Use of equipment, on page 107
- Changing Output Power, on page 107
- Obtaining Documents from Cisco.com, on page 107

Related Documentation

The following are the various locations containing important information:

- Cisco.com: www.cisco.com
- Warranty Information: www.cisco-warrantyfinder.com

- Cisco Information Packet, consisting of Cisco Limited Warranty, Disclaimer of Warranty, End User License Agreement, and United States Federal Communications Commission Notice: www.cisco.com/en/US/docs/general/warranty/English/SL3DEN.html
- Cisco Marketplace: www.cisco.com/cgi-bin/marketplace/welcome.pl
- Cisco Product Documentation: www.cisco.com/go/techdocs
- Cisco Support: www.cisco.com/cisco/web/support/index.html

Installation Warning and Caution Statements

**Caution**

The equipment shall only be used in an area of at least pollution degree 2 as defined by EN 600079-0. In addition, the Equipment shall be installed in a certified enclosure that provides a degree of protection not less than IP 54 in accordance with EN IEC 60079-0 (for ATEX) or UL 60079-0 (for US Zones) and is accessible by a tool only.

**Caution**

When installed in a Class 1, Division 2 hazardous locations environment, equipment shall be installed in an enclosure suitable for the area. The enclosure shall be accessible by tool only. Note the two scenarios that follow:

1. **Installation with the IP54 Kit:** The equipment must be professionally installed in location meeting class 1 / div 2 requirements
2. **Installation without the IP54 Kit:** In this case, the equipment is IP40 rated. IP40 requires the customer to install the equipment in a suitable enclosure/cabinet accessible only by tool.

**Caution**

Airflow around the router must be unrestricted. The dimensions (height x width x depth) are 7.70 x 11 x 1.73 in. (19.6 x 27.9 x 4.39 cm). To prevent the router from overheating, there must be a minimum of 1.0 in. (25.4 mm) around all surfaces of the router. Contact your [Cisco Technical Assistance Centre \(TAC\)](#) if tighter spacing is required.

**Warning**

In order to comply with FCC radio frequency (RF) exposure limits, antennas for this product should be located a minimum of 11.8 in. (30 cm) or more from the body of all persons. **Statement 332**

**Warning**

This unit is intended for installation in restricted access areas. A restricted access area can be accessed only through the use of a special tool, lock and key, or other means of security. **Statement 1017**

**Warning**

To prevent the system from overheating, do not operate it in an area that exceeds the maximum recommended ambient temperature of 140°F (60°C). **Statement 1047**

**Warning**

Use twisted-pair supply wires suitable for 86°F (30°C) above surrounding ambient temperature outside the enclosure. **Statement 1067**

**Warning**

Avoid using or servicing any equipment that has outdoor connections during an electrical storm. There may be a risk of electric shock from lightning. **Statement 1088**

**Attention**

This product is a class A device for FCC compliance. Any mention of a class B compliance rating does not indicate this product meets those guidelines.

**Note**

This equipment is suitable for use in Class I, Division 2, Groups A, B, C, D, or only nonhazardous locations.

**Note**

This equipment is rated as follows- DC Input Voltage: Maximum Operating Range: 9.6V to 32VDC; Nominal: 12/24 VDC.

**Note**

This product is suitable for use in environmental air space in accordance with Section 300.22.C of the National Electrical Code and sections 2-128, 12-010(3), and 12-100 of the Canadian Electrical Code, Part 1, C22.1. You should not install the power supply or power injector in air-handling spaces.

**Note**

The maximum ambient operating temperature range is -40 to 140°F (-40 to 60°C).

Hazardous Locations Standards and Marking Strings

The following standards were used for the hazardous locations approvals and certifications:

- CSA C22.2 No. 60079-0:19, 4th Ed., Issued 2019-0
- CAN/CSA-C22.2 No. 60079-7:16, 2nd Ed., Issued 2016-10
- CSA C22.2 No. 213-17, 3rd Ed., Rev. 2019-08-26
- EN IEC 60079-0:2018 EN IEC 60079-7: 2015 +A1:2018
- EN IEC 60079-7: 2015 +A1:2018
- UL 121201, 9th Ed., Rev. 2019-08-26

- UL 60079-0 ,7th Ed., Rev. 2020-04-15
- UL 60079-7 5th Ed. Rev. 2017-04-21

The following hazardous locations strings are provided on the router:

- Class 1, Div 2, Groups A B C D
- Class I, Zone 2, AEx ec IIC T4 Gc
- UL 21 ATEX 2512X
- Ex ec IIC T4 Gc

EMC Information

For EMC and safety information, see the [Regulatory Compliance and Safety Information for Cisco IoT Series Routers](#) document.

Class A Notice for FCC

Modifying the equipment without Cisco's authorization may result in the equipment no longer complying with FCC requirements for Class A digital devices. In such an event, your right to use the equipment may be limited by FCC regulations, and you may be required to correct any interference to radio or television communications at your own expense.

This equipment has been tested and found to comply with the limits for a Class A digital device, pursuant to Part 15 of the FCC Rules. Operation is subject to the following two conditions:

1. This device may not cause harmful interference, and
2. This device must accept any interference received, including interference that may cause undesired operation.

This device operates in the : 5150-5250, 5250-5350, 5470-5725, and 5725-5850 MHz bands and may be operated indoor or outdoors per FCC guidance.



Caution The Part 15 radio device operates on a noninterference basis with other devices operating at this frequency when using the integrated antennas. Any changes or modification to the product not expressly approved by Cisco could void the user's authority to operate this device.



Caution Within the 5.15 to 5.25-GHz and 5.47 to 5.725-GHz bands, this device is restricted to indoor operations to reduce any potential for harmful interference to cochannel Mobile Satellite System (MSS) operations.

Industry Canada

Canadian Compliance Statement

Cisco® Catalyst IR1800 Rugged Series Router

Cisco® IR1800 Industrial Integrated Services Router PIDS

- IR1821
- IR1831
- IR1833
- IR1835

Industry Canada Certification Number

- 2461A-WPWIFI6

This Class A Digital apparatus meets all the requirements of the Canadian Interference-Causing Equipment Regulations.

This device complies with Class A Limits of Industry Canada. Operation is subject to the following two conditions:

1. This device may not cause harmful interference, and
2. This device must accept any interference received, including interference that may cause undesired operation.

Cisco® Catalyst IR1800 Rugged Series Router are certified to the requirements of RSS-247. The use of this device in a system operating either partially or completely outdoors may require the user to obtain a license for the system according to the Canadian regulations. For further information, contact your local Industry Canada office.

This device has been designed to operate with antennas having a maximum gain of 8 dBi. Antennas having a gain greater than 8 dBi are strictly prohibited for use with this device. The required antenna impedance is 50 ohms.

To reduce potential radio interference to other users, the antenna type and its gain should be so chosen that the equivalent isotropically radiated power (EIRP) is not more than that permitted for successful communication.

Operation in the band 5150-5250 MHz is only for indoor use to reduce the potential for harmful interference to co-channel mobile satellite systems.

Users are advised that high-power radars are allocated as primary users (i.e. priority users) of the bands 5250-5350 MHz and 5650-5850 MHz and that these radars could cause interference and/or damage to LE-LAN devices.

This device complies with Industry Canada license-exempt RSS standard(s). Operation is subject to the following two conditions: (1) this device may not cause interference, and (2) this device must accept any interference, including interference that may cause undesired operation of the device.

European Community, Switzerland, Norway, Iceland, and Liechtenstein

Cisco® Catalyst IR1800 Rugged Series Router PIDS.

- IR1821
- IR1831
- IR1833
- IR1835

Declaration of Conformity with Regard to R-ED Directive 2014/53/EU

The following standards are applied:

- ETSI EN 301 489-1 V2.2.3; EN 301 489 - 17 v3.2.4
- Draft ETSI EN 301 489-19 V2.2.0 (2020-09)
- Draft ETSI EN 301 489-52 V1.1.2
- Health & Safety-EN 62368-1; EN 50835:2017
- Radio-EN 300 328 v2.2.2; EN 301 893 v 2.1.1 , EN 62311:2019

The conformity assessment procedure referred to in Article 10.4 and Annex III of Directive 2014/53/EU has been followed.



Note This equipment is intended to be used in all EU and EFTA countries. Outdoor use may be restricted to certain frequencies or may require a license for operation or both. For more details, contact the Cisco Corporate Compliance team.

The product carries the CE mark:



Declaration of Conformity for RF Exposure

This section contains information on compliance, with guidelines related to RF exposure.

RF Exposure

Cisco products are designed to comply with the following national and international standards on human exposure to RF:

- US 47 Code of Federal Regulations Part 2 Subpart J

- American National Standards Institute (ANSI) / Institute of Electrical and Electronic Engineers / IEEE C 95.1
- International Commission on Non Ionizing Radiation Protection (ICNIRP)
- Ministry of Health (Canada) Safety Code 6. Limits on Human Exposure to Radio Frequency Fields in the range from 3kHz to 300 GHz
- Australia Radiation Protection Standard



Note To ensure compliance with various national and international Electromagnetic Field (EMF) standards, the system should only be operated with Cisco-approved antennas and accessories.

This Device Meets International Guidelines for Exposure to Radio Waves

The IR1800 Series device includes a radio transmitter and receiver. It is designed to not exceed the limits for exposure to radio waves (radio frequency electromagnetic fields) recommended by international guidelines. The guidelines were developed by an independent scientific organization (ICNIRP) and include a substantial safety margin designed to ensure the safety of all persons, regardless of age and health.

As such the systems are designed to be operated as to avoid contact with the antennas by the end user. We recommend that you set the system in a location where the antennas can remain at least at a minimum distance, as specified, from a user in accordance with the regulatory guidelines that are designed to reduce the overall exposure to a user or operator.

The World Health Organization has stated that present scientific information does not indicate the need for any special precautions for the use of wireless devices. They recommend that if you are interested in further reducing your exposure, then you can easily do so by reorienting antennas away from users, or by placing the antennas at a greater distance than recommended.

This Device Meets FCC Guidelines for Exposure to Radio Waves

The IR1800 Series device includes a radio transmitter and receiver. It is designed to not exceed the limits for exposure to radio waves (radio frequency electromagnetic fields) as referenced in FCC Part 1.1310. The guidelines are based on IEEE ANSI C 95.1 and include a substantial safety margin designed to ensure the safety of all persons, regardless of age and health.

As such the systems are designed to be operated so as to avoid contact with the antennas by the end user. We recommend that you set the system in a location where the antennas can remain at least at a minimum distance, as specified, from a user in accordance with the regulatory guidelines that are designed to reduce the overall exposure to a user or operator.

The device has been tested and found compliant with the applicable regulations as part of the radio certification process.

The U.S. Food and Drug Administration has stated that present scientific information does not indicate the need for any special precautions for the use of wireless devices. The FCC recommends that if you are interested in further reducing your exposure, you can easily do so by reorienting antennas away from users, or by placing the antennas at a greater distance than recommended, or by lowering the transmitter power output.



Note As per FCC ECFR 2.1091 and 2.1093 exempt criteria, single transmissions are exempted from the RF Exposure calculation. The calculation considers 100 percent of the duty cycle for all simultaneous transmission technology. The RF Exposure Calculation is done without compensating cable and connector losses. The RF Exposure calculation is performed with the highest supported antenna gain.

FCC Radiation Exposure Statement

This equipment complies with FCC radiation exposure limits set forth for an uncontrolled environment. This equipment should be installed and operated with minimum distance 30cm between the radiator and your body.

This device contains licence-exempt transmitter(s)/receiver(s) that comply with Innovation, Science and Economic Development Canada's licence-exempt RSS(s). Operation is subject to the following two conditions:

1. This device may not cause interference.
2. This device must accept any interference, including interference that may cause undesired operation of the device.

L'émetteur/récepteur exempt de licence contenu dans le présent appareil est conforme aux CNR d'Innovation, Sciences et Développement économique Canada applicables aux appareils radio exempts de licence. L'exploitation est autorisée aux deux conditions suivantes :

1. L'appareil ne doit pas produire de brouillage;
2. L'appareil doit accepter tout brouillage radioélectrique subi, même si le brouillage est susceptible d'en compromettre le fonctionnement.

This Device Meets the Industry Canada Guidelines for Exposure to Radio Waves

The IR1800 Series includes a radio transmitter and receiver. It is designed to not exceed the limits for exposure to radio waves (radio frequency electromagnetic fields) as referenced in Health Canada Safety Code 6. The guidelines include a substantial safety margin designed into the limit to ensure the safety of all persons, regardless of age and health.

As such the systems are designed to be operated so as to avoid contact with the antennas by the end user. We recommend that you set the system in a location where the antennas can remain at least a minimum distance, as specified, from a user in accordance with the regulatory guidelines that are designed to reduce the overall exposure to a user or operator.

Separation Distance		
MPE	Distance	Limit
1.1 mW/Cm2 with Simultaneous Transmission of Dual Cellular Modem, 2.4-GHz Wi-Fi and 5-GHz Wi-Fi.	30 cm (11.8 inches)	1.00 mW/cm2



Note Health Canada states that present scientific information does not indicate the need for any special precautions for the use of wireless devices. They recommend that if you are interested in further reducing your exposure, you can easily do so by reorienting antennas away from users by placing the antennas at a greater distance than recommended, or by lowering the transmitter power output.

ISED Radiation Exposure Statement

This equipment complies with ISED RSS-102 radiation exposure limits set forth for an uncontrolled environment. This equipment should be installed and operated with minimum distance 30cm between the radiator & your body.

Cet équipement est conforme aux limites d'exposition aux rayonnements ISED établies pour un environnement non contrôlé. Cet équipement doit être installé et utilisé avec un minimum de 30cm de distance entre la source de rayonnement et votre corps

Le module émetteur peut ne pas être coïmplanté avec un autre émetteur ou antenne.

CAN ICES-3 (A)/NMB-3(A)

The Country Code Selection feature is disabled for products marketed in the US/Canada.

Additional Information on RF Exposure

You can find additional information on RF exposure in the following links:

- FCC Bulletin 56: Questions and Answers about Biological Effects and Potential Hazards of Radio Frequency Electromagnetic Fields
- FCC Bulletin 65: Evaluating Compliance with the FCC guidelines for Human Exposure to Radio Frequency Electromagnetic Fields
- FCC Bulletin 65C (01-01): Evaluating Compliance with the FCC guidelines for Human Exposure to Radio Frequency Electromagnetic Fields: Additional Information for Evaluating Compliance for Mobile and Portable Devices with FCC limits for Human Exposure to Radio Frequency Emission

You can obtain additional information from the following organizations:

- World Health Organization Internal Commission on Non-Ionizing Radiation Protection at this URL: <https://www.icnirp.org>
- United Kingdom, Wi-fi radio waves and health at this URL: <https://www.gov.uk/government/publications/wireless-networks-wi-fi-radio-waves-and-health/wi-fi-radio-waves-and-health>
- Cellular Telecommunications Association at this URL: <https://www.ctia.org/>
- The Mobile Manufacturers Forum at this URL: <https://www.mwfai.org/>

EMC Class A Notices and Warnings

Statement 340—Class A Warning for CISPR32

Danger	Warnung	Danger	Dies ist ein Produkt der Klasse A. Bei der Verwendung dieses Produkts im Haus- oder Wohnungsbereich kann es zu Funkstörungen kommen. In diesem Fall muss der Benutzer u. U. angemessene Maßnahmen ergreifen.
---------------	---------	---------------	--------------------------------------------------------------------------------------------------------------------------------------------------------------------------------------------------------------

Declaration of Conformity with Regard to EU Directive 2014/53/EU

The information in this document is applicable to the Cisco IR1800 Series wireless LAN products.

The equipment operates in the 2400 to 2483.5 MHz, the 5150 to 5350 MHz, and the 5470 to 5725 MHz frequency range.

The WP-WIFI6 module supports only 2400 to 2483.5 and 5470 to 5725 MHz.

National regulations may require operations to be limited to portions of the frequency ranges identified above or at reduced power levels, or both. See the [National Restrictions](#) section for complete details.

This declaration is only valid for configurations (combinations of software, firmware and hardware), provided or supported by Cisco Systems for use within the EU or countries that have implemented the EU directives. The use of software or firmware not supported or provided by Cisco Systems may result in the equipment not being compliant with the regulatory requirements.

Table 31: Country Statements

Country	Statement
Български [Bulgarian]	Това оборудване отговаря на съществените изисквания и приложими клаузи на Директива 2014/53/ЕС.
Česky [Czech]:	Toto zařízení je v souladu se základními požadavky a ostatními odpovídajícími ustanoveními Směrnice 2014/53/EU.
Dansk [Danish]:	Dette udstyr er i overensstemmelse med de væsentlige krav og andre relevante bestemmelser i Direktiv 2014/53/EU.
Deutsch [German]:	Dieses Gerät entspricht den grundlegenden Anforderungen und den weiteren entsprechenden Vorgaben der Richtlinie 2014/53/EU.
Eesti [Estonian]:	See seade vastab direktiivi 2014/53/EL olulistele nõuetele ja teistele asjakohastele sätetele.
English:	This equipment is in compliance with the essential requirements and other relevant provisions of Directive 2014/53/EU.
Español [Spanish]:	Este equipo cumple con los requisitos esenciales así como con otras disposiciones de la Directiva 2014/53/UE.
Ελληνική [Greek]:	Αυτός ο εξοπλισμός είναι σε συμμόρφωση με τις ουσιώδεις απαιτήσεις και άλλες σχετικές διατάξεις της Οδηγίας 2014/53/ΕΕ.
Français [French]:	Cet appareil est conforme aux exigences essentielles et aux autres dispositions pertinentes de la Directive 2014/53/UE.

Country	Statement
Hrvatski:[Croatian]	Ova oprema je u skladnosti s bitnim zahtjevima i drugim relevantnim odredbama Direktive 2014/53/EU
Íslenska [Icelandic]:	Þetta tæki er samkvæmt grunnkröfum og öðrum viðeigandi ákvæðum Tilskipunar 2014/53/EU.
Italiano [Italian]:	Questo apparato é conforme ai requisiti essenziali ed agli altri principi sanciti dalla Direttiva 2014/53/UE.
Latviski [Latvian]:	Šī iekārta atbilst Direktīvas 2014/53/ES būtiskajām prasībām un citiem ar to saistītajiem noteikumiem.
Lietuvių [Lithuanian]:	Šis įrenginys tenkina 2014/53/ES Direktyvos esminius reikalavimus ir kitas šios direktyvos nuostatas.
Nederlands [Dutch]:	Dit apparaat voldoet aan de essentiële eisen en andere van toepassing zijnde bepalingen van de Richtlijn 2014/53/EU.
Malti [Maltese]:	Dan l-apparat huwa konformi mal-htigiet essenzjali u l-provedimenti l-oħra rilevanti tad-Direttiva 2014/53/UE.
Magyar [Hungarian]:	Ez a készülék teljesíti az alapvető követelményeket és más 2014/53/EU irányelvben meghatározott vonatkozó rendelkezéseket.
Norsk [Norwegian]:	Dette utstyret er i samsvar med de grunnleggende krav og andre relevante bestemmelser i EU-direktiv 2014/53/EU.
Polski [Polish]:	Urządzenie jest zgodne z ogólnymi wymaganiami oraz szczególnymi warunkami określonymi Dyrektywą UE: 2014/53/UE.
Português [Portuguese]:	Este equipamento está em conformidade com os requisitos essenciais e outras provisões relevantes da Directiva 2014/53/UE.
Română [Romanian]	Acest echipament este în conformitate cu cerințele esențiale și cu alte prevederi relevante ale Directivei 2014/53/EU.
Slovensko [Slovenian]:	Ta naprava je skladna z bistvenimi zahtevami in ostalimi relevantnimi pogoji Direktive 2014/53/UE.
Slovensky [Slovak]:	Toto zariadenie je v zhode so základnými požiadavkami a inými príslušnými nariadeniami direktív: 2014/53/EÚ.
Suomi [Finnish]:	Tämä laite täyttää direktiivin 2014/53/EU olennaiset vaatimukset ja on siinä asetettujen muiden laitetta koskevien määräysten mukainen.
Svenska [Swedish]:	Denna utrustning är i överensstämmelse med de väsentliga kraven och andra relevanta bestämmelser i Direktiv 2014/53/EU.
Türk [Turkish]	Bu cihaz 2014/53/EU Direktifi'nin temel gereklerine ve ilgili diğer hükümlerine uygundur.

National Restrictions

In the EU and other European countries, the 2.4-GHz and 5-GHz bands have been made available for use by wireless LANs.

The IR1800 Series is intended for outdoor usage.



Note Products that can operate in the 5150 to 5350-MHz frequency band are restricted to indoor use only.

The following sections identify the countries having additional requirements or restrictions.

Denmark

In Denmark, the band 5150 to 5350 MHz is also allowed for outdoor usage.

I Danmark må frekvensbåndet 5150 - 5350 også anvendes udendørs.

Italy

This product meets the National Radio Interface and the requirements specified in the National Frequency Allocation Table for Italy. Unless this wireless LAN product is operating within the boundaries of the owner's property, its use requires a "general authorization". For details, see:

<http://www.mise.gov.it/index.php/it/comunicazioni>

Questo prodotto è conforme alla specifiche di Interfaccia Radio Nazionali e rispetta il Piano Nazionale di ripartizione delle frequenze in Italia. Se non viene installato all'interno del proprio fondo, l'utilizzo di prodotti Wireless LAN richiede una "Autorizzazione Generale". Consultare

<http://www.mise.gov.it/index.php/it/comunicazioni>

Latvia

The outdoor usage of the 2.4-GHz band requires an authorization from the Electronic Communications Office. For details, see: <http://www.esd.lv>.

2,4 GHz frekvenču joslas izmantošanai ārpus telpām nepieciešama atļauja no Elektronisko sakaru direkcijas. Vairāk informācijas: <http://www.esd.lv>.



Note Although Norway, Switzerland, Liechtenstein, and Turkey are not EU member states, the EU Directive 2014/53/EU has also been implemented in those countries.



Note The antenna gain mentioned does not include cable loss. For all combinations, the total of power level, antenna gain, and cable loss is equal to or below 43.5 dBm (EIRP).

Brazil Regulatory Information

English Translation

This equipment is not entitled to the protection from harmful interference and may not cause interference with duly authorized systems.

Portuguese Translation

Este equipamento não tem direito à proteção contra interferência prejudicial e não pode causar interferência em sistemas devidamente autorizados.

Taiwan

BSMI Class A warning

此為甲類資訊技術設備，於居住環境中使用時，可能會造成射頻擾動，在此種情況下，使用者會被要求採取某些適當的對策

Statement 191—Voluntary Control Council for Interference (VCCI) Class A Warning for Japan



Warning

This is a Class A product based on the standard of the VCCI Council. If this equipment is used in a domestic environment, radio interference may occur, in which case, you may be required to take corrective actions.

ステートメント 191—日本向け VCCI クラス A に関する警告



警告

この装置は、クラス A 機器です。この装置を住宅環境で使用すると電波妨害を引き起こすことがあります。この場合には使用者が適切な対策を講ずるよう要求されることがあります。

VCCI-A

Statement 1008—Class 1 Laser Product



Warning This product is a Class 1 laser product.

ステートメント 1008—クラス 1 レーザー製品



警告 クラス 1 レーザー製品です。

Statement 1051—Laser Radiation



Warning Invisible laser radiation may be emitted from disconnected fibers or connectors. Do not stare into beams or view directly with optical instruments.

ステートメント 1051: レーザー放射



警告 接続されていない光ファイバケーブルやコネクタからは目に見えないレーザー光が放射されている可能性があります。レーザー光を直視したり、光学機器を使用して直接見たりしないでください。

Statement 1255—Laser Compliance Statement



Warning Pluggable optical modules comply with IEC 60825-1 Ed. 3 and 21 CFR 1040.10 and 1040.11 with or without exception for conformance with IEC 60825-1 Ed. 3 as described in Laser Notice No. 56, dated May 8, 2019.

聲明4011—國家通信委員會警告



警告

取得審驗證明之低功率射頻器材，非經核准，公司、商號或使用者均不得擅自變更頻率、加大功率或變更原設計之特性及功能。低功率射頻器材之使用不得影響飛航安全及干擾合法通信；經發現有干擾現象時，應立即停用，並改善至無干擾時方得繼續使用。前述合法通信，指依電信管理法規定作業之無線電通信。低功率射頻器材須忍受合法通信或工業、科學及醫療用電波輻射性電機設備之干擾。

Intended Use of equipment

The IR1800 Series provides radio slots to support multiple radio configurations based on use cases. Provisions to support PoE and xDSL WAN are included. The chassis is powered directly off 12 to 24VDC vehicle-charging systems or an external power source. The IR1800 Series can be used indoors or outdoors, as allowed by regulations.

Changing Output Power

Changing the power output is allowed only by a trained service professional.

Obtaining Documents from Cisco.com

Follow these steps to obtain any of the online documents mentioned in this document.

- For Cisco IR1800 Series products, go [here](#).
- If you still have questions regarding the compliance of these products, or you cannot find the information you are looking for, send an email to Cisco at complianceinfo@cisco.com.

