



Cisco ASR 1009-X Router and Cisco ASR 1006-X Hardware Installation Guide

First Published: 2013-08-02

Last Modified: 2016-11-18

Americas Headquarters

Cisco Systems, Inc.
170 West Tasman Drive
San Jose, CA 95134-1706
USA
<http://www.cisco.com>
Tel: 408 526-4000
800 553-NETS (6387)
Fax: 408 527-0883



CONTENTS

PREFACE

| | |
|--|------------|
| Preface | vii |
| Document Revision History | vii |
| Document Objectives | vii |
| Audience | vii |
| Document Organization | viii |
| Conventions | viii |
| Related Documentation | x |
| Obtaining Documentation and Submitting a Service Request | x |

CHAPTER 1

| | |
|---|----------|
| Cisco ASR 1009-X Router and Cisco ASR 1006-X Router Overview | 1 |
| Overview | 1 |
| Cisco ASR 1009-X Router | 1 |
| Hardware Features of the Cisco ASR 1009-X Router | 1 |
| Cisco ASR 1009-X Overall Chassis Front View | 2 |
| Cisco ASR 1009-X Chassis Rear View | 3 |
| Cisco ASR 1006-X Router | 4 |
| Hardware Features of the Cisco ASR 1006-X Router | 4 |
| Cisco ASR 1006-X Overall Chassis Front View | 5 |
| Cisco ASR 1006-X Chassis Rear View | 6 |
| Field-Replaceable Units for the Cisco ASR 1009-X Router and Cisco ASR 1006-X Router | 6 |
| Cisco Product Identification Standard | 7 |
| Unique Device Identifier | 7 |
| Serial Number and PID/VID Label Location | 9 |

CHAPTER 2

| | |
|--|-----------|
| Cisco ASR 1009-X Router and Cisco ASR 1006-X Router Supported Hardware Components | 13 |
| Supported Hardware Components | 13 |

Supported SPAs 14
 Supported Line Cards 16
 Supported EPAs 16
 Supported NIMs 17

CHAPTER 3

Cisco ASR 1009-X Router and Cisco ASR 1006-X Router Power Supply 19
 Power Supplies for the Cisco ASR 1009-X Router and Cisco ASR 1006-X Router 19
 Cisco ASR 1009-X Router and Cisco ASR 1006-X Router Power Supply Fans 20
 Cisco ASR1000X-AC-1100W AC Power Supply 21
 Cisco ASR1000X-DC-950W DC Power Supply 22
 Cisco ASR 1009-X Router and Cisco ASR 1006-X Router Power Supply LEDs 22
 Power Cords Supported by the Cisco ASR1000X-AC-1100W Power Supply 23
 System Power Management 24
 Power Management Policies 24
 N+1 Power Redundancy Policies 24
 Show Platform Power Information 25
 System Power Management Log Messages 26

CHAPTER 4

Preparing Your Site for Installation 27
 Prerequisites and Preparation 27
 Site Planning Checklist 28
 Safety Guidelines 28
 Safety Warnings 28
 Safety Recommendations 29
 Compliance Requirements 29
 Cautions and Regulatory Compliance Statements for NEBS 30
 Standard Warning Statements 31
 General Safety Warnings 31
 Site Planning 34
 General Precautions 34
 Site Selection Guidelines 35
 Site Environmental Requirements 35
 Physical Characteristics 36
 Site Power Guidelines 37

| | |
|--|--|
| Electrical Circuit Requirements | 37 |
| Site Cabling Guidelines | 38 |
| Console Port Connections | 39 |
| Interference Considerations | 39 |
| Electromagnetic Interference | 39 |
| Radio Frequency Interference | 40 |
| Lightning and AC Power Fault Interference | 40 |
| Rack-Mounting Guidelines | 40 |
| Precautions for Rack-Mounting | 41 |
| General Rack Selection Guidelines | 41 |
| Guidelines for 23 in. (Telco) Racks | 41 |
| Equipment Rack Guidelines | 42 |
| Preventing Electrostatic Discharge Damage | 42 |
| Electrical Safety | 43 |
| Chassis-Lifting Guidelines | 44 |
| Tools and Equipment | 45 |
| Unpacking and Verifying Shipping Contents | 45 |
| Checking the Shipping Container Contents | 46 |
| Cisco ASR 1000 Series Router Installation Checklist | 47 |
| <hr/> | |
| CHAPTER 5 | Cisco ASR 1009-X Router and Cisco ASR 1006-X Router Installation 49 |
| Installation Methods | 49 |
| General Rack Installation Guidelines | 50 |
| Guidelines for Equipment Rack Installation | 50 |
| Attaching the Rear Rack-Mount Brackets | 51 |
| Rack-Mounting the Cisco ASR 1009-X Router and Cisco ASR 1006-X Router | 53 |
| Verifying Rack Dimensions | 53 |
| Installing the Cisco ASR 1009-X Router and Cisco ASR 1006-X Router in a Rack | 54 |
| Installing the Chassis Using the Forward Rack-Mount Brackets | 54 |
| Installing the Chassis Using the Rear Rack-Mount Brackets | 56 |
| Two-Post Rack Installation | 57 |
| Four-Post Rack Installation | 58 |
| Attaching the Cable-Management Bracket | 60 |

Attaching the Chassis Ground Connection for Cisco ASR 1006-X Router and Cisco ASR 1009-X Router 61

Connecting the Shared Port Adapter Cables 64

Connecting the Console and Auxiliary Port Cables 64

Connecting the Ethernet Management Port 65

Connecting Power to the Cisco ASR 1009-X Router and Cisco ASR 1006-X Router 66

 Connecting AC Input Power to Cisco ASR 1009-X Router and Cisco ASR 1006-X Router 66

 Connecting DC Input Power to Cisco ASR 1009-X Router and Cisco ASR 1006-X Router 67

Connecting a Terminal to the Cisco ASR 1000 Series RP Console Port 70

Connecting the System Cables 71

CHAPTER 6

Cisco ASR 1009-X Router and Cisco ASR 1006-X Router Power Up and Initial Configuration 73

Checking Conditions Prior to System Startup 73

Powering Up the Cisco ASR 1009-X Router or Cisco ASR 1006-X Router 74

Verifying Power Supply Operation 77

 Verifying the Front Panel LEDs 78

 Verifying the Hardware Configuration 78

 Checking Hardware and Software Compatibility 78

Configuring the Cisco ASR 1009-X Router or Cisco ASR 1006-X Router at Startup 79

 Using the Console Interface 79

 Configuring Global Parameters 80

 Checking the Running Configuration Settings 81

 Saving the Running Configuration to NVRAM 81

Powering Off the Cisco ASR 1009-X Router or Cisco ASR 1006-X Router Safely 81

CHAPTER 7

Removing and Replacing Cisco ASR 1009-X Router and Cisco ASR 1006-X Router FRUs 83

Removing and Replacing Power Supplies 83

 Removing AC Power Supplies 84

 Installing AC Power Supplies 85

 Removing DC Input Power Supplies 85

 Installing DC Input Power Supplies 86

 Wiring the DC Input Power Source 87

Removing and Replacing Fans 89



Preface

This preface contains the following topics:

- [Document Revision History, on page vii](#)
- [Document Objectives, on page vii](#)
- [Audience, on page vii](#)
- [Document Organization, on page viii](#)
- [Conventions, on page viii](#)
- [Related Documentation, on page x](#)
- [Obtaining Documentation and Submitting a Service Request, on page x](#)

Document Revision History

The following table describes the chapters in this installation guide:

| Date | | Change Summary |
|------|----------------|--------------------------------|
| 1 | September 2015 | First version of the document. |
| 2 | November 2016 | Template update. |

Document Objectives

This publication describes the installation of a Cisco ASR 1009-X Router and Cisco ASR 1006-X Router, and replacement or upgrade of field-replaceable units (FRUs). The purpose of this guide is to enable the safe and efficient installation of the Cisco ASR 1009-X Router and Cisco ASR 1006-X Router.

Audience

This publication is primarily designed for persons responsible for installing, maintaining, and troubleshooting the Cisco ASR 1000 Series Aggregation Services Routers. The users of this guide should:

- Be familiar with electronic circuitry and wiring practices.
- Have experience working as electronic or electromechanical technicians.

- Have experience in installing high-end networking equipment.



Note Certain procedures described in this guide require a certified electrician.

Document Organization

The following table describes the chapters in this installation guide:

| Chapter and Appendix | | Description |
|----------------------|--|--|
| 1 | Cisco ASR 1009-X Router and Cisco ASR 1006-X Router Overview | Provides an overview of the Cisco ASR1006-X Router and Cisco ASR1009-X Router. |
| 2 | Cisco ASR 1009-X Router and Cisco ASR 1006-X Router Supported Hardware Components | Provides an overview of the hardware components for the Cisco ASR1006-X Router and Cisco ASR1009-X Router. |
| 3 | Cisco ASR 1009-X Router and Cisco ASR 1006-X Router Power Supply | Provides information about the power supplies that are supported on the Cisco ASR1006-X Router and Cisco ASR1009-X Router. |
| 4 | Preparing Your Site for Installation | Provides site preparation guidelines for installing the Cisco ASR 1009-X Router and Cisco ASR 1006-X Router. |
| 5 | Cisco ASR 1009-X Router and Cisco ASR 1006-X Router Installation | Provides information about the installation methods and steps to install the Cisco ASR 1009-X Router and Cisco ASR 1006-X Router. Provides basic system startup and initial configuration information |
| 6 | Cisco ASR 1009-X Router and Cisco ASR 1006-X Router Power Up and Initial Configuration | Provides basic system startup and initial configuration information. |

Conventions

| Text Type | Indication |
|-----------------|--|
| User input | Text the user should enter exactly as shown or keys a user should press appear in this font . |
| Document titles | Document titles appear in <i>this font</i> . |
| System output | Terminal sessions and information that the system displays appear in <i>this font</i> . |

| Text Type | Indication |
|--------------|---|
| CLI commands | CLI command keywords appear in this font . Variables in a CLI command appear in <i>this font</i> . |
| [] | Elements in square brackets are optional. |
| {x y z} | Required alternative keywords are grouped in braces and separated by vertical bars. |
| [x y z] | Optional alternative keywords are grouped in brackets and separated by vertical bars. |
| string | A nonquoted set of characters. Do not use quotation marks around the string or the string will include the quotation marks. |
| < > | Nonprinting characters such as passwords are in angle brackets. |
| [] | Default responses to system prompts are in square brackets. |
| ! # | An exclamation point (!) or a pound sign (#) at the beginning of a line of code indicates a comment line. |



Note Means *reader take note*. Notes contain helpful suggestions or references to material not covered in the document.



Tip Means *the following information will help you solve a problem*. The tips information might not be troubleshooting or even an action, but could be useful information, similar to a Timesaver.



Caution Means *reader be careful*. In this situation, you might perform an action that could result in equipment damage or loss of data.



Timesaver Means *the described action saves time*. You can save time by performing the action described in the paragraph.



Warning IMPORTANT SAFETY INSTRUCTIONS

This warning symbol means danger. You are in a situation that could cause bodily injury. Before you work on any equipment, be aware of the hazards involved with electrical circuitry and be familiar with standard practices for preventing accidents. Use the statement number provided at the end of each warning to locate its translation in the translated safety warnings that accompanied this device.

SAVE THESE INSTRUCTIONS

Related Documentation

See the following documents:

- [Documentation Roadmap for Cisco ASR 1000 Series, Cisco IOS XE Denali 16.x](#)—Provides links to all Cisco ASR 1000 Series product documentation.
- [Cisco ASR 1000 Route Processor 3 Installation and Configuration Guide](#)—Describes how to install and configure the Cisco ASR1000-RP3 module.

Obtaining Documentation and Submitting a Service Request

For information on obtaining documentation, submitting a service request, and gathering additional information, see the monthly [What's New in Cisco Product Documentation](#), which also lists all new and revised Cisco technical documentation.

Subscribe to the *What's New in Cisco Product Documentation* as a Really Simple Syndication (RSS) feed and set content to be delivered directly to your desktop using a reader application. The RSS feeds are a free service and Cisco currently supports RSS version 2.0.



CHAPTER 1

Cisco ASR 1009-X Router and Cisco ASR 1006-X Router Overview

This chapter contains the following topics:

- [Overview, on page 1](#)
- [Cisco ASR 1009-X Router, on page 1](#)
- [Cisco ASR 1006-X Router, on page 4](#)
- [Field-Replaceable Units for the Cisco ASR 1009-X Router and Cisco ASR 1006-X Router, on page 6](#)
- [Cisco Product Identification Standard, on page 7](#)
- [Serial Number and PID/VID Label Location, on page 9](#)

Overview

The Cisco ASR 1000 Series Aggregation Services Routers are mid-range edge routers that establish a new price-to-performance class offering benefits to both enterprise and service providers alike. The Cisco ASR 1000 Series Aggregation Services Routers portfolio is based on an innovative custom-built ASIC called Quantum Flow Processor that aggregates services at scale.

The Cisco ASR1006-X Router and Cisco ASR1009-X Router create a future-proof modular routing platform to support next generation Forwarding and Route Processor modules with hardware redundancy. The Cisco ASR1006-X Router and Cisco ASR1009-X Router provide up to 200 Gbps slot bandwidth to enable new high density Ethernet linecards utilizing the ASR1000-MIP100 and Ethernet Port Adapters (EPAs), and integrating N+1 power-on-demand design to the ASR1000 portfolio.

Cisco ASR 1009-X Router

Hardware Features of the Cisco ASR 1009-X Router

The Cisco ASR 1009-X Router supports:

- 9 Rack Units and 3-line card slot chassis with redundant slots for forwarding and route processor boards
- ASR1000-RP2 module, future next generation ASR1000-RP3 module, and ASR1000-ESP200, ASR1000-ESP100, and ASR1000-ESP40 engines



Note For information about the Cisco ASR1000-RP3 module, see the [Cisco ASR 1000 Route Processor 3 Installation and Configuration Guide](#).

- Provides investment protection to support existing forwarding processor (ESP40, ESP100, and ESP200)
- Provides future proof to support future next generation forwarding processor
- 100 Gbps high density, modular Ethernet linecards (ASR1000 MIP-100)
- Three linecard slots support any of the following combinations:
 - ASR1000-SIP40 with SPA
 - Ethernet linecard (ASR1000-6TGE and ASR1000-2T+20x1GE)
 - ASR1000-MIP100 with EPA
- New common fan modules to provide up to 30% better cooling for the chassis. Three fan modules per chassis
- New power supplies are introduced for the chassis to provide greater power
- Power-on-demand design with N+1 power redundancy to meet any current and future power demand
- Up to six AC or six DC power supplies that are aligned along the bottom of the chassis (power shelf)

Cisco ASR 1009-X Overall Chassis Front View

The following figure shows the front of the Cisco ASR 1009-X Router.

Figure 1: Cisco ASR 1009-X Router Front View

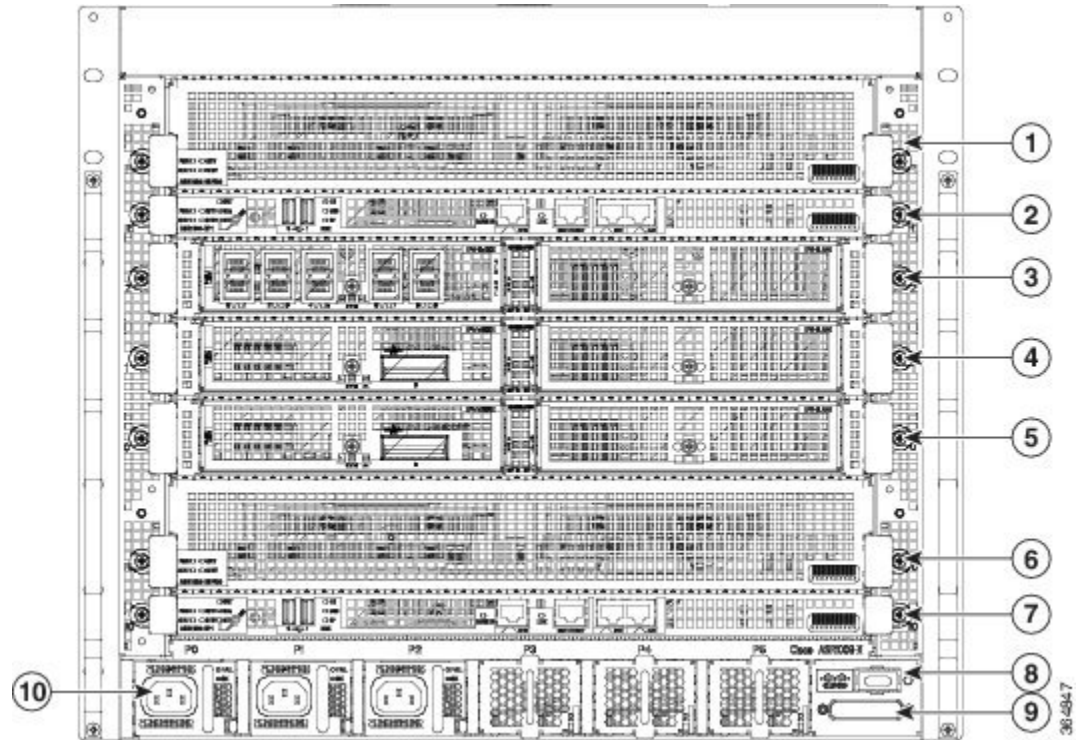

| | | | |
|---|---------|----|---|
| 1 | Slot F1 | 6 | Slot F0 |
| 2 | Slot R1 | 7 | Slot R0 |
| 3 | Slot 2 | 8 | Standby/ON switch |
| 4 | Slot 1 | 9 | DB-25 Alarm connector |
| 5 | Slot 0 | 10 | Power shelf that has power supplies from P0 to P5 |



Note The Cisco ASR1009-X Router can support up to six AC or six DC power supplies. The chassis does not support mixed AC and DC configuration

Cisco ASR 1009-X Chassis Rear View

The following figure shows the rear of the Cisco ASR 1009-X chassis with three fan modules and associated LEDs.

Figure 2: Cisco ASR 1009-X Router Rear View

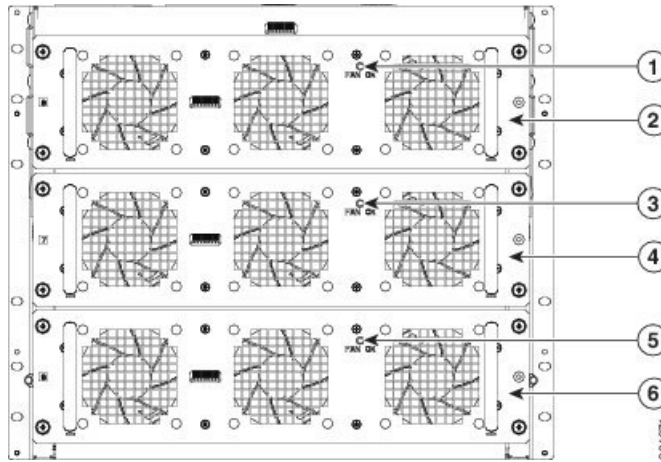

| | | | |
|---|-------------------------|---|-------------------------|
| 1 | Fan Module 8 Status LED | 4 | Fan Module 7 |
| 2 | Fan Module 8 | 5 | Fan Module 6 Status LED |
| 3 | Fan Module 7 Status LED | 6 | Fan Module 6 |



Note The FAN OK LED can have three colors: Green, Red, and Amber. Green indicates Good, Red indicates Failed, and Amber indicates a Warning condition, when one or more fans may be operating at less than the expected speed, but not slow enough to call it a failure.

See the [Cisco ASR 1009-X Router and Cisco ASR 1006-X Router Power Supply LEDs, on page 22](#) section for more details.

Cisco ASR 1006-X Router

Hardware Features of the Cisco ASR 1006-X Router

The Cisco ASR 1006-X Router supports:

- 6 Rack Units and 2-line card slot chassis with redundant slots for forwarding and route processor boards
- ASR1000-RP2 module, future next generation ASR1000-RP3 module, and ASR1000-ESP40 and ASR1000-ESP100 engines.



Note For information about the Cisco ASR1000-RP3 module, see the [Cisco ASR 1000 Route Processor 3 Installation and Configuration Guide](#).

- Provides investment protection to support existing forwarding processor (ESP40 and ESP100)

- Provides future proof to support future next generation forwarding processor.
- 100 Gbps high density, modular Ethernet linecards (ASR1000-MIP100)
- Two linecard slots support any of the following combinations:
 - ASR1000-SIP40 with SPA
 - Ethernet linecard (ASR1000-6TGE and ASR1000-2T+20x1GE)
 - ASR1000-MIP100 with EPA
- New common fan modules to provide up to 30% better cooling for the chassis. Two fan modules per chassis.
- New power supplies are introduced for the chassis to provide greater power
- Power-on-demand design with N+1 power redundancy to meet any current and future power demand.
- Up to six AC or six DC power supplies that are aligned along the bottom of the chassis (power shelf)

Cisco ASR 1006-X Overall Chassis Front View

The following figure shows the front of the Cisco ASR 1006-X Router.

Figure 3: Cisco ASR 1006-X Router Front View

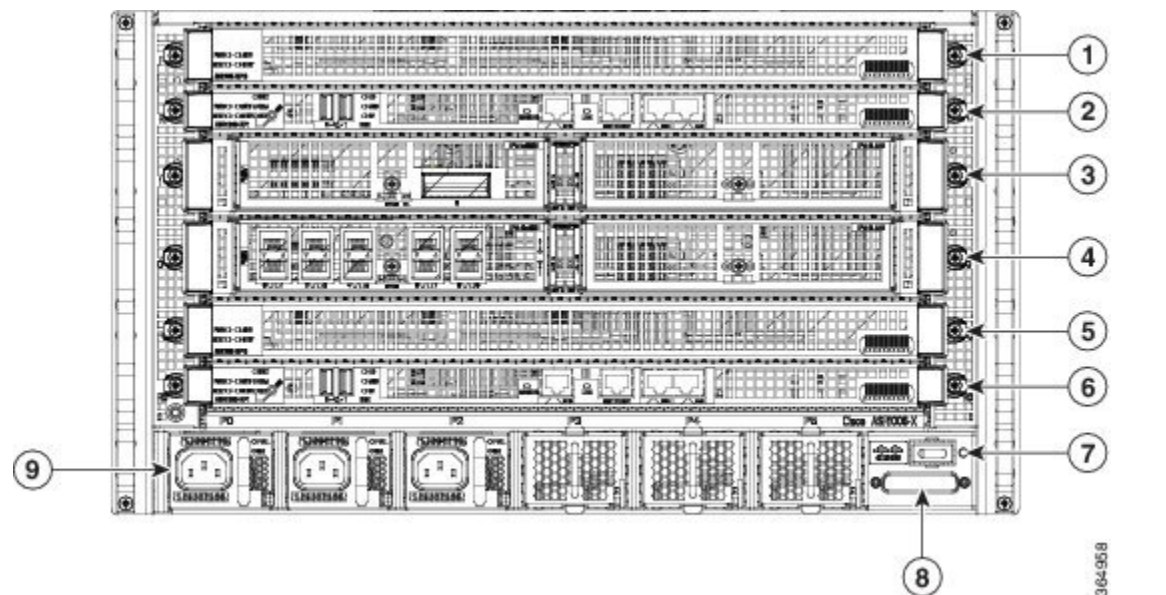

| | | | |
|---|---------|---|---|
| 1 | Slot F1 | 6 | Slot R0 |
| 2 | Slot R1 | 7 | Standby/ON switch |
| 3 | Slot 1 | 8 | DB-25 Alarm Connector |
| 4 | Slot 0 | 9 | Power shelf that has power supplies from P0 to P5 |

| | | | |
|---|---------|--|--|
| 5 | Slot F0 | | |
|---|---------|--|--|



Note The Cisco ASR 1006-X Router can support up to six AC or six DC power supplies. The chassis does not support mixed AC and DC configuration.

Cisco ASR 1006-X Chassis Rear View

The following figure shows the rear of the Cisco ASR 1006-X Router with two fan modules and associated LEDs.

Figure 4: Cisco ASR 1006-X Router Rear View

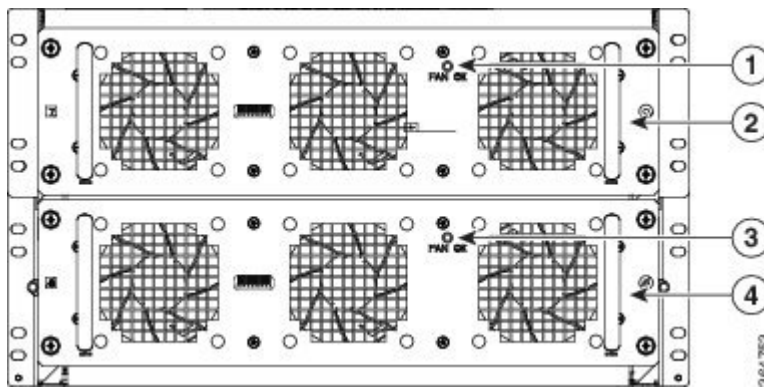

| | | | |
|---|-------------------------|---|-------------------------|
| 1 | Fan Module 7 Status LED | 3 | Fan Module 6 Status LED |
| 2 | Fan Module 7 | 4 | Fan Module 6 |



Note The FAN OK LED can have three colors: Green, Red, and Amber. Green indicates Good, Red indicates Failed, and Amber indicates a Warning condition, when one or more fans may be operating at less than the expected speed, but not slow enough to call it a failure.

See the [Cisco ASR 1009-X Router and Cisco ASR 1006-X Router Power Supply LEDs, on page 22](#) section for more details.

Field-Replaceable Units for the Cisco ASR 1009-X Router and Cisco ASR 1006-X Router

The Cisco ASR 1009-X Router and Cisco ASR 1006-X Router has a number of FRUs. These include:

- Route Processors
- Forwarding Processors

- Line Cards
- SPAs
- EPAs
- AC and DC power supplies
- Fan modules



Note For information about the Cisco ASR1000-RP3 module, see [Cisco ASR 1000 Route Processor 3 Installation and Configuration Guide](#).

Cisco Product Identification Standard

This section describes the Cisco products and services product identification standard. This feature provides you with the ability to effectively integrate and manage Cisco products in your network and business operations.

Unique Device Identifier

The Unique Device Identifier (UDI) is the Cisco product identification standard for hardware products. A product identification standard removes barriers to enterprise automation and can help you reduce operating expenses.

The UDI provides a consistent electronic, physical, and associated business-to-business information product identification standard.

The UDI is a combination of five data elements. The following table lists the UDI elements.

Table 1: UDI Elements

| UDI Data Element | Electronic Visibility | Physical Visibility | Description |
|---------------------|-----------------------|---------------------|--|
| PID | Yes | Yes | Product ID, also known as product name, model name, product number |
| VID | Yes | Yes | Version ID |
| SN | Yes | Yes | Serial number, the unique instance of the PID |
| Entity Name | Yes | — | Type, such as chassis, slot, or power supply |
| Product Description | Yes | — | Additional product information |

The combination of serial number and product ID (PID) is unique and consistent across all Cisco products. The PID that is coded on hardware is called a base product identifier.

Additional orderable PIDs can be associated to a base PID. For instance, an orderable PID may describe a packaging configuration for a product or a bundled group of products sold, tested, and shipped together. Specific unique device identifier (UDI) benefits include the following:

- Identifies:
 - Individual Cisco products in your networks
 - PIDs and serial numbers for service and replaceable products
 - Version IDs (VIDs) for product version visibility
- Facilitates discovery of products subject to recall or upgrade
- Enhances inventory automation of Cisco products

The Cisco product identification standard provides the following features:

- Version visibility—Cisco continuously improves products through feature additions. Product changes are indicated by incrementing the VID, which provides version visibility to help you understand and manage product changes. VID management ensures consistency of changes from product to product.
- Operating expense reduction—Cisco UDIs provide accurate and detailed network inventory information; identifying each Cisco product in a network element through a standard interface. Cisco operating systems can view and use this data, allowing you to automate your electronic inventory.
- Consistency across product layers—The UDIs are embedded in the hardware products and cannot be overwritten. Operating and management systems discover UDIs through standard interfaces and display UDIs in standard outputs. Standard interfaces include the IETF standard ENTITY-MIB.

The **show diag chassis eeprom detail** command displays the PID, VID, PCB serial number, hardware revision, and other such information.

The following is sample output from the **show diag chassis eeprom detail** command:

```
ASR1009-X-2#show diag chassis eeprom detail
MIDPLANE EEPROM data:

EEPROM version           : 4
Compatible Type          : 0xFF
Controller Type          : 3172
Hardware Revision        : 0.2
PCB Part Number          : 73-16095-02
Board Revision           : 01
Deviation Number         : 0-0
Fab Version              : 01
PCB Serial Number        : FXS1842043H
RMA Test History         : 00
RMA Number               : 0-0-0-0
RMA History              : 00
Top Assy. Part Number    : 68-5423-01
CLEI Code                : SAMPL00XYZ
Product Identifier (PID) : ASR1009-X
Version Identifier (VID) : V00
Chassis MAC Address      : 0c09.2a0f.0000
MAC Address block size   : 320
Chassis Serial Number    : FXS1845Q1QT
Asset ID                 :
Vendor ID                : 00
Environment Monitor Data : 00 08 00 F8
```

```
Environment Monitor Data : 04 11 DF 00 0C
```

```
ASR1006-X-1#sho diag chassis eeprom detail
MIDPLANE EEPROM data:
```

```
EEPROM version           : 4
Compatible Type          : 0xFF
Controller Type          : 3171
Hardware Revision        : 0.2
PCB Part Number          : 73-16102-03
Board Revision           : 01
Deviation Number         : 0-0
Fab Version              : 01
PCB Serial Number        : FXS1842046Z
RMA Test History         : 00
RMA Number               : 0-0-0-0
RMA History              : 00
Top Assy. Part Number    : 68-5481-01
CLEI Code                : SAMPL00XYZ
Product Identifier (PID) : ASR1006-X
Version Identifier (VID) : V00
Chassis MAC Address      : 0c06.2a0e.0000
MAC Address block size   : 256
Chassis Serial Number    : FXS1846Q415
Asset ID                 :
Vendor ID                : 00
Environment Monitor Data : 00 08 00 F8
Environment Monitor Data : 04 0F BE 00 2F
```



Note Common Language Equipment Identification (CLEI) code is a ten-digit character code that identifies a specific product. A CLEI code is applied to each part within a Cisco ASR 1009-X Router or Cisco ASR 1006-X Router as they are programmed in manufacturing for shipment to customers.



Note For complete information on the product identification standard, see <http://www.cisco.com/go/udi/>.

Serial Number and PID/VID Label Location

The following figure shows a Cisco ASR 1009-X Router along with the location of the serial number and the PID/VID label.

Figure 5: Cisco ASR 1009-X Router Serial Number and PID/VID Label Location

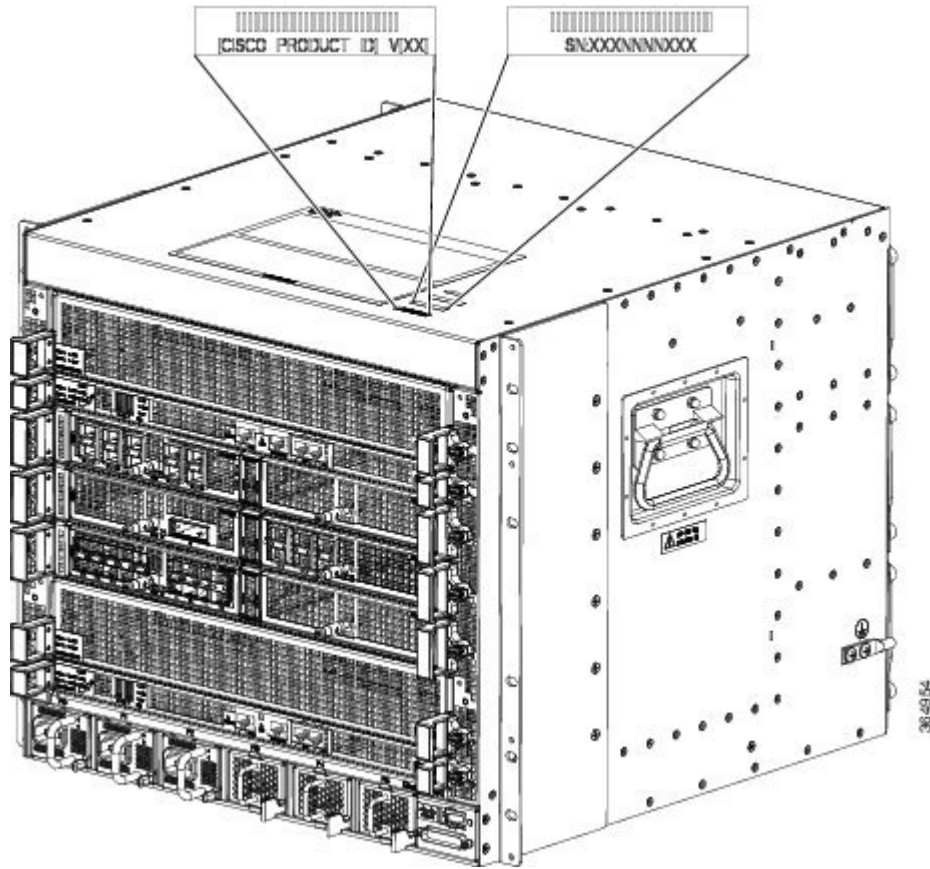

The following figure shows a Cisco ASR 1006-X Router along with the location of the serial number and the PID/VID label.

Figure 6: Cisco ASR 1006-X Router Serial Number and PID/VID Label Location

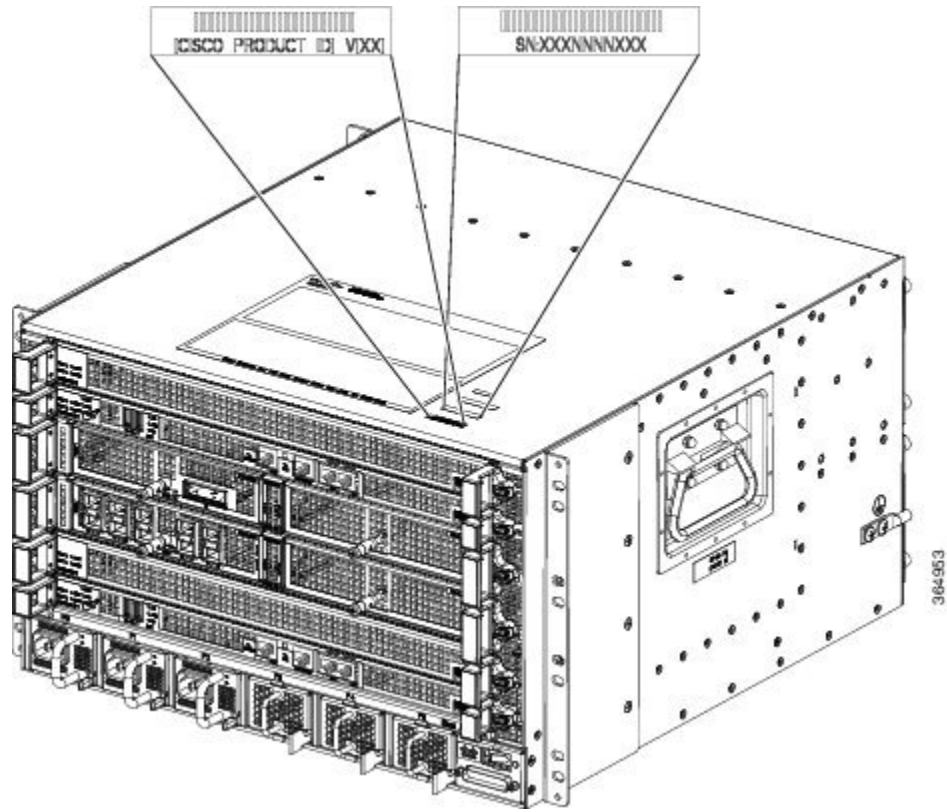



CHAPTER 2

Cisco ASR 1009-X Router and Cisco ASR 1006-X Router Supported Hardware Components

This chapter contains the following topics:

- [Supported Hardware Components, on page 13](#)
- [Supported SPAs, on page 14](#)
- [Supported Line Cards, on page 16](#)
- [Supported EPAs, on page 16](#)
- [Supported NIMs, on page 17](#)

Supported Hardware Components

The following table lists the hardware components supported on the Cisco ASR 1009-X Router and Cisco ASR 1006-X Router.

Table 2: Supported Hardware Components

| Chassis PID | ASR1006-X | ASR1009-X |
|-------------|---|---|
| Height | 6RU | 9RU |
| RP Slots | 2 | 2 |
| ESP Slots | 2 (regular) ¹ | 2 (super) ² |
| SIP Slots | 2 | 3 |
| SPA Slots | Up to 8 SPA slots are supported with SIP40 linecards | Up to 12 SPA Slots are supported with SIP40 linecards |
| EPA Slots | Up to 4 EPA slots are supported with MIP100 linecards | Up to 6 EPA slots are supported with MIP100 linecards |
| NIM Slots | NA | NA |
| Built-in GE | NA | NA |

| Chassis PID | ASR1006-X | ASR1009-X |
|--|--|---|
| Maximum number of Power Supplies supported/PID | Six ASR1000X-AC-1100W Six ASR1000X-DC-950W | Six ASR1000X-AC-1100W Six ASR1000X-DC-950W |
| RP | RP2 requires CPLD upgrade ³ | RP2 requires CPLD upgrade ⁴ |
| ESP | ASR1000-ESP40, ASR1000-ESP100,ASR1000-ESP100-X, ASR1000-ESP200-X | ASR1000-ESP40, ASR1000-ESP100, ASR1000-ESP200, ASR1000-ESP100-X, ASR1000-ESP200-X |
| Line Cards | ASR1000-2T+20X1GE, ASR1000-6TGE, ASR1000-MIP100, and ASR1000-SIP40 | ASR1000-2T+20X1GE, ASR1000-6TGE, ASR1000-MIP100, and ASR1000-SIP40 |
| Fan Modules/PID | Two ASR1000X-FAN | Three ASR1000X-FAN |

¹ Regular slot supports ASR1000-ESP40, ASR1000-ESP100, ASR1000-ESP100-X, and ASR1000-ESP200-X.

² Super slot supports ASR1000-ESP40, ASR1000-ESP100, ASR1000-ESP200, and 400Gbps capable for future generation forwarding engine.

³ The minimum CPLD version must be 0x14111801 or greater for RP2 to be used in the Cisco ASR 1009-X Router or Cisco ASR 1006-X Router. See CPLD upgrade section for further details.

⁴ The minimum CPLD version must be 0x14111801 or greater for RP2 to be used in the Cisco ASR 1009-X Router or Cisco ASR 1006-X Router. See CPLD upgrade section for further details.

Supported SPAs

The following table lists the supported SPAs on the Cisco ASR 1009-X Router and Cisco ASR 1006-X Router.

Table 3: Supported SPAs

| PID | Description |
|-------------------|---|
| SPA-1X10GE-L-V2 | Cisco 1-Port 10GE LAN-PHY |
| SPA-1XCHSTM1/OC3 | 1-port Channelized STM-1/OC-3c to DS0 |
| SPA-1XOC12-POS | 1-port OC12/STM4 POS |
| SPA-8XCHT1/E1-V2 | 8-port Channelized T1/E1 to DS0 Shared Port Adapter |
| SPA-1CHSTM1/OC3V2 | SPA-1CHSTM1/OC3V2 |
| SPA-2XCT3/DS0-V2 | 2-port Channelized T3 to DS0 Shared Port Adapter, Version 2 |
| SPA-2XT3/E3-V2 | 2-port Clear Channel T3/E3 Shared Port Adapter, Version 2 |
| SPA-4XCT3/DS0-V2 | 4-port Channelized T3 to DS0 Shared Port Adapter, Version 2 |
| SPA-4XT3/E3-V2 | 4-port Clear Channel T3/E3 Shared Port Adapter, Version 2 |
| SPA-2XOC48POS/RPR | 2-port OC48/STM16 POS/RPR Shared Port Adapters |

| PID | Description |
|-------------------|--|
| SPA-2XOC12-POS | 2-port OC12/STM4 POS |
| SPA-4XOC12-POS | 4-port OC-12/STM-4 POS |
| SPA-1XOC12-POS-V2 | SPA-2XOC12-POS with a license to use 1 port |
| SPA-2XOC3-POS-V2 | SPA-4XOC3-POS-V2 with a license to use 2 ports |
| SPA-8XOC12-POS | 8-port OC12/STM4 |
| SPA-1XOC3-ATM-V2 | 1-port OC-3c/STM-1 ATM |
| SPA-2X1GE-V2 | Cisco 2-Port Gigabit Ethernet |
| SPA-2XCT3/DS0 | 2-port Channelized T3 to DS0 |
| SPA-2XOC3-POS | 2-port OC3/STM1 POS |
| SPA-8XOC3-POS | 8-port OC-3/STM-1 POS |
| SPA-1XOC48POS/RPR | 1-port OC48/STM16 POS/RPR |
| SPA-10X1GE-V2 | Cisco 10-Port Gigabit Ethernet Shared Port Adapter |
| SPA-1CHOC3-CE-ATM | 1 Port Channelized OC3/STM-1 ATM and Circuit Emulation SPA |
| SPA-2XT3/E3 | 2-port Clear Channel T3/E3 |
| SPA-3XOC3-ATM-V2 | 3-port OC-3c/STM-1 ATM |
| SPA-4X1FE-TX-V2 | Cisco 4-Port Fast Ethernet (TX) |
| SPA-4XCT3/DS0 | 4-port Channelized T3 to DS0 |
| SPA-4XOC3-POS | 4-port OC3/STM1 POS |
| SPA-4XOC48POS/RPR | 4-port OC48/STM16 POS/RPR Shared Port Adapters |
| SPA-OC192POS-XFP | 1-port OC192/STM64 POS/RPR XFP Optics |
| SPA-4XT-SERIAL | Cisco 4-port serial SPA |
| SPA-4XT3/E3 | 4-port Clear Channel T3/E3 |
| SPA-5X1GE-V2 | Cisco 5-Port Gigabit Ethernet |
| SPA-8X1FE-TX-V2 | Cisco 8-Port Fast Ethernet (TX) |
| SPA-8X1GE-V2 | Cisco 8-Port Gigabit Ethernet |
| SPA-8XCHT1/E1 | 8-port Channelized T1/E1 to DS0 |
| SPA-1XOC12-ATM-V2 | 1-port OC12 STM SPA |
| SPA-DSP | Digital Signal Processor SPA |

| PID | Description |
|-------------------|--|
| SPA-1X10GE-WL-V2 | Cisco 1-port 10GE LAN/WAN-PHY |
| SPA-1XCHOC12/DS0 | 1-port Channelized OC12 to DS0 SPA |
| SPA-2CHT3-CE-ATM | 2-Port Channelized T3/E3 ATM and Circuit Emulation SPA |
| SPA-4XOC3-POS-V2 | 4-port OC-3/STM-1 POS |
| SPA-2X1GE-SYNCE | Cisco Synchronous Ethernet SPA |
| SPA-8XT3/E3 | Cisco 8-Port Clear Channel T3/E3 Shared Port Adapter |
| SPA-24CHT1-CE-ATM | Cisco 24 Port T1/E1/J1 Circuit Emulation SPA |

Supported Line Cards

The following table lists the line cards supported on the Cisco ASR 1009-X Router and Cisco ASR 1006-X Router.

Table 4: Supported Line Cards

| PID | Description |
|-------------------|---|
| ASR1000-2T+20X1GE | Cisco ASR 1000 Series Fixed Ethernet Line Card, 2x10GE + 20x1GE |
| ASR1000-6TGE | Cisco ASR 1000 Series Fixed Ethernet Line Card, 6x10GE |
| ASR1000-MIP100 | Cisco ASR 1000 Series Modular Ethernet Line Card, 1x100GE |
| ASR1000-SIP40 | SIP40, 40 Gbps |



Note When utilizing ASR1000-MIP100 line card in Cisco ASR 1009-X Router or Cisco ASR 1006-X Router, ESP40 is not supported. Please verify that either ESP100 or ESP200 is installed when utilizing this line card.



Note For optimal installation performance when adding line cards to an empty chassis, it is recommended to load the bottom-most slot first and then progressively move upwards to load the remaining slots.

Supported EPAs

The following table lists the Ethernet Port Adapters (EPAs) supported on the Cisco ASR 1009-X Router and Cisco ASR 1006-X Router.

Table 5: Supported EPAs

| PID | Description |
|-------------|---------------------------------|
| EPA-1X100GE | 1-Port 100 Gigabit Ethernet EPA |
| EPA-10X10GE | 10-Port 10 Gigabit Ethernet EPA |

Supported NIMs

There are no supported Network Interface Modules (NIMs) on the Cisco ASR 1009-X Router and Cisco ASR 1006-X Router.



CHAPTER 3

Cisco ASR 1009-X Router and Cisco ASR 1006-X Router Power Supply

This chapter contains the following topics:

- [Power Supplies for the Cisco ASR 1009-X Router and Cisco ASR 1006-X Router, on page 19](#)
- [Cisco ASR 1009-X Router and Cisco ASR 1006-X Router Power Supply Fans, on page 20](#)
- [Cisco ASR1000X-AC-1100W AC Power Supply, on page 21](#)
- [Cisco ASR1000X-DC-950W DC Power Supply, on page 22](#)
- [Cisco ASR 1009-X Router and Cisco ASR 1006-X Router Power Supply LEDs, on page 22](#)
- [Power Cords Supported by the Cisco ASR1000X-AC-1100W Power Supply, on page 23](#)
- [System Power Management, on page 24](#)
- [Power Management Policies, on page 24](#)
- [N+1 Power Redundancy Policies, on page 24](#)
- [Show Platform Power Information, on page 25](#)
- [System Power Management Log Messages, on page 26](#)

Power Supplies for the Cisco ASR 1009-X Router and Cisco ASR 1006-X Router

Each Cisco ASR 1009-X Router and Cisco ASR 1006-X Router power supply provides up to 1100 W of output power. The power supplies are used in an N + 1 redundant configuration. There is no input switch on the faceplate of the power supplies. All installed power supplies are switched from Standby to On by way of a system chassis ON/OFF switch. When facing the front of the chassis, power supply slot 0 (P0) is to the left and power supply slot 5 (P5) is to the right (next to the system ON/OFF switch and alarm contacts connector).

The Cisco ASR 1009-X Router and Cisco ASR 1006-X Router supports the following power supplies:

- Cisco ASR1000X-AC-1100W AC power supply—Provides 1100 W output power with DC voltage output of +12 V. The AC power supply operates between 90 and 264 VAC. The AC power supply current shares on the 12 V output and is used in a multiple hot-pluggable configuration.
- Cisco ASR1000X-DC-950W DC power supply—Provides 950 W output power with DC voltage output of +12 V. The power supply operates from –48 or –60 VDC. The DC power supply current shares on the 12 V output and is used in a multiple hot-pluggable configuration.



Note The Cisco ASR 1009-X Router and Cisco ASR 1006-X Router can support up to six AC 1100 W power supplies or six DC 950 W power supplies. The AC and DC power supplies cannot be mixed in a chassis.

The following figure shows a power supply module removed from the Cisco ASR 1009-X Router.

Figure 7: Power Supply Removed from Cisco ASR 1009-X Router

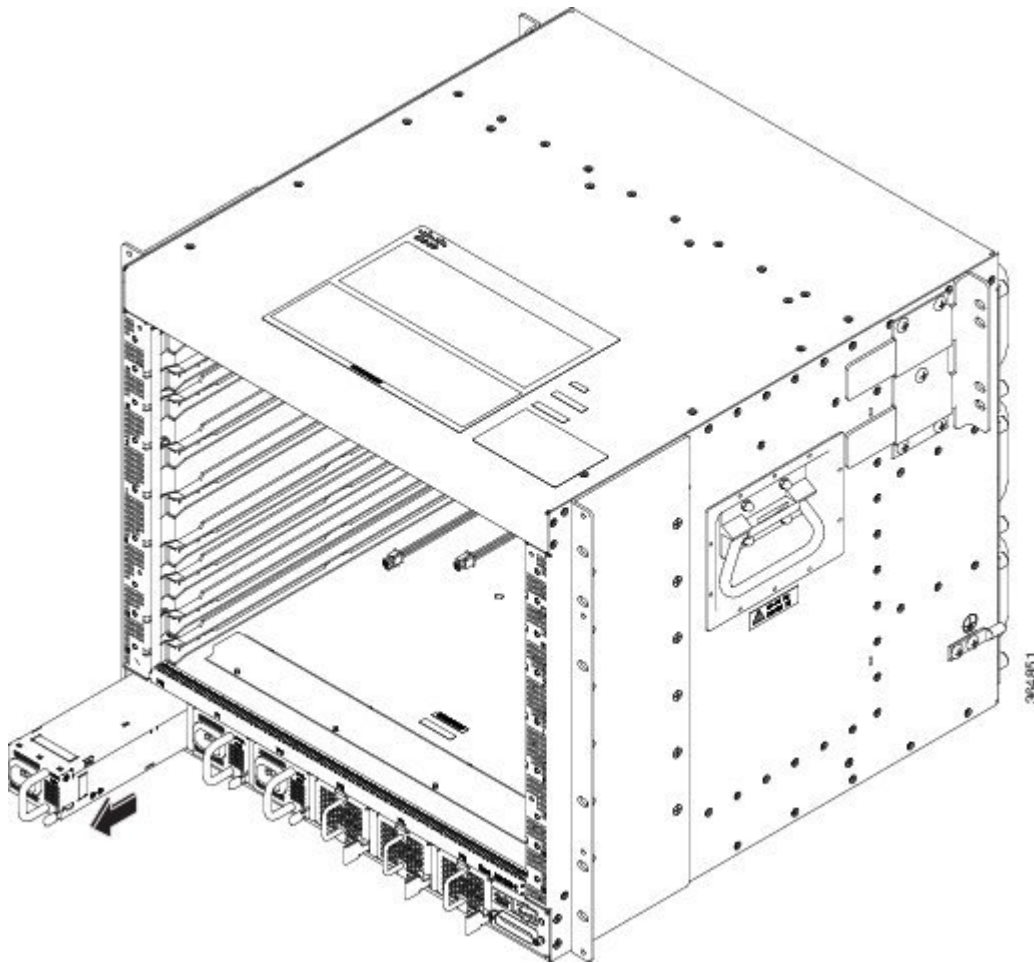

Cisco ASR 1009-X Router and Cisco ASR 1006-X Router Power Supply Fans

The fans in the power supply module of the Cisco ASR 1009-X Router and Cisco ASR 1006-X Router are used for cooling the power supply module itself while system-level cooling is provided by replaceable fan modules installed into the rear of the chassis. The power supplies do not depend on the system-level fans for cooling. Fan failure is determined by fan-rotation sensors.



Note The fans in the power supply modules may run as soon as the power supply is plugged in, even if the power switch is in the OFF position.

Cisco ASR1000X-AC-1100W AC Power Supply

The Cisco ASR 1009-X Router and Cisco ASR 1006-X Router have six slots within a power supply shelf located at the bottom of the chassis. The power supplies will typically be installed from left to right (slots 0-5) but can be supported in any configuration. See table below for supported power cords. At present, the potential power capability exceeds any load that can be placed on the chassis with currently supported FRUs. This allows significant freedom for installing spare supplies and allows for a software based N+1 configuration to warn of failed supply or oversubscribed power scenarios. See the chapter on Power Management for more information on N+1 and other power management support.

The input receptacle is an IEC60320 C14 type of filtered AC inlet. The current rating on the connector is 15 A. The following figure shows the Cisco ASR1000X-AC-1100W AC power supply.

Figure 8: Cisco ASR1000X-AC-1100W AC Power Supply

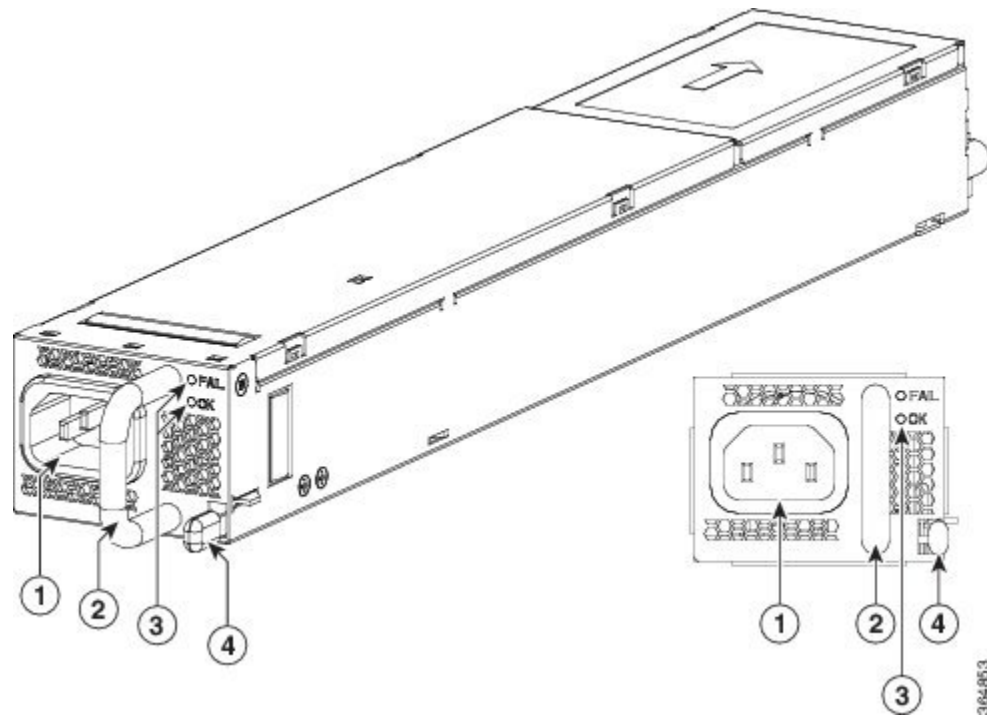

| | | | |
|---|--------------------|---|------------------|
| 1 | AC power connector | 3 | FAIL and OK LEDs |
| 2 | Handle | 4 | Retaining latch |

Cisco ASR1000X-DC-950W DC Power Supply

The Cisco ASR 1009-X Router and Cisco ASR 1006-X Router DC input connector is a two-wire connector with connection polarity from left to right (when facing the unit) of positive (+) negative (-).

The power supply has a handle to be used for insertion and extraction. The module must be supported with one hand because of its length. The following figure shows the Cisco ASR1000X-DC-950W DC power supply.

Figure 9: Cisco ASR1000X-DC-950W DC Power Supply

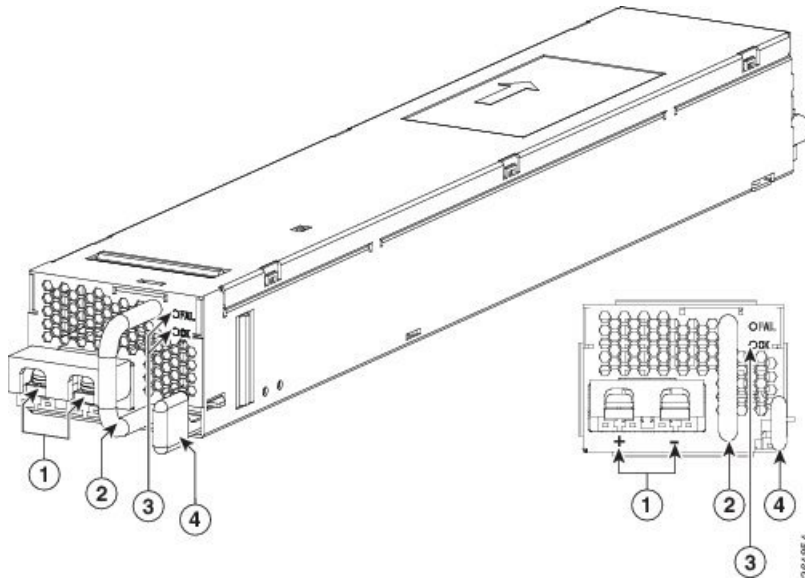

| | | | |
|---|----------------------|---|------------------|
| 1 | DC power connections | 3 | FAIL and OK LEDs |
| 2 | Handle | 4 | Retaining latch |

Cisco ASR 1009-X Router and Cisco ASR 1006-X Router Power Supply LEDs

The following table describes the Cisco ASR 1009-X Router and Cisco ASR 1006-X Router power supply LEDs.

Table 6: Cisco ASR 1009-X Router and Cisco ASR 1006-X Router—LED Indicators

| Power Supply Condition | Green (OK) LED Status | Amber (FAIL) LED Status |
|--|-----------------------|-------------------------|
| No AC power to all power supplies | OFF | OFF |
| Power Supply Failure (includes over voltage, over current, over temperature and fan failure) | OFF | ON |

| Power Supply Condition | Green (OK) LED Status | Amber (FAIL) LED Status |
|---|-----------------------|-------------------------|
| Power Supply Warning events where the power supply continues to operate (high temperature, high power and slow fan) | OFF | 1Hz Blinking |
| AC Present/3.3VSB on (PSU OFF) | 1Hz Blinking | OFF |
| Power Supply ON and OK | ON | OFF |

Power Cords Supported by the Cisco ASR1000X-AC-1100W Power Supply

The following table lists the power cords that are supported by the Cisco ASR1000X-AC-1100W Power Supply.

Table 7: Power Cords Supported by the Cisco ASR1000X-AC-1100W Power Supply

| Power Cord Item Number | Description |
|------------------------|--|
| 250V NEMA L6 Cables | |
| CAB-L620P-C13-JPN | Power Cord, 250VAC, 15A, NEMA L6-20 to C13, JAPAN |
| CAB-L620P-C13-US | Power Cord, 250VAC, 15A, NEMA L6-20 to C13, US |
| Cabinet C14 Cables | |
| CAB-C13-C14-2M | Power Cord Jumper, C13-C14 Connectors, 2 Meter Length |
| CAB-C13-C14-AC | Power cord, C13 to C14 (recessed receptacle), 10A |
| CAB-C13-C14-JMPR | Recessed receptacle AC power cord 27in |
| CAB-C13-CBN | Cabinet Jumper Power Cord, 250 VAC 10A, C14-C13 Connectors |
| Power Cables | |
| CAB-AC | AC Power Cord (North America), C13, NEMA 5-15P, 2.1m |
| CAB-ACA | AC Power Cord (Australia), C13, AS 3112, 2.5m |
| CAB-ACC | Power Cord - China |
| CAB-ACE | AC Power Cord (Europe), C13, CEE 7, 1.5M |
| CAB-ACI | AC Power Cord (Italy), C13, CEI 23-16, 2.5m |
| CAB-ACR | AC Power Cord (Argentina), C13, EL 219 (IRAM 2073), 2.5m |
| CAB-ACS | AC Power Cord (Switzerland), C13, IEC 60884-1, 2.5m |

| Power Cord Item Number | Description |
|------------------------|--|
| CAB-ACU | AC Power Cord (UK), C13, BS 1363, 2.5m |
| CAB-C15-ACB | AC Power Cord (Brazil), C15, NBR 14136, 2.5m |
| CAB-IND | AC Power Cord (India) |
| CAB-JPN | AC Power Cord (Japan), C13, JIS C 8303, 2.5m |
| CAB-N5K6A-US | Power Cord, 250V, 6A, NEMA 6-15 to IEC C13 |

System Power Management

The Cisco ASR 1009-X Router and Cisco ASR 1006-X Router supports power-on-demand design with N+1 power redundancy to meet the power demand. By default, the power redundancy feature is turned off, and the power available to the system is the sum of the power outputs of all power supplies in the chassis.

Power supplies are capable of load sharing. The power redundancy is a software feature. Software keeps track of total output power of all power supplies and the maximum FRU power consumption. The redundant power available to the system is the sum of all power outputs less one of the maximum rated power supplies.

In case of N+1 power redundancy, Power Manager (PM) reserves enough power for backup and to prevent the system from being shut down if a power supply fails. PM will log a warning if the redundant power is insufficient to cover a power supply failure. If the customer ignores the warning, the power over budget can lead to system shut down if the power load of this router exceeds the power capacity. The extreme failure scenario is rare because the power loads of all FRUs (cards, and fan modules) are seldom high at the same time.

The FRU power consumption is decided by look-up inventory of the cards. Power Manager will look up the power consumption based on the FRU type.

Power Management Policies

The guidelines for deployment of the power redundancy specify the minimum number of power supplies required for each chassis in a redundancy mode. PM is responsible for monitoring whether the PS deployment can meet the system power demand or not. If the user oversubscribes the power, PM logs an error to inform the users to correct the deployment errors. However, PM does not pre-emptively deny power to any FRU if the power demand is over budget.

N+1 Power Redundancy Policies

In N+1 power redundancy, PM reserves enough backup power and protect the system from any single PS failure. Users must follow the deployment guideline to install adequate number of PS to protect the system. PM monitors FRU and PS OIR, and failover conditions. It logs an error to warn the user if the PS installation does not meet the power demand.

By default, the power redundancy is turned off, and the redundant power is 0.

Use the **platform power redundancy-mode nplus1** command to turn on the N+1 Power Redundancy feature.

```
Router# configure terminal
Router(config)# platform power redundancy-mode nplus1
```

After a user changes the redundancy mode, PM recalculates the power allocation and updates power installation status accordingly. It logs *Insufficient number of power supplies* error if the power demand exceeds the power available.

Use the **no platform power redundancy-mode nplus1** command to disable the power redundancy feature.

After a user disables the power redundancy feature, the power available to the system is the sum of power outputs of all power supplies in the chassis.

The following example shows how to disable the power redundancy feature:

```
Router# configure terminal
Router(config)# no platform power redundancy-mode nplus1
```

Show Platform Power Information

The following example shows three power supplies that are installed in ASR 1009-X Router with no power redundancy configuration.

```
Router# show platform power
Chassis type: ASR1009-X
Slot      Type                State                Allocation (W)
-----
0         ASR1000-SIP40        ok                   64
  0/0     SPA-5X1GE-V2        inserted            18.10
1         ASR1000-SIP40        ok                   64
  1/0     SPA-8X1GE-V2        inserted            20
  1/3     SPA-4XOC3-POS       inserted            14
2         ASR1000-SIP40        ok                   64
R0        ASR1000-RP2          ok, active           105
R1        ASR1000-RP2          unknown              0
F0        ASR1000-ESP80        ok, standby          310
F1        ASR1000-ESP80        ok, active           350
P6        ASR1000X-FAN         ok                   125
P7        ASR1000X-FAN         ok                   125
P8        ASR1000X-FAN         ok                   125
Slot      Type                State                Capacity (W)  Load (W)
-----
P0        ASR1000X-AC-1100W   ok                   1100          228
P1        ASR1000X-AC-1100W   ok                   1100          216
P3        ASR1000X-AC-1100W   ok                   1100          204
Total load: 648 W, total capacity: 3300 W. Load / Capacity is 19%
Power capacity:      3300 W
Redundant allocation: 0 W
PS/Fan allocation:   375 W
FRU allocation:      1009 W
-----
Excessive Power in Reserve: 1916 W
Excessive / (Capacity - Redundant) is 58%

Power Redundancy Mode: none
Power Allocation Status: Sufficient
```

The following example shows three power supplies that are installed in the ASR 1006-X Router with N+1 configuration.

```

Router# show platform power
Chassis type: ASR1006-X
Slot      Type              State              Allocation (W)
-----
1         ASR1000-SIP40         ok                 64
R0        ASR1000-RP2           ok, active         105
R1        ASR1000-RP2           unknown            0
F0        ASR1000-ESP80         ok, active         350
P6        ASR1000X-FAN          ok                 125
P7        ASR1000X-FAN          ok                 125
Slot      Type              State              Capacity (W) Load (W)
-----
P0        ASR1000X-AC-1100W    ok                 1100      132
P1        ASR1000X-AC-1100W    ok                 1100      144
P2        ASR1000X-AC-1100W    ok                 1100      144
Total load: 420 W, total capacity: 3300 W. Load/Capacity is 12%
Power capacity:          3300 W
Redundant allocation:    1100 W
PS/Fan allocation:      250 W
FRU allocation:          519 W
-----
Excessive Power in Reserve: 1431 W
Excessive / (Capacity - Redundant) is 65%
Power Redundancy Mode: nplus1
Power Allocation Status: Sufficient

```

System Power Management Log Messages

The following logs are generated when either power capacity or power allocation is changed:

- If the power capacity (see definition below) is less than the power allocation, PM will post the warning:

```

*Aug 17 10:57:48.154: %CMRP_PFU-4-PWR_MGMT_WARN: R0/0: cmand: WARNING:
Insufficient number of power supplies (2) is installed for power redundancy
mode <nplus1/none>. The system needs 249 watts additional power.

```

- If the power capacity is greater or equal to the power allocation, PM will clear the warning with the message:

```

*Aug 17 11:14:49.691: %CMRP_PFU-6-PWR_MGMT_OK: R0/0: cmand:
Sufficient number of power supplies (4) is installed for
power redundancy mode <nplus1/none> (excessive power 1951 watts).

```



CHAPTER 4

Preparing Your Site for Installation

This chapter contains important safety information you should know before working with the Cisco ASR 1009-X Router and Cisco ASR 1006-X Router, and guides you through the process of preparing your site for router installation. It contains the following topics:

- [Prerequisites and Preparation](#) , on page 27
- [Site Planning Checklist](#), on page 28
- [Safety Guidelines](#), on page 28
- [Compliance Requirements](#), on page 29
- [Cautions and Regulatory Compliance Statements for NEBS](#) , on page 30
- [Standard Warning Statements](#), on page 31
- [General Safety Warnings](#), on page 31
- [Site Planning](#), on page 34
- [Preventing Electrostatic Discharge Damage](#), on page 42
- [Electrical Safety](#), on page 43
- [Chassis-Lifting Guidelines](#), on page 44
- [Tools and Equipment](#), on page 45
- [Unpacking and Verifying Shipping Contents](#), on page 45
- [Checking the Shipping Container Contents](#), on page 46
- [Cisco ASR 1000 Series Router Installation Checklist](#), on page 47

Prerequisites and Preparation

Before you perform any of the procedures in this guide, we recommend that you:

- Read the safety guidelines in the next section and review the electrical safety and ESD-prevention guidelines in this guide.
- Ensure that you have all of the necessary tools and equipment (see [Tools and Equipment](#), on page 45).
- Have access to the *Cisco ASR 1000 Series Aggregation Services Routers Software Configuration Guide* (an online document that is available for viewing or download at Cisco.com) during the installation.
- The power and cabling requirements that must be in place at your installation site
- The equipment required to install the router
- The environmental conditions your installation site must meet to maintain normal operation

Before installing your Cisco ASR 1000 Series Aggregation Services Router, you must consider power and cabling requirements that must be in place at your installation site, special equipment for installing the router,

and the environmental conditions your installation site must meet to maintain normal operation. This chapter guides you through the process of preparing for router installation.

The shipping package for the router is engineered to reduce the chances of product damage associated with routine material handling experienced during shipment:

- Router should always be transported or stored in its shipping package in the upright position.
- Keep the router in the shipping container until you have determined the installation site.



Note Inspect all items for shipping damage. If an item appears damaged, contact a Cisco customer service representative immediately.

Site Planning Checklist

Use the following checklist to perform and account for all the site-planning tasks described in this chapter:

- The site meets the environmental requirements.
- The site air conditioning system can compensate for the heat dissipation of the Cisco ASR 1000 Series Routers.
- The floor space that the Cisco ASR 1000 Series Routers occupy can support the weight of the system).
- Electrical service to the site complies with the requirements.
- The electrical circuit servicing the Cisco ASR 1000 Series Routers complies with the requirements).
- Consideration has been given to the console port wiring, and limitations of the cabling involved, according to TIA/EIA-232F.
- The Cisco ASR 1000 Series Router Ethernet cabling distances are within limitations.
- The equipment rack in which you plan to install the Cisco ASR 1000 Series chassis complies with requirements.
- Careful consideration has be given to safety, ease of maintenance, and proper airflow in selecting the location of the rack.

Safety Guidelines

Before you begin the installation or replacement procedure, review the safety guidelines in this section to avoid injuring yourself or damaging the equipment.



Note This section contains guidelines, and do not include every potentially hazardous situation. When you install a router, always use common sense and caution.

Safety Warnings

Safety warnings appear throughout this publication in procedures that, if performed incorrectly, might harm you. A warning symbol precedes each warning statement.

Before you install, configure, or perform maintenance on the router, review the documentation for the procedure you are about to perform, paying special attention to the safety warnings. If you need translations of the safety warnings.



Note Do not unpack the system until you are ready to install it. Keep the chassis in the shipping container to prevent accidental damage until you determined an installation site. Use the appropriate unpacking documentation included with the system.

Read the installation instructions in this document before you connect the system to its power source. Failure to read and follow these guidelines could lead to an unsuccessful installation and possibly damage to the system and components.

Safety Recommendations

The following guidelines will help to ensure your own safety and protect your Cisco equipment. This list does not cover all potentially hazardous situations, so *be alert*.

- Cisco safety policy is that all of its routers must conform to the requirements of IEC 60950, with appropriate national deviations, as a minimum. In addition, Cisco routers must also meet the requirements of any other normative documents (for example, standards, technical specifications, laws or regulations).
- Review the safety warnings listed in the *Regulatory Compliance and Safety Information for the Cisco ASR 1000 Series Aggregation Services Routers* that accompanied your Cisco ASR 1000 Series Router, before installing, configuring, or maintaining the router.
- Never attempt to lift an object that might be too heavy for you to lift by yourself.
- Always turn all power supplies off and unplug all power cables before opening the chassis.
- Always unplug the power cable before installing or removing a chassis.
- Keep the chassis area clear and dust free during and after installation.
- Keep tools and chassis components away from walk areas.
- Do not wear loose clothing, jewelry (including rings and chains), or other items that could get caught in the chassis. Fasten your tie or scarf and sleeves.
- The Cisco ASR 1000 Series Routers operate safely when it is used in accordance with its marked electrical ratings and product usage instructions.

Compliance Requirements

This section includes Safety Compliance and Network Equipment Building Systems (NEBS) standards. The Cisco ASR 1000 Series Routers are in compliance with national and international standards as described in the following table.

You must observe the following safety guidelines when working with any equipment that connects to electrical power or telephone wiring. These guidelines help you avoid injuring yourself or damaging the devices.

Table 8: Safety Compliance and NEBS Requirements

| Specification | Description |
|---------------------------------------|---|
| EMC/Safety | <p>Caution To comply with Class A emissions requirements, shielded-twisted pair T1/E1 cables must be used with the 8-port channelized T1/E1 SPA interface in any Cisco ASR 1000 chassis.</p> <p>Caution To comply with Class A emissions requirements, shielded-twisted pair T1/E1 cables must be used with the 8-port channelized T1/E1 NIM interface in any Cisco ASR 1000 chassis.</p> |
| Telcordia NEBS GR-1089-Core Statement | <p>Caution To comply with the Telcordia GR-1089 NEBS standard for electromagnetic compatibility and safety, for Ethernet RJ-45 ports, use only shielded Ethernet cables that are grounded on both ends. In a NEBS installation, all Ethernet ports are limited to intrabuilding wiring.</p> |

Cautions and Regulatory Compliance Statements for NEBS

The following table lists cautions, regulatory compliance statements, and requirements for the Network Equipment-Building System (NEBS) certification from the Telcordia Electromagnetic Compatibility and Electrical Safety – Generic Criteria for Network Telecommunications Equipment (A Module of LSSGR, FR-64; TSGR, FR-440; and NEBSFR, FR-2063) Telcordia Technologies Generic Requirements, GR-1089-CORE.

Attach an ESD-preventive wrist strap to your wrist and to a bare metal surface.



Caution To comply with the Telcordia GR-1089 NEBS standard for electromagnetic compatibility and safety, for Ethernet RJ-45 ports, use only shielded Ethernet cables that are grounded on both ends. In a NEBS installation, all Ethernet ports are limited to intrabuilding wiring.



Caution The intrabuilding ports of the equipment or subassembly is only suitable for connection to intrabuilding or unexposed wiring or cabling. The intrabuilding ports of the equipment or subassembly **MUST NOT** be metallically connected to interfaces that connect to the OSP or its wiring. These interfaces are designed for use only as intrabuilding interfaces (Type 2 or Type 4 ports as described in GR-1089-CORE), and require isolation from the exposed OSP cabling. The addition of primary protectors is not sufficient protection in order to connect these interfaces metallically to OSP wiring.

Products that have an AC power connection are intended for deployments where an external surge protective device (SPD) is used at the AC power service equipment as defined by the National Electric Code (NEC).

This product is designed for a common bonding network (CBN) installation.

This product can be installed in a network telecommunication facility or location where the NEC applies.

An electrical conducting path shall exist between the product chassis and the metal surface of the enclosure or rack in which it is mounted or to a grounding conductor. Electrical continuity shall be provided by using thread-forming type mounting screws that remove any paint or nonconductive coatings and establish a metal-to-metal contact. Any paint or other nonconductive coatings shall be removed on the surfaces between the mounting hardware and the enclosure or rack. The surfaces shall be cleaned and an antioxidant applied before installation.

The grounding architecture of this product is DC-isolated (DC-I).

DC-powered products have a nominal operating DC voltage of 48 VDC. Minimal steady state DC operating voltage is 40.5 VDC. Reference American National Standards Institute (ANSI) T1.315, Table 1.

Standard Warning Statements



Note The English warnings in this document are preceded by a statement number. To see the translations of a warning in other languages, look up its statement number in the *Regulatory Compliance and Safety Information for the Cisco ASR 1000 Series Aggregation Services Routers*.

This section describes the warning definition and then lists core safety warnings grouped by topic.



Warning IMPORTANT SAFETY INSTRUCTIONS

Before you work on any equipment, be aware of the hazards involved with electrical circuitry and be familiar with standard practices for preventing accidents. Read the installation instructions before using, installing, or connecting the system to the power source. Use the statement number provided at the end of each warning statement to locate its translation in the translated safety warnings for this device.

SAVE THESE INSTRUCTIONS



General Safety Warnings



Warning Read the installation instructions before using, installing, or connecting the system to the power source.



Warning To reduce risk of electric shock or fire, installation of the equipment must comply with local and national electrical codes.



Warning To comply with the Class A emissions requirements shielded twisted pair T1/E1 cables must be used for SPA-8-Port Channelized T1/E1 SPA (SPA-8XCHT1/E1) on the Cisco ASR 1006, ASR 1004, and ASR 1002. EN55022/CISPR22 Statement



Warning To comply with Class A emissions requirements- shielded management Ethernet, CON, and AUX cables on the Cisco ASR 1002 Router must be used.



Warning Only trained and qualified personnel should be allowed to install, replace, or service this equipment.



Warning This product requires short-circuit (overcurrent) protection to be provided as part of the building installation. Install only in accordance with national and local wiring regulations.



Warning This unit might have more than one power supply connection. To reduce risk of electric shock, remove all connections to de-energize the unit.

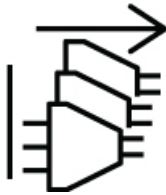

Warning This unit is intended for installation in restricted access areas. Only skilled, instructed, or qualified personnel can access a restricted access area.



Warning The plug-socket combination must be accessible at all times, because it serves as the main disconnecting device.



Warning Hazardous voltage or energy may be present on power terminals. To reduce the risk of electric shock, always replace the cover when terminals are not in service. Be sure uninsulated conductors are not accessible when the cover is in place.



Warning To reduce risk of fire, use copper conductors only.



Warning This equipment must be grounded. To reduce the risk of electric shock, never defeat the ground conductor or operate the equipment in the absence of a suitably installed ground conductor. Contact the appropriate electrical inspection authority or an electrician if you are uncertain that suitable grounding is available.



Warning Hazardous voltage or energy is present on the backplane when the system is operating. Use caution when servicing.



Warning This product is a Class 1 laser product.



Warning This is a Class 1 LED product.



Warning Laser radiation is present when the system is open.



Warning Do not stare into the laser beam.



Warning Invisible laser radiation is present. Do not expose to users of telescopic optics. This applies to Class 1/1M laser products.



Warning Invisible laser radiation may be emitted from the end of the unterminated fiber cable or connector. Do not view directly with optical instruments. Viewing the laser output with certain optical instruments, for example, eye loupes, magnifiers, and microscopes, within a distance of 100 mm, may pose an eye hazard.

**Warning**

To reduce risk of fire, explosion, or leakage of flammable liquid or gas:

- Replace the battery only with the same or equivalent type recommended by the manufacturer.
- Do not dismantle, crush, puncture, use a sharp tool to remove, short the external contacts, or dispose of the battery in fire.
- Do not use if battery is warped or swollen.
- Do not store or use battery in a temperature $>$.
- Do not store or use battery in low air pressure environment $<$.

**Warning**

Do not touch or bridge the metal contacts on the battery. Unintentional discharge of the batteries can cause serious burns.

**Warning**

To prevent personal injury or damage to the chassis, never attempt to lift or tilt the chassis using the handles on modules, such as power supplies, fans, or cards. These types of handles are not designed to support the weight of the unit.

**Warning**

Blank faceplates and cover panels serve three important functions: they reduce the risk of electric shock and fire, they contain electromagnetic interference (EMI) that might disrupt other equipment, and they direct the flow of cooling air through the chassis. Do not operate the system unless all cards, faceplates, front covers, and rear covers are in place.

Site Planning

This section contains site planning information, and will help you plan for the installation of the Cisco ASR 1000 Series Routers.

General Precautions

Observe the following general precautions when using and working with your Cisco ASR 1000 Series Routers.

- Keep your system components away from radiators and heat sources and do not block cooling vents.
- Do not spill food or liquids on your system components and never operate the product in a wet environment.
- Do not push any objects into the openings of your system components. Doing so can cause fire or electric shock by shorting out interior components.

- Position system cables and power supply cables carefully. Route system cables and the power supply cable and plug so that they cannot be stepped on or tripped over. Be sure that nothing else rests on your system component cables or power cable.
- Do not modify power cables or plugs. Consult a licensed electrician or your power company for site modifications. Always follow your local and national wiring rules.
- If you turn off your system, wait at least 30 seconds before turning it on again to avoid system component damage.
- For optimal installation performance when adding line cards to an empty chassis, it is recommended to load the bottommost slot first and then progressively move upwards to load the remaining slots.

Site Selection Guidelines

The Cisco ASR 1000 Series Routers require specific environmental operating conditions. Temperature, humidity, altitude, and vibration can affect the performance and reliability of the router. The following sections provide specific information to help you plan for the proper operating environment.

The Cisco ASR 1000 Series Routers are designed to meet the industry EMC, safety, and environmental standards described in the *Regulatory Compliance and Safety Information for the Cisco ASR 1000 Series Aggregation Services Routers* document.

Site Environmental Requirements

Environmental monitoring protects the system and components from damage caused by excessive voltage and temperature conditions. To ensure normal operation and avoid unnecessary maintenance, plan and prepare your site configuration *before* installation. After installation, make sure the site maintains the environmental characteristics, as shown in the following table.

Table 9: Cisco ASR 1009-X Router and Cisco ASR 1006-X Router Environmental Tolerance

| Environmental Characteristic | Minimum | Maximum |
|---|------------|------------------------------------|
| Operating temperature (nominal) | 0° C | 40° C (40° C up to 10,000 feet) |
| Operating temperature (short term) | 0° C | 50° C |
| Storage temperature | -20° C | +70° C |
| Operative humidity (nominal) (relative humidity) | 10% | 90% |
| Operative humidity (short term) | 5% | 90% |
| Storage humidity (relative humidity) | 5% | 95% |
| Altitude, operating: over allowable temperature range (0 to 50 degrees C) | -500 feet | 6,000 feet |
| Altitude, nonoperating: over allowable temperature range | -1000 feet | 50,000 feet |
| Thermal shock nonoperating with change over time of 3 minutes | -25° C | +70° C |

| Environmental Characteristic | Minimum | Maximum |
|--|---------|---------|
| Thermal Shock - Operating at 2.5 degree C per minute | 0° C | +50° C |

Physical Characteristics

Be familiar with the physical characteristics of the Cisco ASR 1009-X Router and Cisco ASR 1006-X Router to assist you in placing the system at a proper location.

For information regarding rack widths supported for the Cisco ASR 1009-X Router and Cisco ASR 1006-X Router, see the following sections:

- 19 in.—See the *General Rack-Selection Guidelines* section.
- 23 in.—See the *Guidelines for 23-in. (Telco) Racks* section.

The following table shows the weight and dimensions of the Cisco ASR 1009-X Router and Cisco ASR 1006-X Routers.

Table 10: Physical Characteristics of Cisco ASR 1009-X Router and Cisco ASR 1006-X Router

| Characteristic | Cisco ASR 1009-X | Cisco ASR 1006-X |
|----------------|---|---|
| Height | 15.72 in. (399.3 mm) —9RU | 10.47 in. (265.9 mm) —6RU |
| Width | 17.2 in. (437.4 mm) | 17.2 in. (437.4 mm) |
| Depth | 18.15 in. (461.0 mm) | 18.15 in. (461.0 mm) |
| Weight | <ul style="list-style-type: none"> • 50 lb (11.35 kg) empty • 154 lb (70 kg) (with three fan modules, four AC power supplies, two power bay blanks, two Cisco ASR 1000 Series 200-Gbps ESPs (ASR1000-ESP200), two Cisco ASR 1000 Series RP2s (ASR1000-RP2), three Cisco ASR 1000 Series 100-Gbps MIPs (ASR1000-MIP100), six EPA blanks and no EPAs) | <ul style="list-style-type: none"> • 36.5 lb empty • 112 lb (50.91 kg) (with two fan modules, three AC power supplies, three power bay blanks, two Cisco ASR 1000 Series 100-Gbps ESPs (ASR1000-ESP100), two Cisco ASR 1000 Series RP2s (ASR1000-RP2), two Cisco ASR 1000 Series 100-Gbps MIPs (ASR1000-MIP100), four EPA blanks and no EPAs) |

The following list describes additional Cisco ASR 1009-X Router and Cisco ASR 1006-X Router characteristics:

- Chassis height meets EIA-310 rack spacing 1RU (1.71 in. or 43.43 mm), universal rack mount
- Chassis width meets EIA-310 19 in. (17.3 in. or 439.42 mm) wide with rack brackets
- Cable-management brackets allow a bend radius of 1.5 in. (38.1 mm) for cables
- Ships with forward rack-mount brackets installed and an extra set included in the accessory kit

Site Power Guidelines

The Cisco ASR 1000 Series Routers have specific power and electrical wiring requirements. Adhering to these requirements ensures reliable operation of the system. Follow these precautions and recommendations when planning your site for the Cisco ASR 1000 Series Router:

- The redundant power option provides a second, identical power supply to ensure that power to the chassis continues uninterrupted if one power supply fails or input power on one line fails.
- In systems configured with the redundant power option, connect each of the two power supplies to a separate input power source. If you fail to do this, your system might be susceptible to total power failure due to a fault in the external wiring or a tripped circuit breaker.
- To prevent a loss of input power, be sure the total maximum load on each circuit supplying the power supplies is within the current ratings of the wiring and breakers.
- Check the power at your site before installation and periodically after installation to ensure that you are receiving clean power. Install a power conditioner if necessary.
- Provide proper grounding to avoid personal injury and damage to the equipment due to lightning striking power lines or due to power surges. The chassis ground must be attached to a central office or other interior ground system.



Caution

This product requires short-circuit (overcurrent) protection, to be provided as part of the building installation. Install only in accordance with national and local wiring regulations.



Note

The Cisco ASR 1000 Series Router installation must comply with all applicable codes and is approved for use with copper conductors only. The ground bond fastening hardware should be of compatible material and preclude loosening, deterioration, and electrochemical corrosion of hardware and joined material. Attachment of the chassis ground to a central office or other interior ground system must be made with an AWG #6 gauge wire, copper ground conductor at a minimum.

Electrical Circuit Requirements

Each Cisco ASR 1009-X Router and Cisco ASR 1006-X Router requires a dedicated electrical circuit. If you equip it with dual-power feeds, you must provide a separate circuit for each power supply to avoid compromising the power redundancy feature.

The Cisco ASR 1009-X Router and Cisco ASR 1006-X Router can be powered by a DC or AC source. Ensure that equipment grounding is present and observe power-strip ratings. Make sure that the total ampere rating of all the products plugged into the power strip does not exceed 80 percent of the rating.



Note

The Cisco ASR 1009-X Router and Cisco ASR 1006-X Router can support up to six AC 1100 W power supplies or six DC 950 W power supplies. The AC and DC power supplies cannot be mixed in a chassis.

The following table contains specifications for DC-powered systems for the Cisco ASR 1009-X Router and Cisco ASR 1006-X Router.

Table 11: Cisco ASR 1009-X Router and Cisco ASR 1006-X Router DC Power Supply System Input Requirements

| System Input Rating (Amps) | Circuit Breaker Amps | | AWG # Wire |
|----------------------------|----------------------|---------|---------------|
| | Minimum | Maximum | |
| 26 | 35 | 50 | 10 |



Note The Cisco ASR 1009-X Router and Cisco ASR 1006-X Router AC power supply requires a 35 A circuit breaker.

The following table lists AC and DC power supply system rating requirements for the Cisco ASR 1009-X Router and Cisco ASR 1006-X Router.

Table 12: AC and DC Power Supply System Rating Specifications for the Cisco ASR 1009-X Router and Cisco ASR 1006-X Router

| Description | Specification |
|-------------------------------|------------------------------------|
| Power supply declared ratings | AC = 85–264 VAC DC = –40–72 VDC |
| Line frequency rating | 50/60 Hz for AC power supplies |

Site Cabling Guidelines

This section contains guidelines for wiring and cabling at your site. When preparing your site for network connections to the Cisco ASR 1000 Series Router, consider the type of cable required for each component, and the cable limitations. Consider the distance limitations for signaling, EMI, and connector compatibility. Possible cable types are fiber, thick or thin coaxial, foil twisted-pair, or unshielded twisted-pair cabling.

Also consider any additional interface equipment you need, such as transceivers, hubs, switches, channel service units (CSUs), or data service units (DSUs).

The E1 interface on the Cisco 8-Port Channelized T1/E1 SPA interface uses RJ-48c receptacles for E1 (120-Ohm) cables with RJ-45 connectors. You can use all ports simultaneously. Each E1 connection supports interfaces that meet the G.703 standards. The RJ-45 connection does not require an external transceiver. The E1 ports are E1 interfaces that use 120-ohm shielded twisted-pair (STP) cables. Shielded cables must be used to connect to the DB-25 alarm connector on both the AC and DC power supplies in order to comply with FCC/EN55022/CISPR22 Class A emissions requirements.



Warning Shielded-twisted pair T1/E1 cables must be used with the 8-port channelized T1/E1 SPA interfaces in any Cisco ASR 1000 Series chassis. This is required for Compliance with Class A emissions requirements for EMC.



Warning Shielded-twisted pair T1/E1 cables must be used with any of the T1/E1 NIM interfaces in any Cisco ASR 1000 Series chassis. This is required for Compliance with Class A emissions requirements for EMC.

Before you install the Cisco ASR 1000 Series Router, have all additional external equipment and cables on hand. For ordering information, contact a customer service representative.

The extent of your network and the distances between network interface connections depend in part on the following factors:

- Signal type
- Signal speed
- Transmission medium

The distance and rate limits referenced in the following sections are the IEEE-recommended maximum speeds and distances for signaling purposes. Use this information as a guideline in planning your network connections *>prior to* installing the Cisco ASR 1000 Series Router.

If wires exceed recommended distances, or if wires pass between buildings, give special consideration to the effect of a lightning strike in your vicinity. The electromagnetic pulse caused by lightning or other high-energy phenomena can easily couple enough energy into unshielded conductors to destroy electronic devices. If you have had problems of this sort in the past, you may want to consult experts in electrical surge suppression and shielding.

Console Port Connections

The Cisco ASR 1000 Series Routers provide console and auxiliary ports to connect a terminal or computer for local console access.

Both ports have RJ-45 connectors, support RS-232 asynchronous data, and have distance recommendations specified in the IEEE RS-232 standard.

Interference Considerations

When wires are run for any significant distance, there is a risk that stray signals will be induced on the wires as interference. If interference signals are strong, they can cause data errors or damage to the equipment.

The following sections describe sources of interference and how to minimize its effects on the Cisco ASR 1000 Series Router system.

Electromagnetic Interference

All equipment powered by AC current can propagate electrical energy that can cause electromagnetic interference (EMI) and possibly affect the operation of other equipment. The typical sources of EMI are equipment power cords and power service cables from electric utility companies.

Strong EMI can destroy the signal drivers and receivers in the Cisco ASR 1000 Series Router and even create an electrical hazard by causing power surges through power lines into installed equipment. These problems are rare, but could be catastrophic.

To resolve these problems, you need specialized knowledge and equipment, which could consume substantial time and money. However, you should ensure that you have a properly grounded and shielded electrical environment, paying special attention to the need for electrical surge suppression.

The following table lists electrode magnetic compliance standards for the Cisco ASR 1000 Series Routers.

Table 13: EMC Standards

| | |
|----------------------|---|
| EMC Standards | FCC 47 CFR Part 15 Class A |
| | VCCI Class A |
| | AS/NSZ Class A |
| | ICES-003 Class A |
| | EN55022/CISPR 22 Information Technology Equipment (Emissions) |
| | EN55024/CISPR 24 Information Technology Equipment (Immunity) |
| | EN300 386 Telecommunications Network Equipment (EMC) |
| | EN50082-1/EN61000-6-1 Generic Immunity Standard |
| CE marking | UL60950-1 |
| | CSA C22.2 No. 60950-1-03 |
| | EN 60950-1 |
| | IEC 60950-1 |
| | AS/NZS 60950.1 |

Radio Frequency Interference

When electromagnetic fields act over a long distance, radio frequency interference (RFI) can be propagated. Building wiring can often act as an antenna, receiving the RFI signals and creating more EMI on the wiring.

If you use twisted-pair cable in your plant wiring with a good distribution of grounding conductors, the plant wiring is unlikely to emit radio interference. If you exceed the recommended distances, use a high-quality twisted-pair cable with one ground conductor for each data signal.

Lightning and AC Power Fault Interference

If signal wires exceed recommended cabling distances, or if signal wires pass between buildings, you should consider the effect that a lightning strike in your vicinity might have on the Cisco ASR 1000 Series Router.

The electromagnetic pulse (EMP) generated by lightning or other high-energy phenomena can couple enough energy into unshielded conductors to damage or destroy electronic equipment. If you have previously experienced such problems, you should consult with RFI/EMI experts to ensure that you have adequate electrical surge suppression and shielding of signal cables in your Cisco ASR 1000 Series Router operating environment.

Rack-Mounting Guidelines

This section describes guidelines on rack-mounting.

Precautions for Rack-Mounting

The following rack-mount guidelines are provided to ensure your safety:

- Do not move large racks by yourself. Due to the height and weight of a rack, a minimum of two people are required to accomplish this task.
- Ensure that the rack is level and stable before extending a component from the rack.
- Ensure that proper airflow is provided to components in the rack.
- Do not step or stand on any component or system when servicing other systems or components in a rack.
- When mounting the Cisco ASR 1000 Series Router in a partially filled rack, load the rack from the bottom to the top with the heaviest component at the bottom of the rack.
- If the rack is provided with stabilizing devices, then install the stabilizers before mounting or servicing the unit in the rack.

General Rack Selection Guidelines

Cisco ASR 1000 Series Routers can be mounted in most two-post or four-post, 19-in. equipment racks that comply with the Electronics Industries Association (EIA) standard for equipment racks (EIA-310-D 19-in.). The rack must have at least two posts with mounting flanges to mount the chassis.



Caution When mounting a chassis in any type of rack equipment, ensure that the inlet air to the chassis does not exceed 131°F (55°C).

The distance between the center lines of the mounting holes on the two mounting posts must be 18.31 in. ± 0.06 in. (46.50 cm ± 0.15 cm). The rack-mounting hardware included with the chassis is suitable for most 19-in. equipment racks.

Consider installing the Cisco ASR 1000 Series Router in a rack with the following features:

- NEBS compliant, 19-in. (48.3 cm) wide rack.
- EIA or ETSI hole patterns in the mounting rails. Required mounting hardware is shipped with the Cisco ASR 1000 Series Router. If the rack that you plan to install the system in has metric-threaded rails, you must provide your own metric mounting hardware.
- Perforated top and open bottom for ventilation to prevent overheating.
- Leveling feet for stability.



Note The Cisco ASR 1000 Series Router should *not* be installed in an enclosed rack because the chassis requires an unobstructed flow of cooling air to maintain acceptable operating temperatures for its internal components. Installing the router in any type of enclosed rack—even with the front and back doors removed—could disrupt the air flow, trap heat next to the chassis, and cause an overtemperature condition inside the router. If you use an enclosed rack, make certain that there are air vents on all sides of the rack and there is proper ventilation.

Guidelines for 23 in. (Telco) Racks

If needed, you can also install the Cisco ASR 1000 Series Routers in 23 in. (Telco) racks. For information on adapters needed for 23 in. racks, please contact the Newton Instrument Company:

- <http://www.ewton.com>
- 111 East A Street, Butner NC, USA, 27509

- 919 575-6426

Equipment Rack Guidelines

The placement of the rack can affect personnel safety, system maintenance, and the system ability to operate within the environmental characteristics described in the *Site Environmental Requirements* topic. Choose a proper location for the Cisco ASR 1000 Series Router by following the guidelines below.

Locating for Safety

If the Cisco ASR 1000 Series Router is the heaviest or the only piece of equipment in the rack, consider installing it at or near the bottom to ensure that the rack center of gravity is as low as possible.

For additional information about the proper placement of electronic equipment, see the document *GR-63-CORE, Network Equipment Building System (NEBS) Requirements: Physical Protection*.

Locating for Easy Maintenance

Keep at least 3 feet of clear space in front and behind the rack. This space ensures that you can remove the Cisco ASR 1000 Series Router components and perform routine maintenance and upgrades easily.

Avoid installing the Cisco ASR 1000 Series Router in a congested rack and consider how the routing of cables from other pieces of equipment in the same rack could affect access to the routers cards.

The front and top of the chassis must remain unobstructed to ensure adequate airflow and prevent overheating inside the chassis.

Allow the following clearances for normal system maintenance:

- At the top of the chassis—At least 3 in. (7.6 cm)
- In the front of the chassis—3 to 4 ft (91.44 cm to 121.92 cm)



Note When installing the Cisco ASR 1013 chassis in a 42RU equipment rack, allow at least one to two inches (2.54 cm to 5.08 cm) of vertical clearance between the router and any equipment above or below it.

To avoid problems during installation and ongoing operation, follow these general precautions when you plan the equipment locations and connections:

- Use the **show environment all** command regularly to check the internal system status. The environmental monitor continually checks the interior chassis environment; it provides warnings for high temperature and creates reports on any occurrences. If warning messages are displayed, take immediate action to identify the cause and correct the problem.
- Keep the Cisco ASR 1000 Series Router off the floor and out of areas that collect dust.
- Follow ESD prevention procedures to avoid damage to equipment. Damage from static discharge can cause immediate or intermittent equipment failure.

Preventing Electrostatic Discharge Damage

Electrostatic discharge (ESD) damage, occurs when electronic cards or components are improperly handled and can result in complete or intermittent failures. The performance routing engine (PRE), and all line cards consist of a printed circuit card that is fixed in a metal carrier. Electromagnetic interference (EMI) shielding and connectors are integral components of the carrier. Although the metal carrier helps to protect the cards

from ESD, use an antistatic strap each time you handle the modules. Handle the carriers by the edges only; never touch the cards or connector pins.



Caution Always tighten the captive installation screws on all system components when you are installing them. These screws prevent accidental removal of the module, provide proper grounding for the system, and help to ensure that the bus connectors are properly seated in the backplane.

Static electricity can harm delicate components inside your system. To prevent static damage, discharge static electricity from your body before you touch any of your system components, such as a microprocessor. As you continue to work on your system, periodically touch an unpainted metal surface on the computer chassis.

Following are guidelines for preventing ESD damage:

- Always use an ESD-preventive wrist or ankle strap and ensure that it makes good skin contact. Before removing a card from the chassis, connect the equipment end of the strap to the ESD plug at the bottom of the chassis below the power entry modules.
- Handle line cards by the faceplates and carrier edges only; avoid touching the card components or any connector pins.
- When removing a card, place the removed module component-side-up on an antistatic surface or in a static-shielding bag. If the module will be returned to the factory, immediately place it in a static-shielding bag.
- Avoid contact between the modules and clothing. The wrist strap protects the card from ESD voltages on the body only; ESD voltages on clothing can still cause damage.
- When transporting a sensitive component, first place it in an antistatic container or packaging.
- Handle all sensitive components in a static-safe area. If possible, use antistatic floor pads and workbench pads.



Caution For safety, periodically check the resistance value of the antistatic strap. The measurement should be between 1 and 10 ohms.



Caution Always tighten the captive installation screws on all the system components when you are installing them. These screws prevent accidental removal of the module, provide proper grounding for the system, and help ensure that the bus connectors are properly seated in the backplane.



Note The ESD strap socket can be in a different location on each Cisco ASR 1000 Series Router.

Electrical Safety

All system components are hot-swappable. They are designed to be removed and replaced while the system is operating without presenting an electrical hazard or damage to the system.

Follow these basic guidelines when you are working with any electrical equipment:

- Before beginning any procedures requiring access to the chassis interior, locate the emergency power-off switch for the room in which you are working.
- Disconnect all power and external cables before installing or removing a chassis.
- Do not work alone when potentially hazardous conditions exist.
- Never assume that power has been disconnected from a circuit; always check.
- Do not perform any action that creates a potential hazard to people or makes the equipment unsafe. Never install equipment that appears damaged.
- Carefully examine your work area for possible hazards such as moist floors, ungrounded power extension cables, and missing safety grounds.

In addition, use the guidelines that follow when working with any equipment that is disconnected from a power source but is still connected to telephone wiring or other network cabling.

- Never install telephone wiring during a lightning storm.
- Never install telephone jacks in wet locations unless the jack is specifically designed for wet locations.
- Never touch uninsulated telephone wires or terminals unless the telephone line has been disconnected at the network interface.
- Use caution when installing or modifying telephone lines.



Warning Do not work on the system or connect or disconnect cables during periods of lightning activity. Statement 1006

Chassis-Lifting Guidelines

The chassis is not intended to be moved frequently. Before you install the system, ensure that your site is properly prepared so you can avoid having to move the chassis later to accommodate power sources and network connections.

Two or more people are required to lift the chassis. Each time you lift the chassis or any heavy object, follow these guidelines:

- Never attempt to lift the chassis by yourself. Because of the size and weight of the chassis, use at least two people to safely lift and move it without causing injury to yourself or damaging the equipment.
- Ensure that your footing is solid, and balance the weight of the chassis between your feet.
- Lift the chassis slowly; never move suddenly or twist your body as you lift.
- Keep your back straight and lift with your legs, not your back. If you must bend down to lift the chassis, bend at the knees, not at the waist, to reduce the strain on your back muscles.
- Do not remove installed components from the chassis.
- Always disconnect all external cables before lifting or moving the chassis. General Safety Guidelines.



Warning To prevent injury and equipment damage, never attempt to lift or tilt the router chassis using the handles on the fan tray or on line cards. These handles do not support the weight of the chassis.

Procedure

- Step 1** Each person should stand on either side of the chassis and place one hand under the air intake at the bottom front of the chassis.
- Step 2** With the other hand, grasp the top rear of the chassis under the air exhaust and carefully lift the chassis.
-

Tools and Equipment

The tools and equipment listed below are recommended as the minimum necessary to install the Cisco ASR 1000 Series Router. You may need additional tools and equipment to install associated equipment and cables. You may also require test equipment to check electronic and optical signal levels, power levels, and communications links.

- Phillips hand screwdriver
- 3.5mm flat-blade screwdriver
- Tape measure (optional)
- Level (optional)
- Power drill
- 8-gauge wire
- Rack-mount brackets
- Cable-management brackets

Unpacking and Verifying Shipping Contents

When you receive your chassis, perform the following steps and use the shipping contents checklist from the next section:

Procedure

- Step 1** Inspect the box for any shipping damage. (if there is damage contact your service representative).
- Step 2** Unpack the Cisco ASR 1000 Series Router.
- Step 3** Perform a visual inspection of the chassis.
- Step 4** After you have unpacked the system verify that you have received all of the required components. Using the packing list as a guide, take the following steps to check the contents of the Cisco ASR 1000 Series Router shipping container:
- Step 5** Check the contents of the boxes containing accessory items. Verify that you have received all equipment listed in your order.
- Step 6** Check that all Cisco ASR 1000 Series route processors, Cisco ASR 1000 Series embedded services processors, Cisco ASR 1000 Series SPA interface processors (SIPs), and power supplies you ordered are installed in the chassis. Ensure that the configuration matches the packing list.
-

Checking the Shipping Container Contents

Use the components list shown in the following table to check the contents of the Cisco ASR 1000 Series Router shipping container. Do not discard the shipping container. You need the container if you move or ship the Cisco ASR 1000 Series Router in the future.

Table 14: Cisco ASR 1000 Series Router Shipping Container Contents

| Component | Description |
|--|--|
| Chassis | Cisco ASR 1000 Series Router configured with dual AC or dual DC power supplies and a shared port adapter blank panel if a shared port adapter has not been ordered. |
| Accessories Kit Note You must order the Accessories Kit separately if you order the Cisco ASR 1009-X Router or Cisco ASR 1006-X Router chassis as a spare. | <p>Front and rear chassis rack-mount brackets that you will attach to the chassis with the respective screws</p> <p>Three sets of screws, one set for:</p> <ul style="list-style-type: none"> • Front rack-mount brackets (use the black screws) • Rear rack-mount brackets (use the package with the 5 screws) • Cable-management brackets (use the package with the 4 screws) <p>Two cable-management brackets with U-feature design devices attached, with a different size for each chassis.</p> <p>1 RJ-45 to RJ-45 crossover cable 1 RJ-45 to DB-9 (female) adapter</p> |
| ESD, Wrist Strap (disposable) | One disposable wrist strap |
| Documentation | <i>Regulatory Compliance and Safety Information for the Cisco ASR 1000 Series Aggregation Services Routers</i> at http://www.cisco.com/c/en/us/td/docs/routers/asr1000/rcsi/asr1rcsi.html . |
| Optional Equipment | Power cord if an AC power supply was shipped. There are none for the DC power supply units. |



Note Most Cisco documentation is online or on the Cisco Documentation DVD. Documentation that ships with your Cisco ASR 1000 Series Router includes the *Regulatory Compliance and Safety Information for the Cisco ASR 1000 Series Aggregation Services Routers* document, and the *Documentation Roadmap for Cisco ASR 1000 Series*, which provides links and information for the Cisco ASR 1000 Series Aggregation Services Routers documentation.

Cisco ASR 1000 Series Router Installation Checklist

To assist you with your installation and to provide a historical record of what was done by whom, photocopy the Cisco ASR 1000 Series Router Installation Checklist shown in the following table. Use this to record when each procedure or verification is completed. When the checklist is completed, place it in your site log along with the other records for your new router.

Table 15: Cisco ASR 1000 Series Router Installation Checklist

| Task | Verified By | Date |
|--|-------------|------|
| Date chassis received | | |
| Chassis and all accessories unpacked | | |
| Types and numbers of interfaces verified | | |
| Safety recommendations and guidelines reviewed | | |
| Installation Checklist copied | | |
| Site log established and background information entered | | |
| Site power voltages verified | | |
| Site environmental specifications verified | | |
| Required passwords, IP addresses, device names, and so on, available | | |
| Required tools available | | |
| Network connection equipment available | | |
| Cable-management brackets installed (optional, but recommended) | | |
| AC power cable(s) connected to AC source(s) and router | | |
| DC power cable(s) connected to DC source(s) and router | | |
| Network interface cables and devices connected | | |
| System power turned on | | |
| System boot complete (STATUS LED is on) | | |
| Shared port adapters are operational | | |
| Correct hardware configuration displayed after system banner appears | | |



CHAPTER 5

Cisco ASR 1009-X Router and Cisco ASR 1006-X Router Installation

This chapter contains the following topics:

- [Installation Methods, on page 49](#)
- [General Rack Installation Guidelines, on page 50](#)
- [Guidelines for Equipment Rack Installation, on page 50](#)
- [Attaching the Rear Rack-Mount Brackets, on page 51](#)
- [Rack-Mounting the Cisco ASR 1009-X Router and Cisco ASR 1006-X Router, on page 53](#)
- [Attaching the Cable-Management Bracket, on page 60](#)
- [Attaching the Chassis Ground Connection for Cisco ASR 1006-X Router and Cisco ASR 1009-X Router, on page 61](#)
- [Connecting the Shared Port Adapter Cables, on page 64](#)
- [Connecting the Console and Auxiliary Port Cables, on page 64](#)
- [Connecting the Ethernet Management Port, on page 65](#)
- [Connecting Power to the Cisco ASR 1009-X Router and Cisco ASR 1006-X Router , on page 66](#)
- [Connecting a Terminal to the Cisco ASR 1000 Series RP Console Port, on page 70](#)
- [Connecting the System Cables, on page 71](#)

Installation Methods

One set of forward rack-mount brackets come pre-installed on the Cisco ASR 1009-X Router and Cisco ASR 1006-X Router. The accessory kit contains the rear rack-mount brackets, which are optional, and another set of forward rack-mount brackets.

You can mount the chassis in a 19-inch wide (standard), 4-post equipment rack or two-post, using the rack-mount brackets in the accessory kit. The Cisco ASR 1009-X Router and Cisco ASR 1006-X Router supports 6 SIPs and provides superslots (more height and power) for the Cisco ASR1000-RP2s and Cisco ASR1000-ESP cards.



Note The Cisco ASR 1009-X Router and Cisco ASR 1006-X Router usually ships fully loaded. However, you can remove components from the chassis to make the chassis lighter for your rack installation.

General Rack Installation Guidelines

When planning your rack installation, consider the following guidelines:

- The Cisco ASR 1009-X Router overall height is 15.72 in. (399.3 mm) and Cisco ASR 1006-X Router overall height is 10.47 in. (265.9 mm). You can install three Cisco ASR 1009-X Routers and four Cisco ASR 1006-X Routers in a 42RU equipment rack; but must allow at least one to two inches (2.54 cm to 5.08 cm) of vertical clearance between the router and any equipment above or below it. Measure the proposed rack location before mounting the chassis in the rack.
- Before using a particular rack, check for obstructions (such as a power strip) that could impair rack-mount installation. If a power strip does impair a rack-mount installation, remove the power strip before installing the chassis, and then replace it after the chassis is installed.
- Allow sufficient clearance around the rack for maintenance. If the rack is mobile, you can push it back near a wall or cabinet for normal operation and pull it out for maintenance (installing or moving cards, connecting cables, or replacing or upgrading components). Otherwise, allow 19 inches (48.3 cm) of clearance to remove field-replaceable units.
- Maintain a minimum clearance of 3 inches (7.62 cm) on the front, top, and sides of the chassis for the cooling air inlet and exhaust ports, respectively. Avoid placing the chassis in an overly congested rack or directly next to another equipment rack; otherwise, the heated exhaust air from other equipment can enter the inlet air vents and cause an overtemperature condition inside the router.



Caution

To prevent chassis overheating, never install a Cisco ASR 1009-X Router and Cisco ASR 1006-X Router in an enclosed room that is not properly ventilated or air conditioned.

- Always install heavier equipment in the lower half of a rack to maintain a low center of gravity to prevent the rack from falling over.
- Install and use the cable-management brackets included with the Cisco ASR 1009-X Router and Cisco ASR 1006-X Router to keep cables organized and out of the way of the cards and processors. Ensure that cables from other equipment already installed in the rack do not impair access to the cards or require you to disconnect cables unnecessarily to perform equipment maintenance or upgrades.
- Install rack stabilizers (if available) before you mount the chassis.
- Provide an adequate chassis ground (earth) connection for your chassis.

In addition to the preceding guidelines, review the precautions for avoiding excessive temperature conditions in the "Electrical Safety" section.

Guidelines for Equipment Rack Installation

The chassis should already be in the area where you will install it. When installing the Cisco ASR 1009-X Router and Cisco ASR 1006-X Router, consider the following items:

- The Cisco ASR 1009-X Router and Cisco ASR 1006-X Router requires at least 3 inches (7.62 cm) of clearance at the inlet and exhaust vents (the front and top/rear sides of the chassis).

- The Cisco ASR 1009-X Router and Cisco ASR 1006-X Router should be installed off the floor. Dust that accumulates on the floor is drawn into the interior of the router by the cooling fans. Excessive dust inside the router can cause overtemperature conditions and component failures.
- Maintain a minimum clearance of 3 inches (7.62 cm) for the front and rear of the chassis for proper chassis cooling. Avoid placing the chassis in an overly congested rack or directly next to another equipment rack; otherwise, the heated exhaust air from other equipment can enter the inlet air vents and cause an overtemperature condition inside the router.
- If rack space allows, it is recommended to leave one rack unit (1.75 inch or 4.45 cm) of vertical clearance between the chassis and any equipment directly above it or below.

**Caution**

Depending on your installation and co-located equipment power dissipation, it is recommended to have some air gap between chassis, if space allows, to reduce residual heating from one chassis to another.

- Have the cable-management bracket (used in four places on the Cisco ASR 1009-X Router and Cisco ASR 1006-X Router: upper half, lower half, and left and right sides) available if you plan to install it on the front of the chassis.
- An adequate chassis ground (earth) connection exists for your router chassis (see the "Attaching a Chassis Ground Connection" section).
- Always follow proper lifting practices as outlined in the "Chassis-Lifting Guidelines" section, when handling the chassis.

Attaching the Rear Rack-Mount Brackets

This section explains how to attach the rear rack-mount brackets to the chassis. Before installing the chassis in the rack, you must install the rack-mount brackets on each side of the chassis. The forward rack-mount brackets are already installed on the Cisco ASR 1009-X Router and Cisco ASR 1006-X Router when it arrives at your site.

The parts and tools required for installing the rack-mount brackets and cable-management brackets are listed in the *Tools and Equipment* section.

**Note**

The cable-management brackets are installed on the chassis after you install the chassis rack-mount brackets and mount the chassis in the rack.

If you are rack-mounting the chassis using the rear rack-mount brackets, then this type of installation provides for the chassis being recessed in the rack.

To install the rear rack-mount brackets on the Cisco ASR 1009-X Router and Cisco ASR 1006-X Router, perform the following steps:

Procedure

- Step 1** Locate the threaded holes on the rear side of the chassis. Make certain that you hold the rear rack-mount bracket with the ear and holes facing outward and towards the rear of the chassis (see callout number 4 in the following figure).

Figure 10: Location of the Rear Rack-Mount Brackets on the Cisco ASR 1009-X Router

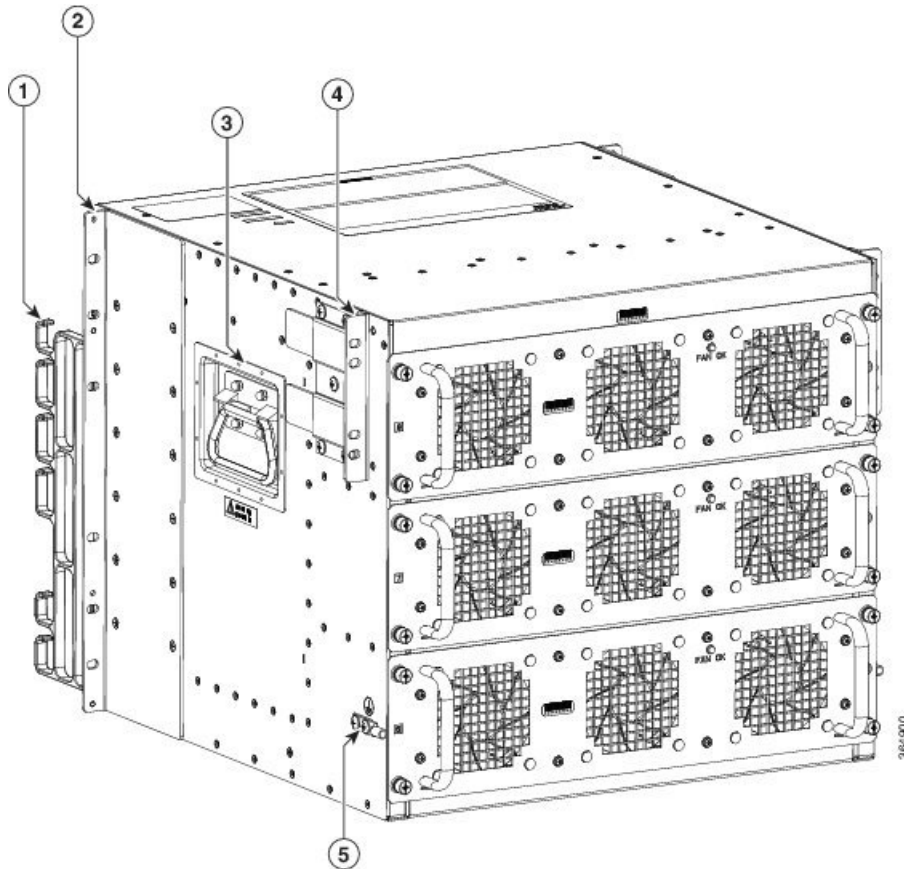

| | | | |
|---|---------------------------|---|--|
| 1 | Cable-management brackets | 2 | Forward rack-mount bracket ear and holes |
| 3 | Chassis handle | 4 | Rear rack-mount brackets |
| 5 | Chassis ground stud | | |

- Step 2** Position the rear rack-mount bracket top hole with the chassis second top hole from the back.
- Step 3** Insert and tighten the screws on one side.
- Step 4** After the bracket is secured to the side of the chassis, slide the two remaining components into the side rack-mount bracket.
- Step 5** Repeat Step 1 through Step 3 on the other side of the chassis. Use all the screws to secure the rear rack-mount brackets to the chassis.

Rack-Mounting the Cisco ASR 1009-X Router and Cisco ASR 1006-X Router

The Cisco ASR 1009-X Router and Cisco ASR 1006-X Router comes installed with front forward rack-mount brackets. The rear rack-mount brackets are optional and are shipped in the accessory kit along with a set of front rack-mount brackets. The chassis rack-mounting flanges must be secured directly to the chassis before you lift it into the rack.

Verifying Rack Dimensions

Before you install the chassis, measure the space between the vertical mounting flanges (rails) on your equipment rack to verify that the rack conforms to the measurements shown in the following table.

Figure 11: Verifying Equipment Rack Dimensions

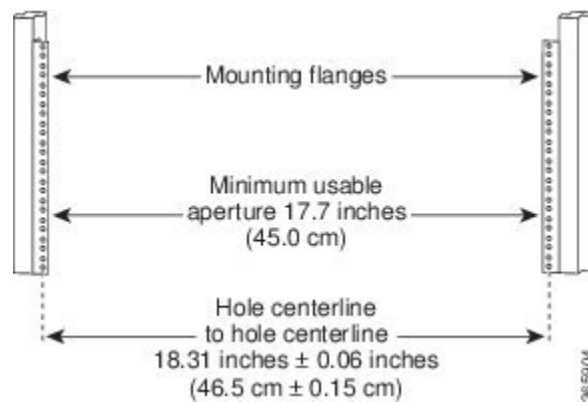

Procedure

-
- Step 1** Mark and measure the distance between two holes on the left and right mounting rails. The distance should measure 18.31 inches \pm 0.06 inches (46.5 cm \pm 0.15 cm).
- Note** Measure for pairs of holes near the bottom, middle and top of the equipment rack to ensure that the rack posts are parallel.
- Step 2** Measure the space between the inner edges of the left front and right front mounting flanges on the equipment rack. The space must be at least 17.7 inches (45 cm) to accommodate the chassis which is 17.25 inches (43.8 cm) wide and fits between the mounting posts on the rack.
-

Installing the Cisco ASR 1009-X Router and Cisco ASR 1006-X Router in a Rack

To mount the chassis in an equipment rack, you must secure the rack-mount brackets to two posts or mounting strips in the rack using the screws provided. Because the rack-mount brackets support the weight of the entire chassis, be sure to use all screws to fasten the two rack-mount brackets to the rack posts. You can install the Cisco ASR 1009-X Router or Cisco ASR 1006-X Router in an equipment rack using the forward rack-mount brackets or rear rack-mount brackets.

You can perform one of the following procedures to install the chassis in a rack:

- Two-post rack installation
- Four-post rack installation

Installing the Chassis Using the Forward Rack-Mount Brackets

**Caution**

Before you mount the Cisco ASR 1009-X Router and Cisco ASR 1006-X Router in a rack, make certain you read which rack-mount bracket ear holes to use when positioning the chassis in the rack. As a result of using the designated ear holes on the rack-mount bracket, the cable-management bracket installation will be made easier. For cable-management installation instructions, see the "Attaching the Cable-Management Bracket" section.

Determine where in the rack you want the chassis to be mounted. If you are mounting more than one chassis in the rack, then start from the bottom up or the center of the rack. The figure that follows shows the brackets attached to the chassis. Depending on the bracket holes you use, the chassis may protrude in the rack.

**Note**

The forward rack-mount brackets on the Cisco ASR 1009-X Router and Cisco ASR 1006-X Router arrive installed on the chassis and a spare set is included in the accessory kit. However, if you want to install a forward rack-mount bracket on the chassis, then see the instructions in this section.

The following figure shows the forward rack-mount brackets, callout number 2 and the rear rack-mount brackets, callout number 4, on the Cisco ASR 1009-X Router and Cisco ASR 1006-X Router.

Figure 12: Forward Rack-Mount Brackets on the Cisco ASR 1009-X Router

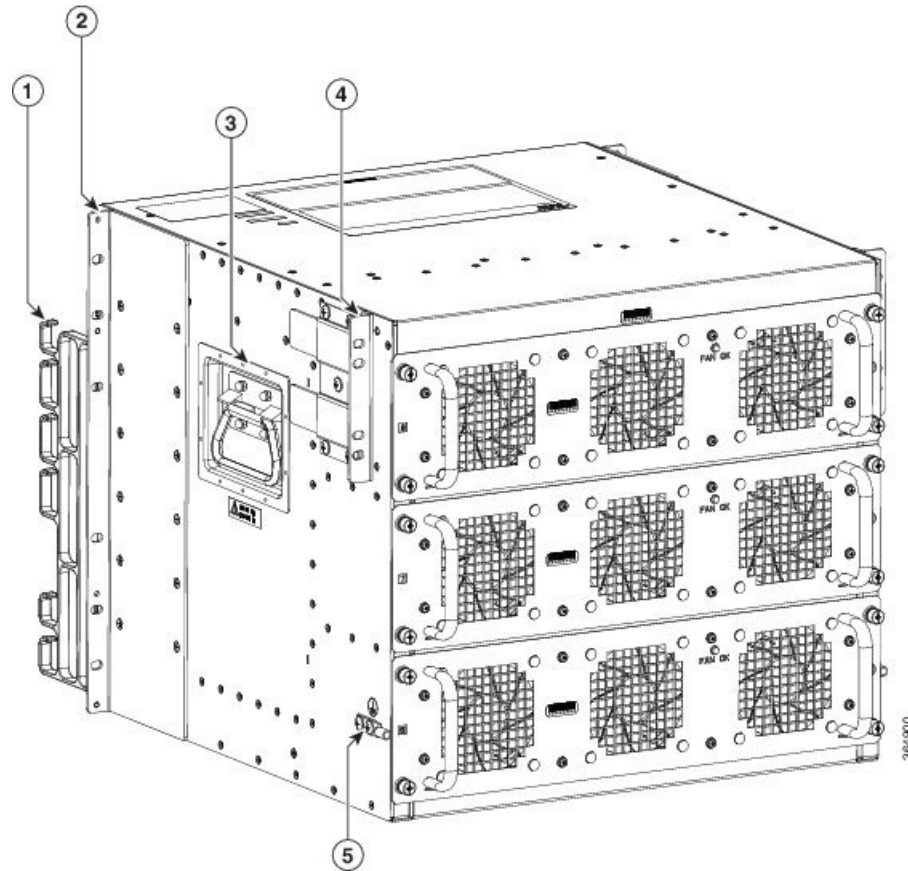

| | | | |
|---|---------------------------|---|--|
| 1 | Cable-management brackets | 2 | Forward rack-mount bracket ear and holes |
| 3 | Chassis handle | 4 | Rear rack-mount brackets |
| 5 | Chassis ground stud | | |



Warning To prevent bodily injury when mounting or servicing this unit in a rack, you must take special precautions to ensure that the system remains stable. The following guidelines are provided to ensure your safety:-This unit should be mounted at the bottom of the rack if it is the only unit in the rack.-When mounting this unit in a partially filled rack, load the rack from the bottom to the top with the heaviest component at the bottom of the rack.-If the rack is provided with stabilizing devices, install the stabilizers before mounting or servicing the unit in the rack. Statement 1006

We recommend that you allow at least 1 or 2 inches (2.54 or 5.08 cm) of vertical clearance between the router and any equipment directly above and below it.

To install the chassis in the rack using the forward rack-mount brackets, perform the following steps:

Procedure

- Step 1** On the chassis, ensure that all screw fasteners on the installed components are securely tightened.
- Step 2** Make sure that your path to the rack is unobstructed. If the rack is on wheels, ensure that the brakes are engaged or that the rack is otherwise stabilized. See the next sections on the types of racks you can use to install the chassis.
- Step 3** (Optional) Install a shelf in the rack to support the Cisco ASR 1009-X Router and Cisco ASR 1006-X Router. If you use a shelf, this will help support the chassis while you secure it to the rack.
- Step 4** With two people, lift the chassis into position between the rack posts.
- Step 5** Align the mounting bracket holes with the rack post holes and attach the chassis to the rack.
- Note** If you are using a shelf then raise the chassis to the level of the shelf. Let the bottom of the chassis rest on the brackets, but continue to support the chassis.
- Step 6** Position the chassis until the rack-mounting flanges are flush against the mounting rails on the rack.
- Step 7** Hold the chassis in position against the mounting rails and follow these steps:
- Insert the bottom screw into the third hole up from the bottom of the rack-mount ear and use a hand-held screwdriver to tighten the screw to the rack rail
- Tip** In the next step, insert the top screw diagonally from the bottom screw that you just attached. This helps with keeping the chassis in place.
- Insert the top screw into the third hole down from the top of the rack-mount ear and tighten the screw to the rack rail.
 - Insert a screw in the middle of the rack-mount bracket on both sides of the chassis.
 - Repeat these steps for the other side of the chassis.
- Note** As a result of using the specified rack-mount bracket ear holes, the cable-management bracket can be easily attached to the rack-mount bracket after the chassis is installed in the rack.
- Step 8** Tighten all screws on each side to secure the chassis to the equipment rack.
-

Installing the Chassis Using the Rear Rack-Mount Brackets

To install the chassis in the rack using the rear rack-mount brackets, perform the following steps:

Procedure

- Step 1** On the chassis, ensure that all screw fasteners on the installed components are securely tightened.
- Step 2** Make sure that your path to the rack is unobstructed. If the rack is on wheels, ensure that the brakes are engaged or that the rack is otherwise stabilized. See the next sections on the types of racks you can use to install the chassis.
- Step 3** (Optional) Install a shelf in the rack to support the Cisco ASR 1009-X Router and Cisco ASR 1006-X Router. If you use a shelf, this will help support the chassis while you secure it to the rack.
- Step 4** With two people, lift the chassis into position between the rack posts.
- Step 5** Align the mounting bracket holes with the rack post holes and attach the chassis to the rack.

Note If you are using a shelf then raise the chassis to the level of the shelf. Let the bottom of the chassis rest on the brackets, but continue to support the chassis.

- Step 6** Position the chassis until the rear rack-mounting flanges are flush against the mounting rails on the rack.
- Step 7** Hold the chassis in position against the mounting rails and insert all screws that were shipped in the accessory kit.
- Step 8** Tighten all screws on each side to secure the chassis to the equipment rack.

What to do next

You can install your Cisco ASR 1009-X Router or Cisco ASR 1006-X Router on a two-post rack or a four-post rack.

Two-Post Rack Installation

The Cisco ASR 1009-X Router or Cisco ASR 1006-X Router can be installed on a two-post 19-inch equipment rack. The following figure shows the Cisco ASR 1009-X Router and Cisco ASR 1006-X Router installed on a two-post rack.

Figure 13: Installing the Cisco ASR 1009-X Router on a Two-Post Rack

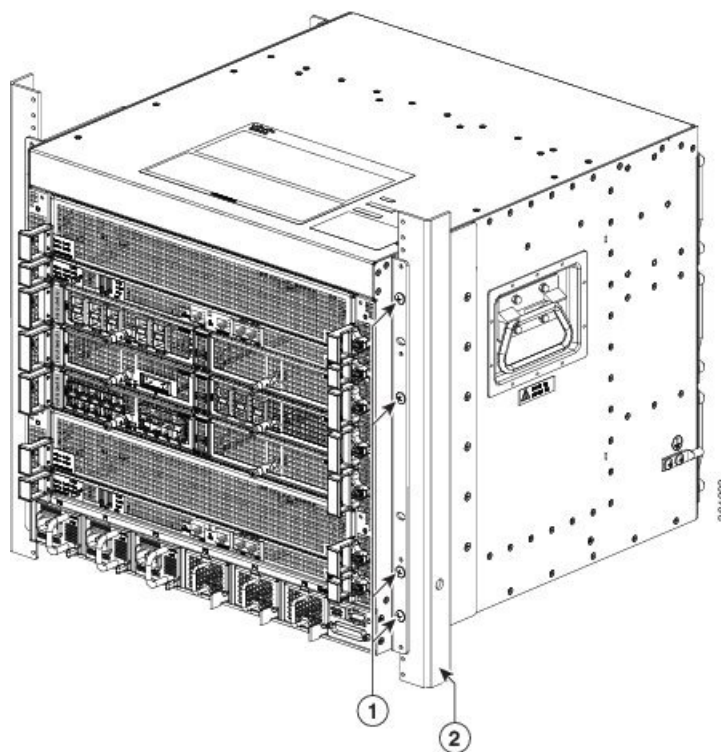

| | | | |
|---|--|---|------------------------------|
| 1 | Cisco ASR 1009-X Router and Cisco ASR 1006-X Router front rack-mount bracket | 2 | Two-post equipment rack rail |
|---|--|---|------------------------------|



Note Inner clearance (the width between the inner sides of the two posts or rails) must be at least 19 inches (48.26cm). The height of the chassis is 10.45 inches (26.543 cm). Airflow through the chassis is from front to back.



Caution If you are using a two-post rack, secure the rack to the floor surface to prevent tipping and avoid bodily injury and component damage.

To install the Cisco ASR 1009-X Router or Cisco ASR 1006-X Router on a two-post equipment rack, with the forward rack-mount brackets, follow these steps:

Procedure

-
- Step 1** Position the chassis so the front is closest to you and lift it carefully into the rack. To prevent injury, avoid any sudden twists or moves.
 - Step 2** Slide the chassis into the rack, pushing it back until the brackets meet the mounting strips or posts on both sides of the rack.
 - Step 3** Keeping the brackets flush against the posts or mounting strips, align the holes in the brackets with the holes on the rack or mounting strip.
 - Step 4** For each bracket, insert and tighten two screws to the rack on both sides.

Note Use the third hole up from the bottom of the rack-mount bracket and the third hole down from the top of the rack-mount bracket. See the figure above for the position and location of the ear holes on the rack-mount bracket.

What to do next

This completes the procedure for installing the chassis on a two-post rack. Proceed to the *Attaching the Ground Connection* section to continue the installation.

Four-Post Rack Installation

The Cisco ASR 1009-X Router or Cisco ASR 1006-X Router can be flush-mounted in a 19-inch equipment rack using the rack-mounting kit provided with your system. The Cisco ASR 1009-X Router or Cisco ASR 1006-X Router can be mounted into the rack using two recommended methods:

- Installing the chassis in an existing rack with equipment.
- Installing an empty chassis in a rack with no equipment installed.



Note Because the Cisco ASR 1009-X Router and Cisco ASR 1006-X Router are very heavy, it is recommended that the Router be installed at the bottom of the rack if you are planning to install more than one Cisco ASR 1009-X Router or Cisco ASR 1006-X Router in the same rack.

The following figure shows the Cisco ASR 1009-X Router installed on a four-post rack.

Figure 14: Installing the Cisco ASR 1009-X Router on a Four-Post Rack

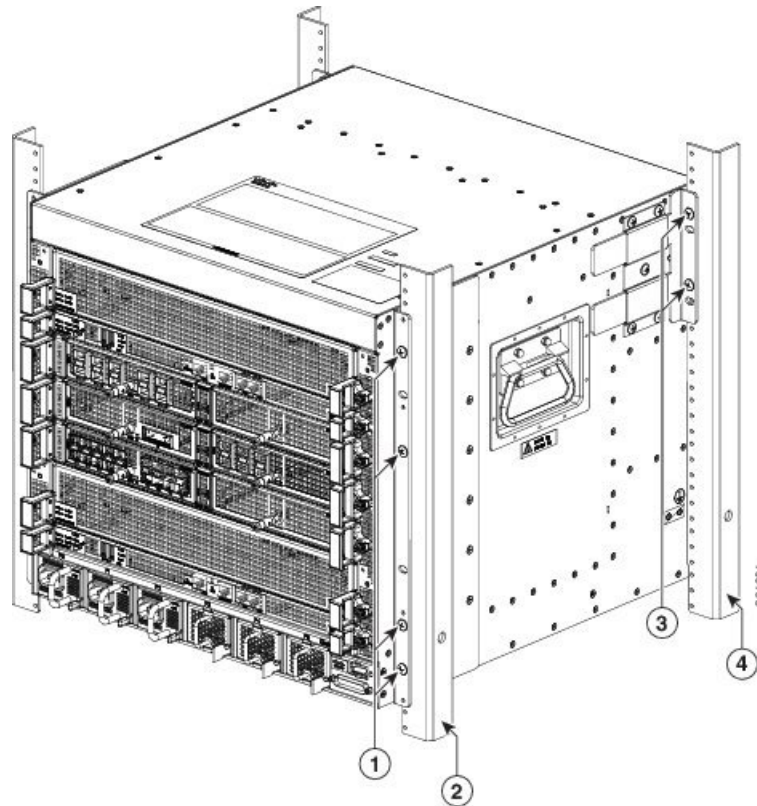

| | | | |
|---|--|---|---|
| 1 | Cisco ASR 1009-X Router front rack-mount bracket | 3 | Cisco ASR 1009-X Router rear rack-mount bracket |
| 2 | Two-post equipment rack rail | 4 | Four-post equipment rack rear rail |

When handling the chassis, always follow proper lifting practices. See the “Chassis-Lifting Guidelines” section.



Note Inner clearance (the width between the inner sides of the two posts or rails) must be at least 19 inches (48.26 cm). The height of the chassis is 22.75 inches (57.8 cm). Airflow through the chassis is from front to back.



Note Make sure the rack is stabilized.

Procedure

-
- Step 1** (Optional) Install a shelf in the rack to support the Cisco ASR 1009-X Router or Cisco ASR 1006-X Router. If you are using a shelf, then raise the chassis to the level of the shelf. Let the bottom of the chassis rest on the brackets, but continue to support the chassis. Using two people, lift the chassis into the rack using the side handles and grasping underneath the power supply bays.
- Step 2** Position the chassis until the rack-mounting flanges are flush against the mounting rails on the rack.
- Note** Use the third hole up from the bottom of the rack-mount bracket and the third hole down from the top of the rack-mount bracket. See the figure above for position and location of the ear holes on the rack-mount bracket.
- Step 3** Hold the chassis in position against the mounting rails while the second person finger-tightens a screw to the rack rails on each side of the chassis.
- Step 4** Finger-tighten 4 more screws to the rack rails on each side of the chassis.
- Step 5** Tighten all screws on each side to secure the chassis to the equipment rack.
- Step 6** Use a level to verify that the tops of the two brackets are level, or use a measuring tape to verify that both brackets are the same distance from the top of the rack rails.
-

What to do next

This completes the procedure for installing the chassis in the rack. Proceed to the [Attaching the Cable-Management Bracket, on page 60](#) section to continue the installation.

Attaching the Cable-Management Bracket

The cable-management brackets mount to each rack-mount bracket on the chassis to provide cable-management to both sides of the chassis (parallel with card orientation). These brackets are screw mounted to the rack-mount brackets to allow easy installation and removal of cables.

The cable-management brackets for the Cisco ASR 1009-X Router and Cisco ASR 1006-X Router are used in two places on the chassis. Each section contain four independent cable-management “U” type feature hooks with two screws each as shown in the figure that follows. For Cisco ASR 1000 SIPs, these brackets work in tandem with shared port adapter product feature cable-management device to allow installation and removal of adjacent cards without the need to remove cables.



-
- Note** Make certain that the cable-management bracket “U” type feature is facing upwards when you attach it to the chassis.
-

Follow these steps to attach two cable-management brackets to each side of the Cisco ASR 1009-X Router and Cisco ASR 1006-X Router in the rack:

Procedure

- Step 1** Align the cable-management bracket to the rack-mount bracket on each side of the Cisco ASR 1009-X Router and Cisco ASR 1006-X Router. The cable-management bracket aligns to the two smaller threaded holes of the chassis rack-mount bracket.
- Step 2** Using a Phillips screwdriver, insert the screws through cable-management bracket and into the chassis rack-mount and tighten the screws.

Note Use the package of screws that came with your chassis containing eight screws. The following figure shows the cable-management brackets attached to the chassis in a rack.

Figure 15: Cable-Management Brackets Installed on the Cisco ASR 1009-X Router

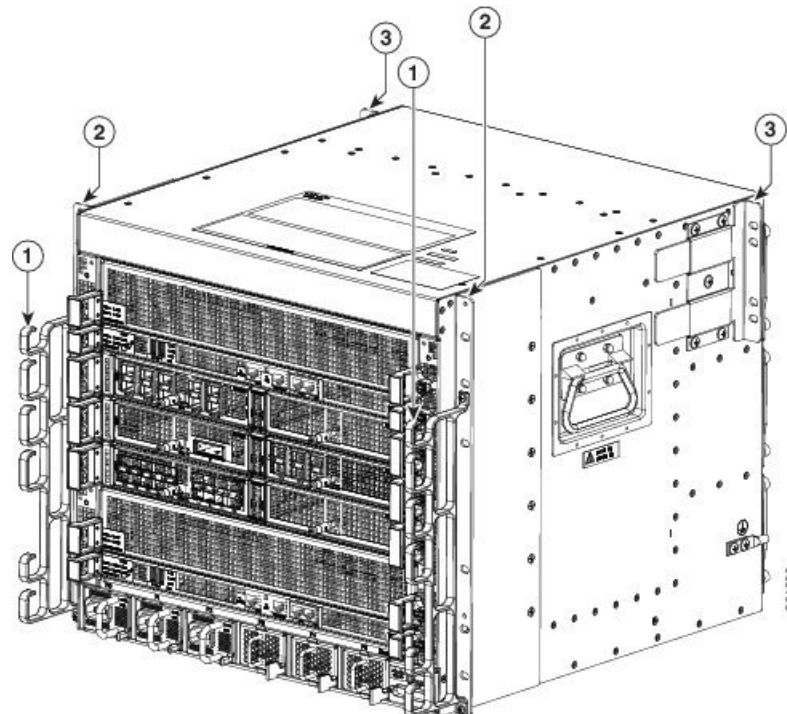

| | | | |
|---|----------------------------------|---|---------------------------------|
| 1 | Cable management bracket | 3 | Chassis rear rack mount bracket |
| 2 | Chassis front rack mount bracket | — | — |

Attaching the Chassis Ground Connection for Cisco ASR 1006-X Router and Cisco ASR 1009-X Router

Connecting the Cisco ASR 1006-X Router and Cisco ASR 1009-X Router chassis to ground is required for all DC powered installations and any AC powered installation where compliance with Telcordia grounding requirements is necessary.



Caution The dual-lug chassis stud must be installed, the SIP and SPA must be fully inserted and screwed in and earthed to prevent a potential hazard in a telecom line.

Have the recommended tools and supplies available before you begin this procedure.



Warning This equipment must be grounded. Never defeat the ground conductor or operate the equipment in the absence of a suitably installed ground conductor. Contact the appropriate electrical inspection authority or an electrician if you are uncertain that suitable grounding is available. Statement 1024

Before you connect power or turn on power to your chassis, you must provide an adequate chassis ground (earth) connection for the chassis. A chassis ground connector is provided on each Cisco ASR 1009-X Router and Cisco ASR 1006-X Router. There is a ground stud on the rear bottom of the chassis as shown in the figure below.

| | | | |
|---|--------------------|---|---------------|
| 1 | Chassis ground lug | 3 | Ground symbol |
| 2 | Grounding screws | — | — |

Recommended Tools and Supplies

The following tools, equipment, and supplies necessary to connect the system ground to the chassis:

- Phillips screwdriver
- Dual-lug chassis ground component
- Grounding wire

Use the following procedure to attach the grounding lug to the chassis ground connector on your chassis:

Procedure

-
- Step 1** Use the wire stripper to strip one end of the AWG #6 wire approximately 0.75 inches (19.05 mm).
- Step 2** Insert the AWG #6 wire into the wire receptacle on the grounding lug.
- Step 3** Use the crimping tool to carefully crimp the wire receptacle around the wire; this step is required to ensure a proper mechanical connection.
- Step 4** Attach the grounding lug with the wire so that the grounding wire does not overlap the power supply.
- Step 5** Locate the chassis ground connector on the bottom rear of the Cisco ASR 1009-X Router and Cisco ASR 1006-X Router.

The following figure shows how to attach the ground lug on the Cisco ASR 1009-X Router.

Figure 16: Attaching the Cisco ASR 1009-X Router Ground Connection

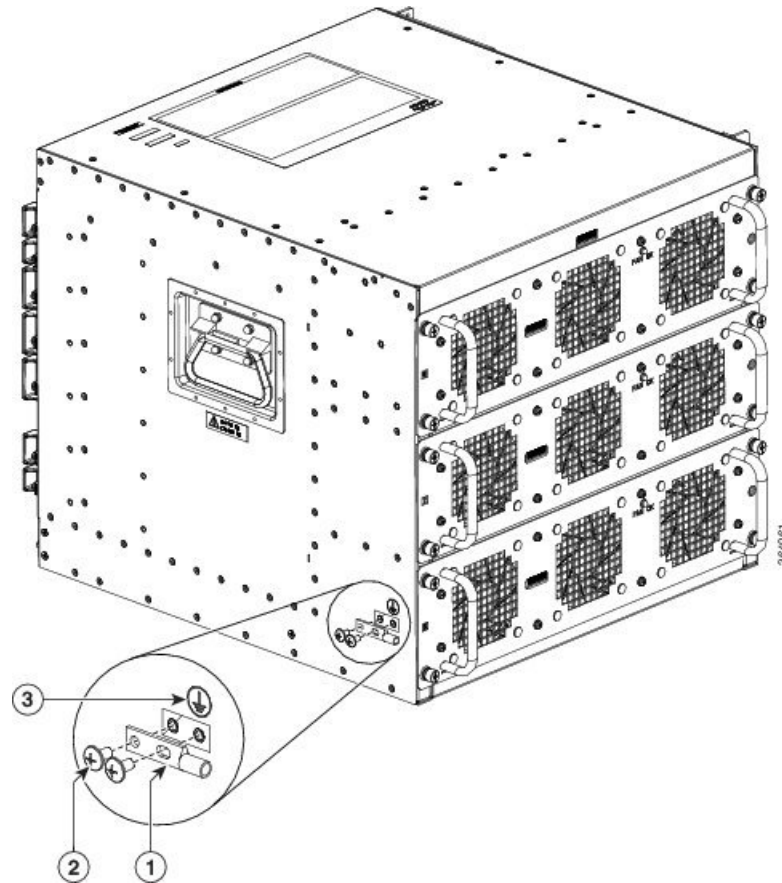

| | | | |
|---|--------------------|---|---------------|
| 1 | Chassis ground lug | 3 | Ground symbol |
| 2 | Grounding screws | — | — |

- Step 6** Insert the two screws through the holes in the grounding lug as shown in the figure above.
- Step 7** Use the Number 2 Phillips screwdriver to carefully tighten the screws until the grounding lug is held firmly to the chassis. Do not overtighten the screws.
- Step 8** Connect the opposite end of the grounding wire to the appropriate grounding point at your site to ensure an adequate chassis ground.

What to do next

This completes the procedure for attaching a chassis ground connection. Go to the following cabling sections for information on attaching cables.

Connecting the Shared Port Adapter Cables

The instructions for connecting the cables for the shared port adapter installed in the Cisco ASR 1009-X Router and Cisco ASR 1006-X Router are contained in the respective configuration documents for each port adapter. For example, if you are connecting the optical fiber cables for the PA-POS-OC3 port adapter, see PA-POS-OC3 Port Adapter Installation and Configuration at the following location:

http://www.cisco.com/en/US/partner/docs/interfaces_modules/port_adapters/install_upgrade/pos/pa-pos-oc3_install_config/paposoc3.html

Shared port adapter documents are also available on the Cisco Documentation DVD.

Connecting the Console and Auxiliary Port Cables

The Cisco ASR 1009-X Router and Cisco ASR 1006-X Router has a DCE-mode console port for connecting a console terminal and an auxiliary port for additional connections to your chassis. The auxiliary port can also be used for diagnostics.

In a fully redundant chassis, each Cisco ASR1000-RP2 is separately connected to each FP and I/O card slot over separate point-to-point connections of the system interconnect over the midplane. The selection of the active RP2s is made separately from the selection of the active embedded services processor.



Note For information about the Cisco ASR1000-RP3 module, see the [Cisco ASR 1000 Route Processor 3 Installation and Configuration Guide](#).

The following figures show the Cisco ASR 1000 Series Route Processor faceplate.

Figure 17: Cisco ASR1000-RP2 Faceplate LEDs

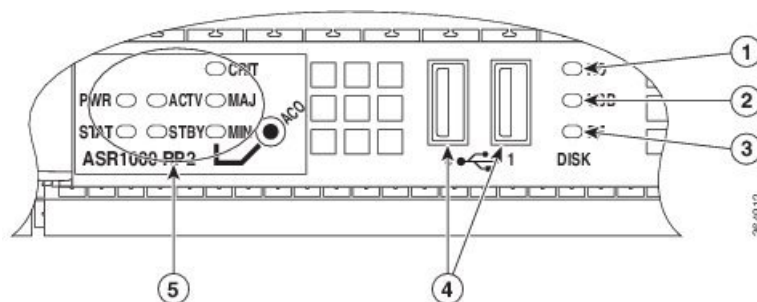

| | | | |
|---|----------------------------|---|------------------------|
| 1 | Internal hard drive LED | 4 | USB 0, USB 1 connector |
| 2 | External USB Flash LED | 5 | ASR1000-RP2 LEDs |
| 3 | Internal USB bootflash LED | — | — |

Figure 18: Cisco ASR 1000 Series Route Processor Faceplate Connectors

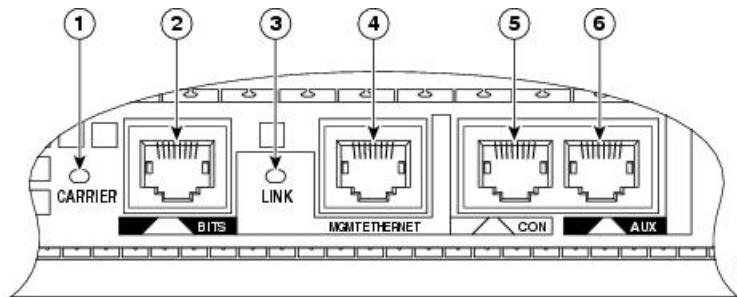

| | | | |
|---|----------------|---|-------------------------|
| 1 | CARRIER LED | 4 | MGMT Ethernet connector |
| 2 | BITS connector | 5 | CON connector |
| 3 | LINK LED | 6 | AUX connector |

The Cisco ASR 1009-X Router and Cisco ASR 1006-X Router uses RJ-45 ports for both the auxiliary port and the console port. Both the console and the auxiliary ports are asynchronous serial ports; any devices connected to these ports must be capable of asynchronous transmission.

Procedure

-
- Step 1** Before connecting a terminal to the console port, configure the terminal to match the chassis console port as follows: 9600 baud, 8 data bits, no parity, 1 stop bits (9600 8N1).
- Step 2** After you establish normal router operation, you can disconnect the terminal.
-

Connecting the Ethernet Management Port

When using the Fast Ethernet Management port (see callout 4 in the following figure) in the default mode (speed-auto and duplex-auto), the port operates in auto-MDI/MDI-X mode. The port automatically provides the correct signal connectivity through the Auto-MDI/MDI-X feature. The port automatically senses a crossover or straight-through cable and adapts to it.

However, when the Fast Ethernet Management port is configured to a fixed speed (10 or 100 Mbps) through command-line interface (CLI) commands, the port is forced to MDI mode.

When in a fixed-speed configuration and MDI mode:

- Use a crossover cable to connect to an MDI port
- Use a straight-through cable to connect to an MDI-X port



Note For information about the Cisco ASR1000-RP3 module, see the [Cisco ASR 1000 Route Processor 3 Installation and Configuration Guide](#).

Figure 19: Cisco ASR 1000 Series Route Processor Faceplate Connectors

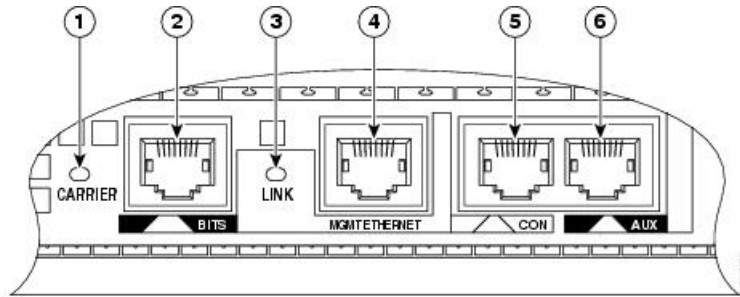

| | | | |
|---|----------------|---|-------------------------|
| 1 | CARRIER LED | 4 | MGMT Ethernet connector |
| 2 | BITS connector | 5 | CON connector |
| 3 | LINK LED | 6 | AUX connector |

Connecting Power to the Cisco ASR 1009-X Router and Cisco ASR 1006-X Router



Warning The covers are an integral part of the safety design of the product. Do not operate the unit without the covers installed. Statement 1077



Warning When you install the unit, the ground connection must always be made first and disconnected last. Statement 1046



Warning Before performing any of the following procedures, ensure that power is removed from the DC circuit. Statement 1003



Warning Only trained and qualified personnel should be allowed to install, replace, or service this equipment. Statement 1030

Connecting AC Input Power to Cisco ASR 1009-X Router and Cisco ASR 1006-X Router

Follow these steps to connect an AC-input power supply to the Cisco ASR 1009-X Router and Cisco ASR 1006-X Router:

Procedure

Step 1 Plug the power cable into the inlet.

Note For additional AC power cable strain relief, secure the cable to the power supply handle by inserting a nylon cable tie through the hole in the handle and around the cable.

Step 2 Plug the AC power supply cable into the AC power source.

Connecting DC Input Power to Cisco ASR 1009-X Router and Cisco ASR 1006-X Router

This section describes how to connect the DC power supply into the Cisco ASR 1009-X Router and Cisco ASR 1006-X Router. Before you begin to install the DC power supply into the Cisco ASR 1009-X Router and Cisco ASR 1006-X Router, read these important notices:

- The color coding of the DC input power supply leads depends on the color coding of the DC power source at your site. Typically, green or green/yellow is used for ground (GND), black is used for –48 V on negative (–) terminal and red is used for RTN on the positive (+) terminal. Make certain the lead color coding you choose for the DC input power supply matches lead color coding used at the DC power source.
- For DC input power cables, the wire gauge is based on the National Electrical Code (NEC) and local codes for 26 amp service at nominal DC input voltage (–40/–72 VDC). One pair of cable leads, source DC (–) and source DC return (+), are required for each power distribution unit (PDU). These cables are available from any commercial cable vendor. All DC input power cables for the chassis should be 10 gauge wire and cable lengths should match within 10 percent of deviation.

Each DC input power cable is terminated at the PDU by a cable lug. For more details, see the following figure.



Note DC input power cables must be connected to the PDU terminal studs in the proper positive (+) and negative (–) polarity. In some cases, the DC cable leads are labeled, which is a relatively safe indication of the polarity. However, you must verify the polarity by measuring the voltage between the DC cable leads. When making the measurement, the positive (+) lead and the negative (–) lead must always match the (+) and (–) labels on the power distribution unit.

Figure 20: DC Input Power Cable Lugs

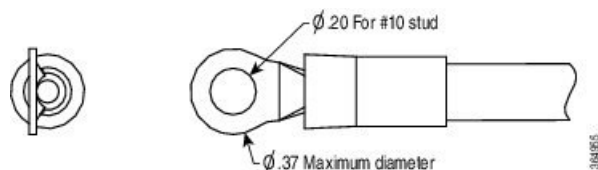



Note To avoid hazardous conditions, all components in the area where DC input power is accessible must be properly insulated. Therefore, before installing the DC cable lugs, be sure to insulate the lugs according to the manufacturer's instructions.



Warning When you install the unit, the ground connection must always be made first and disconnected last. Statement 1046

To connect the DC power supply, follow these steps:

Procedure

Step 1 Remove the plastic cover from the terminal block.

Caution Before you continue to install the terminal block ground wires, stop and perform Step 2. To prevent any contact with metal lead on the ground wire and the plastic cover.

Step 2 You must wrap the positive and negative lead cables with sleeving. Insulate the lug with shrink sleeving for each lead wire if using non-insulated crimp terminals. Sleeving is not required for insulated terminals.

Figure 21: DC Power Supply Terminal Block Ground Cable Lugs

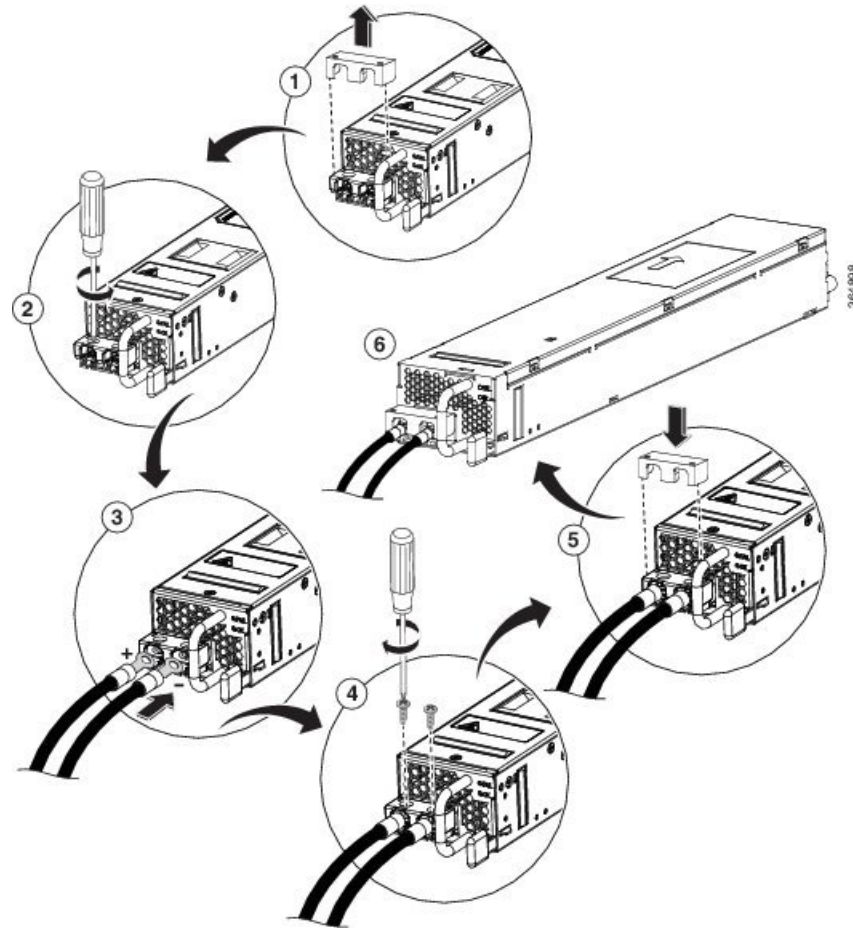

- Step 3** For easier cable-management, insert the negative lead cable first. Replace the ground lug with cable in the following order:
- Wire terminal
 - Screw with captive washer
- Step 4** Tighten the M3 Screw with captive washer to recommended torque of 5 in-lbs for the positive stud and wire.
- Note** Secure the wires coming in from the terminal block so that they cannot be disturbed by casual contact.
- Step 5** Replace the terminal block plastic cover. The plastic cover is slotted and keyed to fit correctly over the terminal block.
- Step 6** Switch the circuit breaker switch to the On (I) position.

Connecting a Terminal to the Cisco ASR 1000 Series RP Console Port

The Cisco ASR 1009-X and Cisco ASR 1006-X route processor has an asynchronous serial (EIA/TIA-232) RJ-45 console port labeled CON on its front panel as shown in the figure below, callout 5. You can connect this port to most types of video terminals through use of the console cable kit that is included with your Cisco ASR 1009-X Router and Cisco ASR 1006-X Router. The console cable kit contains:

- One RJ-45 to RJ-45 crossover cable
- One RJ-45 to DB-25 (female) adapter
- One RJ-45 to DB-9 (female) adapter

A crossover cable reverses pin connections from one end to the other. In other words, it connects pin 1 (at one end) to pin 8 (at the other end), pin 2 to pin 7, pin 3 to pin 6, and so on. You can identify a crossover cable by comparing the two modular ends of the cable. Hold the cable ends in your hand, side-by-side, with the tabs at the back. Ensure that the wire connected to the outside (left) pin of the left plug (pin 1) is the same color as the wire connected to the outside (right) pin of the right plug (pin 8).

Use the following procedure to connect a video terminal to the console port on a route processor.



Note Each Cisco ASR 1000 Series Route Processor must have a console port connection (typically to a terminal server) if you are running a redundant configuration in the chassis.

Users using the console port to access the router are automatically directed to the IOS command-line interface, by default.

If a user is trying to access the router through the console port and sends a break signal (a break signal can be sent by entering Ctrl-C or Ctrl-Shift-6, or by entering the send break command at the Telnet prompt) before connecting to the IOS command-line interface, the user is directed into diagnostic mode by default if the non-RPIOS sub-packages can be accessed.

These settings can be changed by configuring a transport map for the console port and applying that transport map to the console interface.

The following figure shows the Cisco ASR 1000 Series route processor console port connectors.



Note For information about the Cisco ASR1000-RP3 module, see the [Cisco ASR 1000 Route Processor 3 Installation and Configuration Guide](#).

Figure 22: Cisco ASR 1000 Series Route Processor Console Port Connectors

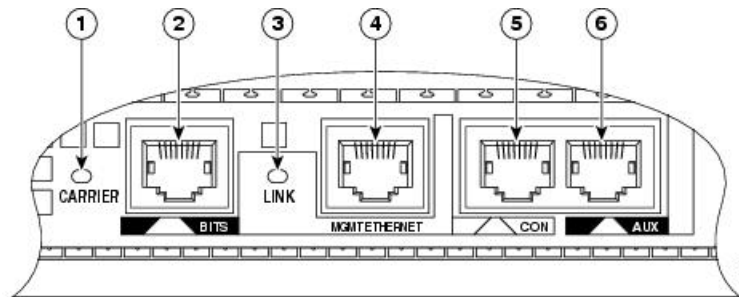

| | | | |
|---|----------------|---|-------------------------|
| 1 | CARRIER LED | 4 | MGMT Ethernet connector |
| 2 | BITS connector | 5 | CON connector |
| 3 | LINK LED | 6 | AUX connector |

Procedure

-
- Step 1** Connect one end of the RJ-45 cables to the serial RJ-45 port (CON) on the Cisco ASR1000-RP2 route processor.
- Step 2** Run the cable up and through the cable-management bracket and connect the other end of the RJ-45 cable to the RJ-45 adapter,
- Step 3** Connect the adapter to your video terminal to complete the cable connection.
- Step 4** Power on your video terminal.
- Step 5** Configure your video terminal to match the following default console port settings: 9600 baud, 8 data bits, No parity generation or checking, 1 stop bit, and No flow control.
- Step 6** Go to the [Connecting the System Cables, on page 71](#) section to continue the installation.
-

Connecting the System Cables

Keep the following guidelines in mind when connecting external cables to the Cisco ASR 1009-X Router and Cisco ASR 1006-X Router:

- To reduce the chance of interference, avoid crossing high-power lines with any interface cables.
- Verify all cabling limitations (particularly distance) before powering on the system.



CHAPTER 6

Cisco ASR 1009-X Router and Cisco ASR 1006-X Router Power Up and Initial Configuration

This chapter guides you through a basic router configuration, which is sufficient for you to access your network. Complex configuration procedures are beyond the scope of this publication and can be found in the modular configuration and modular command reference publications in the Cisco IOS software configuration documentation set that corresponds to the software release installed on your Cisco hardware.

To configure the Cisco ASR 1009-X Router or Cisco ASR 1006-X Router from a console, you need to connect a terminal to the router console port.

This chapter contains the following topics:

- [Checking Conditions Prior to System Startup, on page 73](#)
- [Powering Up the Cisco ASR 1009-X Router or Cisco ASR 1006-X Router, on page 74](#)
- [Verifying Power Supply Operation, on page 77](#)
- [Configuring the Cisco ASR 1009-X Router or Cisco ASR 1006-X Router at Startup, on page 79](#)
- [Powering Off the Cisco ASR 1009-X Router or Cisco ASR 1006-X Router Safely, on page 81](#)

Checking Conditions Prior to System Startup

Ensure that the following conditions are addressed before starting up the router:

- The shared port adapter is inserted in its slot.
- The network interface cable is connected.
- The optional Fast Ethernet Management port cable is installed.
- The chassis is securely mounted and grounded.
- The power and interface cables are connected.
- Your PC with terminal emulation program (hyperTerminal or equivalent) is connected to the console port and powered up.
- Your PC terminal emulation program is configured for 9600 baud, 8 data bits, 1 stop bit, no parity, and flow control is set to none.
- You have selected passwords for access control.

- Captive installation screws are tight on all removable components.
- The console terminal is turned on.
- You have determined the IP addresses for the Ethernet and serial interfaces.
- Empty card slots or card bays are filled with card blanks. This ensures proper air flow through the chassis and electromagnetic compatibility (EMC).

You are now ready to start your router.

Powering Up the Cisco ASR 1009-X Router or Cisco ASR 1006-X Router

Make certain that all card slots and compartments are closed off. Install blank faceplates on any empty slots. Always have power supply slots filled. If you leave a power supply slot uncovered, then you risk exposure to hazardous voltages on the power pins on the midplane.

After installing your Cisco ASR 1009-X Router or Cisco ASR 1006-X Router, and connecting cables, start the router.



Caution Blank faceplates and cover panels serve three important functions: they prevent exposure to hazardous voltages and currents inside the chassis; they contain electromagnetic interference (EMI) that might disrupt other equipment; and they direct the flow of cooling air through the chassis. Do not operate the system unless all cards, faceplates, front covers, and rear covers are in place. Statement 1029

You are now ready to power on the system for the first time. Follow these steps.

Procedure

- Step 1** Before you power on, make sure that:
- The AC cord is plugged into the AC power inlet.
 - All cables are connected.
 - Your computer is powered up and connected.

Note To view the boot sequence, you must have a console connection to the Cisco ASR 1009-X Router or Cisco ASR 1006-X Router before it powers up.

- Step 2** Move the power switch to the ON position. Listen for the fans; you should immediately hear them operating.

- Step 3** Depending on your installation, some LEDs on the front of the chassis and on installed modules also come on.

Caution Do not press any keys on the keyboard until the messages stop and the SYS PWR LED is solid green. Any keys pressed during this time are interpreted as the first command typed when the messages stop, which might cause the router to power off and start over. It takes a few minutes for the messages to stop.

Note This is only an example of what can display. The system boots differently depending upon the configuration that ships with your system.

Step 4 Observe the initialization process. When the system boot is complete (the process takes a few seconds), the Cisco ASR 1000 RP2 begins to initialize. The following example shows the loading of the default system boot image:

Example:

```
rommon 1 >
rommon 1 > boot
Located rp_super.ppc.nader.5g.evfc.bin
Image size 211681484 inode num 12, bks cnt 51681 blk size 8*512
#####
Boot image size = 211681484 (0xc9e00cc) bytes

Using midplane macaddr
Package header rev 0 structure detected
Calculating SHA-1 hash...done
validate_package: SHA-1 hash:
    calculated 479a7d62:6c128ba8:3616b8da:93cb3224:5c1aeb34
    expected   479a7d62:6c128ba8:3616b8da:93cb3224:5c1aeb34
Image validated

PPC/IOS XE loader version: 0.0.3
loaded at:      00800000 0D1E2004
zimage at:     00807673 009B8C69
initrd at:     009B9000 01006219
isord at:      01007000 0D1DF800
avail ram:     00400000 00800000

Kernel load:
Uncompressing image... dst: 00000000 lim: 00400000 start: 00807673 size: 001B15F6...done.
Now booting the IOS XE kernel
    Restricted Rights Legend

Use, duplication, or disclosure by the Government is
subject to restrictions as set forth in subparagraph
(c) of the Commercial Computer Software - Restricted
Rights clause at FAR sec. 52.227-19 and subparagraph
(c) (1) (ii) of the Rights in Technical Data and Computer
Software clause at DFARS sec. 252.227-7013.

    cisco Systems, Inc.
    170 West Tasman Drive
    San Jose, California 95134-1706

Router# show version
Cisco IOS Software, IOS-XE Software (PPC_LINUX_IOSD-ADVENTERPRISEK9-M), Version 12.2(33)XNA,
RELEASE SOFTWARE
Technical Support: http://www.cisco.com/techsupport
Copyright (c) 1986-2008 by Cisco Systems, Inc.
Compiled Thu 01-May-08 00:29 by mcpre
Cisco IOS-XE software, Copyright (c) 1986-2008 by Cisco Systems, Inc.
All rights reserved. Certain components of Cisco IOS-XE software are
licensed under the GNU General Public License (GPL) Version 2.0. The
software code licensed under GPL Version 2.0 is free software that comes
with ABSOLUTELY NO WARRANTY. You can redistribute and/or modify such
GPL code under the terms of GPL Version 2.0. For more details, see the
```

documentation or License Notice file accompanying the IOS-XE software, or the applicable URL provided on the flyer accompanying the IOS-XE software.
 A summary of U.S. laws governing Cisco cryptographic products may be found at:
<http://www.cisco.com/wwl/export/crypto/tool/stqrg.html>

If you require further assistance please contact us by sending email to export@cisco.com.

cisco ASR1002 (RP2) processor with 541737K/6147K bytes of memory.
 4 Gigabit Ethernet interfaces
 32768K bytes of non-volatile configuration memory.
 1869396K bytes of physical memory.
 7798783K bytes of eUSB flash at bootflash:.

--- System Configuration Dialog ---

Would you like to enter the initial configuration dialog? [yes/no]: no

Press RETURN to get started!

```
*Feb 19 17:34:27.361: % Error opening nvram:/ifIndex-table No such file or directory
*Feb 19 17:34:28.235: %ASR1000_MGMTVRF-6-CREATE_SUCCESS_INFO: Management vrf Mgmt-intf
created with ID 4085, ipv4 table-id 0xFF5, ipv6 table-id 0x1E000001
*Feb 19 17:34:29.720: %PARSER-4-BADCFG: Unexpected end of configuration file.

*Feb 19 17:34:29.809: %NETCLK-5-NETCLK_MODE_CHANGE: Network clock source not available.
The network clock has changed to freerun

*Feb 19 17:34:10.138: %CPPHA-7-SYSREADY: F0: cpp_ha: CPP client process FMAN-FP (5 of 5)
ready.
*Feb 19 17:34:29.824: %LINK-3-UPDOWN: Interface GigabitEthernet0, changed state to up
*Feb 19 17:34:10.269: %IOSXE-6-PLATFORM: F0: cpp_cp:
cpp_mlp_svr_client_bind: cpp_mlp_svr_ifm_init() successful
*Feb 19 17:34:10.362: %CPPHA-7-START: F0: cpp_ha: CPP 0 preparing image
/usr/cpp/bin/cpp-mcplo-ucode
*Feb 19 17:34:10.473: %CPPHA-7-START: F0: cpp_ha: CPP 0 startup init image
/usr/cpp/bin/cpp-mcplo-ucode
*Feb 19 17:34:14.688: %CPPHA-7-START: F0: cpp_ha: CPP 0 running init image
/usr/cpp/bin/cpp-mcplo-ucode
*Feb 19 17:34:14.919: %CPPHA-7-READY: F0: cpp_ha: CPP 0 loading and initialization complete
*Feb 19 17:34:14.919: %CPPHA-6-SYSINIT: F0: cpp_ha: CPP HA system configuration start.
*Feb 19 17:34:15.179: %IOSXE-6-PLATFORM: F0: cpp_cp:
Process CPP_PFILTER_EA_EVENT_API_CALL_REGISTER
*Feb 19 17:34:15.286: %CPPHA-6-SYSINIT: F0: cpp_ha: CPP HA system enabled.
*Feb 19 17:34:15.287: %CPPHA-6-SYSINIT: F0: cpp_ha: CPP HA system initializaton complete.
*Feb 19 17:34:30.823: %LINEPROTO-5-UPDOWN: Line protocol on Interface GigabitEthernet0,
changed state to down
*Feb 19 17:35:12.865: %LINK-5-CHANGED: Interface GigabitEthernet0/0/0,
changed state to administratively down
*Feb 19 17:35:12.865: %LINK-5-CHANGED: Interface GigabitEthernet0/0/1,
changed state to administratively down
*Feb 19 17:35:12.865: %LINK-5-CHANGED: Interface GigabitEthernet0/0/2,
changed state to administratively down
*Feb 19 17:35:12.865: %LINK-5-CHANGED: Interface GigabitEthernet0/0/3,
changed state to administratively down
*Feb 19 17:35:13.865: %LINEPROTO-5-UPDOWN: Line protocol on Interface GigabitEthernet0/0/0,
changed state to down
*Feb 19 17:35:13.865: %LINEPROTO-5-UPDOWN: Line protocol on Interface GigabitEthernet0/0/1,
changed state to down
*Feb 19 17:35:13.866: %LINEPROTO-5-UPDOWN: Line protocol on Interface GigabitEthernet0/0/2,
```

```

changed state to down
*Feb 19 17:35:13.866: %LINEPROTO-5-UPDOWN: Line protocol on Interface GigabitEthernet0/0/3,

changed state to down
*Feb 19 17:35:19.167: %ASR1000_OIR-6-REMSPA: SPA removed from subslot 0/0, interfaces
disabled
*Feb 19 17:35:19.171: %ASR1000_OIR-6-INSCARD: Card (fp) inserted in slot F0
*Feb 19 17:35:19.171: %ASR1000_OIR-6-ONLINECARD: Card (fp) online in slot F0
*Feb 19 17:35:19.187: %ASR1000_OIR-6-INSCARD: Card (cc) inserted in slot 0
*Feb 19 17:35:19.187: %ASR1000_OIR-6-ONLINECARD: Card (cc) online in slot 0
*Feb 19 17:35:19.189: %ASR1000_OIR-6-INSSPA: SPA inserted in subslot 0/0
*Feb 19 17:35:19.452: %SYS-5-RESTART: System restarted --
Cisco IOS Software, IOS-XE Software (PPC_LINUX_IOSD-ADVENTERPRISEK9-M), Version 12.2(33)XNA,
RELEASE SOFTWARE
Technical Support: http://www.cisco.com/techsupport
Copyright (c) 1986-2008 by Cisco Systems, Inc.
Compiled Thu 20-Dec-07 18:10 by mcpre
*Feb 19 17:35:19.455: %SYS-6-BOOTTIME: Time taken to reboot after reload = 78809 seconds
*Feb 19 17:35:19.551: %CRYPTO-6-ISAKMP_ON_OFF: ISAKMP is OFF
*Feb 19 17:35:19.551: %CRYPTO-6-ISAKMP_ON_OFF: ISAKMP is OFF
*Feb 19 17:35:21.669: %DYNCMD-7-CMDSET_LOADED: The Dynamic Command set has been loaded from

the Shell Manager
*Feb 19 17:35:22.221: %CRYPTO-6-ISAKMP_ON_OFF: ISAKMP is OFF
Router>

```

- Step 5** During the boot process, observe the system LEDs. The LEDs on the shared port adapter go ON and OFF in irregular sequence. They may go on, go out, and go on again for a short time. On the router, the green STATUS LED comes on and stays on.

Verifying Power Supply Operation

Follow this procedure to verify power supply is operating correctly.

Procedure

- Step 1** Check that the power supply LEDs are:
- OK is green
 - FAIL is not illuminated
- Step 2** To ensure that the power supply state is OK, type the **show platform** command. This output sample is from the Cisco ASR 1009-X Router.
- The following output displays:

Example:

```

Router#show platform
Chassis type: ASR1009-X
Slot      Type                State                Insert time (ago)
-----
0         ASR1000-MIP100      ok                   00:11:18
0/0      EPA-1X100GE         ok                   00:09:14
1         ASR1000-MIP100      ok                   00:11:18

```

```

1/0      EPA-10X10GE      ok      00:09:14
R0       ASR1000-RP2      ok, active 00:11:18
R1       ASR1000-RP2      ok, standby 00:11:18
F0       ASR1000-ESP160   ok, active 00:11:18
F1       ASR1000-ESP160   ok, standby 00:11:18
P0       ASR1000X-AC-1100W ok      00:09:14
P1       ASR1000X-AC-1100W ok      00:09:14
P2       ASR1000X-AC-1100W ok      00:09:14
P3       ASR1000X-AC-1100W ps, fail 00:09:14
P4       ASR1000X-AC-1100W ps, fail 00:09:14
P5       ASR1000X-AC-1100W ps, fail 00:09:14
P6       ASR1000X-FAN     ok      00:09:14
P7       ASR1000X-FAN     ok      00:09:14
P8       ASR1000X-FAN     ok      00:09:14
Slot     CPLD Version      Firmware Version
-----
0        15072100          12.2(20150730:165420) [gcasheek-rmon...
1        15072100          12.2(20150730:165420) [gcasheek-rmon...
R0       14111801          15.2(1r)S
R1       14111801          15.2(1r)S
F0       12092500          15.2(4r)S1
F1       12050100          12.2(20120509:191721) [gschnorr-rele...

```

If the LEDs indicate a power problem or the power supply state is **ps, fail**, then contact a customer service representatives for assistance or additional instructions.

Verifying the Front Panel LEDs

The front-panel indicator LEDs provide power, activity, and status information useful during bootup. For more detailed information about the LEDs, see [Cisco ASR 1009-X Router and Cisco ASR 1006-X Router Power Supply LEDs, on page 22](#).

Verifying the Hardware Configuration

To display and verify the hardware features, enter the following commands:

- **show version**—Displays the system hardware version; the installed software version; the names and sources of configuration files; the boot images; and the amount of installed DRAM, NVRAM, and flash memory.
- **show diag chassis**—Displays the IDPROM information for the assemblies in the chassis.
- **show diag slot/subslot**—Displays the IDPROM information for the subassemblies in the chassis.

Checking Hardware and Software Compatibility

To check the minimum software requirements of the Cisco IOS software with the hardware installed on your Cisco ASR 1000 Series Routers, Cisco maintains the Software Advisor tool on Cisco.com. This tool does not verify whether Cisco ASR 1000 Series SIPs or SPAs within a system are compatible; but the tool provides the minimum Cisco IOS requirements for individual hardware modules and components.



Note To access this tool, you must have a Cisco.com login account.

To access the Software Advisor, click **Login** at Cisco.com, type **Software Advisor** in the search box, and click **Go**. Click the link for the Software Advisor Tool.

Choose a product family or enter a specific product number to search for the minimum supported software needed for your hardware.

Configuring the Cisco ASR 1009-X Router or Cisco ASR 1006-X Router at Startup

This section explains how to create a basic running configuration for your Cisco ASR 1009-X Router or Cisco ASR 1006-X Router.



Note You need to acquire the correct network addresses from your system administrator or consult your network plan to determine correct addresses before you can complete the router configuration.

Before continuing the configuration process, check the current state of the router by entering the **show version** command. The **show version** command displays the release of Cisco IOS software that is available on the router.

For information on modifying the configuration after you create it, see the Cisco IOS configuration and command reference guides.

To configure a Cisco ASR 1009-X Router or Cisco ASR 1006-X Router from the console, you must connect a terminal or terminal server to the console port. To configure the Cisco ASR 1009-X Router or Cisco ASR 1006-X Router over your management Ethernet, you must have the router's IP address available.

Using the Console Interface

To access the command line interface using the console, follow these steps:

Procedure

Step 1 Your system is booting and if you answer No, at the prompt:

Example:

```
--- System Configuration Dialog ---  
Would you like to enter the initial configuration dialog? [yes/no]: no
```

Step 2 Then Press Return to enter user EXEC mode. The following prompt appears:

```
Router>
```

Step 3 From user EXEC mode, enter the enable command as shown in the following example:

```
Router> enable
```

Step 4 At the password prompt, enter your system password. If an enable password has not been set on your system, this step may be skipped. The following example shows entry of the password called *enablepass* :

Password: **enablepass**

Step 5 When your enable password is accepted, the privileged EXEC mode prompt appears: Router#

Step 6 You now have access to the CLI in privileged EXEC mode and you can enter the necessary commands to complete your desired tasks. To exit the console session, enter the quit command as shown in the following example:

```
Router# quit
```

Configuring Global Parameters

When you first start the setup program, you must configure the global parameters. These parameters are used for controlling system-wide settings. Perform the following steps to enter the global parameters:

Procedure

Step 1 Connect a console terminal to the console port, and then boot the router.

Note This is only an example of the output display; prompts may vary.

When you see this information, you have successfully booted your router:

Example:

```
Restricted Rights Legend
```

```
Use, duplication, or disclosure by the Government is
subject to restrictions as set forth in subparagraph
(c) of the Commercial Computer Software - Restricted
Rights clause at FAR sec. 52.227-19 and subparagraph
(c) (1) (ii) of the Rights in Technical Data and Computer
Software clause at DFARS sec. 252.227-7013.
```

```

      cisco Systems, Inc.
      170 West Tasman Drive
      San Jose, California 95134-1706

```

```
.
.
.
```

```
--- System Configuration Dialog ---
```

```
Would you like to enter the initial configuration dialog? [yes/no]: yes
```

```
Press RETURN to get started!
```

Step 2 The first sections of the configuration script appear only at an initial system startup. On subsequent uses of the setup facility, the script begins with a System Configuration Dialog as shown below. When asked if you would like to enter the initial configuration dialog, enter yes.

Example:

```
Would you like to enter the initial configuration dialog? [yes/no] yes
At any point you may enter a question mark '?' for help.
Use ctrl-c to abort configuration dialog at any prompt.
Default settings are in square brackets '[]'.
Basic management setup configures only enough connectivity for
```

management of the system, extended setup will ask you to configure each interface on the system.

Note Basic management setup configures enough connectivity for managing the system; extended setup will ask you to configure each interface on the system. For detailed information about setting global parameters, see the *Cisco ASR 1000 Series Aggregation Services Routers Software Configuration Guide*.

Checking the Running Configuration Settings

To check the value of the settings you have entered, enter the `show running-config` command at the Router# prompt:

```
Router# show running-config
```

To review changes you make to the configuration, use the EXEC mode `show startup-config` command to see the changes and copy run-start stored in NVRAM.

Saving the Running Configuration to NVRAM

To store the configuration or changes to your startup configuration in NVRAM, run the `copy running-config startup-config` command:

```
Router# copy running-config startup-config
```

Using this command saves the configuration settings that you created in the router using configuration mode and the setup facility. If you fail to do this, your configuration will be lost the next time you reload the router.

If you are using the Cisco ASR 1009-X Router or Cisco ASR 1006-X Router, see the caution notice in the [Powering Off the Cisco ASR 1009-X Router or Cisco ASR 1006-X Router Safely, on page 81](#).

Powering Off the Cisco ASR 1009-X Router or Cisco ASR 1006-X Router Safely

This section explains how to shut down the Cisco ASR 1009-X Router or Cisco ASR 1006-X Router. It is recommended that before turning off all power to the chassis, you issue the `reload` command. This ensures that the operating system cleans up all the file systems. After the reload operation is complete, then the Cisco ASR 1009-X Router or Cisco ASR 1006-X Router can be powered off safely.

**Caution**

If you are going to power cycle a Cisco ASR 1009-X Router, we recommend that you first perform a graceful reload on the router. Power cycling the router without first performing a graceful reload might cause a loss of data stored in the NVRAM. In other words, the configuration file might be lost. Note that this is not observed when a power failure occurs because each active power supply in the two power supply zones is power cycled at the same time during a power failure. If there is a chance that the router might be power cycled without a graceful reload, we recommend that you use the **boot config file-system:configuration-file nvbypass** command to specify a file system other than the NVRAM for storing the configuration file. The following are examples: Router(config)# **boot config harddisk:config_file.cfg nvbypass** Router(config)# **boot config bootflash:configuration_data.cfg nvbypass**

To remove power from the Cisco ASR 1009-X Router or Cisco ASR 1006-X Router safely, follow this procedure and see the examples:

Procedure

Step 1 Slip on the ESD-preventive wrist strap that was included in the accessory kit.

Step 2 Enter the **reload** command.

Step 3 Confirm the reload command.

Example:

```
Router# reload
Proceed with reload? [confirm]
Aug 17 00:06:47.051 R0/0: %PMAN-5-EXITACTION:
Process manager is exiting: prs exit with reload chassis code
```

Step 4 After confirming the reload command, wait until the system bootstrap message displays before powering off the system.

Example:

```
System Bootstrap, Version 12.2(33r)XN2, RELEASE SOFTWARE (fc1)
Technical Support: tap://www.cisco.com/techsupport
Copyright (c) 2008 by cisco Systems, Inc.
Current image running: Boot ROM0
Last reset cause: LocalSoft
ASR1000-RP2 platform with 4194303 Kbytes of main memory
mcp-6ru-1-rp0-rommon 1>
```

Step 5 Remove any power cables from the Cisco ASR 1009-X Router or Cisco ASR 1006-X Router.

- a) For power supplies with a circuit breaker switch, position the switch to the Off (O) position.
- b) For power supplies with a Standby switch, place the Standby switch in the Standby position.

Note After powering off the router, wait for a minimum of 30 seconds before powering it on again.



CHAPTER 7

Removing and Replacing Cisco ASR 1009-X Router and Cisco ASR 1006-X Router FRUs

This chapter contains the following topics:

- [Removing and Replacing Power Supplies, on page 83](#)
- [Removing and Replacing Fans, on page 89](#)

Removing and Replacing Power Supplies

The following sections describes the procedures for removing and replacing the Cisco ASR 1009-X Router and Cisco ASR 1006-X Router power supplies.



Note The Cisco ASR 1009-X Router and Cisco ASR 1006-X Router have redundant power supplies that can be hot-swapped.



Warning The covers are an integral part of the safety design of the product. Do not operate the unit without the covers installed.



Warning To reduce risk of electric shock, when installing or replacing the unit, the ground connection must always be made first and disconnected last.



Warning To reduce risk of electric shock or personal injury, disconnect DC power before removing or replacing components or performing upgrades.



Warning Only trained and qualified personnel should be allowed to install, replace, or service this equipment.

Removing AC Power Supplies

Procedure

Step 1 Ensure that the chassis power switch is in the Standby position.

Note It is not required to place the chassis power switch in the Standby position if you want to hot-swap a single power supply.

Step 2 Unplug the power cable from the power supply.

Step 3 Press the retaining latch towards the pull handle, grasp the handle with one hand, and pull the power supply out of the slot while supporting the weight of the power supply with the other hand.

Figure 23: Power Supply Removed from Cisco ASR 1009-X Router

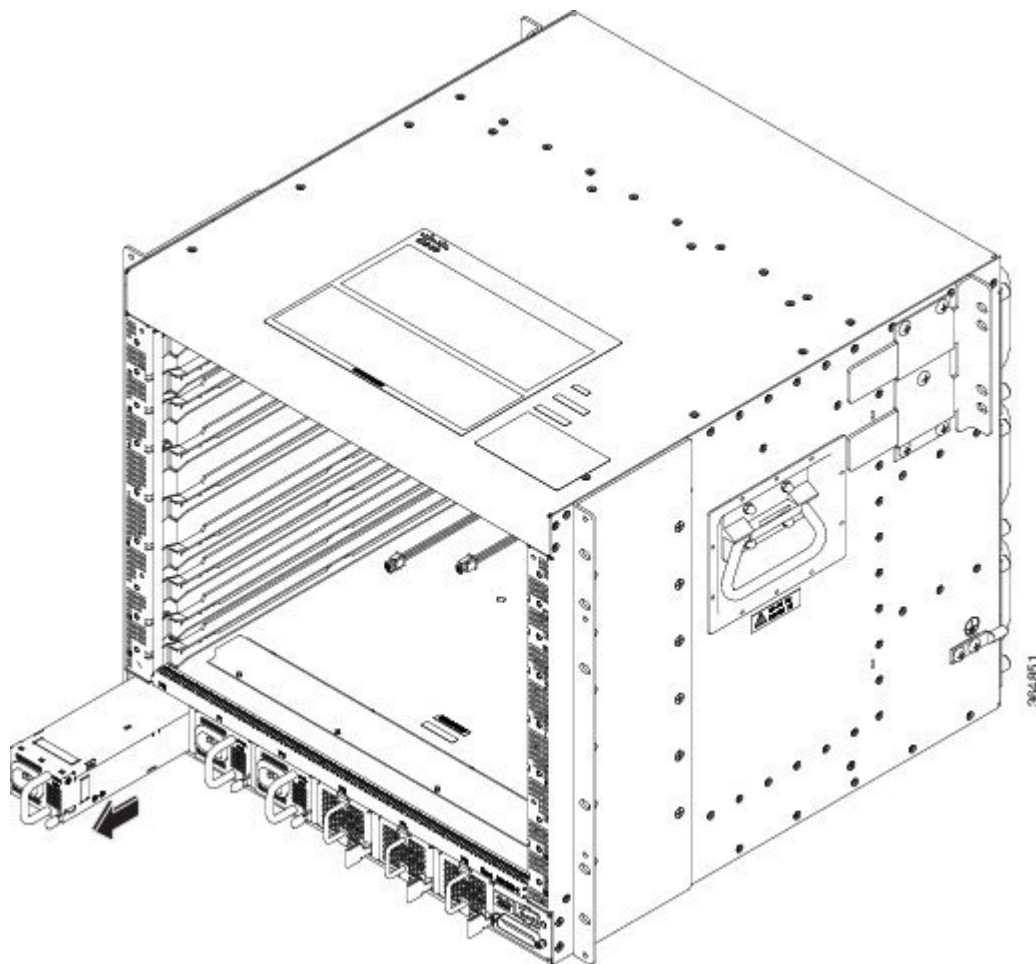

Step 4 Repeat these steps if it is required to remove the other AC power supply.

Installing AC Power Supplies



Note Do not install the power supplies with the chassis cover off.

Procedure

- Step 1** Ensure that the chassis power switch on the chassis is in the Standby position.
- Note** It is not required to place the chassis power switch in the Standby position if you want to hot-swap a single power supply.
- Step 2** Insert the power supply module into the appropriate slot(s), making sure that the retention latch is firmly placed. You can verify that the power supply module is firmly latched by gently pulling the power supply handle.
- Step 3** Insert the power supply cables firmly into the power supplies.
- Note** Ensure that both power supplies are inserted firmly and the power cords are in place.
- Step 4** If you have changed the chassis power switch to the Standby position in Step 1, press the power switch to the On position.
- The power supply LEDs are illuminated (green).
-

Removing DC Input Power Supplies

The DC power supply has a terminal block that is installed into the power supply terminal block header.

Procedure

- Step 1** Turn off the circuit breaker from the power source.
- Step 2** Ensure that the chassis power switch is in the Standby position.
- Note** It is not required to place the chassis power switch in the Standby position if you want to hot-swap a single power supply.
- Step 3** Remove the plastic cover from the terminal block.
- Step 4** Unscrew the two terminal block screws on the unit and remove the wires from the power supply.
- Step 5** Press the power supply retaining latch towards the pull handle, grasp the handle with one hand, and pull the power supply out of the slot while supporting the weight of the power supply with the other hand.
-

Installing DC Input Power Supplies



Warning To reduce risk of electric shock or personal injury, disconnect DC power before removing or replacing components or performing upgrades.



Warning Only trained and qualified personnel should be allowed to install, replace, or service this equipment.



Note Do not install the power supplies with the chassis cover off.

This section describes how to install the DC power supply input power leads to the DC input power supply. Before you begin, read these important notices:

- The color coding of the DC input power supply leads depends on the color coding of the DC power source at your site. Ensure that the lead color coding you choose for the DC input power supply matches the lead color coding used at the DC power source and verify that the power source is connected to the negative (–) terminal and to the positive (+) terminal on the power supply.
- Ensure that the chassis ground is connected on the chassis before you begin installing the DC power supply. Follow the steps provided in the "Attaching the Chassis Ground Connection" section.
- For DC input power cables, the wire gauge is based on the National Electrical Code (NEC) and local codes for 26 amp service at nominal DC input voltage (–40/–72 VDC). One pair of cable leads, source DC (–) and source DC return (+), are required for each power distribution unit (PDU). These cables are available from any commercial cable vendor. All DC input power cables for the chassis should be 10 gauge wire and cable lengths should match within 10 percent of deviation.

Each DC input power cable is terminated at the PDU by a cable lug, as shown in the following figure.



Note DC input power cables must be connected to the PDU terminal studs in the proper positive (+) and negative (–) polarity. In some cases, the DC cable leads are labeled, which is a relatively safe indication of the polarity. However, you must verify the polarity by measuring the voltage between the DC cable leads. When making the measurement, the positive (+) lead and the negative (–) lead must always match the (+) and (–) labels on the power distribution unit.

Figure 24: DC Input Power Cable Lug

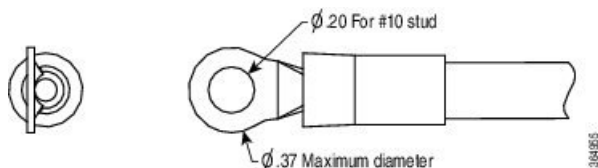



Note To avoid hazardous conditions, all components in the area where DC input power is accessible must be properly insulated. Therefore, before installing the DC cable lugs, be sure to insulate the lugs according to the manufacturer's instructions.

Wiring the DC Input Power Source



Warning To reduce risk of electric shock, when installing or replacing the unit, the ground connection must always be made first and disconnected last.

Procedure

- Step 1** Turn off the circuit breaker from the power source.
- Step 2** Ensure that the chassis power switch is in the Standby position.
- Note** It is not required to place the power switch in the Standby position if you want to hot-swap a single power supply.
- Step 3** Remove the plastic cover from the terminal block.
- Caution** Before you continue to install the terminal block ground wires, stop and perform Step 4.
- Step 4** To prevent any contact with metal lead on the ground wire and the plastic cover, you must wrap the positive and negative lead cables with sleeving. Insulate the lug with shrink sleeving for each lead wire if using non-insulated crimp terminals. Sleeving is not required for insulated terminals.

Figure 25: DC Power Supply Terminal Block Ground Cable Lugs

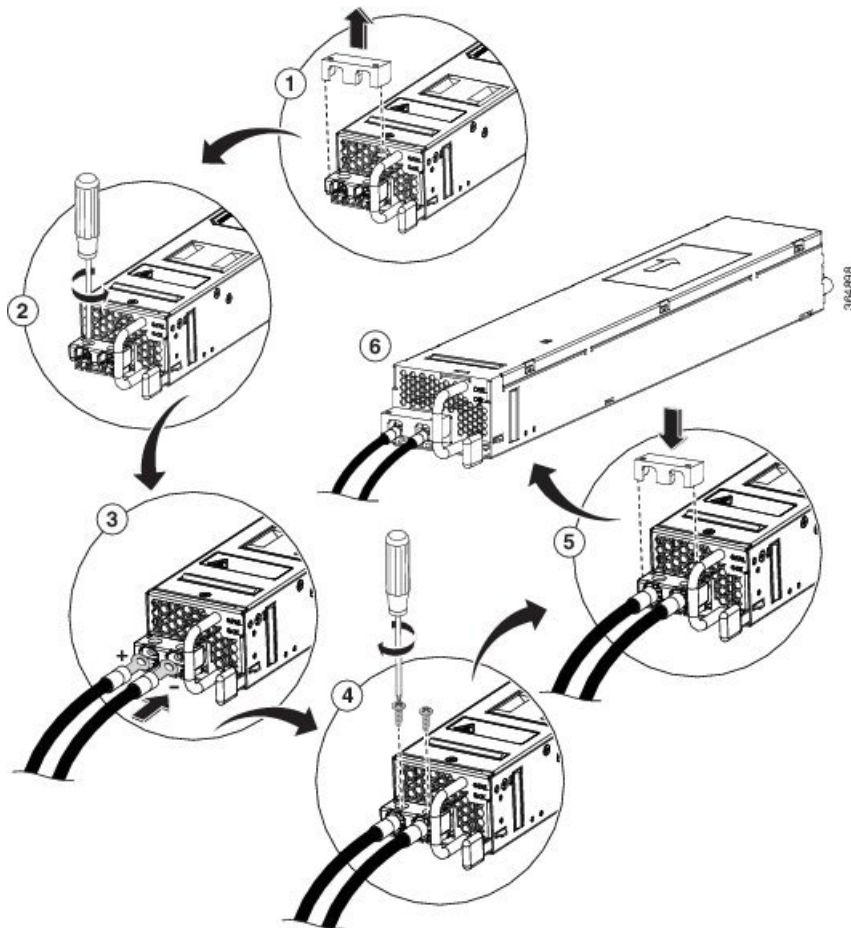

Step 5 For easier cable-management, insert the negative lead cable first. Replace the ground lug with cable in the following order:

- a) Wire terminal
- b) Screw with captive washer

Step 6 Tighten the M5 Screw with captive washer to recommended torque of 5 in-lbs for the positive stud and wire.

Note Secure the wires coming in from the terminal block so that they cannot be disturbed by casual contact.

Step 7 Replace the terminal block plastic cover. The plastic cover is slotted and keyed to fit correctly over the terminal block.

Step 8 Turn on the circuit breaker at the power source.

Step 9 If you have changed the chassis power switch to the Standby position in step 2, turn the power switch to the On position.

The power supply LEDs illuminate green.

Removing and Replacing Fans



Caution Do not replace more than one fan tray at a time while the system is operating.



Caution Replace the fan trays within five minutes to prevent the system from shutting down.

Before you begin

Perform the following steps before you begin the process of removing the fans from a Cisco ASR 1009-X Router or Cisco ASR 1006-X Router:

- Use an ESD-preventive wrist strap.
- Back up the data that you want to save.

Procedure

- Step 1** Position the chassis so that you have the most comfortable access to the chassis to remove the fans. The fans are located at the rear of the chassis.
- Step 2** With an ESD wrist strap on, loosen the four screws that secure the fan tray to the chassis, and then slide the fan tray out of the chassis using the two handles.

Figure 26: Fan Tray Removed from the ASR 1006-X Router

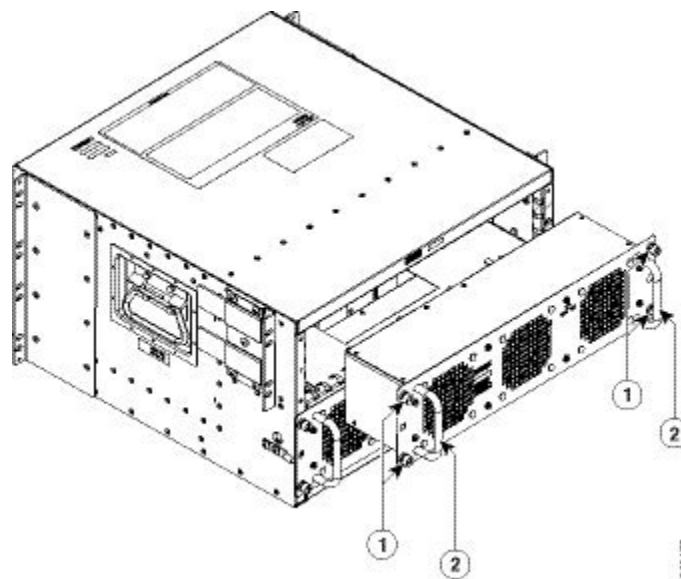

- Step 3** Align the fan tray within the chassis opening, and then carefully insert it until it is fully inserted into the chassis.
- Step 4** Tighten the four mounting screws to a torque of seven inch-lbs. (0.8 N-m).
-