



Hewlett Packard
Enterprise

HPE StoreEasy 1x60 Storage Getting Started Guide

Abstract

This document contains setup, installation, and configuration information for the HPE StoreEasy 1x60 Storage systems.

Part Number: P04179-021
Published: March 2018
Edition: 1

Notices

The information contained herein is subject to change without notice. The only warranties for Hewlett Packard Enterprise products and services are set forth in the express warranty statements accompanying such products and services. Nothing herein should be construed as constituting an additional warranty. Hewlett Packard Enterprise shall not be liable for technical or editorial errors or omissions contained herein.

Confidential computer software. Valid license from Hewlett Packard Enterprise required for possession, use, or copying. Consistent with FAR 12.211 and 12.212, Commercial Computer Software, Computer Software Documentation, and Technical Data for Commercial Items are licensed to the U.S. Government under vendor's standard commercial license.

Links to third-party websites take you outside the Hewlett Packard Enterprise website. Hewlett Packard Enterprise has no control over and is not responsible for information outside the Hewlett Packard Enterprise website.

Acknowledgments

Microsoft® and Windows® are either registered trademarks or trademarks of Microsoft Corporation in the United States and/or other countries.

Contents

- Introduction to HPE StoreEasy 1000 System..... 4**

- Setup and install..... 5**
 - 1. Unpack HPE StoreEasy 1X60 Storage.....5
 - 2. Installing the rail kits and mounting the system in a rack.....8
 - 3. Cabling the StoreEasy system to the network.....11
 - 4. Power Up.....11
 - 5. Power On Initial Startup Sequence.....12

- Specifications and requirements.....16**

- Websites..... 21**

- Support and other resources.....22**
 - Accessing Hewlett Packard Enterprise Support..... 22
 - Accessing updates.....22
 - Customer self repair.....23
 - Remote support..... 23
 - Warranty information.....23
 - Regulatory information.....24
 - Documentation feedback..... 24

Introduction to HPE StoreEasy 1000 System

HPE StoreEasy 1000 network-attached storage (NAS) appliances are purpose-built for storing file and application data. Tailored for small to mid-size organizations, branch offices, and workgroup environments, HPE StoreEasy 1000 storage delivers rich file data services and simplified management through a foundation of Microsoft Windows Storage Server and Hewlett Packard Enterprise technologies. To help the organizations significantly reduce the time and the complexity of the installation, each HPE StoreEasy 1000 storage appliance is shipped with pre-integrated hardware and preloaded software.

Hewlett Packard Enterprise has multiple solutions that enhance the ability to manage and monitor StoreEasy systems. By default, the HPE Systems Insight Manager and Integrate Lights Out (iLO) along with the HPE StoreEasy management console are available for use on all HPE StoreEasy 1X60 systems.

HPE StoreEasy 1X60 systems have several Microsoft management options pre-configured which include the Microsoft Server Manager, File and Storage Services, IIS and Print Services.

Built on the HPE ProLiant foundation, HPE StoreEasy 1000 systems leverage the following platforms:

StoreEasy Model	Platform
HPE StoreEasy 1660 Storage	HPE ProLiant DL380 Gen10 server (LFF)
HPE StoreEasy 1860 Storage	HPE ProLiant DL380 Gen10 server (SFF)

Setup and install

1. Unpack HPE StoreEasy 1X60 Storage

Before you begin, ensure that you have the following items in the shipping box:

- **Hardware Components**

- HPE StoreEasy 1X60 Storage system
- Power cords
- Rail kit for installing the system in a rack
- Any other hardware options purchased

- **Documentation and Media**

- HPE StoreEasy 1X60 Read This First document
- HPE StoreEasy 1X60 Storage Quick Start Guide
- Windows Storage Server 2016 (WSS2016) Certificate of Authenticity (COA) label (affixed to the product)
- An envelope containing HPE Integrated Lights-Out (iLO) Advanced Security Edition license key and document
- HPE StoreEasy 1X60 System Recovery DVD (if purchased)

If any of the above-mentioned items are missing, contact Hewlett Packard Enterprise

(<https://www.hpe.com/us/en/contact-hpe.html>) for assistance.

ⓘ IMPORTANT:

For support purposes, you must know how to locate or have a copy of the StoreEasy 1X60 Storage system serial number, the Product ID key from WSS2016 COA, and the iLO Advanced Security license key.

To verify the HPE StoreEasy model and warranty information, HPE personnel uses the serial number of the system located in the following places:

Description	Image
<p>On a label affixed outside the HPE StoreEasy 1X60 Storage shipping box</p>	
<p>Top of the HPE StoreEasy 1X60 Storage chassis</p>	
<p>Inside of the HPE StoreEasy 1X60 Storage chassis</p>	

Table Continued

Description	Image
Pull out serial number tab which is inside the enclosure	
	

The Windows Storage Server COA label Product ID key is required when:

- You have replaced the motherboard of StoreEasy 1X60 product.
- You have upgraded the original version of the Windows Storage Server operating system to a "new" release, then the new COA product ID key is required to activate the operating system.
- The system fails to activate properly due to the corruption in the key.

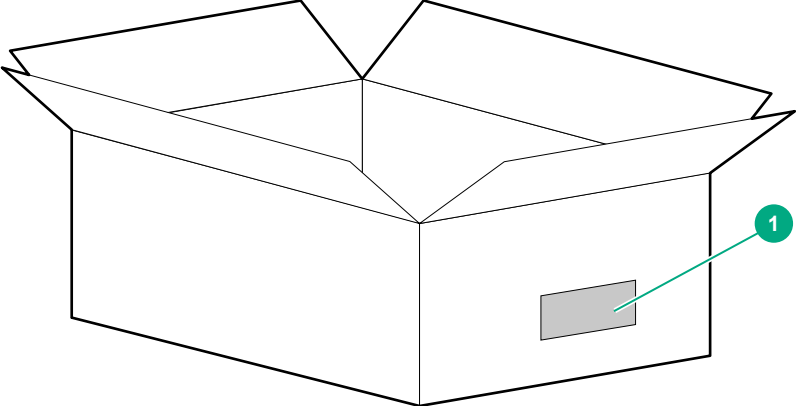
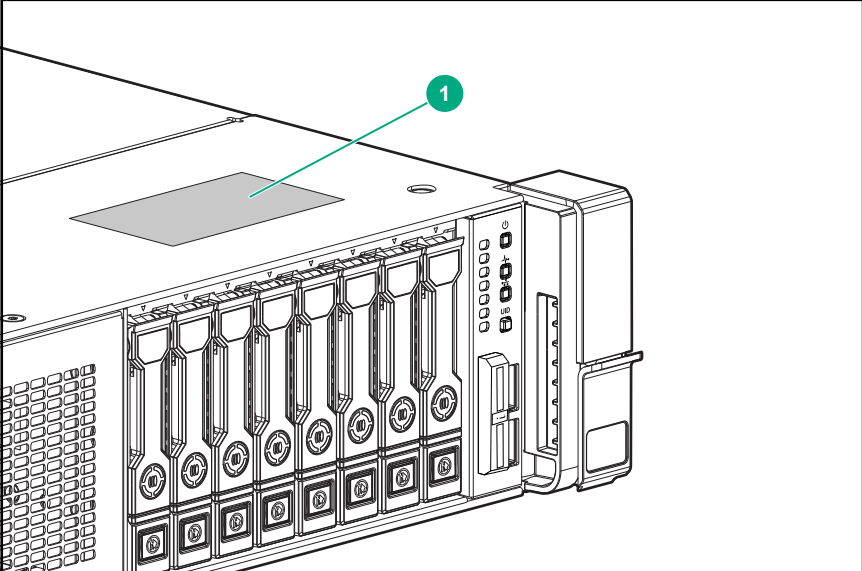
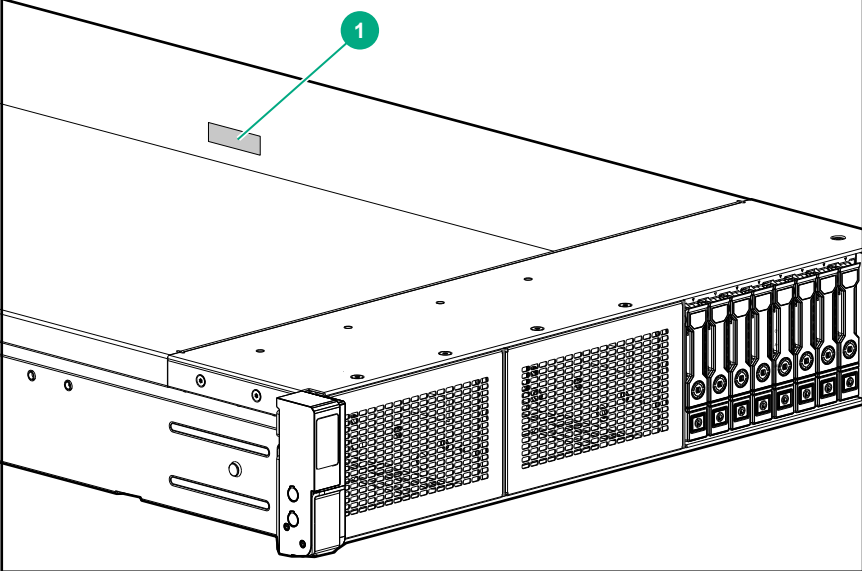
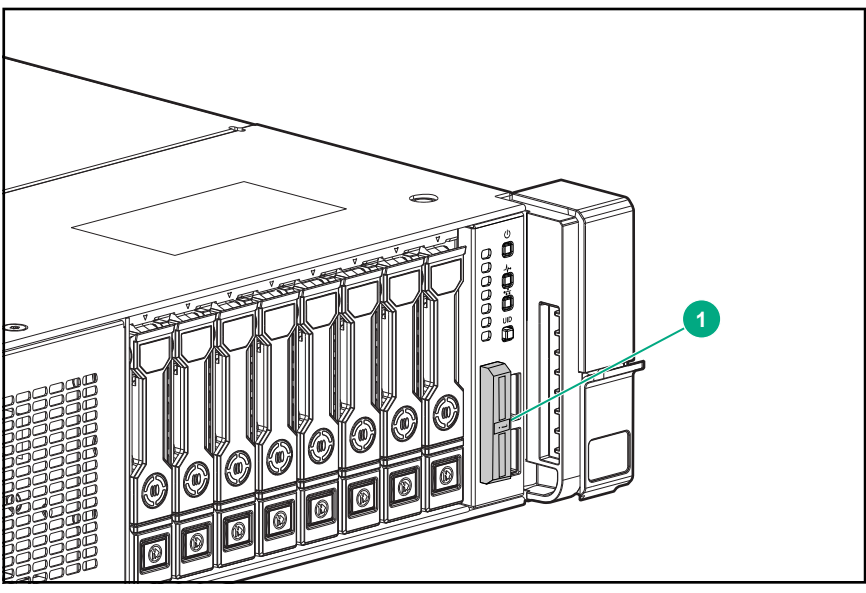
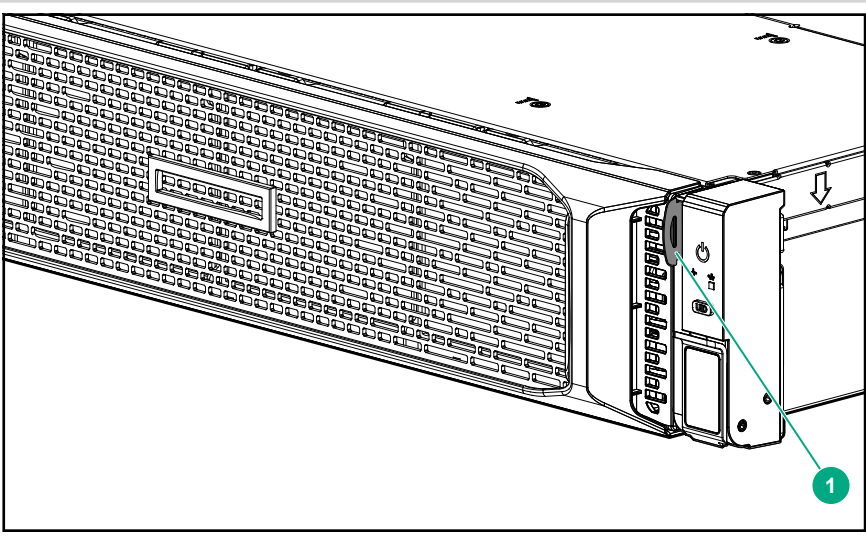
The iLO Advanced Security license key is required when:

- The motherboard of StoreEasy 1X60 product is replaced.
- The iLO license key must be reinstalled.

2. Installing the rail kits and mounting the system in a rack

Important safety information

CAUTION:

Electrostatic Discharge (ESD) can damage the electronic components. Ensure that you are properly grounded (earthed) before beginning any installation procedure.

Installation Guidelines

This installation must be performed by qualified individuals having knowledge of the procedures, precautions, and equipment hazards that contains hazardous electrical circuits.

WARNING:

- The rail kits, when installed, form only a shelf for the StoreEasy 1X60 to rest on. The StoreEasy 1X60 is not attached to the rail by any other means. Use extreme caution when pulling the StoreEasy 1X60 out from the rack. The storage system can slip and fall, which may cause damage or injury to the StoreEasy 1X60 Storage. HPE is not responsible for any damage or injury caused by mishandling of StoreEasy 1X60.
 - Ensure that the rack is leveled and stable before working on the rack. The leveling jacks (feet) must extend to the floor and the full weight of the rack must rest firmly on the floor.
 - Ensure that the rack has anti-tip measures such as, floor-bolting, anti-tip feet, ballast, or a combination of the measures, as specified by the rack manufacturer and applicable codes in place.
 - Ensure that sufficient personnel are available to support one or more products during the installation process. HPE recommends you to use an appropriate lifting device as an installation aid.
 - Ensure that the rack is loaded from bottom to top, with the heaviest appliances at the bottom to make the rack steady.
 - Avoid overloading the branch circuit that provides power to the rack. The total rack load must not exceed 80 percent of the branch circuit rating.
-

Installation

1. Install the rail kits.

For detailed instructions on installing the HPE rack rails into square and round hole racks for HPE 2U Storage system, refer *HPE Rack Rail Kit installation instructions* document, that is part of the shipped rail kit.

2. Slide the StoreEasy 1X60 into the position on the rails as shown in Figure 1.

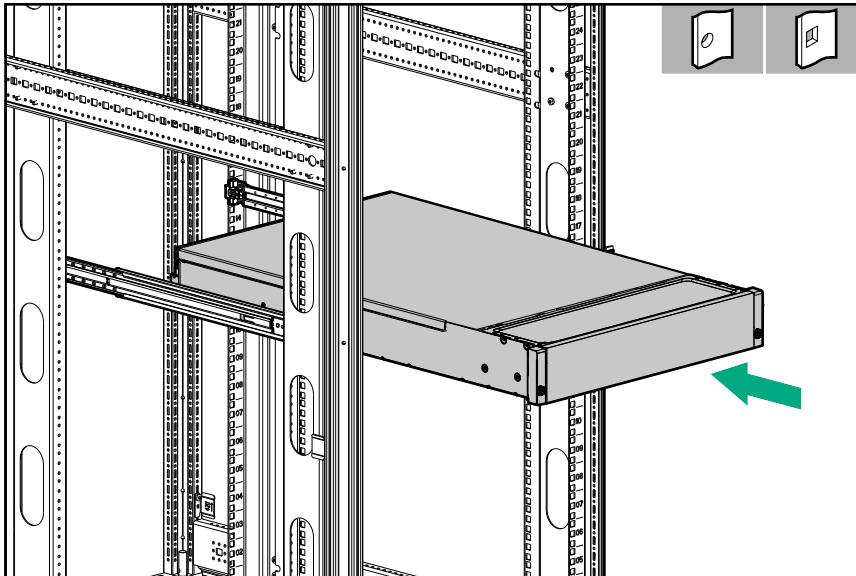

Figure 1: StoreEasy 1X60 insertion into the rack

3. To secure the StoreEasy 1X60 to the rails, the Configure-to-Order (CTO) bracket at the rear ends of the rails must overlap the chassis tab as shown in Figure 2.

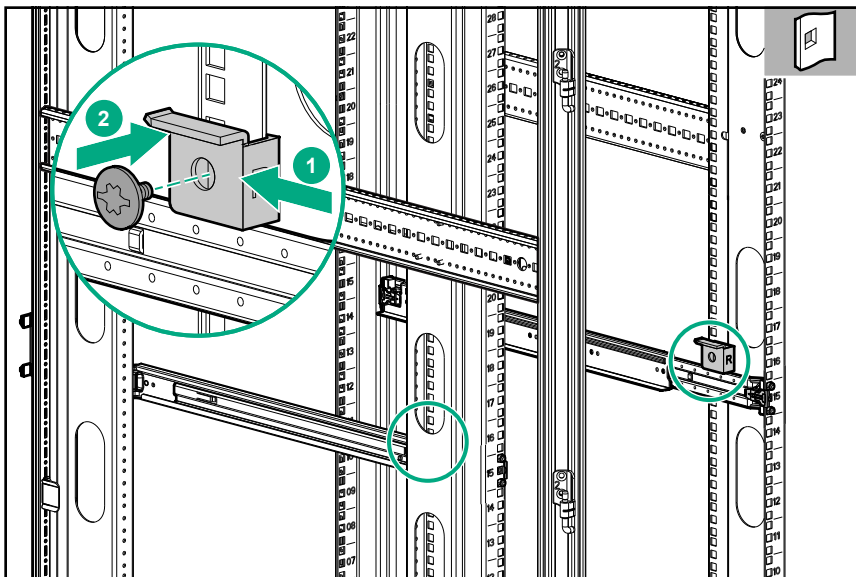

Figure 2: CTO bracket location

- Secure the StoreEasy 1X60 to the rack rails using thumbscrews on the front bezel as shown in Figure 3.

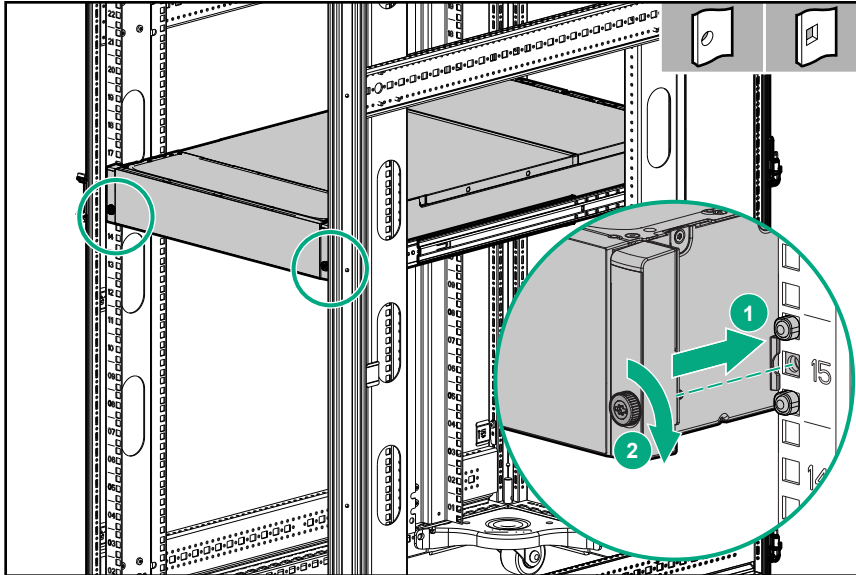

Figure 3: Secure StoreEasy 1X60 to the rack

- Using the holes provided in the rear rack rails, install the tie wraps and route external cables as required as shown in Figure 4.

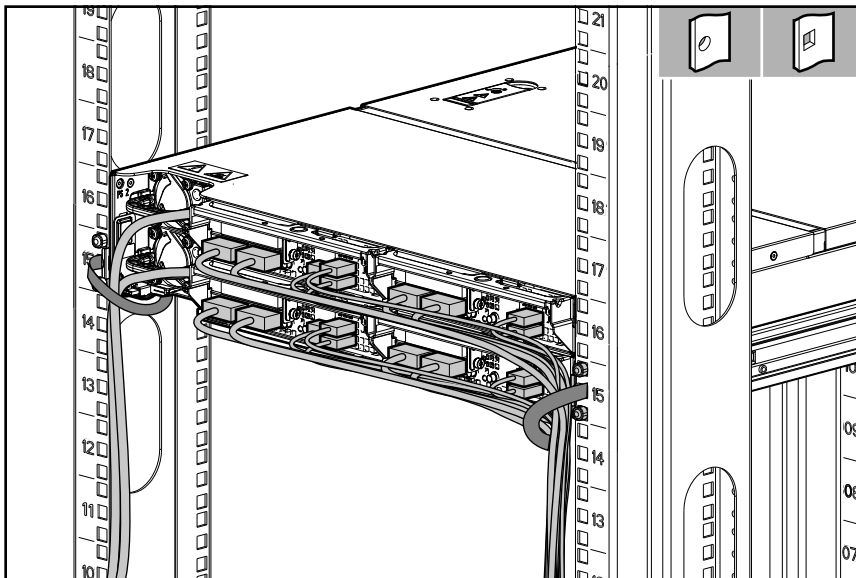

Figure 4: Cable management with tie wraps

- Connect all power cords to the facility power source.

3. Cabling the StoreEasy system to the network

The iLO network port is used to remotely manage the StoreEasy 1X60 hardware and allows administrators to launch a remote console session to the system. HPE recommends that you connect the iLO port to your management network. The iLO port is preconfigured to obtain an IP address through DHCP. If your environment does not support DHCP, use a KVM and configure iLO to use a static IP address. For instructions, see *HPE StoreEasy 1X60 Storage System Administrator Guide* available at <https://support.hpe.com/hpsc/public/home/documentHome?sp4ts.oid=1008632547>.

The 4 x 1GbE network ports are used for the storage network and to connect the system to infrastructure services such as, Active Directory, DNS, NTP, and so on. The ports can be configured as segregated network ports or a network team. Ensure that your switch is prepared for either configuration.

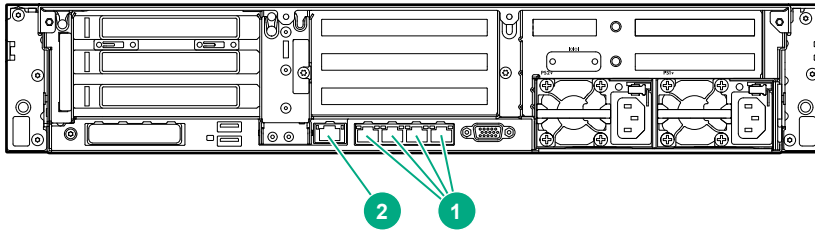

Figure 5: Rear view of the StoreEasy 1660 and StoreEasy 1860 Storage system

Where,

1. Network Ports
2. iLO Port

If you have purchased additional interface cards for your StoreEasy 1X60, the following table guides you on where to install them. The numerical values indicate the order of installation.

Description	PCIe Slot 1 (x8)	PCIe Slot 2 (x16)	PCIe Slot 3 (x8)	FlexLO M Slot	PCIe Slot 4 (x8) ¹	PCIe Slot 5 (x16) ¹	PCIe Slot 6 (x8) ¹
	Primary Riser				Secondary Riser ¹		
HPE M.2 Kit with 2 x M.2 SSDs	Slot Not Available	Slot Not Available	X	Slot Not Available	Slot Not Available	Slot Not Available	Slot Not Available
FlexLOM			Slot Not Available	1			
PCIe x16 ²		1		Slot Not Available		1	
PCIe x8 or less	1	2			1	2	3

¹ Slots for Secondary Riser require that the second processor is installed before they are available for use. PCIe Slot 4 and PCIe Slot 5 are not available when using the riser with the 2 x SFF cage.

² PCIe x16 on Primary Riser is only available on the StoreEasy 1660 system. The StoreEasy 1860 system uses this slot for the SAS expander card.

4. Power Up

Power up the storage system using power button on the front panel as shown in Figure 6.

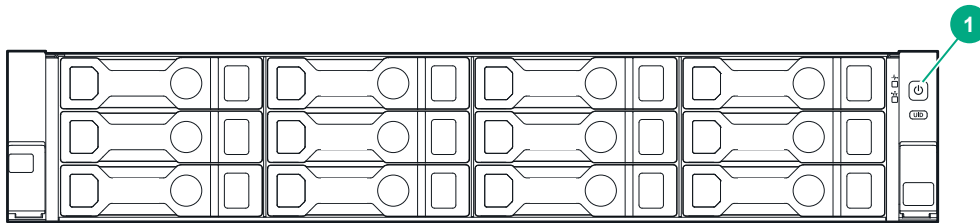

Figure 6: HPE StoreEasy 1X60 Storage

1 - Power button



IMPORTANT:

If you are connecting a disk enclosure to HPE StoreEasy 1X60 at the time of installation, power on the external storage system before you power on the HPE StoreEasy 1X60 Storage system.

5. Power On Initial Startup Sequence

You can complete the initial startup sequence by connecting to the StoreEasy 1X60 using a KVM to configure a static IP or to gather the DHCP address from the boot screen.

Alternatively, you can complete the initial startup sequence by connecting to the StoreEasy 1X60 using iLO Integrated Remote Console (IRC) remotely. If the iLO port is connected to a network segment with DHCP enabled and automatic DNS registration, use the DNS name. The DNS name, iLO initial login, and iLO initial password are available on the information tag attached to the front of the system on the right-hand side.

For more information on DHCP configuration and DNS registration, see *HPE StoreEasy 1X60 Storage System Administrator Guide* available at

<https://support.hpe.com/hpesc/public/home/documentHome?sp4ts.oid=1008632547>.

Once StoreEasy 1X60 is booted, the language selection screen is displayed.

Hi there

Let's get a few basic things out of the way.

Deutsch

English

español

français

italiano

русский

中文(简体)

日本語



Next

NOTE:

If the language selection screen does not display, contact Hewlett Packard Enterprise support center (<https://www.hpe.com/us/en/contact-hpe.html>).

Follow the instructions of the on-screen wizard:

1. Select your preferred language.
2. Read and accept the license terms.
3. Set the local Administrator password.

Once these steps are complete, log in as Administrator. A post-installation process automatically starts and takes approximately 10-15 minutes. The system reboots at the end of the post installation.

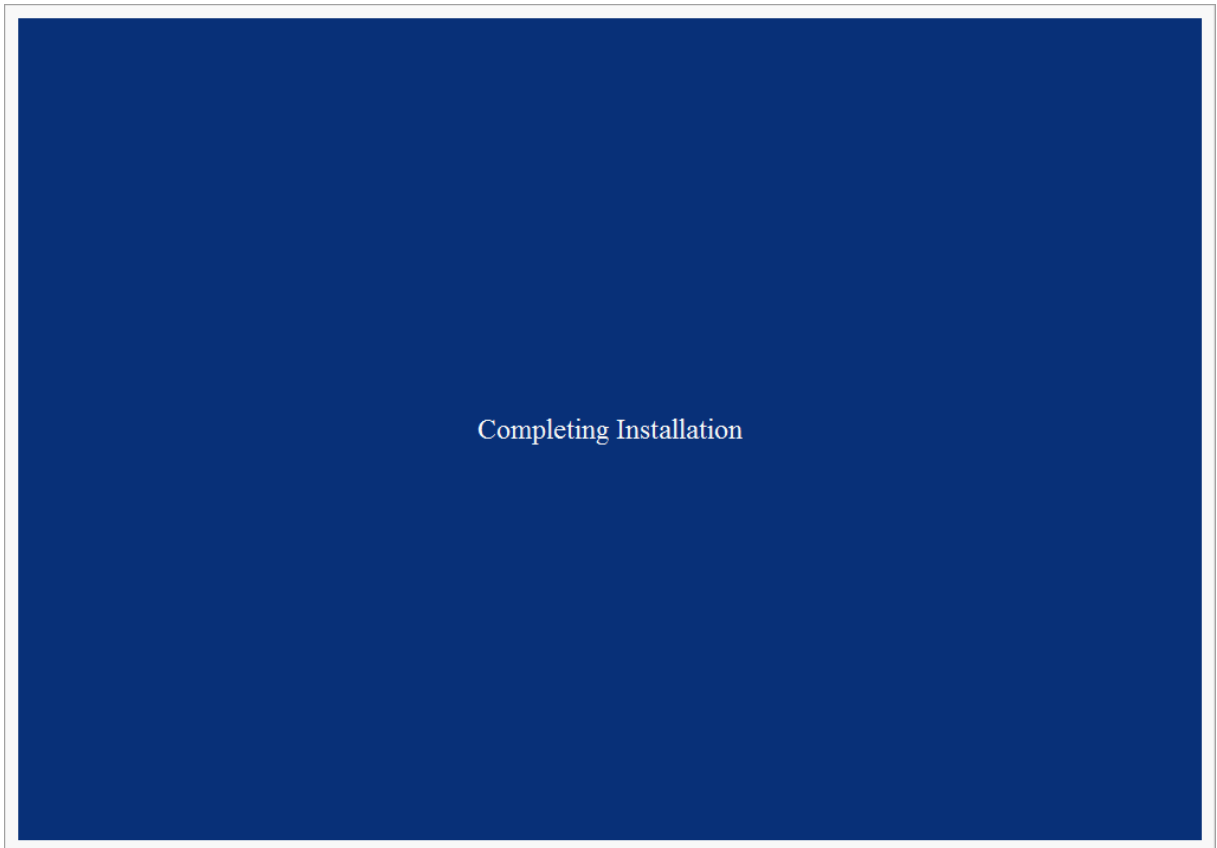

4. After the reboot, log in with the Administrator account and password set in Step 3.
The system launches the Initial Configuration Tasks (ICT) application.

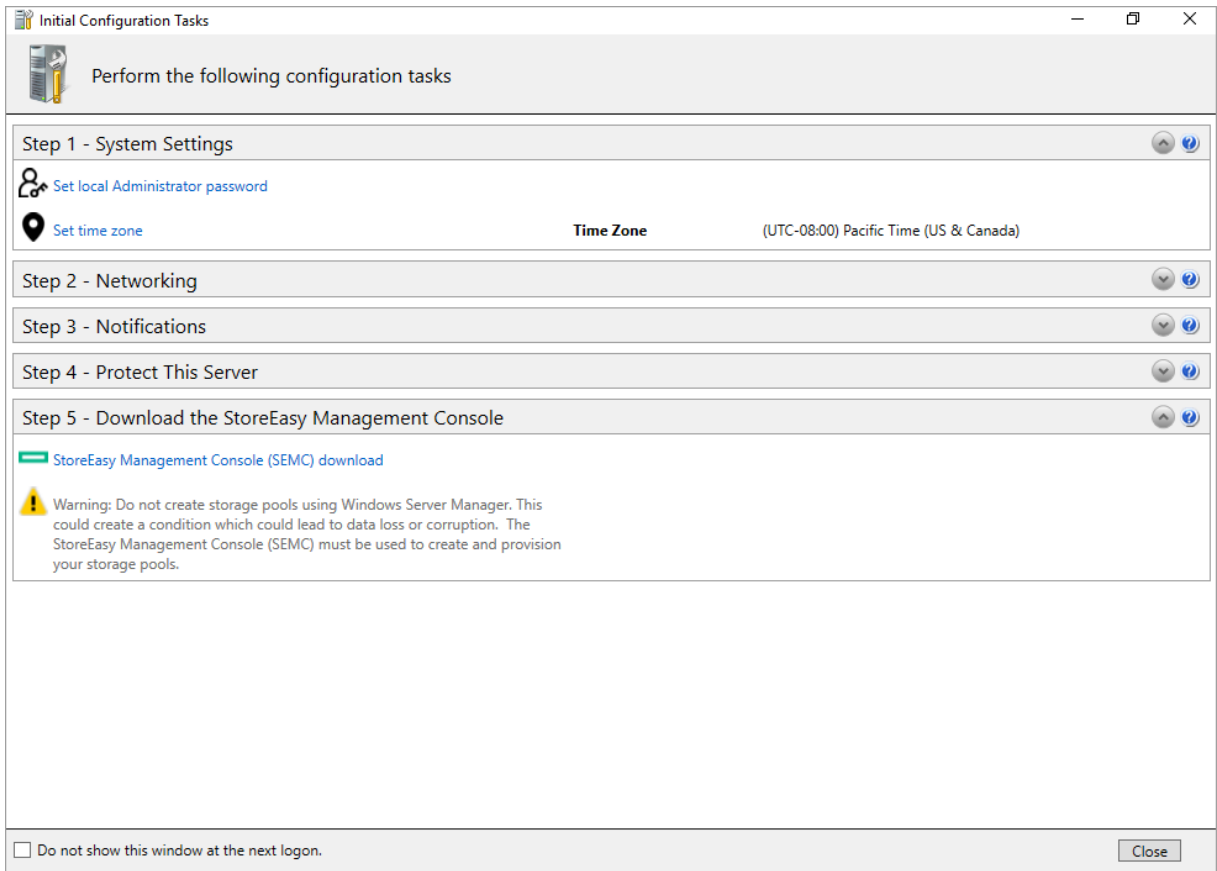

Figure 7: Initial Configuration Tasks

If ICT does not launch automatically, press **Windows + R**(run) on your keyboard, type `C:\Windows\System32\oemooobe\OemOobe.exe` and click **OK**.

Specifications and requirements

Table 1: StoreEasy 1660 and 1860 Storage

Dimension (H x W x D)	HPE StoreEasy 1860		3.44 x 17.54 x 26.75 in (8.73 x 44.55 x 67.94 cm)
NOTE: Dimensions without Bezel.	HPE StoreEasy 1660		3.44 x 17.54 x 28.75 in (8.73 x 44.55 x 73.02 cm)
Weight (approximate)	HPE StoreEasy 1660	Maximum (Maximum - 12 LFF hard drives (no rear drives), 2x processors, 2x power supplies, 1x Smart Array, 2x Risers installed)	54 lbs (24.5 kg)
	HPE StoreEasy 1860	Minimum (Minimum - 8SFF chassis with 1xSFF HDD and 7 HDD blanks, 1x processor, 1x power supply (plus blank), 1x Flexible Smart Array, 1x Riser installed) 2x Drive Bay blanks, 1x processor including standard heatsink, 1x power supply (plus blank), 1x Smart Array, 1x Riser Minimum: 14.9 kg installed, cables for the above).	32.75 lbs (14.9 kg)
Input Requirements (per power supply)	Rated Line Voltage		100 to 120 VAC, 200 to 240 VAC
BTU Rating	Maximum		For 800W Power Supply: 3207 BTU/hr (at 100 VAC), 3071 BTU/hr (at 200 VAC), 3112 BTU/hr (at 240 VAC) input for China only For 500W Power Supply: 1979 BTU/hr (at 100 VAC), 1911 BTU/hr (at 240 VAC), 1965 BTU/hr (at 240 VAC) input for China only

Table Continued

Power Supply Output (per power supply)	Rated Steady-State Power	<p>For 1400W Power Supply: 1400W (at 240 VAC), 1400W (at 240 VAC)</p> <p>For 800W Power Supply: 800W (at 100 VAC), 800W (at 240 VAC), 800W (at 240 VAC) input for China only</p> <p>For 500W Power Supply: 500W (at 100 VAC), 500W (at 240 VAC), 500W (at 240 VAC) input for China only</p>
	Maximum Peak Power	<p>For 1400W Power Supply: 1400W (at 200 to 240 1VAC), 1400W (at 240 VAC) input for China only</p> <p>For 800W Power Supply: 800W (at 100 to 127 VAC), 800W (at 200 to 240 1VAC), 800W (at 240 VAC) input for China only</p> <p>For 500W Power Supply: 500W (at 100 to 127 VAC), 500W (at 200 to 240 VAC), 500W (at 240 VAC) input for China only</p>
System Inlet Temperature	Standard Operating Temperature	<p>10° to 35°C (50° to 95°F) at sea level with an altitude derating of 1.0°C per every 305 m (1.8°F per every 1000 ft) above sea level to a maximum of 3050 m (10,000 ft), no direct sustained sunlight.</p> <p>Maximum rate of change is 20°C/hr (36°F/hr). The upper limit and rate of change may be limited by the type and number of options installed.</p> <p>System performance during standard operating support may be reduced if operating with a fan fault or above 30°C (86°F).</p>

Table Continued

	Extended Ambient Operating Temperature	<p>For approved hardware configurations, the supported system inlet range is extended to be: 5° to 10°C (41° to 50°F) and 35° to 40°C (95° to 104°F) at sea level with an altitude derating of 1.0°C per every 175 m (1.8°F per every 574 ft) above 900 m (2953 ft) to a maximum of 3050 m (10,000 ft). The approved hardware configurations for this system are listed at the URL: http://www.hpe.com/servers/ashrae.</p> <p>For approved hardware configurations, the supported system inlet range is extended to be: 40° to 45°C (104° to 113°F) at sea level with an altitude derating of 1.0°C per every 125 m (1.8°F per every 410 ft) above 900 m (2953 ft) to a maximum of 3050 m (10,000 ft). The approved hardware configurations for this system are listed at the URL: http://www.hpe.com/servers/ashrae.</p> <p>System performance may be reduced if operating in the extended ambient operating range or with a fan fault.</p>
	Non-operating	-30° to 60°C (-22° to 140°F). Maximum rate of change is 20°C/hr (36°F/hr).
Relative Humidity (non-condensing)	Operating	8% to 90% - Relative humidity (Rh), 28°C maximum wet bulb temperature, non-condensing.
	Non-operating	5 to 95% relative humidity (Rh), 38.7°C (101.7°F) maximum wet bulb temperature, non-condensing.
Altitude	Operating	3050 m (10,000 ft). This value may be limited by the type and number of options installed. Maximum allowable altitude change rate is 457 m/min (1500 ft/min).
	Non-operating	9144 m (30,000 ft). Maximum allowable altitude change rate is 457 m/min (1500 ft/min).

Table Continued

Acoustic Noise	<p>Listed are the declared A-Weighted sound power levels (L_{WAd}) and declared average bystander position A-Weighted sound pressure levels (L_{pAm}) when the product is operating in a 23°C ambient environment. Noise emissions were measured in accordance with ISO 7779 (ECMA 74) and declared in accordance with ISO 9296 (ECMA 109). The listed sound levels apply to standard shipping configurations. Additional options may result in increased sound levels. Please have your HPE representative provide information from the HPE EMESC website for further technical details regarding the configurations listed below.</p>
Idle	
LWAd	4.8 B Entry
	4.4 B Base
	4.6 B Perf
LpAm	37 dBA Entry
	31 dBA Base
	31 dBA Perf
Operating	
LWAd	4.8 B Entry
	4.4 B Base
	4.6 B Perf
LpAm	37 dBA Entry
	31 dBA Base
	31 dBA Perf
NOTE:	
<ul style="list-style-type: none"> • Acoustics levels presented here are generated by the test configuration only. Acoustics levels will vary depending on system configuration. Values are subject to change without notification and are for reference only. • Product conformance to cited product specifications is based on sample (type) testing, evaluation, or assessment. This product or family of products is eligible to bear the appropriate compliance logos and statements. • The Listed sound levels apply to standard shipping configurations. Additional options may result in increased sound levels. 	

Table Continued

Emissions Classification (EMC) – Regulatory Information	To view the regulatory information for your product, view the Safety and Compliance Information for Server, Storage, Power, Networking, and Rack Products, available at the Hewlett Packard Enterprise Support Center: http://www.hpe.com/support/Safety-Compliance-EnterpriseProducts	
Environment friendly Products and Approach	End-of-life Management and Recycling	<p>Hewlett Packard Enterprise offers end-of-life product return, trade-in, and recycling programs, in many geographic areas, for our products. Products returned to Hewlett Packard Enterprise will be recycled, recovered or disposed of in a responsible manner.</p> <p>The EU WEEE directive (2002/95/EC) requires manufacturers to provide treatment information for each product type for use by treatment facilities. This information (product disassembly instructions) is posted on the Hewlett Packard Enterprise web site. These instructions may be used by recyclers and other WEEE treatment facilities as well as Hewlett Packard Enterprise OEM customers who integrate and re-sell Hewlett Packard Enterprise equipment.</p>

Other specifications for the individual components are located in the User Guide for each product:

StoreEasy model	Document	Location
StoreEasy 1660 Storage	HPE ProLiant DL380 Gen 10 Server User Guide	https://internal.support.hpe.com/hpsc/doc/public/display?sp4ts.oid=1010657641&docLocale=en_US&docId=emr_na-a00019109en_us
StoreEasy 1860 Storage	HPE ProLiant DL380 Gen 10 Server User Guide	https://internal.support.hpe.com/hpsc/doc/public/display?sp4ts.oid=1010657641&docLocale=en_US&docId=emr_na-a00019109en_us

Websites

General websites

Hewlett Packard Enterprise Information Library

www.hpe.com/info/EIL

Single Point of Connectivity Knowledge (SPOCK) Storage compatibility matrix

www.hpe.com/storage/spock

Storage white papers and analyst reports

www.hpe.com/storage/whitepapers

For additional websites, see **[Support and other resources](#)**.

Support and other resources

Accessing Hewlett Packard Enterprise Support

- For live assistance, go to the Contact Hewlett Packard Enterprise Worldwide website:
<http://www.hpe.com/assistance>
- To access documentation and support services, go to the Hewlett Packard Enterprise Support Center website:
<http://www.hpe.com/support/hpesc>

Information to collect

- Technical support registration number (if applicable)
- Product name, model or version, and serial number
- Operating system name and version
- Firmware version
- Error messages
- Product-specific reports and logs
- Add-on products or components
- Third-party products or components

Accessing updates

- Some software products provide a mechanism for accessing software updates through the product interface. Review your product documentation to identify the recommended software update method.
- To download product updates:

Hewlett Packard Enterprise Support Center

www.hpe.com/support/hpesc

Hewlett Packard Enterprise Support Center: Software downloads

www.hpe.com/support/downloads

Software Depot

www.hpe.com/support/softwaredepot

- To subscribe to eNewsletters and alerts:
www.hpe.com/support/e-updates
- To view and update your entitlements, and to link your contracts and warranties with your profile, go to the Hewlett Packard Enterprise Support Center **More Information on Access to Support Materials** page:

❗ **IMPORTANT:**

Access to some updates might require product entitlement when accessed through the Hewlett Packard Enterprise Support Center. You must have an HPE Passport set up with relevant entitlements.

Customer self repair

Hewlett Packard Enterprise customer self repair (CSR) programs allow you to repair your product. If a CSR part needs to be replaced, it will be shipped directly to you so that you can install it at your convenience. Some parts do not qualify for CSR. Your Hewlett Packard Enterprise authorized service provider will determine whether a repair can be accomplished by CSR.

For more information about CSR, contact your local service provider or go to the CSR website:

<http://www.hpe.com/support/selfrepair>

Remote support

Remote support is available with supported devices as part of your warranty or contractual support agreement. It provides intelligent event diagnosis, and automatic, secure submission of hardware event notifications to Hewlett Packard Enterprise, which will initiate a fast and accurate resolution based on your product's service level. Hewlett Packard Enterprise strongly recommends that you register your device for remote support.

If your product includes additional remote support details, use search to locate that information.

Remote support and Proactive Care information

HPE Get Connected

www.hpe.com/services/getconnected

HPE Proactive Care services

www.hpe.com/services/proactivecare

HPE Proactive Care service: Supported products list

www.hpe.com/services/proactivecaresupportedproducts

HPE Proactive Care advanced service: Supported products list

www.hpe.com/services/proactivecareadvancedsupportedproducts

Proactive Care customer information

Proactive Care central

www.hpe.com/services/proactivecarecentral

Proactive Care service activation

www.hpe.com/services/proactivecarecentralgetstarted

Warranty information

To view the warranty for your product or to view the *Safety and Compliance Information for Server, Storage, Power, Networking, and Rack Products* reference document, go to the Enterprise Safety and Compliance website:

www.hpe.com/support/Safety-Compliance-EnterpriseProducts

Additional warranty information

HPE ProLiant and x86 Servers and Options

www.hpe.com/support/ProLiantServers-Warranties

HPE Enterprise Servers

www.hpe.com/support/EnterpriseServers-Warranties

HPE Storage Products

www.hpe.com/support/Storage-Warranties

HPE Networking Products

www.hpe.com/support/Networking-Warranties

Regulatory information

To view the regulatory information for your product, view the *Safety and Compliance Information for Server, Storage, Power, Networking, and Rack Products*, available at the Hewlett Packard Enterprise Support Center:

www.hpe.com/support/Safety-Compliance-EnterpriseProducts

Additional regulatory information

Hewlett Packard Enterprise is committed to providing our customers with information about the chemical substances in our products as needed to comply with legal requirements such as REACH (Regulation EC No 1907/2006 of the European Parliament and the Council). A chemical information report for this product can be found at:

www.hpe.com/info/reach

For Hewlett Packard Enterprise product environmental and safety information and compliance data, including RoHS and REACH, see:

www.hpe.com/info/ecodata

For Hewlett Packard Enterprise environmental information, including company programs, product recycling, and energy efficiency, see:

www.hpe.com/info/environment

Documentation feedback

Hewlett Packard Enterprise is committed to providing documentation that meets your needs. To help us improve the documentation, send any errors, suggestions, or comments to Documentation Feedback (docsfeedback@hpe.com). When submitting your feedback, include the document title, part number, edition, and publication date located on the front cover of the document. For online help content, include the product name, product version, help edition, and publication date located on the legal notices page.