

NX-FMS1337

Full Motion Small TV Mount 13-37"/40lb



1. Limited Warranty

a. General

Subject to the terms and conditions of this Limited Warranty, from the date of sale through the period of time for product categories specified in Section 1(a), ADI warrants ADI branded products to be free from defects in materials and workmanship under normal use and service, normal wear and tear excepted. Except as required by law, this Limited Warranty is only made to Buyer and may not be transferred to any third party.

ADI shall have no obligation under this Limited Warranty or otherwise if:

- (i) The product is improperly installed, applied or maintained;
- (ii) The product is installed outside of stated operating parameters, altered, or improperly services or repaired;
- (iii) Damage is caused by outside natural occurrences, such as lightning, power surges, fire, floods, acts of nature, or the like.
- (iv) Defects resulting from unauthorized modification, misuse, vandalism, or other causes unrelated to defective materials or workmanship, or failures related to batteries of any type used in connection with the products sold hereunder.

ADI only warrants those products branded for ADI and sold by ADI. Any other products branded by third parties are warranted by the third party manufacturer for a period as defined by the third party manufacturer, and ADI assigns to Buyer those warranties and only those warranties extended by such third party manufacturers or vendors for non-ADI branded products. ADI does not itself warrant any non-ADI branded product and sells only on an as is basis in accordance with ADI’s terms and conditions of sale.

a. Specific Warranties for product categories are as follows :

Product Categories	Warranty Period
Intrusion Wireless Communication Accessories	12 months
Keystones, Wall plates, Accessories	24 months
CCTV Power Supplies	24 months
In Ceiling Speakers	24 months
Magnetic Locks	24 months
Surge Protection	24 months
UPS (uninterruptible power supplies)	24 months
HDMI Distribution	24 months
6 Outlet Surge Protection	24 Months
Intrusion Audio Devices	30 months
Video Surveillance Monitors	30 months
Power and Relays	30 months
Hold-up Buttons	30 months
Video Surveillance Baluns	30 months
Smoke Detectors	36 months
DVR's, NVR's	60 Months excluding HDD; 36 Months HDD (included in recorder)
HD Analog Cameras	60 Months
IP Cameras	60 Months
PIR's	60 months
Analog Cables	Limited Lifetime

a. Specific Warranties for product categories are as follows :

B Connectors	Limited Lifetime
Bus Terminals	Limited Lifetime
Extension Cords	Limited Lifetime
HDMI Cables	Limited Lifetime
Jacks, Cords and Intrusion Communication Accessories	Limited Lifetime
Patch Cables	Limited Lifetime
Patch Panels & Brackets	Limited Lifetime
Raceway Conduit	Limited Lifetime
Wire Ties	Limited Lifetime
Magnetic Contacts	Limited Lifetime
Network Switches/PoE Switches	Limited Lifetime

2. EXCLUSION OF WARRANTIES, LIMITATION OF LIABILITY

THERE ARE NO WARRANTIES OR CONDITIONS, EXPRESS OR IMPLIED, OF MERCHANTABILITY, OR FITNESS FOR A PARTICULAR PURPOSE OR OTHERWISE, WHICH EXTEND BEYOND THE DESCRIPTION ON THE FACE HEREOF. TO THE FULLEST EXTENT PERMITTED BY LAW, IN NO CASE SHALL ADI BE LIABLE TO ANYONE FOR ANY (I) CONSEQUENTIAL, INCIDENTAL, INDIRECT, SPECIAL, OR PUNITIVE DAMAGES ARISING OUT OF OR RELATING IN ANY WAY TO THE PRODUCT AND/OR FOR BREACH OF THIS OR ANY OTHER WARRANTY OR CONDITION, EXPRESS OR IMPLIED, OR UPON ANY OTHER BASIS OF LIABILITY WHATSOEVER, EVEN IF THE LOSS OR DAMAGE IS CAUSED BY ADI'S OWN NEGLIGENCE OR FAULT AND EVEN IF ADI HAS BEEN ADVISED OF THE POSSIBILITY OF SUCH LOSSES OR DAMAGES. Any product description (whether in writing or made orally by ADI or ADI's agents), specifications, samples, models, bulletin, drawings, diagrams, engineering sheets, or similar materials used in connection with the Buyer's order are for the sole purpose of identifying ADI's products and shall not be construed as an express warranty or condition. Any suggestions by ADI or ADI's agents regarding use, applications or suitability of the products shall not be construed as an express warranty or condition unless confirmed to be such in writing by ADI. ADI does not represent that the products it sells may not be compromised or circumvented; that the products will prevent any personal injury or property loss by burglary, robbery, fire or otherwise, or that the products will in all cases provide adequate warning or protection. Buyer understands and will cause its customer to understand that a properly installed and maintained product is not insurance or guarantee that such will not cause or lead to personal injury or property loss. CONSEQUENTLY ADI SHALL HAVE NO LIABILITY FOR ANY PERSONAL INJURY, PROPERTY DAMAGE OR OTHER LOSS BASED ON ANY CLAIM AT ALL INCLUDING A CLAIM THAT THE PRODUCT FAILED TO GIVE WARNING. However, if ADI is held liable whether directly or indirectly for any loss or damage with respect to the products it sells, regardless of cause or origin, its maximum liability shall not in any case exceed the purchase price of the product, which shall be fixed as liquidated damages and not as a penalty and shall be the complete and exclusive remedy against ADI.

3. Limitation on Liability to Buyer's Customers.

Buyer agrees to limit liability to its customers to the fullest extent permitted by law. Buyer acknowledges that ADI shall only be deemed to give consumers of its products such statutory warranties as may be required by law and at no time shall Buyer represent to its customers and/or users of ADI products that ADI provides any additional warranties. By accepting the products, to the fullest extent permitted by law, Buyer assumes all liability for, and agrees to indemnify and hold ADI harmless against and defend ADI from, any and all suits, claims, demands, causes of action and judgments relating to damages, whether for personal injury or to personal property, suffered by any person, firm, corporation or business association, including but not limited to, Buyer's customers and/or users of the products because of any failure of the products to detect and/or warn of the danger for which the goods were designed or any other failure of the products whether or not such damages are caused or contributed to by the sold or joint concurring negligence or fault of ADI.

4. Returns

Subject to the terms and conditions listed below, during the applicable warranty period, ADI will replace Product or provide a credit at purchase at its sole option free of charge any defective products returned prepaid. Any obligations of ADI to replace Limited Lifetime warranty products pursuant to this warranty which result from defect are limited to the availability of replacement product. ADI reserves the right to replace any such products with the then currently available products, or provide a credit in its sole discretion. In the event Buyer has a problem with any ADI product, please call your local ADI branch for return instructions:

For US call 1-800-233-6261

For Canada call 877-234-7378

For Puerto Rico call 787-793-8830

Be sure to have the model number and the nature of the problem available. In the event of replacement, the return product will be credited to Buyer's account and a new invoice issued for the replacement item. ADI reserves the right to issue a credit only in lieu of replacement.

If any ADI branded products are found to be in good working order or such product's inability to function properly is a result of user damage or abuse, the product will be returned to Buyer in the same condition as received and Buyer shall be responsible for any return freight changes.

5. Governing Law

The laws of State of New York apply to this Limited Warranty.

6. Miscellaneous

Where any term of this Limited Warranty is prohibited by such laws, it shall be null and void, but the remainder of the Limited Warranty shall remain in full force and effect.

TOOLS NEEDED

Herramientas Necesarias
Outils Requis



3/16"
4.8 mm



5/16"
8 mm



SYMBOLS



Drill
Agujerear
Perçer



Level
Nivel
Niveau



Socket Wrench
Llave española
Clé ouverte



Caution
Precaución
Attention

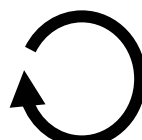

Tighten
Ajustar
Serrer



Pencil Mark
Marque con lápiz
Marque de crayon



Screwdriver
Destornillador
Tournevis



Heavy!
Tres Lourd!
!Pesado!

MONITOR PLATE AND ADAPTERS

Use diagrams to determine which mounting configuration is needed to attach monitor plate (with or without adapters) to the back of TV. Please check TV wall mounting compatibility before proceeding with installation.

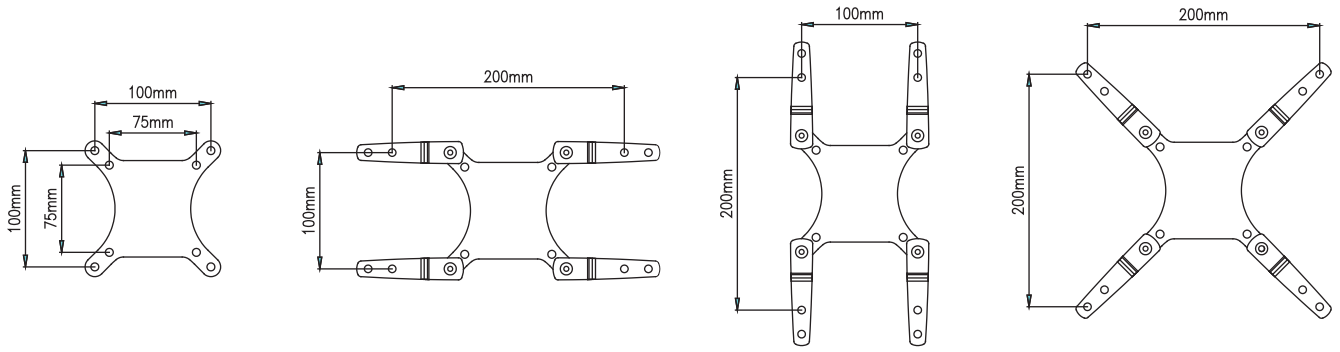

HARDWARE PART NUMBERS

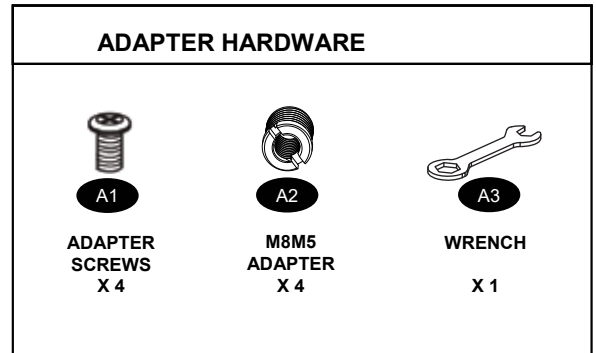
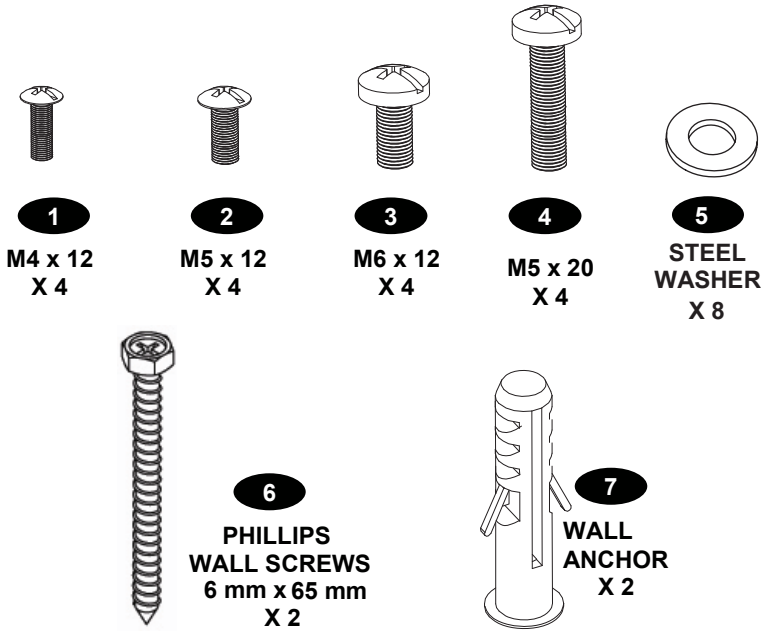

PRODUCT COMPONENT PARTS

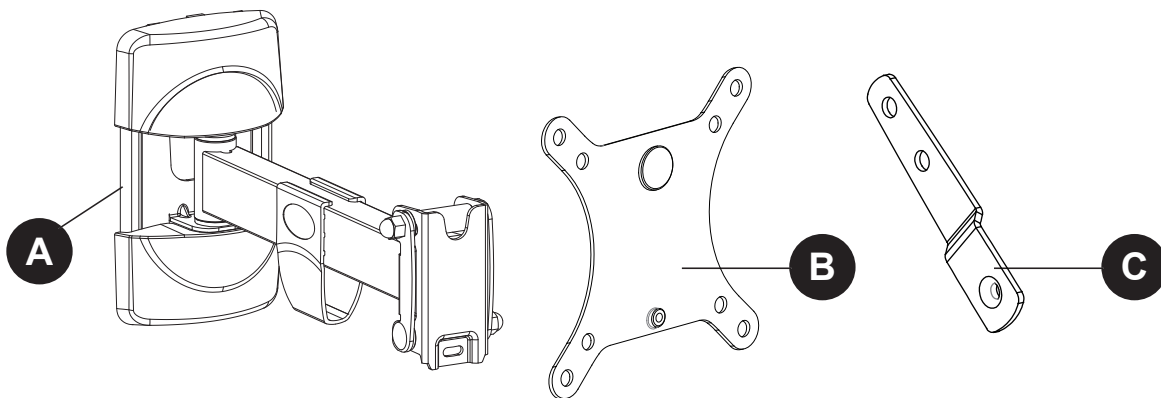

Product Components		
Contents	Qty	Description
A	1	Wall Plate
B	1	Monitor Plate
C	4	Monitor Adapters

STEP 1- REMOVE SCREW AND PLASTIC COVERS

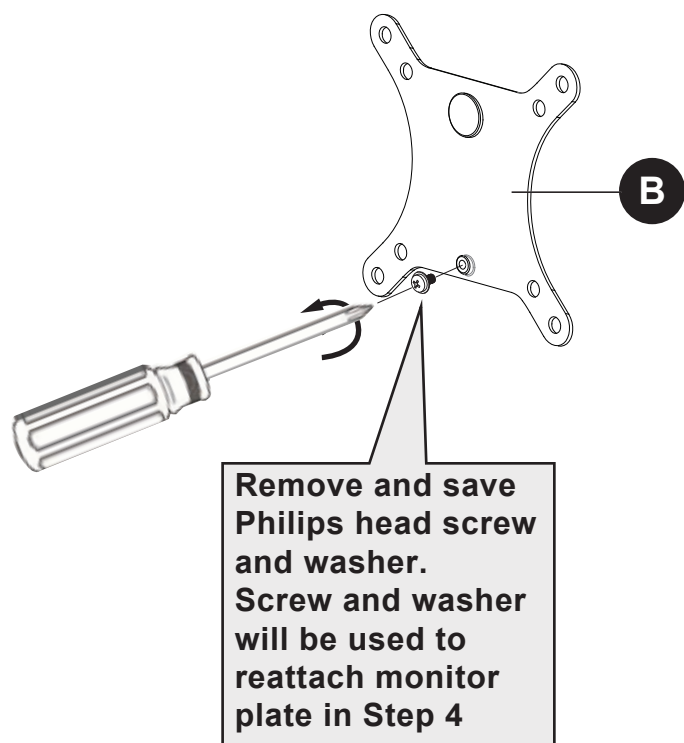

Remove and save the plastic covers. They will be used to reattach monitor plate in Step 3A and 3B.

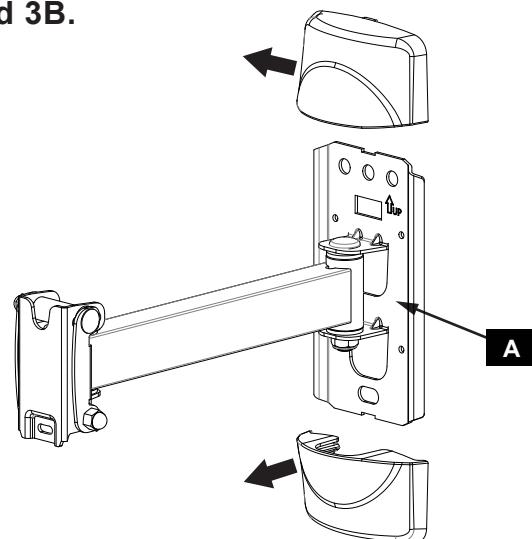

STEP 2A- MONITOR PLATE ATTACHMENT

Connect monitor plate to TV

Conecte el adaptador al monitor
Connectez l'adaptateur au moniteur

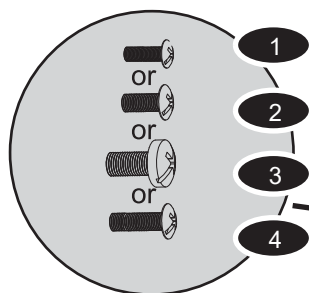

Use M8M5 adapter **A2** with 5mm x 12mm screw **2** or 5mm x 20mm **4** screw if TV has 8mm inserts. Insert **A2** into 8mm insert on back of TV then follow steps below.

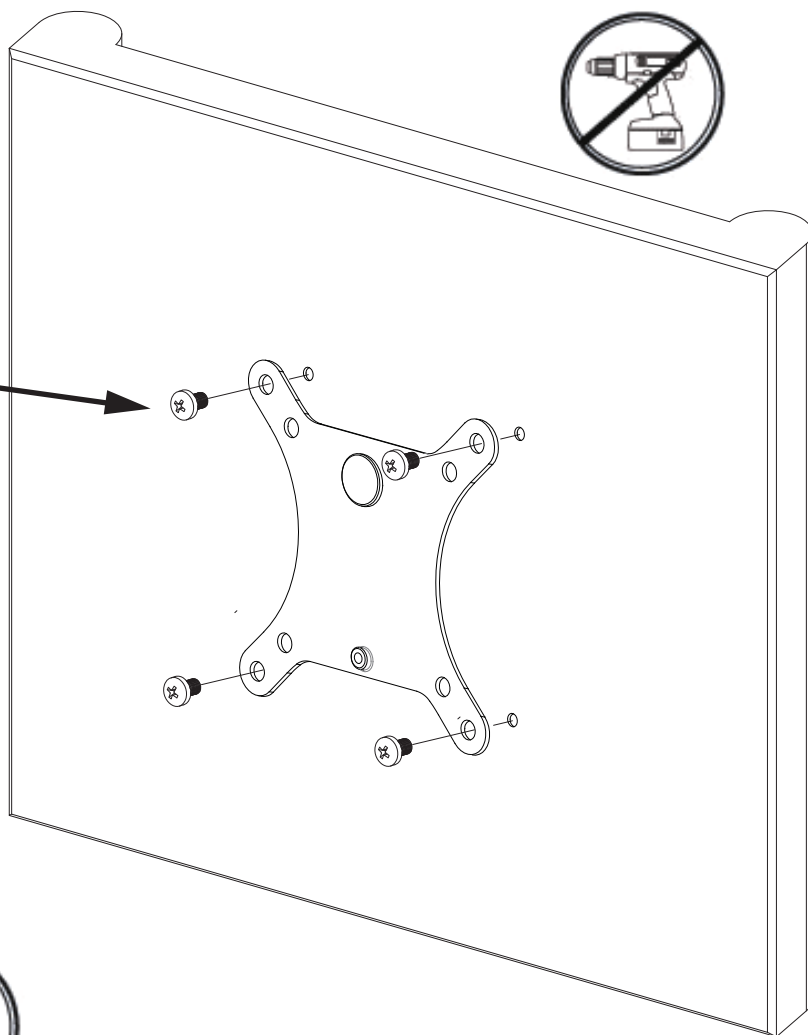

STEP 2B- MONITOR ADAPTERS ATTACHMENT TO MONITOR PLATE

Use Adapters for larger TV hole patterns

Use adaptadores para patrones de agujeros más grandes

Utilisez des adaptateurs pour configurations de trous plus grandes

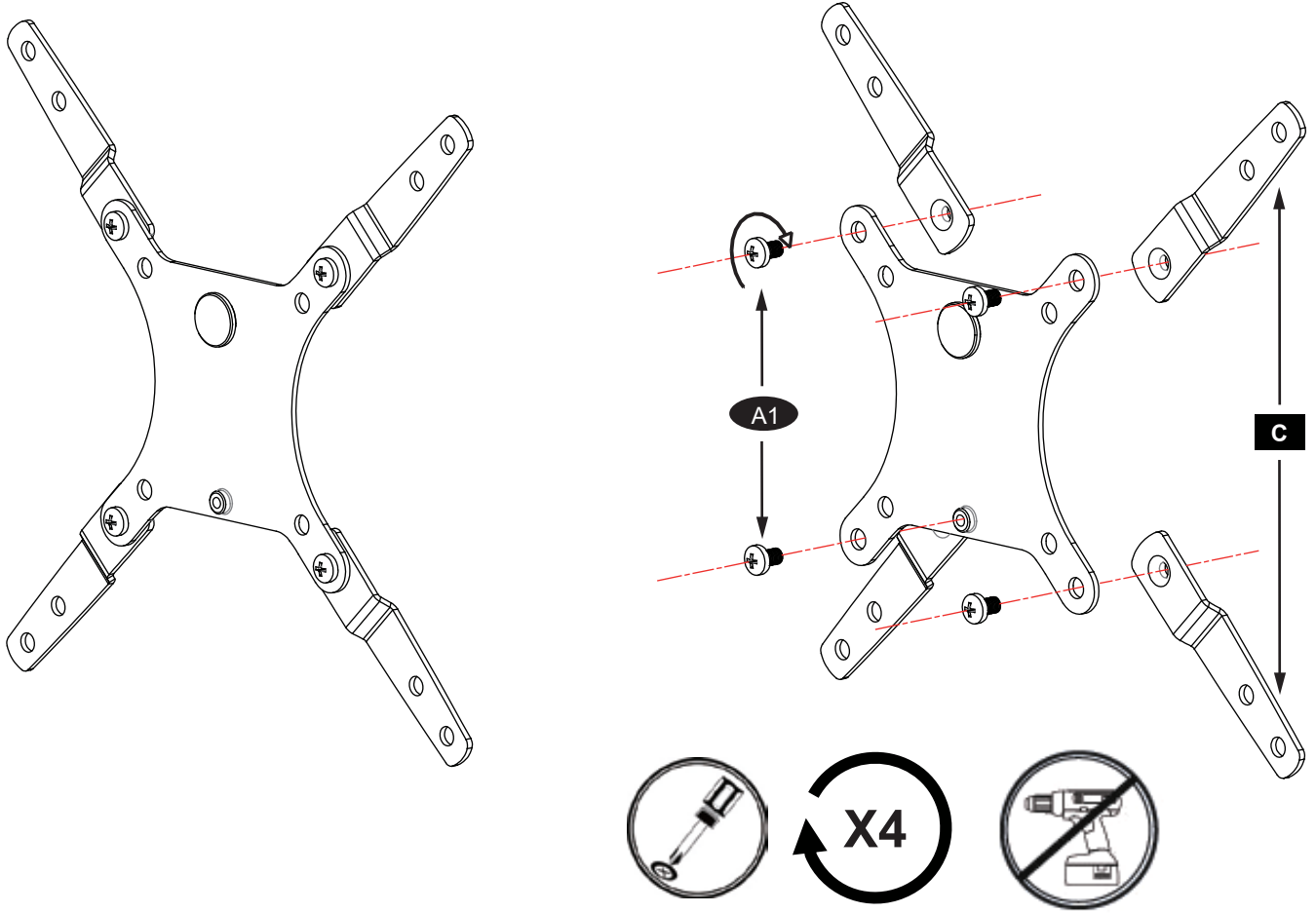

ADAPTER CONFIGURATIONS

Connect monitor plate to TV

Conecte el adaptador al monitor

Connectez l'adaptateur au moniteur

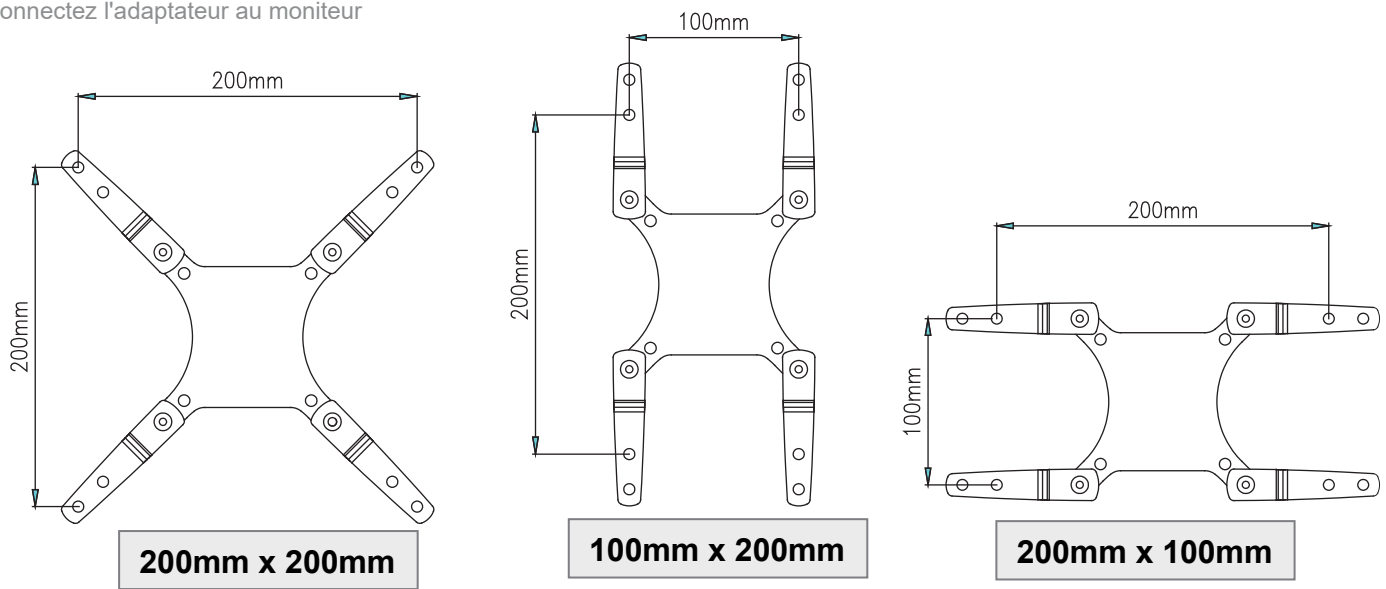

STEP 2C- USE M8 STEEL WASHER IF THE PHILLIPS SCREWS FROM THE MONITOR KIT ARE TOO LONG

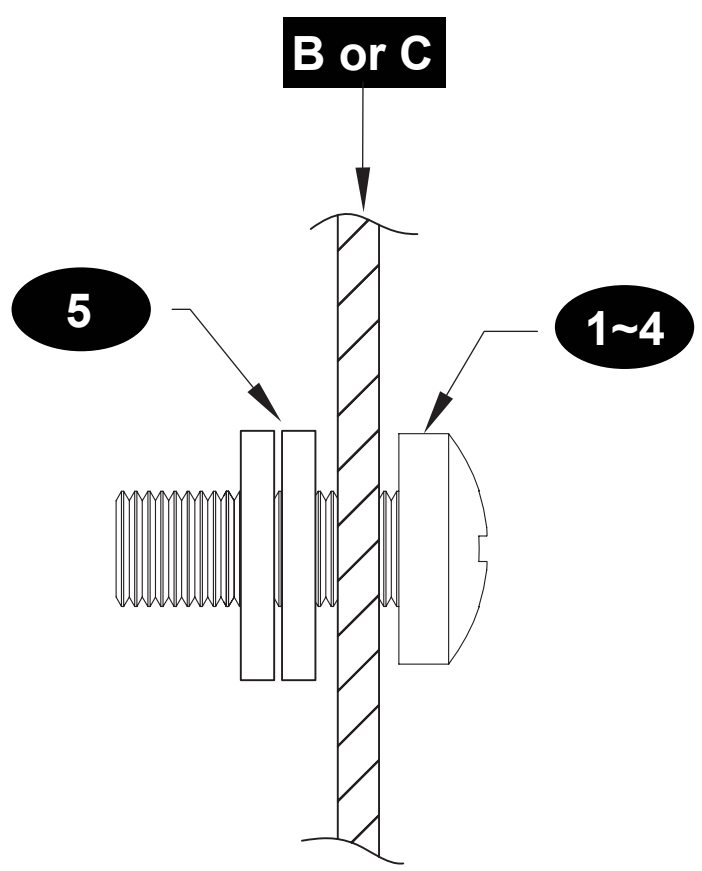
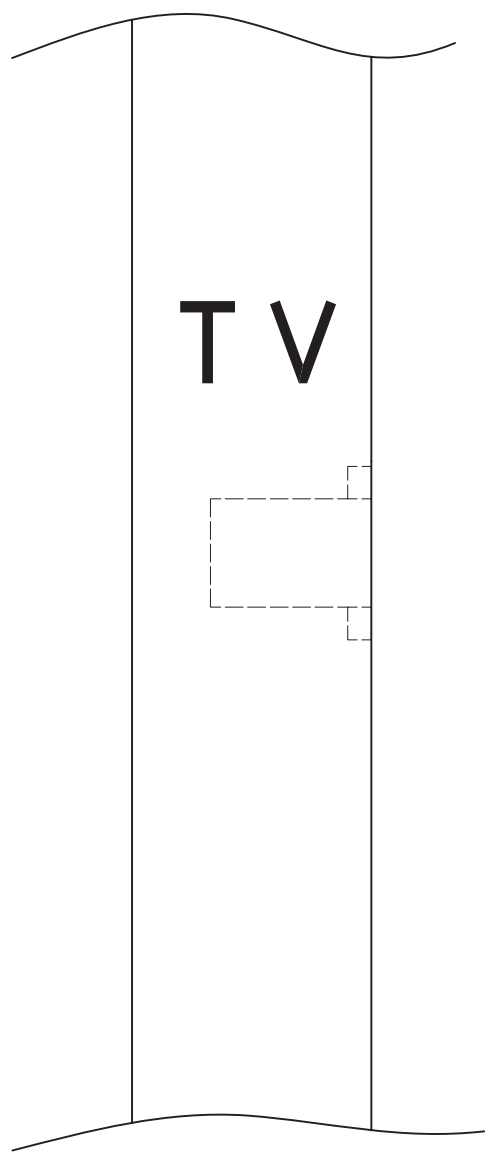

STEP 3A- WOOD STUD(CONCRETE INSTALLATION SKIP TO 3B)

Find stud and mark edge and center locations

Ubique el panel y marque las ubicaciones de los bordes y el centro.

Repérez l'emplacement d'une poutre, puis marquez l'emplacement des bords et du centre de cette poutre.

DRILL BIT
NOT INCLUDED

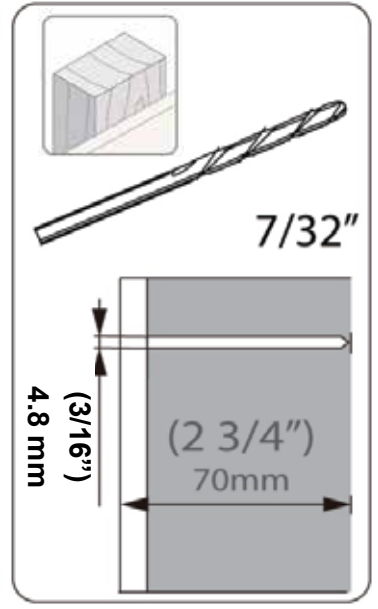
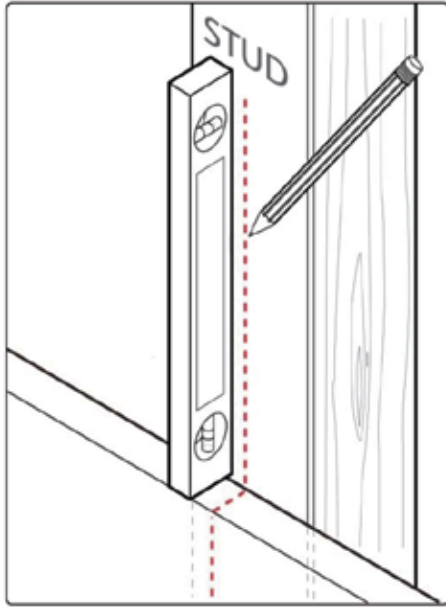
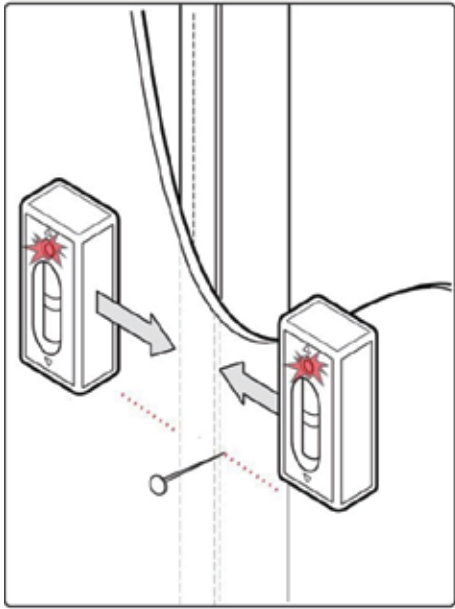

STEP 3A- DRILL PILOT HOLES AND MOUNT WALL PLATE

Mount wall plate

Coloque la placa de pared

Montez la plaque murale

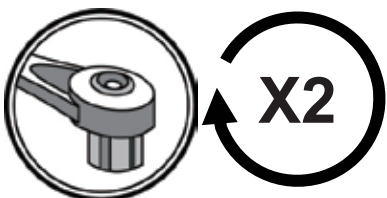
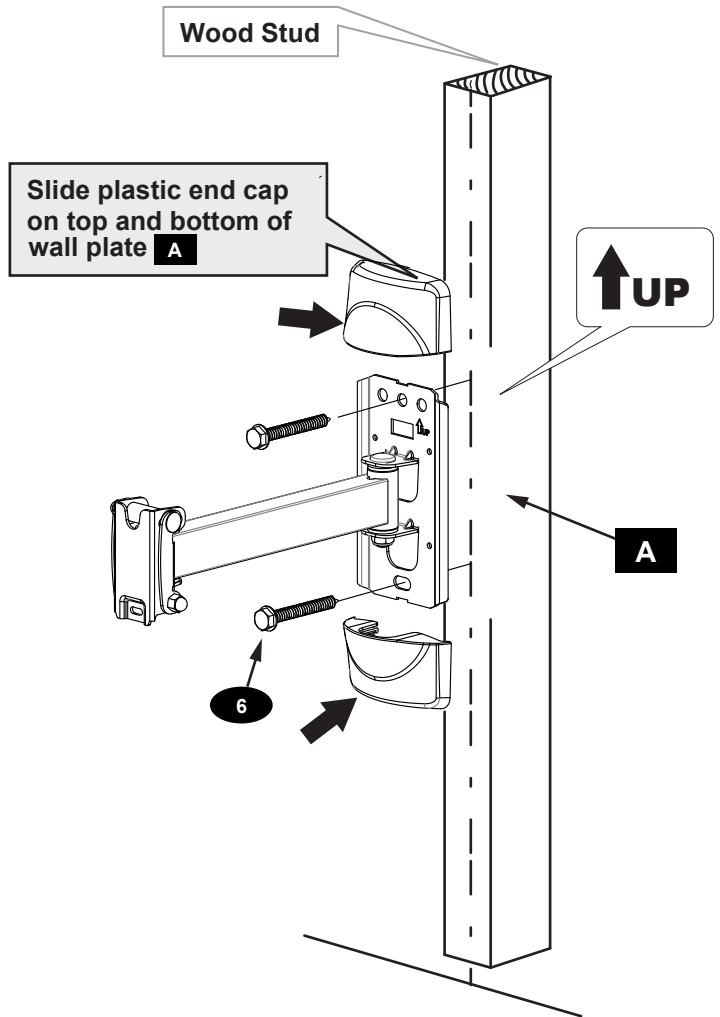
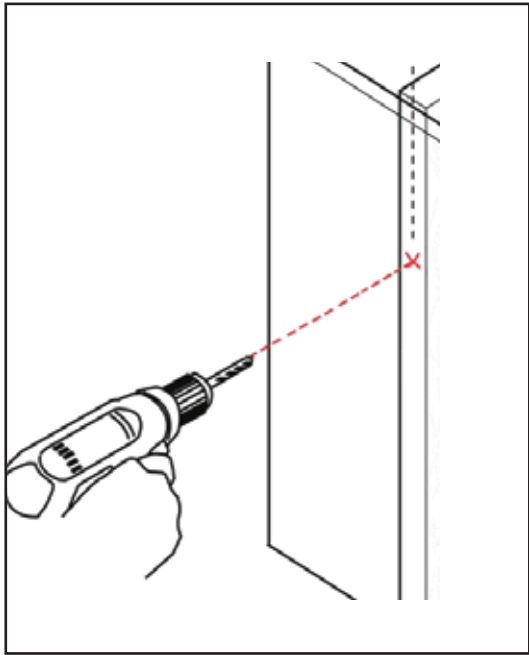

STEP 3B- SOLID CONCRETE

Level

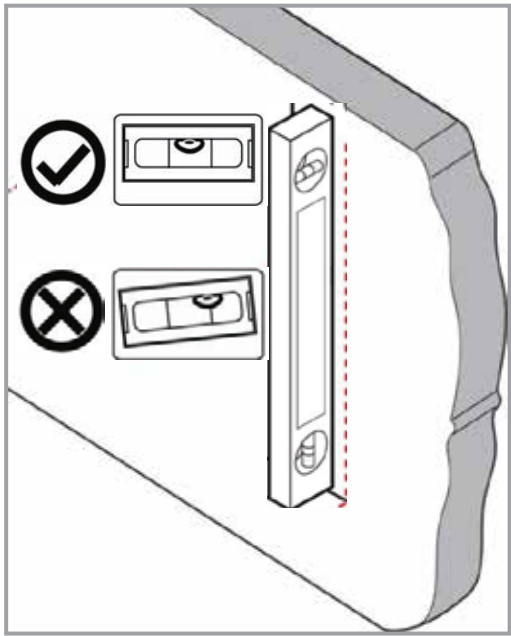

Solid concrete

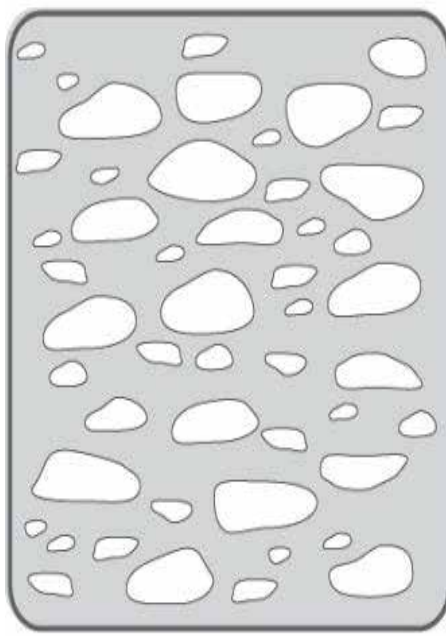

Drill bit

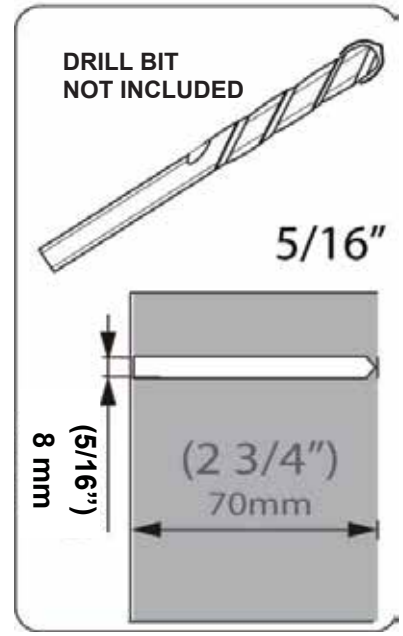

STEP 3B – DRILL PILOT HOLE AND MOUNT WALL PLATE

Drill pilot hole

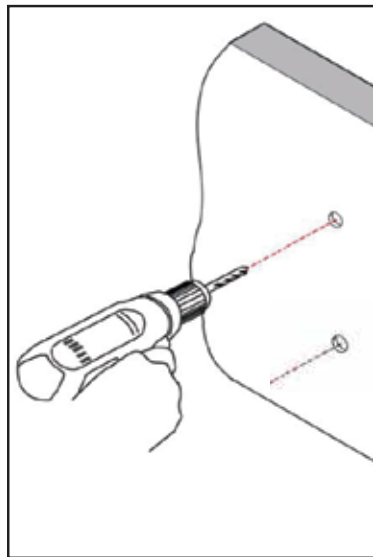

Slide plastic end cap on top and bottom of wall plate **A**

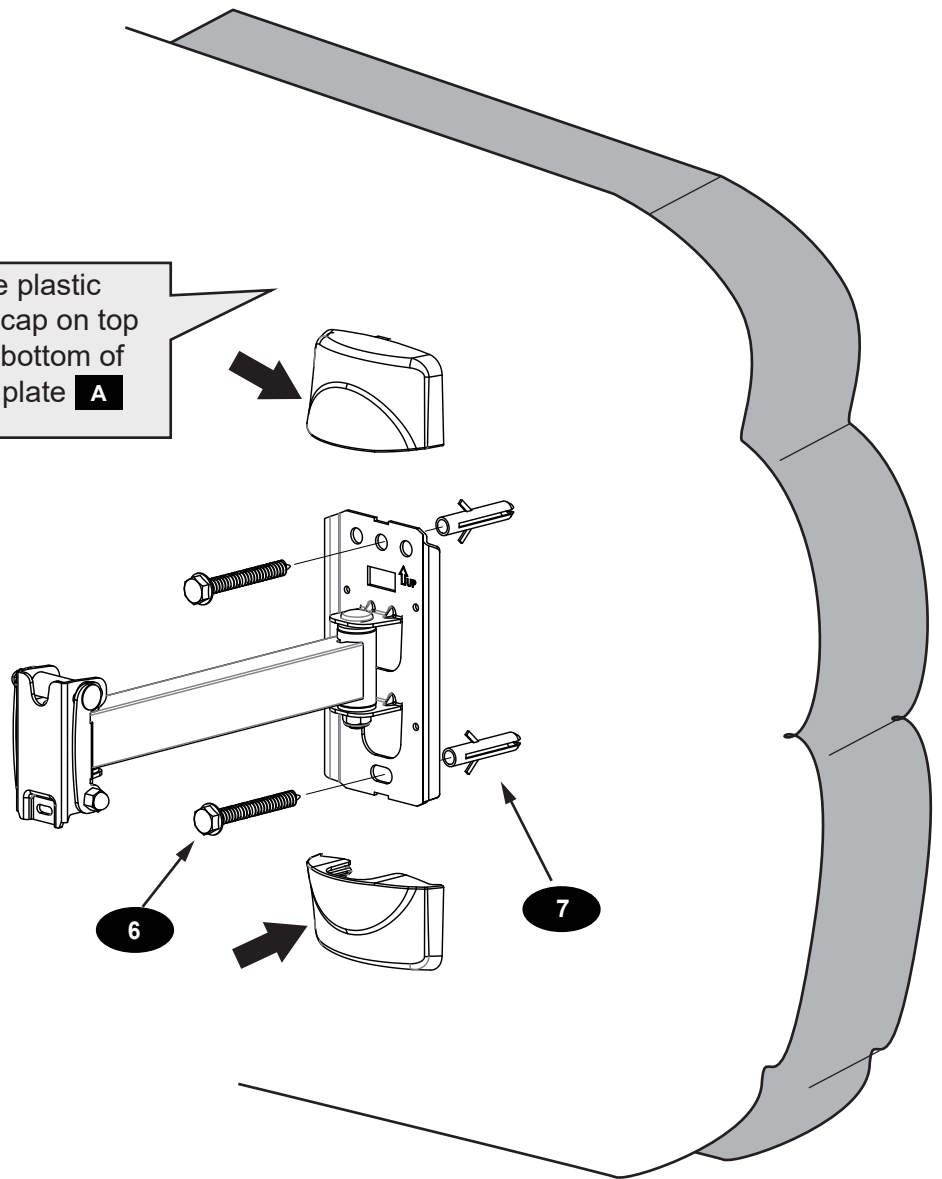

STEP 4- ATTACH PANEL TO MOUNT

Hang with monitor attached

Cuelgue con el monitor adherido.
Accrochez avec le moniteur installé.

Heavy, Assistance Required
TRES LOURD ! Cette etape requiert deux personnes
¡PESADO! Necesitara ayuda para realizar esta operacion

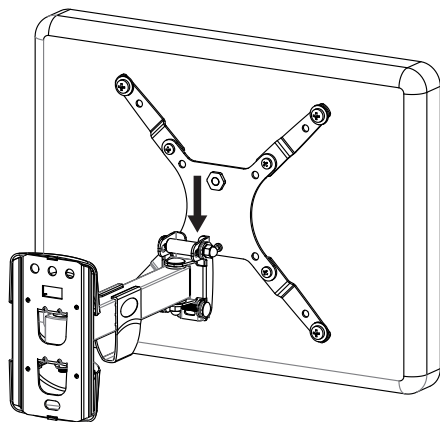

Attach the covers to the wall plate

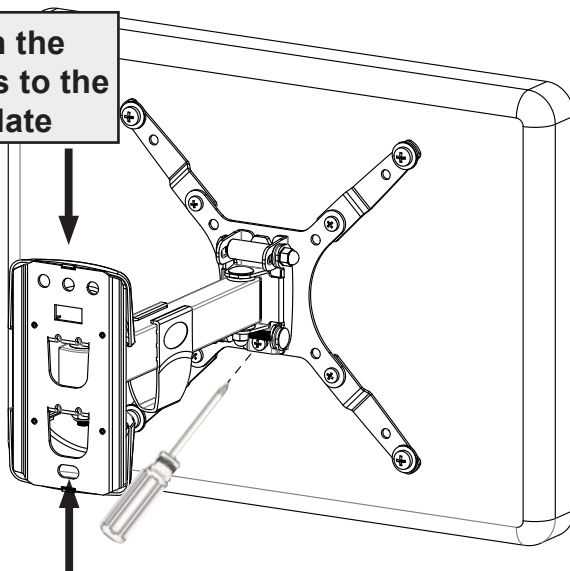

STEP 4- ADJUST TILT TENSION/ POST INSTALLATION LEVEL

Locking mechanism

Mecanismo de fijación
Mécanisme de verrouillage

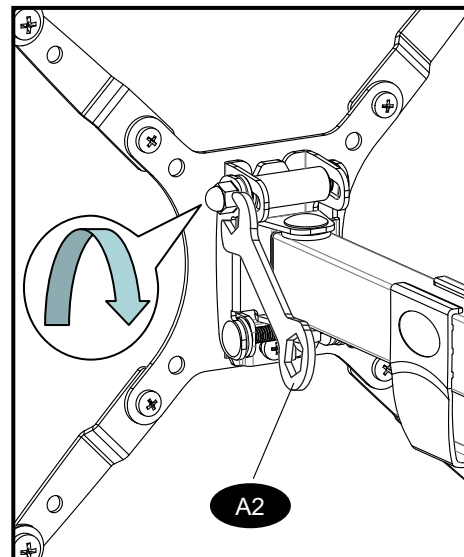
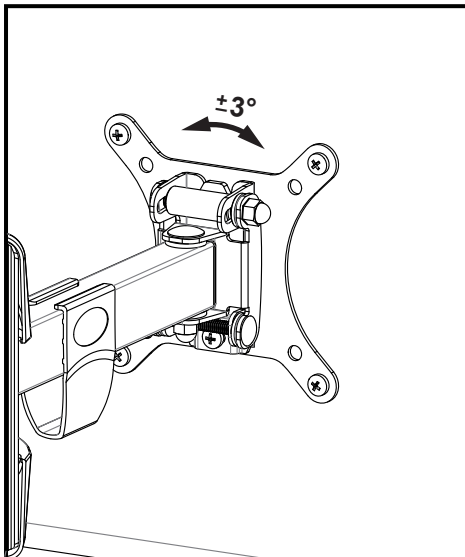
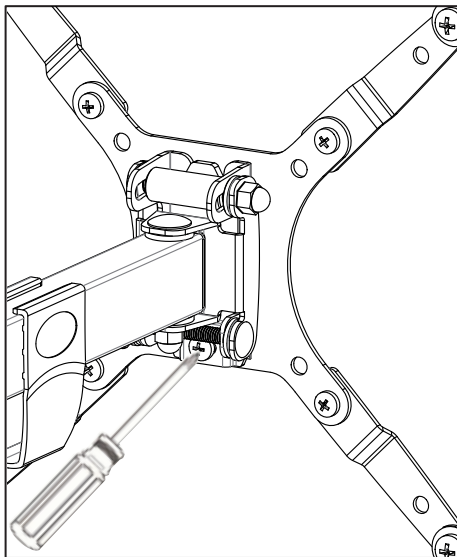

Secured monitor plate to arm using 2 Phillips head screws. Tighten only to snug tension.

Flat panel can be leveled (± 3 degrees) as needed. If security screws are tensioned tight it will be difficult to adjust leveling.

a) Loosen the nut with the wrench until panel holds desired tilt.
b) Tighten the nut with the wrench.

**CAUTION: DO NOT EXCEED MAXIMUM
WEIGHT CAPACITY. SERIOUS INJURY
OR PROPERTY DAMAGE MAY OCCUR!**
Max Loading Weight: 40 lbs

PN: NX-FMS1337



NX-FMS1337

