



Cisco Business 140AC Access Point



Thank you for choosing the Cisco Business 140AC Access Point. This access point can be used to create a new wireless network or added to an existing network to expand coverage. This Quick Start Guide will get you up and running in no time.

What's in the Box

- Cisco Business 140AC Access Point
- Mounting Kit
- Ethernet Cable
- Quick Start Guide
- Technical Support Contact List
- Pointer Card China RoHS
- Compliance Information (for EU SKU only)

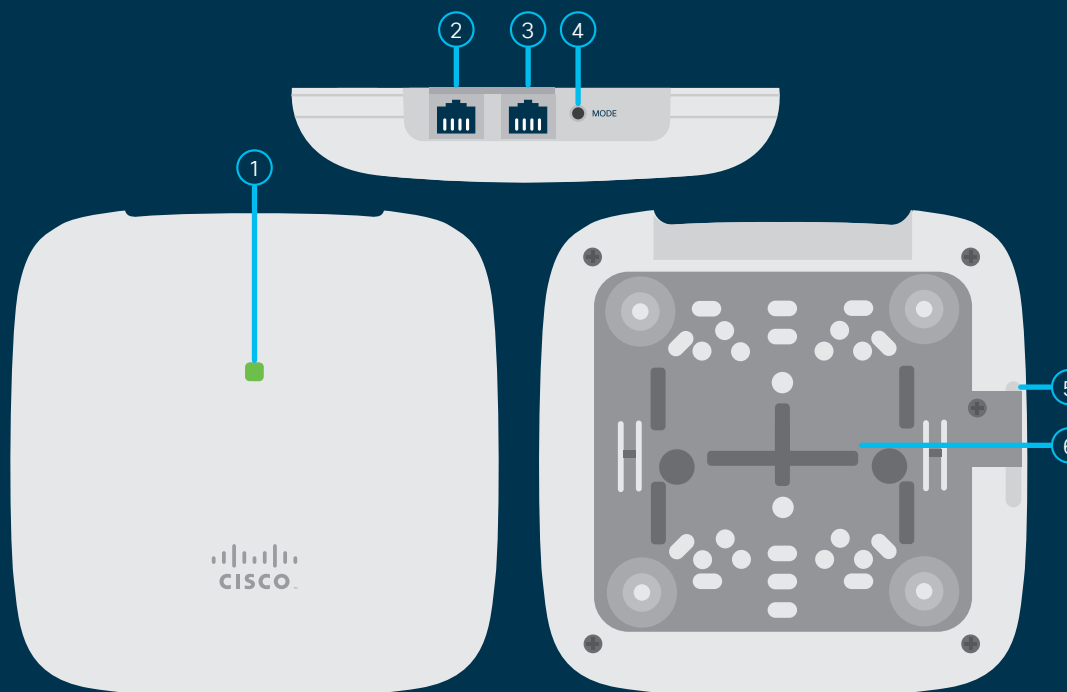

Product Features

- ① Status LED
- ② RJ-45 Console Port (For tech support only)
- ③ PoE (Power over Ethernet)-In Port (Ethernet Uplink Port)
- ④ Mode Button
- ⑤ Security Screw Hole
- ⑥ Mounting Bracket

**START
HERE**

First, You'll Need...

- An active Internet connection
- A phone or tablet with Wi-Fi capability (not connected to an active wireless network)
- A PoE (Power over Ethernet) switch, router or PoE injector (802.3af) to supply power to the access point.
- A router (to act as your DHCP Server).

Get Connected

1

Connect your access point via ethernet cable (provided) to a PoE LAN port on your switch or router. If you do not have a PoE switch or router you will need to use a PoE injector (not included).

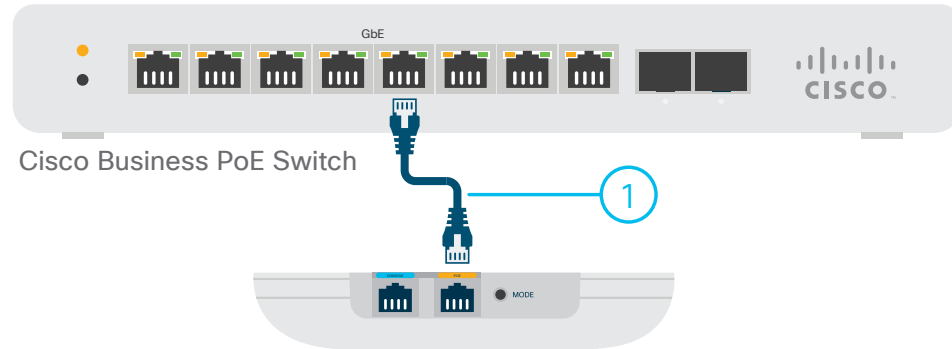

Setting up a new network or adding to an existing network?

Set up a new network

If setting up a new network the device will begin initial boot up. The LED will cycle through green, amber, and red. This is normal and can take up to 6 minutes. The device is not ready until the LED is consistently blinking green or solid green. Once this occurs you can proceed to “[Get Configured](#)”.

2

Add to an existing wireless network

Allow the access point to boot up and automatically update its firmware and configuration to match the existing network. This can take ten minutes or more and the LED will cycle through green, amber and red. This is normal. Once the LED is blinking green or solid green the setup is complete and the AP has joined the network.

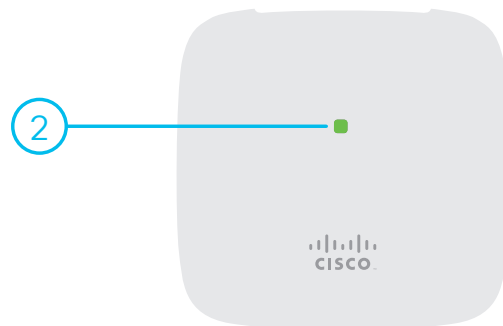

Get Configured

Download the Cisco Business Mobile app



No computer is needed for setup, just use the app on your mobile phone or tablet.

Scan the QR code here to download the app or go to cisco.com/go/app and follow the installation instructions.



Alternative: Web UI (Internet Browser) Setup

If you do not wish to use the Cisco Business Mobile app you can use the Web UI for setup. These instructions can be found online in the Web UI Setup Document.

To download the instructions see the “[Get Support](#)” section below.

Mounting and Grounding

Cisco Business Wireless access points can be mounted in several configurations—on a suspended ceiling, on a hard ceiling or wall, or in the plenum air space above a suspended ceiling.

Mounting instructions are located in the Administration Guide, see the “[Get Support](#)” section below.

Get Support



For Cisco support and additional product documentation, including the Web UI Setup Document and Administration Guide, visit:

<https://cisco.com/go/cbw140ac>