



# User Guide

© Copyright 2020 HP Development Company, L.P.

HDMI, the HDMI Logo and High-Definition Multimedia Interface are trademarks or registered trademarks of HDMI Licensing LLC. Windows is either a registered trademark or trademark of Microsoft Corporation in the United States and/or other countries. NVIDIA, the NVIDIA logo, and G-SYNC are trademarks and/or registered trademarks of NVIDIA Corporation in the U.S. and other countries. DisplayPort™, the DisplayPort™ logo, and VESA® are trademarks or registered trademarks owned by the Video Electronics Standards Association (VESA) in the United States and other countries.

The information contained herein is subject to change without notice. The only warranties for HP products and services are set forth in the express warranty statements accompanying such products and services. Nothing herein should be construed as constituting an additional warranty. HP shall not be liable for technical or editorial errors or omissions contained herein.

#### **Product notice**





This guide describes features that are common to most models. Some features may not be available on your product. To access the latest user guide, go to <http://www.hp.com/support>, and follow the instructions to find your product. Then select **User Guides**.

First Edition: April 2020

Document Part Number: M03138-001

## About this guide

This guide provides technical specifications and information about monitor features, setting up the monitor, and using the software. Depending on the model, your monitor may not have all the features included in this guide.

- 
-  **WARNING!** Indicates a hazardous situation that, if not avoided, **could** result in serious injury or death.
  -  **CAUTION:** Indicates a hazardous situation that, if not avoided, **could** result in minor or moderate injury.
  -  **IMPORTANT:** Indicates information considered important but not hazard-related (for example, messages related to property damage). Warns the user that failure to follow a procedure exactly as described could result in loss of data or in damage to hardware or software. Also contains essential information to explain a concept or to complete a task.
  -  **NOTE:** Contains additional information to emphasize or supplement important points of the main text.
  -  **TIP:** Provides helpful hints for completing a task.
- 



This product incorporates HDMI technology.



---

# Table of contents

<b>1 Getting started</b> .....	<b>1</b>
Important safety information .....	1
Product features and components .....	2
Features .....	2
Front components .....	3
Rear components .....	4
Setting up the monitor .....	5
Attaching the monitor stand .....	5
Mounting the monitor head .....	6
Removing the monitor stand .....	6
Attaching the monitor head to a mounting device .....	7
Connecting the cables .....	8
Adjusting the monitor .....	10
Turning on the monitor .....	11
Installing a security cable .....	12
<b>2 Using the monitor</b> .....	<b>13</b>
Downloading software and utilities .....	13
The Information file .....	13
The Image Color Matching file .....	13
Enabling G-SYNC compatibility (select products only) .....	14
Using the OSD menu .....	14
Using the function buttons .....	15
Reassigning the function buttons .....	15
Adjusting blue light output .....	15
Using Auto-Sleep Mode .....	16
<b>3 Support and troubleshooting</b> .....	<b>17</b>
Solving common issues .....	17
Button lockouts .....	18
Contacting support .....	18
Preparing to call technical support .....	18
Locating the serial number and product number .....	19
<b>4 Maintaining the monitor</b> .....	<b>20</b>
Maintenance guidelines .....	20

Cleaning the monitor .....	20
Shipping the monitor .....	21

**Appendix A Technical specifications ..... 22**

59.94 cm (23.6 in) model specifications .....	22
Preset display resolutions .....	22
59.94 cm (23.6 in) model .....	23
Energy saver feature .....	23

**Appendix B Accessibility ..... 25**

HP and accessibility .....	25
Finding the technology tools you need .....	25
The HP commitment .....	25
International Association of Accessibility Professionals (IAAP) .....	25
Finding the best assistive technology .....	26
Assessing your needs .....	26
Accessibility for HP products .....	26
Standards and legislation .....	27
Standards .....	27
Mandate 376 – EN 301 549 .....	27
Web Content Accessibility Guidelines (WCAG) .....	27
Legislation and regulations .....	27
Useful accessibility resources and links .....	28
Organizations .....	28
Educational institutions .....	28
Other disability resources .....	28
HP links .....	28
Contacting support .....	29

---

# 1 Getting started

## Important safety information

A power cord is included with the monitor. If you use another cord, use only a power source and connection appropriate for this monitor. For information about the correct power cord set to use with the monitor, see the *Product Notices* provided in your documentation kit.

---

 **WARNING!** To reduce the risk of electric shock or damage to the equipment:

- Plug the power cord into an AC outlet that is easily accessible at all times.
- If the power cord has a 3-pin attachment plug, plug the cord into a grounded (earthed) 3-pin outlet.
- Disconnect power from the computer by unplugging the power cord from the AC outlet. When unplugging the power cord from the AC outlet, grasp the cord by the plug.

For your safety, do not place anything on power cords or cables. Care should be taken to route all cords and cables connected to the monitor so that they cannot be stepped on, pulled, grabbed, or tripped over.

To reduce the risk of serious injury, read the *Safety & Comfort Guide* provided with your user guides. It describes proper workstation setup and proper posture, health, and work habits for computer users. The *Safety & Comfort Guide* also provides important electrical and mechanical safety information. The *Safety & Comfort Guide* is also available on the web at <http://www.hp.com/ergo>.

 **IMPORTANT:** For the protection of the monitor and the computer, connect all power cords for the computer and its peripheral devices (such as a monitor, printer, scanner) to a surge protection device such as a power strip or uninterruptible power supply (UPS). Not all power strips provide surge protection; the power strip must be specifically labeled as having this capability. Use a power strip whose manufacturer offers a damage replacement policy so that you can replace the equipment if surge protection fails.

---

Use the appropriate and correctly sized furniture designed to properly support your monitor.

 **WARNING!** Monitors that are inappropriately situated on dressers, bookcases, shelves, desks, speakers, chests, or carts could fall over and cause personal injury.

 **NOTE:** This product is suitable for entertainment purposes. Consider placing the monitor in a controlled luminous environment to avoid interference from surrounding light and bright surfaces that might cause disturbing reflections from the screen.

 **WARNING! Stability hazard:** The device might fall, causing serious personal injury or death. To prevent injury, securely attach this device to the floor or wall in accordance with the installation instructions.

 **WARNING!** This equipment is not suitable for use in locations where children are likely to be present.

---

# Product features and components

## Features

The monitor includes the following features:

- 59.94 cm (23.6 in) VA curved 1500r monitor with 1920 × 1080 @ 144 Hz resolution, ultrawide backlit display, plus full-screen support for lower resolutions
- Antiglare panel with an LED backlight
- Wide viewing angle to allow viewing from a sitting or standing position, or when moving from side to side
- Tilt and swivel adjustment capability
- Height adjustment capability
- DisplayPort™ (DP) video input
- High-Definition Multimedia Interface (HDMI) video input (cable provided)
- Audio-out (headphone) jack
- Plug and Play capability, if supported by your operating system
- Security cable slot provision on rear of monitor for optional security cable
- On-screen display (OSD) adjustments in several languages for easy setup and screen optimization
- High-bandwidth Digital Content Protection (HDCP) copy protection on all digital inputs
- VESA® mounting bracket for attaching the monitor to a wall-mount device or swing arm
- Low blue light mode settings to create a more relaxing and less stimulating image
- Energy saver feature to meet requirements for reduced power consumption



---

**NOTE:** For safety and regulatory information, see the *Product Notices* provided in your documentation kit. To access the latest user guide, go to <http://www.hp.com/support> and follow the instructions to find your product. Then select **User Guides**.

---



## Front components

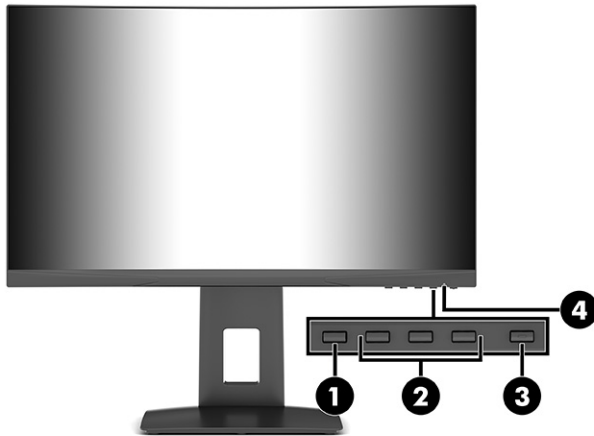

**Table 1-1** Front components

Control	Function
1 <a href="#">Menu button</a>	Press to open the OSD menu, select a menu item from the OSD, or close the OSD menu.
2    OSD buttons (assignable)	<p>When the OSD menu is open, press the buttons to navigate through the menu. The function light icons indicate the default button functions. For a description of these functions, see <a href="#">Using the function buttons on page 15</a>.</p> <p>You can reassign the function buttons to quickly select the most commonly used operations. For detailed instructions, see <a href="#">Reassigning the function buttons on page 15</a>.</p> <p><b>NOTE:</b> The function buttons are located under the monitor's front bezel edge below the power light.</p>
3    Power button	Turns the monitor on or off.
4    Power light	<p>White: The monitor is turned on.</p> <p>Amber: Monitor is in a reduced power state because of inactivity. For more information, see <a href="#">Using Auto-Sleep Mode on page 16</a>.</p>

## Rear components

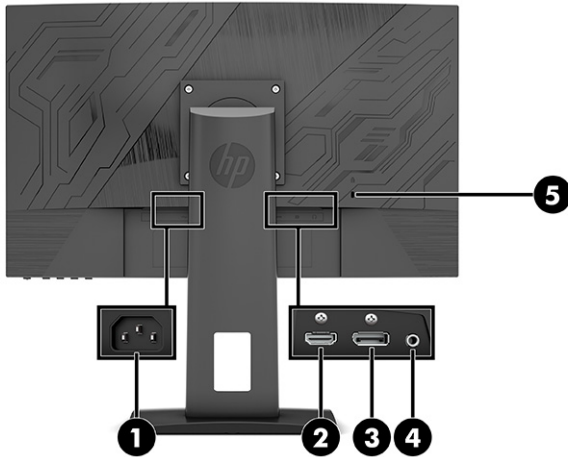

**Table 1-2** Rear components

Component	Function
1 Power connector	Connects the power cord.
2 HDMI port	Connects an HDMI cable from the monitor to a source device such as a computer.
3 DisplayPort connector	Connects the DisplayPort cable from the monitor to a source device such as a computer.
4 Headphone jack	Connects headphones to the monitor.
5 Security cable slot	Connects an optional security cable to the monitor.

## Setting up the monitor

**⚠ WARNING!** To reduce the risk of serious injury, read the *Safety & Comfort Guide*. It describes proper workstation setup and proper posture, health, and work habits for computer users. The *Safety & Comfort Guide* also provides important electrical and mechanical safety information. The *Safety & Comfort Guide* is available on the web at <http://www.hp.com/ergo>.

**📝 IMPORTANT:** To prevent damage to the monitor, do not touch the surface of the LCD panel. Pressure on the panel may cause nonuniformity of color or disorientation of the liquid crystals. If this occurs, the screen will not recover to its normal condition.

## Attaching the monitor stand

**💡 TIP:** Consider the placement of the monitor, because surrounding light and bright surfaces might cause interfering reflections.

1. With the monitor head placed facedown inside the original packing box, attach the stand to the back of the monitor head using the four screws that are included with the monitor.

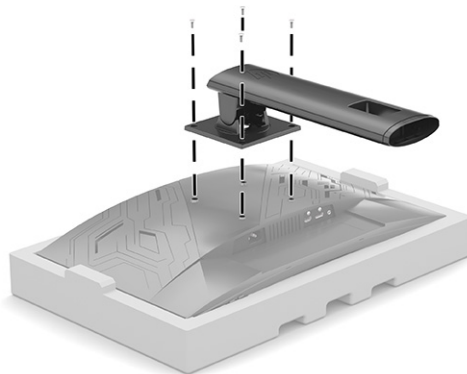

2. With the monitor still placed facedown inside the box, insert the stand into the base (1) and tighten the thumbscrew (2).

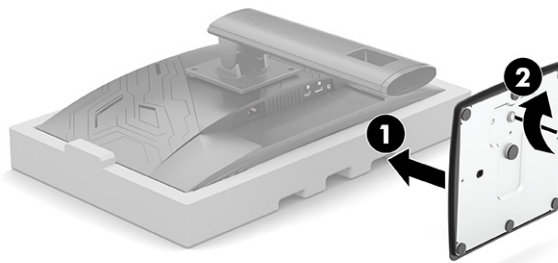

## Mounting the monitor head

The monitor head can be attached to a wall, swing arm, or other mounting fixture.

 **IMPORTANT:** This monitor supports the VESA industry-standard 100 mm mounting holes. To attach a third-party mounting solution to the monitor head, four 4 mm, 0.7 pitch, and 10 mm long screws are required. Longer screws might damage the monitor head. Be sure to verify that the manufacturer's mounting solution is compliant with the VESA standard and is rated to support the weight of the monitor head. For best performance, use the power and video cables provided with the monitor.

 **NOTE:** This apparatus is intended to be supported by a UL- or CSA-Listed wall-mount bracket.

## Removing the monitor stand

You can remove the monitor head from the stand to install the monitor head on a wall, a swing arm, or other mounting fixture.

 **IMPORTANT:** Before disassembling the monitor, be sure that the monitor is turned off and all cables are disconnected.

1. Disconnect and remove all cables from the monitor.
2. Place the monitor facedown inside the original packing box.
3. Loosen the thumbscrew under the base of the monitor stand (1), and remove the base from the stand (2).

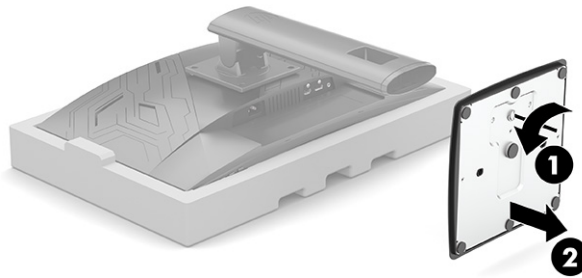

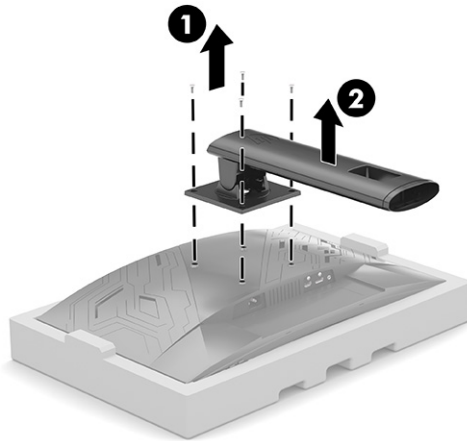

4. Remove the four screws that attach the stand to the back of the monitor (1), and lift the stand up off of the monitor head (2).

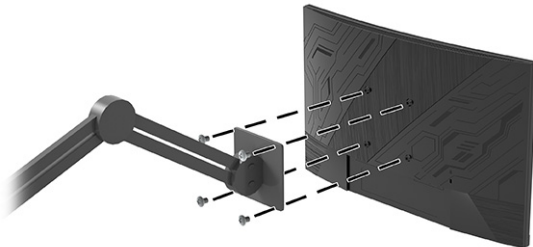

### Attaching the monitor head to a mounting device

Attach the monitor to the wall or swing arm of your choice by inserting the four new VESA screws provided with the VESA mounting bracket.



 **IMPORTANT:** Use the four new VESA screws that are attached to the new mounting bracket. Do not reuse the four VESA screws that you removed from the back of the monitor head. These screws are not long enough to provide a secure connection.

## Connecting the cables

 **NOTE:** The monitor ships with select cables. Not all cables shown in this section are included with the monitor.

1. Place the monitor in a convenient, well-ventilated location near the computer.
2. To provide a video signal to the monitor, connect an HDMI or DisplayPort video cable between the monitor and source device (computer).
  - Connect one end of an HDMI cable to the HDMI port on the rear of the monitor and the other end to the HDMI port on the source device.

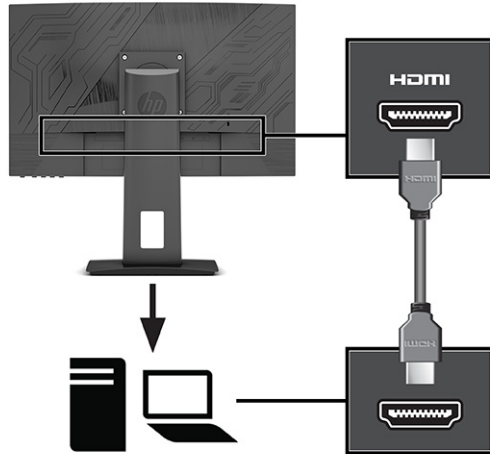

- Connect one end of a DisplayPort cable to the DisplayPort connector on the rear of the monitor and the other end to the DisplayPort connector on the source device.

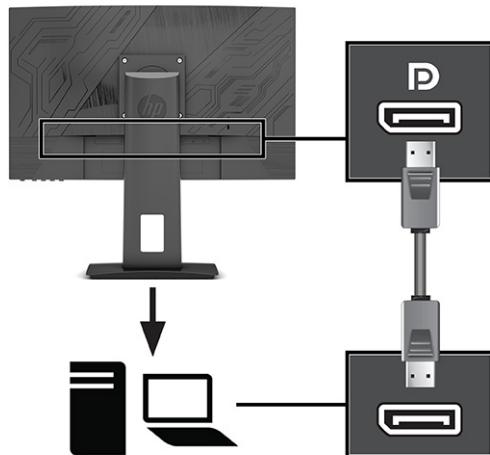

3. Connect one end of the power cord to the power connector on the rear of the monitor and the other end to a grounded AC outlet.

---

**⚠ WARNING!** To reduce the risk of electric shock or damage to the equipment:

Do not disable the power cord grounding plug. The grounding plug is an important safety feature.

Plug the power cord into a grounded (earthed) AC outlet that is easily accessible at all times.

Disconnect power from the equipment by unplugging the power cord from the AC outlet.

For your safety, do not place anything on power cords or cables. Arrange them so that no one can accidentally step on or trip over them. Do not pull on a cord or cable. When unplugging the power cord from the AC outlet, grasp the cord by the plug.

---

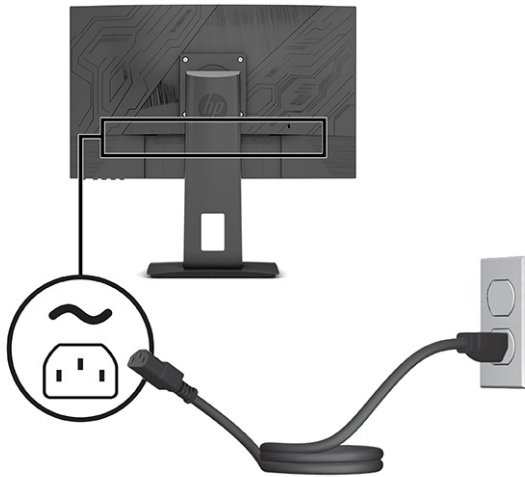

## Adjusting the monitor

**⚠ WARNING!** To reduce the risk of serious injury, read the *Safety & Comfort Guide*. It describes proper workstation setup and proper posture, health, and work habits for computer users. The *Safety & Comfort Guide* also provides important electrical and mechanical safety information. The *Safety & Comfort Guide* is available on the web at <http://www.hp.com/ergo>.

1. Tilt the monitor head forward or backward to set it to a comfortable eye level.

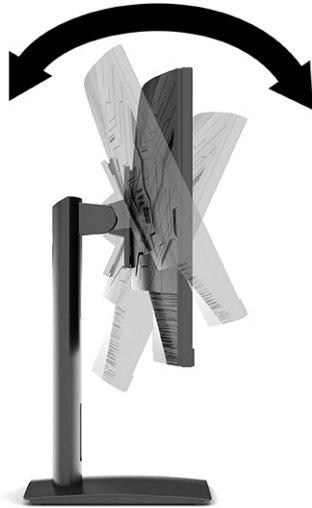

2. Adjust the monitor's height to a comfortable position for your individual workstation. The monitor's top bezel edge should not exceed a height that is parallel to your eye height. A monitor that is positioned low and reclined might be more comfortable for users with corrective lenses. Reposition your monitor as you adjust your working posture throughout the work day.

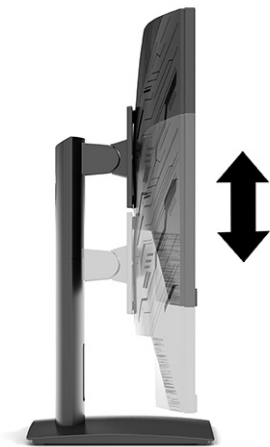



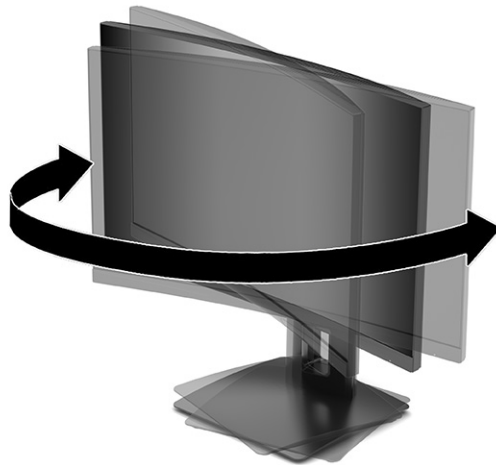

3. Swivel the monitor head to the left or right for the best viewing angle.



## Turning on the monitor

 **IMPORTANT:** Burn-in image damage may occur on monitors that display the same static image on the screen for 12 or more consecutive hours. To avoid burn-in image damage, you should always activate a screen saver application or turn off the monitor when it will not be in use for a prolonged period of time. Image retention is a condition that can occur on all LCD screens. Burn-in damage on the monitor is not covered under the HP warranty.

 **NOTE:** If pressing the power button has no effect, the Power Button Lockout feature might be enabled. To disable this feature, press and hold the monitor power button for 10 seconds.

 **NOTE:** You can disable the power light in the OSD menu. Press the **Menu** button to open the OSD, and then select **Power**, select **Power LED**, and then select **Off**.

1. Press the power button on the computer to turn it on.
2. Press the power button on the bottom of the monitor to turn it on.



When the monitor is first turned on, a monitor status message appears on the screen for 5 seconds. The message shows which input is the current active signal, the status of the auto-switch source setting (On or

Off; default setting is On), the current preset screen resolution, and the recommended preset screen resolution.

The monitor automatically scans the signal inputs for an active input and uses that input for the display.

## Installing a security cable

You can secure the monitor to a fixed object with an optional security cable available from HP.

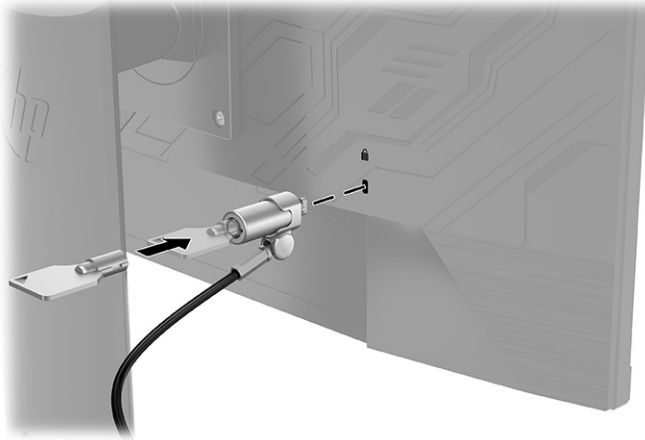

---

## 2 Using the monitor

### Downloading software and utilities

You can download and install the following files from <http://www.hp.com/support>:

- INF (Information) file
- ICM (Image Color Matching) files

To download the files:

1. Go to <http://www.hp.com/support>.
2. Select **Software and Drivers**.
3. Select your product type.
4. Enter your HP monitor model in the search field and follow the on-screen instructions.

#### The Information file

The INF file defines monitor resources used by Windows® operating systems to ensure monitor compatibility with the computer's graphics adapter.

This monitor is Windows Plug and Play-compatible, and the monitor will work correctly without installing the INF file. Monitor Plug and Play-compatibility requires that the computer's graphics card is VESA® DDC2-compliant and that the monitor connects directly to the graphics card. Plug and Play does not work through separate BNC-type connectors or through distribution buffers or boxes.

#### The Image Color Matching file

The ICM files are data files that are used in conjunction with graphics programs to provide consistent color matching from monitor screen to printer, or from scanner to monitor screen. This file is activated from within graphics programs that support this feature.



---

**NOTE:** The ICM color profile is written in accordance with the International Color Consortium (ICC) Profile Format specification.

---

## Enabling G-SYNC compatibility (select products only)

To enable G-SYNC® compatibility with your monitor, you must first install the G-SYNC driver:

1. Download the G-SYNC driver from <https://www.geforce.com/drivers> and install it.
2. After the G-SYNC driver is installed, open the **NVIDIA® Control Panel**, navigate to **Set up G-SYNC**, and select your monitor.
3. At this point, make sure both the **Enable G-SYNC, G-SYNC Compatible** check box and the **enable settings for the selected display model** check box are selected.



**NOTE:** The second check box doesn't appear if the monitor is G-SYNC certified.

4. Click **Apply**. Your monitor restarts, and Adaptive-Sync is enabled for your NVIDIA GPU.

## Using the OSD menu

Use the OSD menu to adjust the screen image based on your viewing preferences. You can access and make adjustments in the OSD menu using the buttons under the monitor's front bezel edge below the power light. See [Front components on page 3](#) for location.

To access the OSD menu and make adjustments:

1. If the monitor is not already on, press the power button to turn on the monitor.
2. Press the **Menu** button.
3. Use the three function buttons to navigate, select, and adjust the menu choices. The on-screen button labels vary depending on which menu or submenu is active.

The following table lists menu selections in the OSD main menu.

**Table 2-1 OSD main menu**

Main Menu	Description
Gaming	Adjusts game-related settings including overclocking, gaming-assist crosshair, and ambient lighting.
Color	Selects and adjusts the screen color.
Image	Adjusts the screen image.
Input	Selects the video input signal.
Power	Adjusts the power settings.
Menu	Adjusts the on-screen display (OSD) and function button controls.
Management	Adjusts the DDC/CI settings, selects the language in which the OSD menu is displayed (the factory default is English), and returns all OSD menu settings to the factory default settings.
Information	Selects and displays important information about the monitor.
Exit	Exits the OSD menu screen.

# Using the function buttons

Pressing one of the three function buttons activates the buttons and displays the icons above the buttons. The factory default button icons and functions are shown in the following table:

 **NOTE:** The actions of the function buttons vary among monitor models.

For information about changing the function of the buttons, see [Reassigning the function buttons on page 15](#).



**Table 2-2 Default button names and functions**

Button	Function
1 <a href="#">Menu</a> button	Opens the OSD main menu, selects a menu item from the OSD, or closes the OSD menu.
2 <a href="#">Brightness</a> button (Assignable function button)	Opens the <a href="#">Brightness</a> adjustment scale.
3 <a href="#">Color</a> button (Assignable function button)	Opens the <a href="#">Color</a> menu where you can adjust the monitor screen to a comfortable viewing light or select a preset viewing mode.
4 <a href="#">Next Active Input</a> button (Assignable function button)	Switches the monitor's input source to the next active input.

## Reassigning the function buttons

You can change the assignable function buttons from their default values so that when the buttons are activated, you can quickly access commonly used menu items. You cannot reassign the [Menu](#) button.

To reassign the function buttons:

1. Press the [Menu](#) button to open the OSD menu.
2. Select **Menu**, select **Assign Buttons**, and then select one of the available options for the button you want to assign.

## Adjusting blue light output

Decreasing the blue light emitted by the monitor reduces the blue light exposure to your eyes. This monitor allows you to select a setting to reduce blue light output and create a more relaxing and less stimulating image while you read content on the screen.

To adjust the blue light output from the monitor:

1. Press one of the OSD buttons to activate the buttons, and then press the [Menu](#) button to open the OSD. Select **Color**.
2. Select **Low Blue Light**.
  - **Low Blue Light:** (TÜV certified) Reduces blue light for improved eye comfort.

3. Select **Save and Return** to save your setting and close the menu. Select **Cancel** if you do not want to save the setting.
4. In the Main menu, select **Exit**.

## Using Auto-Sleep Mode

The monitor supports an OSD menu option called Auto-Sleep Mode that allows you to enable or disable a reduced power state for the monitor. When Auto-Sleep Mode is enabled (enabled by default), the monitor enters a reduced power state when the computer signals low power mode (absence of either horizontal or vertical sync signal).

Upon entering this reduced power state (Sleep mode), the monitor screen is blanked, the backlight turns off, and the power light turns amber. The monitor draws less than 0.5 W of power when in this reduced power state. The monitor wakes from Sleep mode when the computer sends an active signal to the monitor (for example, if you activate the mouse or keyboard).

To disable Auto-Sleep Mode in the OSD:

1. Press the **Menu** button to open the OSD.
2. In the OSD, select **Power**.
3. Select **Auto-Sleep Mode**, and then select **Off**.

# 3 Support and troubleshooting

## Solving common issues

The following table lists possible issues, the possible cause of each issue, and the recommended solutions.

**Table 3-1 Common issues and solutions**

Issue	Possible Cause	Solution
Screen is blank or video is flashing.	Power cord is disconnected.	Connect the power cord.
	The monitor is turned off.	Press the front bezel power button. <b>NOTE:</b> If pressing the power button has no effect, press and hold the power button for 10 seconds to disable the Power Button Lockout feature.
	Video cable is improperly connected.	Connect the video cable properly. See <a href="#">Connecting the cables on page 8</a> for more information.
	System is in Auto-Sleep Mode.	Press any key on the keyboard or move the mouse to exit Sleep mode.
	Video card is incompatible.	Open the OSD menu and select the <b>Input</b> menu. Set <b>Auto-Switch Input</b> to <b>Off</b> and manually select the input.
Image appears blurred, indistinct, or too dark.	Brightness is too low.	Open the OSD menu and select <b>Brightness</b> to adjust the brightness scale as needed.
“Check Video Cable” is displayed on the screen.	The monitor video cable is disconnected.	Connect the appropriate video signal cable between the computer and monitor. Be sure that the computer power is off while you connect the video cable.
“Input Signal Out of Range” is displayed on the screen.	Video resolution and/or refresh rate are set higher than what the monitor supports.	Change the settings to a supported setting. See <a href="#">Preset display resolutions on page 22</a> for more information.
The monitor is off but it did not seem to enter into Sleep mode.	Auto-Sleep Mode is not turned on.	Open the OSD menu and select <b>Power</b> . Then select <b>Auto-Sleep Mode</b> and set auto-sleep to <b>On</b> .
“OSD Lockout” is displayed.	The monitor's OSD Lockout function is enabled.	Press and hold the <b>Menu</b> button on the front bezel for 10 seconds to disable the OSD Lockout function.
“Power Button Lockout” is displayed.	The monitor's Power Button Lockout function is enabled.	Press and hold the power button for 10 seconds to disable the Power Button Lockout function.
The desktop computer does not turn on.	The monitor is turned off.	Be sure that the monitor power cord is plugged into an AC outlet and press the monitor power button.
	The monitor is in Sleep mode.	Press any key on the keyboard or move the mouse to exit Sleep mode.
	The Windows display orientation is not set properly.	Right-click the Windows desktop and select <b>Display settings</b> . Select <b>Identify</b> and be sure that the host computer displays are oriented left to right as they are physically arranged.

## Button lockouts

Holding down the power button or **Menu** button for 10 seconds locks out the functionality of the buttons. You can restore the functionality by holding the buttons down again for 10 seconds. This functionality is available only when the monitor is turned on, displaying an active signal, and the OSD is not open.

## Contacting support

To resolve a hardware or software problem, go to <http://www.hp.com/support>. Use this site to get more information about your product, including links to discussion forums and instructions on troubleshooting. You can also find information on how to contact HP and open a support case.



**NOTE:** The monitor user guide, reference material, and drivers are available at <http://www.hp.com/support>.

## Preparing to call technical support

If you cannot solve a problem using the troubleshooting tips in this section, you may need to call technical support. Have the following information available when you call:

- Monitor model number
- Monitor serial number
- Purchase date on invoice
- Conditions under which the problem occurred
- Error messages received
- Hardware configuration
- Name and version of the hardware and software you are using



## Locating the serial number and product number

Depending on the product, the serial number and product number are located on a label on the rear of the monitor or on a label under the front bezel of the monitor head. You might need these numbers when contacting HP about the monitor.

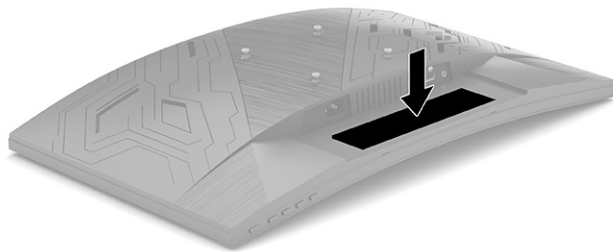

---

## 4 Maintaining the monitor

### Maintenance guidelines

To enhance the performance and extend the life of the monitor:

- Do not open the monitor cabinet or attempt to service this product yourself. Adjust only those controls that are covered in the operating instructions. If the monitor is not operating properly or has been dropped or damaged, contact an authorized HP dealer, reseller, or service provider.
- Use only a power source and connection appropriate for this monitor, as indicated on the label or back plate of the monitor.
- Be sure that the total ampere rating of the products connected to the outlet does not exceed the current rating of the AC outlet and that the total ampere rating of the products connected to the cord does not exceed the rating of the cord. Look on the power label to determine the ampere rating (AMPS or A) for each device.
- Install the monitor near an outlet that you can easily reach. Disconnect the monitor by grasping the plug firmly and pulling it from the outlet. Never disconnect the monitor by pulling the cord.
- Turn the monitor off when it is not in use and use a screen saver program. Doing this can substantially increase the life expectancy of the monitor.



**NOTE:** A burned-in image on the monitor is not covered under the HP warranty.

---

- Never block the slots and openings of the cabinet or push objects into them. These openings provide ventilation.
- Do not drop the monitor or place it on an unstable surface.
- Do not allow anything to rest on the power cord. Do not walk on the cord.
- Keep the monitor in a well-ventilated area, away from excessive light, heat, or moisture.

### Cleaning the monitor

1. Turn off the monitor and unplug the power cord from the AC outlet.
2. Disconnect any external devices.
3. Dust the monitor by wiping the screen and the cabinet with a soft, clean antistatic cloth.
4. For more difficult cleaning situations, use a 50/50 mix of water and isopropyl alcohol.



**IMPORTANT:** Do not use cleaners that contain any petroleum-based materials such as benzene, thinner, or any volatile substance to clean the monitor screen or cabinet. These chemicals may damage the monitor.

**IMPORTANT:** Spray the cleaner onto a cloth and use the damp cloth to gently wipe the screen surface. Never spray the cleaner directly on the screen surface. It may run behind the bezel and damage the electronics. The cloth should be moist, but not wet. Water dripping into the ventilation openings or other points of entry can cause damage to the monitor. Allow the monitor to air-dry before use.

---

## Shipping the monitor

Keep the original packing box in a storage area. You may need it later if you remove or attach the stand, ship the monitor, or move.

# A Technical specifications



**NOTE:** All specifications represent the typical specifications provided by HP's component manufacturers; actual performance may vary either higher or lower.

For the latest specifications or additional specifications on this product, go to <http://www.hp.com/go/quickspecs/> and search for your specific monitor model to find the model-specific QuickSpecs.

## 59.94 cm (23.6 in) model specifications

**Table A-1 59.94 cm (23.6 in) model specifications**

Specification	Measurement	
<b>Display</b>	<b>59.94 cm wide screen</b>	23.6 in wide screen
Type	VA	
<b>Viewable image size</b>	<b>59.94 cm diagonal</b>	23.6 in diagonal
<b>Maximum weight (unpacked)</b>	<b>5.32 kg</b>	11.73 lb
<b>Dimensions</b>		
Height	<b>48.88 cm</b>	19.24 in
Depth	<b>21.80 cm</b>	8.58 in
Width	<b>53.62 cm</b>	21.11 in
Tilt	-5° to 23°	
<b>Environmental requirements temperature</b>		
Operating temperature	<b>5°C to 35°C</b>	41°F to 95°F
Storage temperature	<b>-20°C to 60°C</b>	-4°F to 140°F
Storage humidity	35% to 75%	
<b>Power source</b>	100 V ac to 240 V ac 50/60 Hz 0.8 A	
<b>Input terminal</b>	One HDMI port and one DisplayPort connector	

## Preset display resolutions

The display resolutions listed in the following table are the most commonly used modes and are set as factory defaults. The monitor automatically recognizes these preset modes, and they will appear properly sized and centered on the screen.

## 59.94 cm (23.6 in) model

**Table A-2 Preset display resolutions**

Preset	Pixel format	Horz freq (kHz)	Vert freq (Hz)
1	640 × 480	31.469	59.940
2	720 × 400	31.469	70.087
3	800 × 600	37.879	60.317
4	1024 × 768	48.363	60.004
5	1024 × 768	60.023	75.029
6	1280 × 720	45.000	60.000
7	1280 × 800	49.702	59.810
8	1280 × 1024	63.981	60.020
9	1440 × 900	55.935	59.887
10	1600 × 900	60.000	60.000
11	1680 × 1050	65.290	59.954
12	1920 × 1080	67.500	60.000
13	1920 × 1080	95.433	84.905
14	1920 × 1080	112.500	100.000
15	1920 × 1080	135.000	120.000
16	1920 × 1080	166.587	143.982

**Table A-3 Preset timing resolutions**

Preset	Timing name	Pixel format	Horz freq (kHz)	Vert freq (Hz)
1	480p	720 × 480	31.469	59.94
2	576p	720 × 576	31.250	50.00
3	720p50	1280 × 720	37.500	50.00
4	720p60	1280 × 720	45.000	60.00
5	1080p50	1920 × 1080	56.250	50.00
6	1080p60	1920 × 1080	67.500	60.00
7	1080p100	1920 × 1080	112.500	100.00
8	1080p120	1920 × 1080	135.000	120.00

## Energy saver feature

The monitor supports a reduced power state. The reduced power state is initiated if the monitor detects the absence of either the horizontal sync signal or the vertical sync signal. Upon detecting the absence of these signals, the monitor screen is blanked, the backlight is turned off, and the power light turns amber. When the

monitor is in the reduced power state, the monitor uses <0.5 W of power. There is a brief warm-up period before the monitor returns to its normal operating state.

See the computer manual for instructions on setting energy saver features (sometimes called power management features).



**NOTE:** This power saver feature works only when the monitor is connected to a computer that has energy saver features.

---

By selecting the settings in the monitor's Energy Saver utility, you can also program the monitor to enter into the reduced power state at a predetermined time. When the monitor's Energy Saver utility causes the monitor to enter the reduced power state, the power light blinks amber.

---

# B Accessibility

## HP and accessibility

Because HP works to weave diversity, inclusion, and work/life into the fabric of the company, it is reflected in everything HP does. HP strives to create an inclusive environment focused on connecting people to the power of technology throughout the world.

### Finding the technology tools you need

Technology can unleash your human potential. Assistive technology removes barriers and helps you create independence at home, at work, and in the community. Assistive technology helps increase, maintain, and improve the functional capabilities of electronic and information technology. For more information, see [Finding the best assistive technology on page 26](#).

### The HP commitment

HP is committed to providing products and services that are accessible for people with disabilities. This commitment supports the company's diversity objectives and helps ensure that the benefits of technology are available to all.

The HP accessibility goal is to design, produce, and market products and services that can be effectively used by everyone, including people with disabilities, either on a stand-alone basis or with appropriate assistive devices.

To achieve that goal, this Accessibility Policy establishes seven key objectives to guide HP actions. All HP managers and employees are expected to support these objectives and their implementation in accordance with their roles and responsibilities:

- Raise the level of awareness of accessibility issues within HP, and provide employees with the training they need to design, produce, market, and deliver accessible products and services.
- Develop accessibility guidelines for products and services, and hold product development groups accountable for implementing these guidelines where competitively, technically, and economically feasible.
- Involve people with disabilities in the development of accessibility guidelines and in the design and testing of products and services.
- Document accessibility features, and make information about HP products and services publicly available in an accessible form.
- Establish relationships with leading assistive technology and solution providers.
- Support internal and external research and development that improves assistive technology relevant to HP products and services.
- Support and contribute to industry standards and guidelines for accessibility.

### International Association of Accessibility Professionals (IAAP)

IAAP is a not-for-profit association focused on advancing the accessibility profession through networking, education, and certification. The objective is to help accessibility professionals develop and advance their careers and to better enable organizations to integrate accessibility into their products and infrastructure.

As a founding member, HP joined to participate with other organizations to advance the field of accessibility. This commitment supports HP's accessibility goal of designing, producing, and marketing products and services that people with disabilities can effectively use.

IAAP will make the profession strong by globally connecting individuals, students, and organizations to learn from one another. If you are interested in learning more, go to <http://www.accessibilityassociation.org> to join the online community, sign up for newsletters, and learn about membership options.

## Finding the best assistive technology

Everyone, including people with disabilities or age-related limitations, should be able to communicate, express themselves, and connect with the world using technology. HP is committed to increasing accessibility awareness within HP and with our customers and partners. Whether it's large fonts that are easy on the eyes, voice recognition that lets you give your hands a rest, or any other assistive technology to help with your specific situation—a variety of assistive technologies make HP products easier to use. How do you choose?

## Assessing your needs

Technology can unleash your potential. Assistive technology removes barriers and helps you create independence at home, at work, and in the community. Assistive technology (AT) helps increase, maintain, and improve the functional capabilities of electronic and information technology.

You can choose from many AT products. Your AT assessment should allow you to evaluate several products, answer your questions, and facilitate your selection of the best solution for your situation. You will find that professionals qualified to do AT assessments come from many fields, including those licensed or certified in physical therapy, occupational therapy, speech/language pathology, and other areas of expertise. Others, while not certified or licensed, can also provide evaluation information. You will want to ask about the individual's experience, expertise, and fees to determine if they are appropriate for your needs.

## Accessibility for HP products

The following links provide information about accessibility features and assistive technology, if applicable, included in various HP products. These resources will help you select the specific assistive technology features and product(s) most appropriate for your situation.

- [HP Elite x3—Accessibility Options \(Windows 10 Mobile\)](#)
- [HP PCs—Windows 7 Accessibility Options](#)
- [HP PCs—Windows 8 Accessibility Options](#)
- [HP PC's—Windows 10 Accessibility Options](#)
- [HP Slate 7 Tablets—Enabling Accessibility Features on Your HP Tablet \(Android 4.1/Jelly Bean\)](#)
- [HP SlateBook PCs—Enabling Accessibility Features \(Android 4.3, 4.2/Jelly Bean\)](#)
- [HP Chromebook PCs—Enabling Accessibility Features on Your HP Chromebook or Chromebox \(Chrome OS\)](#)
- [HP Shopping—peripherals for HP products](#)

If you need additional support with the accessibility features on your HP product, see [Contacting support on page 29](#).

Additional links to external partners and suppliers that may provide additional assistance:

- [Microsoft Accessibility information \(Windows 7, Windows 8, Windows 10, Microsoft Office\)](#)
- [Google Products accessibility information \(Android, Chrome, Google Apps\)](#)



- [Assistive Technologies sorted by impairment type](#)
- [Assistive Technology Industry Association \(ATIA\)](#)

## Standards and legislation

### Standards

Section 508 of the Federal Acquisition Regulation (FAR) standards was created by the US Access Board to address access to information and communication technology (ICT) for people with physical, sensory, or cognitive disabilities. The standards contain technical criteria specific to various types of technologies, as well as performance-based requirements which focus on functional capabilities of covered products. Specific criteria cover software applications and operating systems, web-based information and applications, computers, telecommunications products, video and multimedia, and self-contained closed products.

### Mandate 376 – EN 301 549

The EN 301 549 standard was created by the European Union within Mandate 376 as the basis for an online toolkit for public procurement of ICT products. The standard specifies the functional accessibility requirements applicable to ICT products and services, together with a description of the test procedures and evaluation methodology for each accessibility requirement.

### Web Content Accessibility Guidelines (WCAG)

Web Content Accessibility Guidelines (WCAG) from the W3C's Web Accessibility Initiative (WAI) helps web designers and developers create sites that better meet the needs of people with disabilities or age-related limitations. WCAG advances accessibility across the full range of web content (text, images, audio, and video) and web applications. WCAG can be precisely tested, is easy to understand and use, and allows web developers flexibility for innovation. WCAG 2.0 has also been approved as [ISO/IEC 40500:2012](#).

WCAG specifically addresses barriers to accessing the web experienced by people with visual, auditory, physical, cognitive, and neurological disabilities, and by older web users with accessibility needs. WCAG 2.0 provides characteristics of accessible content:

- **Perceivable** (for instance, by addressing text alternatives for images, captions for audio, adaptability of presentation, and color contrast)
- **Operable** (by addressing keyboard access, color contrast, timing of input, seizure avoidance, and navigability)
- **Understandable** (by addressing readability, predictability, and input assistance)
- **Robust** (for instance, by addressing compatibility with assistive technologies)

### Legislation and regulations

Accessibility of IT and information has become an area of increasing legislative importance. The following links provide information about key legislation, regulations, and standards.

- [United States](#)
- [Canada](#)
- [Europe](#)
- [Australia](#)
- [Worldwide](#)

## Useful accessibility resources and links

The following organizations might be good resources for information about disabilities and age-related limitations.



**NOTE:** This is not an exhaustive list. These organizations are provided for informational purposes only. HP assumes no responsibility for information or contacts you encounter on the Internet. Listing on this page does not imply endorsement by HP.

---

### Organizations

- American Association of People with Disabilities (AAPD)
- The Association of Assistive Technology Act Programs (ATAP)
- Hearing Loss Association of America (HLAA)
- Information Technology Technical Assistance and Training Center (ITTATC)
- Lighthouse International
- National Association of the Deaf
- National Federation of the Blind
- Rehabilitation Engineering & Assistive Technology Society of North America (RESNA)
- Telecommunications for the Deaf and Hard of Hearing, Inc. (TDI)
- W3C Web Accessibility Initiative (WAI)

### Educational institutions

- California State University, Northridge, Center on Disabilities (CSUN)
- University of Wisconsin - Madison, Trace Center
- University of Minnesota computer accommodations program

### Other disability resources

- ADA (Americans with Disabilities Act) Technical Assistance Program
- ILO Global Business and Disability network
- EnableMart
- European Disability Forum
- Job Accommodation Network
- Microsoft Enable

### HP links

[Our contact webform](#)

[HP comfort and safety guide](#)

[HP public sector sales](#)

# Contacting support



**NOTE:** Support is in English only.

---

- Customers who are deaf or hard of hearing who have questions about technical support or accessibility of HP products:
  - Use TRS/VRS/WebCapTel to call (877) 656-7058 Monday through Friday, 6 a.m. to 9 p.m. Mountain Time.
- Customers with other disabilities or age-related limitations who have questions about technical support or accessibility of HP products, choose one of the following options:
  - Call (888) 259-5707 Monday through Friday, 6 a.m. to 9 p.m. Mountain Time.
  - Complete the [Contact form for people with disabilities or age-related limitations](#).