



ThinkSystem ST50 Maintenance Manual



Machine Types: 7Y48 and 7Y49

Note

Before using this information and the product it supports, be sure to read and understand the safety information and the safety instructions, which are available at:

http://thinksystem.lenovofiles.com/help/topic/safety_documentation/pdf_files.html

In addition, ensure that you are familiar with the terms and conditions of the Lenovo warranty for your server, which can be found at:

<http://datacentersupport.lenovo.com/warrantylookup>

Second Edition (November 2018)

© Copyright Lenovo 2018.

LIMITED AND RESTRICTED RIGHTS NOTICE: If data or software is delivered pursuant to a General Services Administration (GSA) contract, use, reproduction, or disclosure is subject to restrictions set forth in Contract No. GS-35F-05925

Contents

Safety iii

Safety inspection checklist iv

Chapter 1. Introduction 1

Server form factor 3

Specifications 4

Update the firmware 7

Tech Tips 7

Security advisories 7

Power on the server 8

Power off the server 8

Chapter 2. Server components 9

Front view 9

 Front panel 9

Rear view 10

System board components 13

System board jumpers 14

Dual SD card adapter module 14

Internal cable routing 15

 Cable routing for drive bay 1-3 16

 Cable routing for drive bay 4 18

 Cable routing for the RAID adapter and drives 20

 Cable routing for the power supply unit 23

 Cable routing for the fans 24

 Cable routing for the front panel 24

 Cable routing for the thermal sensor 25

Parts list 26

 Power cords 29

Chapter 3. Hardware replacement procedures 31

Installation guidelines 31

 System reliability guidelines 32

 Handling static-sensitive devices 33

CMOS battery (CR2032) replacement 33

 Remove the CMOS battery 33

 Install the CMOS battery 35

DIMM replacement 37

 Remove a DIMM 37

 DIMM installation rules 38

 Install a DIMM 40

Drive replacement 42

 Simple-swap drive replacement (bay 1-3) 43

 Optical/tape drive or drive adapter replacement (bay 4) 51

Dual SD card adapter replacement 65

 Remove the dual SD card adapter 65

 Install the dual SD card adapter 68

Fan replacement 71

 Remove the front fan 71

 Install the front fan 72

 Remove the rear fan 74

 Install the rear fan 76

Flash power module replacement 77

 Remove the flash power module 77

 Install the flash power module 80

Front bezel replacement 83

 Remove the front bezel 83

 Install the front bezel 85

Front panel replacement 86

 Remove the front panel 87

 Install the front panel 88

Heat sink and fan module replacement 90

 Remove the heat sink and fan module 90

 Install the heat sink and the fan module 93

Intrusion switch replacement 96

 Remove the intrusion switch 96

 Install the intrusion switch 97

PCIe adapter replacement 99

 Remove a PCIe adapter 99

 Install a PCIe adapter 102

Power supply unit replacement 105

 Remove the power supply unit 105

 Install the power supply unit 108

Processor replacement 112

 Remove the processor 112

 Install the processor 113

Server cover replacement 115

 Remove the server cover 115

 Install the server cover 117

System board replacement 119

 Remove the system board (trained technician only) 119

 Install the system board (trained technician only) 121

Thermal sensor replacement 123

 Remove the thermal sensor 123

 Install the thermal sensor 124

Complete the parts replacement 125

Chapter 4. Problem determination 127

Event logs	127
General problem determination procedures	127
List of POST error messages	128
Resolving suspected power problems	131
Resolving suspected Ethernet controller problems	131
Troubleshooting by symptom	132
Power on and power off problems	132
Memory problems	133
Hard disk drive problems	134
Monitor and video problems	135
Keyboard, mouse, or USB-device problems	136
Optional-device problems	137
Intermittent problems	139
Network problems	139
Observable problems	140

Software problems	142
-----------------------------	-----

Appendix A. Getting help and technical assistance143

Before you call	143
Contacting Support	144

Appendix B. Notices.145

Trademarks	146
Important notes	146
Particulate contamination	146
Telecommunication regulatory statement	147
Electronic emission notices	147
Taiwan BSMI RoHS declaration	148
Taiwan import and export contact information	148

Index149

Safety

Before installing this product, read the Safety Information.

قبل تركيب هذا المنتج، يجب قراءة الملاحظات الأمنية

Antes de instalar este produto, leia as Informações de Segurança.

在安装本产品之前，请仔细阅读 Safety Information（安全信息）。

安裝本產品之前，請先閱讀「安全資訊」。

Prije instalacije ovog produkta obavezno pročitajte Sigurnosne Upute.

Před instalací tohoto produktu si přečtěte příručku bezpečnostních instrukcí.

Læs sikkerhedsforskrifterne, før du installerer dette produkt.

Lees voordat u dit product installeert eerst de veiligheidsvoorschriften.

Ennen kuin asennat tämän tuotteen, lue turvaohjeet kohdasta Safety Information.

Avant d'installer ce produit, lisez les consignes de sécurité.

Vor der Installation dieses Produkts die Sicherheitshinweise lesen.

Πριν εγκαταστήσετε το προϊόν αυτό, διαβάστε τις πληροφορίες ασφάλειας (safety information).

לפני שתתקינו מוצר זה, קראו את הוראות הבטיחות.

A termék telepítése előtt olvassa el a Biztonsági előírásokat!

Prima di installare questo prodotto, leggere le Informazioni sulla Sicurezza.

製品の設置の前に、安全情報をお読みください。

본 제품을 설치하기 전에 안전 정보를 읽으십시오.

Пред да се инсталира овој продукт, прочитајте информацијата за безбедност.

بھت
ہو
ہو
ہو
ہو
ہو
ہو
ہو
ہو
ہو
ہو

Les sikkerhetsinformasjonen (Safety Information) før du installerer dette produktet.

Przed zainstalowaniem tego produktu, należy zapoznać się z książką "Informacje dotyczące bezpieczeństwa" (Safety Information).

Antes de instalar este produto, leia as Informações sobre Segurança.

Перед установкой продукта прочтите инструкции по технике безопасности.

Pred inštaláciou tohto zariadenia si pečítajte Bezpečnostné predpisy.

Pred namestitvijo tega proizvoda preberite Varnostne informacije.

Antes de instalar este producto, lea la información de seguridad.

Läs säkerhetsinformationen innan du installerar den här produkten.

ཐོན་ཁུངས་འདི་བདེ་སྤྱོད་མ་བྱས་གོང་། རྫོང་གི་ཡིད་གཟབ་
བྱ་འདྲ་མིན་ཡོད་པའི་འོད་སྤེར་བལྟ་དགོས།

Bu ürünü kurmadan önce güvenlik bilgilerini okuyun.

مەزكۇر مەھسۇلاتنى ئورنىتىشتىن بۇرۇن بىخەتەرلىك ئۇچۇرلىرىنى ئوقۇپ چىقىڭ.

Youq mwngz yungh canjbinj neix gaxgonq, itdingh aeu doeg aen
canjbinj soengq cungj vahgangj ancien siusik.

Safety inspection checklist

Use the information in this section to identify potentially unsafe conditions with your server. As each machine was designed and built, required safety items were installed to protect users and service technicians from injury.

Important: Electrical grounding of the server is required for operator safety and correct system function. Proper grounding of the electrical outlet can be verified by a certified electrician.

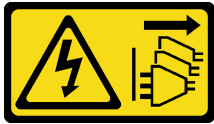

Make sure all power cords are disconnected from the system when reading the following step in this manual: *“Turn off the server and peripheral devices and disconnect the power cords and all external cables.”*

CAUTION:

This equipment must be installed by trained service personnel, as defined by the NEC and IEC 60950-1, Second Edition, the standard for Safety of Information Technology Equipment. Lenovo assumes you are qualified in the servicing of equipment and trained in recognizing hazards in products with hazardous energy levels.

Use the following checklist to verify that there are no potentially unsafe conditions:

1. Make sure that the power is off and the power cord is disconnected.
2. Check the power cord.
 - Make sure that the third-wire ground connector is in good condition. Use a meter to measure third-wire ground continuity for 0.1 ohm or less between the external ground pin and the frame ground.
 - Make sure that the power cord is the correct type.

To view the power cords that are available for the server:

- a. Go to:

<http://lesc.lenovo.com>

- b. In the Customize a Model pane:
 - 1) Click **Select Options/Parts for a Model**.
 - 2) Enter the machine type and model for your server.
- c. Click the Power tab to see all line cords.
 - Make sure that the insulation is not frayed or worn.
3. Check for any obvious non-Lenovo alterations. Use good judgment as to the safety of any non-Lenovo alterations.
4. Check inside the server for any obvious unsafe conditions, such as metal filings, contamination, water or other liquid, or signs of fire or smoke damage.
5. Check for worn, frayed, or pinched cables.
6. Make sure that the power-supply cover fasteners (screws or rivets) have not been removed or tampered with.

Chapter 1. Introduction

The ThinkSystem ST50 server is a 4U tower server designed for performance and expansion for various IT workloads. With the modular design, the server is flexible to be customized for maximum storage capacity or high storage density with selectable input/output options and tiered system management.

Performance, ease of use, reliability, and expansion capabilities were key considerations in the design of the server. These design features make it possible for you to customize the system hardware to meet your needs today and provide flexible expansion capabilities for the future.

The server comes with a limited warranty. For details about the warranty, see:

<https://datacentersupport.lenovo.com/documents/ht100742>

For details about your specific warranty, see:

<http://datacentersupport.lenovo.com/warrantylookup>

Identifying your server

When you contact Lenovo for help, the machine type and serial number information helps support technicians to identify your server and provide faster service.

The machine type and serial number are on the ID label on the front of the server.

The following illustration shows the location of the ID label.

Note: The illustrations in this document might differ slightly from your server.

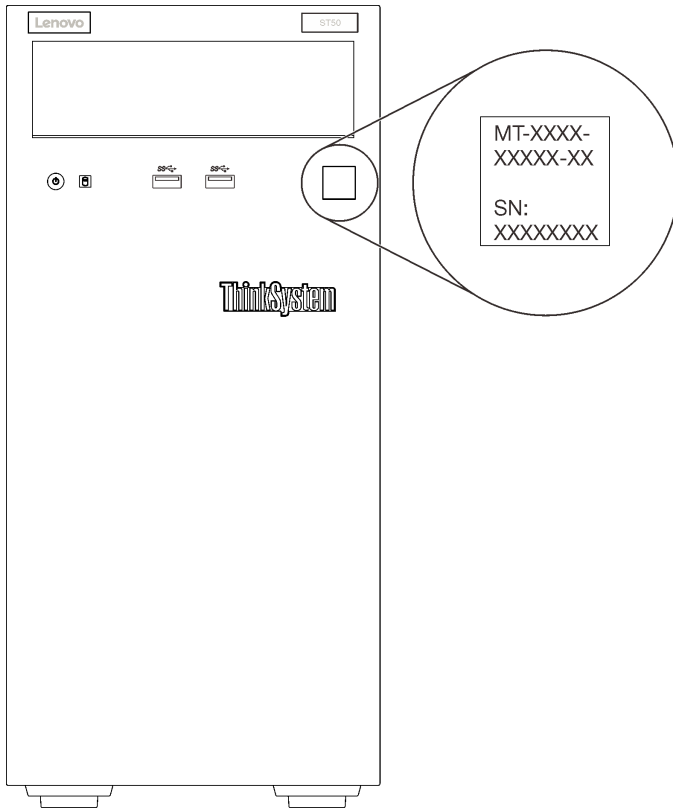

Figure 1. Location of the ID label

Quick response code

The system service label, which is on the inside of the server cover, provides a quick response (QR) code for mobile access to service information. Scan the QR code with a mobile device and a QR code reader application to get quick access to the Lenovo Service web site for this server. The Lenovo Service web site provides additional information for parts installation and replacement videos, and error codes for server support.

The following illustration shows the QR code.



Figure 2. QR code

Server form factor

The ThinkSystem ST50 server is designed to support both tower and rack form factors.

You can change the server from tower form factor to rack form factor by installing the tower-to-rack conversion kit. For instructions on how to install the tower-to-rack conversion kit, refer to the documentation that comes with the conversion kit.

Specifications

The following information is a summary of the features and specifications of the server. Depending on the model, some features might not be available, or some specifications might not apply.

Table 1. Specifications, Type 7Y48 and 7Y49

Specification	Description
Dimension	4U server <ul style="list-style-type: none"> • Height: 375 mm (14.76 inches) • Width: 175 mm (6.89 inches) • Depth: 407 mm (16.02 inches)
Weight (depending on the configuration)	<ul style="list-style-type: none"> • Maximum: 11.2 kg (24.69 lbs)
Processor	One LGA 1151 processor socket that supports the following Intel processors scalable up to six cores with integrated graphic output: <ul style="list-style-type: none"> • Xeon E3 • Core i3 • Pentium Gold • Celeron G For a list of supported processors, see: http://datacentersupport.lenovo.com
Memory	<ul style="list-style-type: none"> • Minimum: 8 GB • Maximum: 64 GB • DIMM types: <ul style="list-style-type: none"> – PC4-19200 (single-rank, dual-rank), 2400 MT/s, error correcting code (ECC), double-data-rate 4 (DDR4) registered DIMM (RDIMM) – PC4-21300 (single-rank, dual-rank), 2666 MT/s, error correcting code (ECC), double-data-rate 4 (DDR4) registered DIMM (RDIMM) • Slots: four DIMM slots, two-way interleaved
Storage expansion	Four drive bays and one optional USB dual SD card adapter are available for storage expansion and support the following types of drives: <ul style="list-style-type: none"> • Bay 1 to 3 support the following: <ul style="list-style-type: none"> – 3.5-inch hard-disk or solid-state drives – 2.5-inch hard-disk or solid-state drives (in 3.5 to 2.5-inch drive bay adapter) • Bay 4 supports the following: <ul style="list-style-type: none"> – One half-height optical disk drive – One LTO/RDX tape drive <p>Note: Before installing LTO tape drive, make sure to purchase the corresponding optional tape drive cable kit.</p> <ul style="list-style-type: none"> – One drive bay adapter for hard-disk/solid-state drive – One drive bay adapter for hard-disk/solid-state drive and slim optical drive • USB dual SD card adapter supports two SD card with the following capacities: <ul style="list-style-type: none"> – 32 GB – 64 GB <p>Note: The dual SD card adapter does not support hot-swap. Make sure to power off the server before installing or removing this adapter.</p>
Expansion slots	Three PCIe expansion slots are available: <ul style="list-style-type: none"> • Slot 1: PCI Express 3.0 x16 • Slot 2: PCI Express 3.0 x1 • Slot 3: PCI Express 3.0 x4

Table 1. Specifications, Type 7Y48 and 7Y49 (continued)

<p>Integrated functions</p>	<ul style="list-style-type: none"> • Six universal serial bus (USB) connectors <ul style="list-style-type: none"> – Two USB 3.1 Gen1 connectors on the front – Four USB connectors on the rear: <ul style="list-style-type: none"> – Two USB 3.1 Gen1 connectors – Two USB 2.0 connectors • One serial connector • One Line Out connector • Two DisplayPort connectors <p>Notes: Dual DisplayPort output will only work in the following conditions:</p> <ul style="list-style-type: none"> – Windows based OS: Intel VGA driver is installed. – Linux (Red Hat 7.5 OS): kernel/boot parameters "i915.alpha_support=1" is added.
<p>Network</p>	<p>One 1 Gbps RJ-45 Ethernet connector with Intel I219-LM</p>
<p>Systems management</p>	<p>Intel® Active Management Technology (AMT) 12</p> <p>Notes:</p> <ul style="list-style-type: none"> • Make sure the power is on when executing remote access and power policy setup. • Ignore the warning message “Unrecoverable PS/2 or USB keyboard failure,” because the system does not support PS/2 devices.
<p>RAID (depending on model)</p>	<p>The following options with RAID levels 0, 1, and 5 are available for this server. In addition, RAID level 10 is available when four drives are installed in the server.</p> <ul style="list-style-type: none"> • ThinkSystem 430-8i SAS/SATA 12Gb HBA • ThinkSystem RAID 530-8i PCIe 12Gb adapter • ThinkSystem RAID 730-8i 1GB cache PCIe 12Gb adapter • ThinkSystem RAID 930-8i 2GB flash PCIe 12Gb adapter • ThinkSystem 430-8e SAS/SATA 12Gb HBA • ThinkSystem RAID 930-8e 4GB flash PCIe 12Gb adapter <p>For a list of supported adapters, see: http://datacentersupport.lenovo.com</p> <p>Notes:</p> <ul style="list-style-type: none"> • Managing these optional RAID/HBA adapters in Setup Utility requires CSM to be disabled. Go to Startup, and click on CSM to disable it. After CSM is disabled, RAID/HBA ROM will be present in Devices tab in Setup Utility. • Refer to “Suspected RAID volume failure” on page 135 to resolve RAID volume failure in the case of ThinkSystem RAID adapter virtual driver failure.
<p>GPGPU adapter</p>	<p>The following option GPGPU adapter is available for this server.</p> <ul style="list-style-type: none"> • ThinkSystem NVIDIA Quadro P620 2GB PCIe Active GPU <p>Notes:</p> <ul style="list-style-type: none"> • This GPGPU adapter supports 4K resolution. • It is recommend to use certified display adapter cables.
<p>Fans</p>	<p>This server supports three fans:</p> <ul style="list-style-type: none"> • One on the front • One on the rear • One on the heat sink
<p>Electrical input</p>	<p>This server supports one of the following non-hot-swap, non-redundant power supplies:</p> <ul style="list-style-type: none"> • 250-watt Platinum <ul style="list-style-type: none"> – input power 115V or 230V ac • 400-watt Bronze <ul style="list-style-type: none"> – input power 115V or 230V ac

Table 1. Specifications, Type 7Y48 and 7Y49 (continued)

Minimal configuration	<ul style="list-style-type: none"> • One processor • One 8 GB ECC UDIMM in slot 1 • One power supply • One HDD/SSD • Power cord • Two system fans (front and rear)
Acoustical noise emissions	<ul style="list-style-type: none"> • Sound power level <ul style="list-style-type: none"> – Idle <ul style="list-style-type: none"> – minimum: 2.9 bels – typical: 3.4 bels – maximum: 4.6 bels – Operating <ul style="list-style-type: none"> – minimum: 2.9 bels – typical: 3.4 bels – maximum: 4.6 bels • Sound pressure level (tabletop) <ul style="list-style-type: none"> – Idle <ul style="list-style-type: none"> – minimum: 17.3 dBA – typical: 25.3 dBA – maximum: 36.7 dBA – Operating <ul style="list-style-type: none"> – minimum: 17.1 dBA – typical: 25.6 dBA – maximum: 37.2 dBA • Sound pressure level (floor) <ul style="list-style-type: none"> – Idle <ul style="list-style-type: none"> – minimum: 15.2 dBA – typical: 18.4 dBA – maximum: 29.3 dBA – Operating <ul style="list-style-type: none"> – minimum: 15.1 dBA – typical: 19.5 dBA – maximum: 29.5 dBA <p>Notes:</p> <ol style="list-style-type: none"> 1. These sound levels were measured in controlled acoustical environments according to procedures specified by ISO 7779 and are reported in accordance with ISO 9296. 2. The declared acoustic noise levels are based on specified configurations, which may change slightly depending on configuration/conditions.

Table 1. Specifications, Type 7Y48 and 7Y49 (continued)

Heat output	<p>Approximate heat output:</p> <ul style="list-style-type: none"> • Minimum configuration: 454 BTU , 133 W (in BTU per hour and watts) • Maximum configuration: 5118 BTU, 1500 W (in BTU per hour and watts)
Environment	<p>ThinkSystem ST50 complies with ASHRAE Class A2 specifications.</p> <ul style="list-style-type: none"> • Air temperature: <ul style="list-style-type: none"> – Operating <ul style="list-style-type: none"> – ASHARE Class A2: 10°C to 35°C (50°F to 95°F); the maximum ambient temperature decreases by 1°C for every 300 m (984 ft) increase in altitude above 900 m (2,953 ft). – Server off: -10°C to 60°C (14°F to 140°F) – Shipment/storage: -40°C to 60°C (-40°F to 140°F) • Maximum altitude: 3,050 m (10,000 ft) • Relative Humidity (non-condensing): <ul style="list-style-type: none"> – Operating <ul style="list-style-type: none"> – ASHRAE Class A2: 8% to 80%; maximum dew point: 21°C (70°F) – Shipment/storage: 8% to 90% • Particulate contamination <p>Attention: Airborne particulates and reactive gases acting alone or in combination with other environmental factors such as humidity or temperature might pose a risk to the server. For information about the limits for particulates and gases, see “Particulate contamination” on page 146.</p>

Update the firmware

Go to Lenovo Datacenter Support site for the latest firmware update package.

To update the firmware from a flash device, complete the following steps:

1. Go to <https://datacentersupport.lenovo.com/products/servers/thinksystem/st50?linkTrack=QR>.
2. Download the latest version of firmware update package.
3. Download the installation instructions, and follow the instructions to update the firmware.

Tech Tips

Lenovo continually updates the support website with the latest tips and techniques that you can use to solve issues that you might have with your server. These Tech Tips (also called retain tips or service bulletins) provide procedures to work around issues related to the operation of your server.

To find the Tech Tips available for your server:

1. Go to <http://datacentersupport.lenovo.com> and navigate to the support page for your server.
2. Click **How-tos & Solutions**.
Expand **Symptom** to choose a category for the type is problem that you are having.

Security advisories

Lenovo is committed to developing products and services that adhere to the highest security standards in order to protect our customers and their data. When potential vulnerabilities are reported, it is the responsibility of the Lenovo Product Security Incident Response Team (PSIRT) to investigate and provide information to our customers so they may put mitigation plans in place as we work toward providing solutions.

The list of current advisories is available at the following location:

Power on the server

After the server performs a short self-test (power status LED flashes quickly) when connected to input power, it enters a standby state (power status LED flashes once per second).

The server can be turned on (power LED on) in any of the following ways:

- You can press the power button.
- The server can restart automatically after a power interruption.

Note: If the boot screen lingers with the message of “System Security - The system has been tempered with,” it means the server cover is not properly installed. Remove and reinstall it (see “Server cover replacement” on page 115); then, restart the server.

For information about powering off the server, see “Power off the server” on page 8.

Power off the server

The server remains in a standby state when it is connected to a power source. To remove all power from the server (power-on LED off), you must disconnect all power cables.

To place the server in a standby state (power-on LED flashes once per second):

- Start an orderly shutdown using the operating system (if supported by your operating system).
- Press the power-on button to start an orderly shutdown (if supported by your operating system).
- Press and hold the power button for more than 4 seconds to force a shutdown.

Chapter 2. Server components

This section provides information that helps locate the server components.

Front view

Read this section to identify important components on the front of this server.

The following configurations are available for this server:

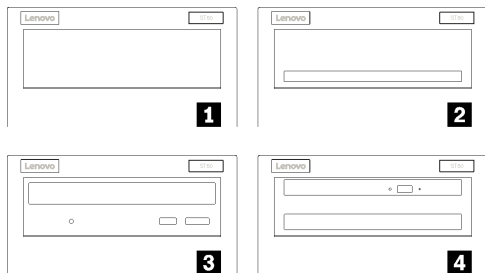

Figure 3. Front views of various configurations

Table 2. Front views of different configurations

1	One drive bay filler
2	One drive bay adapter for hard-disk/solid-state drive
3	One half height optical or LTO/RDX tape drive
4	One drive bay adapter for slim optical drive and hard-disk/solid-state drive

Front panel

Some crucial key controls, connectors, and LEDs are located on the front panel of the server.

The following illustration shows the controls, connectors, and LEDs on the front panel of the server.

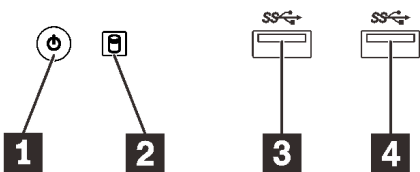

Figure 4. Components on the front panel

Table 3. Components on the front panel

1	Power button with power status LED (green)	3	USB 3.1 Gen1 connector
2	Drive activity LED (green)	4	USB 3.1 Gen1 connector

1 Power button with power status LED (green)

Press the power button to turn on the server, or hold it for several seconds to turn the server off when the server cannot be turned off in the operating system. The power status LED helps determine the current power status.

Status	Color	Description
Solid on	Green	The server is on and running.
Slow blinking (about one flash per second)	Green	The server is off and is ready to be powered on (standby state).
Off	None	There is no ac power applied to the server.

2 Drive activity LED (green)

This LED indicates the activity of the drives.

Table 4. Drive activity LED behavior

Status	Color	Description
Solid on	Green	The drives are active.
Off	None	The drives are not active.

Note: The drive activity LED only indicates the activities of drives that are connected to the SATA ports on the system board.

3 4 USB 3.1 Gen1 connectors

Available for a device that require USB 2.0 or 3.0 connection, such as a keyboard, a mouse, or a USB flash drive.

Rear view

Refer this section to identify important components on the rear of the server.

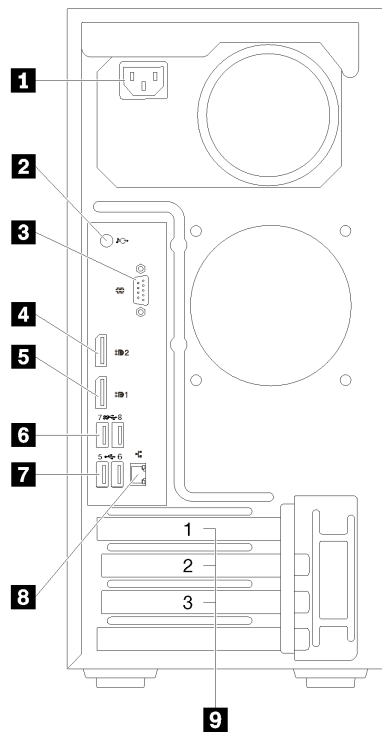

Figure 5. Rear view

Table 5. Rear view

1 Power supply	6 USB 3.1 Gen1 connectors (2)
2 Line Out connector	7 USB 2.0 connectors (2)
3 Serial connector	8 Ethernet connector
4 DisplayPort connector 2	9 PCIe slots (3)
5 DisplayPort connector 1	

1 Power supply unit

Connect the power cord to this component.

2 Line Out connector

Connect a audio device, such as speakers or earphones, to this connector.

Notes:

1. This connector only supports Windows client.
2. User may be aware of the low frequency noise via audio port in particular environments.
3. Excessive sound pressure from ear-/headphone can cause hearing damage.

3 Serial connector

Connect a 9-pin serial device to this connector.

4 5 DisplayPort connectors

Connect a DisplayPort-compatible video device, such as a monitor, to this connector.

6 7 USB connectors

Available for a device that require USB 2.0 or 3.0 connection, such as a keyboard, a mouse, or a USB flash drive.

8 Ethernet connector

Connect an Ethernet cable to this connector for a LAN . This connector comes with LED for status indication.

9 PCIe slots

This server comes with three PCIe slots on the system board. For detailed information about the PCIe slots, see “Specifications” on page 4.

System board components

The illustration in this section shows the component locations on the system board.

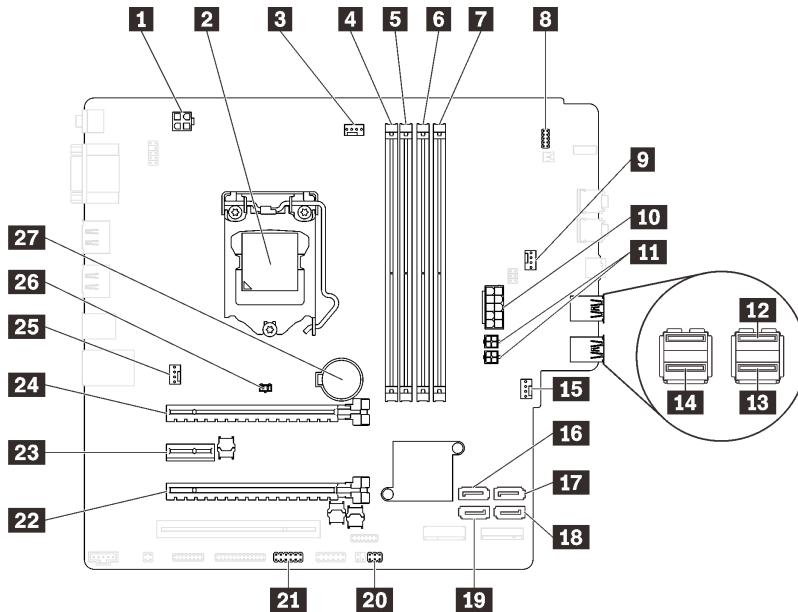

Figure 6. System board components

Table 6. Components on the system board

1 Processor power connector	15 Front fan power connector
2 Processor socket	16 SATA connector 3
3 Processor fan power connector	17 SATA connector 4
4 DIMM slot 1	18 SATA connector 2
5 DIMM slot 2	19 SATA connector 1
6 DIMM slot 3	20 Thermal sensor connector
7 DIMM slot 4	21 USB connector for dual SD card adapter
8 Front panel connector	22 PCIe slot 3
9 Drive bay adapter fan power connector	23 PCIe slot 2
10 System power connector	24 PCIe slot 1
11 SATA power connector	25 Rear fan power connector
12 Front panel USB connector	26 Intrusion switch connector
13 Front panel USB connector	27 3V CMOS battery (CR2032)
14 Slim optical drive USB connector	

System board jumpers

The following illustration shows the location of the jumpers on the server.

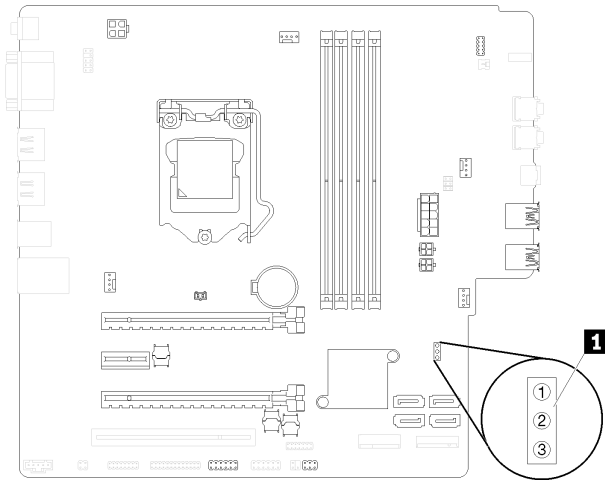

Figure 7. System board jumpers

Table 7. Jumper description

Jumper name	Jumper setting
1 CLR_CMOS	<ul style="list-style-type: none">Pin 1 and 2: defaultPin 1 and 3: clear CMOS

Important:

- Before you move the jumpers, turn off the server. Then, disconnect all power cords and external cables. Do not open your server or attempt any repair before reading and understanding the following information:
 - http://thinksystem.lenovofiles.com/help/topic/safety_documentation/pdf_files.html
 - “Handling static-sensitive devices” on page 33
- Any system-board switch or jumper block that is not shown in the illustrations in this document are reserved.

Dual SD card adapter module

Read this section to learn about the dual SD card adapter module.

Figure 8. Dual SD card adapter module

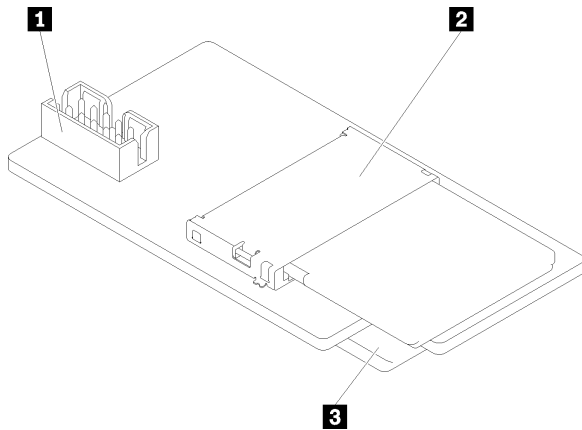

1 Connector for the system board	3 SD card slot (bottom)
2 SD card slot (top)	

Internal cable routing

Some of the components in the server come with internal cables meant for specific connectors.

Before connecting the cables, read the following guidelines carefully:

- Turn off the server before you connect or disconnect any internal cables.
- Refer to the documentation that comes with any external devices for additional cabling instructions.
- Make use of the identifiers printed on the cables to locate the proper connectors.
- Ensure that the cable is not pinched and does not cover any connectors or obstruct any components on the system board.

Note: Disengage all latches, release tabs, or locks on cable connectors when you disconnect cables from the system board. Failing to release them before removing the cables will damage the cable sockets on the system board, which are fragile. Any damage to the cable sockets might require replacing the system board.

Figure 9. Pressing the release tab to disengage the connector

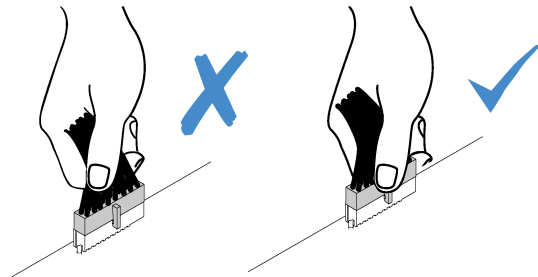

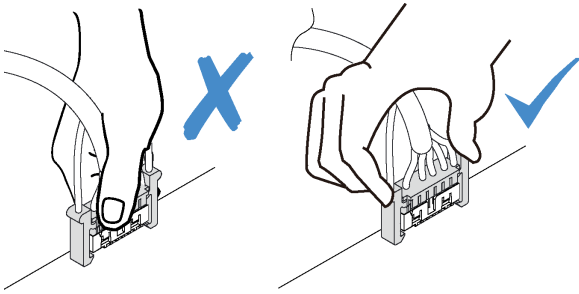

Figure 10. Squeezing the release tabs at both sides to disengage the connector

Cable routing for drive bay 1-3

Read this section to learn about cable routing for the drive in bay 1 to 3.

Drive bay 1

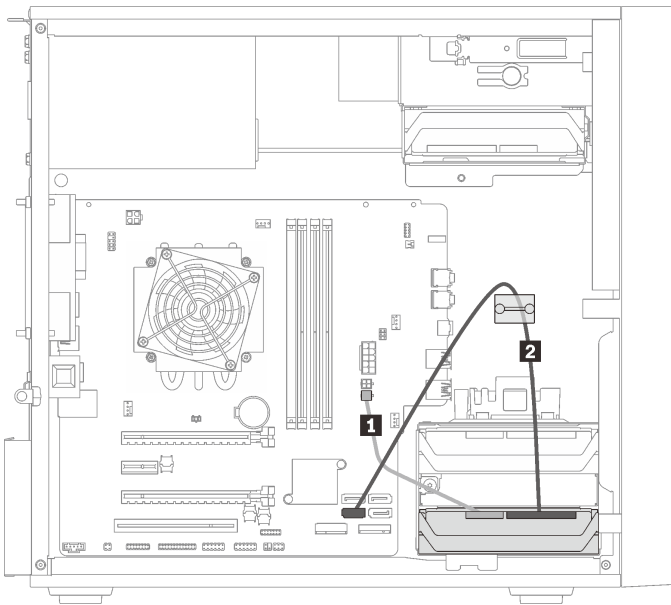

Figure 11. Cable routing for drive bay 1

Table 8. Cable routing for drive bay 1

1 Micro-fit to two 1X15P Y-splitter power cable, 450 mm	2 SATA 7-pin signal cable with latch, 420mm
---	---

Drive bay 2

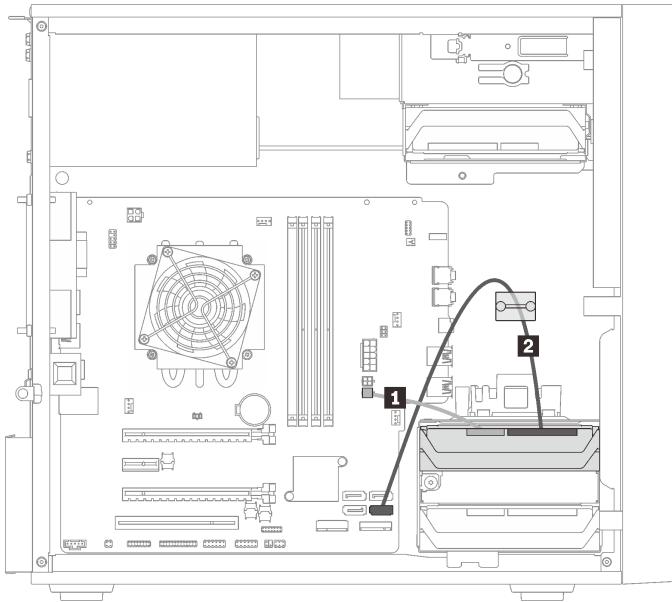

Figure 12. Cable routing for drive bay 2

Table 9. Cable routing for drive bay 2

1 Micro-fit to two 1X15P Y-splitter power cable, 450 mm	2 SATA 7-pin signal cable with latch, 420mm
--	--

Drive bay 3

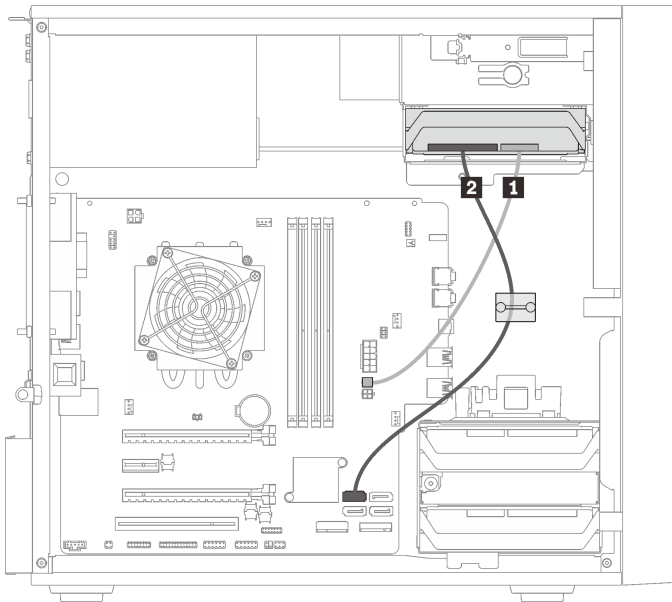

Figure 13. Cable routing for drive bay 3

Table 10. Cable routing for drive bay 3

1 Micro-fit to two 1X15P Y-splitter power cable, 450 mm	2 SATA 7-pin signal cable with latch, 420mm
--	--

Cable routing for drive bay 4

Read this section to learn about cable routing for the drive in bay 4.

Optical/tape drive

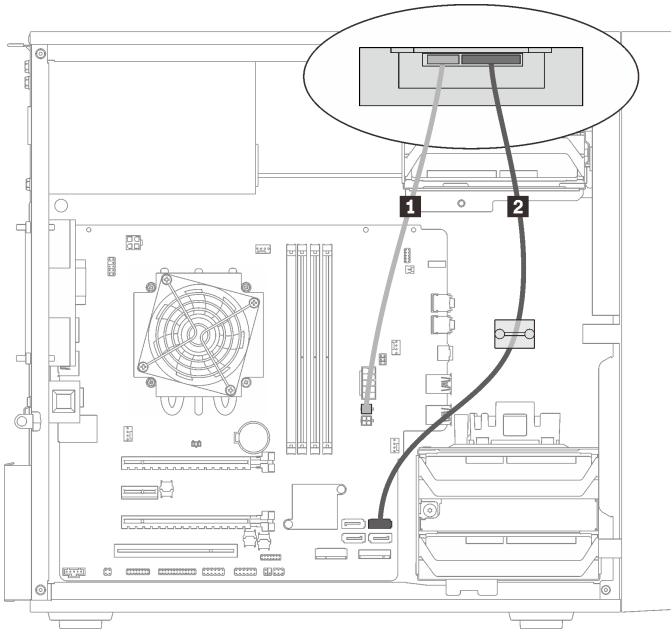

Figure 14. Cable routing for the optical/tape drive

Table 11. Cable routing for the optical/tape drive

1 Micro-fit to two 1X15P Y-splitter power cable, 450 mm	2 <ul style="list-style-type: none">• Optical drive: SATA signal cable for optical drive• Tape drive: SAS signal cable for tape drive
--	---

Drive bay adapter with hard-disk or solid-state drive

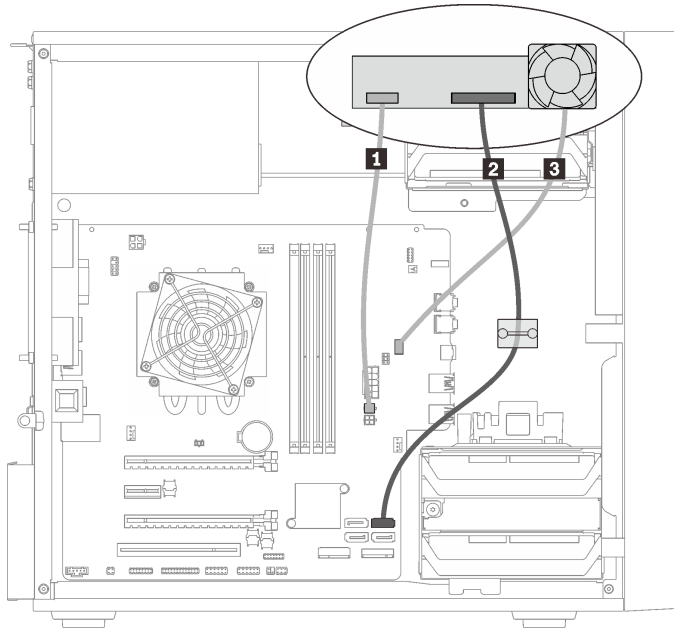

Figure 15. Cable routing for drive bay adapter with hard-disk or solid-state drive

Table 12. Cable routing for drive bay adapter with hard-disk or solid-state drive

1 Micro-fit to two 1X15P Y-splitter power cable, 450 mm	3 Drive bay adapter fan cable
2 SATA 7-pin signal cable with latch, 420mm	

Drive bay adapter with hard-disk or solid-state drive and slim optical drive

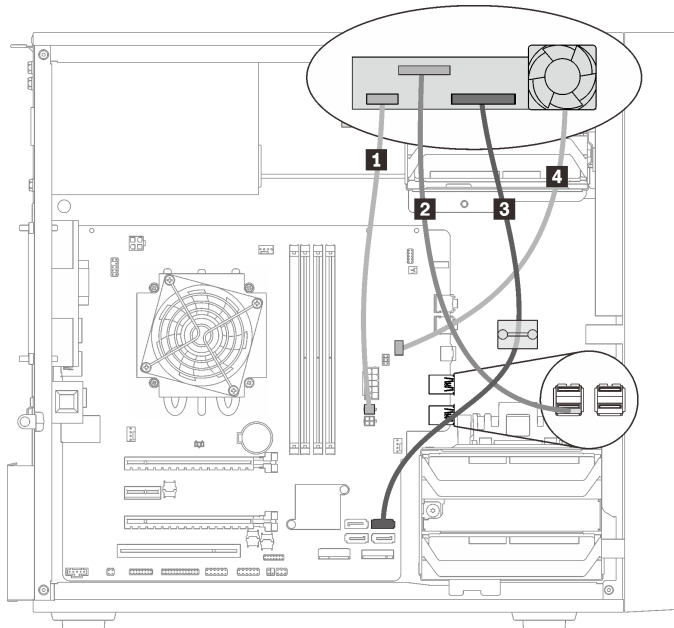

Figure 16. Cable routing for drive bay adapter with hard-disk or solid-state drive and slim optical drive

Table 13. Cable routing for drive bay adapter with hard-disk or solid-state drive and slim optical drive

1 Micro-fit to two 1X15P Y-splitter power cable, 450 mm	3 SATA 7-pin signal cable with latch, 420mm
2 Slim optical drive USB 2.0 Mini B cable	4 Drive bay adapter fan cable

Cable routing for the RAID adapter and drives

Read this section to learn about cable routing for the RAID adapter and drives.

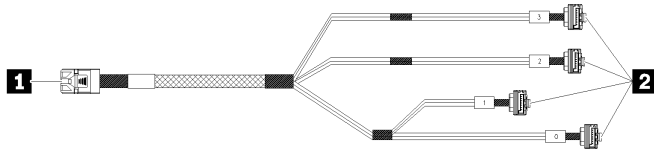

Figure 17. Mini SAS HD to 4 SATA 7-pin cable

Table 14. Mini SAS HD to 4 SATA 7-pin cable

1 Connector for the RAID adapter (connector C0)	2 Connectors for the drives
---	-----------------------------

Notes:

1. The RAID adapter can be installed in PCIe slot 1 or 3.
2. Make sure the signal cable go through the cable clip.

Cable routing for two drives with the RAID adapter

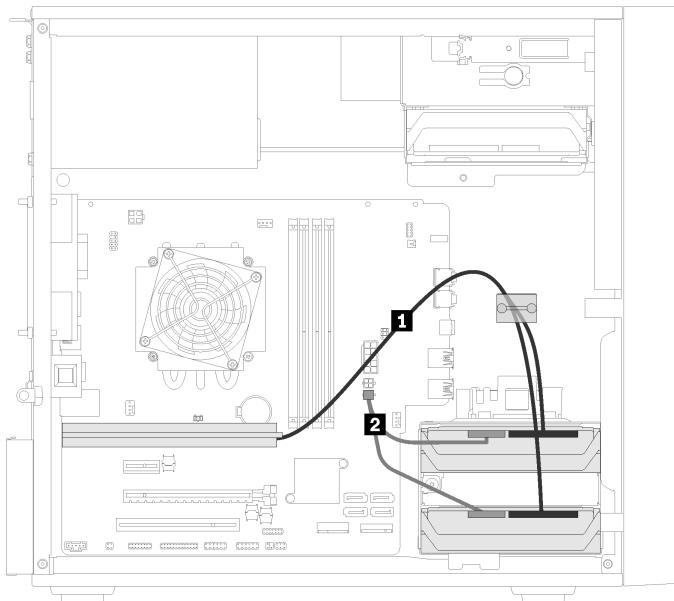

Figure 18. Cable routing for two drives with the RAID adapter

Table 15. Cable routing for two drives with the RAID adapter

1 Mini SAS HD to 4 SATA 7-pin cable	2 Micro-fit to two 1X15P Y-splitter power cable, 450 mm
-------------------------------------	---

Cable routing for three drives with the RAID adapter

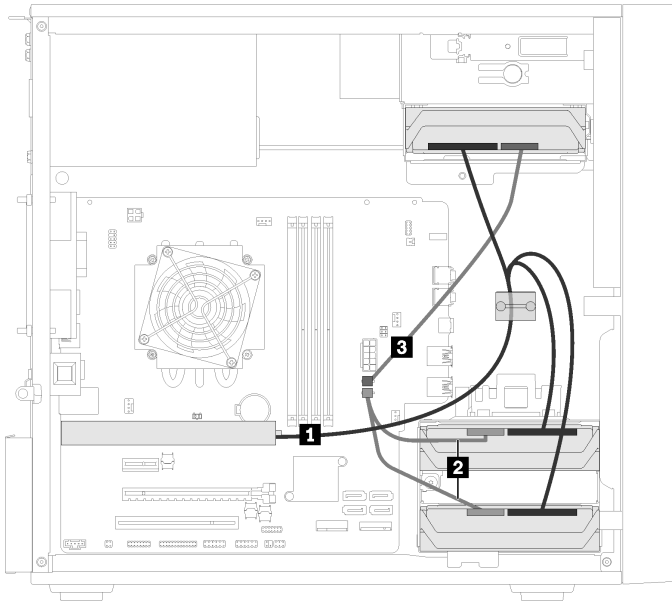

Figure 19. Cable routing for three drives with the RAID adapter

Table 16. Cable routing for three drives with the RAID adapter

1 Mini SAS HD to 4 SATA 7-pin cable	2 3 Micro-fit to two 1X15P Y-splitter power cable, 450 mm
--	---

Cable routing for four drives with the RAID adapter

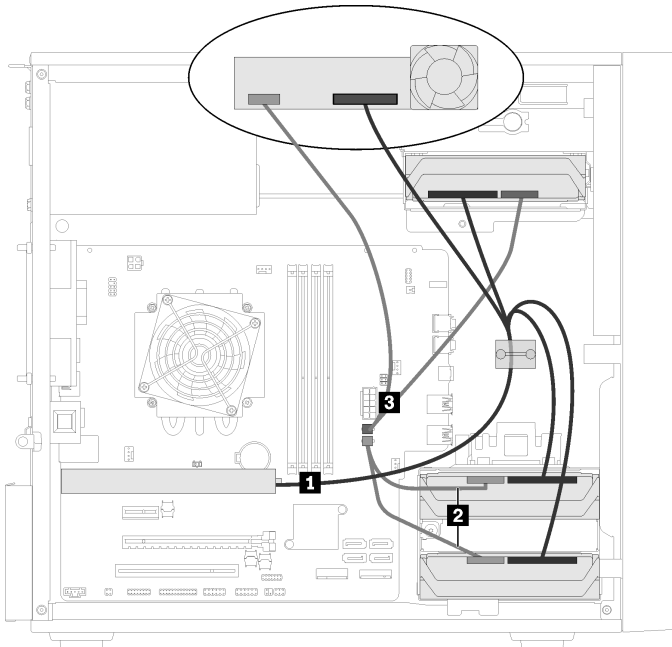

Figure 20. Cable routing for four drives with the RAID adapter

Table 17. Cable routing for four drives with the RAID adapter

1 Mini SAS HD to 4 SATA 7-pin cable	2 3 Micro-fit to two 1X15P Y-splitter power cable, 450 mm
--	---

Cable routing for the power supply unit

Read this section to learn about cable routing for the thermal sensor.

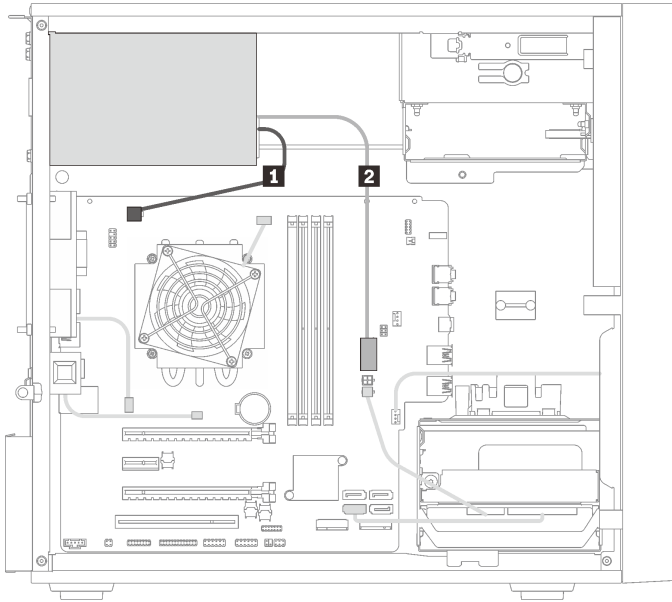

Figure 21. Cable routing for the power supply unit

Table 18. Cable routing for the power supply unit

1 Micro-fit to 1X15P and 1X4P Y-splitter power cable (4-pin SATA connector for processor power)	2 Micro-fit to 1X15P and 1X4P Y-splitter power cable (15-pin connector for system power)
---	--

Note: **1** and **2** are parts of the same Y-splitter cable.

Cable routing for the fans

Read this section to learn about cable routing for the fans.

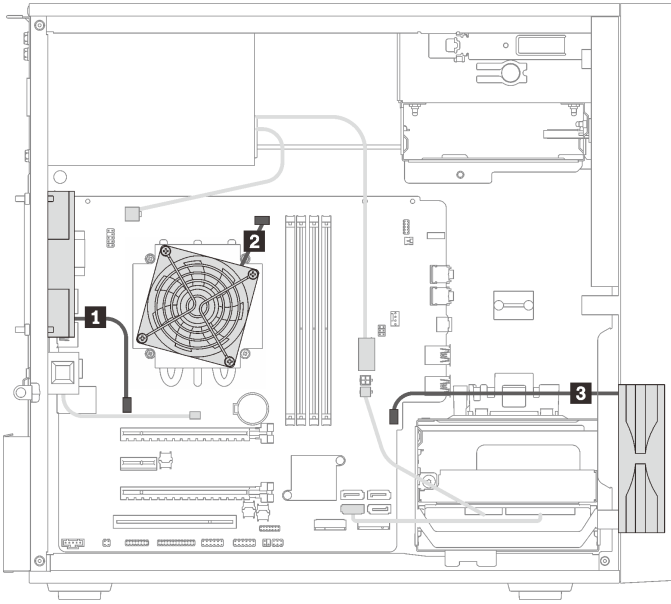

Figure 22. Cable routing for the fans

Table 19. Cable routing for drive bay 1

1 Rear fan cable	2 Front fan cable
2 Heat sink fan cable	

Cable routing for the front panel

Read this section to learn about cable routing for the front panel.

Drive bay 1

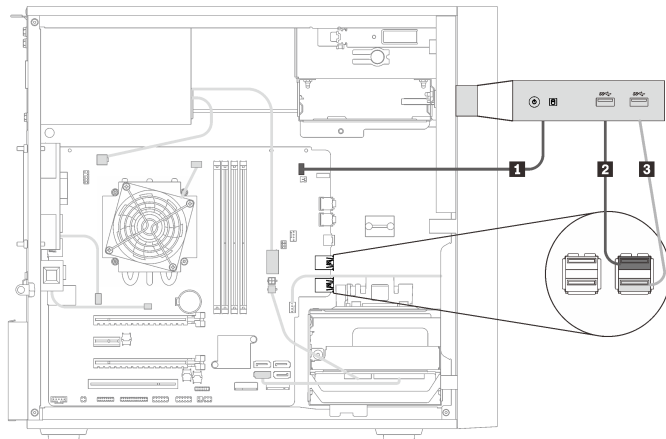

Figure 23. Cable routing for drive bay 1

Table 20. Cable routing for drive bay 1

1 Front panel cable	3 Front panel USB cable
2 Front panel USB cable	

Cable routing for the thermal sensor

Read this section to learn about cable routing for the thermal sensor.

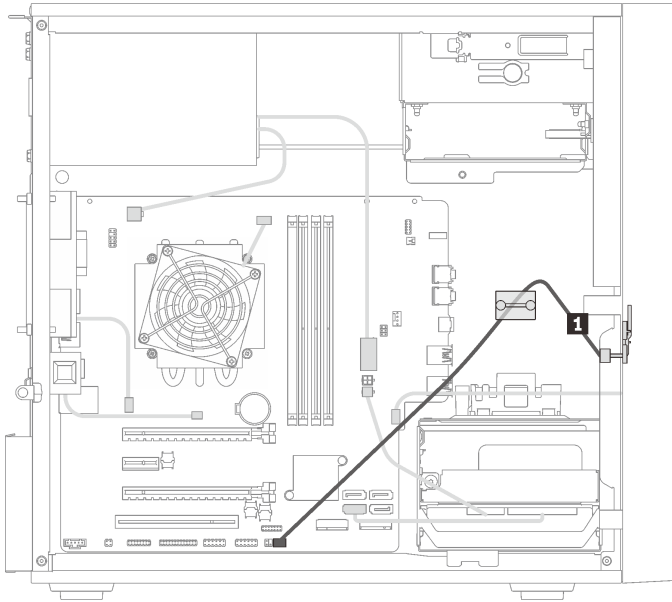

Figure 24. Cable routing for the thermal sensor

Table 21. Cable routing for the thermal sensor

1 Thermal sensor cable, 6-pin 460 mm

Note: Make sure the thermal sensor cable is routed through the cable clip.

Parts list

Use the parts list to identify each of the components that are available for your server.

Note: Depending on the model, your server might look slightly different from the illustration.

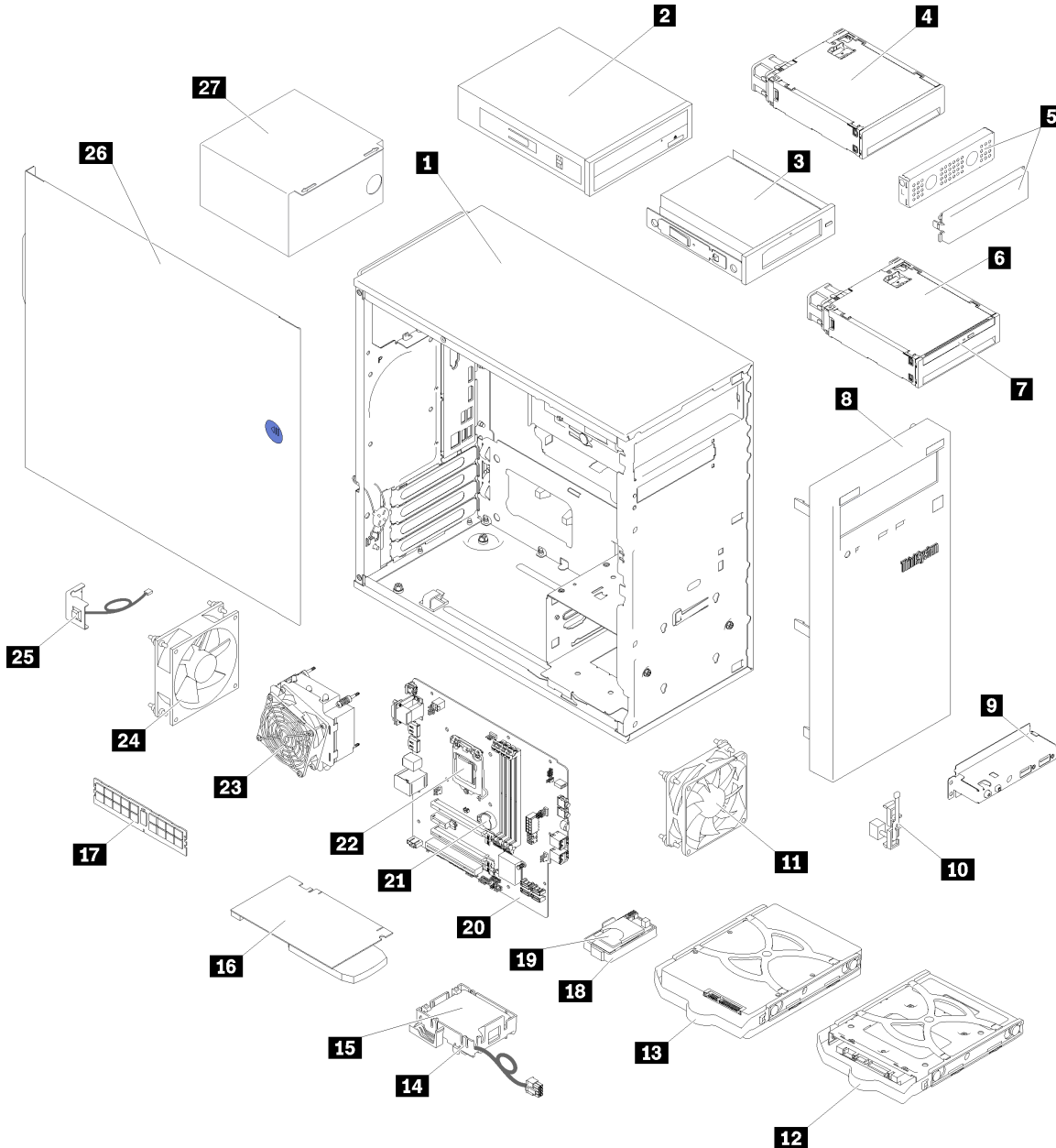

Figure 25. Server components

The parts listed in the following table are identified as one of the following:

- **Tier 1 customer replaceable unit (CRU):** Replacement of Tier 1 CRUs is your responsibility. If Lenovo installs a Tier 1 CRU at your request with no service agreement, you will be charged for the installation.
- **Tier 2 customer replaceable unit:** You may install a Tier 2 CRU yourself or request Lenovo to install it, at no additional charge, under the type of warranty service that is designated for your server.

- **Field replaceable unit (FRU):** FRUs must be installed only by trained service technicians.
- **Consumable and Structural parts:** Purchase and replacement of consumable and structural parts is your responsibility. If Lenovo acquires or installs a structural component at your request, you will be charged for the service.

Table 22. Parts listing

Index	Description	Tier 1 CRU	Tier 2 CRU	FRU	Consumable and Structural parts
For more information about ordering the parts shown in Figure 25 “Server components” on page 26: http://datacentersupport.lenovo.com/us/en/products/servers/thinksystem/st50/7y48/parts					
1	Chassis				√
2	Optical drive		√		
3	LTO/RDX tape drive	√			
4	Drive bay adapter for hard-disk/solid-state drive		√		
5	Drive bay filler and metal shield		√		
6	Drive bay adapter for slim optical drive and hard-disk/solid-state drive		√		
7	Slim optical drive		√		
8	Front bezel		√		
9	Front panel		√		
10	Thermal sensor		√		
11	Front fan		√		
12	2.5-inch simple-swap drive in the retainer		√		
13	3.5-inch simple-swap drive in the retainer		√		
14	Flash power module retainer		√		
15	Flash power module		√		
16	PCIe adapter		√		
17	DIMM	√			
18	Dual SD card adapter		√		
19	SD card		√		
20	System board			√	
21	CMOS battery	√			
22	Processor			√	
23	Heat sink and fan module			√	
24	Rear fan		√		

Table 22. Parts listing (continued)

Index	Description	Tier 1 CRU	Tier 2 CRU	FRU	Consumable and Structural parts
25	Intrusion switch		√		
26	Server cover				√
27	Power supply unit			√	

Power cords

Several power cords are available, depending on the country and region where the server is installed.

To view the power cords that are available for the server:

1. Go to:
<http://lesc.lenovo.com>
2. In the Customize a Model pane:
 - a. Click **Select Options/Parts for a Model**.
 - b. Enter the machine type and model for your server.
3. Click the Power tab to see all line cords.

Notes:

- For your safety, a power cord with a grounded attachment plug is provided to use with this product. To avoid electrical shock, always use the power cord and plug with a properly grounded outlet.
- Power cords for this product that are used in the United States and Canada are listed by Underwriter's Laboratories (UL) and certified by the Canadian Standards Association (CSA).
- For units intended to be operated at 115 volts: Use a UL-listed and CSA-certified cord set consisting of a minimum 18 AWG, Type SVT or SJT, three-conductor cord, a maximum of 15 feet in length and a parallel blade, grounding-type attachment plug rated 15 amperes, 125 volts.
- For units intended to be operated at 230 volts (U.S. use): Use a UL-listed and CSA-certified cord set consisting of a minimum 18 AWG, Type SVT or SJT, three-conductor cord, a maximum of 15 feet in length and a tandem blade, grounding-type attachment plug rated 15 amperes, 250 volts.
- For units intended to be operated at 230 volts (outside the U.S.): Use a cord set with a grounding-type attachment plug. The cord set should have the appropriate safety approvals for the country in which the equipment will be installed.
- Power cords for a specific country or region are usually available only in that country or region.

Chapter 3. Hardware replacement procedures

This section provides installation and removal procedures for all serviceable system components. Each component replacement procedure references any tasks that need to be performed to gain access to the component being replaced.

For more information about ordering parts:

1. Go to <http://datacentersupport.lenovo.com> and navigate to the support page for your server.
2. Click **Service Parts**.
3. Enter the serial number to view a listing of parts for your server.

Note: If you replace a part, such as an adapter, that contains firmware, you might also need to update the firmware for that part.

Installation guidelines

Before installing components in your server, read the installation guidelines.

Before installing optional devices, read the following notices carefully:

Attention: Prevent exposure to static electricity, which might lead to system halt and loss of data, by keeping static-sensitive components in their static-protective packages until installation, and handling these devices with an electrostatic-discharge wrist strap or other grounding system.

- Read the safety information and guidelines to ensure that you work safely.
 - A complete list of safety information for all products is available at: http://thinksystem.lenovofiles.com/help/topic/safety_documentation/pdf_files.html
 - “Handling static-sensitive devices” on page 33
- Make sure the components you are installing are supported by the server. For a list of supported optional components for the server, see <http://www.lenovo.com/us/en/serverproven/>.
- When you install a new server, download and apply the latest firmware. This will help ensure that any known issues are addressed, and that your server is ready to work with optimal performance. Go to [ThinkSystem ST50 Drivers and Software](#) to download firmware updates for your server.

Important: Some cluster solutions require specific code levels or coordinated code updates. If the component is part of a cluster solution, verify that the latest level of code is supported for the cluster solution before you update the code.

- It is good practice to make sure that the server is working correctly before you install an optional component.
- Keep the working area clean, and place removed components on a flat and smooth surface that does not shake or tilt.
- Do not attempt to lift an object that might be too heavy for you. If you have to lift a heavy object, read the following precautions carefully:
 - Make sure that you can stand steadily without slipping.
 - Distribute the weight of the object equally between your feet.
 - Use a slow lifting force. Never move suddenly or twist when you lift a heavy object.
 - To avoid straining the muscles in your back, lift by standing or by pushing up with your leg muscles.

- Make sure that you have an adequate number of properly grounded electrical outlets for the server, monitor, and other devices.
- Back up all important data before you make changes related to the disk drives.
- Have a small flat-blade screwdriver, a small Phillips screwdriver, and a T8 torx screwdriver available.
- You do not have to turn off the server to remove or install hot-swap power supplies or hot-plug USB devices. However, you must turn off the server before you perform any steps that involve removing or installing adapter cables, and you must disconnect the power source from the server before you perform any steps that involve removing or installing a DIMM.
- Blue on a component indicates touch points, where you can grip to remove a component from or install it in the server, open or close a latch, and so on.
- Orange on a component or an orange label on or near a component indicates that the component can be hot-swapped if the server and operating system support hot-swap capability, which means that you can remove or install the component while the server is still running. (Orange can also indicate touch points on hot-swap components.) See the instructions for removing or installing a specific hot-swap component for any additional procedures that you might have to perform before you remove or install the component.
- The Red strip on the drives, adjacent to the release latch, indicates that the drive can be hot-swapped if the server and operating system support hot-swap capability. This means that you can remove or install the drive while the server is still running.

Note: See the system specific instructions for removing or installing a hot-swap drive for any additional procedures that you might need to perform before you remove or install the drive.

- After finishing working on the server, make sure you reinstall all safety shields, guards, labels, and ground wires.

System reliability guidelines

Review the system reliability guidelines to ensure proper system cooling and reliability.

Make sure the following requirements are met:

- When the server comes with redundant power, a power supply must be installed in each power-supply bay.
- Adequate space around the server must be spared to allow server cooling system to work properly. Leave approximately 50 mm (2.0 in.) of open space around the front and rear of the server. Do not place any object in front of the fans.
- For proper cooling and airflow, refit the server cover before you turn the power on. Do not operate the server for more than 30 minutes with the server cover removed, for it might damage server components.
- Cabling instructions that come with optional components must be followed.
- A failed fan must be replaced within 48 hours since malfunction.
- A removed hot-swap drive must be replaced within two minutes after removal.
- A removed hot-swap power supply must be replaced within two minutes after removal.
- Every air baffle that comes with the server must be installed when the server starts (some servers might come with more than one air baffle). Operating the server with a missing air baffle might damage the processor.
- All processor sockets must contain either a socket cover or a processor with heat sink.
- When more than one processor is installed, fan population rules for each server must be strictly followed.

Handling static-sensitive devices

Review these guidelines before you handle static-sensitive devices to reduce the possibility of damage from electrostatic discharge.

Attention: Prevent exposure to static electricity, which might lead to system halt and loss of data, by keeping static-sensitive components in their static-protective packages until installation, and handling these devices with an electrostatic-discharge wrist strap or other grounding system.



- Limit your movement to prevent building up static electricity around you.
- Take additional care when handling devices during cold weather, for heating would reduce indoor humidity and increase static electricity.
- Always use an electrostatic-discharge wrist strap or other grounding system.
- While the device is still in its static-protective package, touch it to an unpainted metal surface on the outside of the server for at least two seconds. This drains static electricity from the package and from your body.
- Remove the device from the package and install it directly into the server without putting it down. If it is necessary to put the device down, put it back into the static-protective package. Never place the device on the server or on any metal surface.
- When handling a device, carefully hold it by the edges or the frame.
- Do not touch solder joints, pins, or exposed circuitry.
- Keep the device from others' reach to prevent possible damages.

CMOS battery (CR2032) replacement

Follow this procedure to remove and install the CMOS battery (CR2032).

Remove the CMOS battery

Follow this procedure to remove the CMOS battery.

	“Read the installation Guidelines” on page 31		“Power off the server for this task” on page 8		“ATTENTION: Static Sensitive Device Ground package before opening” on page 33
---	--	---	---	--	--

S002

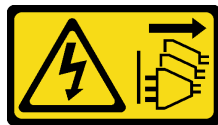

CAUTION:

The power control button on the device and the power switch on the power supply do not turn off the electrical current that is supplied to the device. The device also might have more than one power cord. To remove all electrical current from the device, ensure that all power cords are disconnected from the power source.

S004



CAUTION:

When replacing the lithium battery, use only Lenovo specified part number or an equivalent type battery recommended by the manufacturer. If your system has a module containing a lithium battery, replace it only with the same module type made by the same manufacturer. The battery contains lithium and can explode if not properly used, handled, or disposed of. *Do not:*

- Throw or immerse into water
- Heat to more than 100°C (212°F)
- Repair or disassemble

Dispose of the battery as required by local ordinances or regulations.

S005



CAUTION:

The battery is a lithium ion battery. To avoid possible explosion, do not burn the battery. Exchange it only with the approved part. Recycle or discard the battery as instructed by local regulations.

Before removing the CMOS battery:

1. Read the safety information and installation guidelines (see “Safety” on page iii and “Installation guidelines” on page 31).
2. Turn off the server and peripheral devices, and disconnect the power cords and all external cables (see “Power off the server” on page 8).
3. If the server is in a rack, remove it from the rack.
4. Remove any locking device that secures the server cover, such as a Kensington lock or a pad lock.
5. Remove the server cover (see “Remove the server cover” on page 115).

CAUTION:

The heat sinks and processor could be very hot. To avoid from burning yourself, wait for a few minutes after turning off the server before you remove the server cover.

6. Remove the PCIe adapter installed from slot 1 if necessary (see “Remove a PCIe adapter” on page 99).

To remove the CMOS battery, complete the following steps:

- Step 1. Locate the CMOS battery on the system board (see “System board components” on page 13).

Step 2. Gently press on the nub on the side of the CMOS battery as illustrated; then, pivot the battery away from the seat to remove it.

Attention: Avoid excessive force on the CMOS battery, as it might damage the socket on the system board and result in system board replacement.

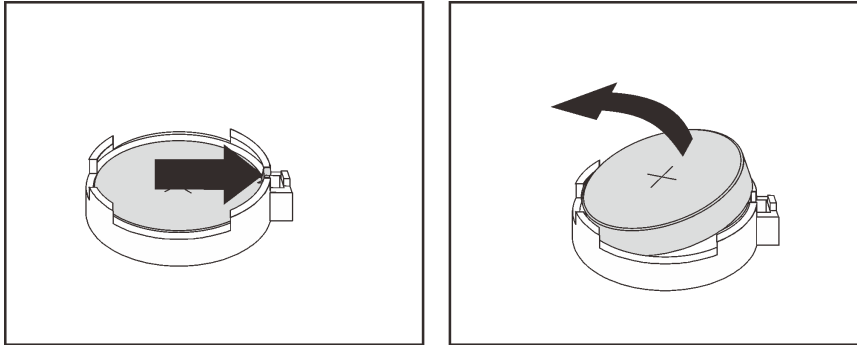

Figure 26. Removing the CMOS battery



After removing the CMOS battery:

1. Install a new CMOS battery. See “Install the CMOS battery” on page 35.
2. Dispose the CMOS battery as required by local ordinances or regulations.

Note: Make sure to install the CMOS battery before powering on the server. Otherwise, it might cause system abnormality.

Install the CMOS battery

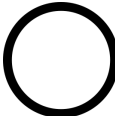
Follow this procedure to install the CMOS battery.

 <p>“Read the installation Guidelines” on page 31</p>	 <p>“Power off the server for this task” on page 8</p>	 <p>“ATTENTION: Static Sensitive Device Ground package before opening” on page 33</p>
--	---	---

Consider the following when replacing the CMOS battery in the server:

- When replacing the CMOS battery, you must replace it with another CMOS battery of the same type from the same manufacturer.
- After replacing the CMOS battery, make sure to reconfigure the server and reset system date and time.
- To avoid possible danger, make sure to read and follow the safety statements.
- Lenovo has designed this product with your safety in mind. The CMOS battery must be handled correctly to avoid possible danger. If you install the CMOS battery, do adhere to the following instructions.

Note: In the U. S., call 1-800-IBM-4333 for information about battery disposal.

- If you replace the original CMOS battery with a heavy-metal battery or a battery with heavy-metal components, be aware of the following environmental consideration. Batteries and accumulators that contain heavy metals must not be disposed of along with normal domestic waste. They should be taken back free of charge by for recycle or proper disposal by the manufacturer, distributor, or representatives.

S002



CAUTION:

The power control button on the device and the power switch on the power supply do not turn off the electrical current that is supplied to the device. The device also might have more than one power cord. To remove all electrical current from the device, ensure that all power cords are disconnected from the power source.

S004



CAUTION:

When replacing the lithium battery, use only Lenovo specified part number or an equivalent type battery recommended by the manufacturer. If your system has a module containing a lithium battery, replace it only with the same module type made by the same manufacturer. The battery contains lithium and can explode if not properly used, handled, or disposed of. *Do not:*

- Throw or immerse into water
- Heat to more than 100°C (212°F)
- Repair or disassemble

Dispose of the battery as required by local ordinances or regulations.

S005



CAUTION:

The battery is a lithium ion battery. To avoid possible explosion, do not burn the battery. Exchange it only with the approved part. Recycle or discard the battery as instructed by local regulations.

Before installing the CMOS battery:

1. Touch the static-protective package that contains the component to any unpainted metal surface on the server; then, remove it from the package and place it on a static-protective surface.

To install the CMOS battery, complete the following steps:

Step 1. Place the CMOS battery on top of the socket with the positive (+) symbol facing up, and press the battery into the seat until it clicks in place.

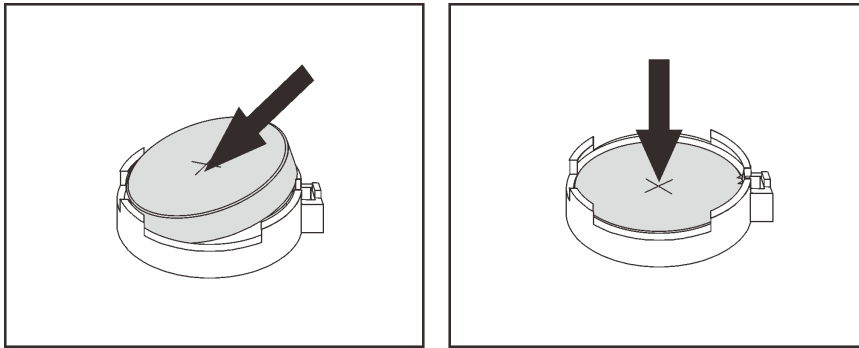

Figure 27. Installing the CMOS battery

After installing the CMOS battery:



1. If the PCIe adapter in slot 1 was removed, install it (see “Install a PCIe adapter” on page 102).
2. Proceed to complete the parts replacement (see “Complete the parts replacement” on page 125).
3. Reset date, time, and all the passwords.

DIMM replacement

Follow this procedure to remove and install a DIMM.

Remove a DIMM

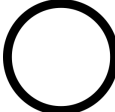
Follow this procedure to remove a DIMM.

	“Read the installation Guidelines” on page 31		“Power off the server for this task” on page 8		“ATTENTION: Static Sensitive Device Ground package before opening” on page 33
---	--	---	---	--	--

S002



CAUTION:

The power control button on the device and the power switch on the power supply do not turn off the electrical current that is supplied to the device. The device also might have more than one power cord. To remove all electrical current from the device, ensure that all power cords are disconnected from the power source.

Before removing a DIMM:

1. Read the safety information and installation guidelines (see “Safety” on page iii and “Installation guidelines” on page 31).
2. Turn off the server and peripheral devices, and disconnect the power cords and all external cables (see “Power off the server” on page 8).

3. If the server is in a rack, remove it from the rack.
4. Remove any locking device that secures the server cover, such as a Kensington lock or a pad lock.
5. Remove the server cover (see “Remove the server cover” on page 115).

CAUTION:

The heat sinks and processor could be very hot. To avoid from burning yourself, wait for a few minutes after turning off the server before you remove the server cover.

6. Remove the PCIe adapter installed from slot 1 if necessary (see “Remove a PCIe adapter” on page 99).

Attention: DIMMs are sensitive to static discharge and require special handling. In addition to the standard guidelines of “handling static-sensitive devices” on page 33:

- Always wear an electrostatic-discharge strap when removing or installing DIMMs. Electrostatic-discharge gloves can also be used.
- Keep each DIMM separated from one another. Do not stack DIMMs directly on top of each other during storage.
- Keep the gold DIMM connector contacts from touching anything.
- Handle DIMMs with care: never bend, twist, or drop a DIMM.

To remove a DIMM, complete the following steps:

- Step 1. Carefully open the retaining clips on both ends of the DIMM slot; then, gently lift the DIMM to remove it.

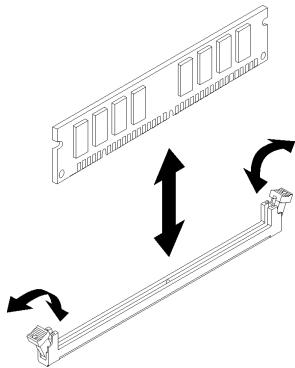

Figure 28. Removing the DIMM

After removing the DIMM:

1. Install a new DIMM if necessary (see “Install a DIMM” on page 40).
2. If you are instructed to return the defective component, package the part to prevent any shipping damage. Reuse the packaging of the new part that arrived, and follow all available packaging instructions.

DIMM installation rules

DIMMs must be installed in a specific order based on the memory configuration of the server.

The following illustration shows the location of the DIMM connectors on the system board.

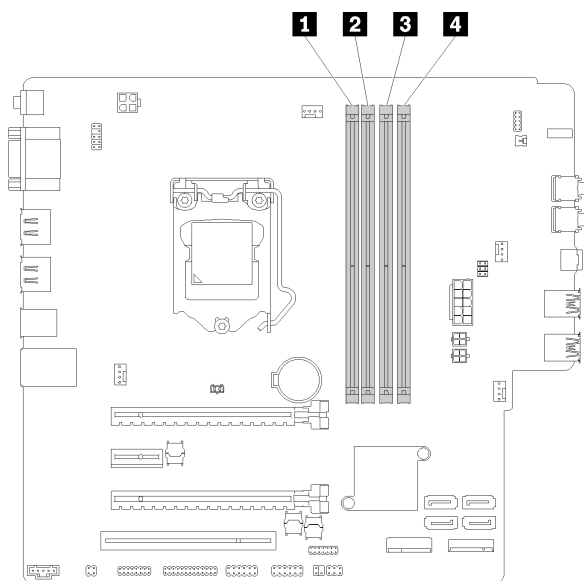

Table 23. DIMM slots on the system board

1 DIMM slot 1	3 DIMM slot 3
2 DIMM slot 2	4 DIMM slot 4

Figure 29. DIMM slots on the system board

For a list of supported DIMM options, see: <http://www.lenovo.com/us/en/serverproven/>

Notes: Make sure to adhere to the following rules:

- Do not mix ECC and non-ECC DIMMs.
- Do not mix DIMMs with different voltages.
- Do not mix low-voltage and regular UDIMMs.

This server supports independent mode only.

Independent mode

Independent mode provides high performance memory capability. You can populate all channels with no matching requirements. Individual channels can run at different DIMM timings, but all channels must run at the same interface frequency.

Notes:

- All the DIMMs to be installed should be of the same type and capacity.

The following table shows the DIMM population sequence for independent mode.

Table 24. Independent mode DIMM installation sequence



Total DIMMs	Slot 1	Slot 2	Slot 3	Slot 4
1	V			
2	V		V	

Table 24. Independent mode DIMM installation sequence (continued)

Total DIMMs	Slot 1	Slot 2	Slot 3	Slot 4
3	V	V	V	
4	V	V	V	V

Install a DIMM

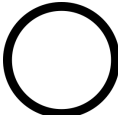
Follow this procedure to install a DIMM.

 <p>“Read the installation Guidelines” on page 31</p>	 <p>“Power off the server for this task” on page 8</p>	 <p>“ATTENTION: Static Sensitive Device Ground package before opening” on page 33</p>
--	---	---

S002



CAUTION:

The power control button on the device and the power switch on the power supply do not turn off the electrical current that is supplied to the device. The device also might have more than one power cord. To remove all electrical current from the device, ensure that all power cords are disconnected from the power source.

Before installing a DIMM:

1. Locate the DIMM slots and determine DIMM installation order based on “DIMM installation rules” on page 38.
2. Remove the PCIe adapter installed from slot 1 if necessary (see “Remove a PCIe adapter” on page 99).
3. Make sure that both retaining clips on the DIMM connector are in the open position. If not, press and open the retaining clip on both ends of the DIMM slot.

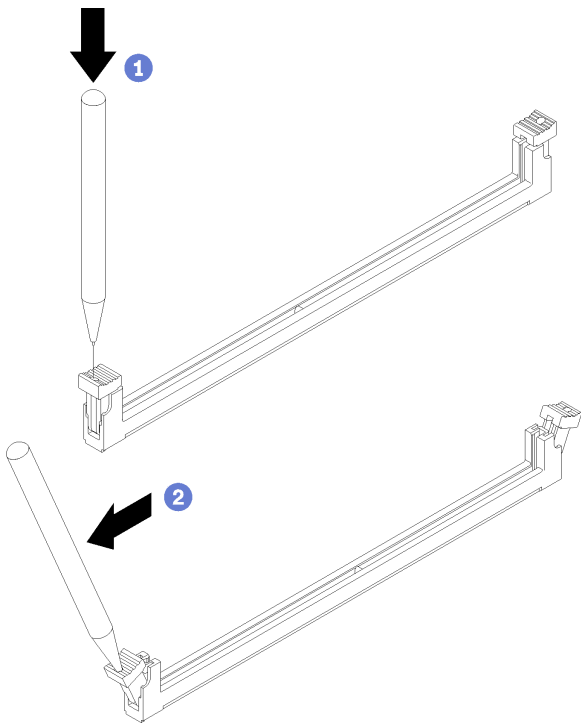

Figure 30. Opening the DIMM retaining clips

Note: In the case of space constraints, use a pointed tool to open the retaining clips. Place the tip of the tool in the recess on the top of the retaining clip; then, carefully pivot the retaining clip away from the center of the DIMM connector.

4. Touch the static-protective package that contains the component to any unpainted metal surface on the server; then, remove it from the package and place it on a static-protective surface.

Attention: DIMMs are sensitive to static discharge and require special handling. In addition to the standard guidelines of “handling static-sensitive devices” on page 33:

- Always wear an electrostatic-discharge strap when removing or installing DIMMs. Electrostatic-discharge gloves can also be used.
- Keep each DIMM separated from one another. Do not stack DIMMs directly on top of each other during storage.
- Keep the gold DIMM connector contacts from touching anything.
- Handle DIMMs with care: never bend, twist, or drop a DIMM.

To install a DIMM, complete the following steps:

- Step 1. Align the DIMM to the connector on the DIMM slot; then, press the DIMM straight into the slot with even pressure on both ends of the DIMM until the retaining clips snap into the locked position.

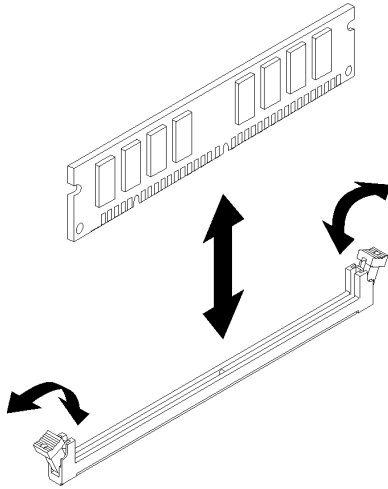

Figure 31. Installing a DIMM

Note: Make sure that the small tabs on the retaining clips engage the notches on the DIMM. If there is a gap between the DIMM and the retaining clips, it indicates that the DIMM has not been properly installed. Remove the DIMM and reinstall it.

After installing a DIMM:

1. Install other DIMMs if necessary.
2. If the PCIe adapter in slot 1 was removed, install it (see “Install a PCIe adapter” on page 102).
3. Proceed to complete the parts replacement (see “Complete the parts replacement” on page 125).
4. Reconfigure the DIMMs if necessary.

Drive replacement

Follow this procedure to remove and install a drive.

See the following section for location of the drive bays and types of drives supported.

Figure 32. Drive bays

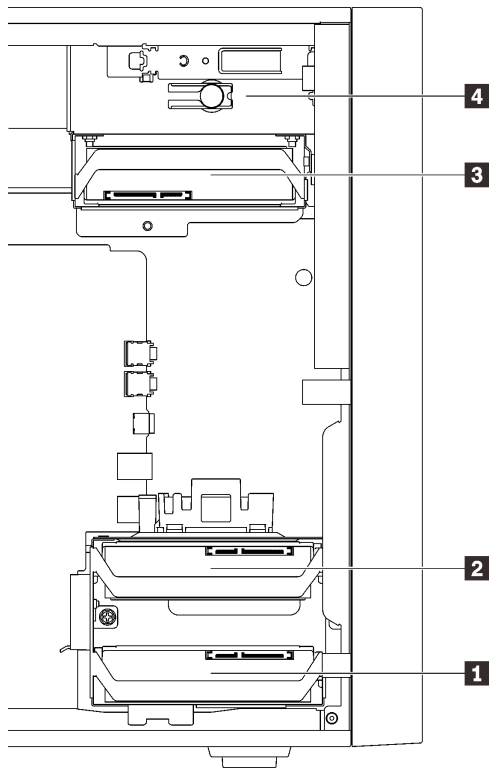

Table 25. Drive bays and types of drive supported

Drive bay	Types of drive supported
1 Bay 1	<ul style="list-style-type: none"> • 3.5-inch simple-swap drive • 2.5-inch simple-swap drive
2 Bay 2	
3 Bay 3	
4 Bay 4	<ul style="list-style-type: none"> • 5.25-inch drive bay filler • 5.25-inch optical drive • 5.25-inch RDX/LTO tape drive • 5.25-inch bay adapter for hard-disk/solid-state drive • 5.25-inch bay adapter for slim optical drive and hard-disk/solid-state drive

Simple-swap drive replacement (bay 1-3)

Follow this procedure to remove and install a simple-swap drive from and into bay 1 to 3.

This section only applies to drives to be removed and installed from and into bay 1 to 3. To remove or install a drive from or into bay 4, see “Remove a 5.25-inch drive bay adapter assembly” on page 58 and “Install a 5.25-inch drive bay adapter assembly” on page 62.

Remove a simple-swap drive (bay 1-3)

Follow this procedure to remove a simple-swap drive.

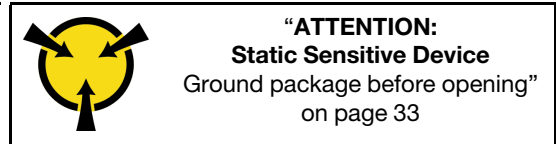
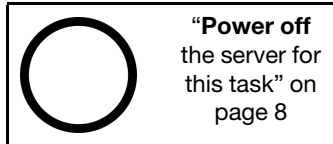

S002

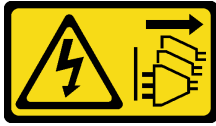

CAUTION:

The power control button on the device and the power switch on the power supply do not turn off the electrical current that is supplied to the device. The device also might have more than one power cord. To remove all electrical current from the device, ensure that all power cords are disconnected from the power source.

Before removing a simple-swap drive:

1. Read the safety information and installation guidelines (see “Safety” on page iii and “Installation guidelines” on page 31).
2. Turn off the server and peripheral devices, and disconnect the power cords and all external cables (see “Power off the server” on page 8).
3. If the server is in a rack, remove it from the rack.
4. Remove any locking device that secures the server cover, such as a Kensington lock or a pad lock.
5. Remove the server cover (see “Remove the server cover” on page 115).

CAUTION:

The heat sinks and processor could be very hot. To avoid from burning yourself, wait for a few minutes after turning off the server before you remove the server cover.

To remove a simple-swap drive, complete the following steps:

Step 1. Disconnect every cable from the drive assembly.

Step 2. Grasp the retainer handle, and slide the drive assembly out from the drive bay.

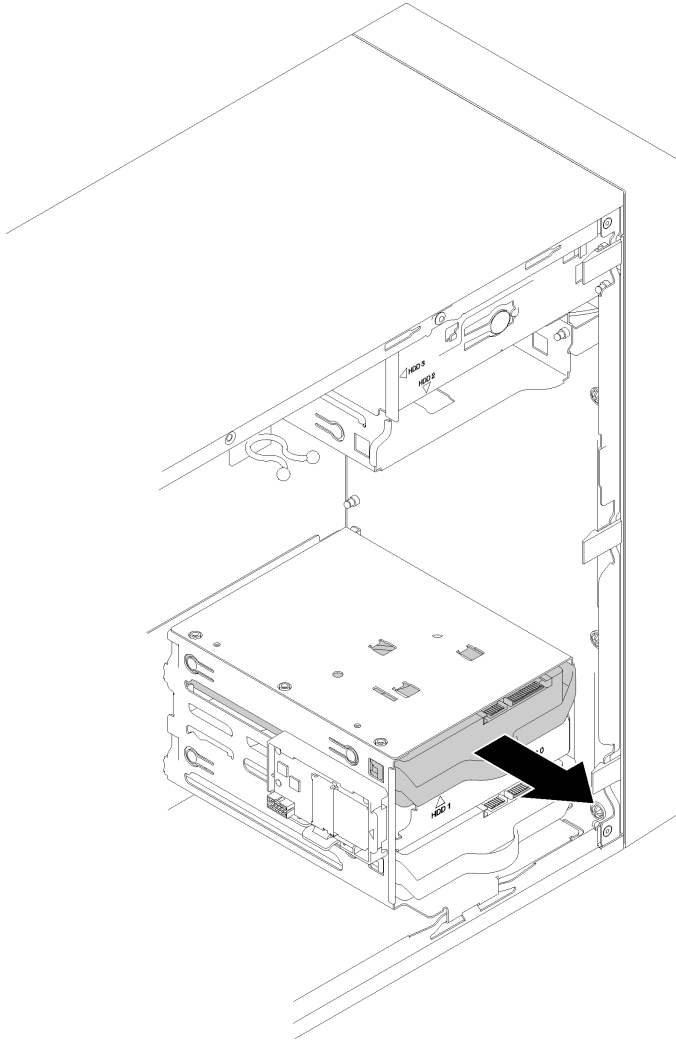

Figure 33. Removing a drive assembly from bay 2

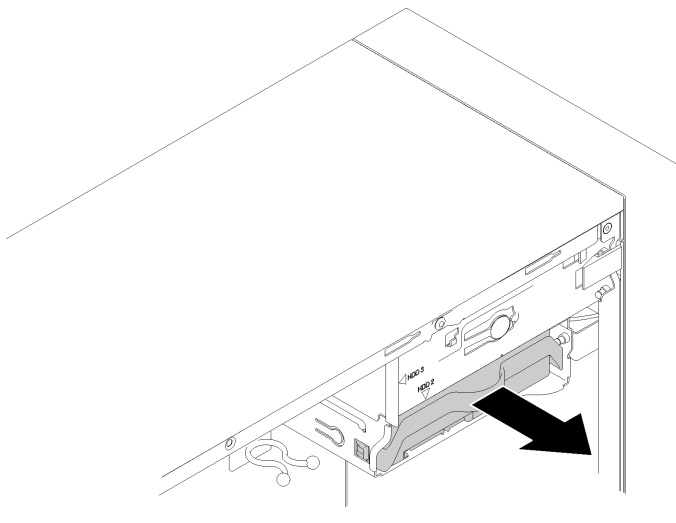

Figure 34. Removing a drive assembly from bay 3

Step 3. If necessary, remove the drive from the retainer.

3.5-inch drive

- a. Tear both sides of the retainer apart, and remove the drive.

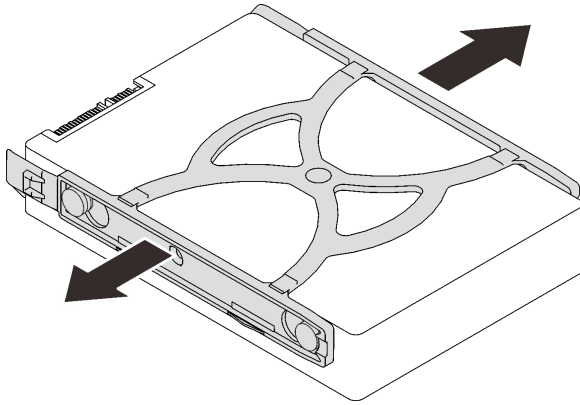

Figure 35. Removing a 3.5-inch drive from the retainer

2.5-inch drive

- a. Remove the four screws that secured the drive to the retainer, and remove the drive.

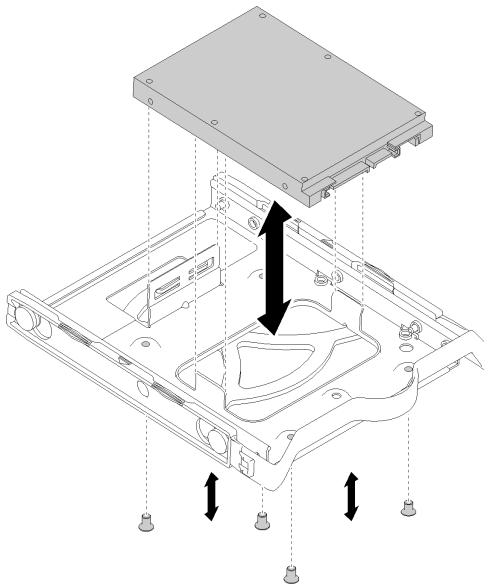

Figure 36. Removing a 2.5-inch drive from the retainer

After removing the simple-swap drive:

1. Install a new drive (see “Install a simple-swap drive (bay 1-3)” on page 47). Otherwise, install the screws to the retainer, and slide the retainer back into the drive bay for future use.
2. If you are instructed to return the defective component, package the part to prevent any shipping damage. Reuse the packaging of the new part that arrived, and follow all available packaging instructions.

Install a simple-swap drive (bay 1-3)

Follow this procedure to install a simple-swap drive.

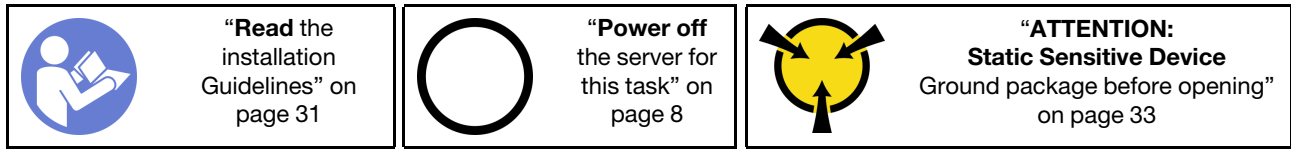

S002

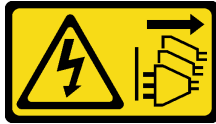

CAUTION:

The power control button on the device and the power switch on the power supply do not turn off the electrical current that is supplied to the device. The device also might have more than one power cord. To remove all electrical current from the device, ensure that all power cords are disconnected from the power source.

Before installing a simple-swap drive:

1. Make sure the type of drives to be installed is supported. Following are the types supported:

- 3.5-inch simple-swap drive
- 2.5-inch simple-swap drive

For a complete list of supported optional devices for the server, see:

<http://www.lenovo.com/us/en/serverproven/>

2. If there are more than one drives to be installed, determine installation order based on the following rules:

- Start with solid-state drives, and proceed with hard-disk drives.
- Start with the drive with the lowest capacity.
- Start with bay 1, proceed to bay 2, and 3.

Note: Drives of different types and different capacities are allowed to be installed in one server, but not in the same RAID array. The drives in a single RAID array must be the same type and the same capacity. See http://sysmgmt.lenovofiles.com/help/index.jsp?topic=%2F%2FLXPM%2FRAID_setup.html for more details.

To install a simple-swap drive, complete the following steps:

Step 1. Prepare the drive to be installed if necessary:

Note: To prevent from damaging the drive with static discharge, do not touch the circuit board on the bottom of the drive.

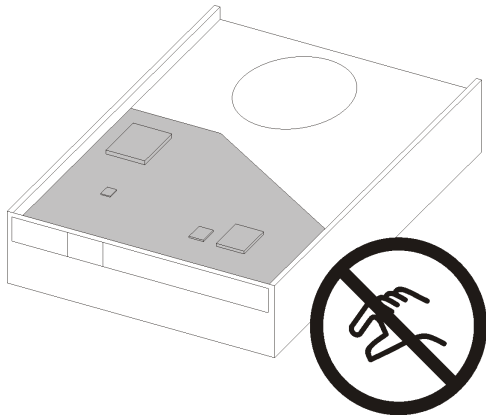

Figure 37. Circuit board on the drive

3.5-inch drive

- a. Slightly tear both sides of the retainer apart; then, fit the drive in the retainer.
- b. Align the four holes on the drive with the corresponding pins on the retainer, and lower the drive until it is secured in the retainer.

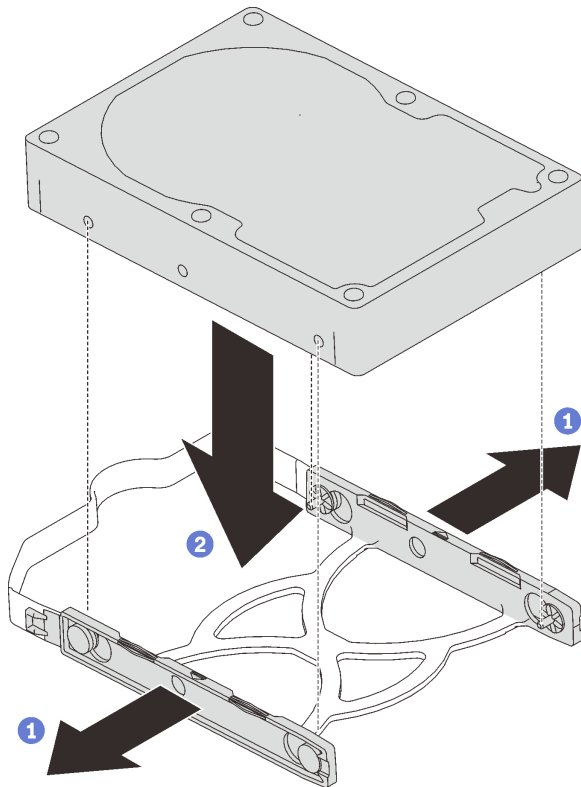

Figure 38. Installing a 3.5-inch drive into the retainer

2.5-inch drive

- a. Align the four screw holes on the retainer to those on the drive; then, secure the drive to the adapter with four screws.

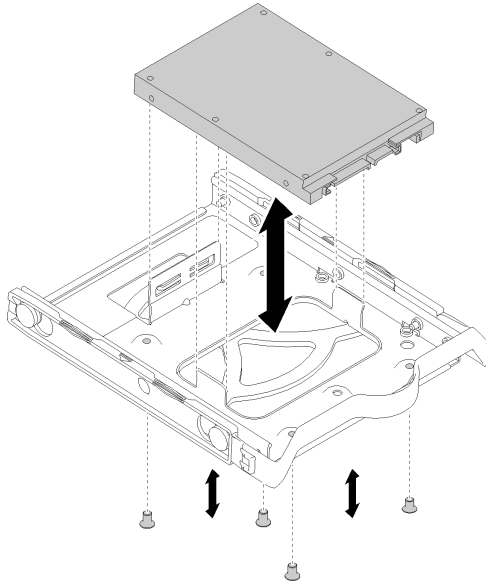

Figure 39. Installing a 2.5-inch drive into the retainer

Step 2. Install the drive assembly based on the drive number:

- Bay 1 and 2

Face the connectors up, and slide the drive assembly into the drive bay.

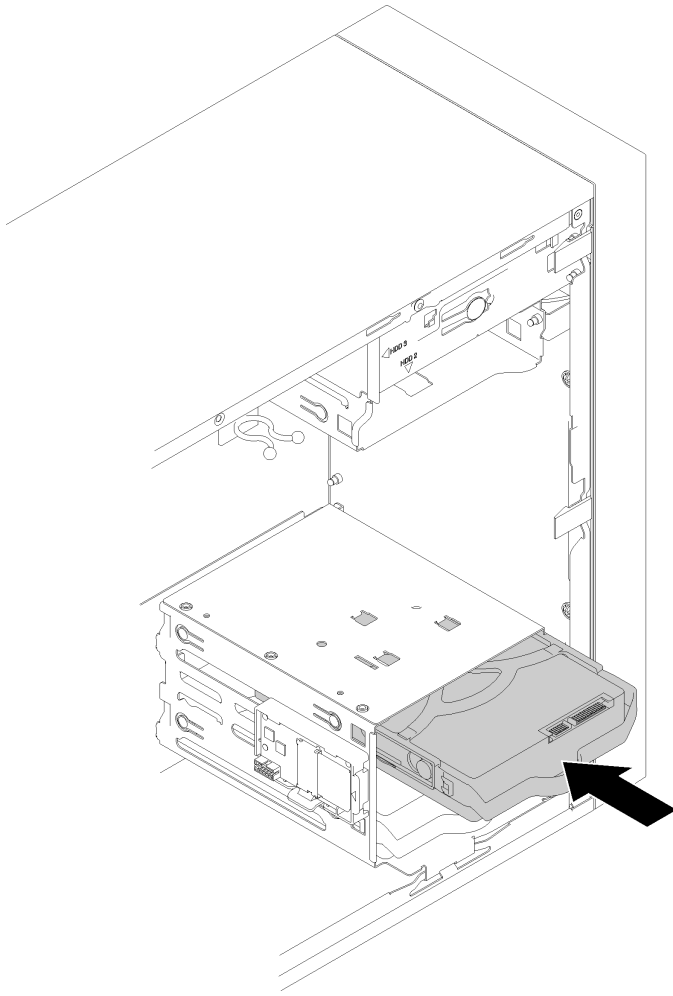

Figure 40. Installing a drive assembly into bay 2

- Bay 3

Face the connectors down, and slide the drive assembly into the drive bay.

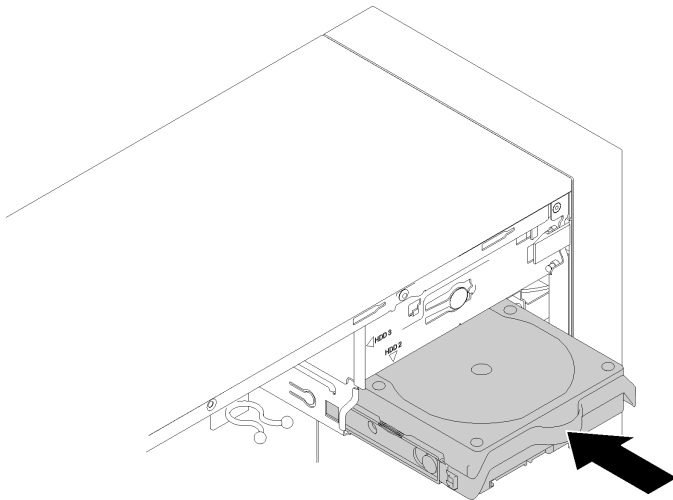

Figure 41. Installing a drive assembly into bay 3

Step 3. Connect the signal and power cable to the system board. See “Cable routing for drive bay 1-3” on page 16 for details.

After installing the simple-swap drive:

1. Install other drives if necessary.
2. Complete the parts replacement. See “Complete the parts replacement” on page 125.
3. Check the drive activity LED on the front panel to verify if the drives are operating correctly.

Table 26. Drive activity LED behavior

Status	Color	Description
Solid on	Green	The drives are active.
Off	None	The drives are not active.

4. Use the Lenovo XClarity Provisioning Manager Lite to configure the RAID if necessary. For more information, see:

http://sysmgt.lenovofiles.com/help/index.jsp?topic=%2FLXPM%2FRAID_setup.html

Optical/tape drive or drive adapter replacement (bay 4)

Follow this procedure to remove and install a optical/tape drive or drive adapter.

S006



CAUTION:

When laser products (such as CD-ROMs, DVD drives, fiber optic devices, or transmitters) are installed, note the following:

- Do not remove the covers. Removing the covers of the laser product could result in exposure to hazardous laser radiation. There are no serviceable parts inside the device.
- Use of controls or adjustments or performance of procedures other than those specified herein might result in hazardous radiation exposure.

S007



CAUTION:

This product contains a Class 1M laser. Do not view directly with optical instruments.

S008





Some laser products contain an embedded Class 3A or Class 3B laser diode. Note the following. Laser radiation when open. Do not stare into the beam, do not view directly with optical instruments, and avoid direct exposure to the beam.



This server supports the following in drive bay 4:

- One 5.25-inch optical drive
- One 5.25-inch RDX/LTO tape drive
- One 2.5-inch drive bay adapter for hard-disk or solid-state drive
- One 2.5-inch drive bay adapter for hard-disk or solid-state drive and slim optical drive

Remove an optical or tape drive

Follow this procedure to remove an optical or RDX/LTO tape drive.

Note: This section only applies to server models that come with an optical or tape drive. For those that come with a 5.25-inch drive adapter, see “Remove a 5.25-inch drive bay adapter assembly” on page 58.

	“Read the installation Guidelines” on page 31		“Power off the server for this task” on page 8		“ATTENTION: Static Sensitive Device” Ground package before opening” on page 33
---	---	---	--	--	---

S002



CAUTION:

The power control button on the device and the power switch on the power supply do not turn off the electrical current that is supplied to the device. The device also might have more than one power cord. To remove all electrical current from the device, ensure that all power cords are disconnected from the power source.

Before removing an optical or tape drive:

1. Read the safety information and installation guidelines (see “Safety” on page iii and “Installation guidelines” on page 31).
2. Turn off the server and peripheral devices, and disconnect the power cords and all external cables (see “Power off the server” on page 8).
3. If the server is in a rack, remove it from the rack.
4. Remove any locking device that secures the server cover, such as a Kensington lock or a pad lock.
5. Remove the server cover (see “Remove the server cover” on page 115).

CAUTION:

The heat sinks and processor could be very hot. To avoid from burning yourself, wait for a few minutes after turning off the server before you remove the server cover.

6. Remove the front bezel (see “Remove the front bezel” on page 83).

To remove an optical or tape drive, complete the following steps:

- Step 1. Disconnect every cable from the drive assembly.
- Step 2. Press the release tab on the side of the chassis, and slide the drive assembly out from the drive bay.

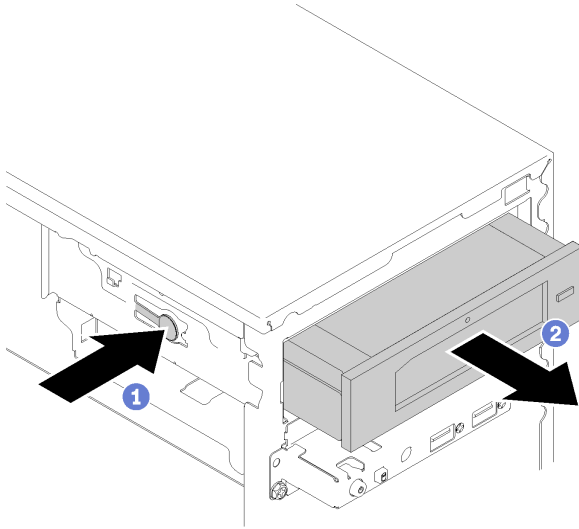

Figure 42. Removing the optical drive assembly

After removing an optical or tape drive:

1. Install one of the following:
 - A optical or tape drive (see “Install an optical or tape drive” on page 55).
 - A 5.25-inch drive bay adapter (see “Install a 5.25-inch drive bay adapter assembly” on page 62).
 - Otherwise:
 - a. Store the drive retainer into the gap on the side of the chassis for future use.

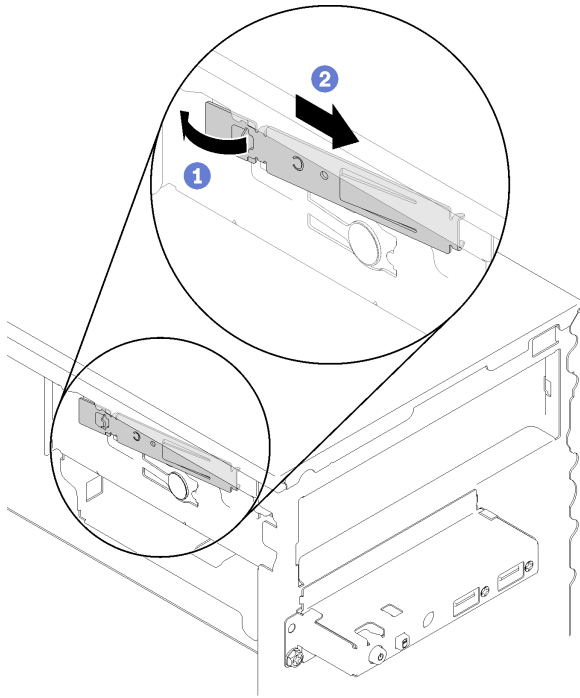

Figure 43. Storing the drive retainer

- b. Install the shield into the drive bay.

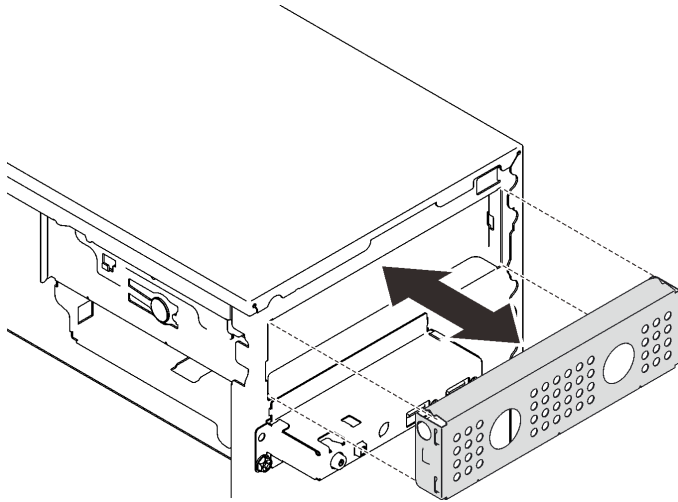

Figure 44. Installing the drive bay shield

- c. Press the filler into the slot on the front bezel until it snaps in place.

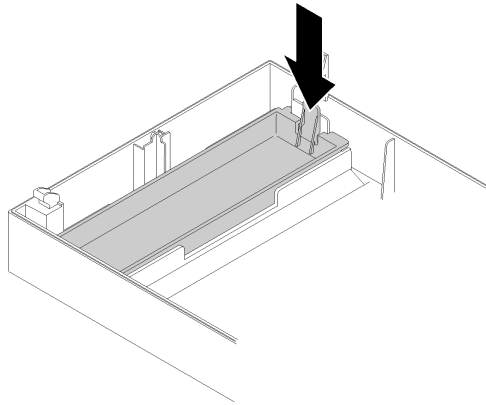

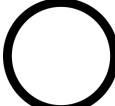



Figure 45. Installing the drive filler

- d. Install the front bezel (see “Install the front bezel” on page 85).
2. If you are instructed to return the defective component, package the part to prevent any shipping damage. Reuse the packaging of the new part that arrived, and follow all available packaging instructions.

Install an optical or tape drive

Follow this procedure to install an optical or RDX/LTO tape drive.

 <p>“Read the installation Guidelines” on page 31</p>	 <p>“Power off the server for this task” on page 8</p>	 <p>“ATTENTION: Static Sensitive Device Ground package before opening” on page 33</p>
---	--	--

S002



CAUTION:

The power control button on the device and the power switch on the power supply do not turn off the electrical current that is supplied to the device. The device also might have more than one power cord. To remove all electrical current from the device, ensure that all power cords are disconnected from the power source.

S006



CAUTION:

When laser products (such as CD-ROMs, DVD drives, fiber optic devices, or transmitters) are installed, note the following:

- Do not remove the covers. Removing the covers of the laser product could result in exposure to hazardous laser radiation. There are no serviceable parts inside the device.
- Use of controls or adjustments or performance of procedures other than those specified herein might result in hazardous radiation exposure.

S007



CAUTION:

This product contains a Class 1M laser. Do not view directly with optical instruments.

Before installing an optical or tape drive:

1. If the front bezel is installed, remove it (see “Remove the front bezel” on page 83).
2. Touch the static-protective package that contains the component to any unpainted metal surface on the server; then, remove it from the package and place it on a static-protective surface.

To install an optical or tape drive, complete the following steps:

Step 1. Align the retainer on the side of the optical or tape drive and install it.

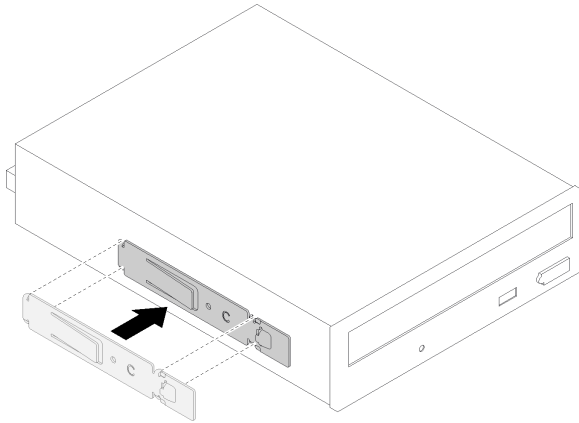

Figure 46. Installing the drive retainer to an optical drive

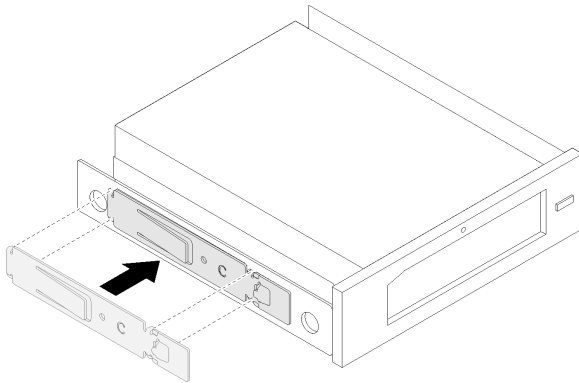

Figure 47. Installing the drive retainer to a tape drive

Step 2. Align the optical or tape drive to the drive bay, and slide it in until it snaps into place.

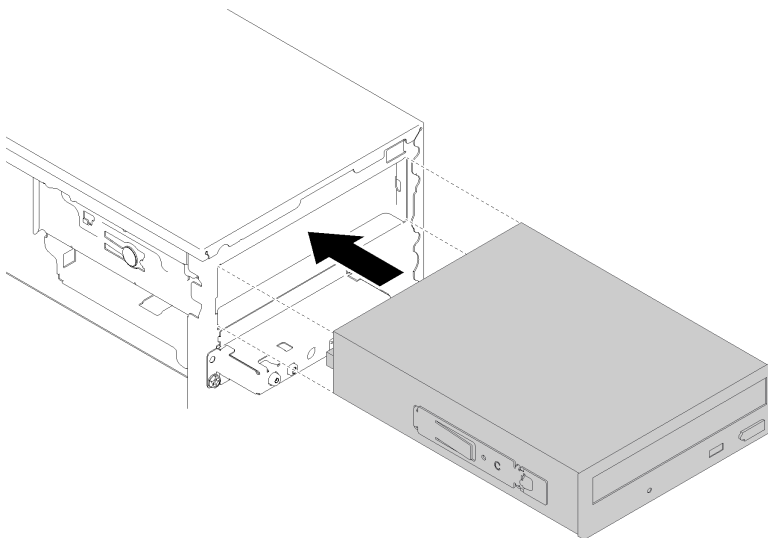

Figure 48. Installing the optical drive assembly

Step 3. Connect the power cable and the signal cable to the system board. For more information about cable routing, see “Cable routing for drive bay 4” on page 18.



After installing the optical or tape drive:

1. Install the front bezel (see “Install the front bezel” on page 85).
2. Proceed to complete the parts replacement (see “Complete the parts replacement” on page 125).

Remove a 5.25-inch drive bay adapter assembly

Follow this procedure to remove a 5.25-inch drive bay adapter assembly.

Note: This section only applies to server models that come with a 5.25-inch drive bay adapter. For those that come with an optical or tape drive, see “Remove an optical or tape drive” on page 52.

	“Read the installation Guidelines” on page 31		“Power off the server for this task” on page 8		“ATTENTION: Static Sensitive Device Ground package before opening” on page 33
---	---	---	--	--	---

S002



CAUTION:

The power control button on the device and the power switch on the power supply do not turn off the electrical current that is supplied to the device. The device also might have more than one power cord. To remove all electrical current from the device, ensure that all power cords are disconnected from the power source.

Before removing a 5.25-inch drive bay adapter assembly:

1. Read the safety information and installation guidelines (see “Safety” on page iii and “Installation guidelines” on page 31).
2. Turn off the server and peripheral devices, and disconnect the power cords and all external cables (see “Power off the server” on page 8).
3. If the server is in a rack, remove it from the rack.
4. Remove any locking device that secures the server cover, such as a Kensington lock or a pad lock.
5. Remove the server cover (see “Remove the server cover” on page 115).

CAUTION:

The heat sinks and processor could be very hot. To avoid from burning yourself, wait for a few minutes after turning off the server before you remove the server cover.

6. Remove the front bezel (see “Remove the front bezel” on page 83).

To remove a drive bay adapter assembly, complete the following steps:

Step 1. Disconnect every cable from the adapter assembly.

- Step 2. Press the release tab on the side of the chassis, and slide the adapter assembly towards the front of the server to remove it.

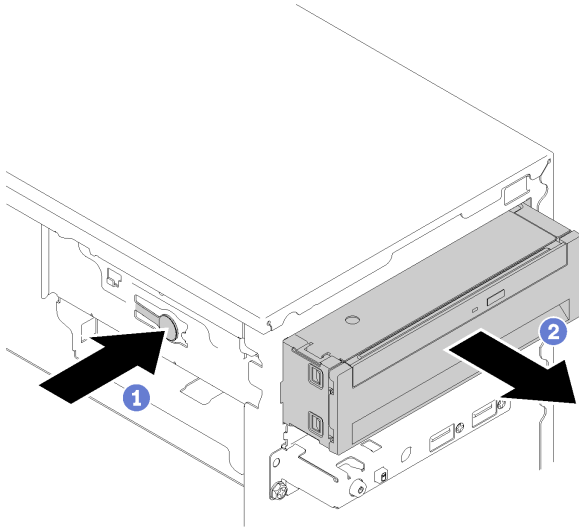

Figure 49. Removing the 5.25-inch drive bay adapter assembly

- Step 3. Remove the following components from the adapter if necessary:

Slim optical drive

- a. Press the release tab on the top of the adapter, and slide the slim optical drive out from the adapter.

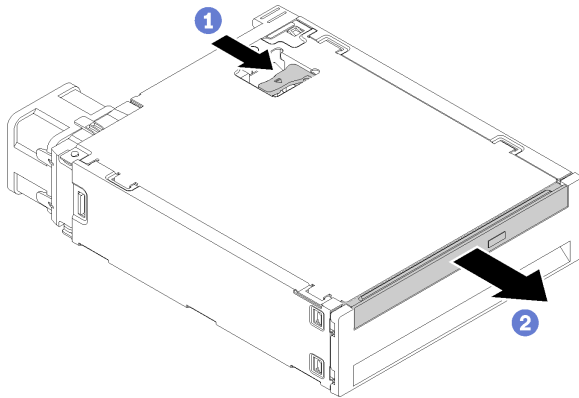

Figure 50. Removing the slim optical drive from the drive bay adapter

Simple-swap drive

- a. Pinch the release tab on the rear of the drive assembly as illustrated; then, pivot the latch to the open position.

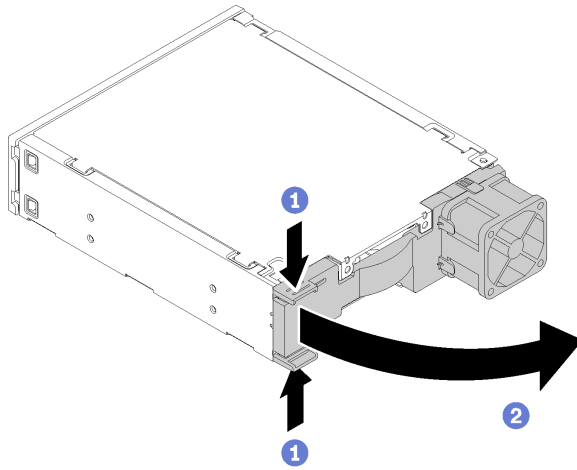

Figure 51. Opening the latch of the adapter assembly

- b. Grasp the handle on the retainer and slide the drive out from the adapter.

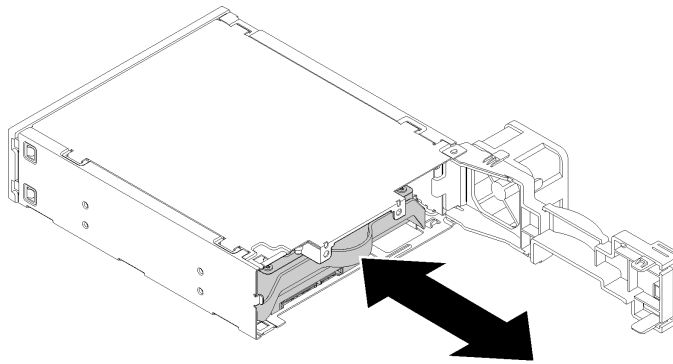

Figure 52. Removing the storage drive from the drive adapter

After removing the 5.25-inch drive bay adapter assembly:

1. Install one of the following:
 - An optical or tape drive (see “Install an optical or tape drive” on page 55).
 - a 5.25-inch drive bay adapter see “Install a 5.25-inch drive bay adapter assembly” on page 62).
 - Otherwise:
 - a. Store the drive retainer into the gap on the side of the chassis for future use.

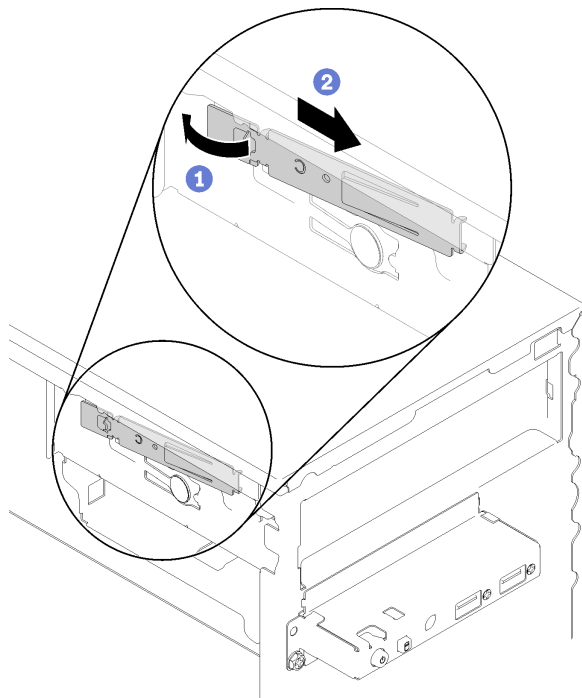

Figure 53. Storing the drive retainer

- b. Install the shield into the drive bay.

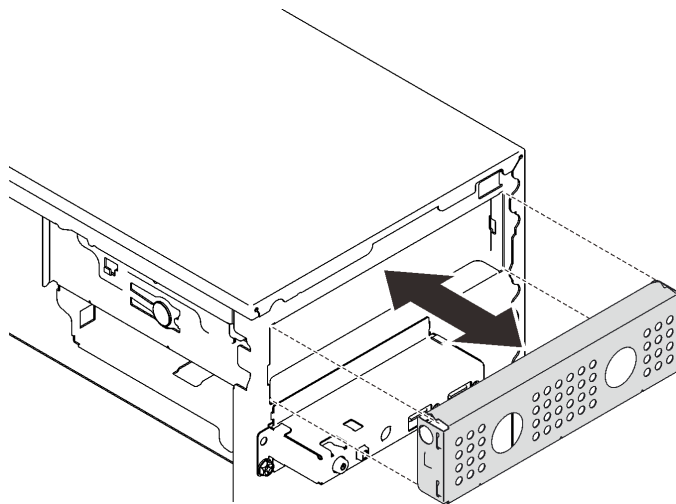

Figure 54. Installing the drive bay shield

- c. Press the filler into the slot on the front bezel until it snaps in place.

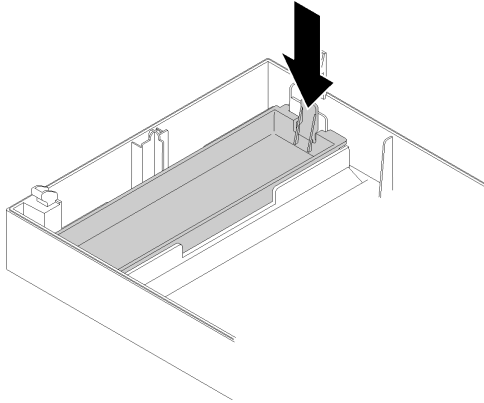

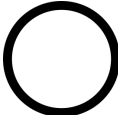



Figure 55. Installing the drive filler

- d. Install the front bezel (see “Install the front bezel” on page 85).
2. If you are instructed to return the defective component, package the part to prevent any shipping damage. Reuse the packaging of the new part that arrived, and follow all available packaging instructions.

Install a 5.25-inch drive bay adapter assembly

Follow this procedure to install a 5.25-inch drive bay adapter assembly.

 <p>“Read the installation Guidelines” on page 31</p>	 <p>“Power off the server for this task” on page 8</p>	 <p>“ATTENTION: Static Sensitive Device Ground package before opening” on page 33</p>
---	--	--

S002

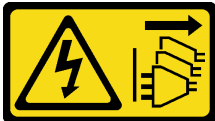

CAUTION:

The power control button on the device and the power switch on the power supply do not turn off the electrical current that is supplied to the device. The device also might have more than one power cord. To remove all electrical current from the device, ensure that all power cords are disconnected from the power source.

Before installing a 5.25-inch drive bay adapter assembly:

1. If the front bezel is installed, remove it (see “Remove the front bezel” on page 83).
2. Touch the static-protective package that contains the component to any unpainted metal surface on the server; then, remove it from the package and place it on a static-protective surface.

To install a 5.25-inch drive bay adapter assembly, complete the following steps:

Step 1. Install the components into the drive bay adapter if necessary:

Slim optical drive

- a. Align the screw holes on the retainer to the corresponding ones on the slim optical drive, and secure the retainer with two screws.

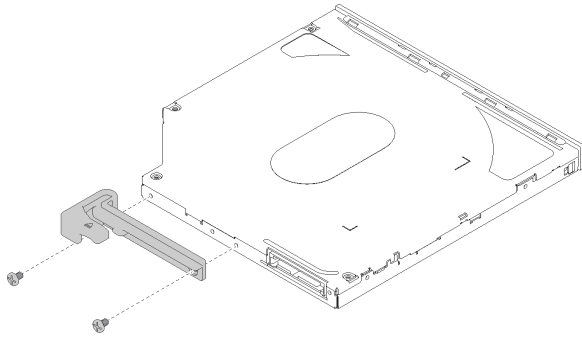

Figure 56. Installing the retainer to the slim optical drive

- b. Slide the slim optical drive into the slot on the front of the drive adapter until it snaps into place.

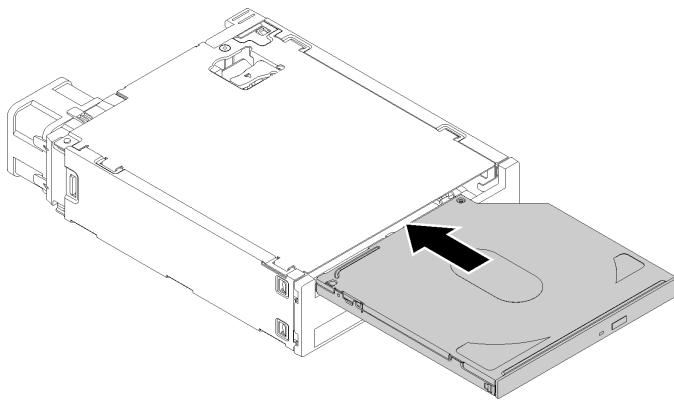

Figure 57. Installing the slim optical drive into the drive bay adapter

Simple-swap drive

- a. Pinch the release tab on the rear of the drive assembly as illustrated; then, pivot the latch to the open position.

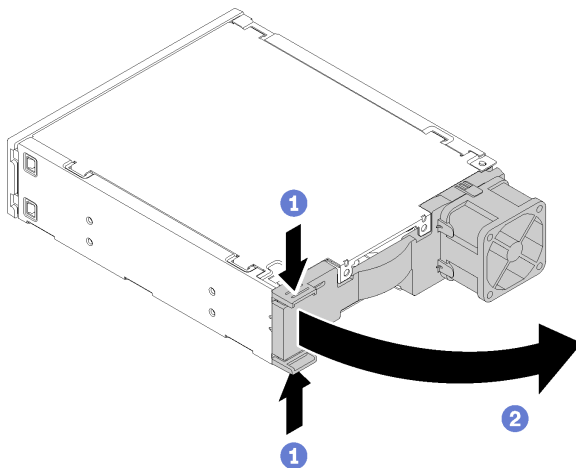

Figure 58. Opening the latch of the adapter assembly

- b. Slightly tear both sides of the retainer apart; then, fit the drive in the retainer.
- c. Align the four holes on the drive with the corresponding pins on the retainer, and lower the drive until it is secured in the retainer.

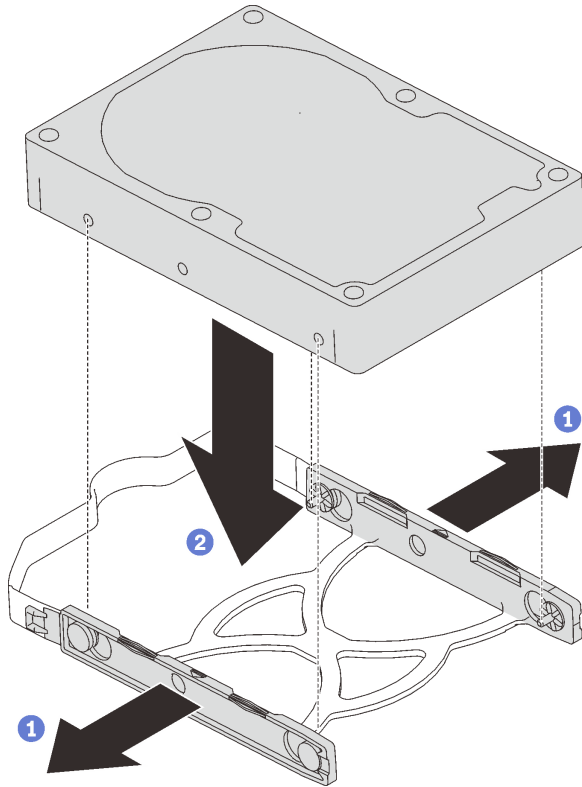

Figure 59. Installing a 3.5-inch drive into the retainer

2.5-inch drive

- d. Slide the drive assembly into the drive adapter.

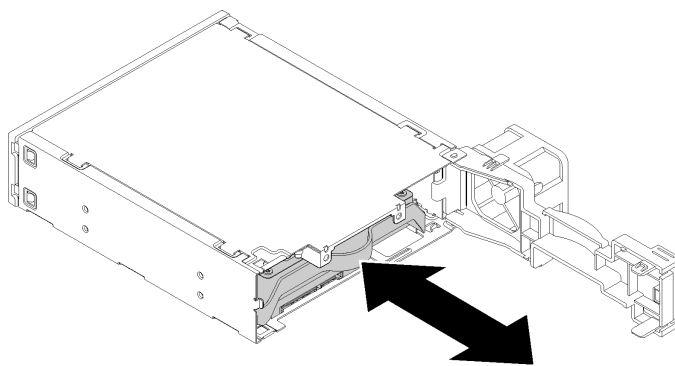

Figure 60. Installing the drive assembly into the drive adapter

- e. Close the drive adapter latch.

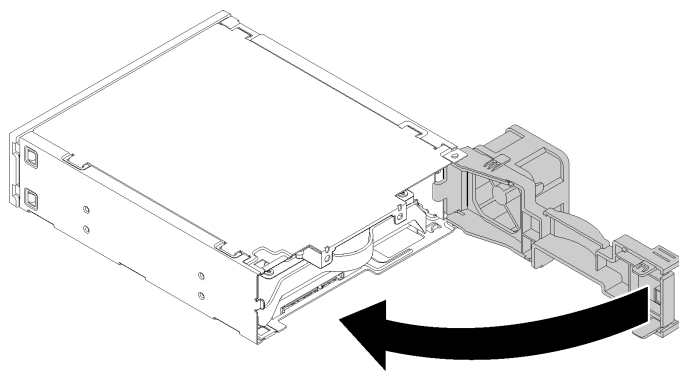

Figure 61. Closing the drive adapter latch

Step 2. Slide the drive bay adapter assembly slide into drive 3 until it clicks into place.

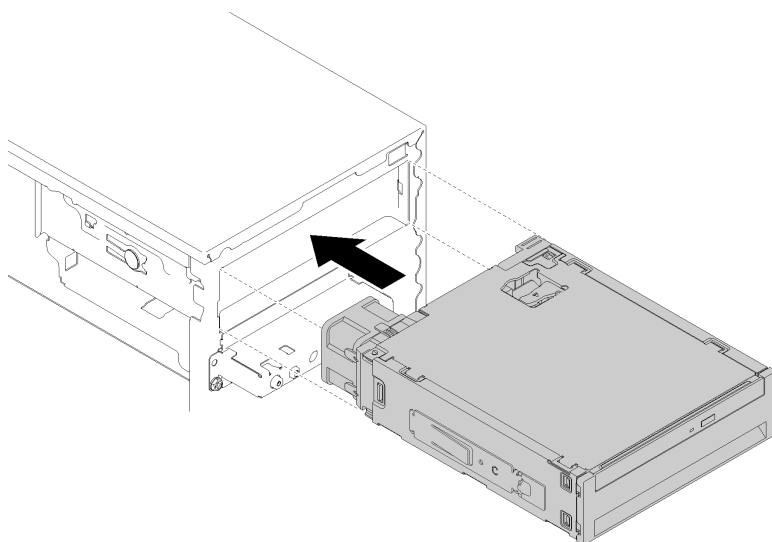

Figure 62. Installing the drive bay adapter assembly

Step 3. Connect the power cable and the signal cable to the system board. For more information about the cable routing, see “Cable routing for drive bay 4” on page 18.

After installing the drive bay adapter assembly:

1. Install the front bezel (see “Install the front bezel” on page 85).
2. Proceed to complete the parts replacement (see “Complete the parts replacement” on page 125).
3. Reconfigure the RAID settings if necessary.

Dual SD card adapter replacement

Follow this procedure to remove and install the dual SD card adapter.

For details concerning the components of dual SD card adapter, see “Dual SD card adapter module” on page 14.

Remove the dual SD card adapter

Follow this procedure to remove the dual SD card adapter.

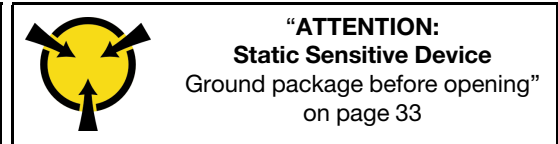
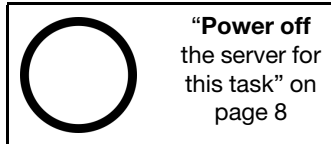

S002

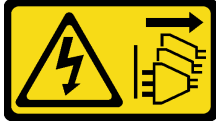

CAUTION:

The power control button on the device and the power switch on the power supply do not turn off the electrical current that is supplied to the device. The device also might have more than one power cord. To remove all electrical current from the device, ensure that all power cords are disconnected from the power source.

Before removing the dual SD card adapter:

1. Read the safety information and installation guidelines (see “Safety” on page iii and “Installation guidelines” on page 31).
2. Turn off the server and peripheral devices, and disconnect the power cords and all external cables (see “Power off the server” on page 8).
3. If the server is in a rack, remove it from the rack.
4. Remove any locking device that secures the server cover, such as a Kensington lock or a pad lock.
5. Remove the server cover (see “Remove the server cover” on page 115).

CAUTION:

The heat sinks and processor could be very hot. To avoid from burning yourself, wait for a few minutes after turning off the server before you remove the server cover.

To remove the dual SD card adapter, complete the following steps:

- Step 1. Disconnect the cable from the adapter.
- Step 2. Press and hold the release tab as illustrated; then, pivot the adapter away from the retainer.

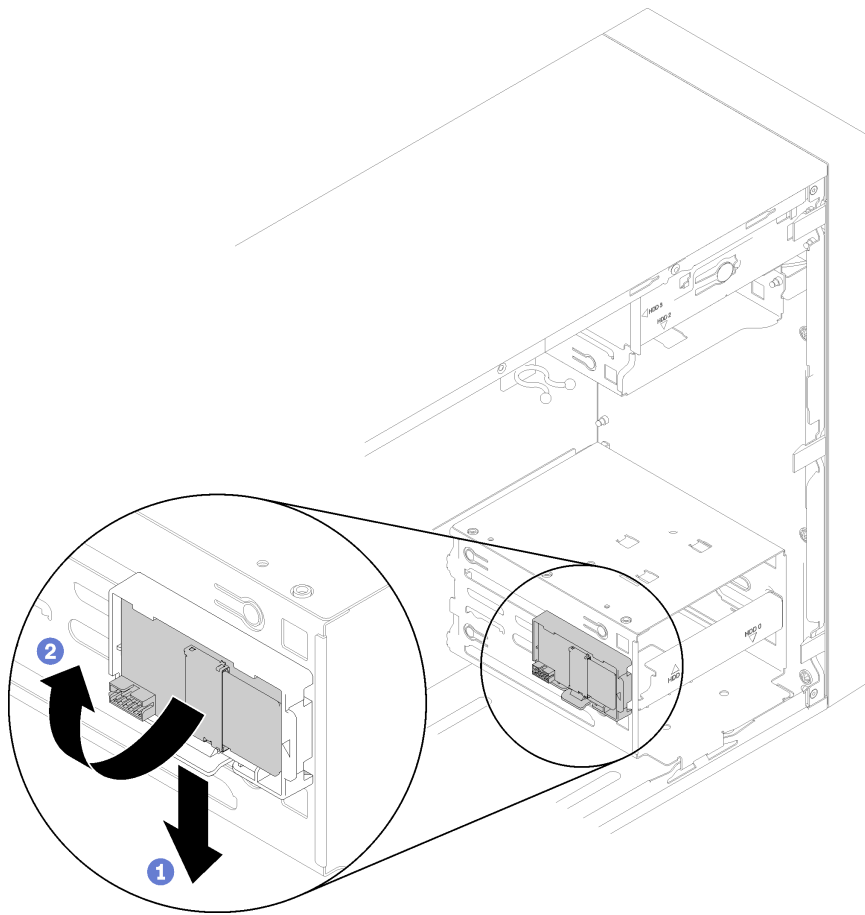

Figure 63. Removing the dual SD card adapter

Step 3. Slide the SD cards out from the slots to remove them if necessary.

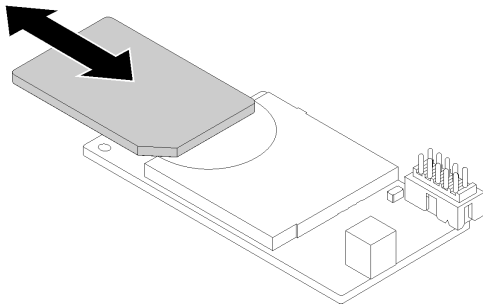

Figure 64. Removing a SD card from the dual SD card adapter

Step 4. If necessary, remove the screw that secures the module retainer to the chassis, and slide it towards the left side of the server to remove it.

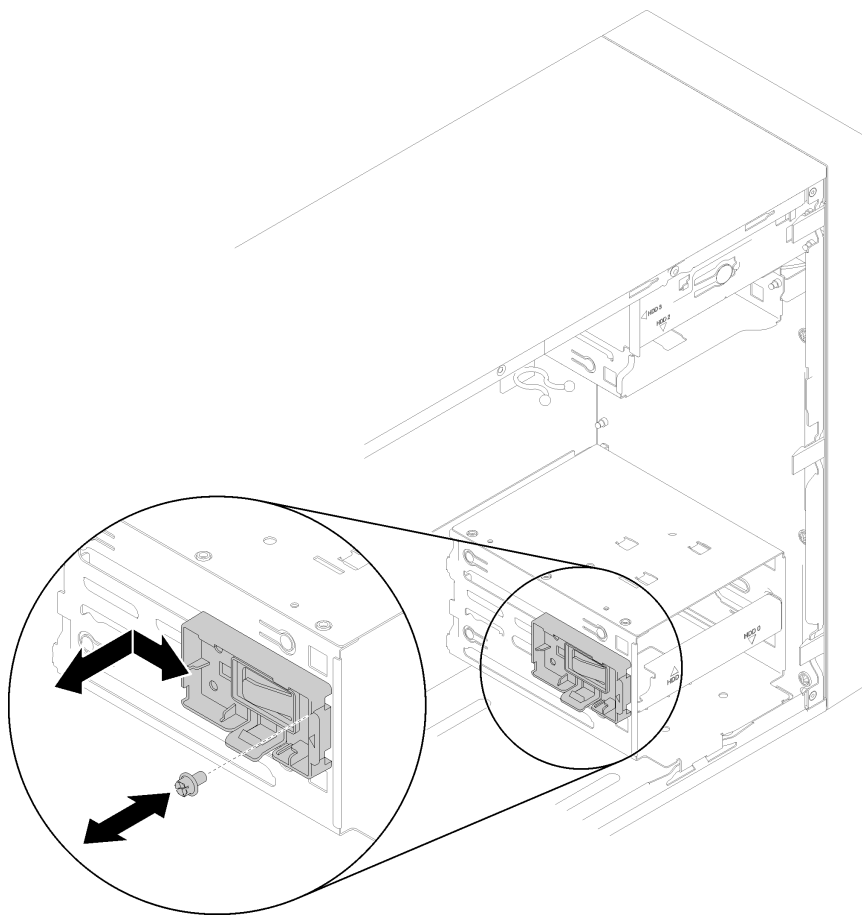



Figure 65. Removing the dual SD card adapter retainer

After removing the dual SD card adapter:

1. If you are instructed to return the defective component, package the part to prevent any shipping damage. Reuse the packaging of the new part that arrived, and follow all available packaging instructions.

Install the dual SD card adapter

Follow this procedure to install the dual SD card adapter.

 <p>“Read the installation Guidelines” on page 31</p>	 <p>“ATTENTION: Static Sensitive Device Ground package before opening” on page 33</p>
---	---

S002

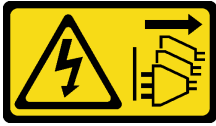

CAUTION:

The power control button on the device and the power switch on the power supply do not turn off the electrical current that is supplied to the device. The device also might have more than one power cord. To remove all electrical current from the device, ensure that all power cords are disconnected from the power source.

Before installing the dual SD card adapter:

1. If the adapter retainer is not installed, secure it to the chassis with a screw as illustrated.

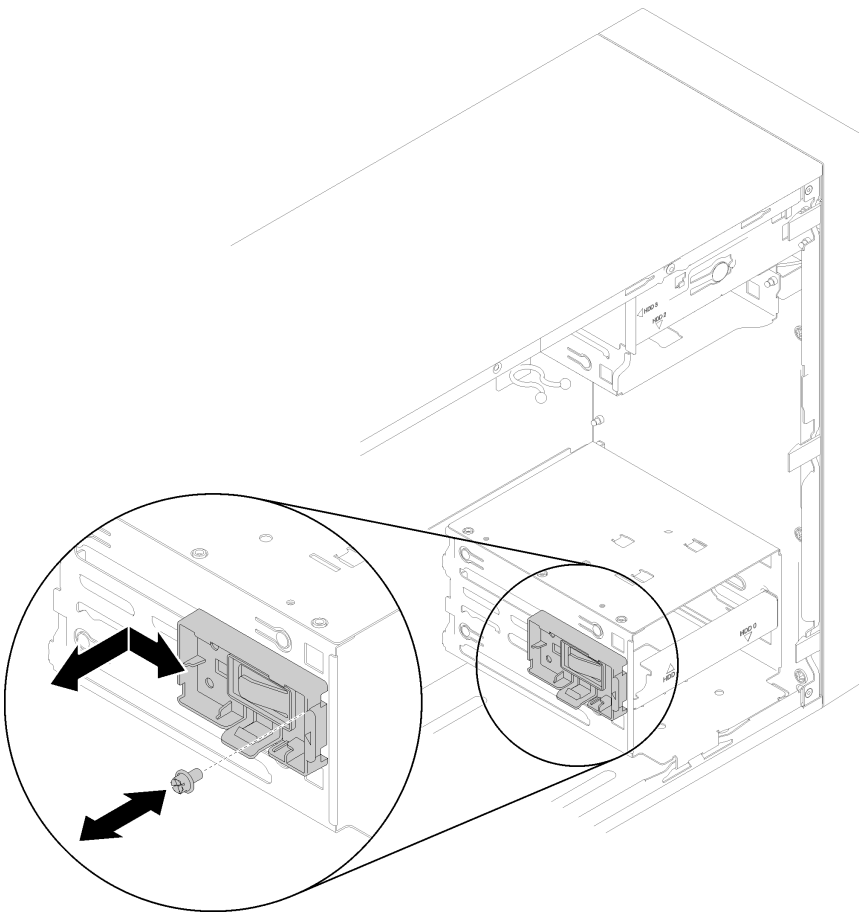

Figure 66. Installing the dual SD card adapter retainer

2. Touch the static-protective package that contains the component to any unpainted metal surface on the server; then, remove it from the package and place it on a static-protective surface.

To install the dual SD card adapter, complete the following steps:

Step 1. Slide the SD cards into the slots on the dual SD card adapter if necessary.

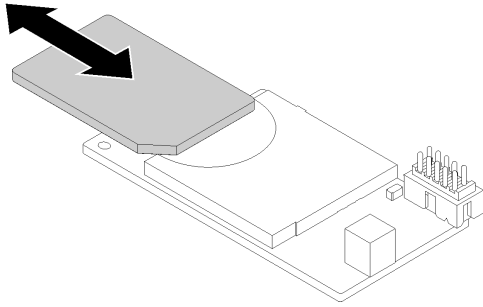

Figure 67. Installing a SD card into the dual SD card adapter

Step 2. Align the adapter to the retainer and press it until it snaps in place.

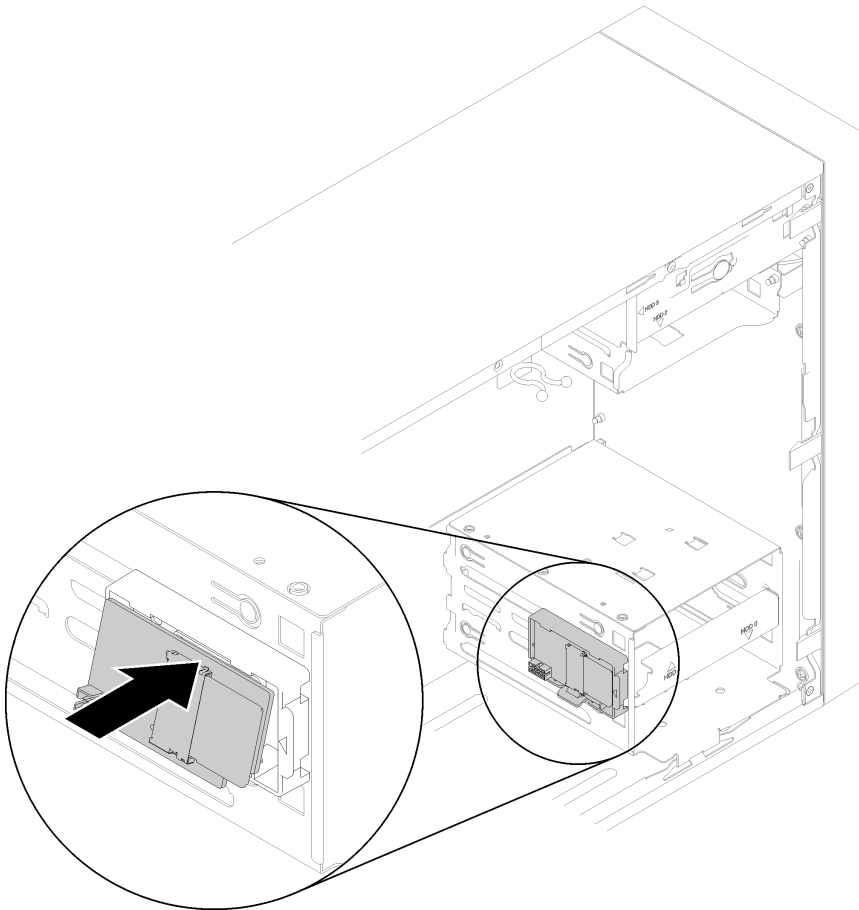

Figure 68. Installing the dual SD card adapter

Step 3. Connect the cable to the system board. To locate the connector on the system board, see “System board components” on page 13.

After installing the dual SD card adapter:

1. Proceed to complete the parts replacement (see “Complete the parts replacement” on page 125).

Fan replacement

Follow this procedure to remove and install the front or rear fan.

Note: For heat sink and fan module replacement, see “Heat sink and fan module replacement” on page 90.

Remove the front fan

Follow this procedure to remove the front fan.

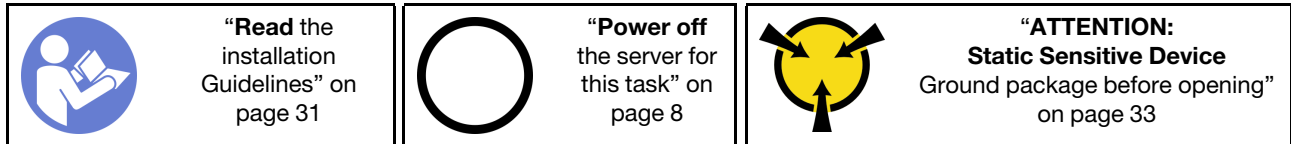

S002



CAUTION:

The power control button on the device and the power switch on the power supply do not turn off the electrical current that is supplied to the device. The device also might have more than one power cord. To remove all electrical current from the device, ensure that all power cords are disconnected from the power source.

Before removing the front fan:

1. Read the safety information and installation guidelines (see “Safety” on page iii and “Installation guidelines” on page 31).
2. Turn off the server and peripheral devices, and disconnect the power cords and all external cables (see “Power off the server” on page 8).
3. If the server is in a rack, remove it from the rack.
4. Remove any locking device that secures the server cover, such as a Kensington lock or a pad lock.
5. Remove the server cover (see “Remove the server cover” on page 115).

CAUTION:

The heat sinks and processor could be very hot. To avoid from burning yourself, wait for a few minutes after turning off the server before you remove the server cover.

6. Remove the front bezel (see “Remove the front bezel” on page 83).

To remove the front fan, complete the following steps:

Step 1. Disconnect the fan cable from the system board; then, route the cable out from the chassis.

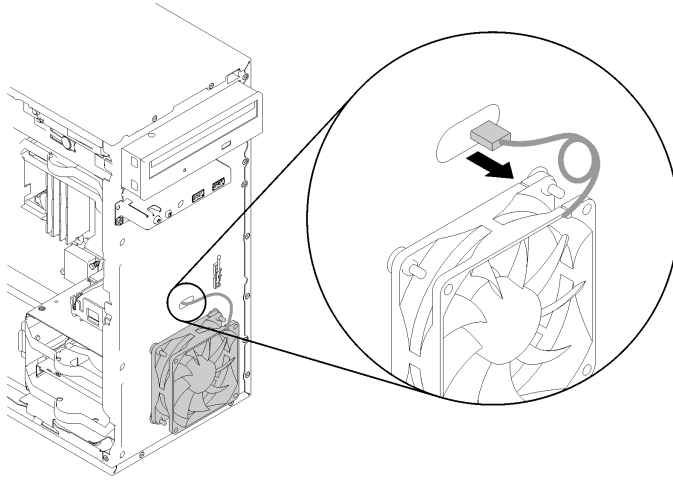

Figure 69. Routing front fan cable out

Step 2. Lift the fan slightly to detach and remove it from the chassis.

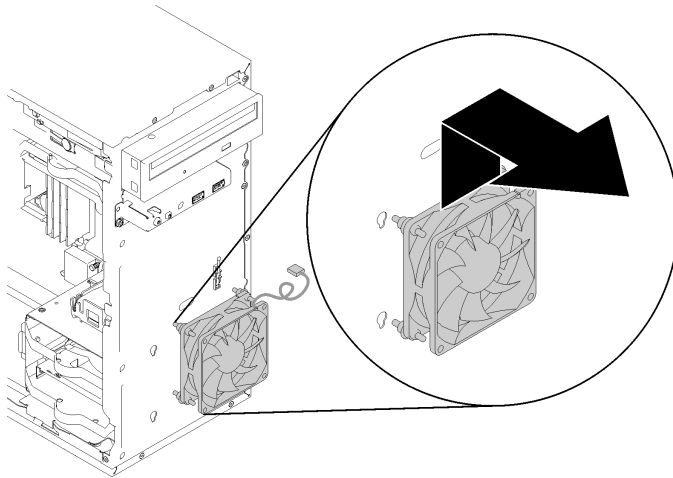

Figure 70. Removing the front fan

After removing the front fan:

1. Install a new front fan (see “Install the front fan” on page 72).
2. If you are instructed to return the defective component, package the part to prevent any shipping damage. Reuse the packaging of the new part that arrived, and follow all available packaging instructions.

Install the front fan

Follow this procedure to install the front fan.

	<p>“Read the installation Guidelines” on page 31</p>	<p>“Power off the server for this task” on page 8</p>	<p>“ATTENTION: Static Sensitive Device Ground package before opening” on page 33</p>
--	--	---	--

S002

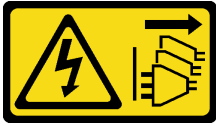

CAUTION:

The power control button on the device and the power switch on the power supply do not turn off the electrical current that is supplied to the device. The device also might have more than one power cord. To remove all electrical current from the device, ensure that all power cords are disconnected from the power source.

Before installing the front fan:

1. If a front fan has been installed, remove it (see “Remove the front fan” on page 71).
2. Touch the static-protective package that contains the component to any unpainted metal surface on the server; then, remove it from the package and place it on a static-protective surface.

To install the front fan, complete the following steps:

- Step 1. Align the four rubber mounts on the front fan assembly with the corresponding holes on the front of the chassis; then, push and lower the fan until it is secured to the chassis with the rubber mounts.

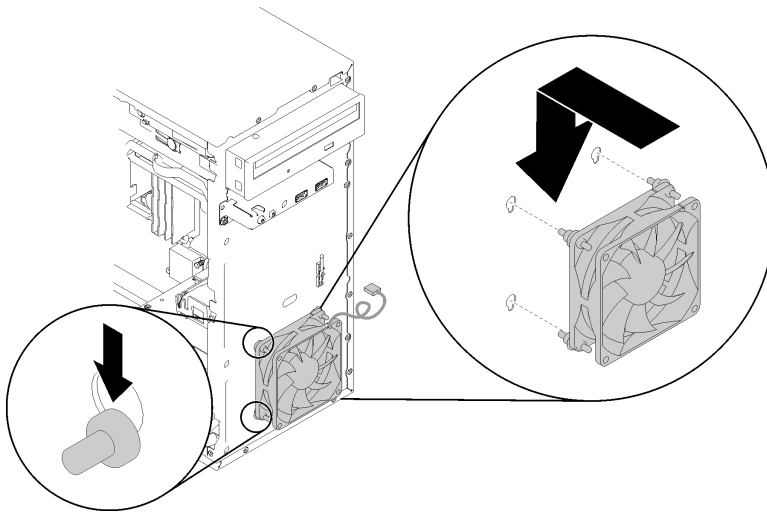

Figure 71. Installing the front fan

- Step 2. Route the fan cable through the hole on the front of the chassis as illustrated.

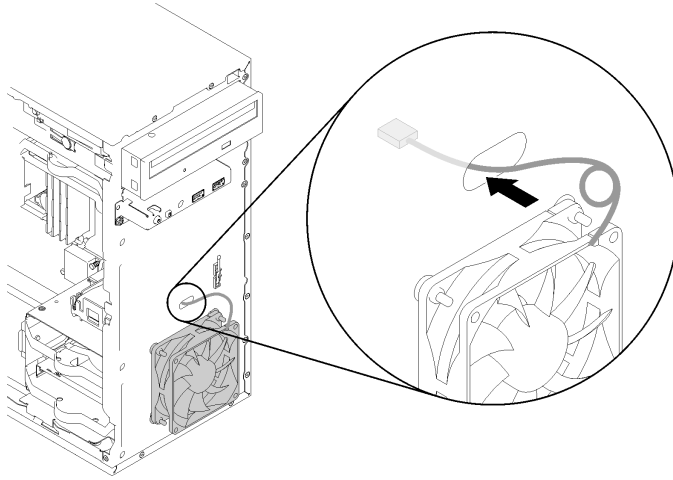

Figure 72. Routing the front fan cable

Step 3. Connect the fan cable to the system board (see “Cable routing for the fans” on page 24).

After installing the front fan:

1. Install the front bezel (see “Install the front bezel” on page 85).
2. Proceed to complete the parts replacement (see “Complete the parts replacement” on page 125).

Remove the rear fan

Follow this procedure to remove the rear fan.

	<p>“Read the installation Guidelines” on page 31</p>		<p>“Power off the server for this task” on page 8</p>		<p>“ATTENTION: Static Sensitive Device Ground package before opening” on page 33</p>
--	--	--	---	--	--

S002



CAUTION:

The power control button on the device and the power switch on the power supply do not turn off the electrical current that is supplied to the device. The device also might have more than one power cord. To remove all electrical current from the device, ensure that all power cords are disconnected from the power source.

Before removing the rear fan:

1. Read the safety information and installation guidelines (see “Safety” on page iii and “Installation guidelines” on page 31).
2. Turn off the server and peripheral devices, and disconnect the power cords and all external cables (see “Power off the server” on page 8).
3. If the server is in a rack, remove it from the rack.
4. Remove any locking device that secures the server cover, such as a Kensington lock or a pad lock.
5. Remove the server cover (see “Remove the server cover” on page 115).

CAUTION:

The heat sinks and processor could be very hot. To avoid from burning yourself, wait for a few minutes after turning off the server before you remove the server cover.

To remove the rear fan, complete the following steps:

- Step 1. Disconnect the fan cable from the system board.
- Step 2. Cut off the four rubber mounts that secure the fan to the chassis from the external side; then, remove the fan.

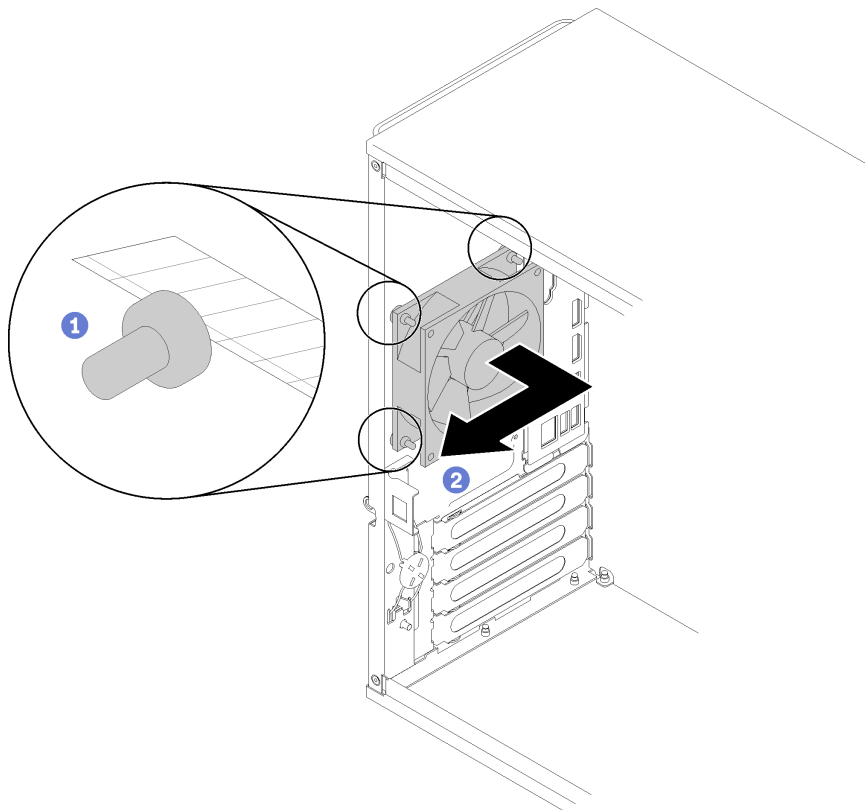



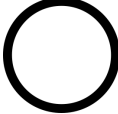

Figure 73. Removing the rear fan

After removing the rear fan:

1. Install a new rear fan. See (“Install the rear fan” on page 76).
2. If you are instructed to return the defective component, package the part to prevent any shipping damage. Reuse the packaging of the new part that arrived, and follow all available packaging instructions.

Install the rear fan

Follow this procedure to install the rear fan.

 <p>“Read the installation Guidelines” on page 31</p>	 <p>“Power off the server for this task” on page 8</p>	 <p>“ATTENTION: Static Sensitive Device Ground package before opening” on page 33</p>
--	---	---

S002



CAUTION:

The power control button on the device and the power switch on the power supply do not turn off the electrical current that is supplied to the device. The device also might have more than one power cord. To remove all electrical current from the device, ensure that all power cords are disconnected from the power source.

Before installing the rear fan

1. Touch the static-protective package that contains the component to any unpainted metal surface on the server; then, remove it from the package and place it on a static-protective surface.

To install the rear fan, complete the following steps:

Step 1. Align the four rubber mounts on the rear fan with the corresponding holes on the rear of the chassis.

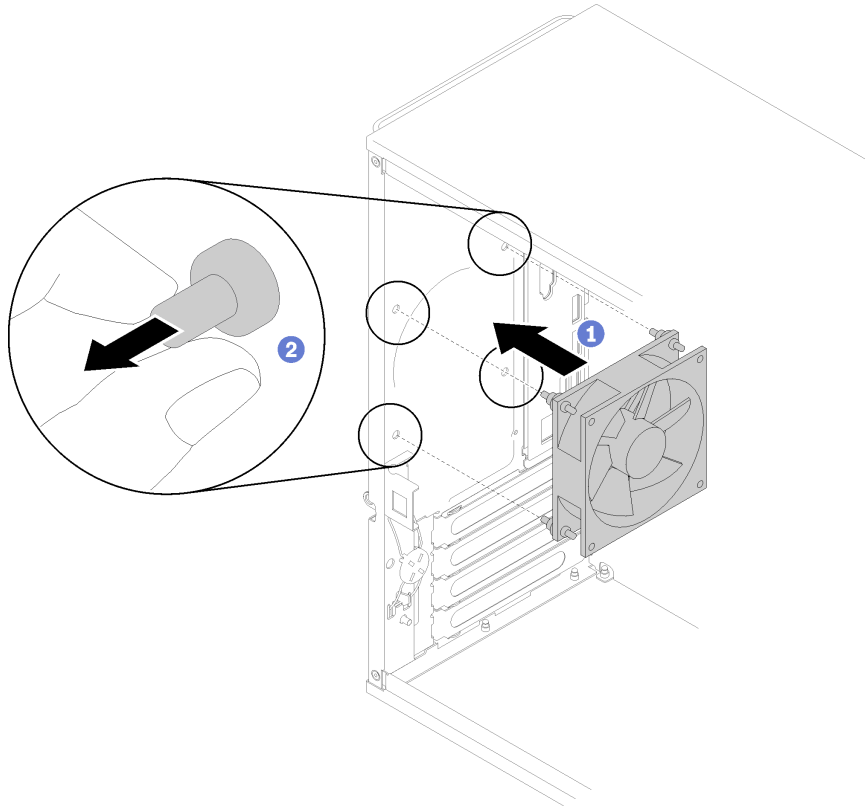

Figure 74. Installing the rear fan

Step 2. Gently pull the tips of the four rubber mounts out from the holes until the rear fan is secured to the chassis.

Step 3. Connect the fan cable to the system board (see “Cable routing for the fans” on page 24).

After installing the rear fan:



1. Proceed to complete the parts replacement (see “Complete the parts replacement” on page 125).

Flash power module replacement

Follow this procedure to remove and install a flash power module.

Remove the flash power module

Follow this procedure to remove the flash power module.

	<p>“Read the installation Guidelines” on page 31</p>		<p>“Power off the server for this task” on page 8</p>		<p>“ATTENTION: Static Sensitive Device Ground package before opening” on page 33</p>
---	--	---	---	--	--

S002

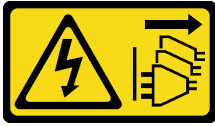

CAUTION:

The power control button on the device and the power switch on the power supply do not turn off the electrical current that is supplied to the device. The device also might have more than one power cord. To remove all electrical current from the device, ensure that all power cords are disconnected from the power source.

S004



CAUTION:

When replacing the lithium battery, use only Lenovo specified part number or an equivalent type battery recommended by the manufacturer. If your system has a module containing a lithium battery, replace it only with the same module type made by the same manufacturer. The battery contains lithium and can explode if not properly used, handled, or disposed of. *Do not:*

- Throw or immerse into water
- Heat to more than 100°C (212°F)
- Repair or disassemble

Dispose of the battery as required by local ordinances or regulations.

S005



CAUTION:

The battery is a lithium ion battery. To avoid possible explosion, do not burn the battery. Exchange it only with the approved part. Recycle or discard the battery as instructed by local regulations.

Before removing the flash power module:

1. Read the safety information and installation guidelines (see “Safety” on page iii and “Installation guidelines” on page 31).
2. Turn off the server and peripheral devices, and disconnect the power cords and all external cables (see “Power off the server” on page 8).
3. If the server is in a rack, remove it from the rack.
4. Remove any locking device that secures the server cover, such as a Kensington lock or a pad lock.
5. Remove the server cover (see “Remove the server cover” on page 115).

CAUTION:

The heat sinks and processor could be very hot. To avoid from burning yourself, wait for a few minutes after turning off the server before you remove the server cover.

To remove the flash power module, complete the following steps:

- Step 1. Disconnect the cable from the RAID adapter.
- Step 2. Press the release tab on the side of the retainer; then, remove the flash power module retainer assembly.

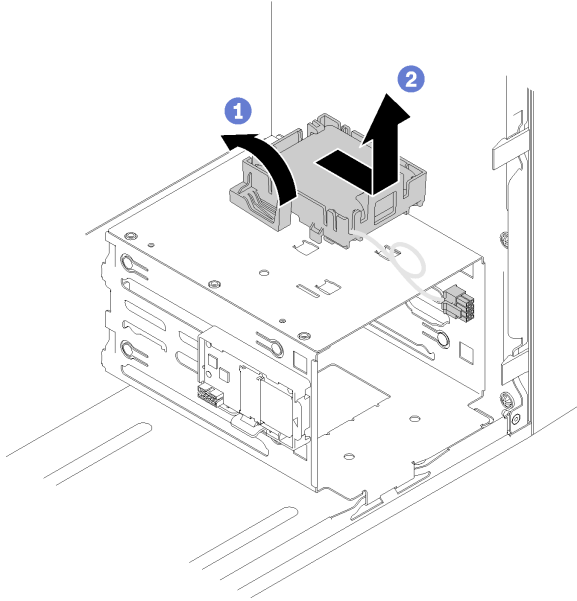

Figure 75. Removing the RAID flash power module assembly

- Step 3. Press the release tab on the retainer, and pivot the flash power module to remove it from the retainer.

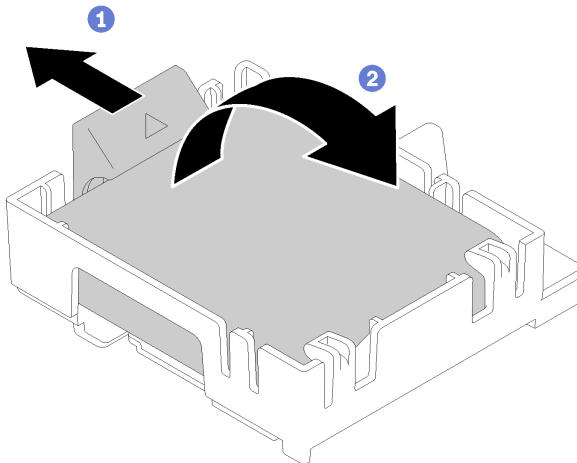



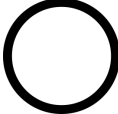

Figure 76. Removing the RAID flash power module from the retainer

After removing the flash power module:

1. If you are instructed to return the defective component, package the part to prevent any shipping damage. Reuse the packaging of the new part that arrived, and follow all available packaging instructions.

Install the flash power module

Follow this procedure to install the flash power module.

	“Read the installation Guidelines” on page 31		“Power off the server for this task” on page 8		“ATTENTION: Static Sensitive Device Ground package before opening” on page 33
---	--	---	---	--	--

S002



CAUTION:

The power control button on the device and the power switch on the power supply do not turn off the electrical current that is supplied to the device. The device also might have more than one power cord. To remove all electrical current from the device, ensure that all power cords are disconnected from the power source.

S004



CAUTION:

When replacing the lithium battery, use only Lenovo specified part number or an equivalent type battery recommended by the manufacturer. If your system has a module containing a lithium battery, replace it only with the same module type made by the same manufacturer. The battery contains lithium and can explode if not properly used, handled, or disposed of. *Do not:*

- Throw or immerse into water
- Heat to more than 100°C (212°F)
- Repair or disassemble

Dispose of the battery as required by local ordinances or regulations.

S005



CAUTION:

The battery is a lithium ion battery. To avoid possible explosion, do not burn the battery. Exchange it only with the approved part. Recycle or discard the battery as instructed by local regulations.

Before installing the flash power module:

1. If the flash power module retainer has been installed to the server, press the release tab on the side of the retainer and remove it.

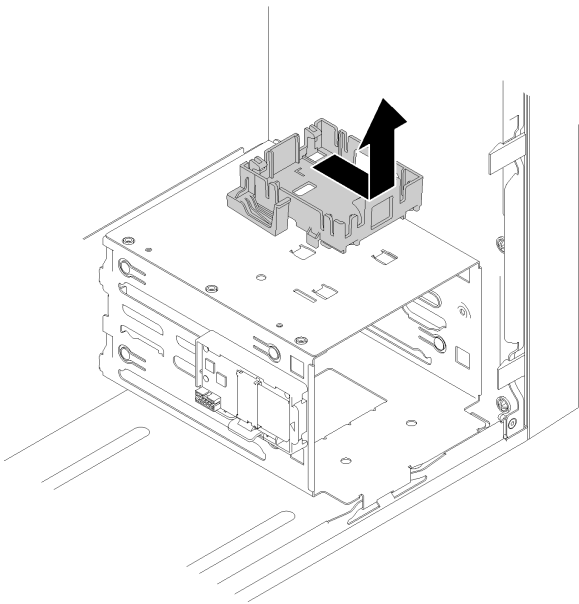

Figure 77. Removing the flash power module retainer

2. If the RAID adapter has been installed, remove it (see “Remove a PCIe adapter” on page 99).
3. Touch the static-protective package that contains the component to any unpainted metal surface on the server; then, remove it from the package and place it on a static-protective surface.

To install the flash power module, complete the following steps:

Step 1. Press the release tab, and align the bottom of the flash power module to the slot on the retainer; then, firmly press the flash power module until it snaps in place.

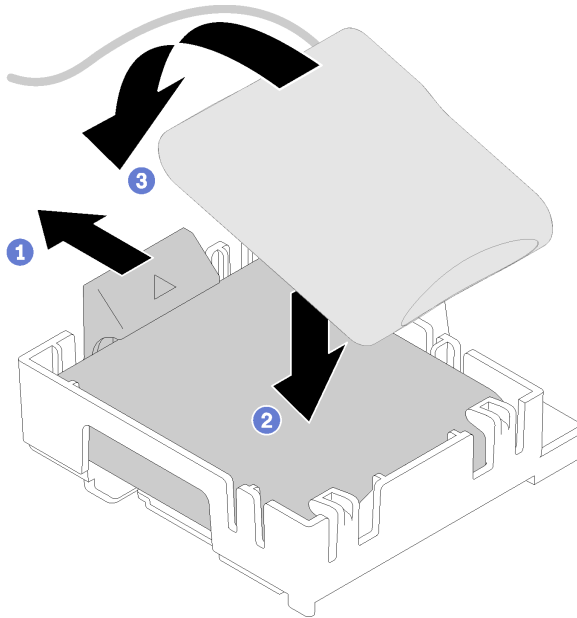

Figure 78. Installing the flash power module into the retainer

Step 2. Align the flash power module assembly with the corresponding holes on the chassis, and slide it forward until it snaps in place.

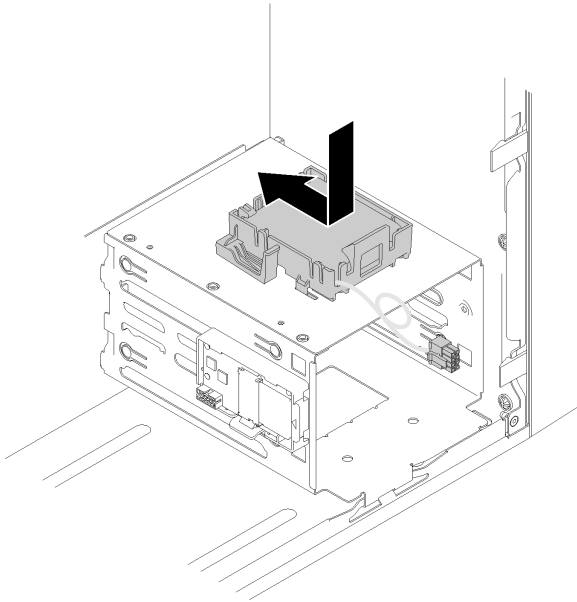

Figure 79. Installing the flash power module assembly

Step 3. Connect the cable to the flash power module adapter and the RAID adapter.

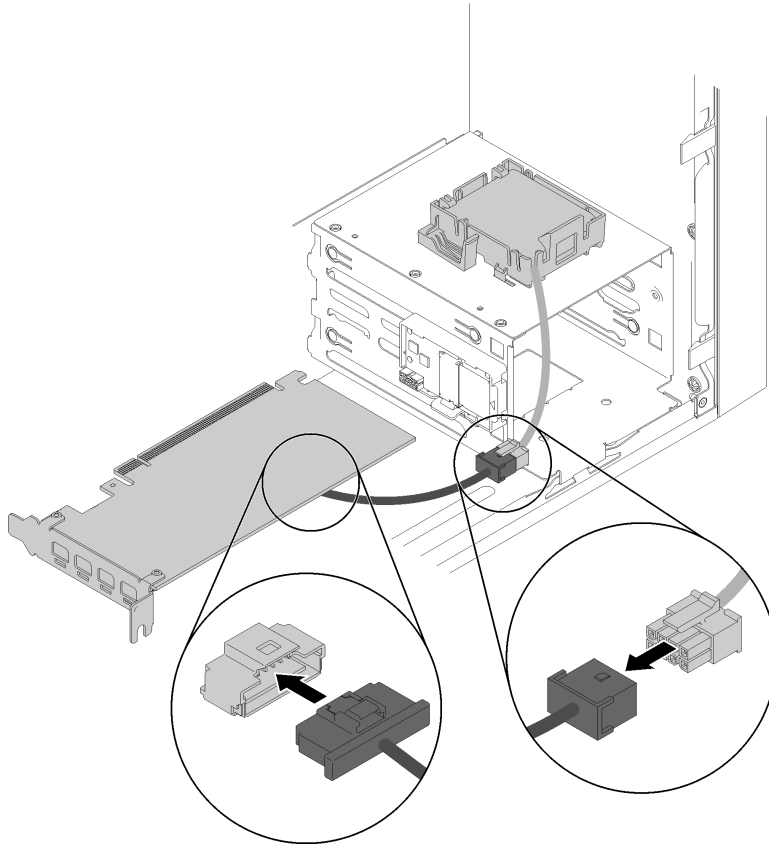

Figure 80. Connecting the flash power module cable

After installing the flash power module:



1. Install the RAID adapter (see “Install a PCIe adapter” on page 102).
2. Proceed to complete the parts replacement (see “Complete the parts replacement” on page 125).

Front bezel replacement

Follow this procedure to remove and install the front bezel.

Remove the front bezel

Follow this procedure to remove the front bezel.

 <p>“Read the installation Guidelines” on page 31</p>	 <p>“Power off the server for this task” on page 8</p>
---	--

S002

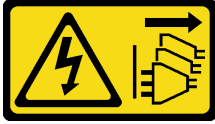

CAUTION:

The power control button on the device and the power switch on the power supply do not turn off the electrical current that is supplied to the device. The device also might have more than one power cord. To remove all electrical current from the device, ensure that all power cords are disconnected from the power source.

Before removing the front bezel:

1. Read the safety information and installation guidelines (see “Safety” on page iii and “Installation guidelines” on page 31).
2. Turn off the server and peripheral devices, and disconnect the power cords and all external cables (see “Power off the server” on page 8).
3. If the server is in a rack, remove it from the rack.
4. Remove any locking device that secures the server cover, such as a Kensington lock or a pad lock.
5. Remove the server cover (see “Remove the server cover” on page 115).

CAUTION:

The heat sinks and processor could be very hot. To avoid from burning yourself, wait for a few minutes after turning off the server before you remove the server cover.

To remove the front bezel, complete the following step:

Step 1. Release the three plastic tabs on the left side; then, pivot the front bezel as shown to remove the front bezel from the chassis.

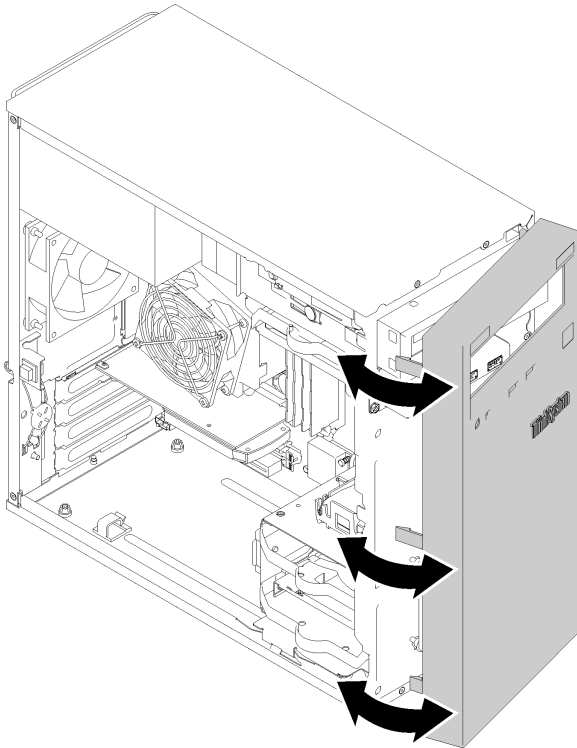



Figure 81. Removing the front bezel

After removing the front bezel:

1. If you are instructed to return the defective component, package the part to prevent any shipping damage. Reuse the packaging of the new part that arrived, and follow all available packaging instructions.

Install the front bezel

Follow this procedure to install the front bezel.

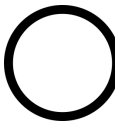
	“Read the installation Guidelines” on page 31		“Power off the server for this task” on page 8
---	--	---	---

S002



CAUTION:

The power control button on the device and the power switch on the power supply do not turn off the electrical current that is supplied to the device. The device also might have more than one power cord. To remove all electrical current from the device, ensure that all power cords are disconnected from the power source.

Before installing the front bezel:

1. Read the safety information and installation guidelines (see “Safety” on page iii and “Installation guidelines” on page 31).

To install the front bezel, complete the following step:

- Step 1. Align the three plastic tabs with the corresponding slots on the front of the chassis. Then, pivot the other side of the front bezel towards the chassis until it snaps into place.

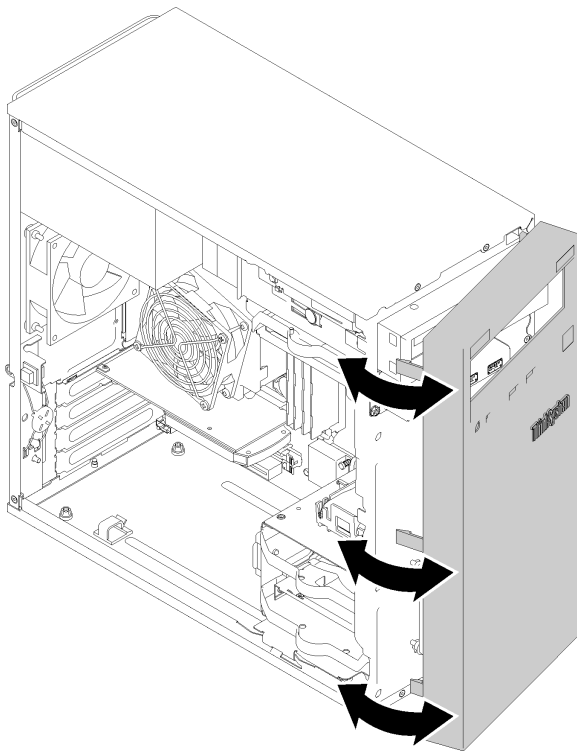

Figure 82. Front bezel installation

After installing the front bezel:



1. Proceed to complete the parts replacement (see “Complete the parts replacement” on page 125).

Front panel replacement

Follow this procedure to remove and install the front panel.

Remove the front panel

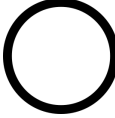
Follow this procedure to remove the front panel.

	“Read the installation Guidelines” on page 31		“Power off the server for this task” on page 8		“ATTENTION: Static Sensitive Device Ground package before opening” on page 33
---	--	---	---	--	---

S002

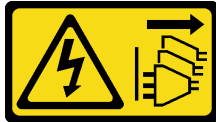

CAUTION:

The power control button on the device and the power switch on the power supply do not turn off the electrical current that is supplied to the device. The device also might have more than one power cord. To remove all electrical current from the device, ensure that all power cords are disconnected from the power source.

Before removing the front panel:

1. Read the safety information and installation guidelines (see “Safety” on page iii and “Installation guidelines” on page 31).
2. Turn off the server and peripheral devices, and disconnect the power cords and all external cables (see “Power off the server” on page 8).
3. If the server is in a rack, remove it from the rack.
4. Remove any locking device that secures the server cover, such as a Kensington lock or a pad lock.
5. Remove the server cover (see “Remove the server cover” on page 115).

CAUTION:

The heat sinks and processor could be very hot. To avoid from burning yourself, wait for a few minutes after turning off the server before you remove the server cover.

6. Remove the front bezel (see “Remove the front bezel” on page 83).

To remove the front panel, complete the following steps:

- Step 1. Disconnect all the cables from the system board.

Step 2. Remove the screw that secures the front panel to the chassis, and remove the front panel.

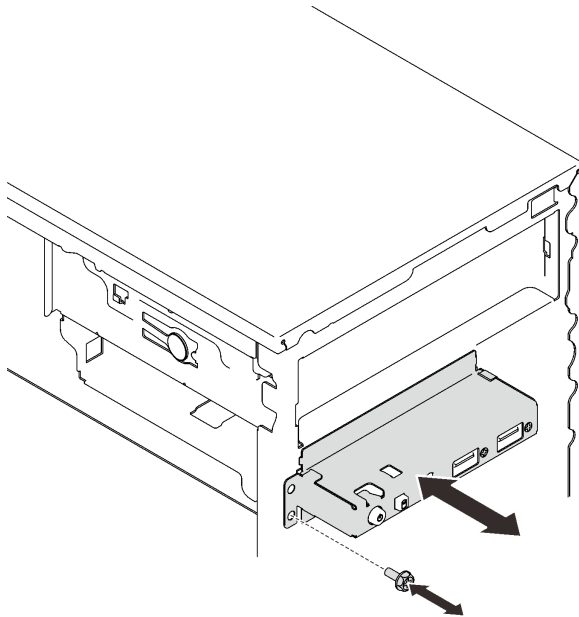



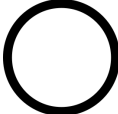

Figure 83. Removing the front panel

After removing the front panel:

1. Install a new front panel (see “Install the front panel” on page 88).
2. If you are instructed to return the defective component, package the part to prevent any shipping damage. Reuse the packaging of the new part that arrived, and follow all available packaging instructions.

Install the front panel

Follow this procedure to install the front panel.

	“Read the installation Guidelines” on page 31		“Power off the server for this task” on page 8		“ATTENTION: Static Sensitive Device” Ground package before opening” on page 33
---	---	---	--	--	---

S002



CAUTION:

The power control button on the device and the power switch on the power supply do not turn off the electrical current that is supplied to the device. The device also might have more than one power cord. To remove all electrical current from the device, ensure that all power cords are disconnected from the power source.

Before installing the front panel:

1. Touch the static-protective package that contains the component to any unpainted metal surface on the server; then, remove it from the package and place it on a static-protective surface.

To install the front panel, complete the following steps:

- Step 1. Carefully route the cables through the gap below drive bay 4.

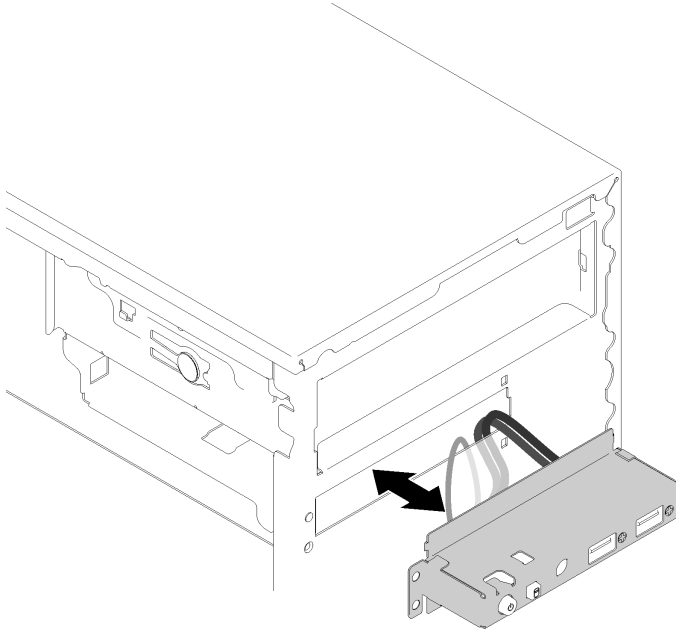

Figure 84. Routing the front panel cables

- Step 2. Align the screw hole on the front panel to the corresponding ones on the chassis; then, secure the front panel with three screws.

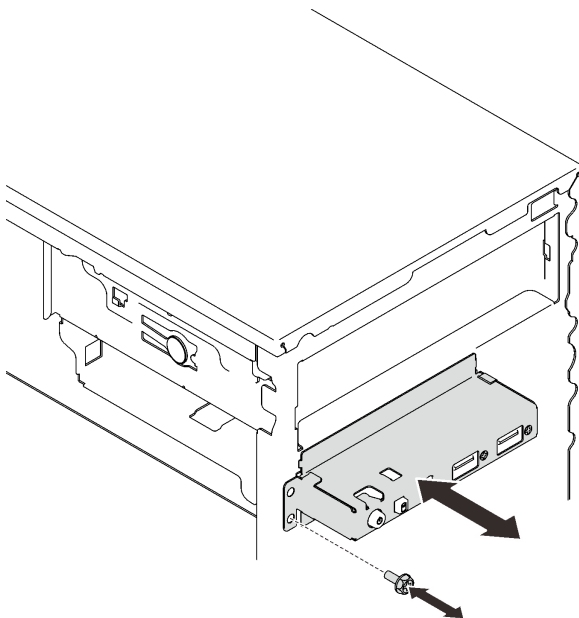

Figure 85. Installing the front panel

Step 3. Connect the front panel and USB cables to the system board. To locate the connectors on the system board, see “System board components” on page 13.

After installing the front panel:



1. Proceed to complete the parts replacement (see “Complete the parts replacement” on page 125).

Heat sink and fan module replacement

Follow this procedure to remove and install the heat sink and fan module.

Remove the heat sink and fan module

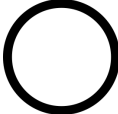
Follow this procedure to remove the heat sink and fan module. This procedure must be executed by a trained technician.

	“Read the installation Guidelines” on page 31		“Power off the server for this task” on page 8		“ATTENTION: Static Sensitive Device Ground package before opening” on page 33
---	--	---	---	--	--

S002



CAUTION:

The power control button on the device and the power switch on the power supply do not turn off the electrical current that is supplied to the device. The device also might have more than one power cord. To remove all electrical current from the device, ensure that all power cords are disconnected from the power source.

Before removing the heat sink and fan module:

1. Read the safety information and installation guidelines (see “Safety” on page iii and “Installation guidelines” on page 31).
2. Turn off the server and peripheral devices, and disconnect the power cords and all external cables (see “Power off the server” on page 8).
3. If the server is in a rack, remove it from the rack.
4. Remove any locking device that secures the server cover, such as a Kensington lock or a pad lock.
5. Remove the server cover (see “Remove the server cover” on page 115).

CAUTION:

The heat sinks and processor could be very hot. To avoid from burning yourself, wait for a few minutes after turning off the server before you remove the server cover.

6. Place the server on its side.
7. Remove the system board (see “Remove the system board (trained technician only)” on page 119).

To remove the heat sink and fan module, complete the following steps:

Step 1. Disconnect the fan cable from the system board.

Step 2. Loosen screw 1 and 2:

Notes:

1. Gently remove the four screws to avoid any possible damage to the system board.
 2. Always keep the four screws attached to the heat sink and fan module.
 3. Do not touch the thermal grease while handling the heat sink and fan module.
- a. Partially loosen screw 1.
 - b. Fully loosen screw 2.
 - c. Fully loosen screw 1.

Step 3. Loosen screw 3 and 4:

- a. Partially loosen screw 3.
- b. Fully loosen screw 4.
- c. Fully loosen screw 3.

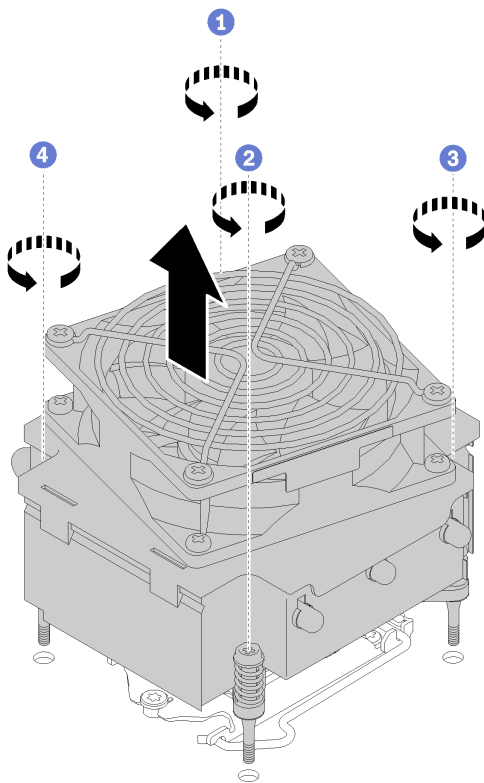

Figure 86. Removing the heat sink and fan module

Step 4. Evenly lift the heat sink and fan module, and remove it from the system board.

After removing the heat sink and fan module:

1. If you will reuse the heat sink and fan module, remove the frame from the bottom of the system board for later use.

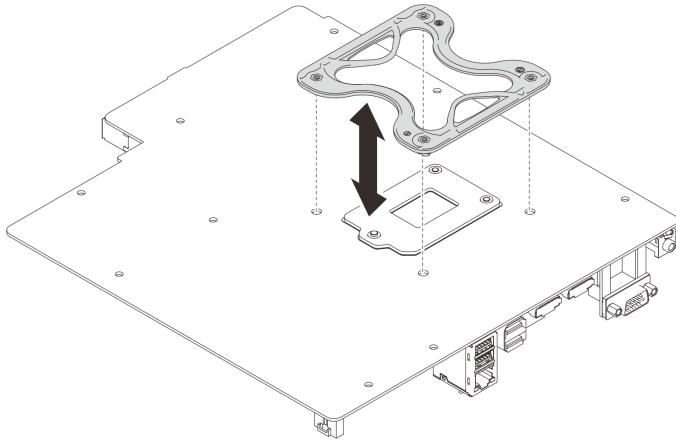
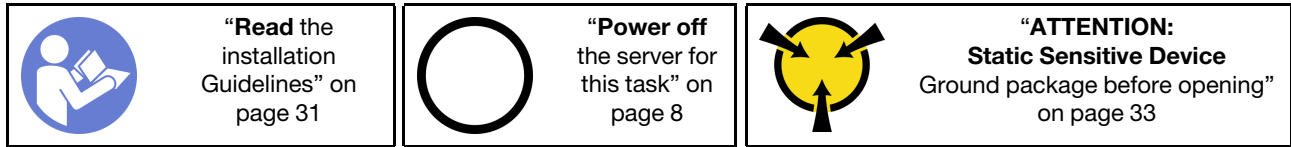

Figure 87. Removing the frame

2. If you are instructed to return the defective component, package the part to prevent any shipping damage. Reuse the packaging of the new part that arrived, and follow all available packaging instructions.

Install the heat sink and the fan module

Follow this procedure to install the heat sink and the fan module. This procedure must be executed by a trained technician.



S002

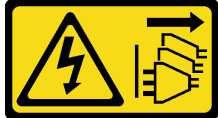

CAUTION:

The power control button on the device and the power switch on the power supply do not turn off the electrical current that is supplied to the device. The device also might have more than one power cord. To remove all electrical current from the device, ensure that all power cords are disconnected from the power source.

Before installing the heat sink and the fan module:

1. Install the processor if one is not yet installed (see “Install the processor ” on page 113).
2. If you are installing a replacement heat sink and fan module, remove the frame.

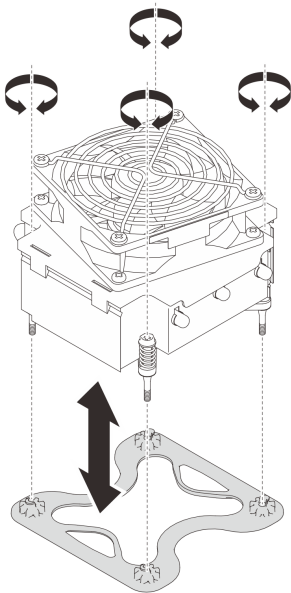

Figure 88. Removing the frame

3. Install the frame to the bottom of the system board if necessary.

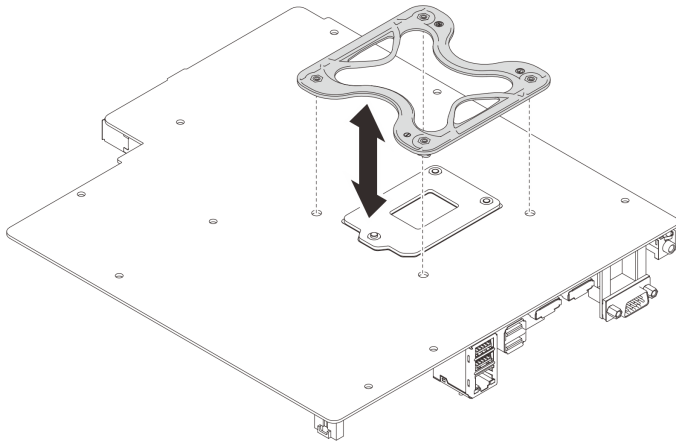

Figure 89. Installing the frame

To install the heat sink and the fan module, complete the following steps:

- Step 1. Align the four screws on the heat sink and fan assembly with the corresponding screw holes on the system board. Make sure the fan cable is close to the heat sink fan connector (See “Cable routing for the fans” on page 24).

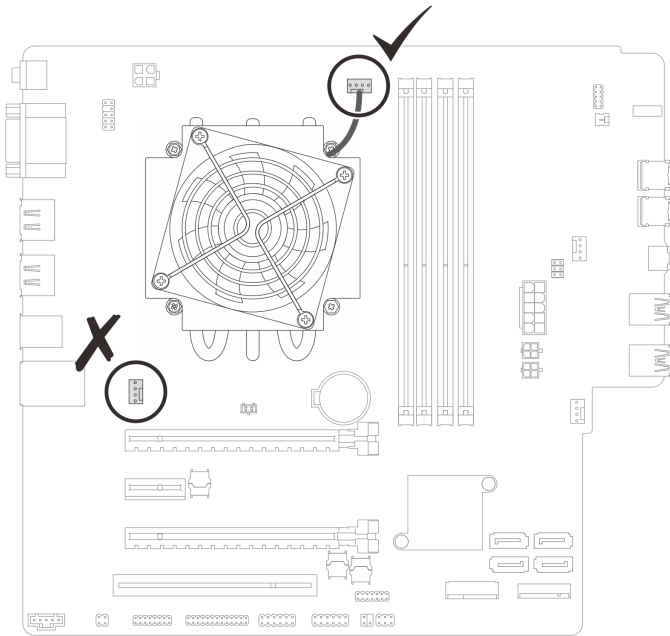

Figure 90. Aligning the heat sink and fan module

- Step 2. Tighten screw 1 and 2:
- Partially tighten screw 1.
 - Fully tighten screw 2.
 - Fully tighten screw 1.

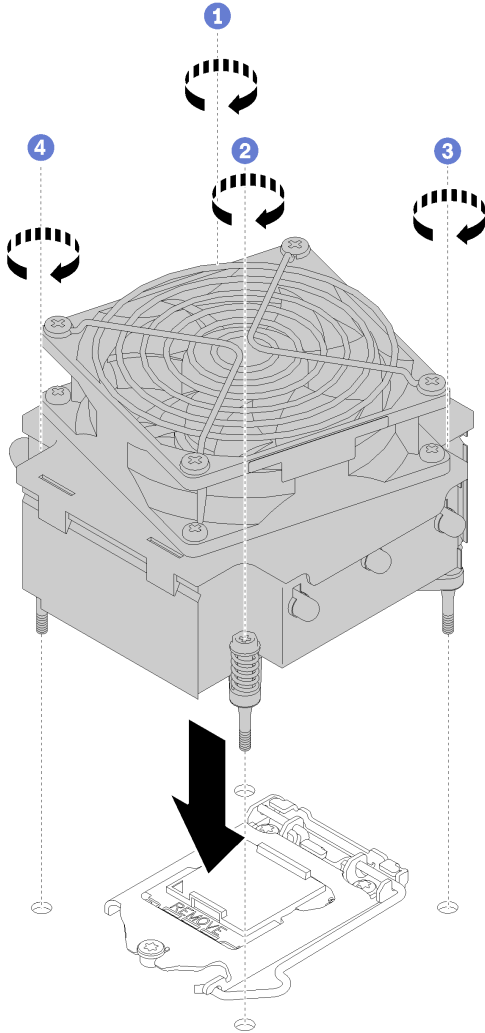

Figure 91. Installing the heat sink and the fan module

- Step 3. Tighten screw 3 and 4:
- Partially tighten screw 3.
 - Fully tighten screw 4.
 - Fully tighten screw 3.

Step 4. Connect the fan cable to the system board.

After installing the heat sink and the fan module:



- Install the system board (see “Install the system board (trained technician only)” on page 121).
- Proceed to complete the parts replacement (see “Complete the parts replacement” on page 125).

Intrusion switch replacement

The intrusion switch generates an event in the system event log (SEL) when the server cover is not properly installed. Follow this procedure to remove and install the intrusion switch.

Remove the intrusion switch

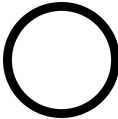
Follow this procedure to remove the intrusion switch.

 <p>“Read the installation Guidelines” on page 31</p>	 <p>“Power off the server for this task” on page 8</p>	 <p>“ATTENTION: Static Sensitive Device Ground package before opening” on page 33</p>
--	---	---

S002



CAUTION:

The power control button on the device and the power switch on the power supply do not turn off the electrical current that is supplied to the device. The device also might have more than one power cord. To remove all electrical current from the device, ensure that all power cords are disconnected from the power source.

Before removing the intrusion switch:

1. Read the safety information and installation guidelines (see “Safety” on page iii and “Installation guidelines” on page 31).
2. Turn off the server and peripheral devices, and disconnect the power cords and all external cables (see “Power off the server” on page 8).
3. If the server is in a rack, remove it from the rack.
4. Remove any locking device that secures the server cover, such as a Kensington lock or a pad lock.
5. Remove the server cover (see “Remove the server cover” on page 115).

CAUTION:

The heat sinks and processor could be very hot. To avoid from burning yourself, wait for a few minutes after turning off the server before you remove the server cover.

To remove the intrusion switch, complete the following steps:

Step 1. Disconnect the intrusion switch cable from the system board.

Step 2. Remove the screw that secures the intrusion switch, and remove the intrusion switch from the chassis.

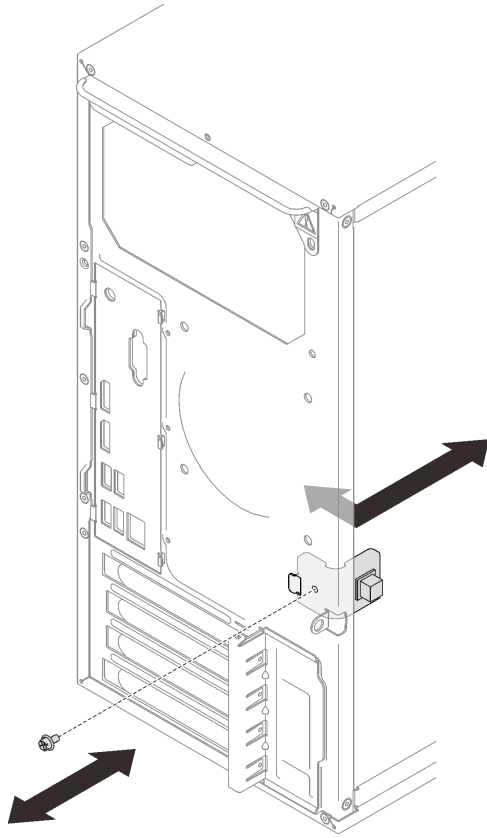



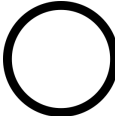

Figure 92. Removing the intrusion switch

After removing the intrusion switch:

1. Install a new intrusion switch (see “Install the intrusion switch” on page 97).
2. If you are instructed to return the defective component, package the part to prevent any shipping damage. Reuse the packaging of the new part that arrived, and follow all available packaging instructions.

Install the intrusion switch

Follow this procedure to install the intrusion switch.

	“Read the installation Guidelines” on page 31		“Power off the server for this task” on page 8		“ATTENTION: Static Sensitive Device Ground package before opening” on page 33
---	--	---	---	--	--

S002



CAUTION:

The power control button on the device and the power switch on the power supply do not turn off the electrical current that is supplied to the device. The device also might have more than one power cord. To remove all electrical current from the device, ensure that all power cords are disconnected from the power source.

Before installing the intrusion switch:

1. Touch the static-protective package that contains the component to any unpainted metal surface on the server; then, remove it from the package and place it on a static-protective surface.

To install the intrusion switch, complete the following steps:

- Step 1. Align the intrusion switch to the chassis as illustrated; then, secure it with a screw.

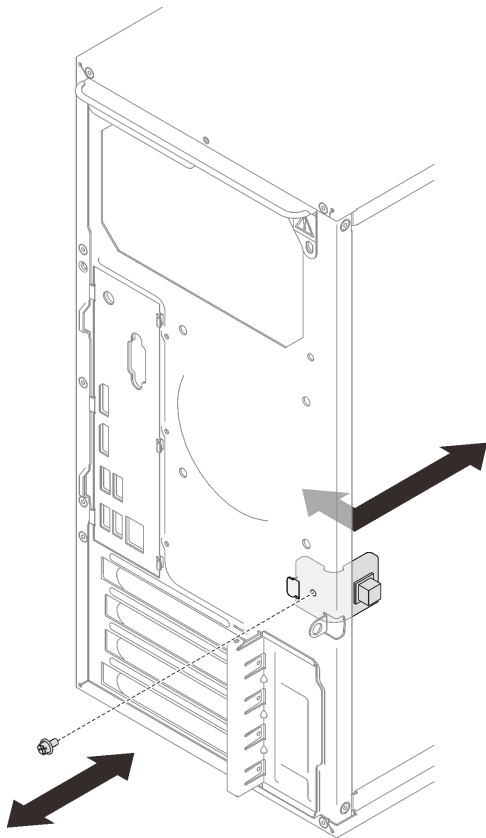

Figure 93. Installing the intrusion switch

- Step 2. Connect the intrusion switch cable to the system board. To locate the connector on the system board, see “System board components” on page 13.

After installing the intrusion switch:

1. Proceed to complete the parts replacement (see “Complete the parts replacement” on page 125).

PCIe adapter replacement

Follow this procedure to remove and install a PCIe adapter.

This server comes with three PCIe slots. The adapter can be Ethernet, host bus, RAID, graphics, or any other types that are supported, but the installation and removal procedures are the same.

Note: For a list of the supported PCIe adapters, see:

<http://www.lenovo.com/us/en/serverproven/>

Remove a PCIe adapter

Follow this procedure to remove a PCIe adapter.

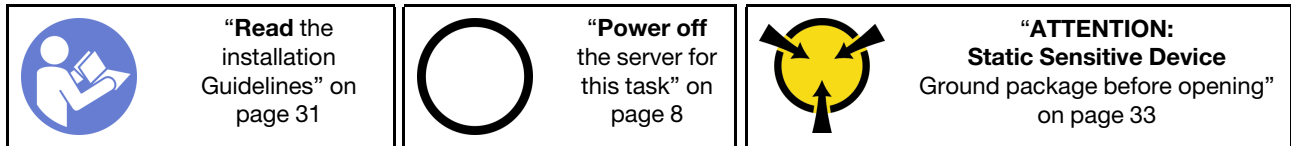

S002



CAUTION:

The power control button on the device and the power switch on the power supply do not turn off the electrical current that is supplied to the device. The device also might have more than one power cord. To remove all electrical current from the device, ensure that all power cords are disconnected from the power source.

Before removing a PCIe adapter:

1. Read the safety information and installation guidelines (see “Safety” on page iii and “Installation guidelines” on page 31).
2. Turn off the server and peripheral devices, and disconnect the power cords and all external cables (see “Power off the server” on page 8).
3. If the server is in a rack, remove it from the rack.
4. Remove any locking device that secures the server cover, such as a Kensington lock or a pad lock.
5. Remove the server cover (see “Remove the server cover” on page 115).

CAUTION:

The heat sinks and processor could be very hot. To avoid from burning yourself, wait for a few minutes after turning off the server before you remove the server cover.

6. Remove the heat sink and fan module (see “Remove the heat sink and fan module” on page 90).
7. Press the release button on the rear of the server to open the PCIe adapter retainer.

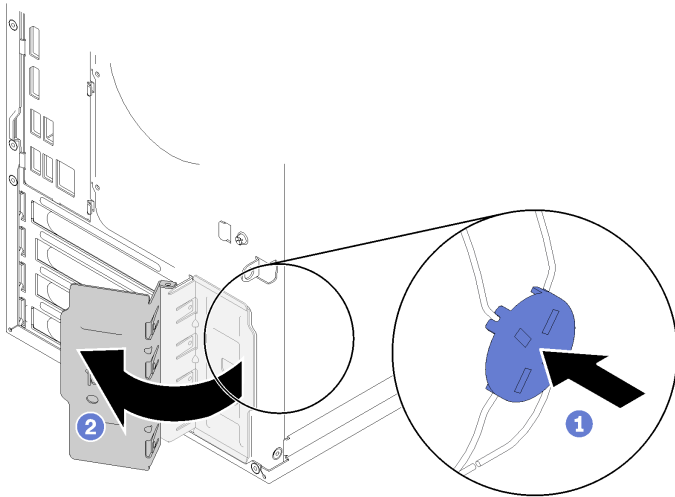

Figure 94. Opening the PCIe adapter retainer

8. Place the server on its side.

Notes:

- The PCIe adapter might look different from the illustration.
- Make sure to read the documentation that comes with the PCIe adapter, and follow the instructions.

To remove a PCIe adapter, complete the following steps:

Step 1. Press on the retaining clip on the side of the PCIe slot to open it.

Step 2. Grasp the PCIe adapter by both edges, and gently lift it out from the PCIe slot.

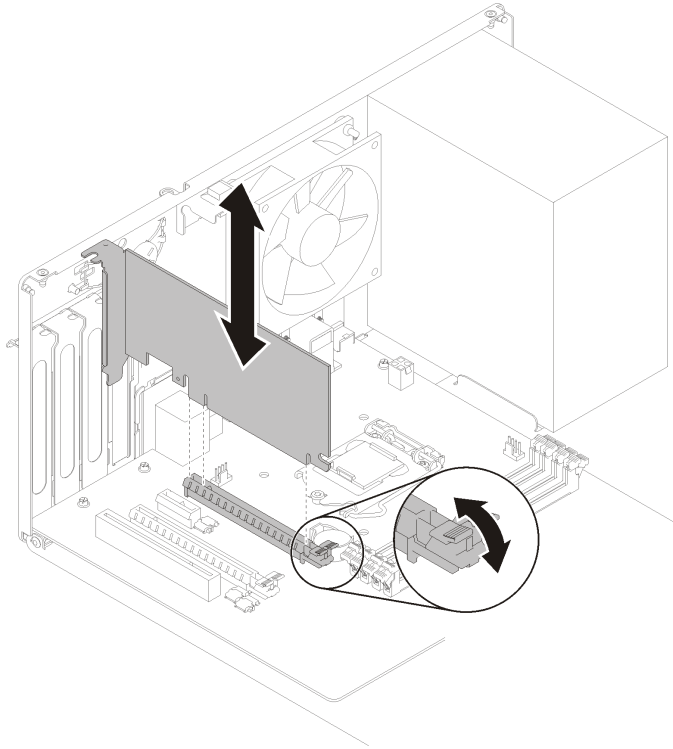

Figure 95. Removing a PCIe adapter

Note: The PCIe adapter might be clamped by the slot tightly. In this case, gently and evenly shake the PCIe adapter until the clamping force from the connector is significantly reduced and the adapter becomes easily removable.

After removing a PCIe adapter:

1. Install another PCIe adapter if necessary (see “Install a PCIe adapter” on page 102). Otherwise, install a bracket to cover the vacancy on the chassis, and close the retainer.

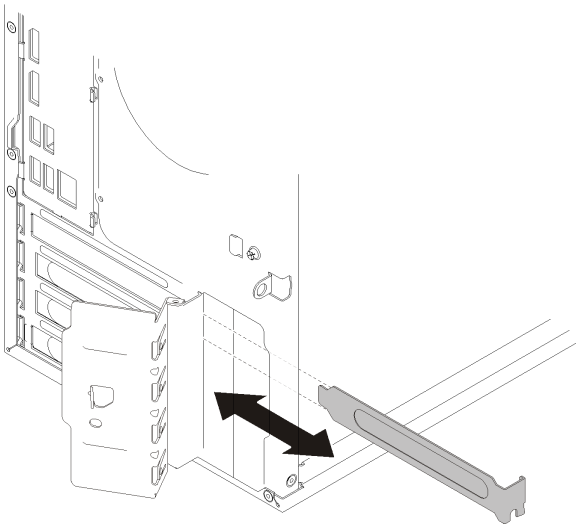

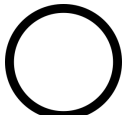



Figure 96. Installing a PCIe adapter bracket

2. If you are instructed to return the defective component, package the part to prevent any shipping damage. Reuse the packaging of the new part that arrived, and follow all available packaging instructions.

Install a PCIe adapter

Follow this procedure to install a PCIe adapter.

	“Read the installation Guidelines” on page 31		“Power off the server for this task” on page 8		“ATTENTION: Static Sensitive Device Ground package before opening” on page 33
---	--	---	---	--	--

S002



CAUTION:

The power control button on the device and the power switch on the power supply do not turn off the electrical current that is supplied to the device. The device also might have more than one power cord. To remove all electrical current from the device, ensure that all power cords are disconnected from the power source.

Notes:

- The PCIe adapter might look different from the illustration.
- Make sure to read the documentation that comes with the PCIe adapter, and follow the instructions.

Before installing a PCIe adapter:

1. Make sure the PCIe adapter retainer is in the open position. If not, press the release button on the rear of the chassis to open it.

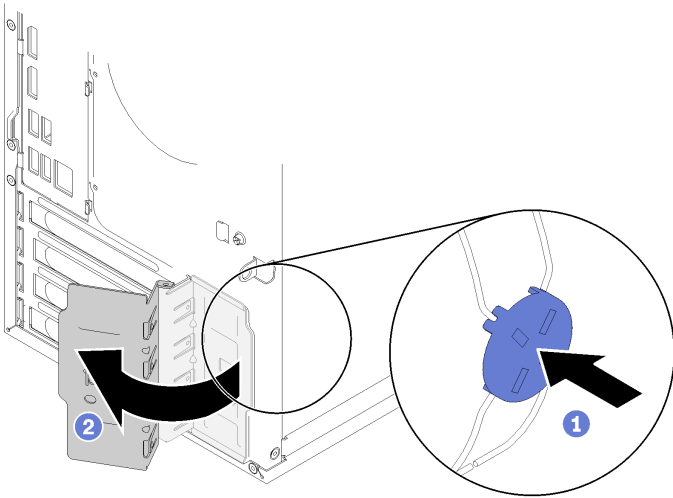

Figure 97. Opening the PCIe adapter retainer

2. If a bracket lies in place, remove it and keep it for future use.

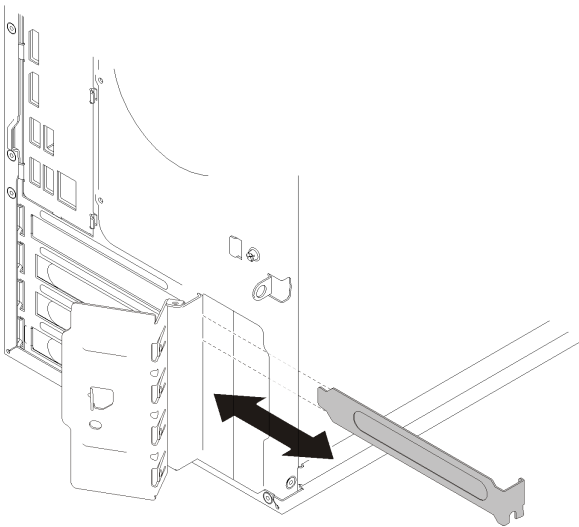

Figure 98. Removing a PCIe adapter bracket

3. Place the server on its side.
4. Touch the static-protective package that contains the component to any unpainted metal surface on the server; then, remove it from the package and place it on a static-protective surface.

To install a PCIe adapter, complete the following steps:

- Step 1. Locate the applicable PCIe slot. For more information about the PCIe slots, see “Specifications” on page 4.
- Step 2. If the retaining clip on the side of the PCIe slot is closed, press on it to open it.

Step 3. Align the PCIe adapter to the slot; then, gently press both ends of the PCIe adapter until it is securely seated in the slot with the retaining clip clicks into the locked position.

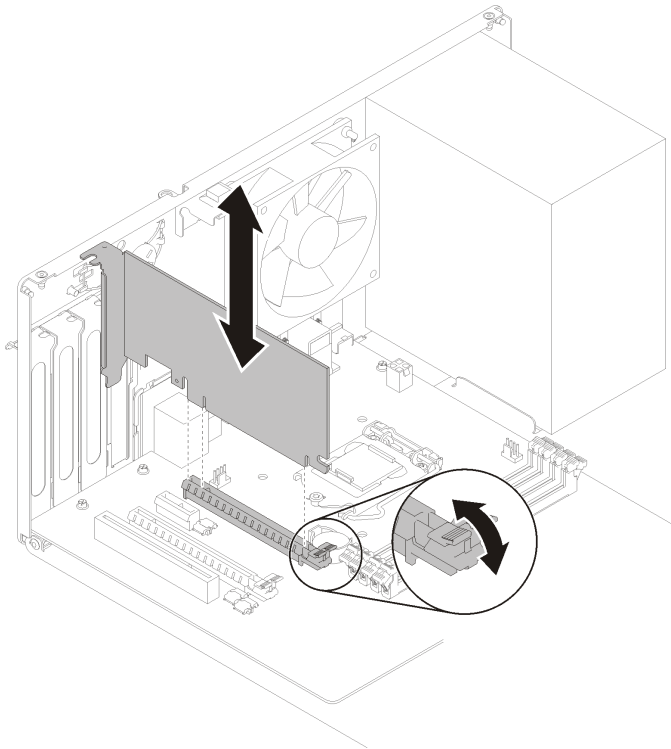
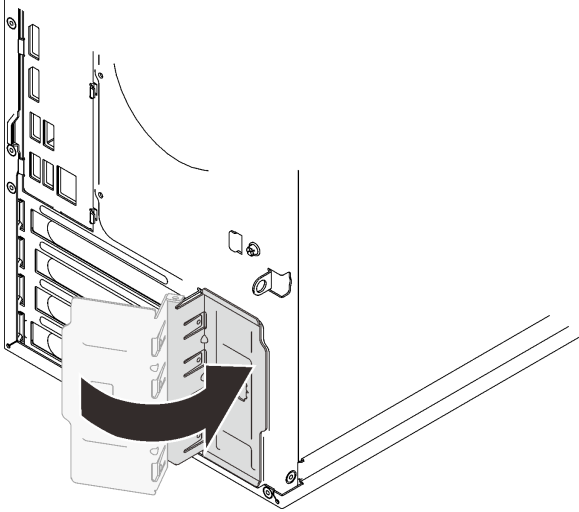

Figure 99. Installing the PCIe adapter

After installing the PCIe adapter:

1. Depending on the type of the PCIe adapter, you might need to connect one or more cables. For more information, read the documentation that comes with the PCIe adapter.
2. To secure the installed adapter, pivot the retainer towards the chassis until it snaps into the locked position.

Figure 100. Closing the PCIe adapter retainer



3. Proceed to complete the parts replacement (see “Complete the parts replacement” on page 125).

Power supply unit replacement



Follow this procedure to remove and install the fixed power supply unit.

This server supports one unit of fixed power supply of the following types:

- 250-watt
- 400-watt

Remove the power supply unit

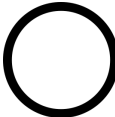
Follow this procedure to remove the power supply unit.

 <p>“Read the installation Guidelines” on page 31</p>	 <p>“Power off the server for this task” on page 8</p>	 <p>“ATTENTION: Static Sensitive Device Ground package before opening” on page 33</p>
--	---	---

S002

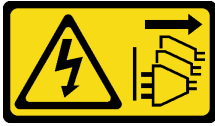

CAUTION:

The power control button on the device and the power switch on the power supply do not turn off the electrical current that is supplied to the device. The device also might have more than one power cord. To remove all electrical current from the device, ensure that all power cords are disconnected from the power source.

S029



**Electrical current from power, telephone, and communication cables is hazardous.
To avoid a shock hazard:**

- Do not connect or disconnect any cables or perform installation, maintenance, or reconfiguration of this product during an electrical storm.
- Connect all power cords to a properly wired and grounded power source.
- Connect to properly wired power sources any equipment that will be attached to this product.
- When possible, use one hand only to connect or disconnect signal cables.
- Never turn on any equipment when there is evidence of fire, water, or structural damage.
- Disconnect the attached ac power cords, dc power sources, network connections, telecommunications systems, and serial cables before you open the device covers, unless you are instructed otherwise in the installation and configuration procedures.
- Connect and disconnect cables as described in the following table when you install, move, or open covers on this product or attached devices.

To Connect:

1. Turn OFF all power sources and equipment that is to be attached to this product.
2. Attach signal cables to the product.
3. Attach power cords to the product.
 - For ac systems, use appliance inlets.
 - For dc systems, ensure correct polarity of -48 V dc connections: RTN is + and -48 V dc is -. Earth ground should use a two-hole lug for safety.
4. Attach signal cables to other devices.
5. Connect power cords to their sources.
6. Turn ON all the power sources.

To Disconnect:

1. Turn OFF all power sources and equipment that is to be attached to this product.
 - For ac systems, remove all power cords from the chassis power receptacles or interrupt power at the ac power distribution unit.
 - For dc systems, disconnect dc power sources at the breaker panel or by turning off the power source. Then, remove the dc cables.
2. Remove the signal cables from the connectors.
3. Remove all cables from the devices.

S035

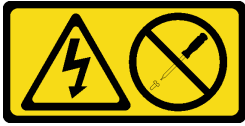

CAUTION:

Never remove the cover on a power supply or any part that has this label attached. Hazardous voltage, current, and energy levels are present inside any component that has this label attached. There are no serviceable parts inside these components. If you suspect a problem with one of these parts, contact a service technician.

Before removing the power supply unit:

1. Read the safety information and installation guidelines (see “Safety” on page iii and “Installation guidelines” on page 31).
2. Turn off the server and peripheral devices, and disconnect the power cords and all external cables (see “Power off the server” on page 8).
3. If the server is in a rack, remove it from the rack.
4. Remove any locking device that secures the server cover, such as a Kensington lock or a pad lock.
5. Remove the server cover (see “Remove the server cover” on page 115).

CAUTION:

The heat sinks and processor could be very hot. To avoid from burning yourself, wait for a few minutes after turning off the server before you remove the server cover.

6. Place the server on its side.

To remove the power supply unit, complete the following steps:

- Step 1. Disconnect both cables from the system board.
- Step 2. Remove the four screws that secure the power supply unit.

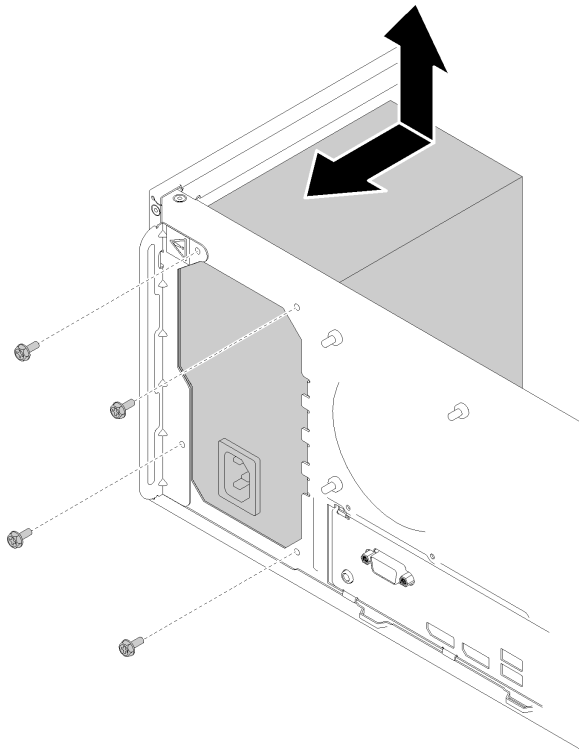

Figure 101. Removing the power supply unit

Step 3. Gently push the power supply unit towards the front of the server, and remove it from the chassis.

After removing the power supply unit:

1. Install another power supply unit (see “Install the power supply unit” on page 108).
2. If you are instructed to return the defective component, package the part to prevent any shipping damage. Reuse the packaging of the new part that arrived, and follow all available packaging instructions.

Install the power supply unit

Follow this procedure to install the power supply unit.

S002



CAUTION:

The power control button on the device and the power switch on the power supply do not turn off the electrical current that is supplied to the device. The device also might have more than one power cord. To remove all electrical current from the device, ensure that all power cords are disconnected from the power source.

S029



 **DANGER**

Electrical current from power, telephone, and communication cables is hazardous.

To avoid a shock hazard:

- **Do not connect or disconnect any cables or perform installation, maintenance, or reconfiguration of this product during an electrical storm.**
- **Connect all power cords to a properly wired and grounded power source.**
- **Connect to properly wired power sources any equipment that will be attached to this product.**
- **When possible, use one hand only to connect or disconnect signal cables.**
- **Never turn on any equipment when there is evidence of fire, water, or structural damage.**
- **Disconnect the attached ac power cords, dc power sources, network connections, telecommunications systems, and serial cables before you open the device covers, unless you are instructed otherwise in the installation and configuration procedures.**
- **Connect and disconnect cables as described in the following table when you install, move, or open covers on this product or attached devices.**

To Connect:

1. Turn OFF all power sources and equipment that is to be attached to this product.
2. Attach signal cables to the product.
3. Attach power cords to the product.
 - For ac systems, use appliance inlets.
 - For dc systems, ensure correct polarity of -48 V dc connections: RTN is + and -48 V dc is -. Earth ground should use a two-hole lug for safety.
4. Attach signal cables to other devices.
5. Connect power cords to their sources.
6. Turn ON all the power sources.

To Disconnect:

1. Turn OFF all power sources and equipment that is to be attached to this product.
 - For ac systems, remove all power cords from the chassis power receptacles or interrupt power at the ac power distribution unit.
 - For dc systems, disconnect dc power sources at the breaker panel or by turning off the power source. Then, remove the dc cables.
2. Remove the signal cables from the connectors.
3. Remove all cables from the devices.

S035



CAUTION:

Never remove the cover on a power supply or any part that has this label attached. Hazardous voltage, current, and energy levels are present inside any component that has this label attached. There are no serviceable parts inside these components. If you suspect a problem with one of these parts, contact a service technician.

Before installing the power supply unit,

1. Make sure the type of power supply is applicable to server drive configuration.
2. Touch the static-protective package that contains the component to any unpainted metal surface on the server; then, remove it from the package and place it on a static-protective surface.

To install the power supply unit, complete the following steps:

- Step 1. Align the four screw holes on the power supply units with the corresponding ones on the chassis; then, secure the power supply with four screws.

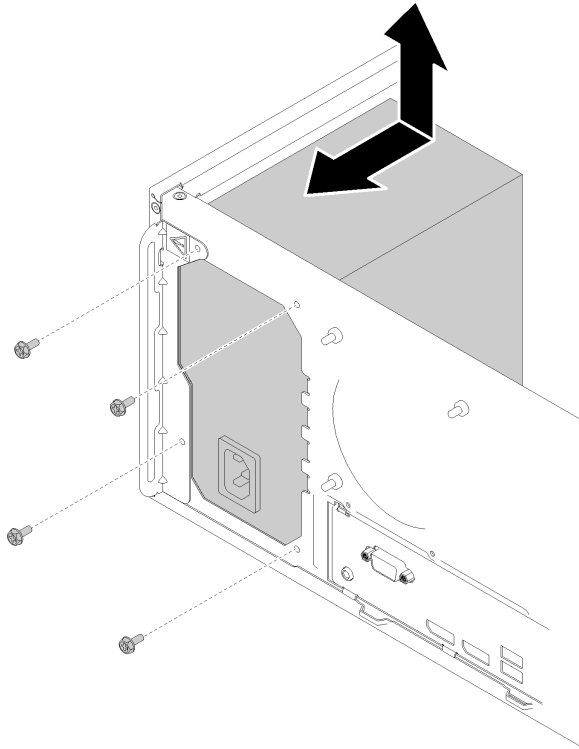

Figure 102. Installing the power supply unit

Step 2. Connect the processor and system power cables to the system board.

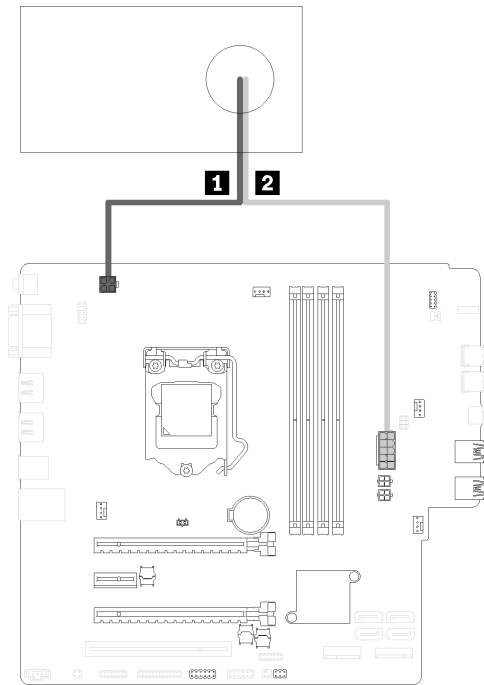

Figure 103. Connecting power supply cables

Table 27. Power supply cables

1 To processor power connector (four-pin)	2 To system power connector (ten-pin)
--	--

After installing the power supply unit:

1. Proceed to complete the parts replacement (see “Complete the parts replacement” on page 125).

Processor replacement

Use the following procedures to remove and install a processor.

Attention: Before you begin replacing a processor, make sure that you have an alcohol cleaning pad (part number 00MP352) and gray thermal grease (part number 41Y9292).

Remove the processor

Follow this procedure to remove the processor. This procedure must be executed by a trained technician.

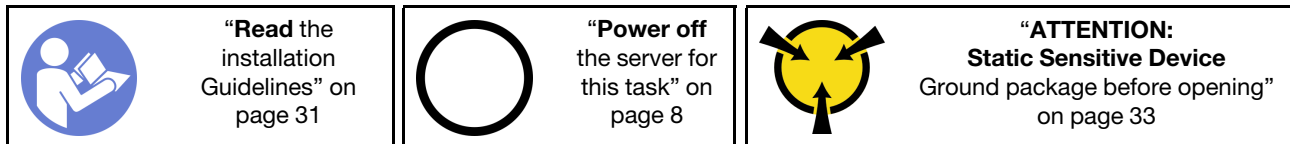

S002



CAUTION:

The power control button on the device and the power switch on the power supply do not turn off the electrical current that is supplied to the device. The device also might have more than one power cord. To remove all electrical current from the device, ensure that all power cords are disconnected from the power source.

Before removing the processor:

1. Read the safety information and installation guidelines (see “Safety” on page iii and “Installation guidelines” on page 31).
2. Turn off the server and peripheral devices, and disconnect the power cords and all external cables (see “Power off the server” on page 8).
3. If the server is in a rack, remove it from the rack.
4. Remove any locking device that secures the server cover, such as a Kensington lock or a pad lock.
5. Remove the server cover (see “Remove the server cover” on page 115).

CAUTION:

The heat sinks and processor could be very hot. To avoid from burning yourself, wait for a few minutes after turning off the server before you remove the server cover.

6. Place the server on its side.
7. Remove the system board (see “Remove the system board (trained technician only)” on page 119).
8. Remove the heat sink and fan module (see “Remove the heat sink and fan module” on page 90).

To remove the processor, complete the following steps:

Step 1. Gently pull the handle away from the processor retainer.

Step 2. Lift the handle along with the retainer to the fully open position.

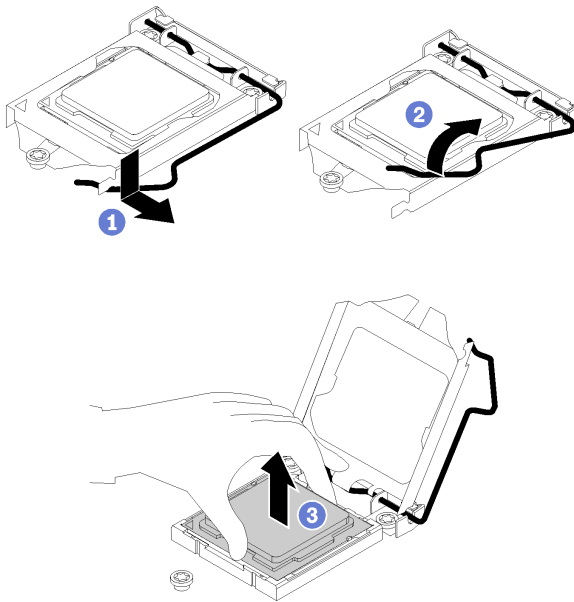

Figure 104. Opening the processor retainer

Step 3. Hold the processor by both sides and gently lift it away from the processor socket.

Notes:



1. Do not touch the gold contacts on the bottom of the processor.
2. Keep the processor socket clean from any object to prevent possible damages.

After removing the processor, perform one of the following tasks immediately:

- Install the replacement processor.
 1. Install the replacement processor to the system board (see “Install the processor ” on page 113).
 2. Package the defective processor that was removed, and return it to Lenovo. To prevent any shipping damage, reuse the packaging of the new processor, and follow all available packaging instructions.or
- Install the processor that you removed to the replacement system board.
 1. Install the removed processor to the replacement system board (see “Install the processor ” on page 113).
 2. Package the defective system board, and return it to Lenovo. To prevent any shipping damage, reuse the packaging of the new system board, and follow all available packaging instructions.

Install the processor

Follow this procedure to install the processor. This procedure must be executed by a trained technician.

	“Read the installation Guidelines” on page 31		“Power off the server for this task” on page 8		“ATTENTION: Static Sensitive Device Ground package before opening” on page 33
---	--	---	---	--	--

S002

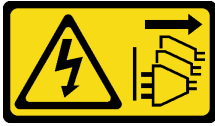

CAUTION:

The power control button on the device and the power switch on the power supply do not turn off the electrical current that is supplied to the device. The device also might have more than one power cord. To remove all electrical current from the device, ensure that all power cords are disconnected from the power source.

Before installing the processor:

1. Before reusing a processor that was removed from another system board, wipe the thermal grease from the processor with an alcohol cleaning pad, and dispose of the cleaning pad after all of the thermal grease is removed.

Note: If you are applying new thermal grease on the top of the processor, make sure to do it after the alcohol has fully evaporated.

2. Apply the thermal grease on the top of the processor with syringe by forming four uniformly spaced dots, while each dot consists of about 0.1 ml of thermal grease.

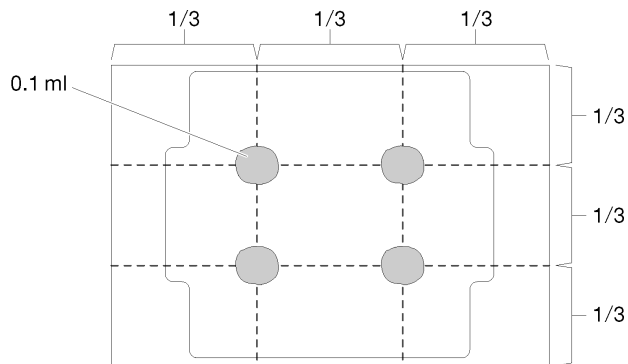

Figure 105. Proper shape of the thermal grease

To install the processor, complete the following steps:

Step 1. Hold the processor by both sides, and align the following:

1. Align **1** the small notches on the processor to **2** the tabs on the socket.
2. Align **3** the small triangle of the processor to **4** the beveled corner on the socket.

Then, gently lower the processor evenly into the socket.

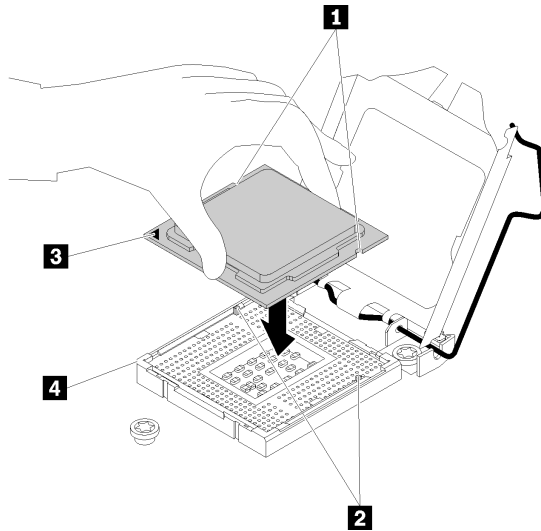

Figure 106. Installing the processor

Step 2. Close the processor retainer, and push the handle to the locked position.

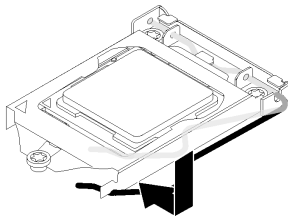

Figure 107. Closing the processor retainer

After installing the processor:



1. Install the heat sink and fan assembly (see “Install the heat sink and the fan module” on page 93).
2. Install the system board (see “Install the system board (trained technician only)” on page 121).
3. Proceed to complete the parts replacement (see “Complete the parts replacement” on page 125).

Server cover replacement

Follow this procedure to remove and install the server cover.

Remove the server cover

Follow this procedure to remove the server cover.

 <p>“Read the installation Guidelines” on page 31</p>	 <p>“Power off the server for this task” on page 8</p>	 <p>“ATTENTION: Static Sensitive Device Ground package before opening” on page 33</p>
--	---	---

S002

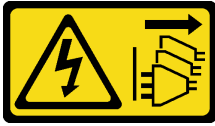

CAUTION:

The power control button on the device and the power switch on the power supply do not turn off the electrical current that is supplied to the device. The device also might have more than one power cord. To remove all electrical current from the device, ensure that all power cords are disconnected from the power source.

Before removing the server cover:

1. Read the safety information and installation guidelines (see “Safety” on page iii and “Installation guidelines” on page 31).
2. Turn off the server and peripheral devices, and disconnect the power cords and all external cables (see “Power off the server” on page 8).
3. If the server is in a rack, remove it from the rack.
4. Remove any locking device that secures the server cover, such as a Kensington lock or a pad lock.

Complete the following steps to remove the server cover:

Step 1. Remove the two screws that secure the cover to the chassis.

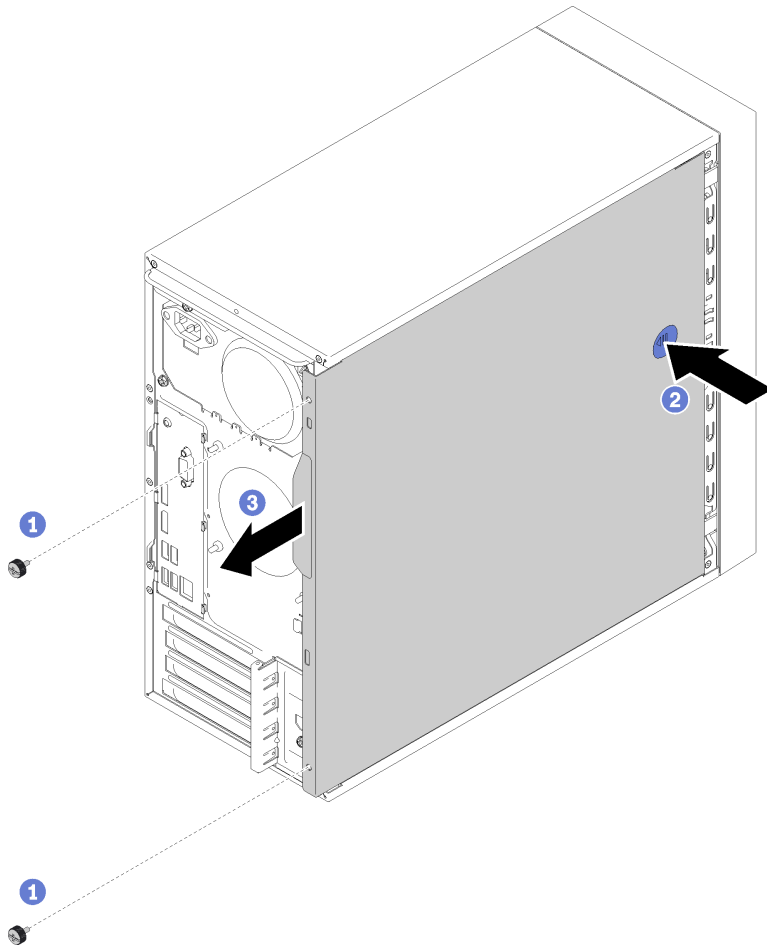

Figure 108. Removing the server cover

Step 2. Press and hold on the release button, and slide the cover towards the rear of the server to remove it.



Attention: For proper cooling, always install the server cover before powering on the server. Operating the server without the cover properly installed might result in server component damage.

After removing the server cover:

1. If you are instructed to return the defective component, package the part to prevent any shipping damage. Reuse the packaging of the new part that arrived, and follow all available packaging instructions.

Install the server cover

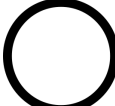
Follow this procedure to install the server cover.

	“Read the installation Guidelines” on page 31		“Power off the server for this task” on page 8		“ATTENTION: Static Sensitive Device Ground package before opening” on page 33
---	--	---	---	--	--

S002

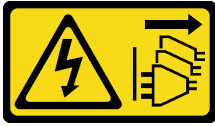

CAUTION:

The power control button on the device and the power switch on the power supply do not turn off the electrical current that is supplied to the device. The device also might have more than one power cord. To remove all electrical current from the device, ensure that all power cords are disconnected from the power source.

Before installing the server cover:

1. Ensure that all adapters and other components are installed and seated correctly, and that you have not left loose tools or parts inside the server.
2. Ensure that all internal cables are correctly routed. See “Internal cable routing” on page 15.
3. If you are installing a new server cover, attach the service label to the inside of the new server cover if necessary.

Note: A new server cover comes without a service label attached. If you need a service label, order it together with the new server cover. The service label is free of charge.

To install the server cover, complete the following steps:

Step 1. Align the server cover to the slots on the side of the chassis, and slide it towards the front of the chassis until it snaps in place.

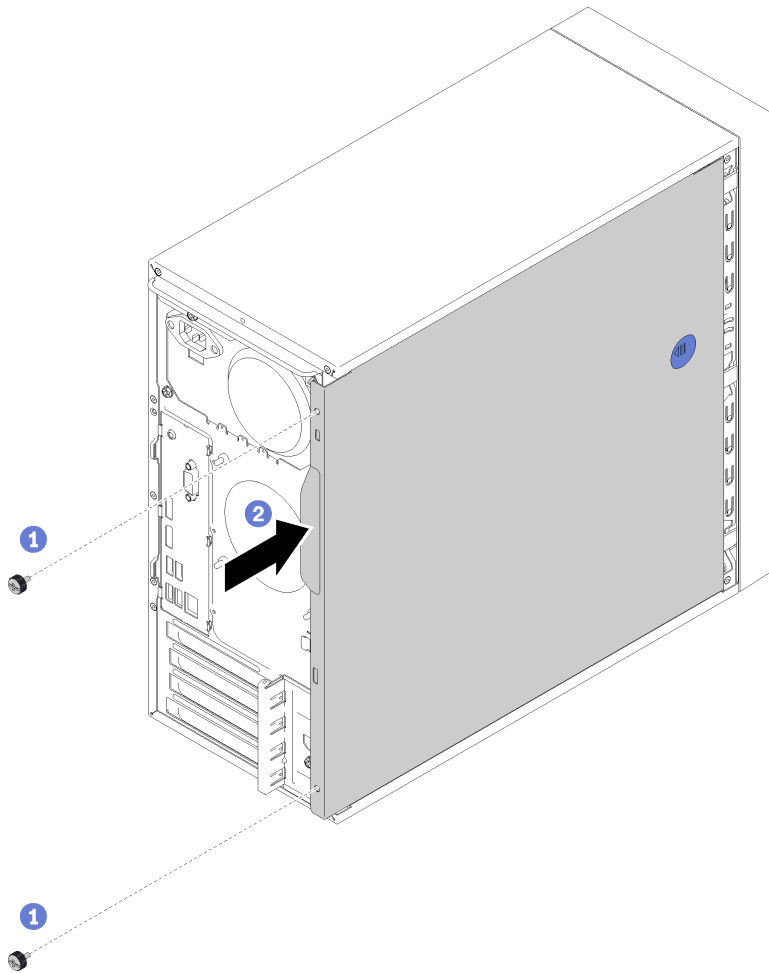

Figure 109. Installing the server cover

Note: Before sliding the cover in, ensure that all the tabs on the cover align to the slots and engage the chassis properly.

Step 2. Secure the cover to the chassis with two screws.

After installing the server cover:

1. Proceed to complete the parts replacement (see “Complete the parts replacement” on page 125).

System board replacement

Follow this procedure to remove and install the system board.

Remove the system board (trained technician only)

Follow this procedure to remove the system board. This procedure must be executed by a trained technician.

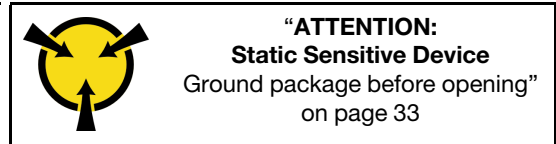
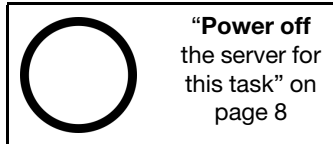

S002

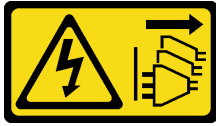

CAUTION:

The power control button on the device and the power switch on the power supply do not turn off the electrical current that is supplied to the device. The device also might have more than one power cord. To remove all electrical current from the device, ensure that all power cords are disconnected from the power source.

Before removing the system board:

1. Read the safety information and installation guidelines (see “Safety” on page iii and “Installation guidelines” on page 31).
2. Turn off the server and peripheral devices, and disconnect the power cords and all external cables (see “Power off the server” on page 8).
3. If the server is in a rack, remove it from the rack.
4. Remove any locking device that secures the server cover, such as a Kensington lock or a pad lock.
5. Remove the server cover (see “Remove the server cover” on page 115).

CAUTION:

The heat sinks and processor could be very hot. To avoid from burning yourself, wait for a few minutes after turning off the server before you remove the server cover.

6. Place the server on its side.
7. Disconnect all the cables connected to the system board.

Attention: Disengage all latches, cable clips, release tabs, or locks on cable connectors beforehand. Failing to release them before removing the cables will damage the cable connectors on the system board. Any damage to the cable connectors may require system board replacement.

8. Remove all the PCIe adapters (see “Remove a PCIe adapter” on page 99).
9. Remove all the DIMMs (see “Remove a DIMM” on page 37).

To remove the system board, complete the following steps:

- Step 1. Remove the eight screws that secure the system board in the order as illustrated, and keep them for future use.

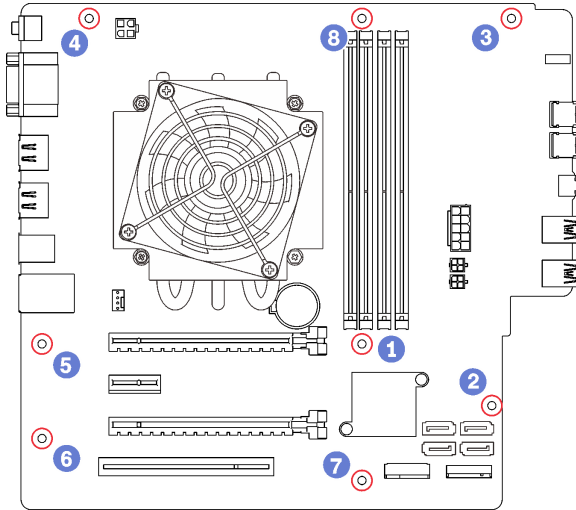

Figure 110. System board screw removal sequence



Step 2. Gently grasp the system board by the edges and remove it from the chassis.

After removing the system board:

1. Remove the heat sink and fan module and the processor if necessary (see “Remove the heat sink and fan module” on page 90 and “Remove the processor” on page 112).
2. Install another system board (see “Install the system board (trained technician only)” on page 121).
3. If you are instructed to return the defective component, package the part to prevent any shipping damage. Reuse the packaging of the new part that arrived, and follow all available packaging instructions.

Install the system board (trained technician only)

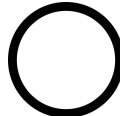
Follow this procedure to install the system board. This procedure must be executed by a trained technician.

 <p>“Read the installation Guidelines” on page 31</p>	 <p>“Power off the server for this task” on page 8</p>	 <p>“ATTENTION: Static Sensitive Device Ground package before opening” on page 33</p>
--	---	---

S002



CAUTION:

The power control button on the device and the power switch on the power supply do not turn off the electrical current that is supplied to the device. The device also might have more than one power cord. To remove all electrical current from the device, ensure that all power cords are disconnected from the power source.

Before installing the system board:

1. Touch the static-protective package that contains the component to any unpainted metal surface on the server; then, remove it from the package and place it on a static-protective surface.
2. Install the processor to the system board (see “Install the processor ” on page 113).
3. Install the heat sink and the fan module to the system board (see “Install the heat sink and the fan module” on page 93).

To install the system board, complete the following steps:

- Step 1. Align the serial port with the corresponding opening on the rear of the chassis; then, gently lower the system board into the chassis.

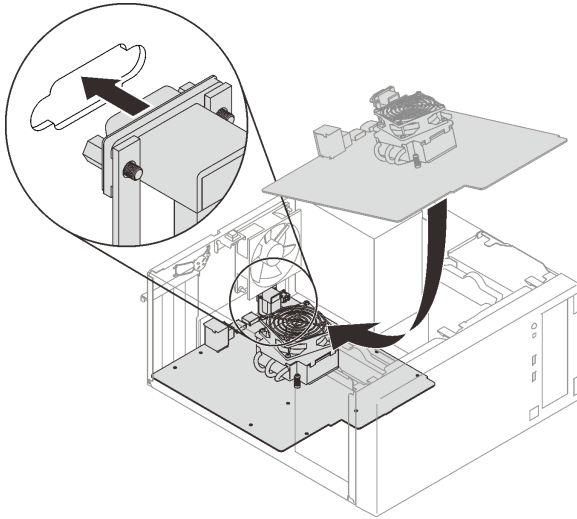

Figure 111. Installing the system board

- Step 2. Secure the system board to the chassis with eight screws in the following order.

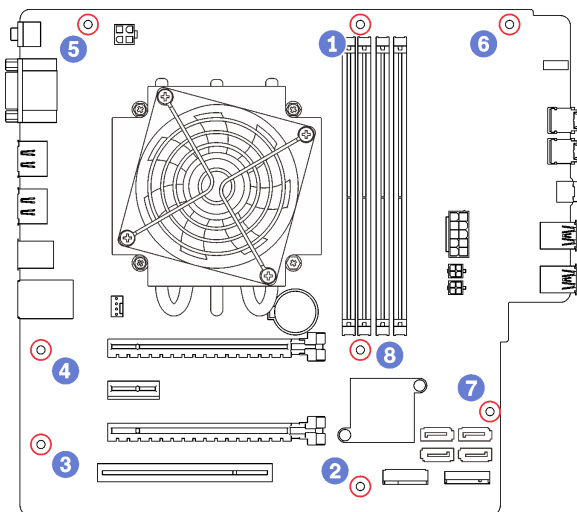

Figure 112. System board screw installation sequence

After installing the system board:

1. Install the CMOS battery if necessary (see “Install the CMOS battery” on page 35).
2. Install the DIMMs (see “Install a DIMM” on page 40).
3. Install the PCIe adapters (see “Remove a PCIe adapter” on page 99).
4. Reconnect all the cables that were disconnected.
5. Complete the parts replacement. See “Complete the parts replacement” on page 125.

Thermal sensor replacement

Follow this procedure to remove and install the thermal sensor.

Remove the thermal sensor

Follow this procedure to remove the thermal sensor.

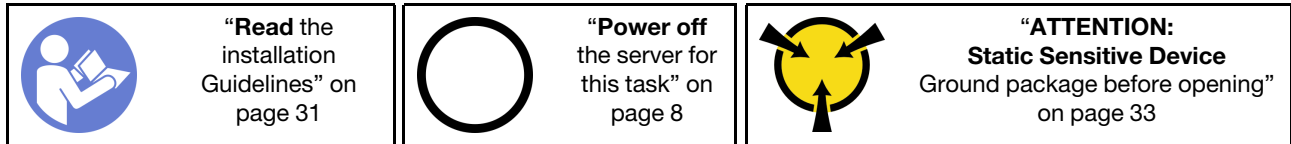

S002

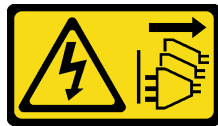

CAUTION:

The power control button on the device and the power switch on the power supply do not turn off the electrical current that is supplied to the device. The device also might have more than one power cord. To remove all electrical current from the device, ensure that all power cords are disconnected from the power source.

Before removing the thermal sensor:

1. Read the safety information and installation guidelines (see “Safety” on page iii and “Installation guidelines” on page 31).
2. Turn off the server and peripheral devices, and disconnect the power cords and all external cables (see “Power off the server” on page 8).
3. If the server is in a rack, remove it from the rack.
4. Remove any locking device that secures the server cover, such as a Kensington lock or a pad lock.
5. Remove the server cover (see “Remove the server cover” on page 115).

CAUTION:

The heat sinks and processor could be very hot. To avoid from burning yourself, wait for a few minutes after turning off the server before you remove the server cover.

6. Remove the front bezel (see “Remove the front bezel” on page 83).

To remove the thermal sensor, complete the following steps:

- Step 1. Disconnect the thermal sensor cable from the system board.

Step 2. Press the retaining clip on the top of the thermal sensor, and pull to remove the sensor from the chassis.

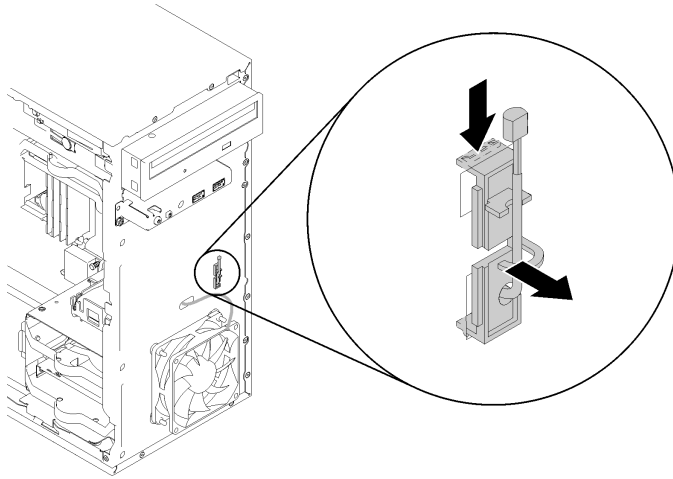



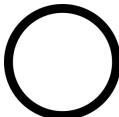

Figure 113. Removing the thermal sensor

After removing the thermal sensor:

1. Install another thermal sensor (see “Install the thermal sensor” on page 124).
2. If you are instructed to return the defective component, package the part to prevent any shipping damage. Reuse the packaging of the new part that arrived, and follow all available packaging instructions.

Install the thermal sensor

Follow this procedure to install the thermal sensor.

 <p>“Read the installation Guidelines” on page 31</p>	 <p>“Power off the server for this task” on page 8</p>	 <p>“ATTENTION: Static Sensitive Device Ground package before opening” on page 33</p>
--	---	---

S002



CAUTION:

The power control button on the device and the power switch on the power supply do not turn off the electrical current that is supplied to the device. The device also might have more than one power cord. To remove all electrical current from the device, ensure that all power cords are disconnected from the power source.

Before installing the thermal sensor:

1. Touch the static-protective package that contains the component to any unpainted metal surface on the server; then, remove it from the package and place it on a static-protective surface.

To install a thermal sensor, complete the following steps:

Step 1. Route the thermal sensor cable through the hole on the front of the chassis as illustrated.

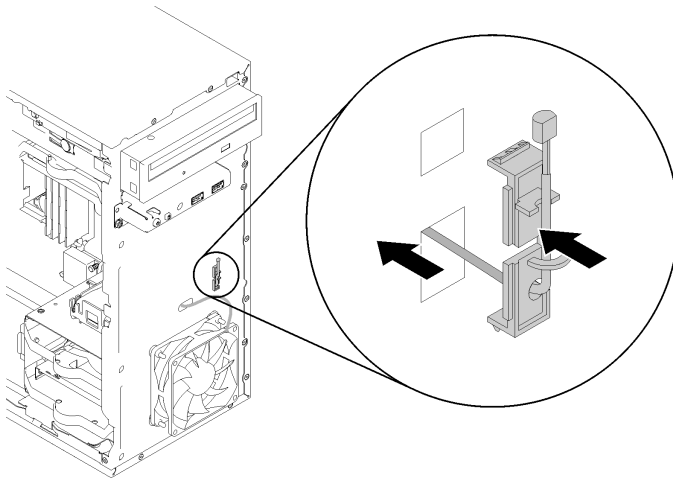

Figure 114. Installing the thermal sensor

Step 2. Align the sensor to the corresponding holes on the front of the chassis, and push the sensor towards the chassis until it clicks into place.

Step 3. Connect the thermal sensor cable to the system board. To locate the connector on the system board, see “System board components” on page 13.

After installing the thermal sensor:

1. Install the front bezel (see “Install the front bezel” on page 85).
2. Proceed to complete the parts replacement (see “Complete the parts replacement” on page 125).

Complete the parts replacement

Follow this procedure to complete the parts replacement.

To complete the parts replacement, do the following:

1. Ensure that all the removed components have been reinstalled correctly and that no tools or loose screws are left inside the server.
2. Properly route and secure the cables in the server. Refer to the cable connecting and routing information for each component.
3. If the server cover has been removed, reinstall it. See “Install the server cover” on page 117.
4. If the server was removed from the rack previously, put it back into the rack.
5. Reconnect external cables and power cords to the server.

Attention: To avoid component damage, connect all the other cables before connecting the power cords .

6. Update the server configuration if necessary.
 - Download and install the latest device drivers: <http://datacentersupport.lenovo.com>
 - Update the system firmware..

Chapter 4. Problem determination

Use the information in this section to isolate and resolve issues that you might encounter while using your server.

Event logs

Logs of system events are available in Setup Utility.

Setup Utility provides the list of system event log that is available in the security tab. Start the server and press **F1** to access Setup Utility, and go to **Security → System Event Log → View System Event Log** to access the list of events.

Following is the list of events that might appear in the system event log.

Table 28. List of log events in Setup Utility

Event description
Setup data integrity check failure
Memory size decreased
Fan failure
Power supply overload
BIOS password changed
BIOS Setup data changed
Chassis intrusion
Password retry count exceeded
SATA device configuration changed
BIOS updated
Option ROM over Shadow RAM size
Hard disk password changed
PCI Mem Conflict
System event log cleared

General problem determination procedures

Use the information in this section to resolve problems if the event log does not contain specific errors or the server is inoperative.

If you are not sure about the cause of a problem and the power supplies are working correctly, complete the following steps to try to resolve the problem:

1. Check in Setup Utility and make sure all the installed components are enabled.
2. Make sure the firmware of the installed components are the latest version.
3. Turn off the server.
4. Ensure that the server is cabled correctly.

5. Remove or disconnect the following devices, one at a time, until you find the failure. Turn on and configure the server each time you remove or disconnect a device.
 - Any external devices
 - Surge-suppressor device (on the server)
 - Printer, mouse, and non-Lenovo devices
 - Each adapter
 - Storage drives
 - One memory module at a time until you reach the minimum configuration that is supported for the server

Note: The minimum configuration required for the server to start is one processor and one 4 GB DIMM.

6. Turn on the server.
7. Listen to the POST error beeps.

Table 29. POST error beeps

Beep	Error description
Two short ones	There is one or more POST error.
Three short one followed by one long one	No memory is detected by the system.
Two long one followed by three short ones	No video adapter is detected by the system.
Four long ones	<ul style="list-style-type: none"> • Error “8998 - No enough shadow RAM resources for option ROM” on page 130: insufficient RAM resources • Error “8999 - No enough PCIe/PCI MMIO resources” on page 130: insufficient PCIe/PCI MMIO resources

Note: A short beep lasts about 0.5 second, while a long one lasts about one second.

If the problem is solved after an adapter is removed from the server, but recurs after it is reinstalled, suspect the adapter. If the problem recurs when the adapter is replaced with a different one, try the original adapter in a different PCIe slot.

If the problem appears to be a networking one while the server passes all system diagnostics, suspect a network cabling problem that is external to the server.

List of POST error messages

See this section for the list of POST error and related information.

00CE - Machine Type or Serial Number is INVALID

Machine type or serial number invalid.

This error message will be displayed if one of the following conditions is true:

1. Machine type and model name is invalid.
2. System serial number is invalid.

0135 - Fan Failure

Fan related failures.

This error message will be displayed if one of the following malfunctions occurs:

1. Heat sink fan failure
2. Front fan failure
3. Rear fan failure

4. Optical disk drive fan failure

0211 - Keyboard Not Found

No keyboard is found.

This error message will be displayed when no keyboard (PS/2 or USB) is detected.

0164 - Memory Size Decreased

Memory size is decreased.

When **Configuration Change Detection** is enabled, this error message will be displayed when the memory size is decreased.

To clear this error from the list of POST events, go do Setup Utility and select **Save Changes and Exit**.

1762 - SATA Device Configuration Change Has Occurred

SATA device configuration has been changed.

When **Configuration Change Detection** is enabled, this error message will be displayed when there is any configuration change related to SATA drives, including optical drives.

Notes:

1. Change the drive SATA connectors will cause this error.
2. To clear this error from the list of POST events, go do Setup Utility and select **Save Changes and Exit**.

1962 - No Operating System Found

No Operating System Found. Boot sequence will automatically repeat.

This error is not a general POST error, since it occurs after the POST finished. If there are no other bootable devices in the current boot sequence, this error message will be displayed and followed by an automatic boot sequence after one second.

0162 - Setup data integrity check failure

This error message indicates the checksum of BIOS Setup data in NVRAM is bad.

To clear this error from the list of POST events, go do Setup Utility and select **Save Changes and Exit**.

0167 - No Processor Microcode Update Found

This error message indicates that there is no microcode update image exists for the current processor.

0175 - System Security - Security data corrupted

This error message indicates the stored security data is corrupted.

To clear this error from the list of POST events, go do Setup Utility and select **Save Changes and Exit**.

0176 - System Security - The system has been tampered with

The system has been tampered with.

When **Chassis Intrusion Function** is enabled, this error will be displayed when the cover is not properly installed before the server is powered on.

To clear this error from the list of POST events, go do Setup Utility and select **Save Changes and Exit**.

0189 - System Security - Cannot read the Security EEPROM

The Security EEPROM cannot be accessed.

During POST, a read/write test is performed to verify access to the Security EEPROM. This error message indicates that the Security EEPROM may be corrupted or removed.

To clear this error from the list of POST events, go do Setup Utility and select **Save Changes and Exit**.

0197 - System Security - Unauthorized security data change detected

There is unauthorized security data change.

During POST, the hash of current security data is computed and compared with the one kept in security EEPROM. If they are not the same, this error will be displayed.

To clear this error from the list of POST events, go do Setup Utility and select **Save Changes and Exit**.

0190 - System Security - Invalid security change requested

An invalid request of security change is received.

During POST, CRC of the data stored in security EEPROM block 7 is computed and compared with the one kept in the block 7. If they do not match, this error will be displayed.

To clear this error from the list of POST events, go do Setup Utility and select **Save Changes and Exit**.

0199 - System Security - Security password retry count exceeded on last boot

Wrong passwords are inputted for more than the number of times that is allowed.

When **Security Password Count Exceeded Error** is enabled, this error will be displayed after wrong passwords are inputted over maximal number of times. Select **F2 to resume** and input the correct password.

To clear this error from the list of POST events, go do Setup Utility and select **Save Changes and Exit**.

8997 - System firmware has detected the system configuration may exceed the power supply capacity

The required amount of power of the present system configuration is more than the power supply could afford.

This error will be displayed when the system algorithm determines that present power consumption exceeds the capacity of the installed power supply unit. This error message is supposed to be displayed for at least five seconds and follow by another boot.

8998 - No enough shadow RAM resources for option ROM

Not enough shadow RAM resources for option ROM. Not all devices are initialized. Please remove some add-on cards or change to UEFI mode in BIOS Setup Utility.

This error message indicates some devices are not properly initiated. Remove them or change the settings in Setup Utility. It will be displayed for at least five seconds before the next boot.

8999 - No enough PCIe/PCI MMIO resources

Not enough PCIe/PCI MMIO resources. Currently only one video card is enabled. Please remove some PCIe cards, or enter BIOS Setup Utility and enable "Above 4GB Decode" if using a 64-bit OS.

This error will be displayed when there is not enough PCIe/PCI MMIO resources following a reboot and with the attempt to initialize the primary video device to display this error message. This error will be displayed for at least five seconds before the next boot. Remove some PCIe adapters in Setup Utility to solve this error.

Resolving suspected power problems

Power problems can be difficult to solve. For example, a short circuit can exist anywhere on any of the power distribution buses. Usually, a short circuit will cause the power subsystem to shut down because of an overcurrent condition.

Complete the following steps to diagnose and resolve a suspected power problem.

- Step 1. Check for short circuits, for example, if a loose screw causes short circuit on a circuit board.
- Step 2. Remove the adapters and disconnect the cables and power cords to all internal and external devices until the server is at the minimum configuration that is required for the server to start. See “Specifications” on page 4 to determine the minimum configuration for the server.
- Step 3. Reconnect all AC power cords and turn on the server. If the server starts successfully, reseal the adapters and devices one at a time until the problem is isolated.

If the server does not start from the minimum configuration, replace the components in the minimum configuration one at a time until the problem is isolated.

Resolving suspected Ethernet controller problems

The method that you use to test the Ethernet controller depends on which operating system you are using. See the operating-system documentation for information about Ethernet controllers, and see the Ethernet controller device-driver readme file.

Complete the following steps to try to resolve suspected problems with the Ethernet controller.

- Step 1. Make sure that the correct device drivers which come with the server are installed, and that they are at the latest level.
- Step 2. Make sure that the Ethernet cable is installed correctly.
 - The cable must be securely attached at all connections. If the cable is attached but the problem remains, try a different cable.
 - If you set the Ethernet controller to operate at 100 Mbps or 1000 Mbps, you must use Category 5 cabling.
- Step 3. Determine whether the hub supports auto-negotiation. If it does not, try configuring the integrated Ethernet controller manually to match the speed and duplex mode of the hub.
- Step 4. Check the Ethernet controller LEDs on the rear panel of the server. These LEDs indicate whether there is a problem with the connector, cable, or hub.
 - The Ethernet link status LED is lit when the Ethernet controller receives a link pulse from the hub. If the LED is off, there might be a defective connector or cable or a problem with the hub.
 - The Ethernet transmit/receive activity LED is lit when the Ethernet controller sends or receives data over the Ethernet network. If the Ethernet transmit/receive activity is off, make sure that the hub and network are operating and that the correct device drivers are installed.
- Step 5. Check for operating-system-specific causes of the problem, and also make sure that the operating system drivers are installed correctly.
- Step 6. Make sure that the device drivers on the client and server are using the same protocol.

If the Ethernet controller still cannot connect to the network, but the hardware appears to be working, the network administrator must investigate other possible causes of the error.

Troubleshooting by symptom

Follow this procedure to find solutions to problems that have identifiable symptoms.

To use the symptom-based troubleshooting information in this section, complete the following steps:

1. Review this section to find the symptoms that you are experiencing, and follow the suggested actions to resolve the issue.
2. If the problem persists, contact support (see “Contacting Support” on page 144).

Power on and power off problems

Follow this procedure to resolve issues when powering on or powering off the server.

- “Embedded hypervisor is not in the boot list” on page 132
- “The server does not power on” on page 132
- “Server powers off unexpectedly” on page 133
- “Server does not power off” on page 133
- “Message “ME BIOS SYNC - Get Redirection Features State Error” is displayed in the booting screen with Intel Celeron series (G49xx) processors” on page 133

Embedded hypervisor is not in the boot list

Complete the following steps until the problem is solved.

1. If the server has been installed, moved, or serviced recently, or if this is the first time the embedded hypervisor is being used, make sure that the device is connected properly and that there is no physical damage to the connectors.
2. See the documentation that comes with the optional embedded hypervisor device for setup and configuration information.
3. Make sure that software that is installed in the device works on another server to ensure that the device works properly.
4. Check <http://www.lenovo.com/us/en/serverproven/> to validate that the embedded hypervisor device is supported by the server.
5. Make sure that the embedded hypervisor device is included in the list of available boot options. To view the list of boot sequences, go to **Setup Utility**, select **Startup → Primary Boot Sequence**.
6. Check <http://datacentersupport.lenovo.com> for any tech tips (service bulletins) related to the embedded hypervisor and the server.

The server does not power on

Complete the following steps until the problem is solved.

Note: The power button will not function until approximately one to three minutes after the server is connected to ac power.

1. Remove any optional devices that were installed recently. System power problems caused by addition of a device indicates this device is either incompatible or too much for the power supply to support.
2. Make sure the power cord is securely connected to the server and to a working electrical outlet. Disconnect and reconnect or replace the server power cord.
3. Remove and reinstall the power supply. If the problem persists, replace the power supply.

4. Disconnect and reconnect the front panel cable (see “System board components” on page 13 for the location of the connector on the system board). If the problem persists, replace the front panel.

Server powers off unexpectedly

Complete the following steps until the problem is solved.

1. Make sure the room temperature does not cause overheating, and no object is blocking the airflow in front and back of the server.
2. Remove any optional devices that were installed recently. System power problems caused by addition of a device indicates this device is either incompatible or too much for the power supply to support.
3. Make sure the power cord is securely connected to the server and to a working electrical outlet. Disconnect and reconnect or replace the server power cord.
4. Reseat the power supply. If the problem persists, replace the power supply.

Server does not power off

Complete the following steps until the problem is solved.

1. Determine whether you are using an Advanced Configuration and Power Interface (ACPI) or a non-ACPI operating system. If you are using a non-ACPI operating system, complete the following steps:
 - a. Press Ctrl+Alt+Delete.
 - b. Turn off the server by pressing and holding the power button for five seconds.
 - c. Power on the server.
 - d. If the server fails POST and the power button does not work, disconnect the power cord for 20 seconds; then, reconnect the power cord and power on the server.
2. If the problem persists or if you are using an ACPI-aware operating system, suspect the system board.

Message “ME BIOS SYNC - Get Redirection Features State Error” is displayed in the booting screen with Intel Celeron series (G49xx) processors

1. Go to **Setup Utility**, select **Advance** → **Intel(R) Manageability** , and select **Disabled**.
2. Select **Save & Exit**. The error message will not be displayed again in the next booting screen.

Memory problems

Follow this procedure to resolve issues related to memory.

- “Displayed system memory less than installed physical memory” on page 133

Displayed system memory less than installed physical memory

Note: Each time you install or remove a DIMM, you must disconnect the server from the power source; then, wait 10 seconds before restarting the server.

Complete the following steps until the problem is solved.

1. Check the system event log and resolve any related problems. To view the system event log, go to **Setup Utility** and select **Security** → **System Event Log** → **View System Event Log**.
2. Make sure that:
 - The DIMMs are supported by the server (see <http://www.lenovo.com/us/en/serverproven/>).
 - The DIMMs are properly installed. Examine if there is any gap between the connector and the DIMM. Remove and install the DIMM if there is any.

3. If the server comes with Lenovo XClarity Provisioning Manager Lite, go to **Diagnostics → Memory test** to perform diagnostics on the DIMMs. Replace the DIMM that is displayed as faulty. Otherwise, skip to the next step.
4. Remove the DIMMs until the system reaches minimal memory requirement; then, add one DIMM and reboot the server, and repeat the step if the problem does not recur. If the problem occurs after addition of a DIMM, replace it.

Hard disk drive problems

Follow this procedure to resolve issues related to the hard disk drives.

- “Server cannot recognize a drive” on page 134
- “Multiple hard drives fail” on page 134
- “A replacement drive does not rebuild” on page 134
- “Suspected RAID volume failure” on page 135

Server cannot recognize a drive

Complete the following steps until the problem is solved.

1. Check the system event log and resolve any related problems. To view the system event log, go to **Setup Utility** and select **Security → System Event Log → View System Event Log**.
2. Make sure that:
 - The drive is supported by the server (see <http://www.lenovo.com/us/en/serverproven/>).
 - The drive is properly installed with signal and power cables properly connected.
3. Make sure the drive is enabled. Go to **Setup Utility** and select **Devices → ATA Drive Setup** to see if the drive in question is enabled. If not, enable it.
4. If the server comes with LXPM Lite, go to **Diagnostics → HDD test** to perform diagnostics on the drives. Replace the drive that is displayed as faulty. Otherwise, skip to the next step.
5. Remove the drives until the system reaches minimal drive requirement; then, add one drive and restart the server, and repeat the step if the problem does not recur. If the problem occurs after addition of a drive, replace it.

Multiple hard drives fail

Complete the following steps until the problem is solved.

1. Check the system event log and resolve any related problems. To view the system event log, go to **Setup Utility** and select **Security → System Event Log → View System Event Log**.
2. If the server comes with Lenovo XClarity Provisioning Manager Lite, go to **Diagnostics → HDD test** to perform diagnostics on the drives. Replace the drive that is displayed as faulty. Otherwise, skip to the next step.
3. Remove the drives until the system reaches minimal drive requirement; then, add one drive and reboot the server, and repeat the step if the problem does not recur. If the problem occurs after addition of a drive, replace it.

A replacement drive does not rebuild

Complete the following steps until the problem is solved.

1. Check the system event log and resolve any related problems. To view the system event log, go to **Setup Utility** and select **Security → System Event Log → View System Event Log**.

2. If the server comes with Lenovo XClarity Provisioning Manager Lite, go to **Diagnostics → RAID Log**. Look for related errors and solve them. Otherwise, skip to the next step.
3. Review the document that came with the RAID adapter to make sure RAID is set properly.

Suspected RAID volume failure

The following two symptoms serve as indicator of ThinkSystem RAID adapter virtual driver failure:

- If the virtual driver application is installed in a bootable Operating System drive, the system, unable to boot, stays in POST screen with message of Error 1962: No Operating system found. Boot sequence will automatically resume.
- Otherwise, the drive is missing from disk management options in the operating system.

Complete the following steps until the problem is solved.

1. Reboot the system, press **F1** to go to **Setup Utility**, and select **Devices**. See if the option of **AVAGO MRAID <RAID xxx-xx> Configuration Utility - xx.xx.xx.xx** exists in this tab.
2. If the option is missing, select **Driver Health → AVAGO EFI SAS Driver Failed → RAID xxx-xx Configuration Required → Enter Your Input Here**, and type **C** then **Y**. After that, **AVAGO MRAID Configuration Utility - xx.xx.xx.xx** should appear in **Devices** tab. If it is
3. If it is possible to replace the faulty drive immediately:
 - a. Go to **AVAGO MRAID <RAID xxx-xx> Configuration Utility - xx.xx.xx.xx → Main Menu → Drive Management** to identify the faulty drive.
 - b. Power off the system, and replace the drive (see “Drive replacement” on page 42).
 - c. Power on the system. The virtual driver will start rebuilding immediately.

If it requires Lenovo support to possible to replace:

- a. Go to **AVAGO MRAID <RAID xxx-xx> Configuration Utility - xx.xx.xx.xx → Controller Management → Advanced Controller Properties → Boot Mode → Ignore errors**, and select **Apply Changes**.
- b. Reboot the system. The virtual driver will be able to continue working.
- c. Call Lenovo support to replace the drive.

Monitor and video problems

Follow this procedure to solve problems related to a monitor or video.

- “Incorrect characters are displayed” on page 135
- “Screen is blank” on page 135
- “Screen goes blank when you start some application programs” on page 136
- “The monitor has screen jitter, or the screen image is wavy, unreadable, rolling, or distorted.” on page 136

Incorrect characters are displayed

Complete the following steps until the problem is solved.

1. Verify that the language and locality settings are correct for the keyboard and operating system.
2. If the wrong language is displayed, update the server firmware to the latest level.

Screen is blank

Complete the following steps until the problem is solved.

1. If you have installed new DIMMs recently, make sure the capacity of the new DIMMs are the same as the previously installed ones. If not, remove the newly installed DIMMs, and power on the server again.
2. If a graphical adapter is installed, wait for a while as it takes about three minutes before Lenovo logo is displayed.
3. If there are other monitors that are connected to the server, remove them.
4. Make sure that:
 - The server is turned on.
 - The monitor cables are securely connected.
 - The monitor is turned on with brightness and contrast controls adjusted correctly.
5. Disconnect the cable and select another video connector for connection.
6. Replace the following components one at a time, in the order shown, restarting the server each time:
 - a. Monitor cable
 - b. Monitor
 - c. Video adapter (if one is installed)
 - d. (Trained technician only) System board

Screen goes blank when you start some application programs

Complete the following steps until the problem is solved.

1. Make sure that:
 - The application program is not set in a display mode with resolution that is higher than the capability of the monitor (1152 x 864).
 - The necessary device drivers for the application are all installed.

The monitor has screen jitter, or the screen image is wavy, unreadable, rolling, or distorted.

Complete the following steps until the problem is solved.

1. If the monitor self-tests show that the monitor is working correctly, examine the location of the monitor. Magnetic fields around other devices (such as transformers, appliances, fluorescent, and other monitors) can cause screen jitter or wavy, unreadable, rolling, or distorted screen images. If this happens, turn off the monitor.

Attention: Moving a color monitor while it is turned on might cause screen discoloration.

Move the device and the monitor at least 305 mm (12 inches) apart, and turn on the monitor.

Notes:

- a. To prevent diskette drive read/write errors, make sure that the distance between the monitor and any external diskette drive is at least 76 mm (3 inches).
 - b. Non-Lenovo monitor cables might cause unpredictable problems.
2. Disconnect and reconnect the monitor cable.
 3. Replace the following components one at a time, in the order shown, restarting the server each time:
 - a. Monitor cable
 - b. Monitor
 - c. Video adapter (if one is installed)
 - d. (Trained technician only) System board

Keyboard, mouse, or USB-device problems

Follow this procedure to solve problems related to a keyboard, mouse, or USB device.

- “Keyboard or mouse does not work” on page 137
- “USB-device does not work” on page 137
- “Unable to use the configuration USB Key (setup.bin) to configure Intel AMT” on page 137

Keyboard or mouse does not work

Complete the following steps until the problem is solved.

1. Make sure that:
 - The keyboard/mouse cable is securely connected.
 - The server and the monitor are both turned on.
 - The latest version of corresponding driver is installed.
 - USB keyboard/mouse function is enabled. Go to **Setup Utility**, and select **Devices → USB Setup → USB Legacy Support** to examine the status. If it is disabled, enable it.
2. If the keyboard/mouse is connected to a USB hub, remove the keyboard from the hub, and connect it directly to the server.
3. Disconnect the keyboard/mouse and connect it to another USB connector.
4. If the problem recurs, replace the keyboard/mouse.

USB-device does not work

Complete the following steps until the problem is solved.

1. Make sure that:
 - The device is supported by the server (see <http://www.lenovo.com/us/en/serverproven/>).
 - The corresponding USB device driver is installed.
 - The operating system supports USB devices.
 - The USB port adopted is enabled. Go to **Setup Utility**, and select **Devices → USB Setup** to examine the status. If it is disabled, enable it. Make sure **USB Support** is enabled, too.
2. If the device is connected to a USB hub, remove the device from the hub, and connect it directly to the server.
3. Disconnect the keyboard and connect it to another USB connector.
4. If the problem recurs, replace the device.

Unable to use the configuration USB Key (setup.bin) to configure Intel AMT

Complete the following steps until the problem is solved.

1. Reboot the system.
2. Go to **Setup Utility**, and select **Advanced → Intel ® Manageability → USB Provisioning**, and enable it.
3. Press **F10** to save the setting.

Optional-device problems

Follow this procedure to solve problems related to optional devices.

- “PCIe adapter is not recognized or is not functioning” on page 137
- “A Lenovo optional device that worked previously does not work now. ” on page 138
- “A Lenovo optional device that was just installed does not work.” on page 138
- “A Lenovo optional device that worked previously does not work now. ” on page 138

PCIe adapter is not recognized or is not functioning

Complete the following steps until the problem is solved.

1. Check the system event log and resolve any related problems. To view the system event log, go to **Setup Utility** and select **Security → System Event Log → View System Event Log**.
2. Make sure that:
 - The device is supported by the server (see <http://www.lenovo.com/us/en/serverproven/>).
 - The latest version of corresponding driver is installed.
 - The device is seated correctly without physical damage on the device or connector.
 - System firmware has been updated to the latest version.
3. Remove the device and install it to another PCIe slot if possible.
4. Check <http://datacentersupport.lenovo.com> for any tech tips (also known as retain tips or service bulletins) that might be related to the adapter.

Insufficient PCIe resources are detected.

Complete the following steps until the problem is solved.

1. Remove any devices that were installed recently, and restart the server. If none was recently installed, remove one of the PCIe adapters.
2. Go to **Setup Utility** and select **Devices → PCI Express Configuration**; then, modify the setting to a lower speed. For example, modify Auto or Gen3 to Gen2 or Gen1.
3. Save the settings and restart the server.
4. Depending on whether or not the restart is successful:
 - If it is successful, shut down the server and reinstall the removed PCIe adapters one at a time, and restart the server again after each addition.
 - If it fails, remove another PCIe adapter and restart the server again.

A Lenovo optional device that was just installed does not work.

Complete the following steps until the problem is solved.

1. Check the system event log and resolve any related problems. To view the system event log, go to **Setup Utility** and select **Security → System Event Log → View System Event Log**.
2. Make sure that:
 - The device is supported by the server (see <http://www.lenovo.com/us/en/serverproven/>).
 - The latest version of corresponding driver is installed.
 - The device is seated correctly without physical damage on the device or connector.
 - System firmware has been updated to the latest version.
 - You followed the installation instructions that came with the device, and the device is installed properly.
 - You have not loosened any other installed devices or cables.
3. Reseat the device.
4. Replace the device.

A Lenovo optional device that worked previously does not work now.

Complete the following steps until the problem is solved.

1. Check the system event log and resolve any related problems. To view the system event log, go to **Setup Utility** and select **Security → System Event Log → View System Event Log**.
2. Make sure that all of the cables are securely connected.
3. If the device comes with test instructions, use those instructions to test the device.
4. Reseat the failing device.
5. Replace the failing device.

Intermittent problems

Follow this procedure to solve intermittent problems.

- “Intermittent external device problems” on page 139
- “Intermittent unexpected reboots” on page 139

Intermittent external device problems

Complete the following steps until the problem is solved.

1. Check the system event log and resolve any related problems. To view the system event log, go to **Setup Utility** and select **Security → System Event Log → View System Event Log**.
2. Make sure that:
 - The latest version of corresponding driver is installed.
 - The device is seated correctly without physical damage on the device or connector.
 - System firmware has been updated to the latest version.
 - You followed the installation instructions that came with the device, and the device is installed properly.
 - You have not loosened any other installed devices or cables.
3. For a USB device:
 - a. Make sure that the device is properly configured and enabled in Setup Utility.
 - b. Connect the device to another USB port.
 - c. If the device is connected to a USB hub, remove the device from the hub, and connect it directly to the server.

Intermittent unexpected reboots

Complete the following steps until the problem is solved.

1. Check the system event log and resolve any issues related to this device. To view the system event log, go to **Setup Utility** and select **Security → System Event Log → View System Event Log**.
2. If the reboot occurs after the operating system starts, disable any automatic server restart (ASR) utilities, such as the Automatic Server Restart IPMI Application for Windows, or any ASR devices that are installed.
3. Look into the event logs for an event code that indicates a reboot. See “Event logs” on page 127 for information about viewing the event log.

Network problems

Follow this procedure to resolve issues related to networking.

- “Cannot wake server using Wake on LAN” on page 139
- “Could not log in using LDAP account with SSL enabled” on page 140

Cannot wake server using Wake on LAN

Complete the following steps until the problem is solved.

1. Check the system event log and resolve any related problems. To view the system event log, go to **Setup Utility** and select **Security → System Event Log → View System Event Log**.
2. Change the Wake on LAN setting. Go to **Setup Utility** and select **Power → Automatic Power On → Wake on LAN**. The default setting is automatic. Change it to primary.
3. Remove and reinstall the network adapter.

4. Turn off the server and disconnect it from the power source; then, wait 10 seconds before restarting the server.
5. If the problem recurs, replace the network adapter.

Could not log in using LDAP account with SSL enabled

Complete the following steps until the problem is solved.

1. Make sure that the license key is valid.
2. Generate a new license key and log in again.

Observable problems

Follow this procedure to solve observable problems.

- “The server immediately displays the POST Event Viewer when it is turned on” on page 140
- “Server is unresponsive (POST is complete and operating system is running)” on page 140
- “Server is unresponsive (cannot press F1 to start Setup Utility)” on page 141
- “Voltage planar fault is displayed in the event log” on page 141
- “Unusual smell” on page 141
- “Server seems to be running hot” on page 141
- “Cracked parts or cracked chassis” on page 141

The server immediately displays the POST Event Viewer when it is turned on

Complete the following steps until the problem is solved.

1. Make sure that the server supports the processor.
To view processor details, go to **Setup Utility** and select **Main → System Summary**.
To determine if the processor is supported for the server, see <http://www.lenovo.com/us/en/serverproven/>.
2. (Trained technician only) Make sure that the processor is installed properly.
3. Replace the following components one at a time, in the order shown, and restart the server after each replacement.
 - a. (Trained technician only) processor
 - b. (Trained technician only) system board

Server is unresponsive (POST is complete and operating system is running)

Complete the following steps until the problem is solved.

- If you have direct access to the server, complete the following steps:
 1. If possible, log in to the system and verify that all applications are running without hanging.
 2. Restart the server.
 3. If the problem recurs, make sure that every newly installed software is configured correctly.
 4. Contact the vendor or provider of the software for technical support.
- If you have remote access to the server, complete the following steps:
 1. If possible, log in to the system and verify that all applications are running without hanging.
 2. Log out of the system and log back in.

3. Validate the network access by pinging or running traceroute to the server with a command line.
 - a. If you are unable to get a response during a ping test, try to ping another server in the same server room to determine whether the problem is caused by failed connection of the server.
 - b. Run traceroute to determine where the connection breaks down, and try to resolve the connection issue with VPN or avoiding where the connection breaks down.
4. Restart the server remotely.
5. If the problem recurs, make sure that every installed software is configured correctly.
6. Contact the vendor or provider of the software for technical support.

Server is unresponsive (cannot press F1 to start Setup Utility)

Complete the following steps until the problem is solved.

Note: Any configuration changes, such as system firmware update, device and corresponding driver installation, could cause failed POST.

If this occurs, the server responds in either of the following ways:

- The system restarts automatically and produces POST again.
- The server hangs, and you must manually reboot the system so that the system produces POST again.

Voltage planar fault is displayed in the event log

Complete the following steps until the problem is solved.

1. Revert the system to the minimum configuration. See “Specifications” on page 4 for details.
2. Restart the server.
 - If the system does restart successfully, add the devices that are removed one at a time, and restart the server after each addition until the problem occurs. Replace the device that causes the problem.
 - If the system fails to restart, there might be a problem with the system board. Call Lenovo support.

Unusual smell

Complete the following steps until the problem is solved.

1. Any unusual smell might come from newly installed devices. Examine the devices to identify the source of the smell, and remove the one that produces it.
2. If the problem recurs, contact Lenovo Support.

Server seems to be running hot

Complete the following steps until the problem is solved.

1. Make sure that the room temperature is within the specified range (see “Specifications” on page 4).
2. Adjust the ICE Performance Mode (ICE) setting. Go to **Setup Utility** and select **Power → Intelligent Cooling Engine (ICE) → ICE Performance Mode**. If the server is set in **Better Acoustic Performance**, select **Better Thermal Performance** and press **Enter**.
3. Check the system event log and resolve any related problems. To view the system event log, go to **Setup Utility** and select **Security → System Event Log → View System Event Log**.
4. If there are no related events in the log, contact Lenovo Support.

Cracked parts or cracked chassis

Contact Lenovo Support.

Software problems

Follow this procedure to solve software problems.

1. To determine whether the problem is caused by the software, make sure that:
 - The server has the minimum memory that is needed to use the software. For memory requirements, see the information that comes with the software.

Note: If you have just installed an adapter or memory, the server might have a memory-address conflict.
 - The software is designed to operate on the server.
 - Other software works on the server.
 - The software works on another server.
2. If you receive any error messages while you use the software, see the information that comes with the software for a description of the messages and suggested solutions to the problem.
3. Contact your place of purchase of the software.

Appendix A. Getting help and technical assistance

If you need help, service, or technical assistance or just want more information about Lenovo products, you will find a wide variety of sources available from Lenovo to assist you.

On the World Wide Web, up-to-date information about Lenovo systems, optional devices, services, and support are available at:

<http://datacentersupport.lenovo.com>

Note: This section includes references to IBM web sites and information about obtaining service. IBM is Lenovo's preferred service provider for ThinkSystem.

Before you call

Before you call, there are several steps that you can take to try and solve the problem yourself. If you decide that you do need to call for assistance, gather the information that will be needed by the service technician to more quickly resolve your problem.

Attempt to resolve the problem yourself

You can solve many problems without outside assistance by following the troubleshooting procedures that Lenovo provides in the online help or in the Lenovo product documentation. The Lenovo product documentation also describes the diagnostic tests that you can perform. The documentation for most systems, operating systems, and programs contains troubleshooting procedures and explanations of error messages and error codes. If you suspect a software problem, see the documentation for the operating system or program.

You can find the product documentation for your ThinkSystem products at the following location:

<http://thinksystem.lenovofiles.com/help/index.jsp>

You can take these steps to try to solve the problem yourself:

- Check all cables to make sure that they are connected.
- Check the power switches to make sure that the system and any optional devices are turned on.
- Check for updated software, firmware, and operating-system device drivers for your Lenovo product. The Lenovo Warranty terms and conditions state that you, the owner of the Lenovo product, are responsible for maintaining and updating all software and firmware for the product (unless it is covered by an additional maintenance contract). Your service technician will request that you upgrade your software and firmware if the problem has a documented solution within a software upgrade.
- If you have installed new hardware or software in your environment, check <http://www.lenovo.com/us/en/serverproven/> to make sure that the hardware and software is supported by your product.
- Go to <http://datacentersupport.lenovo.com> and check for information to help you solve the problem.
 - Check the Lenovo forums at https://forums.lenovo.com/t5/Datacenter-Systems/ct-p/sv_eg to see if someone else has encountered a similar problem.

You can solve many problems without outside assistance by following the troubleshooting procedures that Lenovo provides in the online help or in the Lenovo product documentation. The Lenovo product documentation also describes the diagnostic tests that you can perform. The documentation for most systems, operating systems, and programs contains troubleshooting procedures and explanations of error

messages and error codes. If you suspect a software problem, see the documentation for the operating system or program.

Gathering information needed to call Support

If you believe that you require warranty service for your Lenovo product, the service technicians will be able to assist you more efficiently if you prepare before you call. You can also see <http://datacentersupport.lenovo.com/warrantylookup> for more information about your product warranty.

Gather the following information to provide to the service technician. This data will help the service technician quickly provide a solution to your problem and ensure that you receive the level of service for which you might have contracted.

- Hardware and Software Maintenance agreement contract numbers, if applicable
- Machine type number (Lenovo 4-digit machine identifier)
- Model number
- Serial number
- Current system UEFI and firmware levels
- Other pertinent information such as error messages and logs

As an alternative to calling Lenovo Support, you can go to <https://www-947.ibm.com/support/servicerequest/Home.action> to submit an Electronic Service Request. Submitting an Electronic Service Request will start the process of determining a solution to your problem by making the pertinent information available to the service technicians. The Lenovo service technicians can start working on your solution as soon as you have completed and submitted an Electronic Service Request.

Contacting Support

You can contact Support to obtain help for your issue.

You can receive hardware service through a Lenovo Authorized Service Provider. To locate a service provider authorized by Lenovo to provide warranty service, go to <https://datacentersupport.lenovo.com/serviceprovider> and use filter searching for different countries. For Lenovo support telephone numbers, see <https://datacentersupport.lenovo.com/supportphonenumber>. In the U.S. and Canada, call 1-800-426-7378.

In the U.S. and Canada, hardware service and support is available 24 hours a day, 7 days a week. In the U.K., these services are available Monday through Friday, from 9 a.m. to 6 p.m.

China product support

To contact product support in China, go to: <http://support.lenovo.com.cn/lenovo/wsi/es/ThinkSystem.html>

You can also call 400-106-8888 for product support. The call support is available Monday through Friday, from 9 a.m. to 6 p.m.

Taiwan product support

To contact product support for Taiwan, call 0800-016-888. The call support is available 24 hours a day, 7 days a week.

Appendix B. Notices

Lenovo may not offer the products, services, or features discussed in this document in all countries. Consult your local Lenovo representative for information on the products and services currently available in your area.

Any reference to a Lenovo product, program, or service is not intended to state or imply that only that Lenovo product, program, or service may be used. Any functionally equivalent product, program, or service that does not infringe any Lenovo intellectual property right may be used instead. However, it is the user's responsibility to evaluate and verify the operation of any other product, program, or service.

Lenovo may have patents or pending patent applications covering subject matter described in this document. The furnishing of this document is not an offer and does not provide a license under any patents or patent applications. You can send inquiries in writing to the following:

*Lenovo (United States), Inc.
1009 Think Place
Morrisville, NC 27560
U.S.A.
Attention: Lenovo VP of Intellectual Property*

LENOVO PROVIDES THIS PUBLICATION "AS IS" WITHOUT WARRANTY OF ANY KIND, EITHER EXPRESS OR IMPLIED, INCLUDING, BUT NOT LIMITED TO, THE IMPLIED WARRANTIES OF NON-INFRINGEMENT, MERCHANTABILITY OR FITNESS FOR A PARTICULAR PURPOSE. Some jurisdictions do not allow disclaimer of express or implied warranties in certain transactions, therefore, this statement may not apply to you.

This information could include technical inaccuracies or typographical errors. Changes are periodically made to the information herein; these changes will be incorporated in new editions of the publication. Lenovo may make improvements and/or changes in the product(s) and/or the program(s) described in this publication at any time without notice.

The products described in this document are not intended for use in implantation or other life support applications where malfunction may result in injury or death to persons. The information contained in this document does not affect or change Lenovo product specifications or warranties. Nothing in this document shall operate as an express or implied license or indemnity under the intellectual property rights of Lenovo or third parties. All information contained in this document was obtained in specific environments and is presented as an illustration. The result obtained in other operating environments may vary.

Lenovo may use or distribute any of the information you supply in any way it believes appropriate without incurring any obligation to you.

Any references in this publication to non-Lenovo Web sites are provided for convenience only and do not in any manner serve as an endorsement of those Web sites. The materials at those Web sites are not part of the materials for this Lenovo product, and use of those Web sites is at your own risk.

Any performance data contained herein was determined in a controlled environment. Therefore, the result obtained in other operating environments may vary significantly. Some measurements may have been made on development-level systems and there is no guarantee that these measurements will be the same on generally available systems. Furthermore, some measurements may have been estimated through extrapolation. Actual results may vary. Users of this document should verify the applicable data for their specific environment.

Trademarks

LENOVO and THINKSYSTEM are trademarks of Lenovo. All other trademarks are the property of their respective owners.

Intel and Xeon are trademarks of Intel Corporation in the United States, other countries, or both.

Microsoft and Windows are trademarks of the Microsoft group of companies.

Linux is a registered trademark of Linus Torvalds.

Other company, product, or service names may be trademarks or service marks of others.

Important notes

Processor speed indicates the internal clock speed of the microprocessor; other factors also affect application performance.

CD or DVD drive speed is the variable read rate. Actual speeds vary and are often less than the possible maximum.

When referring to processor storage, real and virtual storage, or channel volume, KB stands for 1 024 bytes, MB stands for 1 048 576 bytes, and GB stands for 1 073 741 824 bytes.

When referring to hard disk drive capacity or communications volume, MB stands for 1 000 000 bytes, and GB stands for 1 000 000 000 bytes. Total user-accessible capacity can vary depending on operating environments.

Maximum internal hard disk drive capacities assume the replacement of any standard hard disk drives and population of all hard-disk-drive bays with the largest currently supported drives that are available from Lenovo.

Maximum memory might require replacement of the standard memory with an optional memory module.

Each solid-state memory cell has an intrinsic, finite number of write cycles that the cell can incur. Therefore, a solid-state device has a maximum number of write cycles that it can be subjected to, expressed as total bytes written (TBW). A device that has exceeded this limit might fail to respond to system-generated commands or might be incapable of being written to. Lenovo is not responsible for replacement of a device that has exceeded its maximum guaranteed number of program/erase cycles, as documented in the Official Published Specifications for the device.

Lenovo makes no representations or warranties with respect to non-Lenovo products. Support (if any) for the non-Lenovo products is provided by the third party, not Lenovo.

Some software might differ from its retail version (if available) and might not include user manuals or all program functionality.

Particulate contamination

Attention: Airborne particulates (including metal flakes or particles) and reactive gases acting alone or in combination with other environmental factors such as humidity or temperature might pose a risk to the device that is described in this document.

Risks that are posed by the presence of excessive particulate levels or concentrations of harmful gases include damage that might cause the device to malfunction or cease functioning altogether. This specification sets forth limits for particulates and gases that are intended to avoid such damage. The limits must not be viewed or used as definitive limits, because numerous other factors, such as temperature or moisture content of the air, can influence the impact of particulates or environmental corrosives and gaseous contaminant transfer. In the absence of specific limits that are set forth in this document, you must implement practices that maintain particulate and gas levels that are consistent with the protection of human health and safety. If Lenovo determines that the levels of particulates or gases in your environment have caused damage to the device, Lenovo may condition provision of repair or replacement of devices or parts on implementation of appropriate remedial measures to mitigate such environmental contamination. Implementation of such remedial measures is a customer responsibility.

Table 30. Limits for particulates and gases

Contaminant	Limits
Particulate	<ul style="list-style-type: none"> The room air must be continuously filtered with 40% atmospheric dust spot efficiency (MERV 9) according to ASHRAE Standard 52.2¹. Air that enters a data center must be filtered to 99.97% efficiency or greater, using high-efficiency particulate air (HEPA) filters that meet MIL-STD-282. The deliquescent relative humidity of the particulate contamination must be more than 60%². The room must be free of conductive contamination such as zinc whiskers.
Gaseous	<ul style="list-style-type: none"> Copper: Class G1 as per ANSI/ISA 71.04-1985³ Silver: Corrosion rate of less than 300 Å in 30 days
<p>¹ ASHRAE 52.2-2008 - <i>Method of Testing General Ventilation Air-Cleaning Devices for Removal Efficiency by Particle Size</i>. Atlanta: American Society of Heating, Refrigerating and Air-Conditioning Engineers, Inc.</p> <p>² The deliquescent relative humidity of particulate contamination is the relative humidity at which the dust absorbs enough water to become wet and promote ionic conduction.</p> <p>³ ANSI/ISA-71.04-1985. <i>Environmental conditions for process measurement and control systems: Airborne contaminants</i>. Instrument Society of America, Research Triangle Park, North Carolina, U.S.A.</p>	

Telecommunication regulatory statement

This product may not be certified in your country for connection by any means whatsoever to interfaces of public telecommunications networks. Further certification may be required by law prior to making any such connection. Contact a Lenovo representative or reseller for any questions.

Electronic emission notices

When you attach a monitor to the equipment, you must use the designated monitor cable and any interference suppression devices that are supplied with the monitor.

Additional electronic emissions notices are available at:

<http://thinksystem.lenovofiles.com/help/index.jsp>

Taiwan BSMI RoHS declaration

單元 Unit	限用物質及其化學符號 Restricted substances and its chemical symbols					
	鉛Lead (Pb)	汞Mercury (Hg)	鎘Cadmium (Cd)	六價鉻 Hexavalent chromium (Cr ⁶⁺)	多溴聯苯 Polybrominated biphenyls (PBB)	多溴二苯醚 Polybrominated diphenyl ethers (PBDE)
機架	○	○	○	○	○	○
外部蓋板	○	○	○	○	○	○
機械組零件	-	○	○	○	○	○
空氣傳動設備	-	○	○	○	○	○
冷卻組零件	-	○	○	○	○	○
內存模塊	-	○	○	○	○	○
處理器模塊	-	○	○	○	○	○
電纜組零件	-	○	○	○	○	○
電源	-	○	○	○	○	○
儲備設備	-	○	○	○	○	○
電路卡	-	○	○	○	○	○
光碟機	-	○	○	○	○	○
雷射器	-	○	○	○	○	○
<p>備考1. “超出0.1 wt %” 及 “超出0.01 wt %” 係指限用物質之百分比含量超出百分比含量基準值。 Note1 : “exceeding 0.1wt%” and “exceeding 0.01 wt%” indicate that the percentage content of the restricted substance exceeds the reference percentage value of presence condition.</p> <p>備考2. “○” 係指該項限用物質之百分比含量未超出百分比含量基準值。 Note2 : “○” indicates that the percentage content of the restricted substance does not exceed the percentage of reference value of presence.</p> <p>備考3. “-” 係指該項限用物質為排除項目。 Note3 : The “-” indicates that the restricted substance corresponds to the exemption.</p>						

Taiwan import and export contact information

Contacts are available for Taiwan import and export information.

委製商/進口商名稱: 台灣聯想環球科技股份有限公司

進口商地址: 台北市南港區三重路 66 號 8 樓

進口商電話: 0800-000-702

Index

C

- cable routing
 - fan 24
 - front panel 24
 - hard-disk drive 16, 24
 - optical drive 18
 - power supply unit 23
 - RAID 20
 - simple-swap drive 16
 - slim odd 18
 - solid-state drive 16, 24
 - tape drive 18
 - thermal sensor 25
- CMOS battery
 - install 35
 - remove 33
 - replacing 33
- completing
 - parts replacement 125
- contamination, particulate and gaseous 146
- CR2032 33
- creating a personalized support web page 143
- custom support web page 143

D

- devices, static-sensitive
 - handling 33
- DIMM
 - installing 40
 - removing 37
 - replacing 37
- DIMM installation rules 38
- drive
 - replacing 42
- drive activity LED 9
- dual SD card adapter
 - installing 68
 - replacing 65
- dual SD card adapter module 14

E

- Ethernet
 - controller
 - troubleshooting 131
- Ethernet controller problems
 - solving 131
- expansion drive cage
 - removing 65

F

- fan
 - installing 72, 76
 - removing 71, 74
 - replacing 71
- fixed power supply
 - removing 105
- flash power module
 - installing 80
 - replacing 77
- form factor 3
- front bezel

- installing 85
- removing 83
- replacing 83

- front fan
 - installing 72
 - removing 71
- front panel 9
 - installing 88
 - removing 87
 - replacing 86
- front view 9
- front view of the server 9

G

- gaseous contamination 146
- Getting help 143
- guidelines
 - options installation 31
 - system reliability 32

H

- handling static-sensitive devices 33
- hard disk drive problems 134
- hardware service and support telephone numbers 144
- heat sink
 - installing 93
 - removing 90
- help 143

I

- ID label 1
- important notices 146
- install
 - CMOS battery 35
 - processor 113
- installation
 - guidelines 31
- installation guidelines 31
- installing
 - DIMM 40
 - dual SD card adapter 68
 - fan 72, 76
 - flash power module 80
 - front bezel 85
 - front fan 72
 - front panel 88
 - heat sink 93
 - intrusion switch 97
 - optical drive 55
 - power supply unit 108
 - processor fan 93
 - RDX/LTO 55
 - rear fan 76
 - server cover 117
 - simple-swap drive 47
 - slim optical drive 62
 - super capacity module 80
 - system board 121
 - tape drive 55
- insufficient PCIe resource
 - solving 137

- intermittent problems 139
- internal cable routing 15
- introduction 1
- intrusion switch
 - installing 97
 - removing 96
 - replacing 96

J

- jumper 14

K

- keyboard problems 136

M

- memory
 - problems 133
- monitor problems 135
- mouse problems 136

N

- network
 - problems 139
- network access label 1
- notes, important 146
- notices 145

O

- observable problems 140
- optical disk 42
- optical drive
 - installing 55
 - removing 52, 58
 - replacing 51
- optional-device problems 137

P

- particulate contamination 146
- parts list 26
- parts replacement, completing 125
- PCIe
 - troubleshooting 137
- PCIe adapter
 - replacing 99
- power button 9
- power cords 29
- power LED 9
- power off the server 8
- power on the server 8
- power problems 131
- power supply unit
 - installing 108
- power supply unit, replacing 105
- problem determination 127
- problems
 - Ethernet controller 131
 - hard disk drive 134
 - intermittent 139
 - keyboard 136

- memory 133
- monitor 135
- mouse 136
- network 139
- observable 140
- optional devices 137
- PCIe 137
- power 131
- power on and power off 132
- software 142
- USB device 136
- video 135
- processor
 - install 113
 - removing 112
 - replacing 112
- processor fan
 - installing 93
 - removing 90

R

- rear fan
 - installing 76
 - removing 74
- rear view 10
- remove
 - CMOS battery 33
- removing
 - DIMM 37
 - expansion drive cage 65
 - fan 71, 74
 - front bezel 83
 - front fan 71
 - front panel 87
 - heat sink 90
 - intrusion switch 96
 - optical drive 52, 58
 - power supply unit 105
 - processor 112
 - processor fan 90
 - RDX/LTO 52
 - rear fan 74
 - server cover 115
 - simple-swap drive 43
 - system board 119
 - tape drive 52, 58
- replacing
 - CMOS battery 33
 - DIMM 37
 - drive 42
 - dual SD card adapter 65
 - fan 71, 90
 - flash power module 77
 - front bezel 83
 - front panel 86
 - heat sink 90
 - intrusion switch 96
 - optical drive 51
 - PCIe adapter 99
 - power supply unit, 105
 - processor 112
 - server cover 115
 - simple-swap drive 43
 - system board 119
 - tape drive 51
 - thermal sensor 123

S

- safety iii
- safety inspection checklist iv

- security advisories 7
- server components 9
- server cover
 - installing 117
 - removing 115
 - replacing 115
- server power on or power off problems 132
- server, front view 9
- service and support
 - before you call 143
 - hardware 144
 - software 144
- simple-swap drive 62
 - installing 47
 - replacing 43
- simple-swap drives
 - removing 43
- slim optical drive
 - installing 62
- software problems 142
- software service and support telephone numbers 144
- solving
 - Ethernet controller problems 131
 - insufficient PCIe resource 137
- solving power problems 131
- Specifications 4
- static-sensitive devices
 - handling 33
- support web page, custom 143
- system board
 - installing 121
 - removing 119
 - replacing 119
- system board components 13
- system reliability guidelines 32

T

- Taiwan BSMI RoHS declaration 148
- Taiwan import and export contact information 148

- tape drive 42
 - installing 55
 - removing 52, 58
 - replacing 51
- Tech Tips 7
- telecommunication regulatory statement 147
- telephone numbers 144
- thermal sensor
 - replacing 123
- trademarks 146
- troubleshooting 135, 137, 142
 - by symptom 132
 - hard disk drive problems 134
 - intermittent problems 139
 - keyboard problems 136
 - memory problems 133
 - mouse problems 136
 - network problems 139
 - observable problems 140
 - power on and power off problems 132
 - symptoms-based troubleshooting 132
 - USB-device problems 136
 - video 135

U

- update the firmware 7
- USB connector 9
- USB-device problems 136

V

- video problems 135

W

- warranty 1



Part Number: SP47A37799

Printed in China

(1P) P/N: SP47A37799

