

**ThinkCentre®**

M820z User Guide and Hardware  
Maintenance Manual

**Think**

**Lenovo**

**Energy Star Machine Types: 10SC, 10SD, 10Y7, and 10Y8**

**Note:** Before using this information and the product it supports, be sure to read and understand the *Important Product Information Guide* and Appendix A “Notices” on page 57.

**Third Edition (August 2019)**

**© Copyright Lenovo 2018, 2019.**

LIMITED AND RESTRICTED RIGHTS NOTICE: If data or software is delivered pursuant to a General Services Administration “GSA” contract, use, reproduction, or disclosure is subject to restrictions set forth in Contract No. GS-35F-05925.

---

# Contents

<b>Chapter 1. Overview . . . . .</b>	<b>1</b>
Front view . . . . .	1
Rear view . . . . .	3
System board . . . . .	4
Machine type and model label . . . . .	6
Adjusting the integrated camera module . . . . .	6
Adjusting the computer stand . . . . .	6
<b>Chapter 2. Specifications . . . . .</b>	<b>9</b>
<b>Chapter 3. Computer locks . . . . .</b>	<b>11</b>
<b>Chapter 4. Replacing hardware . . . . .</b>	<b>13</b>
Before replacing hardware . . . . .	13
Knowing FRUs (including CRUs) . . . . .	13
Locating FRUs (including CRUs) . . . . .	14
Replacing the computer stand . . . . .	16
Removing the computer cover . . . . .	18
Replacing the storage drive . . . . .	19
Replacing the optical drive . . . . .	21
Replacing the optical drive and storage drive cables . . . . .	24
Replacing the side I/O bezel . . . . .	25
Replacing the system board shield . . . . .	26

Replacing the VESA mount bracket . . . . .	27
Replacing the power supply assembly . . . . .	28
Replacing the cover presence switch . . . . .	30
Replacing the system fan . . . . .	31
Replacing the heat sink . . . . .	32
Replacing the microprocessor . . . . .	34
Replacing the Wi-Fi card . . . . .	38
Replacing the serial connector module . . . . .	39
Replacing the M.2 solid-state drive . . . . .	40
Replacing a memory module . . . . .	43
Replacing the coin-cell battery . . . . .	45
Replacing the card reader . . . . .	47
Replacing the system board . . . . .	48
Replacing the integrated camera module . . . . .	49
Replacing the internal speakers . . . . .	52
Replacing the Wi-Fi antennas . . . . .	53
Replacing the LCD panel . . . . .	55
Completing the parts replacement . . . . .	55

<b>Appendix A. Notices . . . . .</b>	<b>57</b>
--------------------------------------	-----------

<b>Appendix B. Trademarks . . . . .</b>	<b>59</b>
---	-----------



# Chapter 1. Overview

This chapter provides basic information to help you get familiar with your computer.

## Front view

**Note:** Your computer model might look slightly different from the illustration.

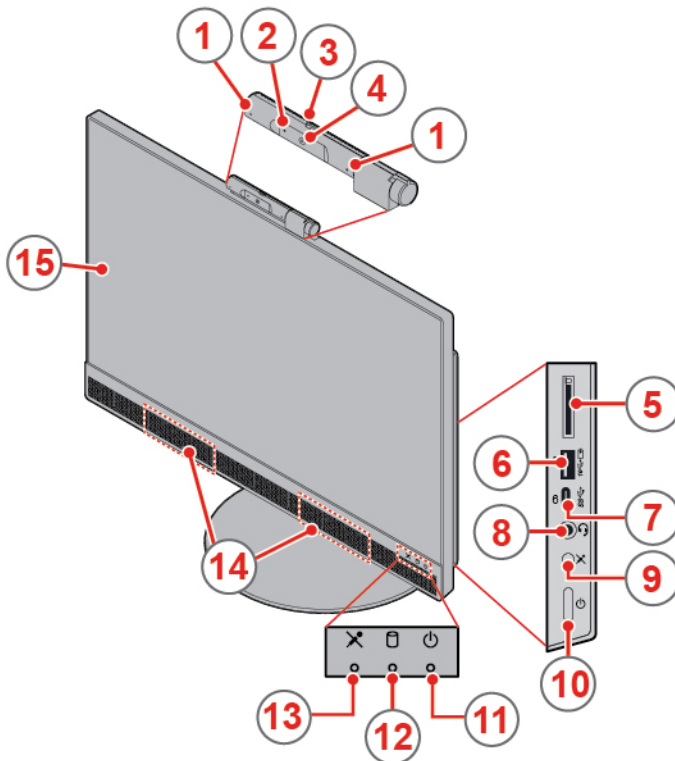

Figure 1. Front view

<b>1</b> Integrated microphones (2) (optional)	<b>2</b> Integrated camera activity indicator (optional)
<b>3</b> Integrated camera shield control slider (optional)	<b>4</b> Integrated camera (optional)
<b>5</b> Card reader slot (optional)	<b>6</b> Always On USB 3.1 Gen 2 connector (for rapid charge)
<b>7</b> USB-C™ connector	<b>8</b> Headset connector (also known as combo audio jack)
<b>9</b> Microphone mute/unmute control	<b>10</b> Power button
<b>11</b> Power indicator	<b>12</b> Storage drive activity indicator
<b>13</b> Microphone mute/unmute indicator	<b>14</b> Internal speakers (2)
<b>15</b> Screen	

### **1** Integrated microphones

Used to record sounds or use speech-recognition software without using a microphone.

**2 Integrated camera activity indicator**

When the indicator is on, the camera is in use.

**3 Integrated camera shield control slider**

Used to cover the camera lens.

**4 Integrated camera**

Used to take pictures or hold a video conference.

**5 Card reader slot**

Used to read data from a supported memory card.

**6 Always On USB 3.1 Gen 2 connector**

Used to connect a USB-compatible device. For optimal data transfer, connect a USB 3.1 Gen 2 device to a USB 3.1 Gen 2 connector instead of a USB 3.1 Gen 1 or USB 2.0 connector. With the ac power adapter connected, you can charge the automatically detected device even when the computer is in hibernation mode or turned off.

**7 USB-C connector**

Use the connector to transfer data (USB 3.1 Gen 1, 5.0Gbps) or charge your device (5V/3A).

**8 Headset connector**

Used to connect a headset or headphones to your computer.

**9 Microphone mute/unmute control**

Used to mute or unmute the integrated microphones in the computer mode.

**10 Power button**

Used to turn on your computer. When you cannot shut down the computer from the operating system, press and hold the power button for four or more seconds to turn off the computer.

**11 Power indicator**

This indicator is on when the computer is on.

**12 Storage drive activity indicator**

This indicator is on when the storage drive is in use.

**13 Microphone mute/unmute indicator**

This indicator is on when the microphones are muted.

**14 Internal speaker**

Used to listen to the sounds from your computer without using a headset or headphones.

## 15 Screen

Depending on the computer model, your computer screen might support the multi-touch feature. This feature enables you to use up to ten fingers to interact with the computer.

---

## Rear view

**Note:** Your computer model might look slightly different from the illustration.

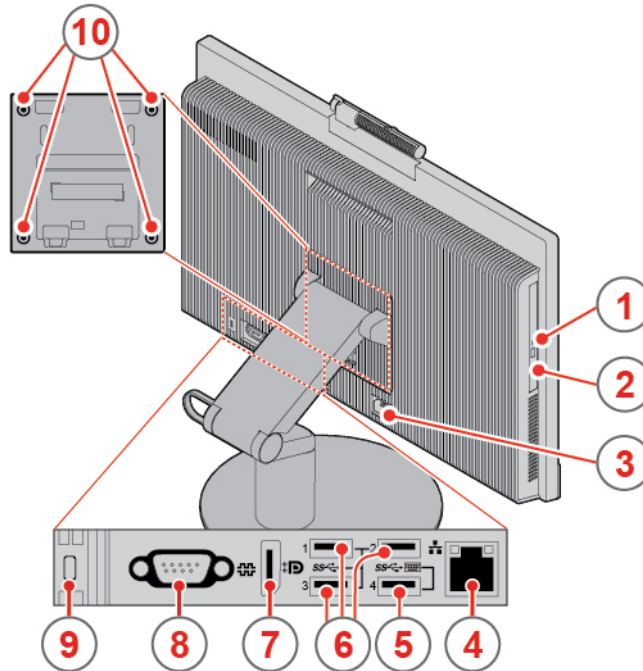

Figure 2. Rear view

<b>1</b> Optical drive activity indicator (optional)	<b>2</b> Optical drive eject/close button (optional)
<b>3</b> Power cord connector	<b>4</b> Ethernet connector
<b>5</b> USB 3.1 Gen 1 connector (supporting the smart power on feature)	<b>6</b> USB 3.1 Gen 1 connectors (3)
<b>7</b> DisplayPort® 1.2 out connector	<b>8</b> Serial connector (optional)
<b>9</b> Security-lock slot	<b>10</b> VESA threaded holes (screws: M4 x 8 mm x 4 pcs)

### **1** Optical drive activity indicator

This indicator is on when the optical drive is in use.

### **2** Optical drive eject/close button

Used to eject the tray of the optical drive. After you insert a disc into the tray, press the eject/close button to close the tray.

### **3** Power cord connector

Used to connect the power cord to your computer for power supply.

#### **4 Ethernet connector**

Used to connect an Ethernet cable for network access.

#### **5 USB 3.1 Gen 1 connector**

Used to connect a USB-compatible device. For optimal data transfer, connect a USB 3.1 Gen 1 device to a USB 3.1 Gen 2 or USB 3.1 Gen 1 connector instead of a USB 2.0 connector. The connector supports the smart power on feature that enables you to turn on the computer or wake it up from S4 hibernation mode by pressing Alt+P on the keyboard. You can enable or disable the smart power on feature from the Setup Utility program. For detailed information, see *Important Product Information Guide*.

#### **6 USB 3.1 Gen 1 connector**

Used to connect a USB-compatible device. For optimal data transfer, connect a USB 3.1 Gen 1 device to a USB 3.1 Gen 2 or USB 3.1 Gen 1 connector instead of a USB 2.0 connector.

#### **7 DisplayPort 1.2 out connector**

Used to send audio and video signals from the computer to another audio or video device, such as a high-performance monitor.

#### **8 Serial connector**

Used to connect an external modem, a serial printer, or other devices that use a serial connector.

#### **9 Security-lock slot**

Used to secure a Kensington-style cable lock.

#### **10 VESA threaded holes**

Used to connect the matched VESA mount with the matched screws when you install the computer on a wall.

---

## **System board**

**Note:** See “Front view” and “Rear view” for additional component descriptions.



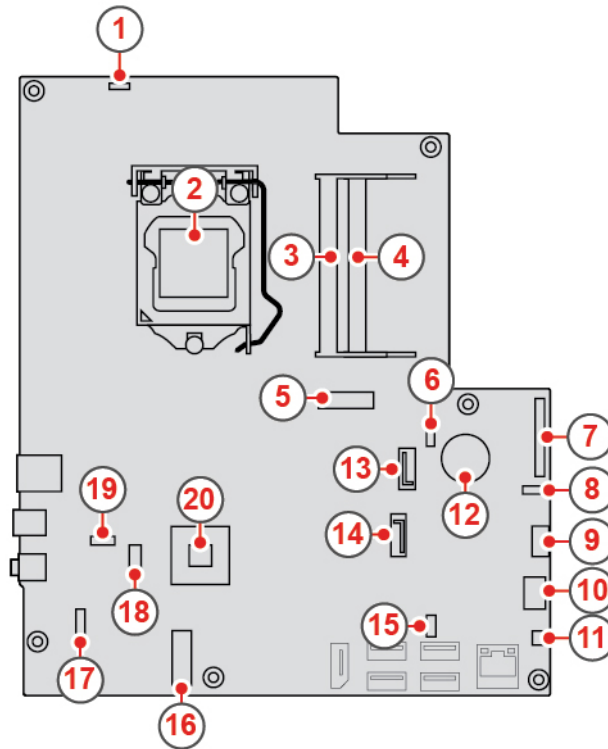

Figure 3. System board

<b>1</b> Integrated camera module connector	<b>2</b> Microprocessor socket
<b>3</b> Memory slot (DIMM1)	<b>4</b> Memory slot (DIMM2)
<b>5</b> M.2 solid-state drive slot	<b>6</b> System fan connector
<b>7</b> LCD LVDS connector	<b>8</b> Touch board connector
<b>9</b> SATA power connector (connecting to the storage drive and optical drive)	<b>10</b> Power supply assembly connector
<b>11</b> Cover presence switch connector (intrusion switch connector)	<b>12</b> Coin-cell battery
<b>13</b> SATA connector (connecting to the optical drive)	<b>14</b> SATA connector (connecting to the storage drive)
<b>15</b> Serial (COM1) connector	<b>16</b> M.2 Wi-Fi card slot
<b>17</b> LCD power connector	<b>18</b> Internal speaker connector
<b>19</b> Card reader connector	<b>20</b> PCH

---

## Machine type and model label

The machine type and model label identifies the computer. When you contact Lenovo for help, the machine type and model information helps support technicians to identify the computer and provide faster service. The machine type and model label is attached on the computer as shown.

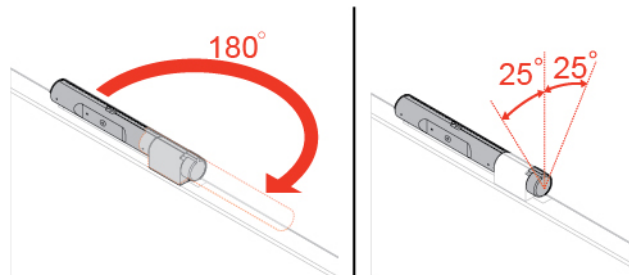

Figure 4. Machine type and model label

---

## Adjusting the integrated camera module

**Note:** The integrated camera module is optional.



---

## Adjusting the computer stand

**Note:** The computer stand is optional.

## Full-function monitor stand

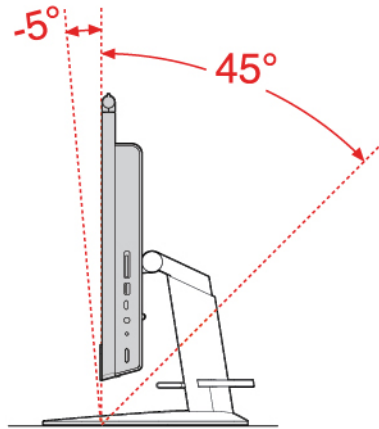

Figure 5. Tilting the screen forward and back

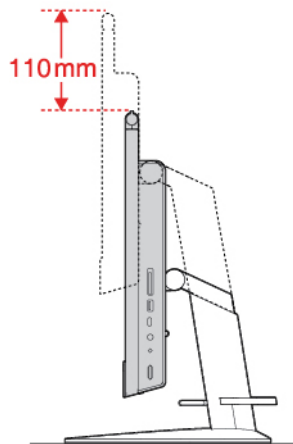

Figure 6. Adjusting the height of the screen

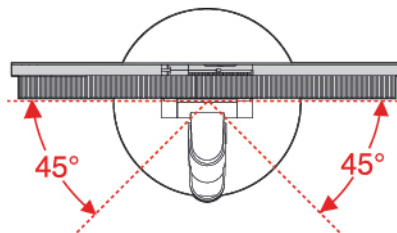

Figure 7. Turning the screen to the left and right

## UltraFlex III Stand

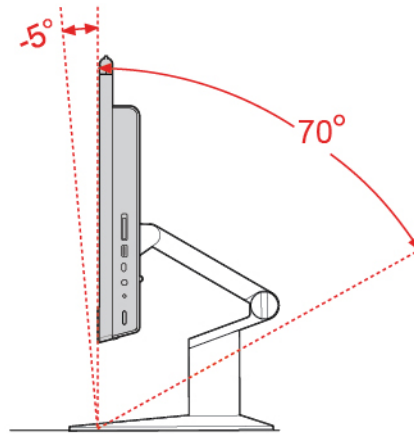

Figure 8. Tilting the screen forward and back

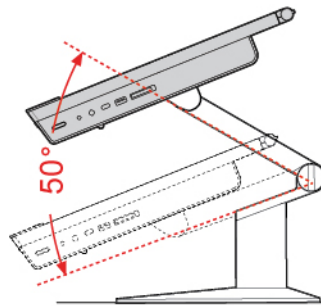

Figure 9. Pressing the screen downward after tilting it back

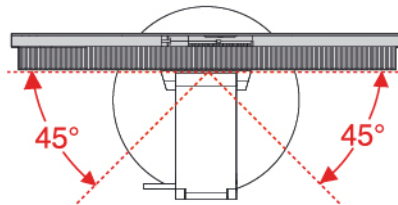

Figure 10. Turning the screen to the left and right

---

## Chapter 2. Specifications

### Power supply

150-watt automatic voltage-sensing power supply

### Storage drives

- 2.5-inch storage drive (optional)
- M.2 solid-state drive (optional)

### Video features

DisplayPort 1.2 out connector

### Audio features

- Headset connector
- Integrated microphones (optional)
- Internal speakers

### Input/Output (I/O) features

- Card reader slot (optional)
- DisplayPort 1.2 out connector
- Ethernet connector
- Headset connector
- Serial connector
- USB connectors

### Expansion

- Card reader
- Memory slots
- M.2 solid-state drive slot
- Optical drive (optional)
- Storage drive bay

### Network features

- Ethernet LAN
- Wireless LAN (optional)
- Bluetooth (optional)

### Physical dimensions (without the computer stand)

- Width: 491.1 mm (19.3 inches)
- Height: 342.4 mm (13.5 inches)
- Depth: 49.3 mm (1.9 inches)

### Weight (with the computer stand) (without the package)

Maximum configuration as shipped: 7.9 kg (21.7 lb)

### Statement on USB transfer rate

Depending on many factors such as the processing capability of the host and peripheral devices, file attributes, and other factors related to system configuration and operating environments, the actual transfer rate using the various USB connectors on this device will vary and will be slower than the data rate listed below for each corresponding device.

USB device	Data rate (Gbit/s)
3.1 Gen 1	5
3.1 Gen 2	10
3.2	20

---

## Chapter 3. Computer locks

### Attaching a Kensington-style cable lock

You can use a Kensington-style cable lock to secure your computer to a desk, table, or other nonpermanent fixture. The cable lock connects to the security-lock slot at the rear of your computer. Depending on the type selected, the cable lock can be operated with a key or combination. The cable lock also locks the buttons used to open the computer cover. This is the same type of lock used with many notebook computers. You can order such a cable lock directly from Lenovo by searching for *Kensington* at: <http://www.lenovo.com/support>

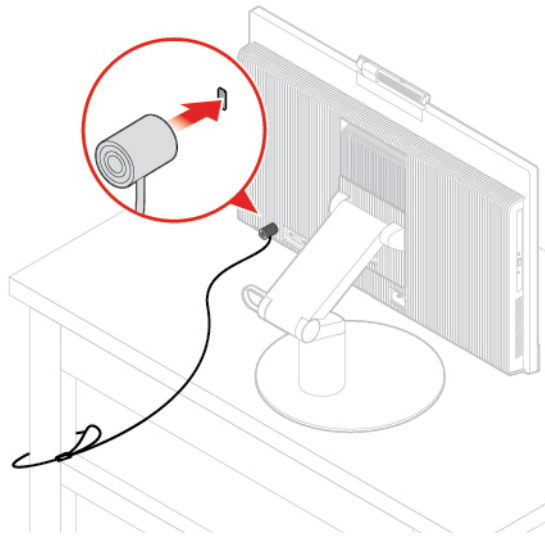

Figure 11. Attaching a Kensington-style cable lock





---

## Chapter 4. Replacing hardware

This chapter provides instructions on how to replace hardware for your computer.

---

### Before replacing hardware

**Attention:** Do not open your computer or attempt any repairs before reading this section and the *Important Product Information Guide*.

#### Notes before replacing hardware

- Use computer components provided only by Lenovo.
- When installing or replacing an option, use the appropriate instructions explained in this manual along with the instructions that come with the option.
- In most areas of the world, Lenovo requires the return of defective CRUs. Information about this will come with the CRU or will come a few days after the CRU arrives.

#### Handling static-sensitive devices

Do not open the static-protective package containing the new part until the defective part has been removed and you are ready to install the new part. Static electricity, although harmless to you, can seriously damage computer components and options.

When you handle options and other computer components, take these precautions to avoid static-electricity damage:

- Limit your movement. Movement can cause static electricity to build up around you.
- Always handle options and other computer components carefully. Handle PCI/PCIe cards, memory modules, system boards, and microprocessors by the edges. Never touch any exposed circuitry.
- Prevent others from touching the options and other computer components.
- Touch the static-protective package containing the part to a metal expansion-slot cover or other unpainted metal surface on the computer for at least two seconds. This reduces static electricity from the package and your body before you install or replace a new part.
- When possible, remove the new part from the static-protective package, and install it directly in the computer without setting the part down. When this is not possible, place the static-protective package on a smooth, level surface and place the part on the package.
- Do not place the part on the computer cover or other metal surface.

---

### Knowing FRUs (including CRUs)

- Field Replaceable Units (FRUs) are computer parts that a trained technician can upgrade or replace. FRUs include all CRUs. For detailed FRU information, such as the FRU part numbers and supported computer models, go to:  
<http://www.lenovo.com/serviceparts-lookup>
- Customer Replaceable Units (CRUs) are computer parts that a user can upgrade or replace.
  - Self-service CRUs: You can install self-service CRUs easily. These CRUs might be stand-alone, latched, or secured by up to two screws. Examples of self-service CRUs include the keyboard, mouse, any USB device. You are responsible for replacing all self-service CRUs.
  - Optional-service CRUs: Handling optional-service CRUs requires some technical skills and simple tools (such as a screwdriver). These CRUs are isolated parts within the computer. They are usually

concealed by an access panel that is secured by more than two screws. You must remove the screws and panel to access the specific CRU. Optional-service CRUs can be removed and installed by users or, during the warranty period, by a Lenovo service technician.

### **Before replacing FRUs**

Before replacing any FRU, read the following:

- Only certified and trained personnel can service the computer.
- Before replacing an FRU, read the entire section about replacing the part.
- Be extremely careful during writing operations such as copying, saving, or formatting.

The sequence of the drives in the computer that you are servicing might have been altered. If you select an incorrect drive, data or programs might be overwritten.

- Replace an FRU only with another FRU of the correct model.

When you replace an FRU, ensure that the model of the machine and the FRU part number are correct.

- An FRU should not be replaced because of a single, unreproducible failure.

Single failures can occur for a variety of reasons that have nothing to do with a hardware defect, such as cosmic radiation, electrostatic discharge, or software errors. Consider replacing an FRU only when a problem recurs. If you suspect that an FRU is defective, clear the error log and run the test again. If the error does not recur, do not replace the FRU.

- Only replace a defective FRU.

---

## **Locating FRUs (including CRUs)**

### **Notes:**

- Some of the following components are optional.
- To replace a component that is not in the list below, contact a Lenovo service technician. For a list of Lenovo Support phone numbers, go to:  
<http://www.lenovo.com/support/phone>

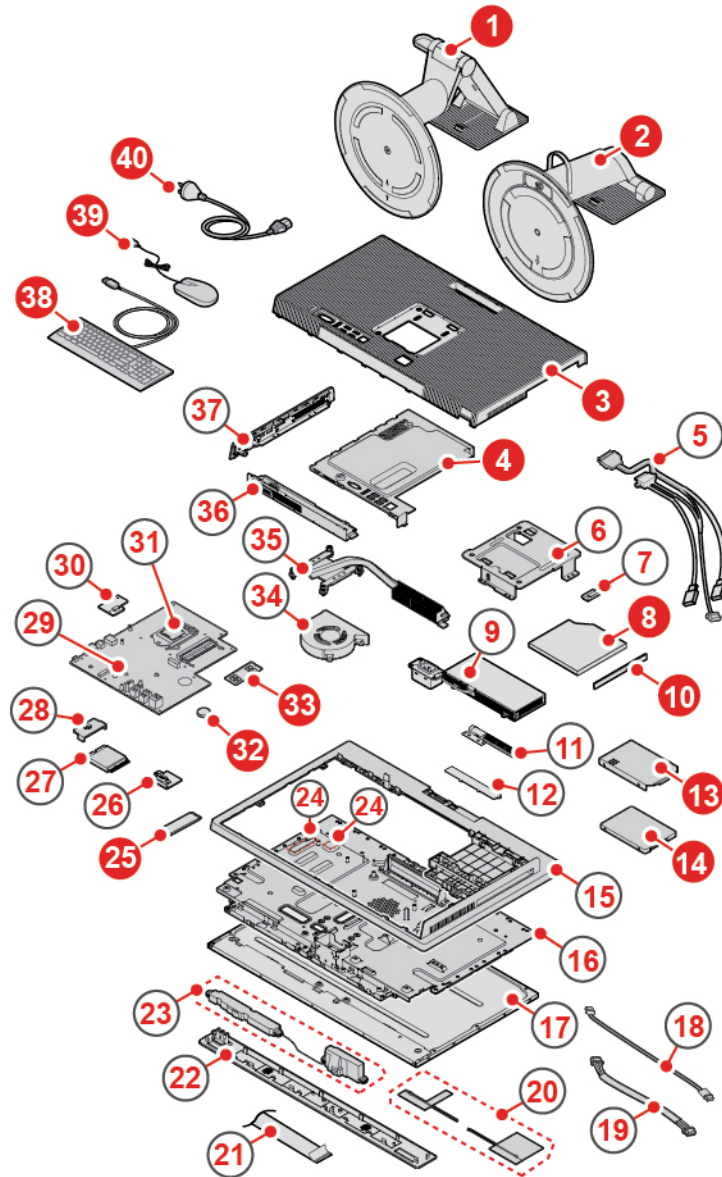

Figure 12. Locating FRUs (including CRUs)

Self-service CRUs	Optional-service CRUs	Non-CRUs
<b>1</b> UltraFlex III Stand	<b>4</b> System board shield	<b>5</b> Optical drive and storage drive cables
<b>2</b> Full-function monitor stand	<b>8</b> Optical drive	<b>6</b> VESA mount bracket
<b>3</b> Computer cover	<b>10</b> Optical drive bezel	<b>7</b> Optical drive holder
<b>13</b> Storage drive bracket	<b>25</b> M.2 solid-state drive	<b>9</b> Power supply assembly
<b>14</b> Storage drive	<b>32</b> Coin-cell battery	<b>11</b> Integrated camera and microphone module
<b>38</b> Keyboard	<b>33</b> Memory module	<b>12</b> Integrated camera and microphone module cover

Self-service CRUs	Optional-service CRUs	Non-CRUs
<p><b>39</b> Mouse</p> <p><b>40</b> Power cord</p>	<p><b>37</b> Side I/O bezel</p>	<p><b>15</b> Back frame</p> <p><b>16</b> Chassis</p> <p><b>17</b> LCD panel</p> <p><b>18</b> Backlight cable</p> <p><b>19</b> Touch cable</p> <p><b>20</b> Wi-Fi antennas (2)</p> <p><b>21</b> LVDS cable</p> <p><b>22</b> Front decorative cover</p> <p><b>23</b> Internal speakers (2)</p> <p><b>24</b> Thermal pads(2)</p> <p><b>26</b> Serial connector module</p> <p><b>27</b> Wi-Fi card shield</p> <p><b>28</b> Wi-Fi card</p> <p><b>29</b> System board</p> <p><b>30</b> Card reader</p> <p><b>31</b> Microprocessor</p> <p><b>34</b> System fan</p> <p><b>35</b> Heat sink</p> <p><b>36</b> System board shielding fence</p>

## Replacing the computer stand

**Attention:** Do not open your computer or attempt any repairs before reading the *Important Product Information Guide*.

1. Remove any media from the drives and turn off all connected devices and the computer.
2. Disconnect all power cords from electrical outlets and disconnect all cables from the computer.
3. Place a soft, clean towel or cloth on the desk or surface. Hold the sides of your computer and gently lay it down so that the screen is against the surface and the computer cover is facing up.
4. Depending on your computer model, refer to one of the following to replace the computer stand.
  - Full-function monitor stand

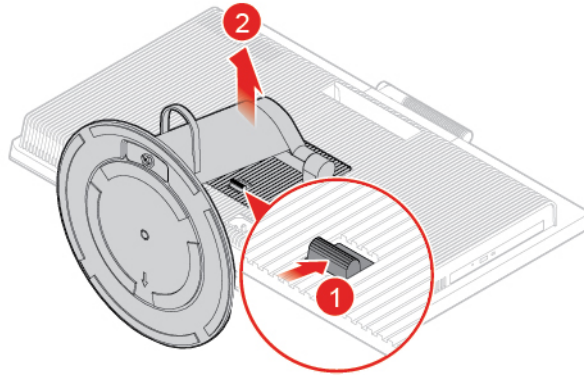

Figure 13. Removing the full-function monitor stand

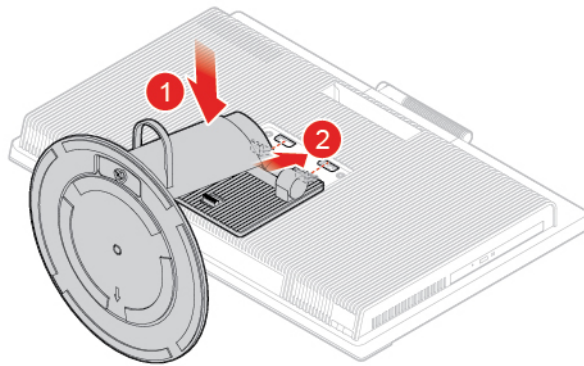

Figure 14. Installing the full-function monitor stand

- UltraFlex III Stand

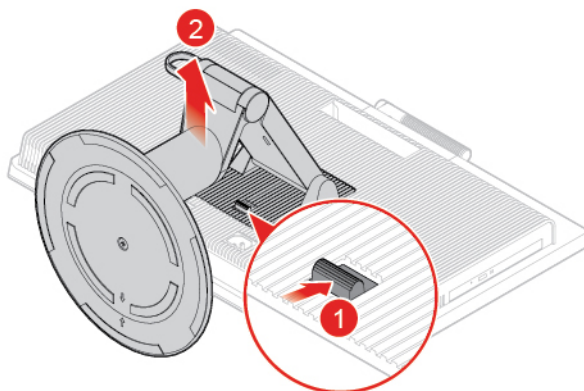

Figure 15. Removing the UltraFlex III Stand

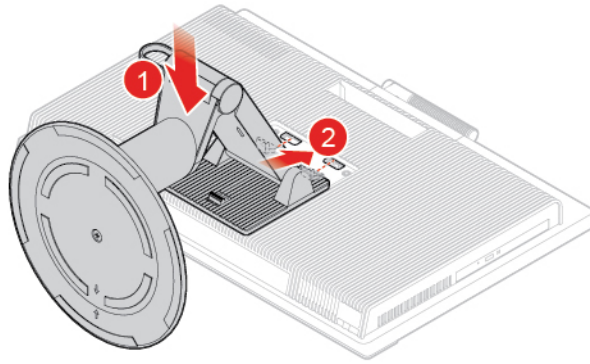

Figure 16. Installing the UltraFlex III Stand

5. Place the computer in an upright position.
6. Reconnect the external cables and power cords to the corresponding connectors on the computer.

---

## Removing the computer cover

**Attention:** Do not open your computer or attempt any repairs before reading the *Important Product Information Guide*.

**CAUTION:**



**Before you open the computer cover, turn off the computer and wait several minutes until the computer is cool.**

1. Remove any media from the drives and turn off all connected devices and the computer.
2. Disconnect all power cords from electrical outlets and disconnect all cables from the computer.
3. Unlock any locking device that secures the computer cover.
4. Place a soft, clean towel or cloth on the desk or surface. Hold the sides of your computer and gently lay it down so that the screen is against the surface and the computer cover is facing up.
5. Remove the computer stand. See “Replacing the computer stand” on page 16.

6. Remove the computer cover.

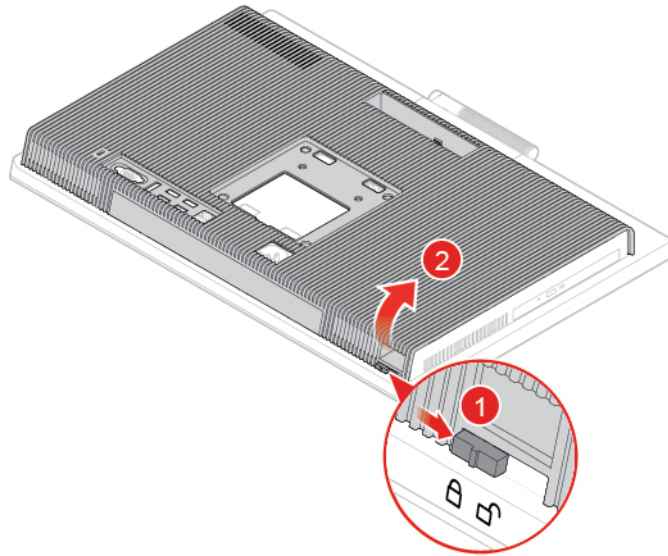

Figure 17. Removing the computer cover

7. Complete the replacement. See “Completing the parts replacement” on page 55.

---

## Replacing the storage drive

**Attention:** Do not open your computer or attempt any repairs before reading the *Important Product Information Guide*.

1. Remove the computer stand. See “Replacing the computer stand” on page 16.
2. Remove the computer cover. See “Removing the computer cover” on page 18.
3. Disconnect the signal cable and the power cable from the storage drive.
4. Replace the storage drive.

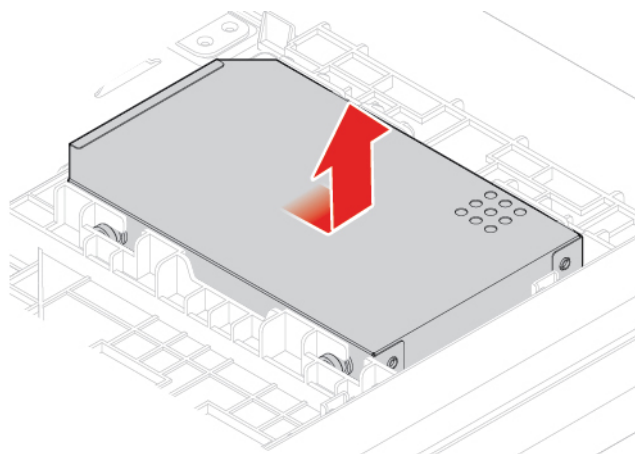

Figure 18. Removing the storage drive and the bracket

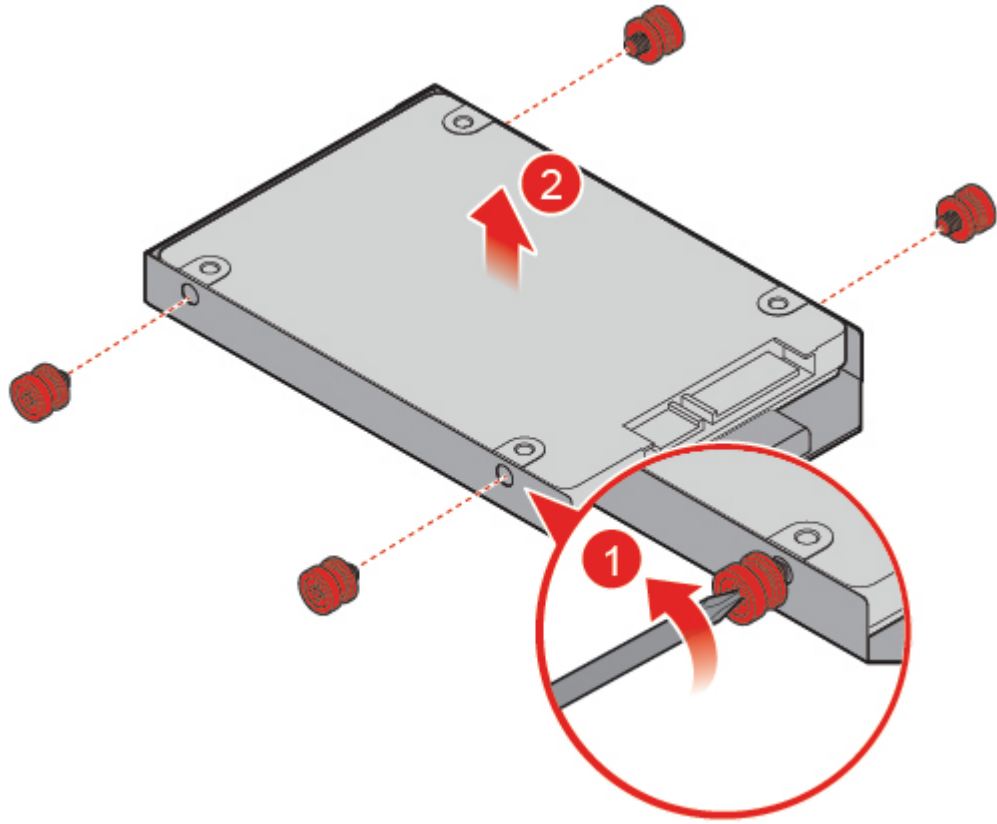

Figure 19. Removing the storage drive from the bracket

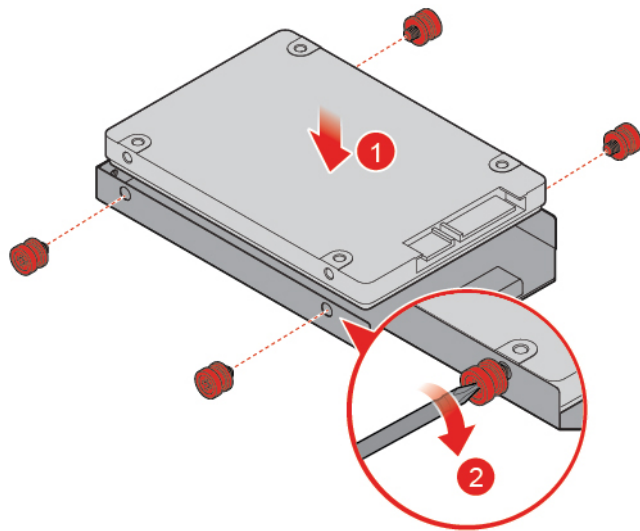

Figure 20. Installing the storage drive into the bracket



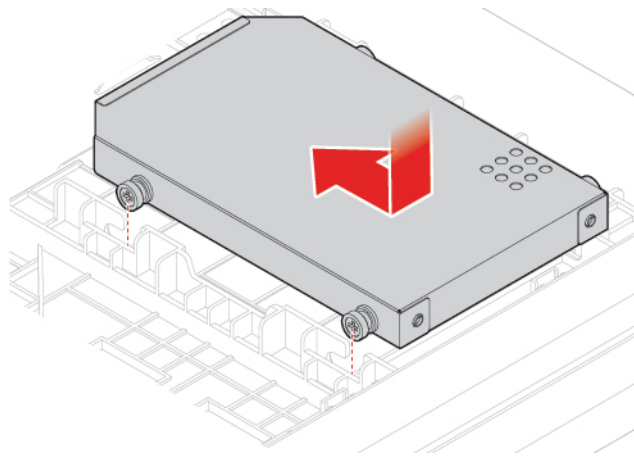

Figure 21. Installing the storage drive and the bracket

5. Connect the signal cable and the power cable to the new storage drive.
6. Reinstall the removed parts. To complete the replacement, see “Completing the parts replacement” on page 55.

---

## Replacing the optical drive

**Attention:** Do not open your computer or attempt any repairs before reading the *Important Product Information Guide*.

1. Remove the computer stand. See “Replacing the computer stand” on page 16.
2. Remove the computer cover. See “Removing the computer cover” on page 18.
3. Replace the optical drive.

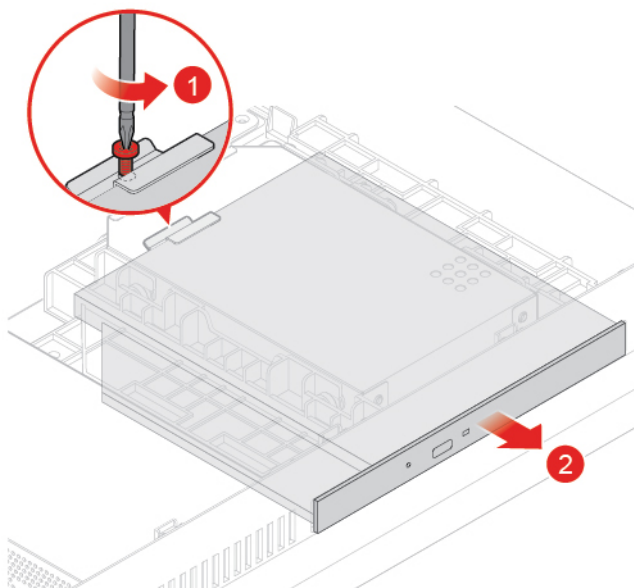

Figure 22. Removing the optical drive

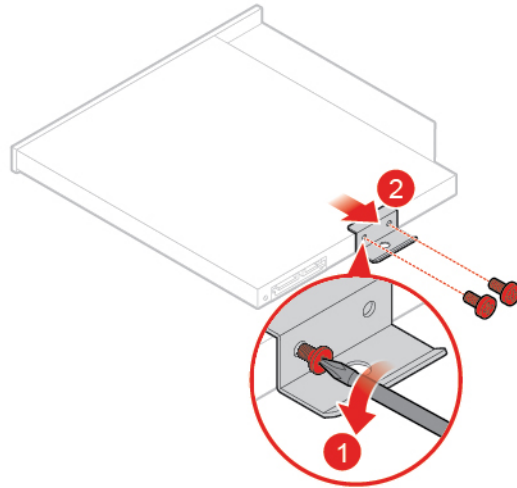

Figure 23. Removing the optical drive holder

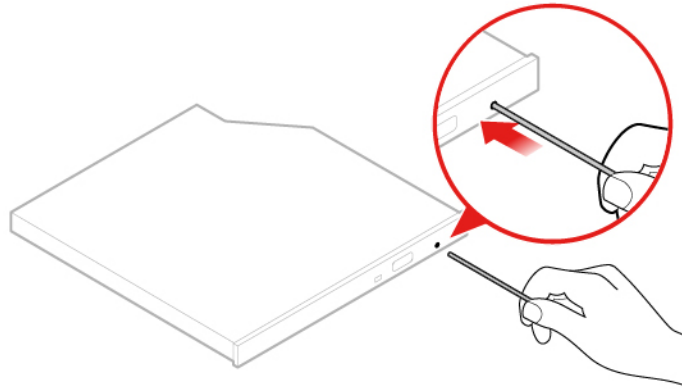

Figure 24. Inserting a straightened paper clip into the emergency-eject hole until the tray slides out

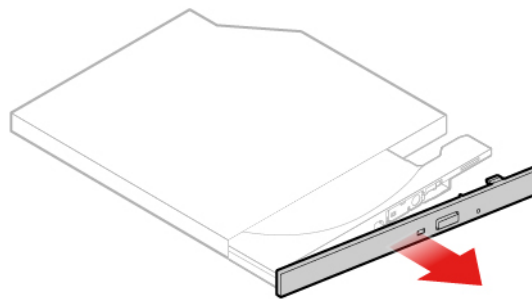

Figure 25. Removing the optical drive bezel

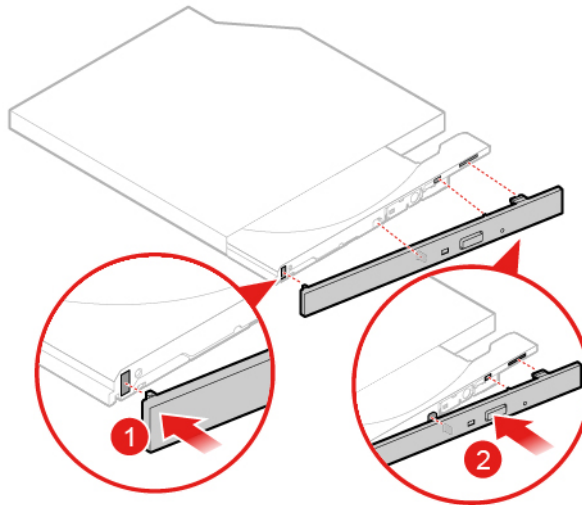

Figure 26. Installing the optical drive bezel

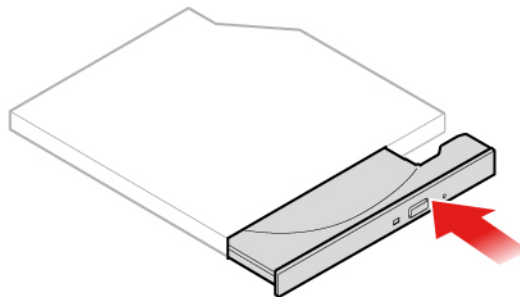

Figure 27. Closing the tray

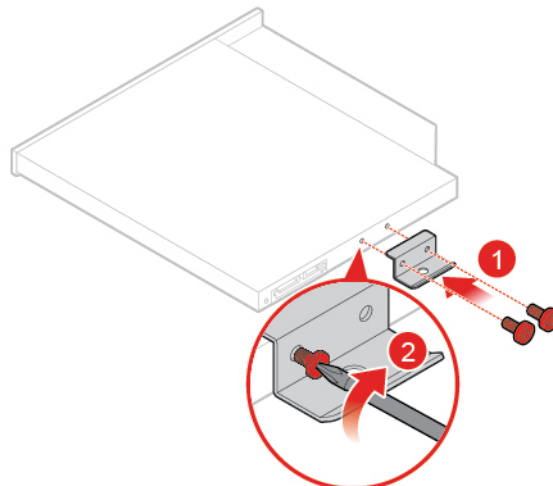

Figure 28. Installing the optical drive holder

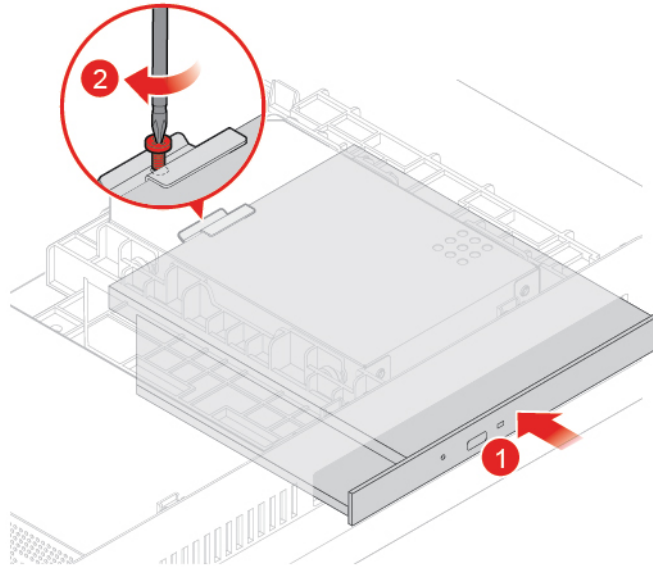

Figure 29. Installing the optical drive

4. Reinstall the removed parts. To complete the replacement, see “Completing the parts replacement” on page 55.

---

## Replacing the optical drive and storage drive cables

**Attention:** Do not open your computer or attempt any repairs before reading the *Important Product Information Guide*.

1. Remove the computer stand. See “Replacing the computer stand” on page 16.
2. Remove the computer cover. See “Removing the computer cover” on page 18.
3. Remove the optical drive. See “Replacing the optical drive” on page 21.
4. Disconnect the optical drive and storage drive cables from the storage drive and the system board.
5. Replace the optical drive and storage drive cables.

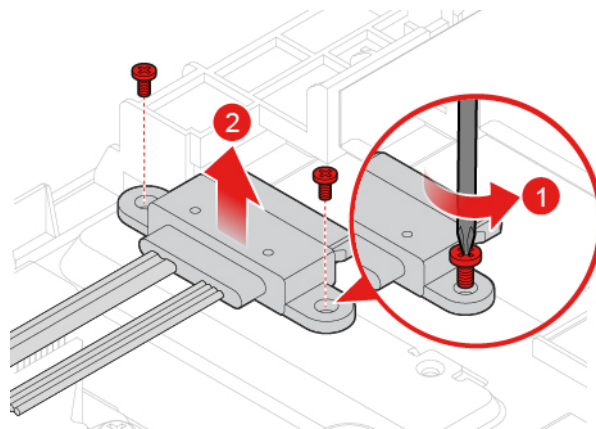

Figure 30. Removing the optical drive and storage drive cables

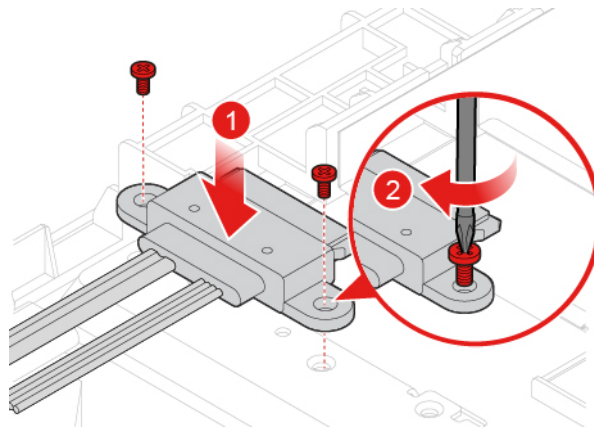

Figure 31. Installing the optical drive and storage drive cables

6. Connect the new optical drive and storage drive cables to the storage drive and the system board.
7. Reinstall the removed parts. To complete the replacement, see “Completing the parts replacement” on page 55.

---

## Replacing the side I/O bezel

**Attention:** Do not open your computer or attempt any repairs before reading the *Important Product Information Guide*.

1. Remove the computer stand. See “Replacing the computer stand” on page 16.
2. Remove the computer cover. See “Removing the computer cover” on page 18.
3. Replace the side I/O bezel.

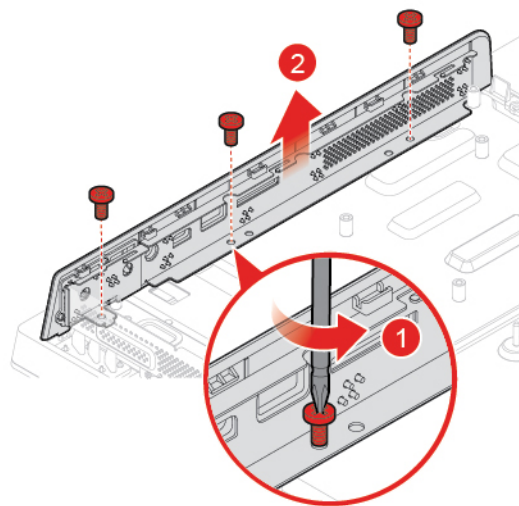

Figure 32. Removing the side I/O bezel

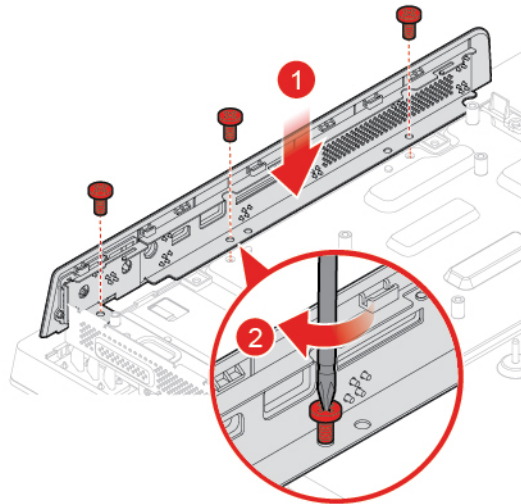

Figure 33. Installing the side I/O bezel

4. Reinstall the removed parts. To complete the replacement, see “Completing the parts replacement” on page 55.

---

## Replacing the system board shield

**Attention:** Do not open your computer or attempt any repairs before reading the *Important Product Information Guide*.

1. Remove the computer stand. See “Replacing the computer stand” on page 16.
2. Remove the computer cover. See “Removing the computer cover” on page 18.
3. Remove the side I/O bezel. See “Replacing the side I/O bezel” on page 25.
4. Replace the system board shield.

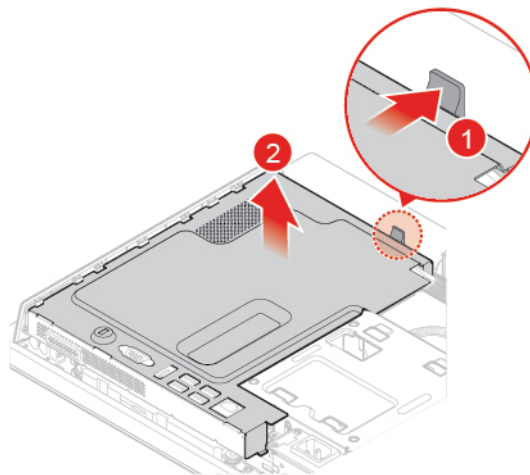

Figure 34. Removing the system board shield

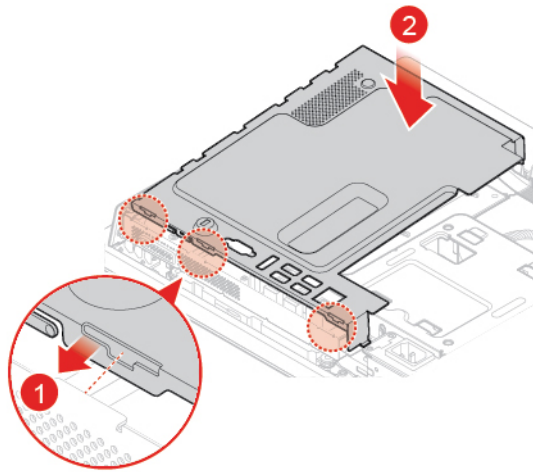

Figure 35. Installing the system board shield

5. Reinstall the removed parts. To complete the replacement, see “Completing the parts replacement” on page 55.

---

## Replacing the VESA mount bracket

**Attention:** Do not open your computer or attempt any repairs before reading the *Important Product Information Guide*.

1. Remove the computer stand. See “Replacing the computer stand” on page 16.
2. Remove the computer cover. See “Removing the computer cover” on page 18.
3. Remove the side I/O bezel. See “Replacing the side I/O bezel” on page 25.
4. Remove the system board shield. See “Replacing the system board shield” on page 26.
5. Replace the VESA mount bracket.

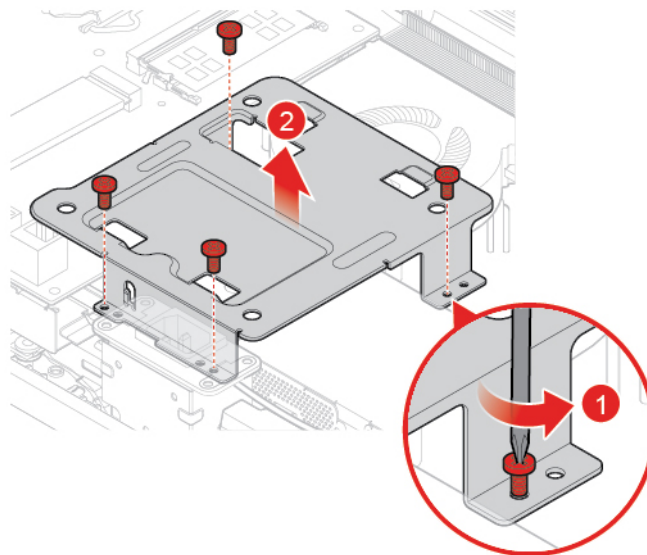

Figure 36. Removing the VESA mount bracket

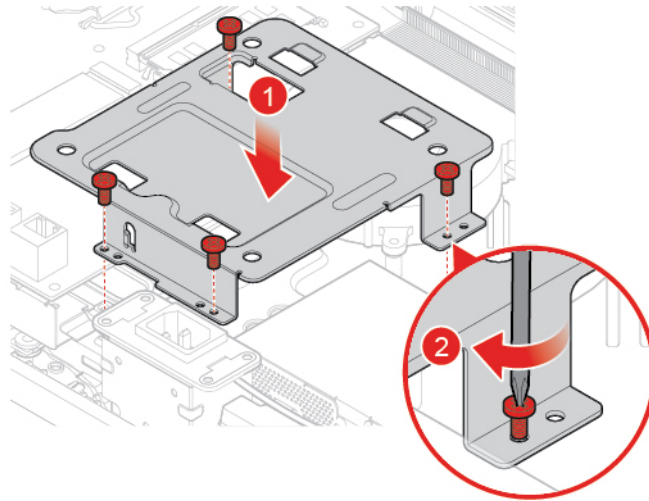

Figure 37. Installing the VESA mount bracket

6. Reinstall the removed parts. To complete the replacement, see “Completing the parts replacement” on page 55.

---

## Replacing the power supply assembly

**Attention:** Do not open your computer or attempt any repairs before reading the *Important Product Information Guide*.

Although there are no moving parts in the computer after the power cord has been disconnected, the following warnings are required for your safety and proper Underwriters Laboratories (UL) certification.

**CAUTION:**

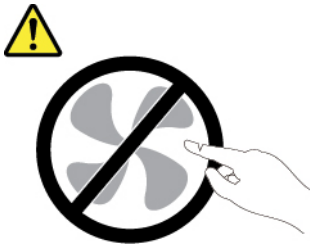

**Hazardous moving parts. Keep fingers and other body parts away.**

**CAUTION:**

**Never remove the cover on a power supply or any part that has the following label attached.**





**Hazardous voltage, current, and energy levels are present inside any component that has this label attached. There are no serviceable parts inside these components. If you suspect a problem with one of these parts, contact a service technician.**

1. Remove the computer stand. See “Replacing the computer stand” on page 16.
2. Remove the computer cover. See “Removing the computer cover” on page 18.
3. Remove the side I/O bezel. See “Replacing the side I/O bezel” on page 25.
4. Remove the system board shield. See “Replacing the system board shield” on page 26.
5. Remove the VESA mount bracket. See “Replacing the VESA mount bracket” on page 27.
6. Disconnect the power supply assembly cable from the system board.
7. Replace the power supply assembly.

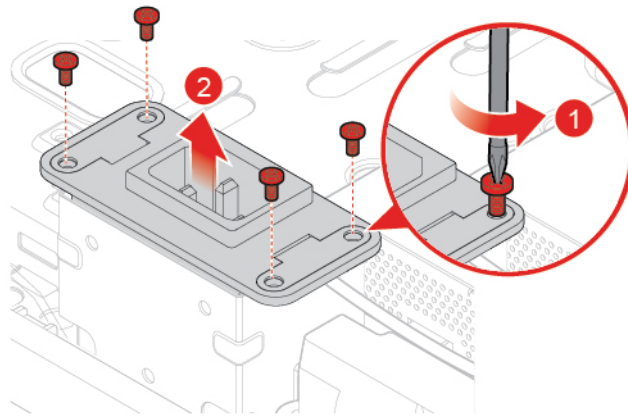

Figure 38. Removing the power cord connector

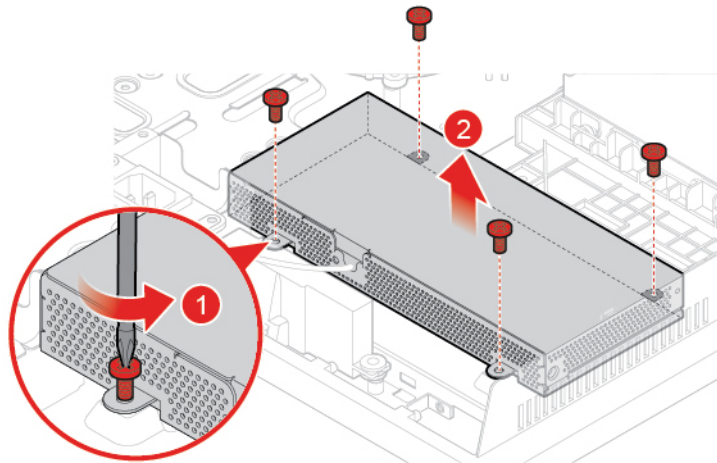

Figure 39. Removing the power supply assembly

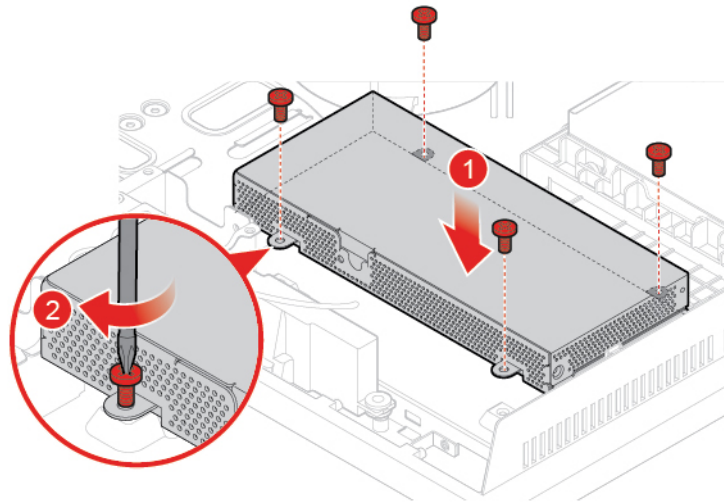

Figure 40. Installing the power supply assembly

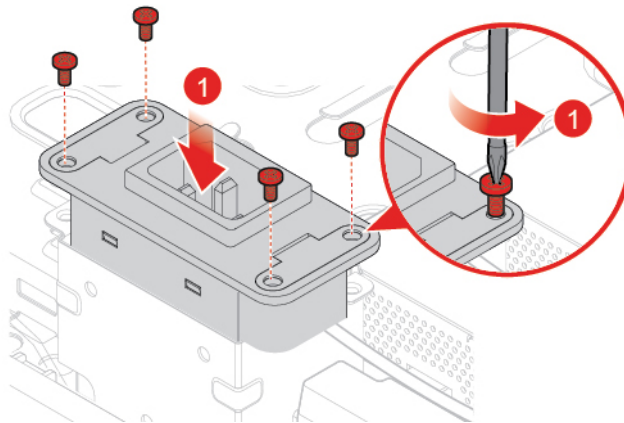

Figure 41. Installing the power cord connector

8. Connect the new power supply assembly cable to the system board.
9. Reinstall the removed parts. To complete the replacement, see “Completing the parts replacement” on page 55.

---

## Replacing the cover presence switch

**Attention:** Do not open your computer or attempt any repairs before reading the *Important Product Information Guide*.

1. Remove the computer stand. See “Replacing the computer stand” on page 16.
2. Remove the computer cover. See “Removing the computer cover” on page 18.
3. Remove the side I/O bezel. See “Replacing the side I/O bezel” on page 25.
4. Remove the system board shield. See “Replacing the system board shield” on page 26.
5. Remove the VESA mount bracket. See “Replacing the VESA mount bracket” on page 27.
6. Remove the power cord connector. See “Replacing the power supply assembly” on page 28.
7. Disconnect the cover presence switch cable from the system board.
8. Replace the cover presence switch.

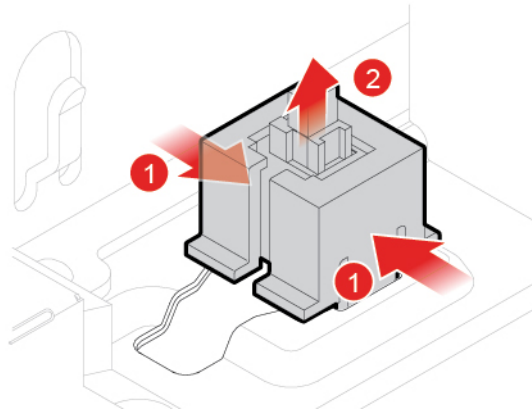

Figure 42. Removing the cover presence switch and the bracket

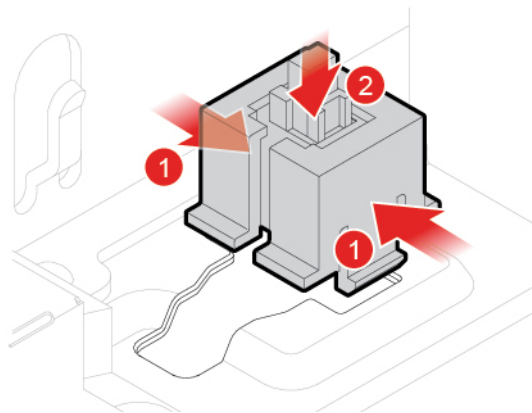

Figure 43. Installing the cover presence switch and the bracket

9. Connect the new cover presence switch cable to the system board.
10. Reinstall the removed parts. To complete the replacement, see “Completing the parts replacement” on page 55.

---

## Replacing the system fan

**Attention:** Do not open your computer or attempt any repairs before reading the *Important Product Information Guide*.

1. Remove the computer stand. See “Replacing the computer stand” on page 16.
2. Remove the computer cover. See “Removing the computer cover” on page 18.
3. Remove the side I/O bezel. See “Replacing the side I/O bezel” on page 25.
4. Remove the system board shield. See “Replacing the system board shield” on page 26.
5. Remove the VESA mount bracket. See “Replacing the VESA mount bracket” on page 27.
6. Disconnect the system fan cable from the system board.
7. Replace the system fan.

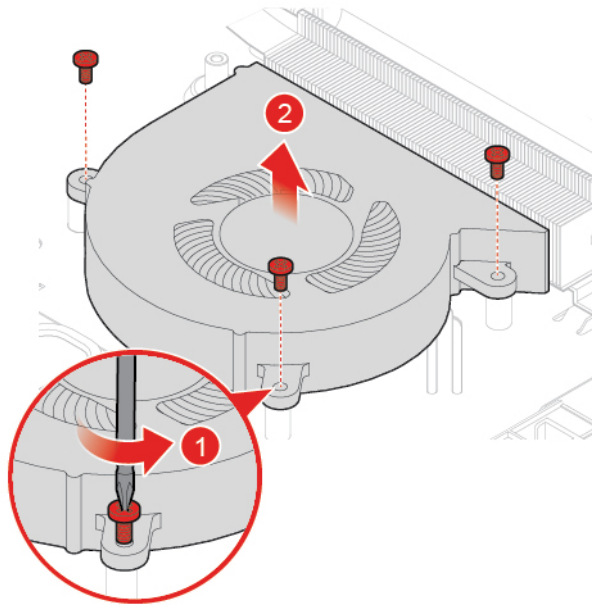

Figure 44. Removing the system fan

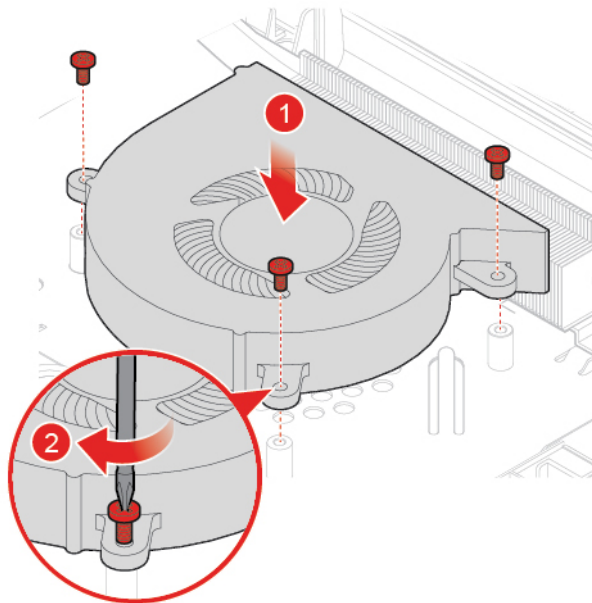

Figure 45. Installing the system fan

8. Connect the new system fan cable to the system board.
9. Reinstall the removed parts. To complete the replacement, see “Completing the parts replacement” on page 55.

---

## Replacing the heat sink

**Attention:** Do not open your computer or attempt any repairs before reading the *Important Product Information Guide*.

**CAUTION:**



**The heat sink might be very hot. Before you open the computer cover, turn off the computer and wait several minutes until the computer is cool.**

1. Remove the computer stand. See “Replacing the computer stand” on page 16.
2. Remove the computer cover. See “Removing the computer cover” on page 18.
3. Remove the side I/O bezel. See “Replacing the side I/O bezel” on page 25.
4. Remove the system board shield. See “Replacing the system board shield” on page 26.
5. Replace the heat sink.

**Notes:**

- Carefully remove the screws from the system board to avoid any possible damage to the system board. The screws cannot be removed from the heat sink.
- You might have to gently twist the heat sink to free it from the microprocessor.
- Do not touch the thermal grease while handling the heat sink.

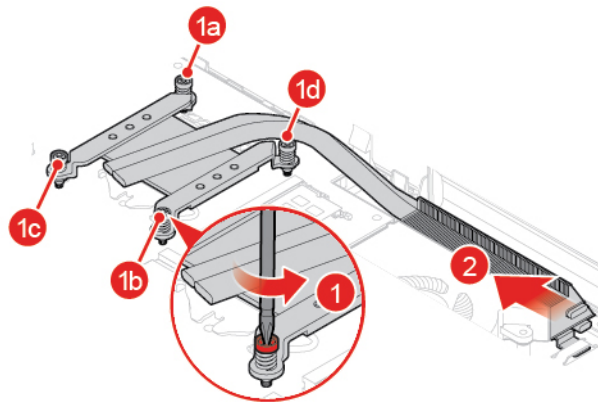

Figure 46. Removing the heat sink

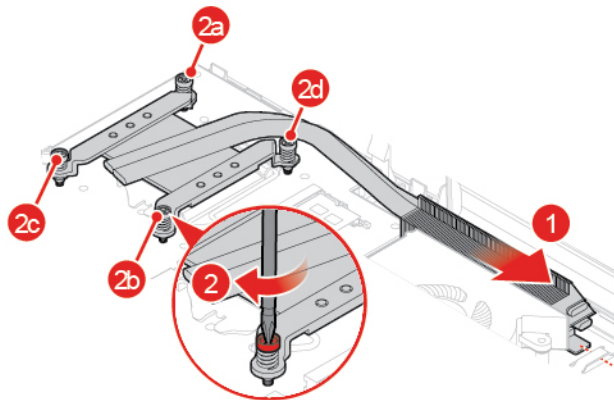

Figure 47. Installing the heat sink

6. Reinstall the removed parts. To complete the replacement, see “Completing the parts replacement” on page 55.

---

## Replacing the microprocessor

**Attention:** Do not open your computer or attempt any repairs before reading the *Important Product Information Guide*.

**CAUTION:**



**The heat sink might be very hot. Before you open the computer cover, turn off the computer and wait several minutes until the computer is cool.**

1. Remove the computer stand. See “Replacing the computer stand” on page 16.
2. Remove the computer cover. See “Removing the computer cover” on page 18.
3. Remove the side I/O bezel. See “Replacing the side I/O bezel” on page 25.
4. Remove the system board shield. See “Replacing the system board shield” on page 26.
5. Remove the heat sink. See “Replacing the heat sink” on page 32.
6. Record the cable routing and cable connections, and then disconnect all cables from the system board. See “System board” on page 4.
7. Replace the microprocessor.

**Notes:**

- Your microprocessor and socket might look different from the one illustrated.
- Touch only the edges of the microprocessor. Do not touch the gold contacts on the bottom.
- Do not drop anything onto the microprocessor socket while it is exposed. The socket pins must be kept as clean as possible.

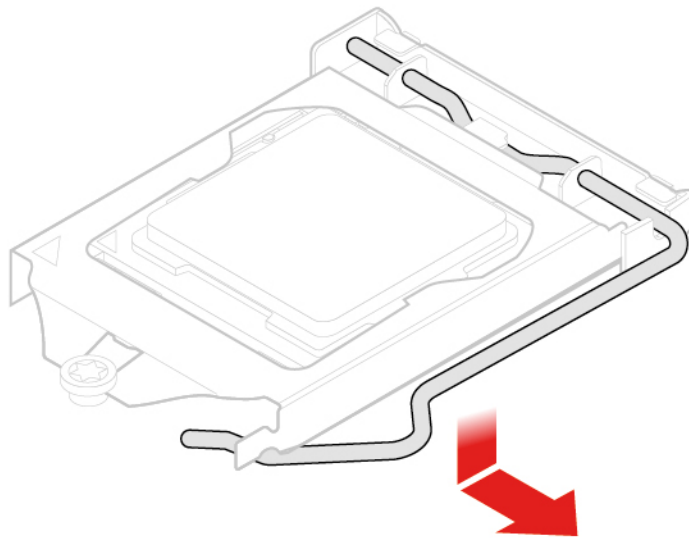

Figure 48. Releasing the handle

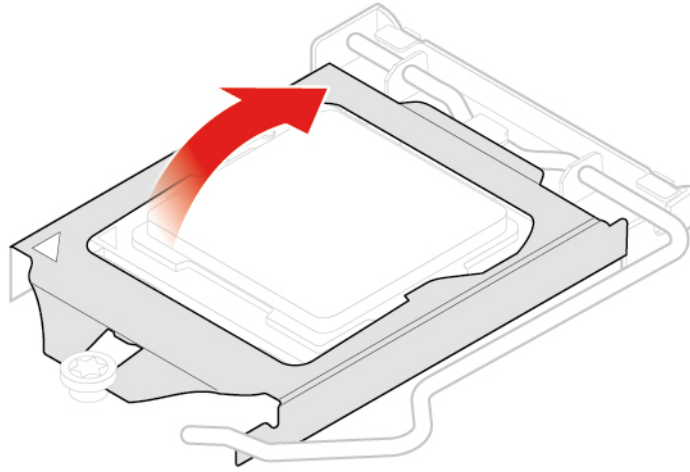

Figure 49. Opening the retainer

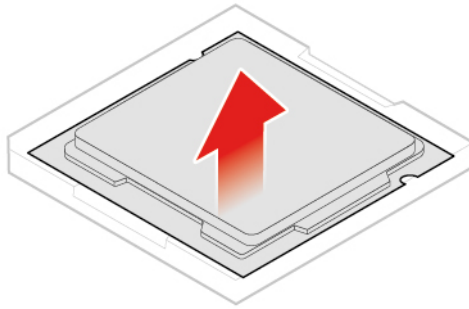

Figure 50. Removing the microprocessor

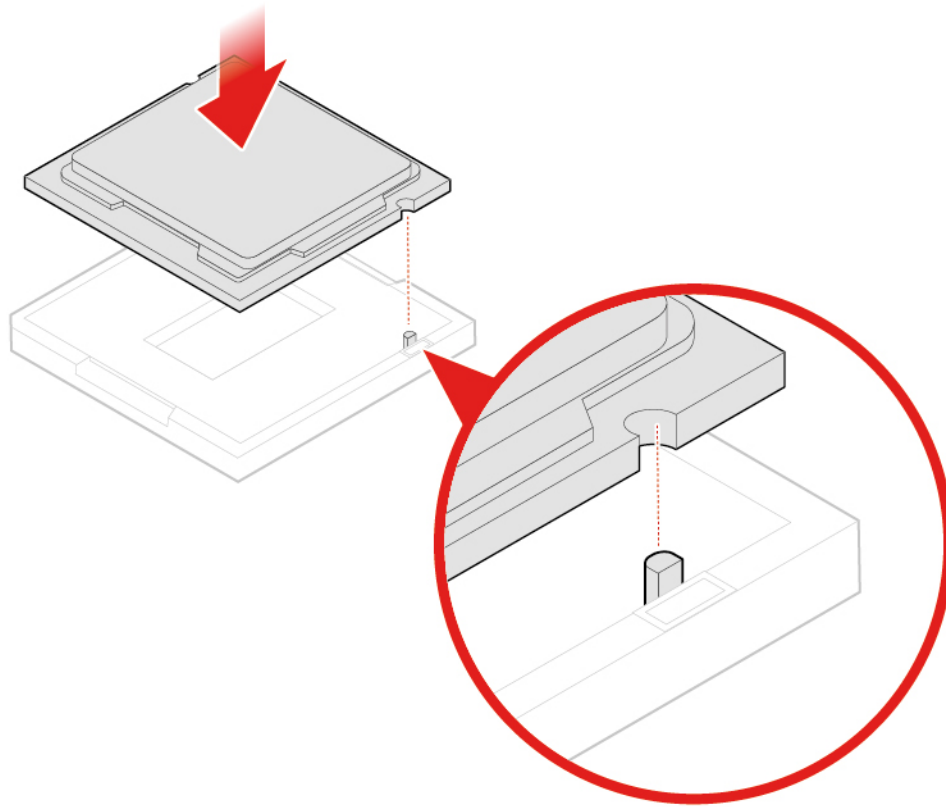

Figure 51. Installing the microprocessor



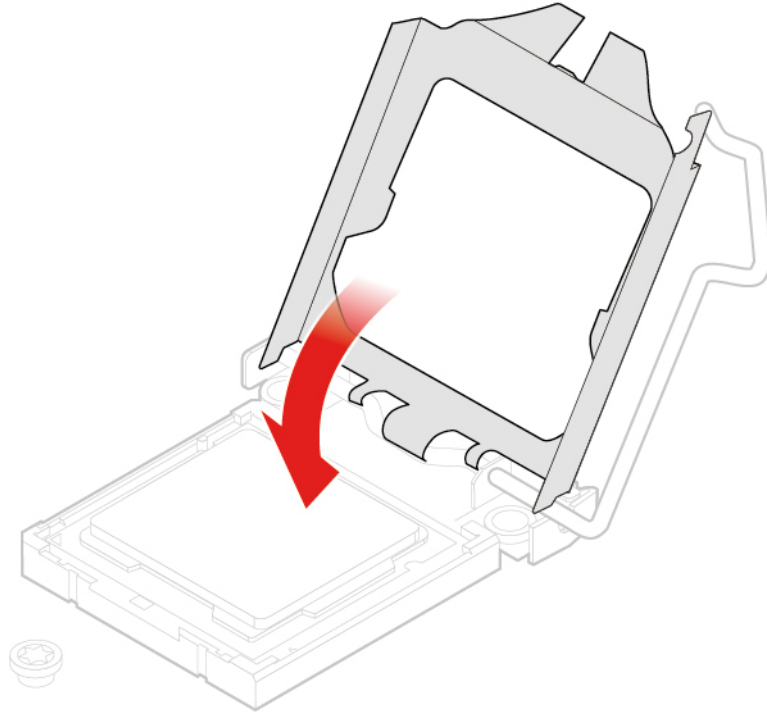

Figure 52. Closing the retainer

8.

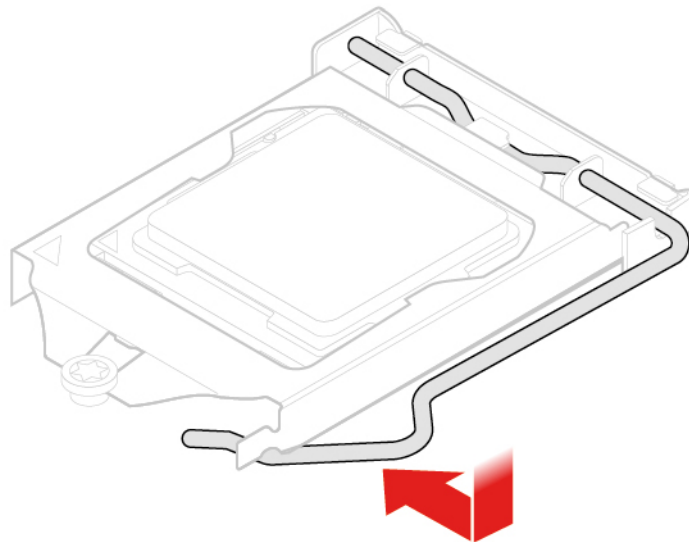

Figure 53. Securing the retainer with the handle

9. Route all the cables that you disconnected from the system board, and then reconnect the cables to the system board.
10. Reinstall the removed parts. To complete the replacement, see “Completing the parts replacement” on page 55.

## Replacing the Wi-Fi card

**Attention:** Do not open your computer or attempt any repairs before reading the *Important Product Information Guide*.

1. Remove the computer stand. See “Replacing the computer stand” on page 16.
2. Remove the computer cover. See “Removing the computer cover” on page 18.
3. Remove the side I/O bezel. See “Replacing the side I/O bezel” on page 25.
4. Remove the system board shield. See “Replacing the system board shield” on page 26.
5. Replace the Wi-Fi card.

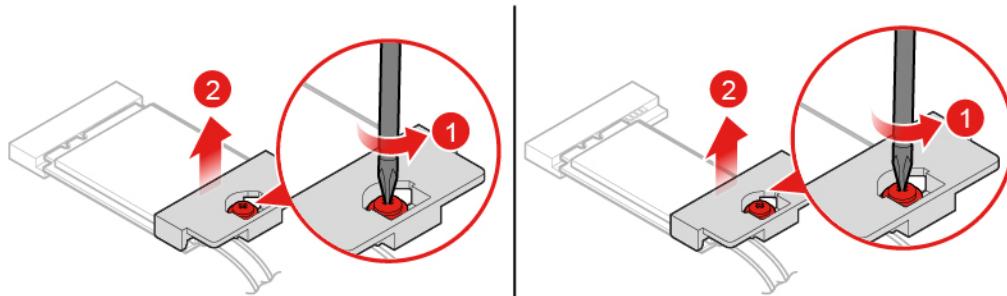

Figure 54. Removing the Wi-Fi card shield

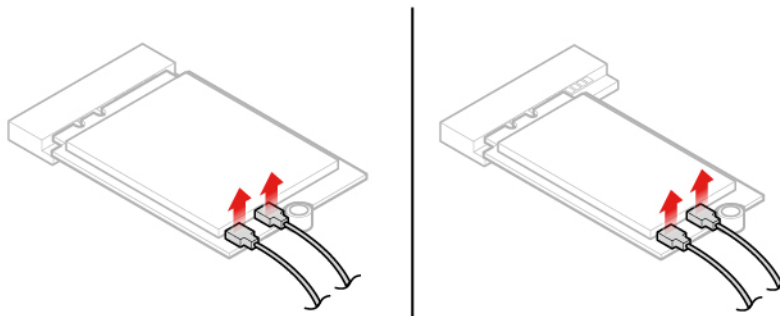

Figure 55. Disconnecting the Wi-Fi antenna cables

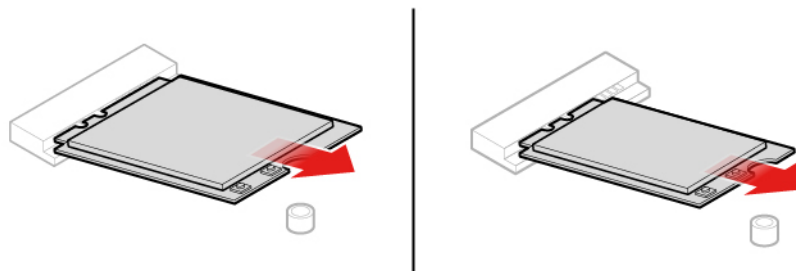

Figure 56. Removing the Wi-Fi card

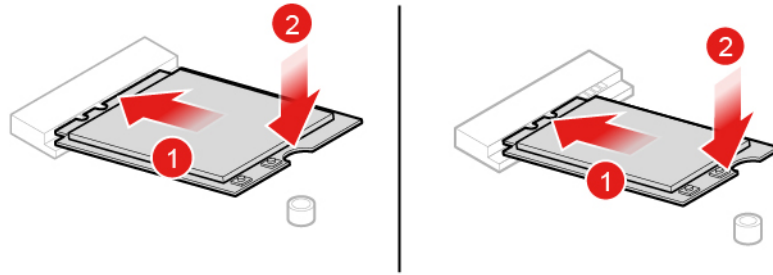

Figure 57. Installing the Wi-Fi card

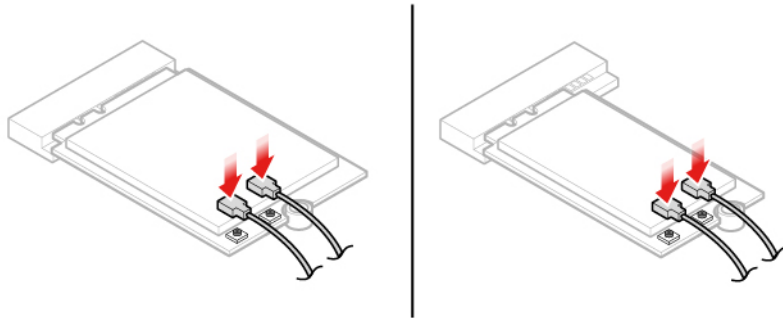

Figure 58. Connecting the Wi-Fi antenna cables

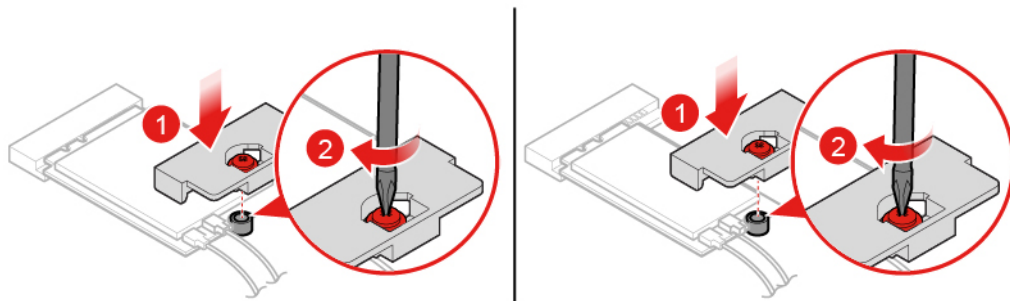

Figure 59. Installing the Wi-Fi card shield

6. Reinstall the removed parts. To complete the replacement, see “Completing the parts replacement” on page 55.

## Replacing the serial connector module

**Attention:** Do not open your computer or attempt any repairs before reading the *Important Product Information Guide*.

1. Remove the computer stand. See “Replacing the computer stand” on page 16.
2. Remove the computer cover. See “Removing the computer cover” on page 18.
3. Remove the side I/O bezel. See “Replacing the side I/O bezel” on page 25.
4. Remove the system board shield. See “Replacing the system board shield” on page 26.
5. Replace the serial connector module.

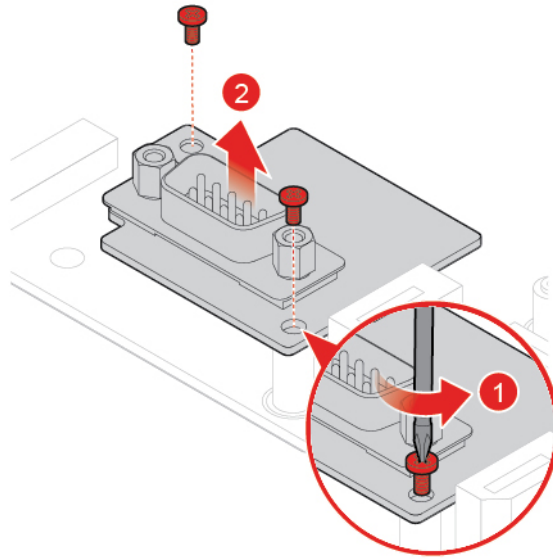

Figure 60. Removing the serial connector module

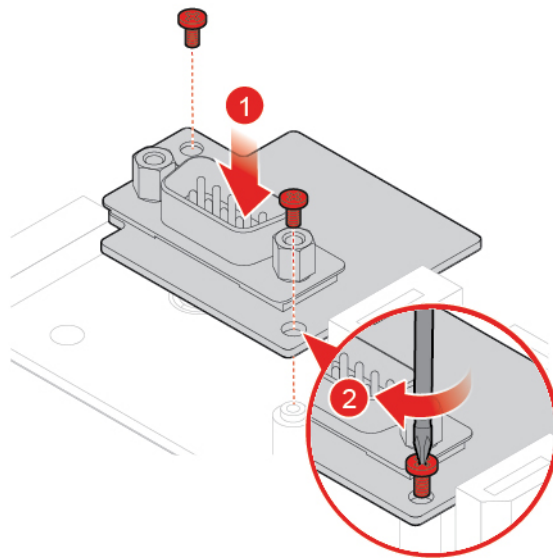

Figure 61. Installing the serial connector module

6. Reinstall the removed parts. To complete the replacement, see “Completing the parts replacement” on page 55.

---

## Replacing the M.2 solid-state drive

**Attention:** Do not open your computer or attempt any repairs before reading the *Important Product Information Guide*.

1. Remove the computer stand. See “Replacing the computer stand” on page 16.
2. Remove the computer cover. See “Removing the computer cover” on page 18.
3. Remove the side I/O bezel. See “Replacing the side I/O bezel” on page 25.
4. Remove the system board shield. See “Replacing the system board shield” on page 26.

5. Depending on your computer model, refer to one of the following to replace the M.2 solid-state drive.
- Type 1

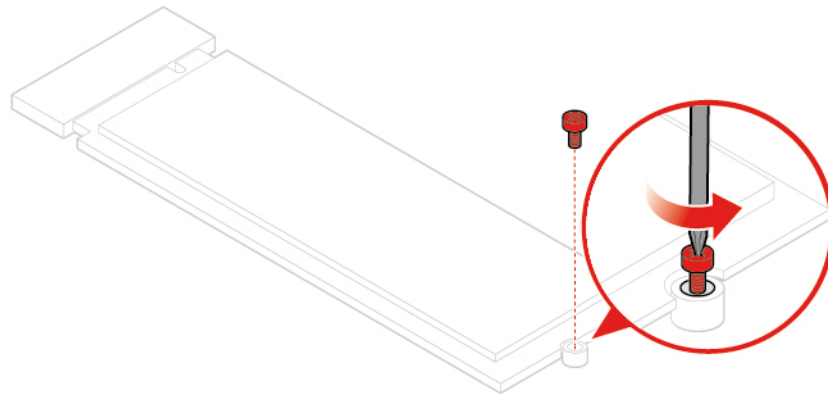

Figure 62. Removing the screw

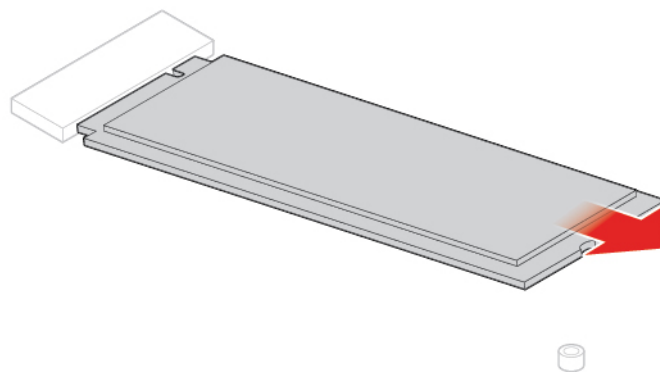

Figure 63. Removing the M.2 solid-state drive

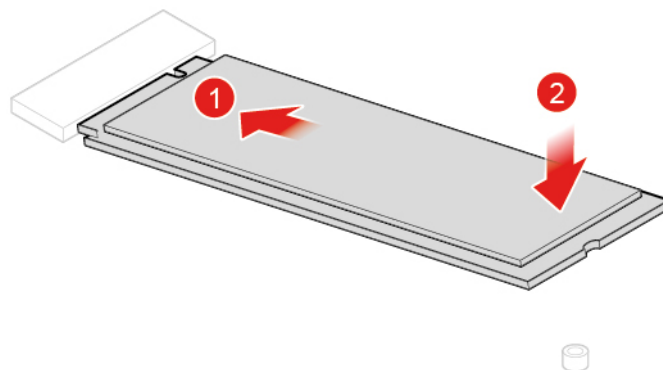

Figure 64. Installing the M.2 solid-state drive

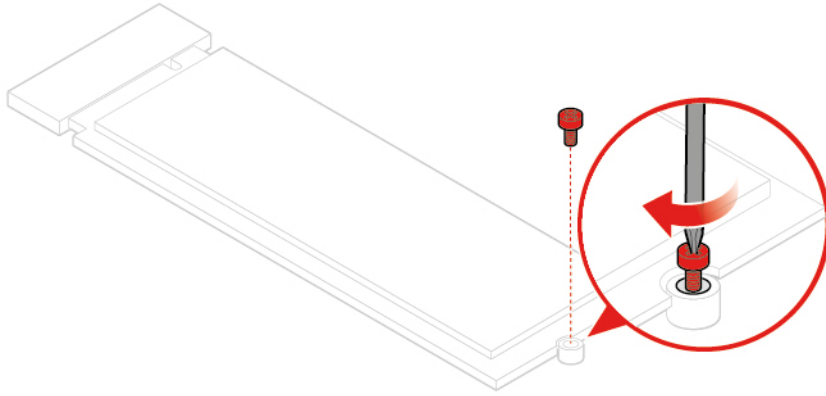

Figure 65. Installing the screw

- Type 2

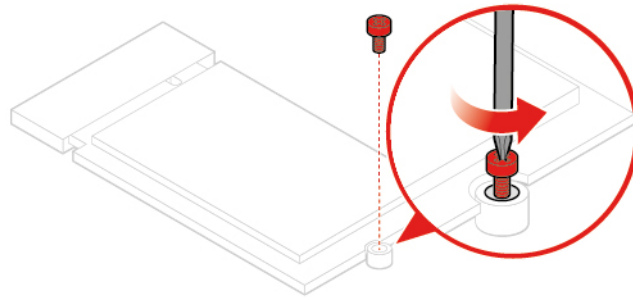

Figure 66. Removing the screw

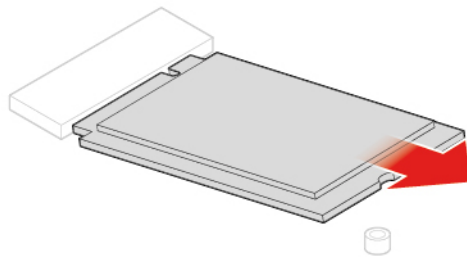

Figure 67. Removing the M.2 solid-state drive

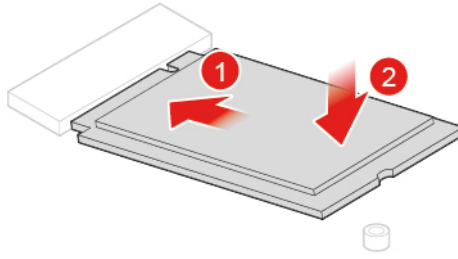

Figure 68. Installing the M.2 solid-state drive

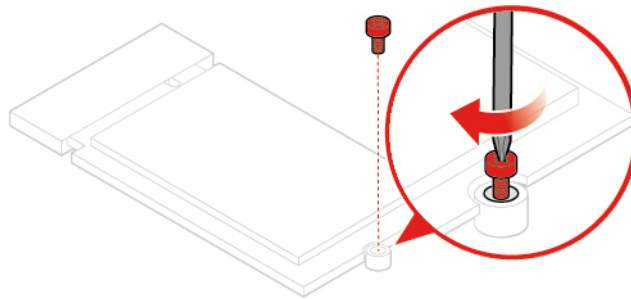

Figure 69. Installing the screw

6. Reinstall the removed parts. To complete the replacement, see “Completing the parts replacement” on page 55.

---

## Replacing a memory module

**Attention:** Do not open your computer or attempt any repairs before reading the *Important Product Information Guide*.

Ensure that you follow the installation order for memory modules shown in the following figure.

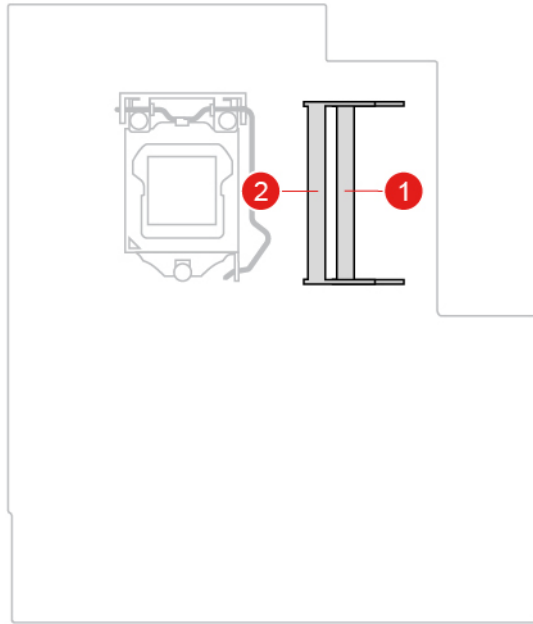

1. Remove the computer stand. See “Replacing the computer stand” on page 16.
2. Remove the computer cover. See “Removing the computer cover” on page 18.
3. Remove the side I/O bezel. See “Replacing the side I/O bezel” on page 25.
4. Remove the system board shield. See “Replacing the system board shield” on page 26.
5. Replace a memory module.

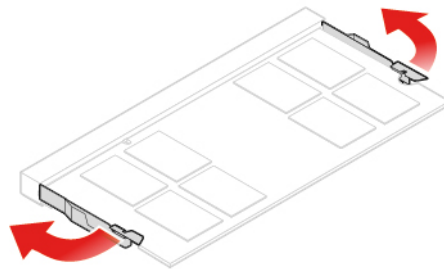

*Figure 70. Disengaging the latches*

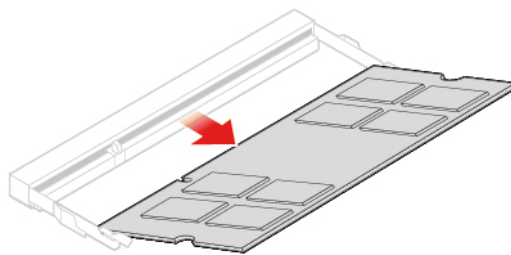

*Figure 71. Removing a memory module*



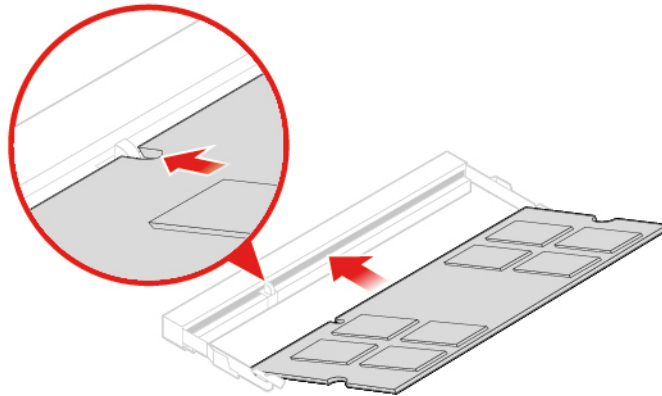

Figure 72. Installing a memory module

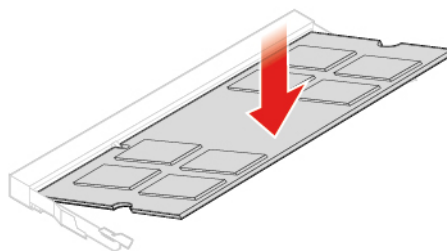

Figure 73. Securing a memory module with the latches

6. Reinstall the removed parts. To complete the replacement, see “Completing the parts replacement” on page 55.

---

## Replacing the coin-cell battery

**Attention:** Do not open your computer or attempt any repairs before reading the *Important Product Information Guide*.

**Note:** To dispose of the coin-cell battery, refer to “Lithium coin-cell battery notice” in the *Safety and Warranty Guide*.

Your computer has a special type of memory that maintains the date, time, and settings for built-in features, such as parallel connector assignments (configurations). A coin-cell battery keeps this information active when you turn off the computer.

The coin-cell battery normally requires no charging or maintenance throughout its life; however, no coin-cell battery lasts forever. If the coin-cell battery fails, the date, time, and configuration information (including passwords) are lost. An error message is displayed when you turn on the computer.

1. Remove the computer stand. See “Replacing the computer stand” on page 16.
2. Remove the computer cover. See “Removing the computer cover” on page 18.
3. Remove the side I/O bezel. See “Replacing the side I/O bezel” on page 25.
4. Remove the system board shield. See “Replacing the system board shield” on page 26.
5. Replace the coin-cell battery.

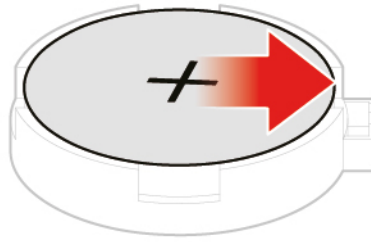

Figure 74. Disengaging the latch

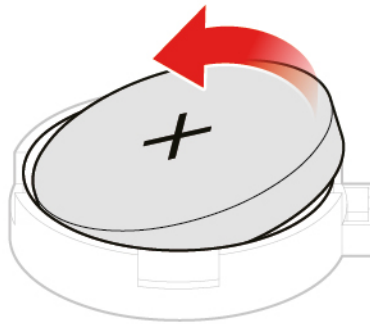

Figure 75. Removing the coin-cell battery

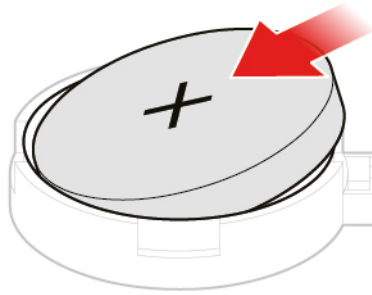

Figure 76. Installing the coin-cell battery

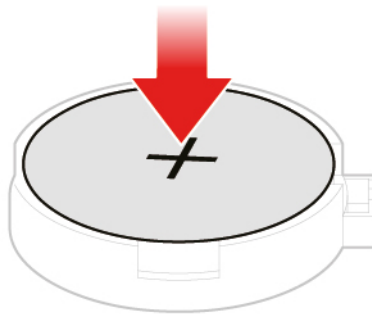

Figure 77. Securing the coin-cell battery with the latch

6. Reinstall the removed parts. To complete the replacement, see “Completing the parts replacement” on page 55.

---

## Replacing the card reader

**Attention:** Do not open your computer or attempt any repairs before reading the *Important Product Information Guide*.

1. Remove the computer stand. See “Replacing the computer stand” on page 16.
2. Remove the computer cover. See “Removing the computer cover” on page 18.
3. Remove the side I/O bezel. See “Replacing the side I/O bezel” on page 25.
4. Remove the system board shield. See “Replacing the system board shield” on page 26.
5. Disconnect the card reader cable from the system board.
6. Replace the card reader.

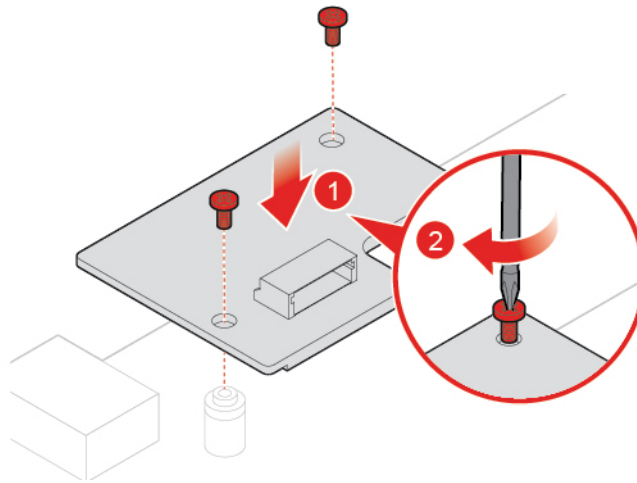

Figure 78. Removing the card reader

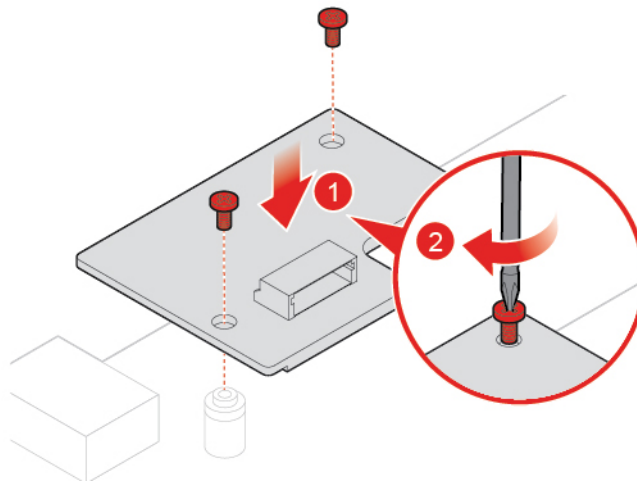

Figure 79. Installing the card reader

7. Connect the new card reader cable to the system board.
8. Reinstall the removed parts. To complete the replacement, see “Completing the parts replacement” on page 55.

---

## Replacing the system board

**Attention:** Do not open your computer or attempt any repairs before reading the *Important Product Information Guide*.

1. Remove the computer stand. See “Replacing the computer stand” on page 16.
2. Remove the computer cover. See “Removing the computer cover” on page 18.
3. Remove the side I/O bezel. See “Replacing the side I/O bezel” on page 25.
4. Remove the system board shield. See “Replacing the system board shield” on page 26.
5. Remove the VESA mount bracket. See “Replacing the VESA mount bracket” on page 27.
6. Remove the heat sink. See “Replacing the heat sink” on page 32.
7. Remove the microprocessor. See “Replacing the microprocessor” on page 34.
8. Remove the Wi-Fi card. See “Replacing the Wi-Fi card” on page 38.

9. Remove the serial connector module. See “Replacing the serial connector module” on page 39.
10. Remove the M.2 solid-state drive. See “Replacing the M.2 solid-state drive” on page 40.
11. Remove all memory modules. See “Replacing a memory module” on page 43.
12. Remove the card reader. See “Replacing the card reader” on page 47.
13. Record the cable routing and cable connections, and then disconnect all cables from the system board. See “System board” on page 4.
14. Replace the system board.

**Notes:**

- The numbers in the following figure show the locations of the screws instead of a specific order for removing and reinstalling the screws.
- Handle the system board carefully by its edges.
- The failing system board must be returned with a microprocessor socket cover to protect the pins during shipping and handling.

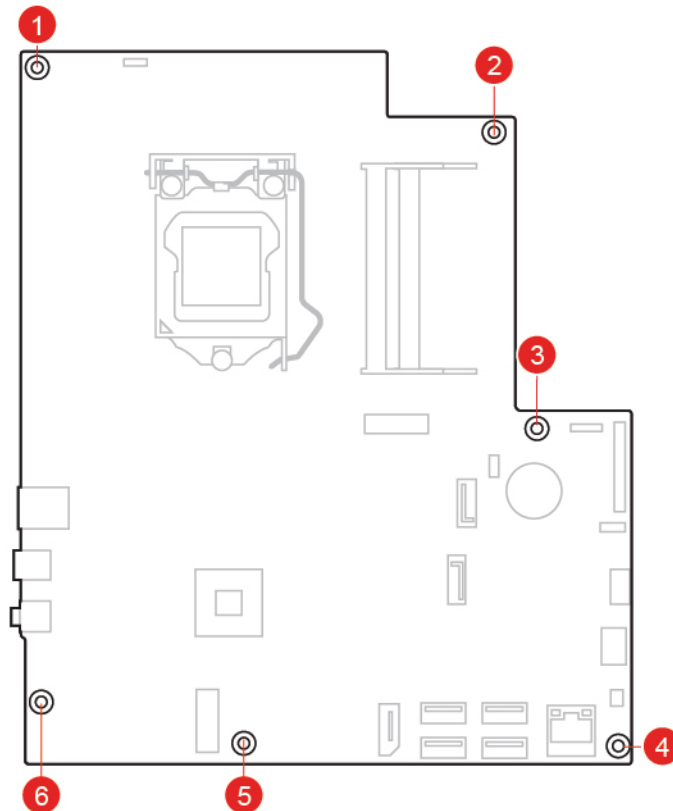

15. Route and connect all the cables to the new system board.
16. Reinstall the removed parts. To complete the replacement, see “Completing the parts replacement” on page 55.

---

## Replacing the integrated camera module

**Attention:** Do not open your computer or attempt any repairs before reading the *Important Product Information Guide*.

1. Remove the computer stand. See “Replacing the computer stand” on page 16.
2. Remove the computer cover. See “Removing the computer cover” on page 18.

3. Remove the side I/O bezel. See “Replacing the side I/O bezel” on page 25.
4. Remove the system board shield. See “Replacing the system board shield” on page 26.
5. Replace the integrated camera module.

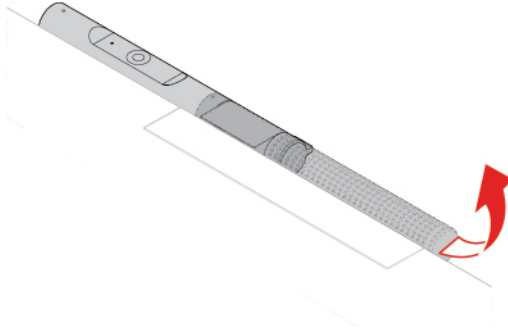

Figure 80. Turning the integrated camera module around

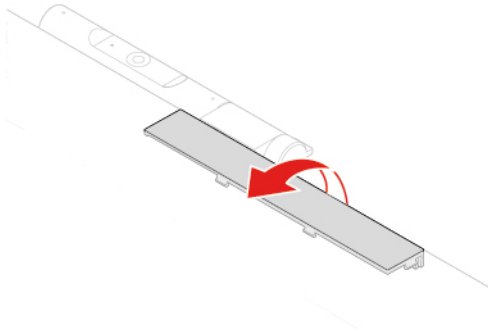

Figure 81. Removing the integrated camera module cover

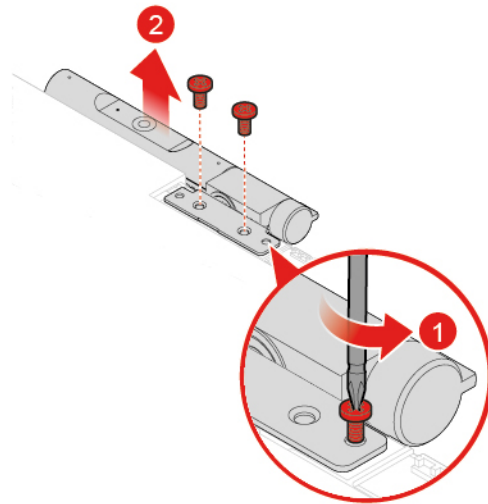

Figure 82. Removing the integrated camera module from the back frame

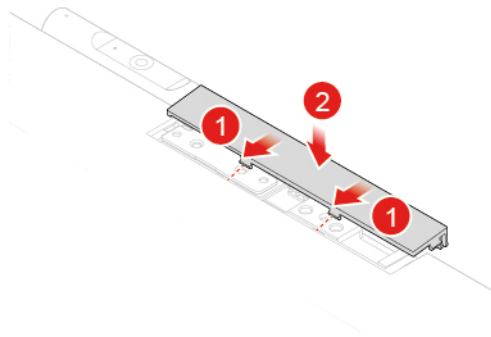

Figure 83. Disconnecting and removing the integrated camera module cable

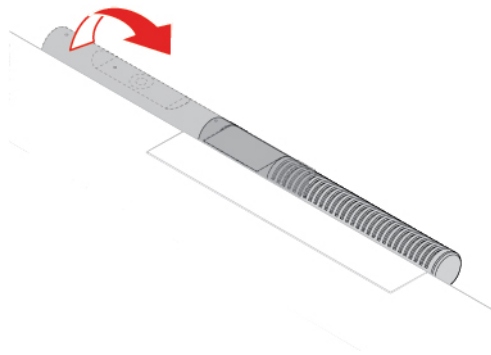

Figure 84. Installing and connecting the integrated camera module cable

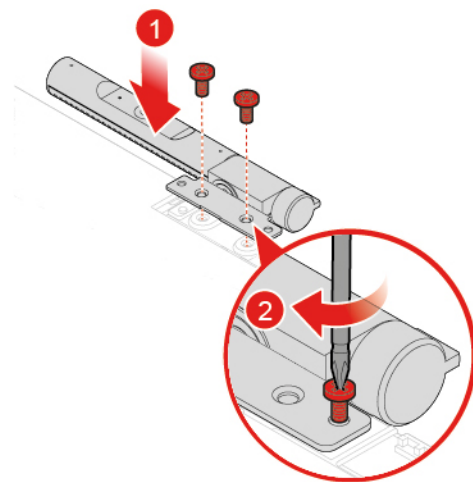

Figure 85. Installing the integrated camera module

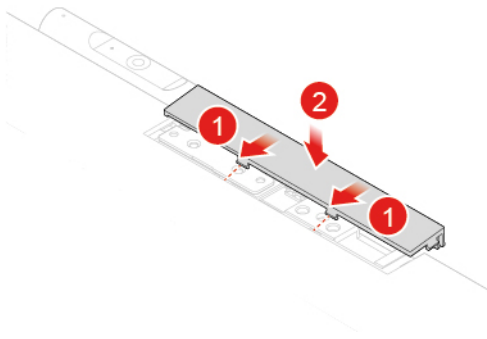

Figure 86. Installing the integrated camera module cover

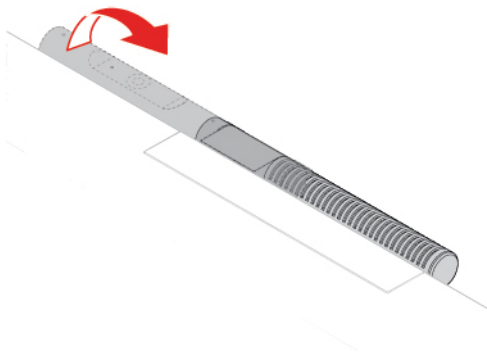

Figure 87. Turning the integrated camera module back

6. Reinstall the removed parts. To complete the replacement, see “Completing the parts replacement” on page 55.

---

## Replacing the internal speakers

**Attention:** Do not open your computer or attempt any repairs before reading the *Important Product Information Guide*.

1. Remove the computer stand. See “Replacing the computer stand” on page 16.
2. Remove the computer cover. See “Removing the computer cover” on page 18.
3. Remove the side I/O bezel. See “Replacing the side I/O bezel” on page 25.
4. Remove the system board shield. See “Replacing the system board shield” on page 26.
5. Remove the VESA mount bracket. See “Replacing the VESA mount bracket” on page 27.
6. Remove the power cord connector. See “Replacing the power supply assembly” on page 28.
7. Remove the heat sink. See “Replacing the heat sink” on page 32.
8. Remove the system board. See “Replacing the system board” on page 48.
9. Remove the system board shielding fence, the side I/O bracket, and the back frame. See “Replacing the integrated camera module” on page 49.
10. Record the routing of the internal speaker cable, and then disconnect the cable from the system board.
11. Replace the internal speakers.



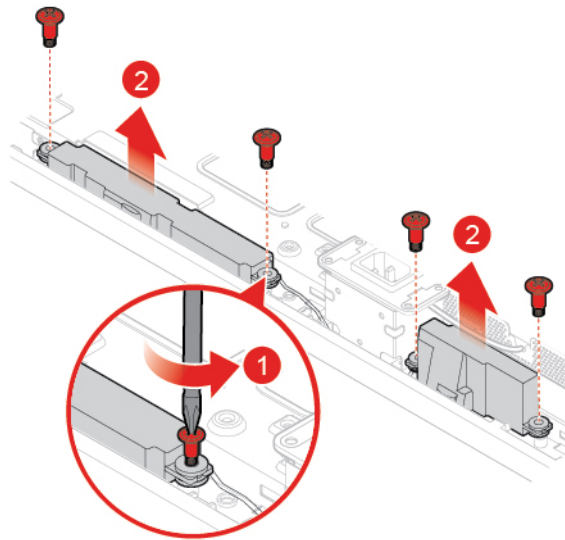

Figure 88. Removing the internal speakers

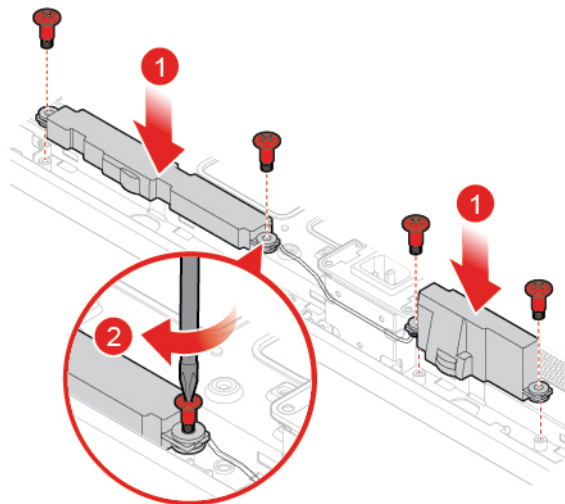

Figure 89. Installing the internal speakers

12. Route the new internal speaker cable, and then connect the cable to the system board.
13. Reinstall the removed parts. To complete the replacement, see “Completing the parts replacement” on page 55.

---

## Replacing the Wi-Fi antennas

**Attention:** Do not open your computer or attempt any repairs before reading the *Important Product Information Guide*.

1. Remove the computer stand. See “Replacing the computer stand” on page 16.
2. Remove the computer cover. See “Removing the computer cover” on page 18.
3. Remove the side I/O bezel. See “Replacing the side I/O bezel” on page 25.
4. Remove the system board shield. See “Replacing the system board shield” on page 26.
5. Remove the VESA mount bracket. See “Replacing the VESA mount bracket” on page 27.
6. Remove the power cord connector. See “Replacing the power supply assembly” on page 28.

7. Remove the heat sink. See “Replacing the heat sink” on page 32.
8. Remove the system board. See “Replacing the system board” on page 48.
9. Remove the system board shielding fence, the side I/O bracket, and the back frame. See “Replacing the integrated camera module” on page 49.
10. Remove the internal speakers. See “Replacing the internal speakers” on page 52.
11. Record the routing of the Wi-Fi antenna cables, and then disconnect the cables from the Wi-Fi card. See “Replacing the Wi-Fi card” on page 38.
12. Replace the Wi-Fi antennas.

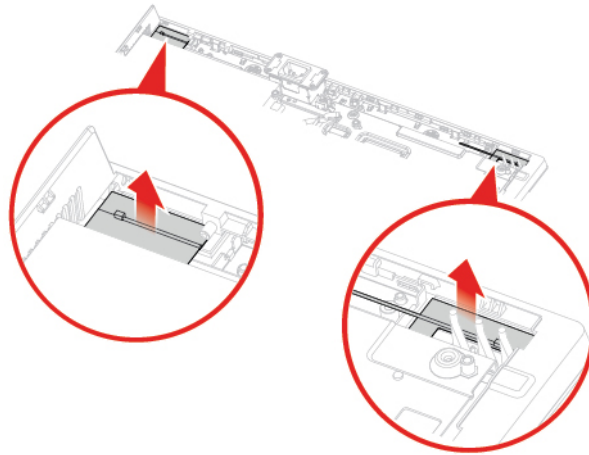

Figure 90. Removing the Wi-Fi antennas

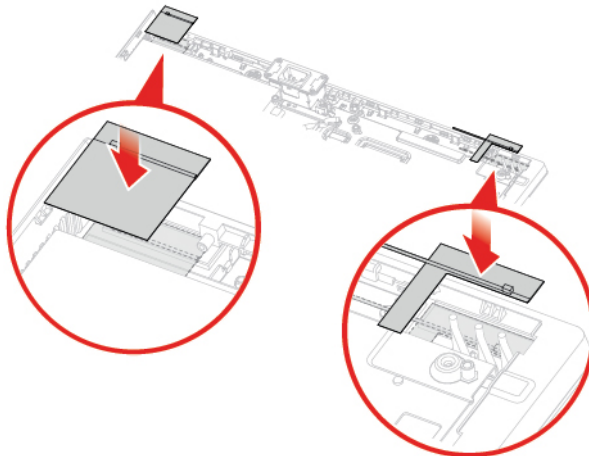

Figure 91. Installing the Wi-Fi antennas

13. Route the new Wi-Fi antenna cables, and then connect the cables to the Wi-Fi card.
14. Reinstall the removed parts. To complete the replacement, see “Completing the parts replacement” on page 55.

---

## Replacing the LCD panel

**Attention:** Do not open your computer or attempt any repairs before reading the *Important Product Information Guide*.

1. Remove the computer stand. See “Replacing the computer stand” on page 16.
2. Remove the computer cover. See “Removing the computer cover” on page 18.
3. Remove the storage drive. See “Replacing the storage drive” on page 19.
4. Remove the optical drive. See “Replacing the optical drive” on page 21.
5. Remove the optical drive cable. See “Replacing the optical drive and storage drive cables” on page 24.
6. Remove the side I/O bezel. See “Replacing the side I/O bezel” on page 25.
7. Remove the system board shield. See “Replacing the system board shield” on page 26.
8. Remove the VESA mount bracket. See “Replacing the VESA mount bracket” on page 27.
9. Remove the power supply assembly. See “Replacing the power supply assembly” on page 28.
10. Remove the cover presence switch. See “Replacing the cover presence switch” on page 30.
11. Remove the system fan. See “Replacing the system fan” on page 31.
12. Remove the heat sink. See “Replacing the heat sink” on page 32.
13. Remove the system board. See “Replacing the system board” on page 48.
14. Remove the integrated camera. See “Replacing the integrated camera module” on page 49.
15. Remove the internal speakers. See “Replacing the internal speakers” on page 52.
16. Remove the Wi-Fi antennas. See “Replacing the Wi-Fi antennas” on page 53.
17. Record the routing of the LCD panel cables, and then disconnect the cables from the system board.
18. Replace the LCD panel.

**Note:** Ensure that you remove and reinstall the screws in order of the numbers as shown.

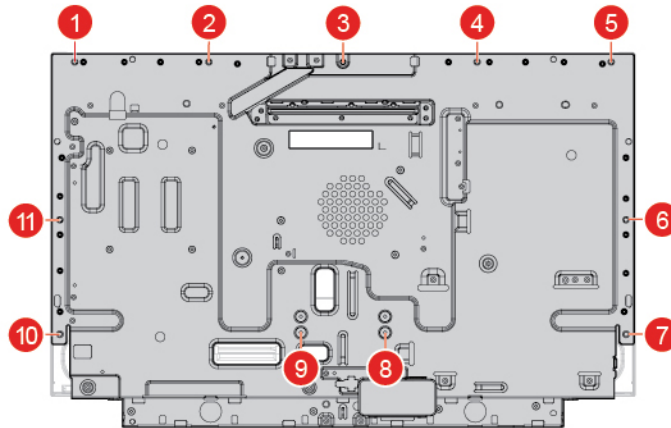

19. Route the new LCD panel cables, and then connect the cables to the system board.
20. Reinstall the removed parts. To complete the replacement, see “Completing the parts replacement” on page 55.

---

## Completing the parts replacement

After completing the installation or replacement for all parts, reinstall the computer cover and reconnect the cables.

To reinstall the computer cover and reconnect the cables to your computer, do the following:

1. Ensure that all components have been reassembled correctly and that no tools or loose screws are left inside your computer.
2. Ensure that the cables are routed correctly before reinstalling the computer cover. Keep cables clear of the hinges and sides of the computer chassis to avoid interference when reinstalling the computer cover.
3. Reinstall the computer cover.

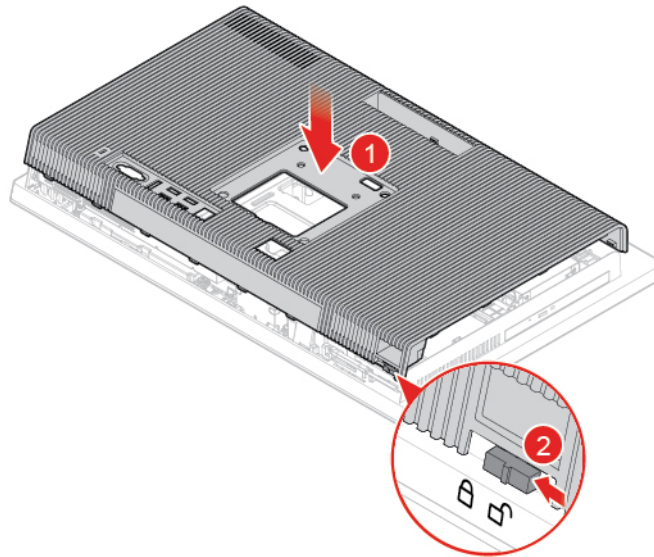

Figure 92. Reinstalling the computer cover

4. Install the computer stand. See “Replacing the computer stand” on page 16.
5. Place the computer in an upright position.
6. If a locking device is available, use it to lock the computer.
7. Reconnect the external cables and power cords to the corresponding connectors on the computer.

---

## Appendix A. Notices

Lenovo may not offer the products, services, or features discussed in this document in all countries. Consult your local Lenovo representative for information on the products and services currently available in your area. Any reference to a Lenovo product, program, or service is not intended to state or imply that only that Lenovo product, program, or service may be used. Any functionally equivalent product, program, or service that does not infringe any Lenovo intellectual property right may be used instead. However, it is the user's responsibility to evaluate and verify the operation of any other product, program, or service.

Lenovo may have patents or pending patent applications covering subject matter described in this document. The furnishing of this document does not give you any license to these patents. You can send license inquiries, in writing, to:

*Lenovo (United States), Inc.  
1009 Think Place - Building One  
Morrisville, NC 27560  
U.S.A.  
Attention: Lenovo Director of Licensing*

LENOVO PROVIDES THIS PUBLICATION "AS IS" WITHOUT WARRANTY OF ANY KIND, EITHER EXPRESS OR IMPLIED, INCLUDING, BUT NOT LIMITED TO, THE IMPLIED WARRANTIES OF NON-INFRINGEMENT, MERCHANTABILITY OR FITNESS FOR A PARTICULAR PURPOSE. Some jurisdictions do not allow disclaimer of express or implied warranties in certain transactions, therefore, this statement may not apply to you.

This information could include technical inaccuracies or typographical errors. Changes are periodically made to the information herein; these changes will be incorporated in new editions of the publication. Lenovo may make improvements and/or changes in the products and/or the programs described in this publication at any time without notice.

The products described in this document are not intended for use in implantation or other life support applications where malfunction may result in injury or death to persons. The information contained in this document does not affect or change Lenovo product specifications or warranties. Nothing in this document shall operate as an express or implied license or indemnity under the intellectual property rights of Lenovo or third parties. All information contained in this document was obtained in specific environments and is presented as an illustration. The result obtained in other operating environments may vary.

Lenovo may use or distribute any of the information you supply in any way it believes appropriate without incurring any obligation to you.

Any references in this publication to non-Lenovo Web sites are provided for convenience only and do not in any manner serve as an endorsement of those Web sites. The materials at those Web sites are not part of the materials for this Lenovo product, and use of those Web sites is at your own risk.

Any performance data contained herein was determined in a controlled environment. Therefore, the result obtained in other operating environments may vary significantly. Some measurements may have been made on development-level systems and there is no guarantee that these measurements will be the same on generally available systems. Furthermore, some measurements may have been estimated through extrapolation. Actual results may vary. Users of this document should verify the applicable data for their specific environment.



---

## **Appendix B. Trademarks**

LENOVO, LENOVO logo, and THINKCENTRE logo are trademarks of Lenovo. DisplayPort is a trademark of the Video Electronics Standards Association. USB-C is a trademark of USB Implementers Forum. All other trademarks are the property of their respective owners. © 2019 Lenovo.







