

GEIST™ SWITCHAIR

AIRFLOW MANAGEMENT DEVICE

Quick Installation Guide



Models:

SA1-01002XLNB

Type:

Rear Air Intake-Front (Port)
Exhaust Switches

CAUTION: Ensure the required airflow for safe operation of equipment is not compromised when installing the Geist SwitchAir.

WARNING: Take precaution to avoid interference with the switch input power cords when installing on a live unit.

1. Installing the adjustable rails

Using customer provided hardware, insert cage nuts into the front two holes as well as the rear extension tab hole of each adjustable rail.

Select a 1U space in the rack and hold one of the rails in position between the front and rear rack uprights. Lengthen or shorten the adjustable rail by adjusting the rear extension tab, loosely fitting the rail between the insides of the rack uprights.

Attach the front of the adjustable rail to the front upright using only the top hole of the 1U space. Leave the bottom front hole open for later use.

Attach the rear rail extension tab to the rear rack upright. Use the center hole of the 1U space for this attachment.

Repeat the procedure for installation of the adjustable rail on the opposite side.

2. Installing the switch

Slide the network switch into the rails. Using customer provided cage nuts and screws, mount the switch to the rear

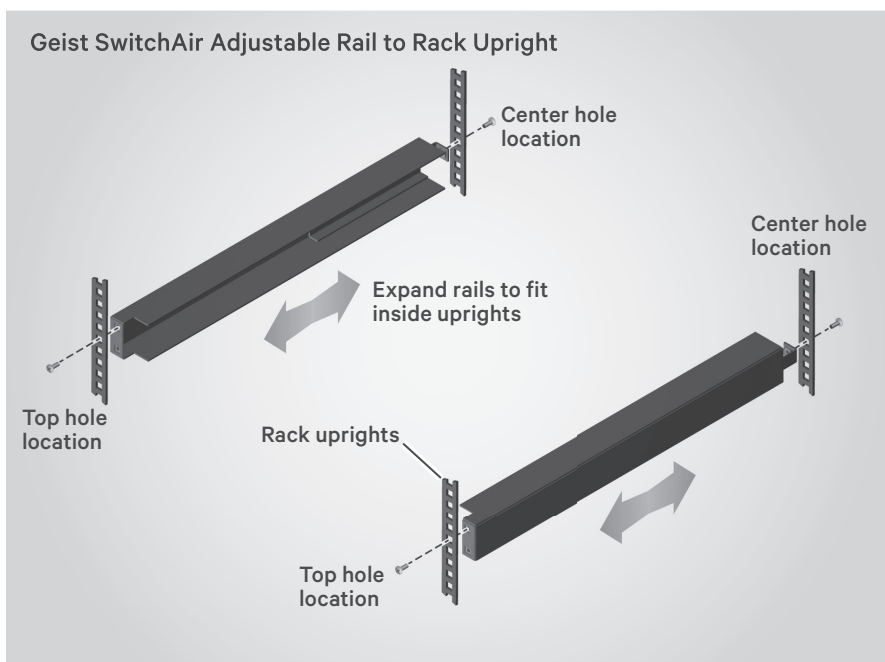
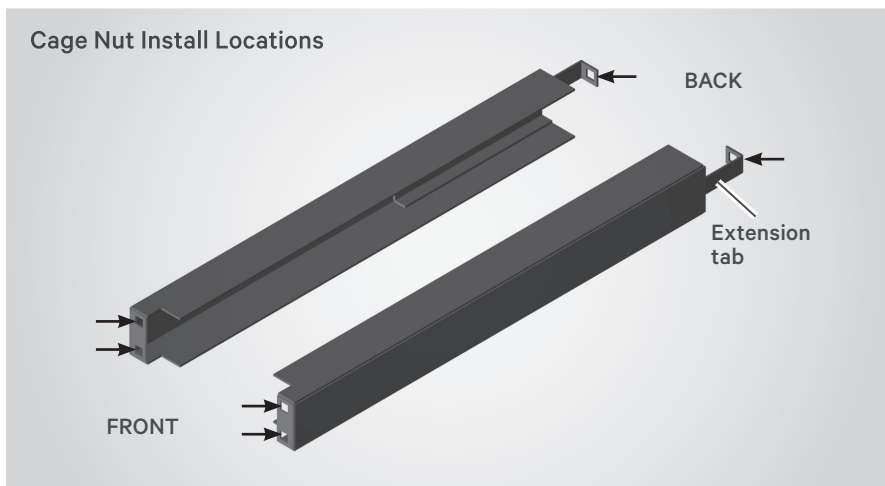

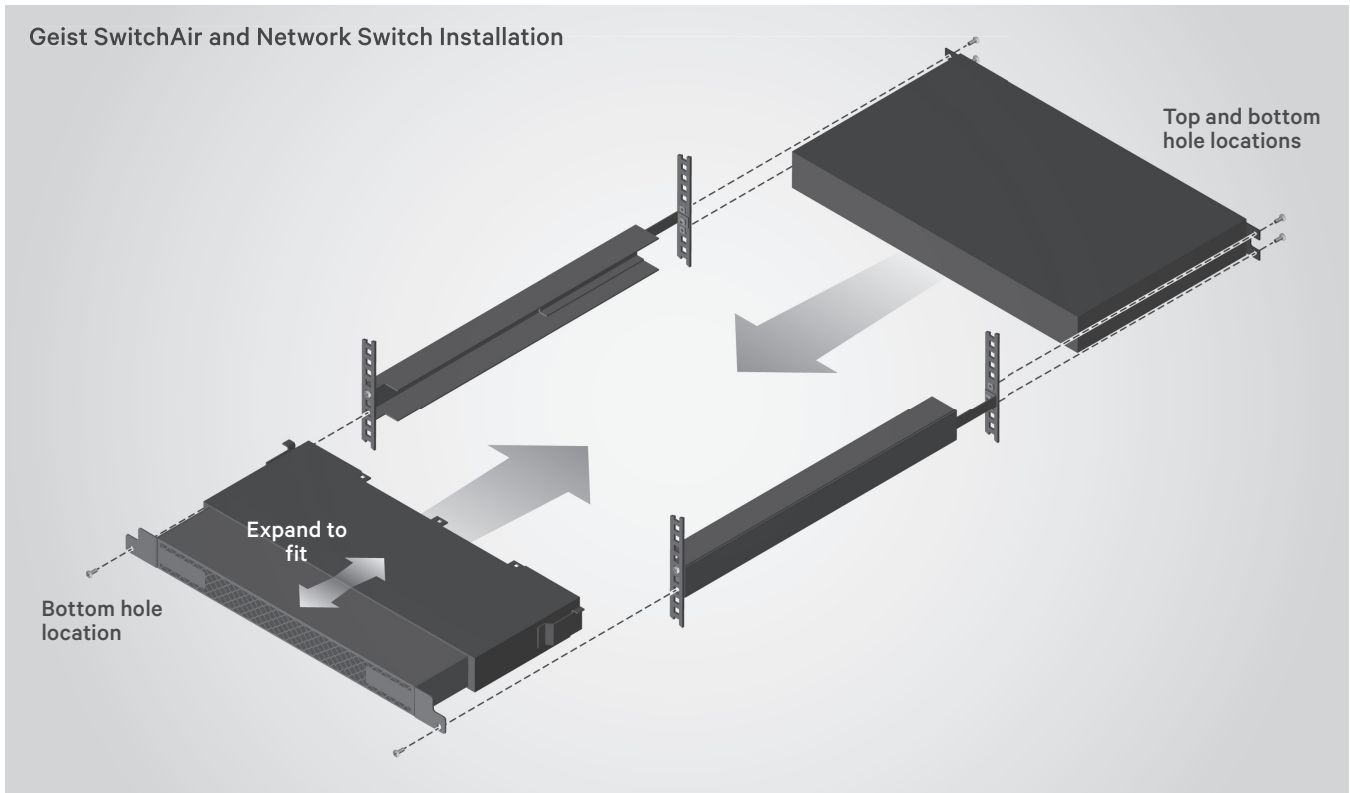

rack uprights using the 1U space's top and bottom holes.

3. Mounting the SwitchAir unit

SwitchAir is not in the fully extended position when shipped from the factory. Pull evenly on the chassis mounting tabs for the desired depth.

Insert SwitchAir into the rails and push unit back until the insert comes in contact with the network switch and the front chassis mounting tabs are flush with the rack front rails. Install the bottom chassis screws on both sides.

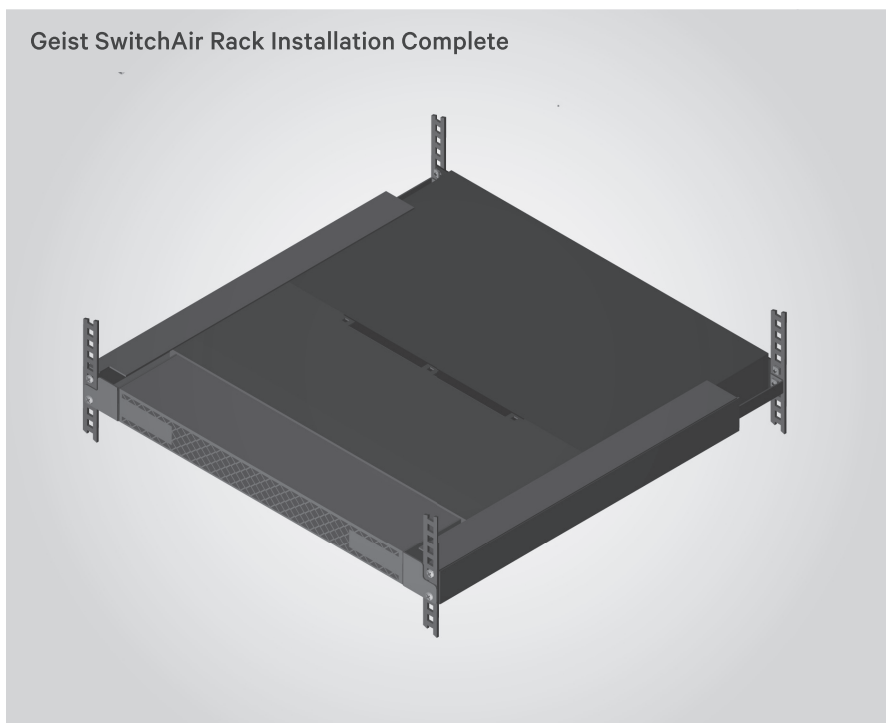

To contact Vertiv Technical Support: visit www.VertivCo.com

© 2019 Vertiv Co. All rights reserved. Vertiv and the Vertiv logo are trademarks or registered trademarks of Vertiv Co. All other names and logos referred to are trade names, trademarks or registered trademarks of their respective owners. While every precaution has been taken to ensure accuracy and completeness herein, Vertiv Co. assumes no responsibility, and disclaims all liability, for damages resulting from use of this information or for any errors or omissions. Specifications are subject to change without notice.

