



Hardware Installation Guide for Cisco NCS 5500 Series Modular Routers

First Published: 2015-12-23

Last Modified: 2022-03-31

Americas Headquarters

Cisco Systems, Inc.
170 West Tasman Drive
San Jose, CA 95134-1706
USA
<http://www.cisco.com>
Tel: 408 526-4000
800 553-NETS (6387)
Fax: 408 527-0883

THE SPECIFICATIONS AND INFORMATION REGARDING THE PRODUCTS IN THIS MANUAL ARE SUBJECT TO CHANGE WITHOUT NOTICE. ALL STATEMENTS, INFORMATION, AND RECOMMENDATIONS IN THIS MANUAL ARE BELIEVED TO BE ACCURATE BUT ARE PRESENTED WITHOUT WARRANTY OF ANY KIND, EXPRESS OR IMPLIED. USERS MUST TAKE FULL RESPONSIBILITY FOR THEIR APPLICATION OF ANY PRODUCTS.

THE SOFTWARE LICENSE AND LIMITED WARRANTY FOR THE ACCOMPANYING PRODUCT ARE SET FORTH IN THE INFORMATION PACKET THAT SHIPPED WITH THE PRODUCT AND ARE INCORPORATED HEREIN BY THIS REFERENCE. IF YOU ARE UNABLE TO LOCATE THE SOFTWARE LICENSE OR LIMITED WARRANTY, CONTACT YOUR CISCO REPRESENTATIVE FOR A COPY.

The Cisco implementation of TCP header compression is an adaptation of a program developed by the University of California, Berkeley (UCB) as part of UCB's public domain version of the UNIX operating system. All rights reserved. Copyright © 1981, Regents of the University of California.

NOTWITHSTANDING ANY OTHER WARRANTY HEREIN, ALL DOCUMENT FILES AND SOFTWARE OF THESE SUPPLIERS ARE PROVIDED "AS IS" WITH ALL FAULTS. CISCO AND THE ABOVE-NAMED SUPPLIERS DISCLAIM ALL WARRANTIES, EXPRESSED OR IMPLIED, INCLUDING, WITHOUT LIMITATION, THOSE OF MERCHANTABILITY, FITNESS FOR A PARTICULAR PURPOSE AND NON-INFRINGEMENT OR ARISING FROM A COURSE OF DEALING, USAGE, OR TRADE PRACTICE.

IN NO EVENT SHALL CISCO OR ITS SUPPLIERS BE LIABLE FOR ANY INDIRECT, SPECIAL, CONSEQUENTIAL, OR INCIDENTAL DAMAGES, INCLUDING, WITHOUT LIMITATION, LOST PROFITS OR LOSS OR DAMAGE TO DATA ARISING OUT OF THE USE OR INABILITY TO USE THIS MANUAL, EVEN IF CISCO OR ITS SUPPLIERS HAVE BEEN ADVISED OF THE POSSIBILITY OF SUCH DAMAGES.

Any Internet Protocol (IP) addresses and phone numbers used in this document are not intended to be actual addresses and phone numbers. Any examples, command display output, network topology diagrams, and other figures included in the document are shown for illustrative purposes only. Any use of actual IP addresses or phone numbers in illustrative content is unintentional and coincidental.

All printed copies and duplicate soft copies of this document are considered uncontrolled. See the current online version for the latest version.

Cisco has more than 200 offices worldwide. Addresses and phone numbers are listed on the Cisco website at www.cisco.com/go/offices.

Cisco and the Cisco logo are trademarks or registered trademarks of Cisco and/or its affiliates in the U.S. and other countries. To view a list of Cisco trademarks, go to this URL: <https://www.cisco.com/c/en/us/about/legal/trademarks.html>. Third-party trademarks mentioned are the property of their respective owners. The use of the word partner does not imply a partnership relationship between Cisco and any other company. (1721R)

© 2016–2022 Cisco Systems, Inc. All rights reserved.



CONTENTS

CHAPTER 1

NCS 5500 Series Modular Router Overview	1
Cisco NCS 5500 Series Modular Routers	1
Slot Numbering for Cisco NCS 5500 Series Modular Routers	3
Line Card Overview	9
Modular Port Adapters	20
Route Processor Card Overview	27
Environmental and Physical Specifications	29
Weight, Quantity and Power Consumption	29
Airflow Direction	30
Maximum Power Available to the Router	30
Transceivers, Connectors, and Cables	33
Transceiver and Cable Specifications	33
RJ-45 Connectors	34
Pinouts	34
BITS Port Pinouts	34
Time-of-Day Port Pinouts	35
Management and PTP Ethernet Port Pinouts	35
USB Flash or MEM Port Pinouts	36
Power Supply Power Cord Specifications	36

CHAPTER 2

Prepare for Installation	43
Review Installation Roadmap	43
Review Safety Guidelines	43
Cautions and Regulatory Compliance Statements for NEBS	44
Review Installation Guidelines	45
Review Site Maintenance Guidelines	45

Procure Tools and Equipment 48
 Rack Mount and Accessory Kits 48
 Prepare Your Location 50
 Airflow for Site Planning 51
 Prepare Yourself 52
 Prepare Rack for Chassis Installation 53
 Clearance Requirements 54

CHAPTER 3

Install the Chassis 57

Unpack the Chassis 57
 Install Bottom-Support Rails 58
 Transfer Chassis to a Mechanical Lifting Device 60
 (Optional) Install the Rear Chassis Brackets 62
 Mount Chassis Into the Rack 65
 (Optional) Install Air Filter, Cable Management Bracket, or Door Kit on a Chassis 71
 Attach Front Door to NCS 5504 and NCS 5508 Chassis 86
 Attach Front Door to NCS 5516 Chassis 88
 Replace Chassis Door Foam Air Filters on the NCS 5504 88
 Replace Chassis Door Foam Air Filters on the NCS 5508 89
 Replace Chassis Door Foam Air Filters on the NCS 5516 90
 Ground the Front ID Door 92
 Locate and Ground the Chassis 96
 Connect AC Power Supply to AC Power Source 99
 Connect 3kW DC Power Supply to DC Power Source 99
 Connect 4.4kW DC Power Supply to DC Power Source 101
 Connect HVAC/HVDC Power Supply to Power Source 104

CHAPTER 4

Connect Router to the Network 109

Port Connection Guidelines 109
 Connecting a Console to the Router 110
 Connect the Management Interface 111
 Installing and Removing Modular Port Adapters 112
 Handling Modular Port Adapters 112
 Online Insertion and Removal 113

Modular Port Adapter Installation and Removal	114
Install and Remove Transceiver Modules	115
Install and Remove SFP Modules	115
Bale Clasp SFP or SFP+ Module	116
Install a Bale Clasp SFP or SFP+ Module	116
Remove a Bale Clasp SFP or SFP+ Module	117
Install and Remove QSFP Transceiver Modules	119
Required Tools and Equipment	119
Installing the QSFP Transceiver Module	120
Attach the Optical Network Cable	121
Removing the QSFP Transceiver Module	122
Installing and Removing CFP2 Modules	123
Installing a CFP2 Module	123
Removing a CFP2 Module	124
Connect Interface Ports	124
Connect a Fiber-Optic Port to the Network	124
Disconnect Optical Ports from the Network	125
Maintain Transceivers and Optical Cables	125
Set Fabric Bandwidth Threshold	125

CHAPTER 5
Create Initial Configuration 127

Create the Initial Router Configuration	127
Verify Chassis Installation	129

CHAPTER 6
Replace Chassis Components 131

Replace a Route Processor Card	131
Replace a System Controller Module	135
Installing and Removing a Blank Line Card	137
Installing a Blank Line Card	137
Removing a Blank Line Card	138
Replace a Line Card	140
Installing and Removing Modular Port Adapters	142
Handling Modular Port Adapters	143
Online Insertion and Removal	143

Modular Port Adapter Installation and Removal	144
Replace a Fan Tray	145
Remove Fan Tray	146
Install Fan Tray	147
Replace Fabric Card	149
Removing a Fabric Card	150
Restrictions for using XR plane hw-module configuration	153
Install a Fabric Card	154
Replace Power Supplies	157
Replace AC Power Supply	157
Replace DC Power Supply	160
Replace HVAC/HCDC Power Supply	163

APPENDIX A

LEDs	167
Chassis LEDs	167
System Controller LEDs	168
Route Processor Card LEDs	170
Fan Tray LEDs	172
Fabric Card LEDs	173
Line Card LEDs	174
MPA LEDs	175
Power Supply LEDs	176
Port Status LEDs	178



CHAPTER 1

NCS 5500 Series Modular Router Overview

- [Cisco NCS 5500 Series Modular Routers, on page 1](#)
- [Slot Numbering for Cisco NCS 5500 Series Modular Routers, on page 3](#)
- [Line Card Overview, on page 9](#)
- [Modular Port Adapters, on page 20](#)
- [Route Processor Card Overview, on page 27](#)
- [Environmental and Physical Specifications, on page 29](#)
- [Weight, Quantity and Power Consumption, on page 29](#)
- [Airflow Direction, on page 30](#)
- [Maximum Power Available to the Router, on page 30](#)
- [Transceivers, Connectors, and Cables, on page 33](#)
- [Pinouts, on page 34](#)
- [Power Supply Power Cord Specifications, on page 36](#)

Cisco NCS 5500 Series Modular Routers

The following table lists the various components and its quantity as supported on Cisco NCS 5500 series modular routers.

Component	NCS 5504	NCS 5508	NCS 5516
Line cards – see Line Card Overview, on page 9	4	8	16
Route Processors	1 or 2 – NC55-RP or NC55-RP-E, or NC55-RP2-E		
System Controllers	1 or 2 – NC55-SC		

Component	NCS 5504	NCS 5508	NCS 5516
Fabric Cards	3 to 6 NC55-5504-FC Caution Use only with NC55-5504-FAN.	3 to 6 NC55-5508-FC Caution Use only with NC55-5508-FAN.	3 to 6 NC55-5516-FC Caution Use only with NC55-5516-FAN.
	3 to 6 NC55-5504-FC2 Caution Use only with NC55-5504-FAN2. Minimum requirements for the Cisco NCS 5504 chassis to operate with NC55-5504-FC2 cards are: <ul style="list-style-type: none"> • At least three NC55-5504-FC2 fabric cards and all three NC55-5504-FAN2 fan trays • NC55-5504-FC2 fabric cards must be inserted in slots FM1, FM3, and FM5 	3 to 6 NC55-5508-FC2 Caution Use only with NC55-5508-FAN2. Note During a system upgrade from Release 7.0.1 or Release 7.0.2 to any future release, the NC55-5508-FC2 card reloads twice. The reboot history can be verified using the show reboot-history card location <i><node-id></i> command, in the System Admin Config mode.	3 to 6 NC55-5516-FC2 Caution Use only with NC55-5516-FAN2.
Fan trays	3 NC55-5504-FAN Caution Use only with NC55-5504-FC.	3 NC55-5508-FAN Caution Use only with NC55-5508-FC.	3 NC55-5516-FAN Caution Use only with NC55-5516-FC.
	3 NC55-5504-FAN2 Caution Use only with NC55-5504-FC2.	3 NC55-5508-FAN2 Caution Use only with NC55-5508-FC2.	3 NC55-5516-FAN2 Caution Use only with NC55-5516-FC2.

Component	NCS 5504	NCS 5508	NCS 5516
Power supplies: <ul style="list-style-type: none"> • NC55-PWR-3KW-AC • NC55-PWR-3KW-DC • NC55-PWR-3KW-2HV (3.15-kW HVAC/HVDC dual-input) • NC55-PWR-4.4KW-DC 	4	8	10



Caution

The system does not support a mix of 1st generation fans and fabric cards (NC55-55xx-FAN/NC55-55xx-FC) and 2nd generation fans and fabric cards (NC55-55xx-FAN2 and NC55-55xx-FC2). Attempting to mix 1st generation and 2nd generation components could result in equipment damage.

Slot Numbering for Cisco NCS 5500 Series Modular Routers

Cisco NCS 5504 Modular Router

In Cisco NCS 5504 modular router chassis, the line card slot number starts from 0 through 3. Slot 0 is located at the top of the chassis and slot 3 at the bottom. The fan tray and fabric cards are located at the rear of the chassis. The fabric cards are installed behind the fan trays. These illustrations show the NCS 5504 modular router slot numbering:

Figure 1: Cisco NCS 5504 Router Slot Numbering - Front View

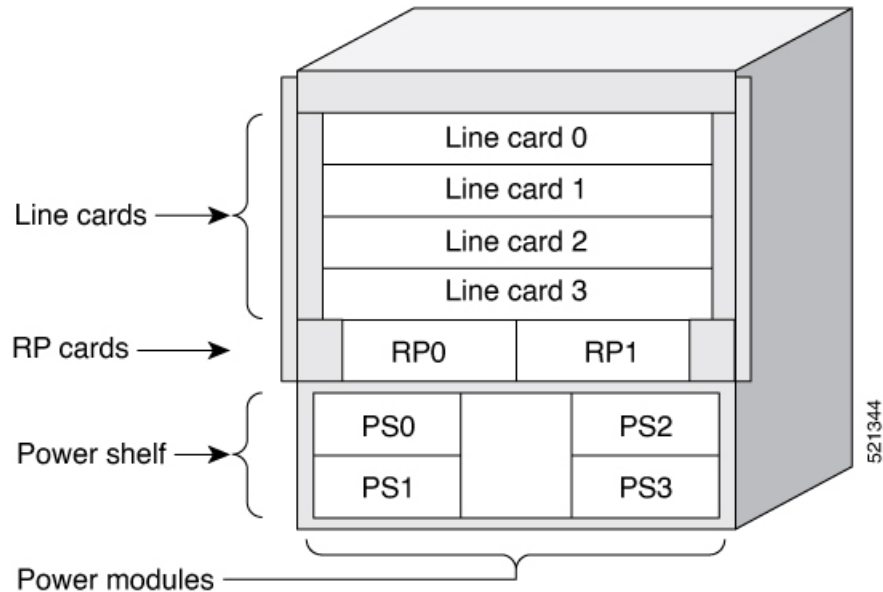
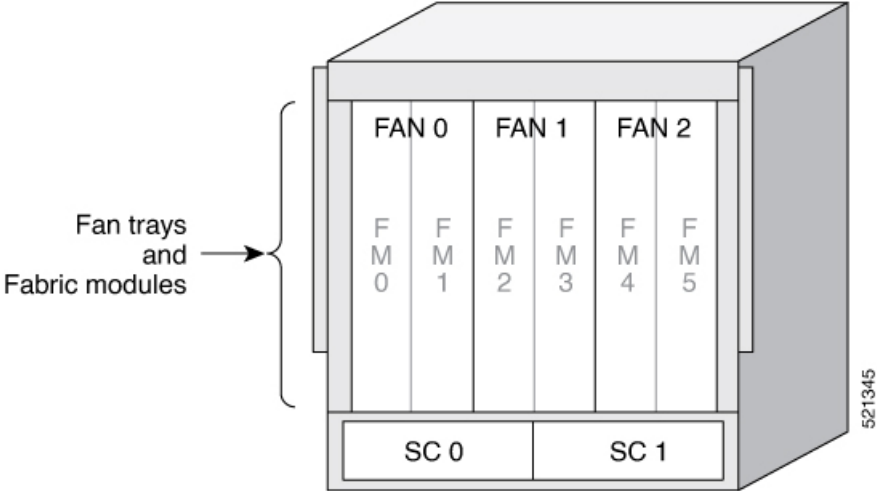

Figure 2: Cisco NCS 5504 Router Slot Numbering - Rear View



Cisco NCS 5508 Modular Router

In Cisco NCS 5508 modular router chassis, the line card slot number starts from 0 through 7. Slot 0 is located at the top of the chassis and slot 7 at the bottom. The fan tray and fabric cards are located at the rear of the chassis. The fabric cards are installed behind the fan trays. These illustrations show the NCS 5508 modular router slot numbering:

Figure 3: Cisco NCS 5508 Router Slot Numbering - Front View

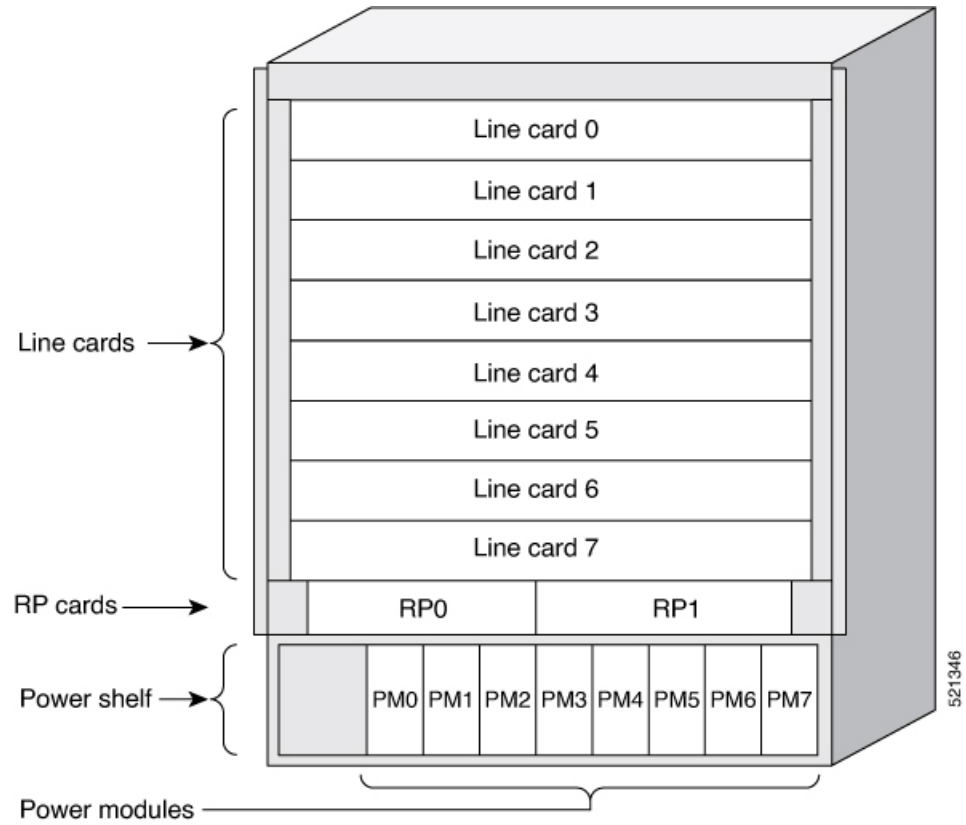
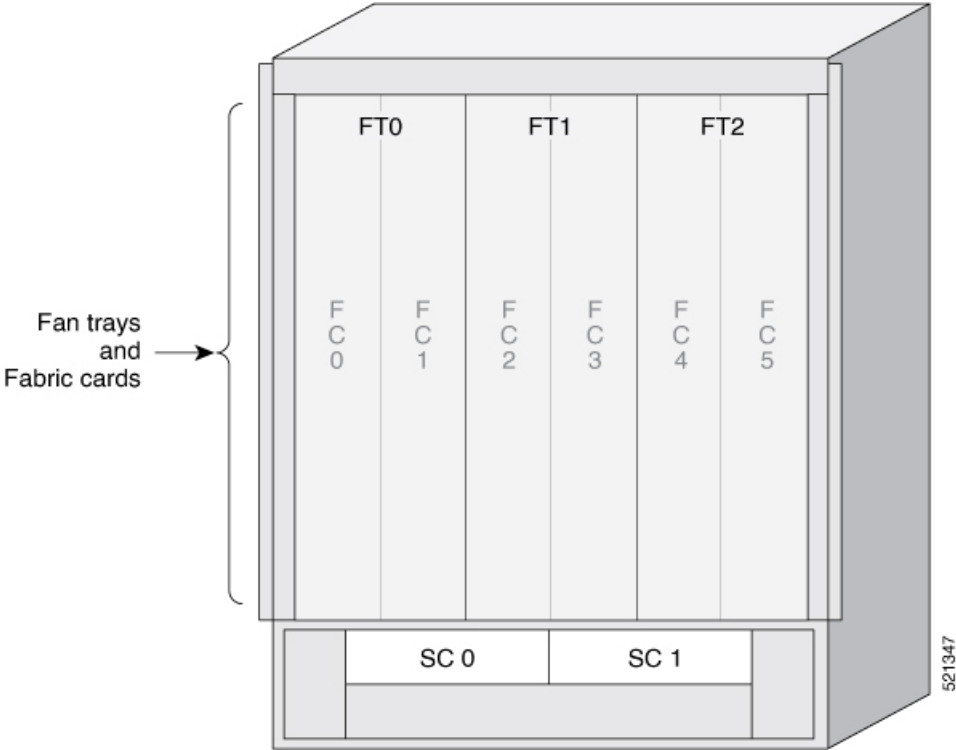

Figure 4: Cisco NCS 5508 Router Slot Numbering - Rear View



Cisco NCS 5516 Modular Router

In Cisco NCS 5516 modular router, the line card slot number starts from 0 through 15. Slot 0 is located at the top of the chassis and slot 15 at the bottom. The fan tray and fabric cards are located at the rear of the chassis. The fabric cards are installed behind the fan trays. These illustrations show the NCS 5516 modular router slot numbering:

Figure 5: Cisco NCS 5516 Router Slot Numbering - Front View

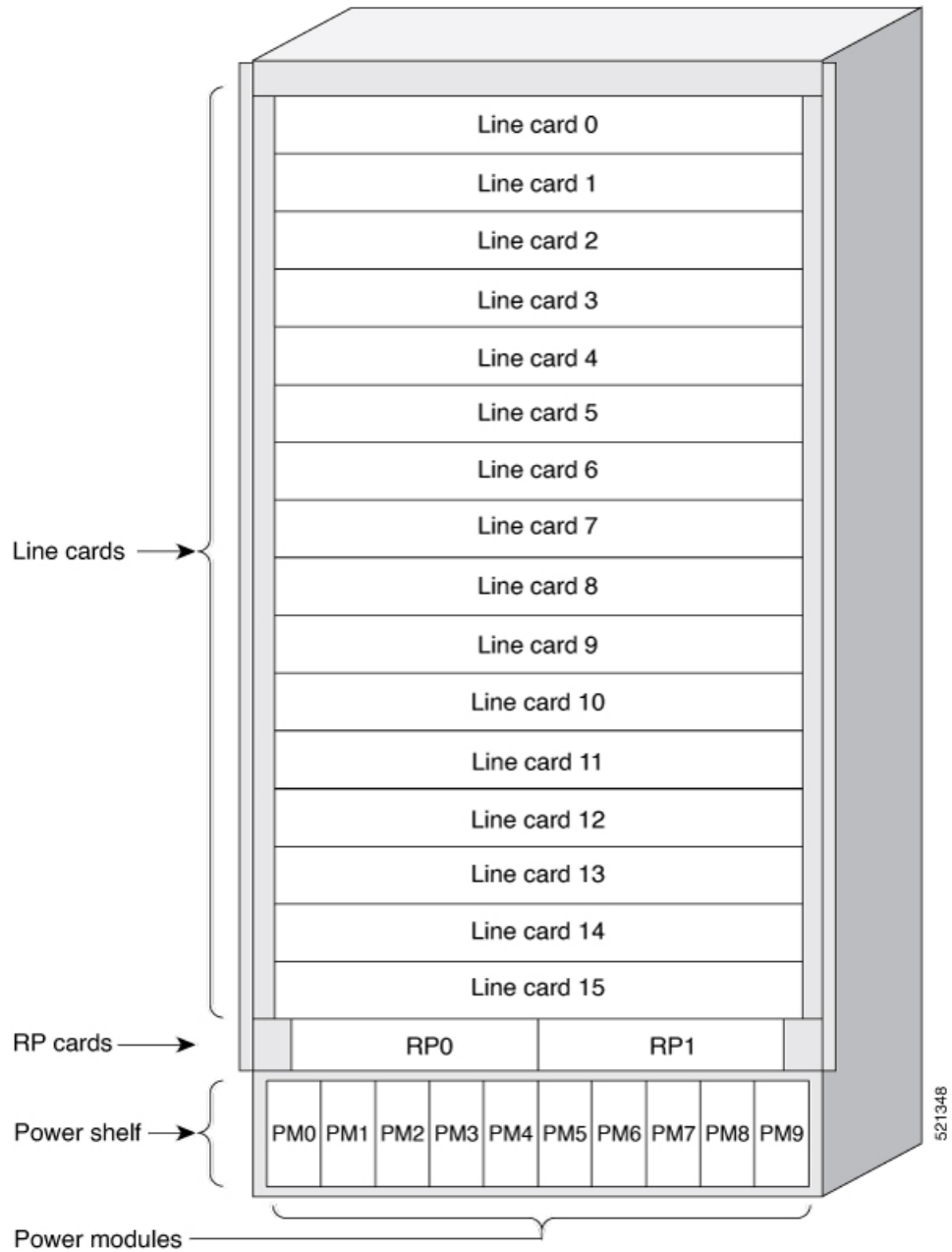
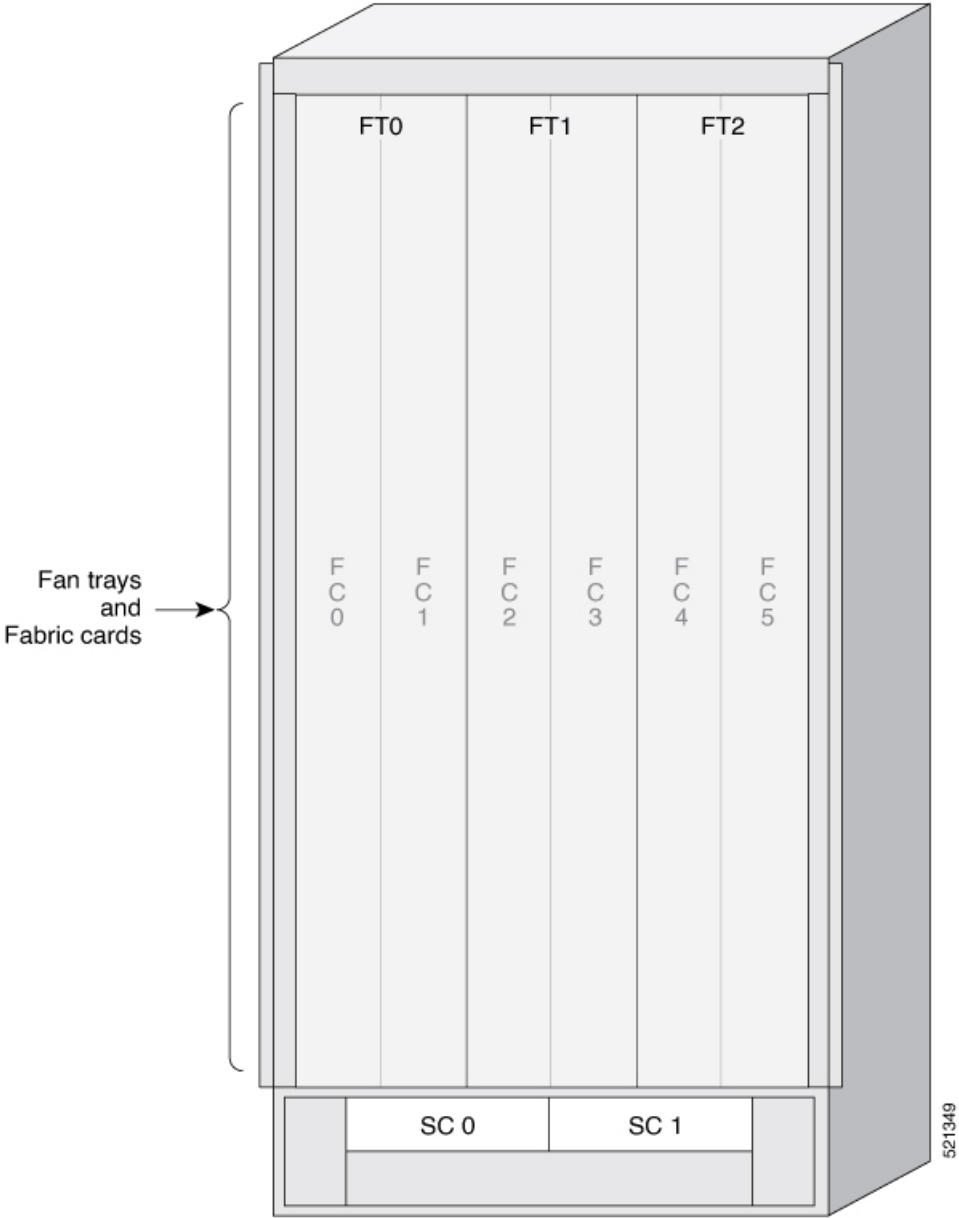

Figure 6: Cisco NCS 5516 Router Slot Numbering - Rear View



Line Card Overview

Table 1: Feature History Table

Hardware	Release Information	Feature Description
NC57-48Q2D-S and NC57-48Q2D-SE-S line cards	Release 7.10.1	<p>The NC57-48Q2D-S is a modular line card that supports front panel bandwidth of 2.4 Tbps through fixed optics ports. The front panel consists of the following port:</p> <ul style="list-style-type: none"> • Two QSFP-DD ports of 400GbE • 16 SFP56 ports of 50GbE • 32 SFP28 ports of 25GbE <p>The NC57-48Q2D-SE-S line card has additional TCAM for supporting expanded Forwarding Information Base (FIB), network access control lists (ACLs), and QoS for scale-enhanced configuration needs.</p> <p>The line card can operate in native mode and compatible mode.</p>

Hardware	Release Information	Feature Description
NC57-MOD-S line card	Release 7.6.1	<p>The NC57-MOD-S is a modular line card that supports front panel ports through a combination of Modular Port Adapters (MPAs) and fixed optics ports. This line card provides 2.8 Tbps bandwidth through:</p> <ul style="list-style-type: none"> • Two MPA slots, each supporting up to 800GbE MPA • Two QSFP-DD ports of 400GbE • Eight SFP56 ports of 50GbE <p>The line card can operate in native mode (all line cards in the chassis are Cisco NCS 5700 line cards) and compatible mode (previous generation Cisco NCS 5500 series line cards are present in the chassis).</p> <p>For the compatibility details of Modular Port Adapters (MPAs) on the line cards, see the Cisco Network Convergence System 5700 Series: 400GbE and 100GbE Line Cards data sheet.</p>
NC57-36H6D-S line card	Release 7.4.1 and Release 7.3.2	<p>This release introduces a 100G optimized NCS 5700 combo line card with 4.8-Tbps throughput. It provides a mix of 100GE, 200GE, and 400GE ports with MACSec support. The line card provides flexible port configuration and can be used as 36x100GE or 24x100GE + 12x200GE, or 24x100GE + 6x400GE ports. For ports 0-23, only even numbered ports support 4x25GE and 4x10GE breakout. The line card can be operated in native mode (all NCS 5700 line cards in the chassis) and compatible mode (mix of NCS 5700 series line cards and previous generation NCS 5500 series line cards).</p>

Hardware	Release Information	Feature Description
NC57-36H-SE line card	Release 7.2.2	This release introduces a 100G optimized NCS 5700 scale line card that provides 36 ports of 100 Gigabit Ethernet with full line rate capacity. All ports support 100GE and 40GE optics. Only even ports support 4x25GE and 4x10GE breakout. The line card works in native and compatibility mode.
NC55-32T16Q4H-A line card	Release 7.2.2	This release introduces a 10G optimized NCS5500 line card that provides 48 ports of 1/10/25 Gigabit Ethernet and 4 ports of 40/100 Gigabit Ethernet. The line card improves port density for low speed interfaces within the family of modular NCS 5500 chassis.



Note We recommend that you run the NC57 line cards in native mode, except when there is a NCS55 line card in the chassis.

The following table describes the line cards supported on the NCS 5500 series modular routers:

Line Card	Ports/Adapters	Transceivers
NC55-24X100-SE	<ul style="list-style-type: none"> • 24 x 100GE–100GE, 40GE, or 4x10GE via breakout cable • QSFP-to-SFP adapter (QSA) with 1GE SFP (GLC-SX-MMD, GLC-LH-SMD) and 10 GE SFP+ (ER, ER-S, ZR, ZR-S, DWDM fixed-wavelengths) 	QSFP28/QSFP+
NC55-36X100G	<ul style="list-style-type: none"> • 36 x 100GE–100GE, 40GE, or 4x10GE via breakout cable • QSFP-to-SFP adapter (QSA) with 1GE SFP (GLC-SX-MMD, GLC-LH-SMD) and 10 GE SFP+ (ER, ER-S, ZR, ZR-S, DWDM fixed-wavelengths) 	
NC55-36X100G-S Supports MACsec and offers 3.6 Tbps Ethernet traffic on the front panel to Fabric that support 5.4 Tbps.	<ul style="list-style-type: none"> • 36 x 100GE–100GE, 40GE, 4x25GE via breakout cable, or 4x10GE via breakout cable 	
NC55-36X100G-A-SE Has external TCAM for supporting expanded Forwarding Information Base (FIB), network access control lists (ACLs), and QoS for scale-enhanced configuration needs.	<ul style="list-style-type: none"> • 36 x 100GE–100GE, 40GE, 4x25GE via breakout cable, or 4x10GE via breakout cable • QSFP-to-SFP adapter (QSA) with 10 GE SFP+ (ER, ER-S, ZR, ZR-S, DWDM fixed-wavelengths) 	
NC55-18H18F	<ul style="list-style-type: none"> • 18 x 100GE–100GE, 40GE, or 4x10GE via breakout • 18 x 40GE–40GE or 4x10GE via breakout 	
NCS55-24H12F-SE	<ul style="list-style-type: none"> • 24 x 100GE–100GE, 40GE, or 4x10GE via breakout • 12 x 40GE–40GE or 4x10GE via breakout • QSFP-to-SFP adapter (QSA) with 1GE SFP (GLC-TE, GLC-SX-MMD, GLC-LH-SMD) and 10 GE SFP+ (ER, ER-S, ZR, ZR-S, DWDM fixed-wavelengths) 	

Line Card	Ports/Adapters	Transceivers
<p>NC55-6X200-DWDM-S</p> <p>Adds DWDM capabilities to the NCS 5500 series modular chassis.</p> <p>Along with the ONS-CFP2-WDM long-haul optics, this line card eliminates the need to connect short-range grey optics to a dedicated optical platform between NCS 5500 series modular chassis. Thus reducing operating expenses and capital costs.</p>	<p>6 x 100GE—Supports 100 Gbps (DWDM QPSK), 150 Gbps (DWDM 8 QAM), or 200 Gbps (DWDM 16 QAM) WDM signals with full line-rate MACsec capability.</p>	<p>Second-generation Coherent Transceiver Pluggable (CTP2) optics modules (in CFP2 form-factor).</p>
<p>NC55-MOD-A-S</p> <p>NC55-MOD-A-SE-S— has external TCAM for supporting expanded Forwarding Information Base (FIB), network access control lists (ACLs), and QoS for scale-enhanced configuration needs.</p>	<ul style="list-style-type: none"> • 12 x 1GE/10GE • 2 x 40GE • 2 modular port adapters (MPAs) See the Modular Port Adapters section for port details. <p>Note QDD-400G-ZR-S and QDD-400G-ZRP-S optical modules are supported on all 400G ports of the MPA(NC57-MPA-2D4H-S).</p>	<p>SFP/SFP+</p> <p>QSFP+</p> <p>QSFP-DD</p>
<p>NC-55-32T16Q4H-A</p>	<ul style="list-style-type: none"> • 4 x 100GE/40GE QSFP ports • 16 x 10GE/25GE SFP ports • 32 x 1GE/10GE SFP ports <p>Restrictions</p> <ul style="list-style-type: none"> • 1G optical modules aren't supported on ports starting from 32 through 47. • Dual rate optics are only supported in higher speed mode. For example, SFP-10/25G-LR-S is only supported in 25G mode. • Breakout operation isn't supported. 	<p>QSFP28 /QSFP+</p> <p>SFP28/SFP+</p> <p>SFP+/SFP</p>

Line Card	Ports/Adapters	Transceivers
<p>NC57-24DD</p> <p>Supported in the NCS 5508 and NCS 5516 chassis with second-generation fabric cards (NC55-5508-FC2/NC55-5516-FC2) and fan trays (NC55-5508-FAN2/NC55-5516-FAN2). Requires Cisco IOS XR 7.0.2 or later.</p> <p>Supported in the NCS 5504 chassis with second-generation fabric cards (NC55-5504-FC2) and fan trays (NC55-5504-FAN2). Requires Cisco IOS XR 7.2.2 or later.</p>	<ul style="list-style-type: none"> • 24 ports x 400GE • 40GE (4x10GE) and 100GE (4x25GE) with QSFP28 optics • 400GE (4x100GE) and 200GE (2x100GE) with QSFPDD optics <p>Note To ensure proper airflow and to minimize potential over temperature conditions, the NC57-24DD line card supports up to twelve QDD-400G-ZR-S/QDD-400G-ZRP-S optical modules only installed in the top ports (0 and even-numbered ports).</p>	<p>QSFP+</p> <p>QSFP28</p> <p>QSFP-DD</p>
<p>NC57-18DD-SE</p> <p>Supported in the NCS 5508 and NCS 5516 chassis with second-generation fabric cards (NC55-5508-FC2/NC55-5516-FC2) and fan trays (NC55-5508-FAN2/NC55-5516-FAN2). Requires Cisco IOS XR 7.0.2 or later.</p> <p>Supported in the NCS 5504 chassis with second-generation fabric cards (NC55-5504-FC2) and fan trays (NC55-5504-FAN2). Requires Cisco IOS XR 7.2.2 or later.</p>	<ul style="list-style-type: none"> • 18 x 400GE (12 ports unused) Or 30 x 200GE – 200GE, 100GE • 40GE (4x10GE) and 100GE (4x25GE) with QSFP28 optics • 400GE (4x100GE) and 200GE (2x100GE) with QSFPDD optics <p>Note Due to power limitations, the NC57-18DD-SE line card supports up to nine QDD-400G-ZR-S optical modules, or a combination of six QDD-400G-ZR-S and QDD-400G-ZRP-S optical modules. Install QDD-400G-ZR-S and QDD-400G-ZRP-S optics only in the top ports (0 and even-numbered ports).</p>	<p>QSFP+</p> <p>QSFP28</p> <p>QSFP-DD</p>
<p>NC57-36H-SE</p>	<ul style="list-style-type: none"> • 36 x 100GE/40GE/10GE ports • All 36 ports support QSFP28/QSFP+ optics. • 6 ports (even-numbered ports 24-35) have additional capability to support QSFP-DD 100G ZR optics. • Breakout supported with 4x25G or 4x10G on the even-numbered ports (top row) with the odd-numbered ports (bottom row) disabled <p>Note NC57-36H-SE doesn't support 400G.</p>	<p>QSFP+</p> <p>QSFP28</p> <p>QSFP-DD</p>

Line Card	Ports/Adapters	Transceivers
<p>NC57-36H6D-S line card is supported in the following chassis with second generation fabric cards and fan trays:</p> <ul style="list-style-type: none"> • Cisco NCS 5504 • Cisco NCS 5508 • Cisco NCS 5516 <p>The second-generation fabric cards are:</p> <ul style="list-style-type: none"> • NC55-5504-FC2 • NC55-5508-FC2 • NC55-5516-FC2 <p>The second-generation fan trays are:</p> <ul style="list-style-type: none"> • NC55-5504-FAN2 • NC55-5508-FAN2 • NC55-5516-FAN2 	<p>Flexible port configuration supports the following options:</p> <ul style="list-style-type: none"> • 36 ports of 100GE/40GE • 24 ports (ports 0-23) of 100GE • 12 ports (ports 24-35) of 200GE, using 2x100GE • 24 ports (ports 0-23) of 100GE and 6 ports (even-numbered ports in 24-34) of 400GE • Ports 0-23 supports 4x10GE or 4x25GE breakout on even-numbered (ports in the top row of the card) only. • Ports 24-35 supports 4x10GE or 4x25GE breakout on all ports. • Ports 24-34 supports 4x100GE breakout on even-numbered ports only. 	<p>QSFP+</p> <p>QSFP28</p> <p>QSFP-DD</p> <p>SFP+</p>
<p>NC57-MOD-S</p>	<ul style="list-style-type: none"> • Two MPA slots • Eight ports of 10GE/25GE/50GE SFP optics • Two ports of 40GE/100GE/400GE QSFP-DD optics 	<p>SFP+</p> <p>SFP28</p> <p>SFP56</p> <p>QSFP+</p> <p>QSPF28</p> <p>QSFP-DD</p>

NC57-18DD-SE Line Card

In NC57-18DD-SE line card, there are eighteen 400GE ports which are the even-numbered ports between Port 0 and Port 29, Port 19, Port 21, and Port 23. The 400GE ports are marked on the front panel with blue indicator (see) [Figure 7: NC57-18DD-SE Line Card, on page 15](#).

In 400GE configuration, the odd-numbered ports (except Port 19, Port 21, and Port 23) marked in orange at the bottom row (see) [Figure 7: NC57-18DD-SE Line Card, on page 15](#) aren't used.

The NC57-18DD-SE supports 200GE optics or 100GE optics in all 30 ports.

Figure 7: NC57-18DD-SE Line Card

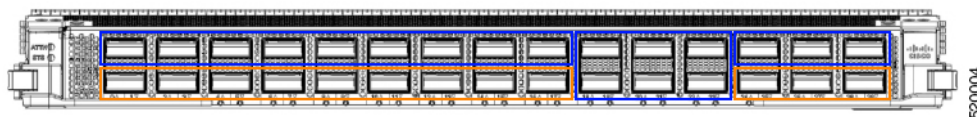

Port 0 to 17 and Port 24 to 29 can only be used in pairs (one top port and its respective bottom port make a pair), with the following restrictions:

- If the top port has 400GE optic, then the bottom ports can't be used.
- If the top port has 200GE, 100GE, or 40GE optic, the respective bottom port in the pair should also be 200GE, 100GE, or 40GE optic.

NC57-36H-SE Line Card

The line card can operate in routers with the previous generation Cisco NCS 5500 series line cards (in compatibility mode) in the same modular chassis and can also operate in a chassis with all Cisco NCS 5700 series line cards (in native mode).



Note NC57-36H-SE line card doesn't support 400G QSFP-DD transceivers.

Supported in the NCS 5504, NCS 5508, and NCS 5516 chassis with second-generation fabric cards (NC55-5504-FC2/NC55-5508-FC2/NC55-5516-FC2) and fan trays (NC55-5504-FAN2/NC55-5508-FAN2/NC55-5516-FAN2). Requires Cisco IOS XR 7.2.2 or later.

For more details, refer to the [data sheet](#).

Even-numbered ports 24 to 35 have additional capability to support QSFP-DD 100G ZR optics and are marked in purple.

If you have already inserted a NC57-36H-SE line card on a router that is running a lower version than Cisco IOS XR Release 7.2.2 and the line card fails to boot, then use the following method to boot the line card:

1. Power off the router.
2. Remove the NC57-36H-SE line card after the router is powered off.
3. Power up the router.
4. Upgrade the router to release 7.2.2 or later.
5. After the software is upgraded, insert the line card.
The line card boots up with release 7.2.2 or later.
6. iPXE boot the line card.

For more information about iPXE boot, see the *System Setup and Software Installation Guide for Cisco NCS 5500 Series Routers*.

NC57-36H6D-S Line Card

The line card can operate in routers with the previous generation Cisco NCS 5500 series line cards (in compatibility mode) in the same modular chassis and can also operate in a chassis with all Cisco NCS 5700 series line cards (in native mode).

Figure 8: Port Numbering on NC57-36H6D-S Line Card

The line card is supported in the Cisco NCS 5504, Cisco NCS 5508 and Cisco NCS 5516 chassis with second-generation fabric cards and fan trays. To support the line card, the chassis must be running Cisco IOS XR 7.3.2, 7.4.1, or later versions.

For more details on features, benefits, and ordering information, see the [data sheet](#).

This figure shows flexible port configuration options:

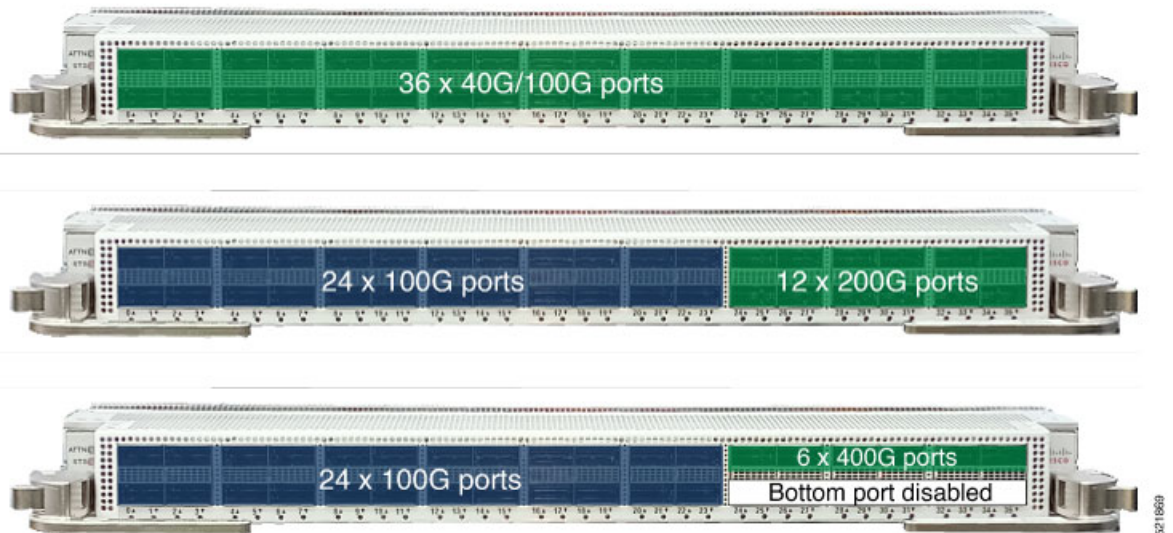
Figure 9: Flexible Port Configuration

A group of four sequential ports form a quad group (ports 0-3, ports 4-7, ports 8-11 and so on). Quad groups in the port range 0-23 have limitations in terms of breakout support; that is, a combination of 40GE and 4x10GE optics or a combination of 4x10GE and 4x25GE is not supported within a quad group.



Note In ports 24-35, the combination of 2x100G and 40G in the same quad group isn't supported.



Note The combination of 4x25G and QSFP+ (40G/4x10G) optics in a given quad group isn't supported.

A group of two ports form a quad group on ports 24-25, 26-27, and so on. Each quad group consists of two ports each on ports 24-35. There is no restriction on combination of 4x10GE or 4x25GE breakout support on the ports 24-35.

To configure 4x25, or 4x10 breakout on ports 0-23, use the **hw-mod port-range** command. However, the 4x100 breakout isn't supported.

On ports 24-35:

- To configure 4x25, or 4x10 breakout, use the **controller optics** command.
- To configure 4x100 breakout, use the **hw-mod port-range** command.

NC57-MOD-S Line Card

The NC57-MOD-S line card operates in routers with the previous generation Cisco NCS 5500 series line cards (in compatibility mode) in the same router. It also operates in a router with all line cards that are Cisco NCS 5700 series line cards in native mode.

The line card supports two MPA slots marked in orange, eight 50 GE SFP56 optics ports marked in blue and two 400 GE QSFP-DD optics ports marked in green (See [NC57-MOD-S line card](#)).

Figure 10: NC57-MOD-S Line Card

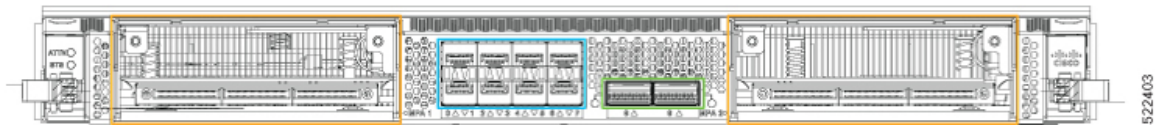

Two QSFP-DD ports support 4x100G, or 4x25G, or 4x10G and 2x100G breakout modes.

This line card is supported in the NCS 5504, NCS 5508, and NCS 5516 chassis with second-generation fabric cards (NC55-5504-FC2/NC55-5508-FC2/NC55-5516-FC2) and fan trays (NC55-5504-FAN2/NC55-5508-FAN2/NC55-5516-FAN2). To support the line card, the chassis must run Cisco IOS XR Release 7.6.1.



Note All fixed ports (eight SFP56 ports and two QSFP-DD ports) of the NC57-MOD-S line card support MACsec.

For more details on features, benefits, and ordering information, see the [Cisco Network Convergence System 5700 Series: 400GE and 100GE Line Cards data sheet](#).

NC57-48Q2D-S and NC57-48Q2D-SE-S Line Card

The NC57-48Q2D-S and NC57-48Q2D-SE-S line cards operate in a router with all line cards that are Cisco NCS 5700 series line cards in native mode. Additionally, they can also operate in routers with the previous generation Cisco NCS 5500 series line cards (in compatibility mode) in the same router.

The NC57-48Q2D-SE-S line card includes additional TCAM to support expanded Forwarding Information Base (FIB), network access control lists (ACLs), and QoS for scale-enhanced configuration requirements.

The line cards support two QSFP-DD ports of 400GbE speed marked in green, 16 SFP56 ports of 50GbE speed marked in blue, and 32 SFP28 ports of 25GbE speed marked in orange (See [NC57-48Q2D-S line card](#)).

Figure 11: NC57-48Q2D-S Line Card

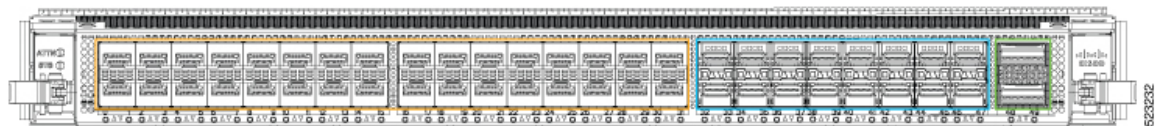

Table 2: Port description

Port Number	Port Type
0 to 31	SFP28
32 to 47	SFP56
48 and 49	QSFPDD

The following optics speeds and breakout configurations are supported by the fixed optic ports:

Optics	SFP28	SFP56	QSFPDD
1GbE	Yes	Yes	No
10GbE	Yes	Yes	No
25GbE	Yes	Yes	No
40GbE	No	No	Yes
50GbE	No	Yes	No
100GbE	No	No	Yes
200GbE	No	No	Yes
400GbE	No	No	Yes
4x10GbE	No	No	Yes
4x25GbE	No	No	Yes
4x100GbE	No	No	Yes
400G ZR	No	No	Only top port-48
400G ZRP	No	No	Only top port-48

This line card is supported in the NCS 5504, NCS 5508, and NCS 5516 router with second-generation fabric cards (NC55-5504-FC2/NC55-5508-FC2/NC55-5516-FC2) and fan trays (NC55-5504-FAN2/NC55-5508-FAN2/NC55-5516-FAN2). To support the line card, the router must run Cisco IOS XR Release 7.10.1.



Note The NC57-48Q2D-S and NC57-48Q2D-SE-S line cards fully support MACsec and PTP-Class-C timing on all fixed ports. The PTP Class-C timing is exclusively supported in compatible mode. However, please note the following limitations when operating 1GbE optics:

- PTP Class-C timing cannot be achieved when MACsec or Auto-negotiation is enabled.
- For IOS XR software release 7.10.1, ports 32 to 47 do not support 1GbE optics.



Note The 400G ZR/ZRP is exclusively compatible with Port 48 and is not supported on Port 49.

For more details on features, benefits, and ordering information, see the [Cisco Network Convergence System 5700 Series: 400GE and 100GE Line Cards data sheet](#).

Modular Port Adapters

The modular port adapters (MPAs) are supported in the NC57-MOD-S, NC55-MOD-A-S and NC55-MOD-A-SE-S line card. Each MPA has a STATUS and ATTN (attention) LED, and each port on the MPA has an adjacent A/L (Active/Link) LED.

To determine which transceivers and cables are supported by these MPAs, see [Cisco Transceiver Modules Compatibility Information](#).



Note Before replacing an MPA card remove the port-range configurations that are applied on that MPA. If these configurations are not removed, interfaces in the new MPA card are not available.

4-Port 40GE/100GE MPA with QSFP+/QSFP28

The 4-port 40GE/100GE MPA (NC55-MPA-4H-S/NC55-MPA-4H-HD-S/NC55-MPA-4H-HX-S) provides 4 ports for 4x25GE (via cable breakout), QSFP+ (40Gbps) or QSFP28 (100Gbps) transceivers.



Note The temperature-hardened NC55-MPA-4H-HD-S MPA operates within industrial temperature range when installed in the temperature-hardened routers.



Note The temperature-hardened conformal-coated NC55-MPA-4H-HX-S MPA operates within industrial temperature range when installed in the temperature-hardened routers.

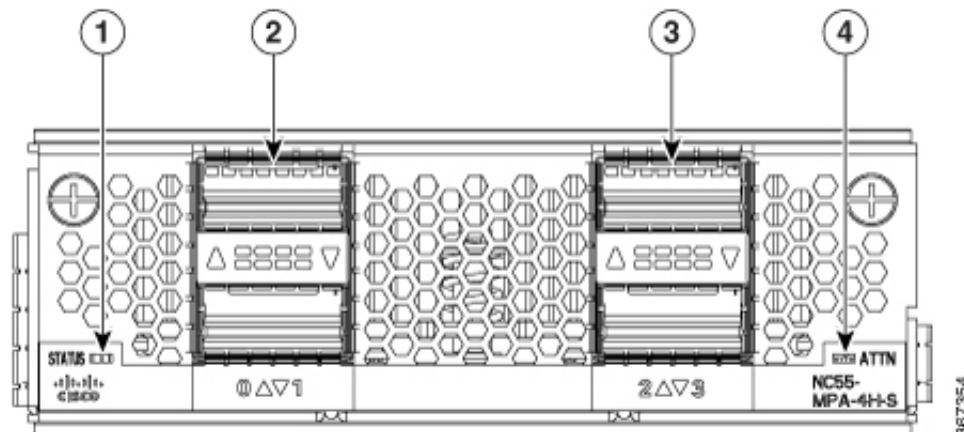

1	STATUS LED	3	QSFP port and Active/Link LED
2	QSFP port and Active/Link LED	4	ATTN LED

2-Port 100GE/200GE with CFP2-DCO

The 2-port 100GE/200GE MPA (NC55-MPA-2TH-S/NC55-MPA-2TH-HX-S) provides 2 ports for CFP2-DCO transceivers.



Note The temperature-hardened conformal-coated NC55-MPA-2TH-HX-S MPA operates within industrial temperature range when installed in the temperature-hardened routers.

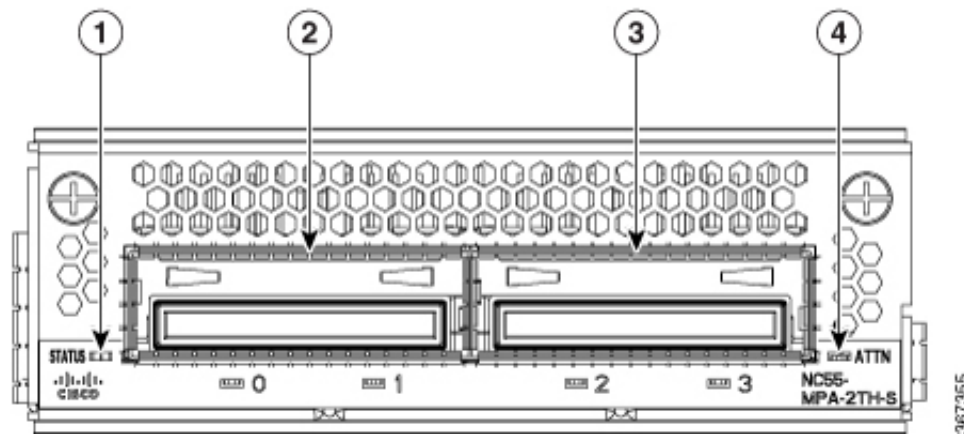

1	STATUS LED	3	CFP2-DCO port and Active/Link LED
2	CFP2-DCO port and Active/Link LED	4	ATTN LED

1-port 100GE/200GE with CFP2-DCO + 2-Port 40GE or 100GE with QSFP+/QSFP28

The 1-port 100GE/200GE + 2-Port 40GE/100GE combination MPA (NC55-MPA-1TH2H-S) provides 1 port for CFP2-DCO transceivers and 2 ports for 4x25GE (via cable breakout), QSFP+ (40Gbps) or QSFP28 (100Gbps) transceivers.

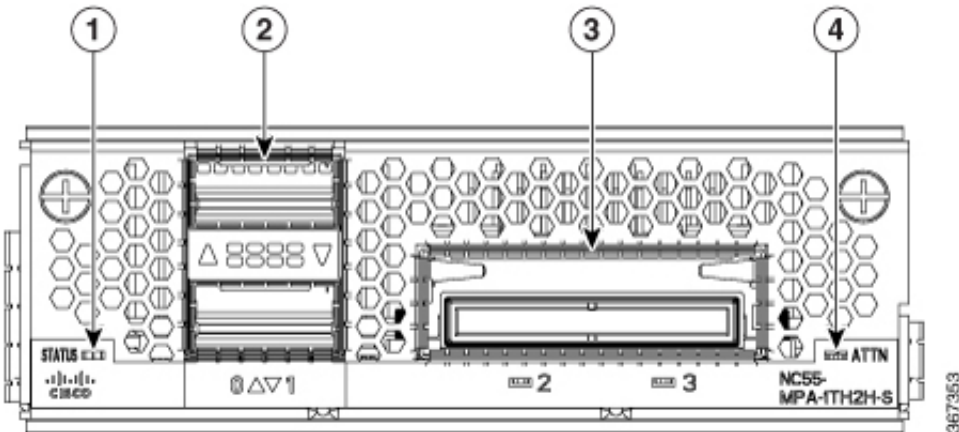

1	STATUS LED	3	CFP2-DCO port and Active/Link LED
2	QSFP port and Active/Link LED	4	ATTN LED

12-Port 10GE with SFP+

The 12-port 10GE MPA (NC55-MPA-12T-S) provides 12 ports for SFP+ transceivers.

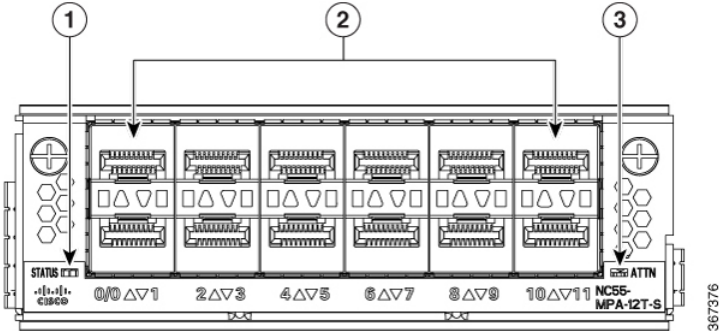

1	STATUS LED	3	ATTN LED
2	SFP+ ports and LEDs		

4-Port 800GE MPA with QSFP28/QSFP-DD

Table 3: Feature History Table

Hardware	Release Information	Description
NC57-MPA-2D4H-S modular port adapter	Release 7.4.1	This release introduces a 4-port 800GE modular port adapter (NC57-MPA-2D4H-S) that supports QSFP28 and QSFP-DD optical transceivers. This MPA is supported in the NCS-55A2-MOD and NCS-57C3-MOD routers. This is the first modular port adapter to support the QSFP-DD optical transceiver.
NC57-MPA-2D4H-S Modular Port Adapter Support on NC55-MOD-A-SE-S Line Card	Release 7.9.1	The 4-port 800GE modular port adapter (NC57-MPA-2D4H-S) is now supported on NC55-MOD-A-SE-S line card.

The NC57-MPA-2D4H-S modular port adapter supports QSFP28 and QSFP-DD optical transceivers in the following configurations:

- All 4 ports support QSFP28-100GE transceivers.
- Ports 0 and 2 (even-numbered ports) support two QDD-2x100GE transceivers at the same time. This configuration is supported in both the MPA slots of the NCS-55A2-MOD-HD-S, NC55-55A2-MOD-SE-S, NCS-55A2-MOD-S, or NCS-55A2-MOD-HX-S chassis.



Note When QDD-2x100GE transceivers are installed in ports 0 and 2, ports 1 and 3 (odd-numbered ports) cannot be used.

- Only one QDD-400GE transceiver is supported through port 0 in both the MPA slots of the NCS-55A2-MOD-HD-S, NC55-55A2-MOD-SE-S, NCS-55A2-MOD-S, or NCS-55A2-MOD-HX-S chassis.

The NC57-MPA-2D4H-S modular port adapter supports the following configurations of optical transceivers while operating on NC55-MOD-A-SE-S and NC57-MOD-S line cards.

Transceiver	MPA slot 1	MPA slot 2
	<ul style="list-style-type: none"> • Max bandwidth on NC55-MOD-A-SE-S line card = 400GE • Max bandwidth on NC57-MOD-S line card = 800GE 	<ul style="list-style-type: none"> • Max bandwidth on NC55-MOD-A-SE-S line card = 400GE • Max bandwidth on NC57-MOD-S line card = 800GE
QSFP28-100GE	All ports	All ports

Transceiver	MPA slot 1	MPA slot 2
QDD-2x100GE	<ul style="list-style-type: none"> On NC55-MOD-A-SE-S line card - Ports 0 and 2 <p>Note When QDD-2x100GE transceivers are installed in ports 0 and 2, then ports 1 and 3 cannot be used.</p> <ul style="list-style-type: none"> On NC57-MOD-S line card - All ports 	<ul style="list-style-type: none"> On NC55-MOD-A-SE-S line card - Ports 0 and 2 <p>Note When QDD-2x100GE transceivers are installed in ports 0 and 2, then ports 1 and 3 cannot be used.</p> <ul style="list-style-type: none"> On NC57-MOD-S line card - All ports
QDD-3x100GE	<ul style="list-style-type: none"> On NC55-MOD-A-SE-S line card - Port 0 <p>Note When QDD-3x100GE transceivers are installed in port 0, then ports 1, 2 and 3 cannot be used.</p> <ul style="list-style-type: none"> On NC57-MOD-S line card - Ports 0 and 2 <p>Note When QDD-3x100GE transceivers are installed in ports 0 and 2, then ports 1 and 3 cannot be used.</p>	<ul style="list-style-type: none"> On NC55-MOD-A-SE-S line card - Port 0 <p>Note When QDD-3x100GE transceivers are installed in port 0, then ports 1, 2 and 3 cannot be used.</p> <ul style="list-style-type: none"> On NC57-MOD-S line card - Ports 0 and 2 <p>Note When QDD-3x100GE transceivers are installed in ports 0 and 2, then ports 1 and 3 cannot be used.</p>
QDD-400GE	<ul style="list-style-type: none"> On NC55-MOD-A-SE-S line card - Not supported On NC57-MOD-S line card - Ports 0 and 2 <p>Note When QDD-400GE transceivers are installed in ports 0 and 2, then ports 1 and 3 cannot be used.</p>	<ul style="list-style-type: none"> On NC55-MOD-A-SE-S line card - Not supported On NC57-MOD-S line card - Ports 0 and 2 <p>Note When QDD-400GE transceivers are installed in ports 0 and 2, then ports 1 and 3 cannot be used.</p>
QDD-4x100GE	<ul style="list-style-type: none"> On NC55-MOD-A-SE-S line card - Port 0 <p>Note When QDD-4x100GE transceivers are installed in port 0, then ports 1, 2 and 3 cannot be used.</p> <ul style="list-style-type: none"> On NC57-MOD-S line card - Ports 0 and 2 <p>Note When QDD-4x100GE transceivers are installed in ports 0 and 2, then ports 1 and 3 cannot be used.</p>	<ul style="list-style-type: none"> On NC55-MOD-A-SE-S line card - Port 0 <p>Note When QDD-4x100GE transceivers are installed in port 0, then ports 1, 2 and 3 cannot be used.</p> <ul style="list-style-type: none"> On NC57-MOD-S line card - Ports 0 and 2 <p>Note When QDD-4x100GE transceivers are installed in ports 0 and 2, then ports 1 and 3 cannot be used.</p>

Figure 12: NCS57-MPA-2D4H-S Modular Port Adapter (MPA)

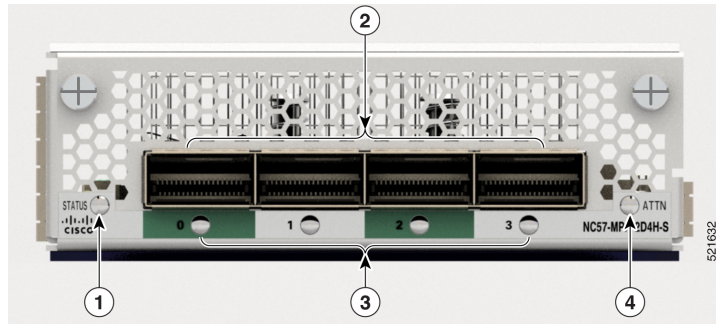

1	STATUS LED	3	Active/Link LED
2	QSFP28/QSFP-DD port and LED	4	ATTN LED

12-Port 10GE/25GE/50GE MPA with SFP+/SFP28/SFP56

Table 4: Feature History Table

Hardware	Release Information	Feature Description
NCS57-MPA-12L-S modular port adapter	Release 7.6.1	<p>A 12-port 600GE modular port adapter that supports SFP+, SFP28, and SFP56 optical transceivers, the NCS57-MPA-12L-S operates in 10GE, 25GE, and 50GE modes.</p> <p>The following command is modified to add support for the 50GE mode for even-numbered ports (port 4, port 6, port 8, and port 10):</p> <ul style="list-style-type: none"> • hw-module port-range <p>For more information, see the Cisco Network Convergence System 5700 Series: Modular Port Adapters Data Sheet.</p>

The NCS57-MPA-12L-S modular port adapter supports SFP+, SFP28 and SFP56 optical transceivers in these configurations:

Table 5: Supported SFP optical transceiver configurations

Port	MPA in NC55-MOD-A-S/NC55-MOD-A-SE-S	MPA in NC57-MOD-S
	Maximum bandwidth per MPA = 400GE	Maximum bandwidth per MPA = 600GE

0 and 1	<ul style="list-style-type: none"> • 10G using hw-module quad command • 25G • 50G • Combination of 25G and 50G <p>Note Combination of 10G with 25G or 50G is not supported.</p>	<ul style="list-style-type: none"> • 10G • 25G • 50G • Combination of 10G and 25G • Combination of 25G and 50G <p>Note Combination of 10G and 50G or 10G, 25G and 50G is not supported.</p>
2 and 3		
4, 5, 6 and 7	<ul style="list-style-type: none"> • 10G using hw-module quad command • 25G • Combination of 25G and 50G <p>Note 50G can be enabled on even-numbered ports using hw-module port-range and the subsequent odd port will be disabled.</p> <p>Note Combination of 10G with 25G or 50G is not supported.</p>	
8, 9, 10 and 11		

Figure 13: NCS57-MPA-12L-S Modular Port Adapter (MPA)

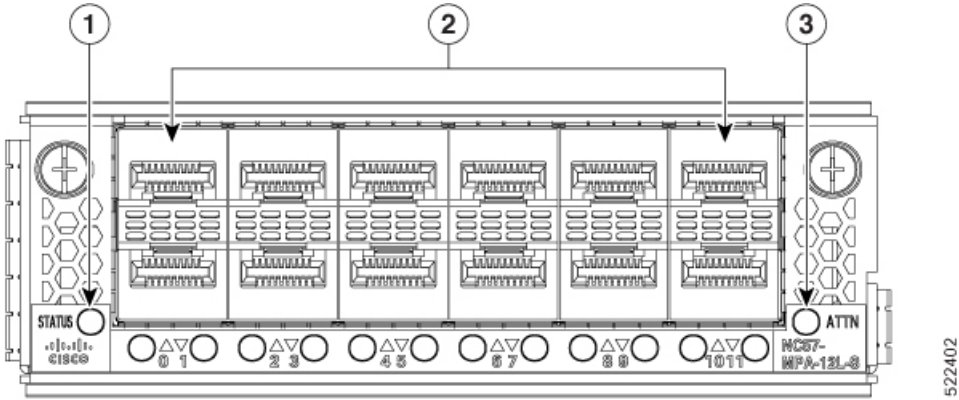

1	STATUS LED	3	ATTN LED
2	SFP56 ports and LEDs		

1-port 400GbE with CFP2-DCO + 1-Port 400GbE with QSFP-DD MPA

Table 6: Feature History Table

Hardware	Release Information	Feature Description
NCS57-MPA-1FH1D-S Modular Port Adapter	Release 7.8.1	<p>This release introduces NCS57-MPA-1FH1D-S, a 2-port 800GbE modular port adapter with one port supporting QSFP-DD and the other supporting CFP2-DCO optical transceivers.</p> <p>This MPA is supported in the NCS-57C3-MODS-SYS router and NCS57-MOD-S line card.</p> <p>For more information, see the Cisco Network Convergence System 5700 Series: Modular Port Adapters Data Sheet.</p>

The 2-port 800GbE MPA (NCS57-MPA-1FH1D-S) provides one port for QSFP-DD and one port for CFP2-DCO transceivers. The QSFP-DD port operates in 400GbE mode and supports 4x100G breakout mode, and the CFP2-DCO port operates in 400GbE mode and supports 4x100G, or 3x100G, or 2x100G, or 1x100G breakout modes.

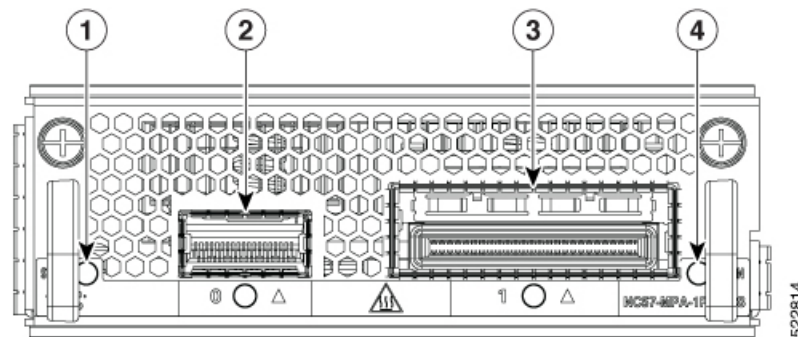

1	STATUS LED	3	CFP2-DCO port and LED
2	QSFP-DD port and LED	4	ATTN LED

Route Processor Card Overview

Route processor cards manage all routing operations on the Cisco NCS 5500 Series modular chassis.

NC55-RP

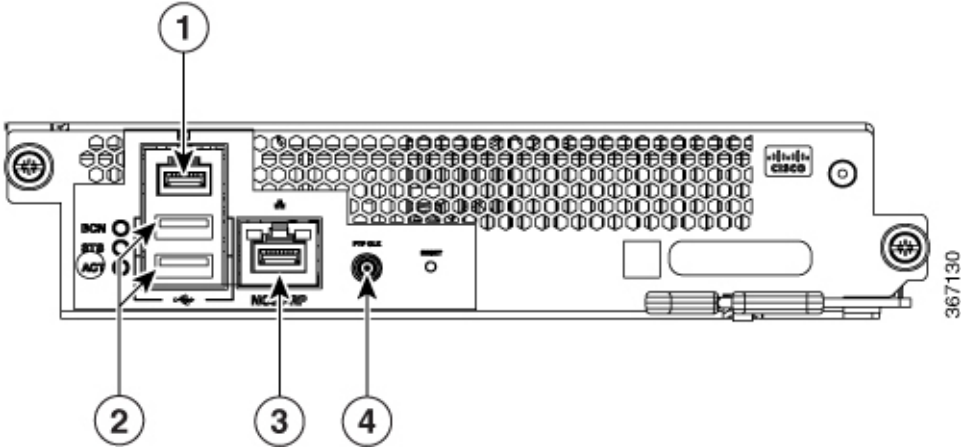

1	Console	3	Management Ethernet
2	USB (2)	4	Mini coax connector for 1 PPS input and output

NC55-RP-E

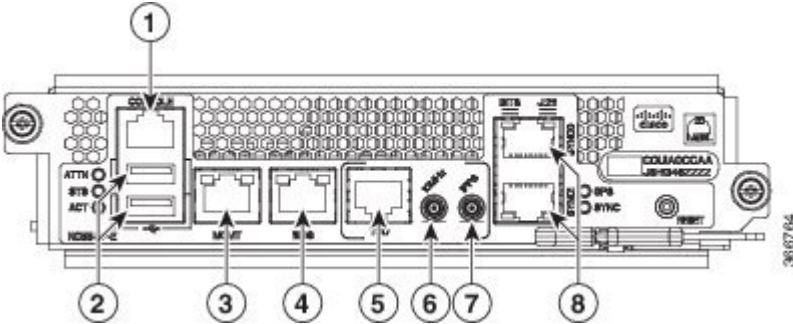

Note The NC55-RP-E supports Class-B timing.

1	Console	5	Shielded RJ-45 connector for Time-of-Day (TOD) interface, input and output
2	USB (2)	6	Mini coax connector for 10 MHz, input and output
3	Management Ethernet	7	Mini coax connector for 1 PPS, input and output
4	10/100/1000-Mbps Ethernet RJ-45 (Copper) port, supports 1588 Precision Time Protocol (PTP)	8	RJ-48 connector for BITS interface, input and output

NC55-RP2-E

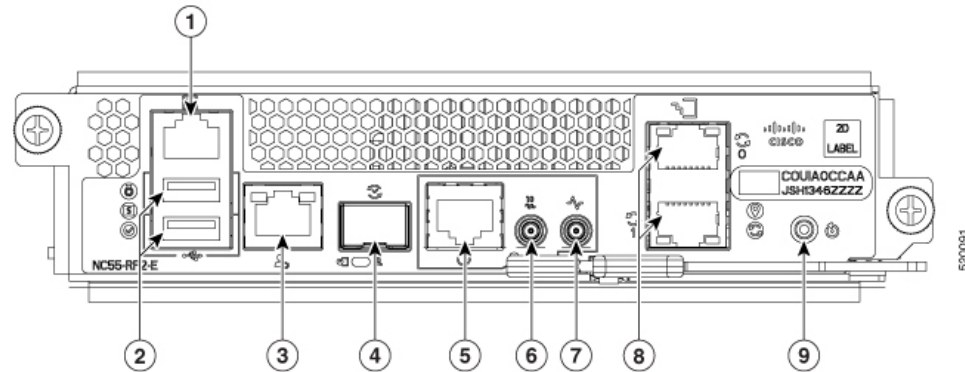

Note The NC55-RP2-E supports Class-B and Class-C timing.



Note Using a combination of RP2-E and RP-E is not supported on the same router.

1	Console	6	Mini coaxial connector for 10 MHz, input, and output
2	USB Port Type-A (2-ports). Only the USB drive that is inserted first gets detected.	7	Mini coaxial connector for 1 PPS, input, and output
3	Management Ethernet (10/100/1000-Mbps)	8	SyncE BITS/DTI/J.211
4	IEEE 1588 Precision Time Protocol (PTP)	9	Recessed reset button
5	G.703 Time-of-Day (TOD)		

Environmental and Physical Specifications

For environmental and physical specifications, refer to the *Environmental Properties* table in the [Cisco Network Convergence System 5500 Series Data Sheet](#).

Weight, Quantity and Power Consumption

For environmental and physical specifications, refer to the *Weight and Power Consumption* table and the *Cisco NCS 5500 Series Line Cards* table in the [Cisco Network Convergence System 5500 Series Data Sheet](#).

Airflow Direction

The airflow through the fan trays and power supplies on the Cisco NCS 5500 series modular router is from the port side intake (front-to-back cooling). To ensure proper airflow, you must make sure that when you install the router its air intake is positioned in a cold aisle and the air exhaust is positioned in a hot aisle.

Maximum Power Available to the Router

The maximum power available for operations depends on the input power from your power source, the number and output capabilities of your power supplies, and the power redundancy mode that you use.

The following table lists the amount of power available for power supplies depending on power inputs, numbers of power supplies, and the mode used.

Table 7: Feature History Table

Feature Name	Release Information	Feature Description
New DC Power Supply NC55-PWR-4.4KW-DC	Release 7.3.1	<p>This release introduces a new Power Supply Unit, NC55-PWR-4.4KW-DC.</p> <p>With the new 4.4 KW DC power supply (NC55-PWR-4.4KW-DC), feed redundancy is supported on the Cisco NCS 5504, Cisco NCS 5508, and Cisco NCS 5516 routers. The PSU supplies power to sensors, fan speeds, faults and alarms, and LED indicators. The firmware can detect AC or DC input types through input data sampling.</p>

Table 8: Maximum Power Available for a Router with 3KW AC Power Supplies

Power Inputs (220 V)	Power Supplies	Combined Mode	n+1 Redundancy Mode	n+n Redundancy Mode
1 input per PSU	1	3000 W	—	—
	2	6000 W	3000 W	3000 W
	3	9000 W	6000 W	3000 W
	4	12000 W	9000 W	6000 W
	5	15000 W	12000 W	6000 W
	6	18000 W	15000 W	9000 W
	7	21000 W	18000 W	9000 W
	8	24000 W	21000 W	12000 W
	9	27000W	24000W	12000W
	10	30000W	27000W	15000W

Table 9: Maximum Power Available for a Router with 3KW DC Power Supplies

Power Inputs (-48 VDC)	Power Supplies	Combined Mode	n+1 Redundancy Mode	n+n Redundancy Mode
2 inputs per PSU	1	3000 W	—	—
	2	6000 W	3000 W	3000 W
	3	9000 W	6000 W	4500 W
	4	12000 W	9000 W	6000 W
	5	15000 W	12000 W	7500 W
	6	18000 W	15000 W	9000 W
	7	21000 W	18000 W	10500 W
	8	24000 W	21000 W	12000 W
	9	27000W	24000W	13500
	10	30000W	27000W	15000W

Table 10: Maximum Power Available for a Router with 3.15KW HVAC/HVDC Power Supplies

Power Inputs (220 V)	Power Supplies	Combined Mode	n+1 Redundancy Mode	n+n Redundancy Mode
1 or 2 inputs per PSU	1	3150 W	—	—
	2	6300 W	3150 W	3150 W
	3	9450 W	6300 W	3150 W
	4	12600 W	9450 W	6300 W
	5	15750 W	12600 W	6300 W
	6	18900 W	15750 W	9450 W
	7	22050 W	18900 W	9450 W
	8	25200 W	22050 W	12600 W
	9	28350 W	25200 W	12600 W
	10	31500 W	28350 W	15750 W

Table 11: Maximum Power Available for a Router with 4.4KW DC Power Supplies

Power Inputs (-48 V DC)	Power Supplies	Combined Mode	n+1 Redundancy Mode	n+n Line Redundancy Mode ¹
3 inputs per PSU	1	4400 W	—	—
	2	8800 W	4400 W	6600 W
	3	13200 W	8800 W	—
	4	17600 W	13200 W	13200 W
	5	22000 W	17600 W	—
	6	26400 W	22000 W	19800 W
	7	30800 W	26400 W	—
	8	35200 W	30800 W	26400 W
	9	39600 W	35200 W	—
	10	44000 W	39600 W	33000 W

¹ n+n Line Redundancy wired A/B,A/B to 2-inputs of every pair of PSUs (loss of either bus)

Table 12: Maximum Power Available for a Router with 4.4KW Power Supplies (n+n Redundancy Mode with A-Bus Loss)

Power Inputs (-48 V DC)	Power Supplies	n+n Line Redundancy Mode ²
1 input per PSU	1	—
2 inputs per PSU	2	6600 W
1 input per PSU	3	—
2 inputs per PSU	4	13200 W
1 input per PSU	5	—
2 inputs per PSU	6	19800 W
1 input per PSU	7	—
2 inputs per PSU	8	26400 W
1 input per PSU	9	—
2 inputs per PSU	10	33000 W

² n+n Line Redundancy wired A/B/A, B/A/B to 3-inputs of every pair of PSUs (example: Loss of A-Bus)

Graceful Shutdown of DC PSU

If the DC input power to the DC PSU falls below 40V, graceful shutdown of the power supply is initiated, and the chassis is shutdown. To power up the chassis again, shut off the DC circuit at the circuit breaker, then turn on the DC circuit. The chassis will power up if the DC input power is above 43.5V.



Note You can disable the graceful shutdown of the DC PSU using the **environment graceful-shutdown disable** command in Admin Configuration mode. When graceful shutdown is disabled, the chassis will shut down if the DC input power falls below 38.5V +/- 1V. The chassis will recover (power on again) if the DC input power to the DC PSU is above 43.5V. In this mode, the long-term reliability of the router can be impacted if the DC input power continues to fluctuate between 38.5V and 43.5V (resulting in continuous power-on and power-off cycles).

Transceivers, Connectors, and Cables

Transceiver and Cable Specifications

To determine which transceivers and cables are supported by this router, refer to the Transceiver Module Group (TMG) Compatibility Matrix Tool:

<https://tmgmatrix.cisco.com>

To see the transceiver specifications and installation information, see [Cisco Transceiver Modules Install and Upgrade Guides](#).

RJ-45 Connectors

The RJ-45 connector connects Category 3, Category 5, Category 5e, Category 6, or Category 6A foil twisted-pair or unshielded twisted-pair cable from the external network to the following module interface connectors:

- Router chassis
 - CONSOLE port
 - MGMT ETH port



Caution To comply with GR-1089 intrabuilding, lightning immunity requirements, you must use a foil twisted-pair (FTP) cable that is properly grounded at both ends.

The following figure shows the RJ-45 connector.

Figure 14: RJ-45 Connector

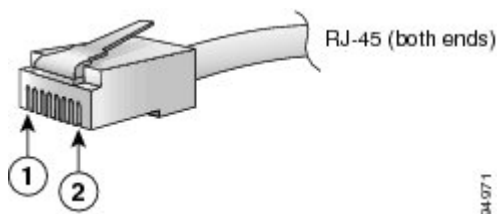

1	Pin 1	2	Pin 2
---	-------	---	-------

Pinouts

The following sections describe the pinouts for the Cisco NCS 5500 RP-E (NC55-RP-E) interfaces:

BITS Port Pinouts

The table below summarizes the BITS port pinouts.

Table 13: BITS Port Pinouts

Pin	Signal Name	Direction	Description
1	RX Ring	Input	Receive Ring
2	RX Tip	Input	Receive Tip
3	—	—	Not used

Pin	Signal Name	Direction	Description
4	TX Ring	Output	TX Ring
5	TX Tip	Output	TX Tip
6	–	–	Not used
7	–	–	Not used
8	–	–	Not used

Time-of-Day Port Pinouts

The table below summarizes the ToD/1-PPS port pinouts.

Table 14: RJ-45 ToD/1-PPS Port Pinouts

Pin	Signal Name	Direction	Description
1	–	–	–
2	–	–	–
3	1PPS_N	Output or Input	1PPS RS422 signal
4	GND	–	–
5	GND	–	–
6	1PPS_P	Output or Input	1PPS RS422 signal
7	TOD_N	Output or Input	Time-of-Day character
8	TOD_P	Output or Input	Time-of-Day character

Management and PTP Ethernet Port Pinouts

The table below summarizes the Management and Precision Time Protocol (PTP) Ethernet port pinouts.

Table 15: Management and PTP Ethernet Port Pinouts

Pin	Signal Name
1	TRP0+
2	TRP0-
3	TRP1+
4	TRP1-
5	TRP2+

Pin	Signal Name
6	TRP2-
7	TRP3+
8	TRP3-

USB Flash or MEM Port Pinouts

The table below summarizes the USB flash or MEM port pinouts.

Table 16: USB Flash or MEM Port Pinouts

Pin	Signal Name	Description
A1	Vcc	+5 VDC
A2	D-	Data -
A3	D+	Data +
A4	Gnd	Ground

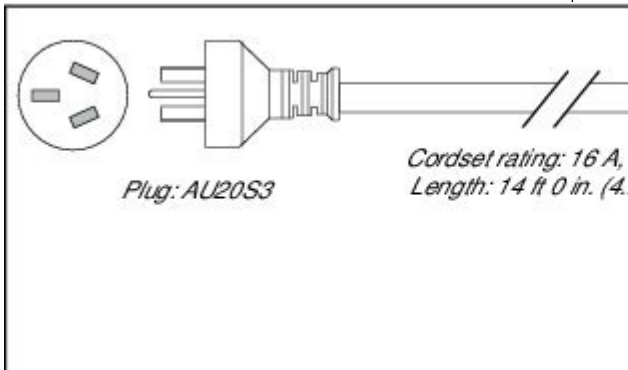

Power Supply Power Cord Specifications

Standard AC Power Cords

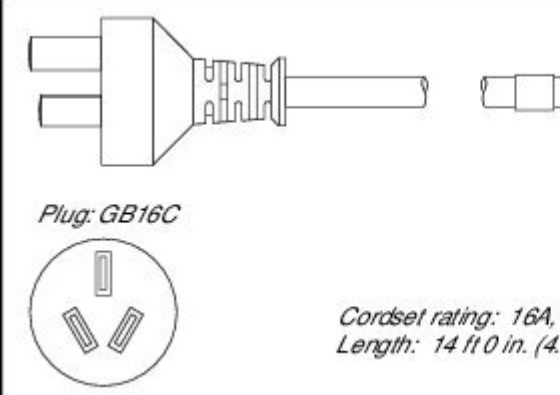
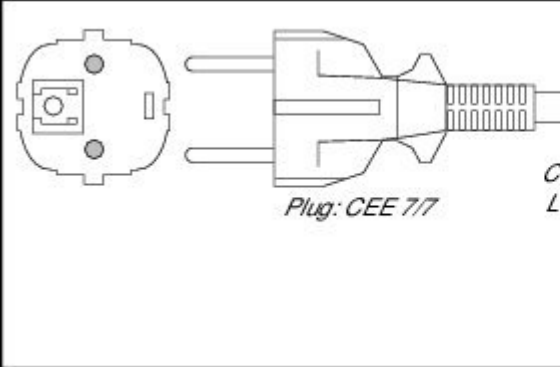
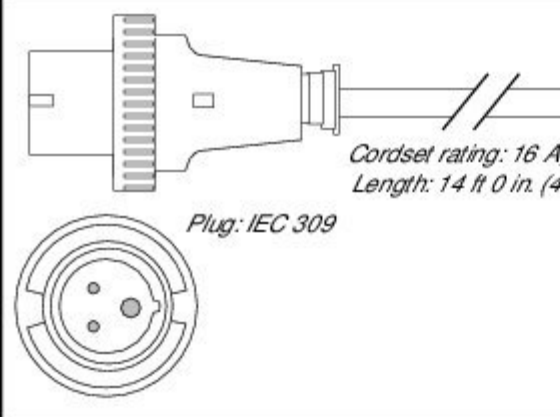
Locale	Part Number	Cord Set Rating	Power Cord Illustration
Australia and New Zealand	CAB-AC-16A-AUS	16A, 250 VAC	 <p>Plug: AU20S3</p> <p>Cordset rating: 16 A, Length: 14 ft 0 in. (4.27 m)</p>

Locale	Part Number	Cord Set Rating	Power Cord Illustration
Peoples Republic of China	CAB-AC-16A-CH	16A, 250 VAC	 <p>Plug: GB16C</p> <p>Cordset rating: 16A, 250VAC Length: 14 ft 0 in. (4.27m)</p>
Continental Europe	CAB-AC-2500W-EU	16A, 250 VAC	 <p>Plug: CEE 7/7</p> <p>Cordset rating: 16A, 250VAC Length: 14 ft 0 in. (4.27m)</p>
International	CAB-AC-2500W-INT	16A, 250 VAC	 <p>Plug: IEC 309</p> <p>Cordset rating: 16 A, 250VAC Length: 14 ft 0 in. (4.27m)</p>

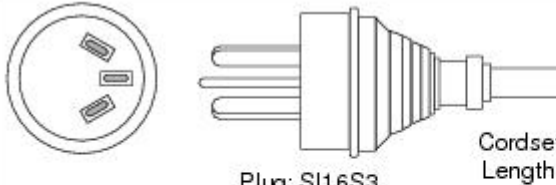
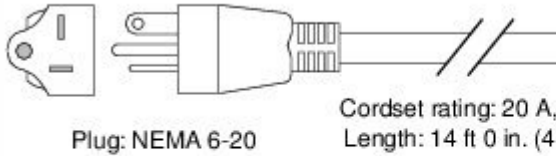
Power Supply Power Cord Specifications

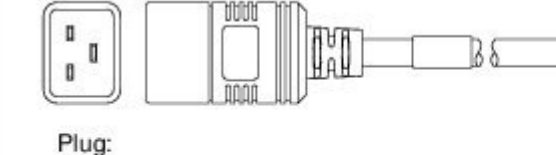
Locale	Part Number	Cord Set Rating	Power Cord Illustration
Israel	CAB-AC-2500W-ISRL	16A, 250 VAC	 <p>Plug: SI16S3 Cordset rating: 16 A, 250 V Length: 14 ft</p>
Japan and North America (non locking) 200-240 VAC operation	CAB-AC-2500W-US1	16A, 250 VAC	 <p>Plug: NEMA 6-20 Cordset rating: 20 A, 250 V Length: 14 ft 0 in. (4.26 m)</p>
Japan and North America (locking) 200-240 VAC operation	CAB-AC-C6K-TWLK	16A, 250 VAC	 <p>Plug: NEMA L6-20 Cordset rating: 20 A, 250 V Length: 14 ft 0 in. (4.26 m)</p>
Power distribution unit (PDU)	CAB-C19-CBN	16A, 250 VAC	 <p>Plug: IEC 60320 C20 Cordset rating: 16 A, 250 V Length: 9 ft 0 in. (2.7 m)</p>

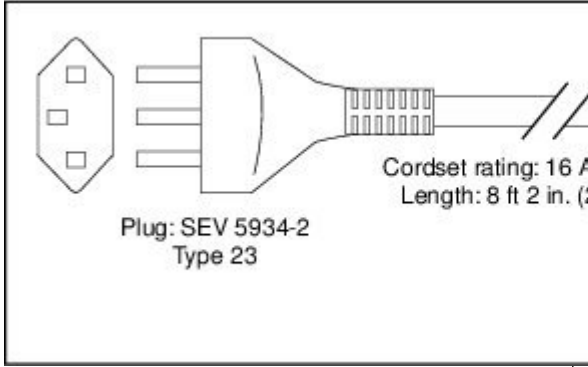
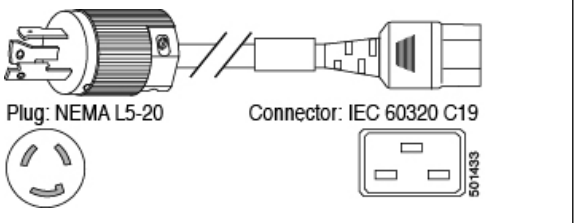
Locale	Part Number	Cord Set Rating	Power Cord Illustration
Switzerland	CAB-ACS-16	16A, 250 VAC	 <p>Cordset rating: 16 A Length: 8 ft 2 in. (2.5 m)</p> <p>Plug: SEV 5934-2 Type 23</p>
North America	CAB-L520P-C19-US	NEMA L5-20 to IEC-C19 6 feet (1.8 m)	 <p>Plug: NEMA L5-20</p> <p>Connector: IEC 60320 C19</p>

HVAC/HVDC Power Cords

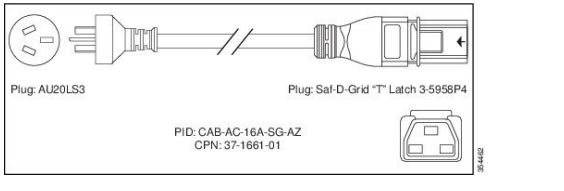
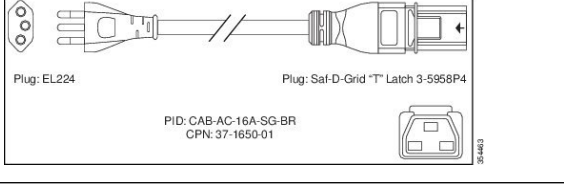
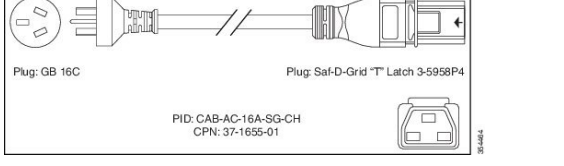
Locale	Part Number	Power Cord Set Rating	Power Cord Illustration
Australia	CAB-AC-16A-SG-AZ	16A, 250 VAC	 <p>Plug: AU20L53</p> <p>Plug: Saf-D-Grid "T" Latch 3-5958P4</p> <p>PID: CAB-AC-16A-SG-AZ CPN: 37-1661-01</p>
Brazil	CAB-AC-16A-SG-BR	16A, 250 VAC	 <p>Plug: EL224</p> <p>Plug: Saf-D-Grid "T" Latch 3-5958P4</p> <p>PID: CAB-AC-16A-SG-BR CPN: 37-1650-01</p>
China	CAB-AC-16A-SG-CH	16A, 250 VAC	 <p>Plug: GB 16C</p> <p>Plug: Saf-D-Grid "T" Latch 3-5958P4</p> <p>PID: CAB-AC-16A-SG-CH CPN: 37-1655-01</p>

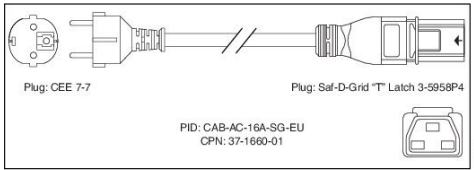
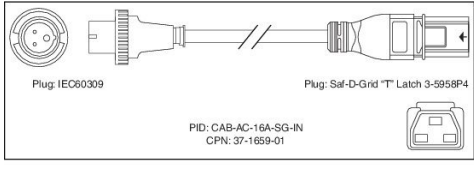
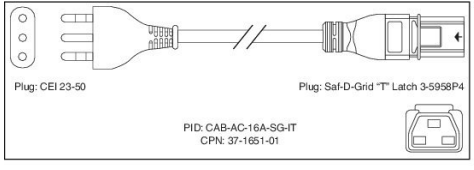
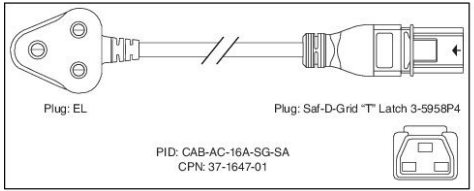
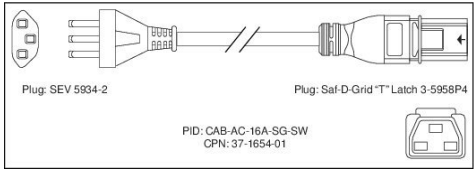
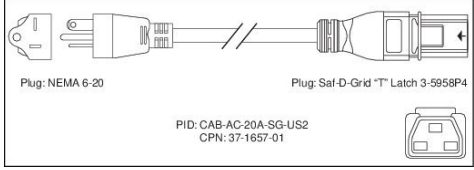
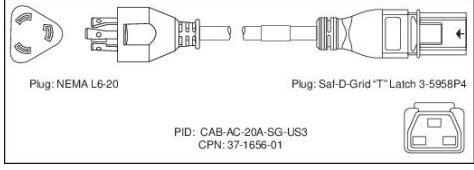
Locale	Part Number	Power Cord Set Rating	Power Cord Illustration
Europe	CAB-AC-16A-SG-EU	16A, 250 VAC	 <p>Plug: CEE 7-7</p> <p>Plug: Saf-D-Grid "T" Latch 3-5958P4</p> <p>PID: CAB-AC-16A-SG-EU CPN: 37-1660-01</p>
International/UK	CAB-AC-16A-SG-IN	16A, 250 VAC	 <p>Plug: IEC60309</p> <p>Plug: Saf-D-Grid "T" Latch 3-5958P4</p> <p>PID: CAB-AC-16A-SG-IN CPN: 37-1659-01</p>
Italy	CAB-AC-16A-SG-IT	16A, 250 VAC	 <p>Plug: CEI 23-50</p> <p>Plug: Saf-D-Grid "T" Latch 3-5958P4</p> <p>PID: CAB-AC-16A-SG-IT CPN: 37-1651-01</p>
South Africa	CAB-AC-16A-SG-SA	16A, 250 VAC	 <p>Plug: EL</p> <p>Plug: Saf-D-Grid "T" Latch 3-5958P4</p> <p>PID: CAB-AC-16A-SG-SA CPN: 37-1647-01</p>
Switzerland	CAB-AC-16A-SG-SW	16A, 250 VAC	 <p>Plug: SEV 5934-2</p> <p>Plug: Saf-D-Grid "T" Latch 3-5958P4</p> <p>PID: CAB-AC-16A-SG-SW CPN: 37-1654-01</p>
North America (non locking) 200-240 VAC operation	CAB-AC-20A-SG-US2	20A, 250 VAC	 <p>Plug: NEMA 6-20</p> <p>Plug: Saf-D-Grid "T" Latch 3-5958P4</p> <p>PID: CAB-AC-20A-SG-US2 CPN: 37-1657-01</p>
North America (locking) 200-240 VAC operation	CAB-AC-20A-SG-US3	20A, 250 VAC	 <p>Plug: NEMA L6-20</p> <p>Plug: Saf-D-Grid "T" Latch 3-5958P4</p> <p>PID: CAB-AC-20A-SG-US3 CPN: 37-1656-01</p>

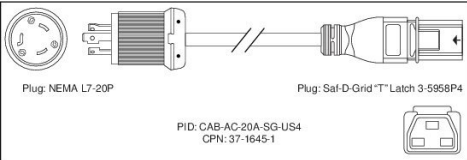
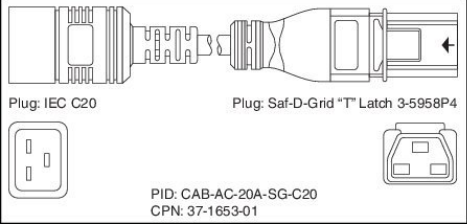
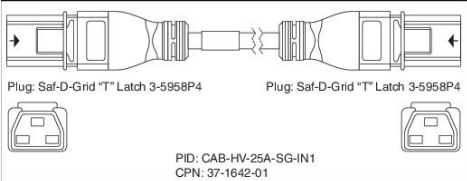
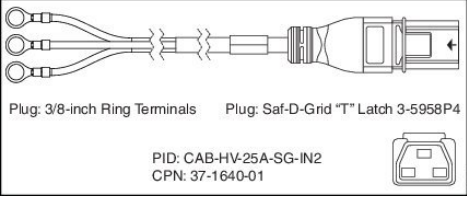
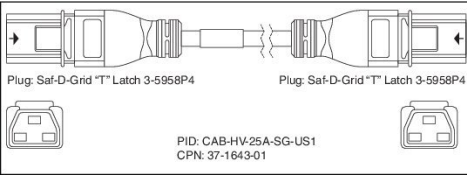
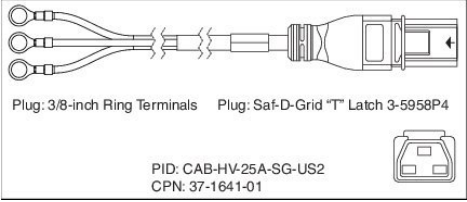
Locale	Part Number	Power Cord Set Rating	Power Cord Illustration
North America 277 VAC operation	CAB-AC-20A-SG-US4	20A, 277 VAC	 <p>Plug: NEMA L7-20P Plug: Saf-D-Grid "T" Latch 3-5958P4</p> <p>PID: CAB-AC-20A-SG-US4 CPN: 37-1645-1</p>
North America Cabinet Jumper Power Distribution unit (PDU)	CAB-AC-20A-SG-C20	20A, 250 VAC	 <p>Plug: IEC C20 Plug: Saf-D-Grid "T" Latch 3-5958P4</p> <p>PID: CAB-AC-20A-SG-C20 CPN: 37-1653-01</p>
International, Saf-D-Grid/Saf-D-Grid	CAB-HV-25A-SG-IN1	20A, 400 VDC	 <p>Plug: Saf-D-Grid "T" Latch 3-5958P4 Plug: Saf-D-Grid "T" Latch 3-5958P4</p> <p>PID: CAB-HV-25A-SG-IN1 CPN: 37-1642-01</p>
International, Ring Terminal source plug, Ring Terminal/Saf-D-Grid	CAB-HV-25A-SG-IN2	20A, 300 VAC/500 VDC	 <p>Plug: 3/8-inch Ring Terminals Plug: Saf-D-Grid "T" Latch 3-5958P4</p> <p>PID: CAB-HV-25A-SG-IN2 CPN: 37-1640-01</p>
North America, Saf-D-Grid/Saf-D-Grid	CAB-HV-25A-SG-US1	20A, 400 VDC	 <p>Plug: Saf-D-Grid "T" Latch 3-5958P4 Plug: Saf-D-Grid "T" Latch 3-5958P4</p> <p>PID: CAB-HV-25A-SG-US1 CPN: 37-1643-01</p>
North America, Ring Terminal source plug, Ring Terminal/Saf-D-Grid	CAB-HV-25A-SG-US2	20A, 300 VAC/500 VDC	 <p>Plug: 3/8-inch Ring Terminals Plug: Saf-D-Grid "T" Latch 3-5958P4</p> <p>PID: CAB-HV-25A-SG-US2 CPN: 37-1641-01</p>



CHAPTER 2

Prepare for Installation



Note The images in this chapter are only for representation purposes, unless specified otherwise. The chassis' actual appearance and size may vary.

- [Review Installation Roadmap, on page 43](#)
- [Review Safety Guidelines, on page 43](#)
- [Cautions and Regulatory Compliance Statements for NEBS, on page 44](#)
- [Review Installation Guidelines, on page 45](#)
- [Review Site Maintenance Guidelines , on page 45](#)
- [Procure Tools and Equipment, on page 48](#)
- [Prepare Your Location , on page 50](#)
- [Prepare Yourself , on page 52](#)
- [Prepare Rack for Chassis Installation, on page 53](#)

Review Installation Roadmap

The following figure lists the steps to install Cisco NCS 5500 Series chassis and its components and prepare the system for operation. For information about a step, see the respective section of this installation guide.

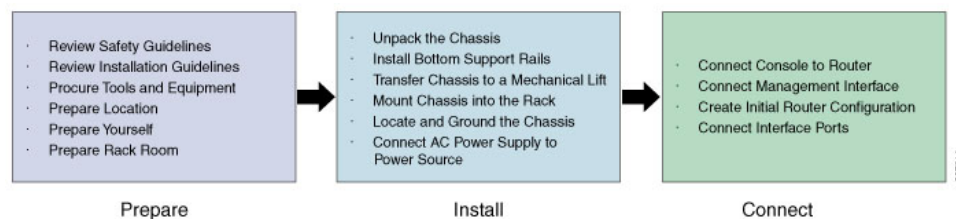

Review Safety Guidelines

Before you perform any procedure in this document, review the safety guidelines in this section to avoid injuring yourself or damaging the equipment. The following guidelines are for your safety and to protect equipment. Because the guidelines do not include all hazards, be constantly alert.

- Keep the work area clear, smoke and dust-free during and after installation. Do not allow dirt or debris to enter into any laser-based components.
- Do not wear loose clothing, jewelry, or other items that could get caught in the router or other associated components.
- Cisco equipment operates safely when used in accordance with its specifications and product-usage instructions.
- Be sure to power down a fixed configuration PDU or modular configuration power shelf before removing it from the chassis.
- If potentially hazardous conditions exist, do not work alone.
- Take care when connecting multiple units to the supply circuit so that wiring is not overloaded.
- This equipment must be grounded. Never defeat the ground conductor or operate the equipment in the absence of a suitably installed ground conductor. Contact the appropriate electrical inspection authority or an electrician if you are uncertain about whether suitable grounding is available.
- To prevent personal injury or damage to the chassis, never attempt to lift or tilt the chassis using the handles on modules (such as power supplies, fans, or cards); these types of handles are not designed to support the weight of the unit.
- Hazardous voltage or energy is present on the backplane when the system is operating. Use caution when servicing.
- When installing or replacing the unit, the ground connection must always be made first and disconnected last.
- The rack stabilizing mechanism must be in place, or the rack must be bolted to the floor before you slide the unit out for servicing. Failure to stabilize the rack may cause the rack to tip over.

**Warning**

Invisible laser radiation may be emitted from disconnected fibers or connectors. Do not stare into beams or view directly with optical instruments. Statement 1051

Cautions and Regulatory Compliance Statements for NEBS

The following are NEBS GR-1089-CORE cautions, regulatory compliance statements, and requirements:

- The intra-building port(s) of the equipment or subassembly must use shielded intra-building cabling/wiring that is grounded at both ends.

**Caution**

The intra-building port(s) of the equipment or subassembly is suitable for connection to intra-building or unexposed wiring or cabling only. The intra-building port(s) of the equipment or subassembly must not be metallically connected to interfaces which connect to the OSP or its wiring. These interfaces are designed for use as intra-building interfaces only (Type 2 or Type 4 ports as described in GR-1089-CORE) and require isolation from the exposed OSP cabling. The addition of primary protectors is not sufficient protection in order to connect these interfaces metallically to OSP wiring.

- Products that have AC power ports that are intended for deployments where an external Surge Protective Device (SPD) is utilized at the AC power service equipment (see definition in National Electric Code).
- This product is designed for a Common Bonding Network (CBN) installation.
- This product can be installed in network telecommunication facilities or locations where the National Electric Code applies.
- An electrical conducting path shall exist between the product chassis and the metal surface of the enclosure or rack in which it is mounted or to a grounding conductor. Electrical continuity shall be provided by using thread-forming type mounting screws that remove any paint or nonconductive coatings and establish a metal-to-metal contact. Any paint or other nonconductive coatings shall be removed on the surfaces between the mounting hardware and the enclosure or rack. The surfaces shall be cleaned and an antioxidant applied before installation.
- The DC return connection to this system should remain isolated from the system frame and chassis (DC-I).
- The nominal DC operating voltage -48 VDC.

Review Installation Guidelines

Before installing the chassis, verify that these guidelines are met:

- Site is properly prepared so that there is sufficient room for installation and maintenance. For specifications on the clearances required for chassis installation, see [Clearance Requirements, on page 54](#).
- Operating environment is within the ranges listed in [Environmental and Physical Specifications, on page 29](#)
- Chassis is mounted at the bottom of the rack if it is the only unit in the rack.
- When mounting the chassis in a partially filled rack, load the rack from the bottom to the top with the heaviest component at the bottom of the rack.
- If the rack is provided with stabilizing devices, install the stabilizers before mounting or servicing the chassis in the rack.
- Airflow around the chassis and through the vents is unrestricted.
- Cabling is away from sources of electrical noise, such as radios, power lines, and fluorescent lighting fixtures. Make sure that the cabling is safely away from other devices that might damage the cables.
- For cable requirements for optical module connections, see the [Transceivers, Connectors, and Cables, on page 33](#) section. Each port must match the wave-length specifications on the other end of the cable, and the cable must not exceed the maximum cable length.

Review Site Maintenance Guidelines

This equipment requires specific environmental operating conditions such as temperature, humidity, and altitude for better performance and reliability. The following sections provide guidelines for installation of

the equipment to ensure operating conditions are within specified limits mentioned in the [Cisco Network Convergence System 5500 Series Modular Chassis Data Sheet](#).

Temperature and Humidity

- Maximum allowable temperature and humidity levels must be within the values mentioned in the data sheets.
- Optimum operating temperature and humidity are as follows:
 - Temperature range is from 64°F to 80°F (18°C to 27°C)
 - Humidity within 40% to 50% RH
- Always maintain absolute humidity levels less than 0.024 Kg of water vapor/Kg of dry air as per GR-63-CORE Table 4-4.
- We do not recommend installations where condensation may occur or where equipment is exposed to high humidity for long duration.
- Short term exposure: Equipment should not be exposed to higher humidity (greater than 85% RH) in line with GR-63-CORE.



Note Short term exposure refers to a period of not more than 96 consecutive hours and a total of not more than 15 days in 1 year. (This number refers to a total of 360 hours in any given year, but no more than 15 occurrences during that 1-year period.)

- Ensure that thermometers and hygrometers are present in the installation site so that optimal temperature and humidity levels can be monitored and maintained for the proper functioning of Cisco data networking equipment. When taking measurements, keep the instrument 3 ft (1m) above the floor level and 3 ft (1m) away from equipment air inlet.
- Installation in highly corrosive areas is not recommended. Examples of highly corrosive areas include the following: near seas, rivers, and large water bodies where high humidity persist for long periods of time; highly polluted areas such as sites less than 10 meters from high traffics roadway; areas with high industrial pollutants.

Environmental Pollutants

- For better reliability of the equipment, the recommended limits for allowable solid pollutants concentration shall be within the limits mentioned below or as per GR-63-CORE Table 2-4.

Type of Particles	Allowable Particulate matter concentration range
PM2.5 + PM10	< 20 µg/m ³

- Solid particulate concentration level measurements:
 - Solid pollutants such as dust concentration can be measured using instruments like PM2.5 and PM10 particle counters.
 - We recommend checking concentration of pollutants periodically:

- **General recommendation for clean installation sites:** If the installation site is clean and has low solid-particulate concentration levels over a 3-month period, we recommend checking the concentration level once per month.
- **Recommendation for installation sites prone to high particulate concentration levels:** If the site location is listed below, we recommend checking the concentration levels once per week.
 - Near high automobile traffic areas or busy streets
 - Near construction areas
 - Near factories that emit smoke or other solid particulates
- Commercially available instruments can be used to measure the particulate concentration level. When taking measurements, keep the instrument 3 ft (1m) above the floor level and 3 ft (1m) away from equipment air inlet.
- Necessary protection should be provided to ensure the equipment is not exposed to high concentration level of pollutants. Follow these guidelines for minimizing solid particulate concentration levels:
 - Minimize air leaks (unfiltered external air entering equipment room) by closing ventilations or air entry points that are not desired.
 - Use High Efficiency Particulate Air (HEPA) filters for filtering suspended solid particles from the air. These filters can be part of the Heating, Ventilating, and Air-Conditioning (HVAC) of the rooms.
 - Alternatively, air purifiers can be used to filter suspended solid particles from air. These can be placed at strategic locations in the room such that air is purified before entering equipment.
 - It is common for dust particles to settle on the floor. Depending on the temperature and velocity of the air, there is a probability that dust particles may get into the air and cause negative impact on the equipment. To prevent this, dust particles can be extracted using vacuum machines.
- Negative effect of high concentration of solid particle concentration level:
 - Presence of high concentration of solid pollutants could reduce the product life significantly as per GR-1274-CORE.
 - Product service life is inversely proportional to the dust concentration level, for example: product service life will be halved if the dust concentration level increases by two.

Altitude

- The chassis is intended to operate in the temperate and altitude range described in the data sheet.
- The allowable operating temperature of the equipment reduces at the rate of 34°F (1°C) per every 984 ft (300 m) increase in the altitude.

Air Filters

- The NCS 5500 modular chassis are designed to accommodate air filters. We recommend using air filters in normal operating conditions.

Air filters are present in the door kit. The door kit must be ordered separately. To replace an existing air filter, you must order the air filter separately. For information on PIDs, see the [\(Optional\) Install Air Filter, Cable Management Bracket, or Door Kit on a Chassis](#), on page 71 section.

- A periodic health check of the filter, every three months based on the level of dust in the environment, helps in avoiding over clogging of the filters and provide a better life. This product's filter is used as a single-use component. If the product is installed in a controlled environment, check and replace the filter every three months, otherwise replace the filter every month.

Best Practices

- For additional information on best practices, please refer to [Guidelines and Best Practices for the Installation and Maintenance of Data Networking Equipment](#).

Procure Tools and Equipment

Obtain these necessary tools and equipment for installing the chassis:

- Number 1 and number 2 Phillips screwdrivers with torque capability to rack-mount the chassis
- 3/16-inch flat-blade screwdriver
- Tape measure and level
- ESD wrist strap or other grounding device
- Antistatic mat or antistatic foam
- A Torx T15 screwdriver, or the Torx T15 key to install adapters
- Grounding cable (6 AWG recommended), sized according to local and national installation requirements; the required length depends on the proximity of the switch to proper grounding facilities
- Ground lug (1)
- Crimping tool large enough to accommodate the girth of the lug
- Wire-stripping tool
- (ANSI) Pair of 19-inch mounting brackets
- M4 screws to fix brackets (16)
- M4 screws to fix ground lug (2)

Rack Mount and Accessory Kits



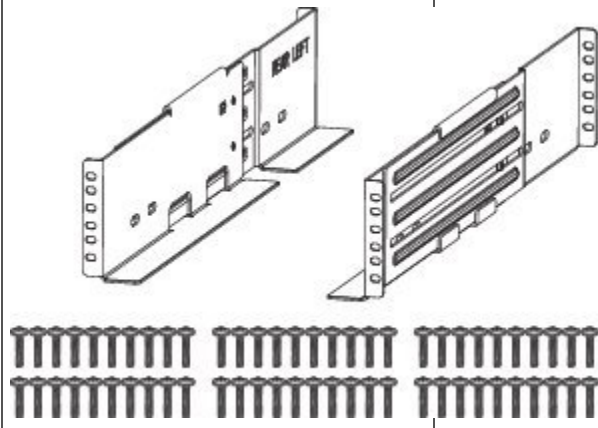

Rack Mount Kit

Rack mount kit for the Cisco 5504 (NC55-5504-RMK), Cisco NCS 5508 (NC55-5508-RMK), or NCS 5516 (NC55-5516-RMK) chassis includes the following:

Illustration	Description	Quantity
	<p>1. Phillips screws (20) and nuts (20)</p> <p>n. Phillips screws (20)</p> <p>Phillips screws (20)</p> <p>Bottom-support rails (2) – Supports 4-post rack from 24" ~ 34"</p> <p>Extended Rack Mounting Kit (NC55-5500-RMK-E) contains adjustable bottom-support rails (2) that support depths of 4-post rack from 32" ~ 42"</p>	<p>1 kit</p>

Router Accessory Kit

Router accessory kit (NC55-5500-ACC-KIT) includes the following:

Illustration	Description	Quantity
	<p>RJ-45 rollover cable</p>	<p>1</p>
	<p>DB-9F/RJ-45F PC terminal</p>	<p>1</p>
<p>Ground lug kit</p> 	<p>Ground lug kit</p> <ul style="list-style-type: none"> • Two-hole lug (1) • M4 x 8-mm Phillips pan-head screws (2) 	<p>1 kit</p>
	<p>Cable tie, 8.5 inches (10)</p>	<p>1</p>
<p>ESD wrist strap</p> 	<p>ESD wrist strap (disposable)</p>	<p>1</p>
<p>Not applicable</p>	<p>Hazardous substances list for customers in China</p>	<p>1</p>
<p>Not applicable</p>	<p>Cisco Information Packet</p>	<p>1</p>
<p>Not applicable</p>	<p>1-Year Limited Warranty for Hardware</p>	<p>1</p>

Additional Hardware Components

If you purchased this product through a Cisco reseller, you might receive additional contents in your kit, such as documentation, hardware, and power cables.

The shipped cables depend on your specification when placing an order. See the [Power Supply Power Cord Specifications](#) section for information on the available power cords.

If you notice any discrepancies or damage, send the following information to your customer service representative by email:

- Invoice number of the shipper (see the packing slip)
- Model and serial number of the missing or damaged unit
- Description of the problem and how it affects the installation
- Photos of the damage to external packaging, internal packaging, and product

Prepare Your Location

This section illustrates how the building that houses the chassis must be properly grounded to the earth ground.

Figure 15: Building with Rack Room Connected to Earth Ground

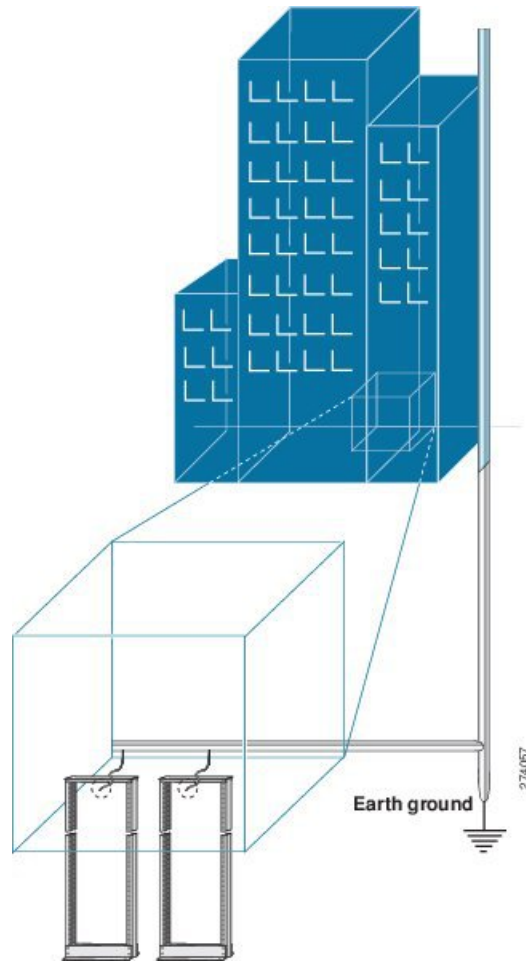

Airflow for Site Planning

Table 17: Estimated Airflow with 2nd Generation Fans (FAN2)

Chassis	Ambient Temperature	Airflow through Chassis (CFM)
NCS 5504	77°F (25°C)	611
	104°F (40°C)	1137
NCS 5508	77°F (25°C)	990
	104°F (40°C)	2010
NCS 5516	77°F (25°C)	1850
	104°F (40°C)	3800

Prepare Yourself

This section illustrates how to prepare yourself before removing the chassis from the sealed antistatic bag. The figures show how to cuff the ESD strap around the wrist and the ground cord that connects the cuff to the ground. ESD wrist straps are the primary means of controlling static charge on personnel.

Figure 16: Wearing the ESD Strap

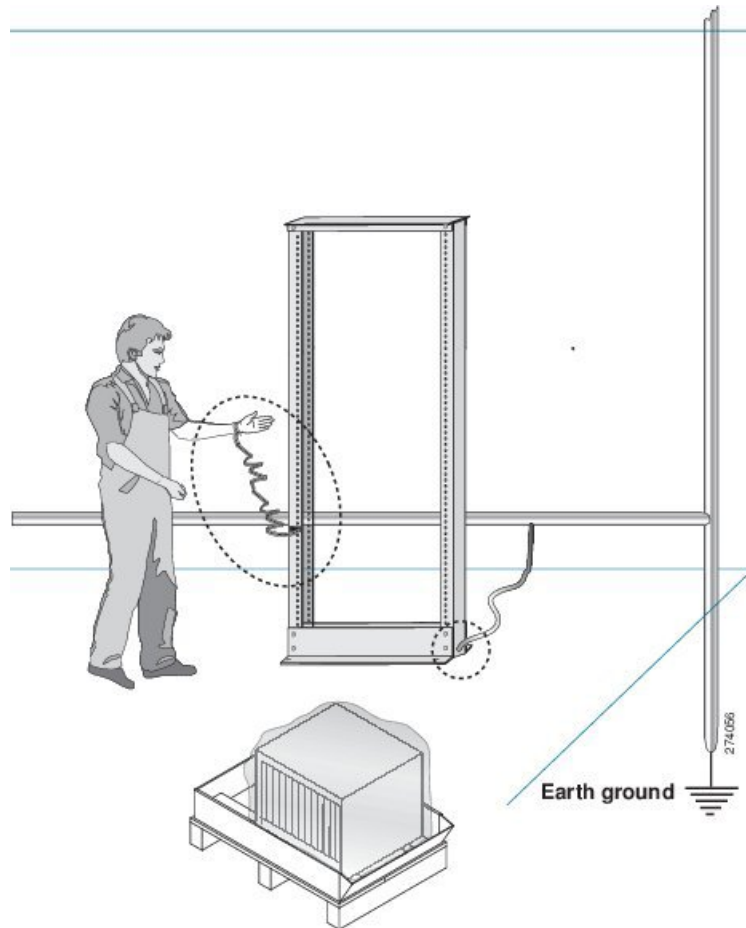
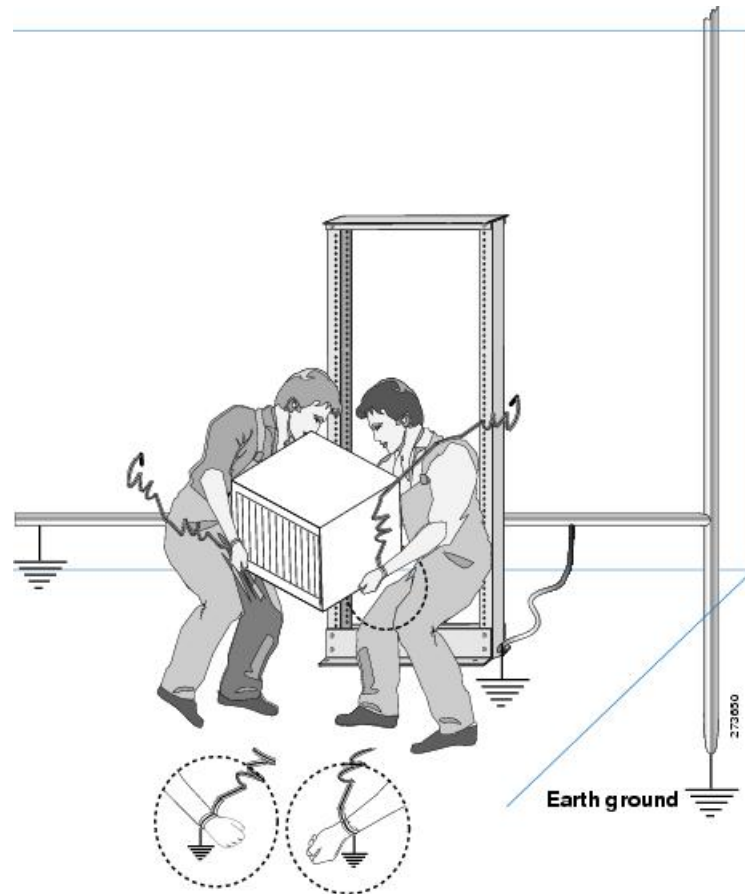

Figure 17: Handling the Chassis



Prepare Rack for Chassis Installation

Install the NCS 5500 Series chassis into a standard 19-inch, four-post Electronic Industries Alliance (EIA) cabinet or rack with mounting rails that conform to English universal hole spacing per section 1 of the ANSI/EIA-310-D-1992 standard.

The spacing between the posts of the rack must be wide enough to accommodate the width of the chassis.

Before you move the chassis or mount the chassis into the rack, we recommend that you do the following:

-
- Step 1** Place the rack where you plan to install the chassis. Ensure that the rack that the chassis is being installed is grounded to earth ground as instructed in [Prepare Your Location](#), on page 50. Also verify the clearance around the chassis as shown in [Clearance Requirements](#), on page 54.
 - Step 2** Secure the rack to the floor.

To bolt the rack to the floor, a floor bolt kit (also called an anchor embedment kit) is required. For information on bolting the rack to the floor, consult a company that specializes in floor mounting kits (such as Hilti; see Hilti.com for details). Make sure that floor mounting bolts are accessible, especially if annual retorquing of bolts is required.

Clearance Requirements

You must provide adequate clearance between the chassis and any other rack, device, or structure in order to properly install the chassis, route cables, provide airflow, and maintain the router.

For the clearances required for an installation of NCS 5504 chassis, see the following figure.

Figure 18: Clearances Required Around the Chassis for NCS 5504

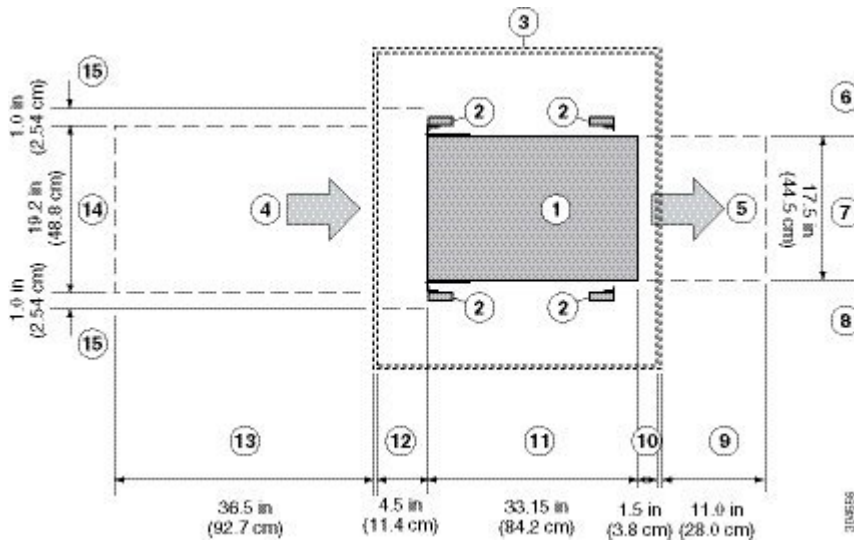

1	Chassis	9	Rear service cle
2	Vertical rack-mount posts and rails	10	Clearance requi
3	Nearest object or inside of cabinet (no side clearance required)	11	Chassis depth
4	Air intake from the cold aisle for all modules and power supplies	12	Clearance requi (used) or the edg door
5	Air exhaust to the hot aisle for all modules and power supplies	13	Clearance requi
6	No left-side clearance required (no airflow on left side)	14	Width of the cha
7	Chassis width	15	Side clearance r (keep this area c full rotation of t
8	No right-side clearance required (no airflow on right side)		

For the clearances required for an installation of NCS 5508 and NCS 5516 chassis, see the following figure.

Figure 19: Clearances Required Around the Chassis for NCS 5508 and NCS 5516

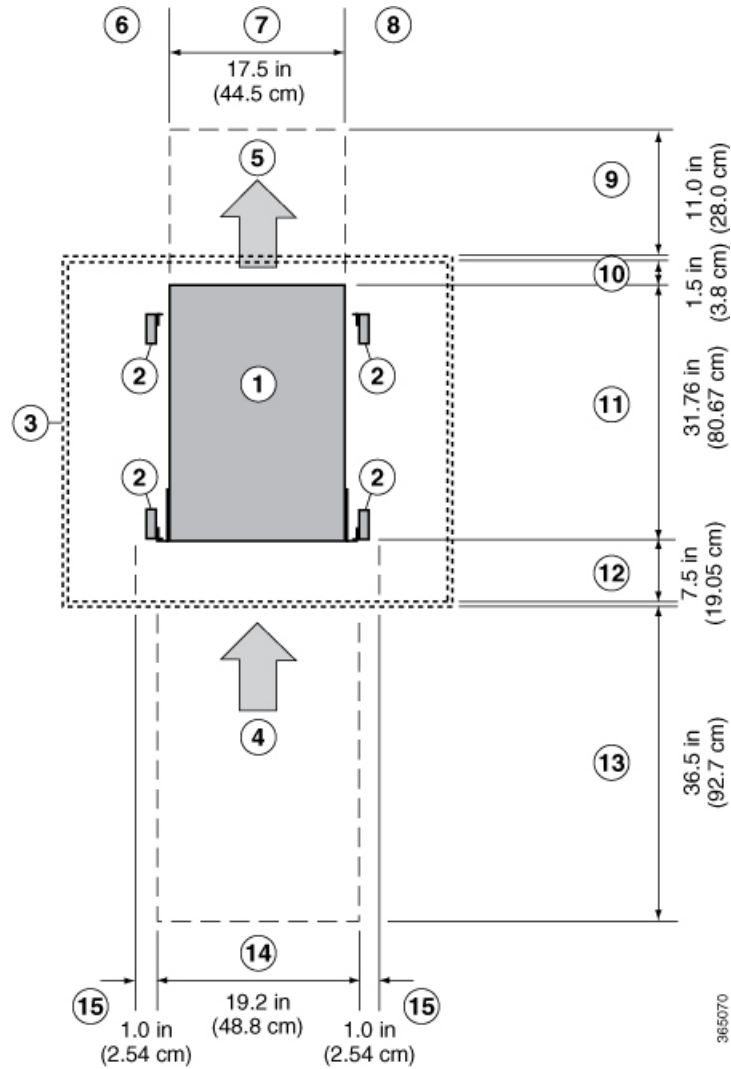

365070

1	Chassis	9	Rear service clearance required to repla
2	Vertical rack-mount posts and rails	10	Clearance required for module handles
3	Nearest object or inside of cabinet (no side clearance required)	11	Chassis depth
4	Air intake from the cold aisle for all modules and power supplies	12	Clearance required between the front of chassis (if door is used) or the edge of the cold aisle (if no door)
5	Air exhaust to the hot aisle for all modules and power supplies	13	Clearance required for installing the chassis
6	No left-side clearance required (no airflow on left side)	14	Width of the chassis plus vertical mount

7	Chassis width	15	Side clearance required by the front of the chassis (keep this area clear of rack, cable management, and full rotation of the ejector levers)
8	No right-side clearance required (no airflow on right side)		



CHAPTER 3

Install the Chassis



Note The images in this chapter are only for representation purposes, unless specified otherwise. The chassis' actual appearance and size may vary.

- [Unpack the Chassis, on page 57](#)
- [Install Bottom-Support Rails, on page 58](#)
- [Transfer Chassis to a Mechanical Lifting Device, on page 60](#)
- [\(Optional\) Install the Rear Chassis Brackets, on page 62](#)
- [Mount Chassis Into the Rack, on page 65](#)
- [\(Optional\) Install Air Filter, Cable Management Bracket, or Door Kit on a Chassis , on page 71](#)
- [Attach Front Door to NCS 5504 and NCS 5508 Chassis, on page 86](#)
- [Replace Chassis Door Foam Air Filters on the NCS 5504, on page 88](#)
- [Ground the Front ID Door, on page 92](#)
- [Locate and Ground the Chassis, on page 96](#)
- [Connect AC Power Supply to AC Power Source, on page 99](#)
- [Connect 3kW DC Power Supply to DC Power Source , on page 99](#)
- [Connect 4.4kW DC Power Supply to DC Power Source , on page 101](#)
- [Connect HVAC/HVDC Power Supply to Power Source, on page 104](#)

Unpack the Chassis



Tip Be sure to save the packaging in case you need to return any of the components product.

Ensure there is sufficient room around the chassis pallet for unpacking. For information about the chassis dimensions and clearance requirements see, [Clearance Requirements, on page 54](#).

Carefully move the pallet containing the chassis to the staging area where you plan on unpacking it.

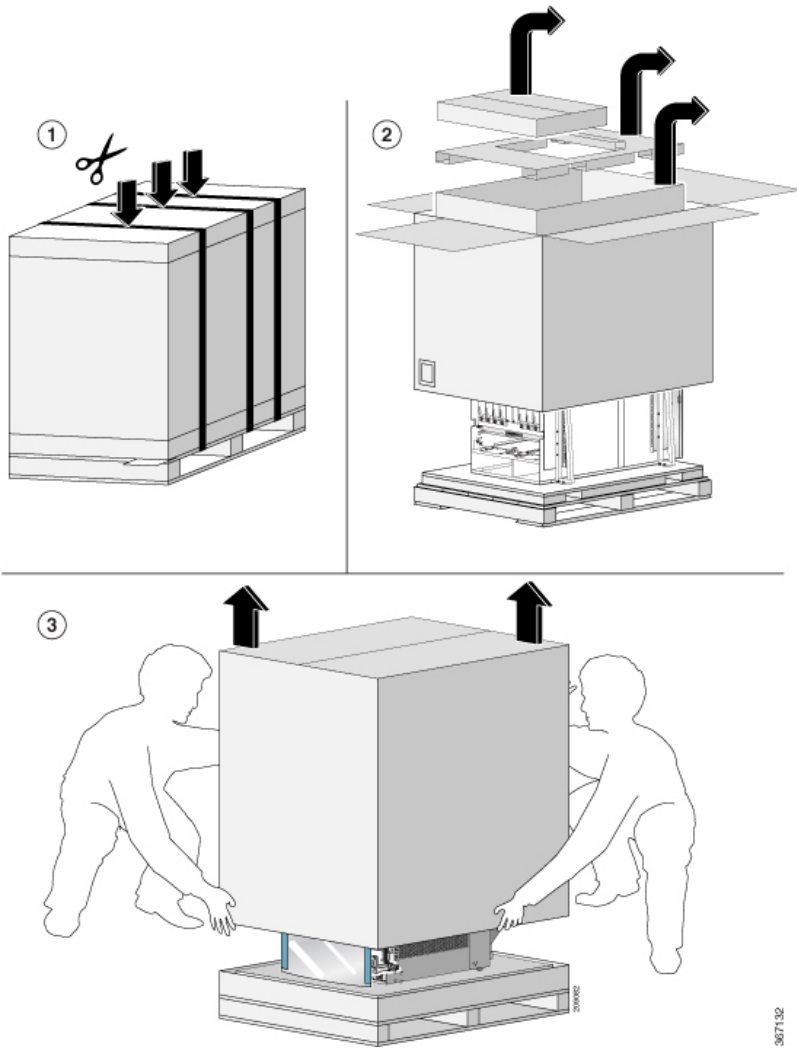

Leave the chassis on the pallet until you are ready to move and install the chassis in a rack.

Install Bottom-Support Rails

The bottom-support rails support the weight of the router chassis in the rack. To maximize the stability of the rack, you must attach these rails at the lowest possible rack unit (RU).

Step 1 Position one of the two adjustable bottom-support rails at the lowest possible RU in the rack and adjust the length of each rail so that it stretches from the outer edges of the front and rear vertical mounting rails on the rack. Check spacing considerations.

Note You can expand the rail so that its mounting brackets are spaced between 24 to 32 inches (61.0 to 81.3 cm).

Figure 20: Position Bottom-Support Rails

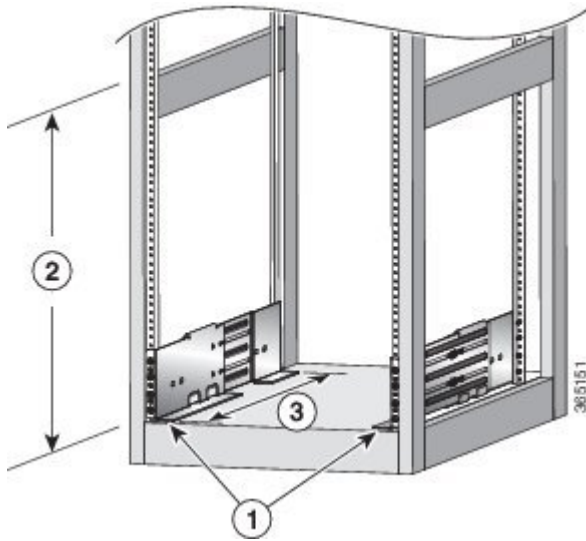

1	Position two bottom-support rails at the lowest RU on the rack.
2	<p>NCS 5504: Allow at least 7.1 RU (12.43 inches [31.6 cm]) for each chassis.</p> <p>NCS 5508: Allow at least 13 RU (22.7 in [57.8 cm]) for each chassis.</p> <p>NCS 5516: Allow at least 21 (36.7 in [93.21 cm]) RU for each chassis.</p>
3	Distance between front and rear vertical rails must be 24 to 32 inches (61.0 to 81.3 cm).

Step 2

Attach the bottom-support rail to the rack using a Phillips torque screwdriver on three M6 x 19 mm or 12-24 x 3/4 inch screws for each end of the rail (using a total of 6 screws for the rail as shown in the following figure) and tighten each screw to 40 in-lbs (4.5 N.m) of torque.

Figure 21: Attach Bottom-Support Rails to a Rack

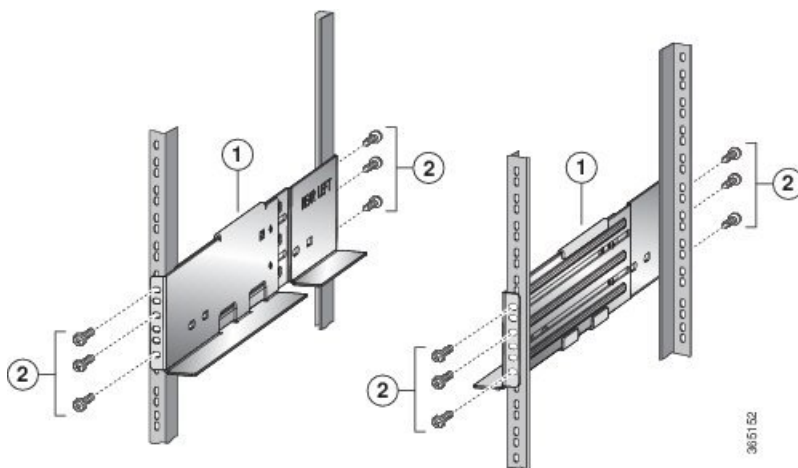

1	Adjustable bottom-support rails (2)	2	M6 x 19 mm (or 12-24 x 3/4 in.) Phillips screws (at least 6 per rail)
---	-------------------------------------	---	---

Note Use at least three screws on each end of each bottom-support rail.

Step 3 Repeat Steps 1 and 2 to attach the other bottom-support rail to the rack.

Note Make sure that the two bottom-support rails are level with one another. If they are not level, adjust the higher rail down to the level of the lower rail.

What to do next

Mount the chassis into the rack.

Transfer Chassis to a Mechanical Lifting Device

Step 1 Place the mechanical lifting device in front of the chassis on the pallet (PLIM side) as shown in [Figure 22: Align the Lifting Device In Front of the Chassis on the Pallet](#) , on page 60 .

Figure 22: Align the Lifting Device In Front of the Chassis on the Pallet



- Step 2** Prepare to use the mechanical lifting device by placing a piece of cardboard on the surface of the lift (to prevent scratching).
- Step 3** With at least two or three people move the chassis carefully from the pallet onto the lifting device as shown in [Figure 23: Move the Chassis On To the Lifting Device](#), on page 61 .

Figure 23: Move the Chassis On To the Lifting Device

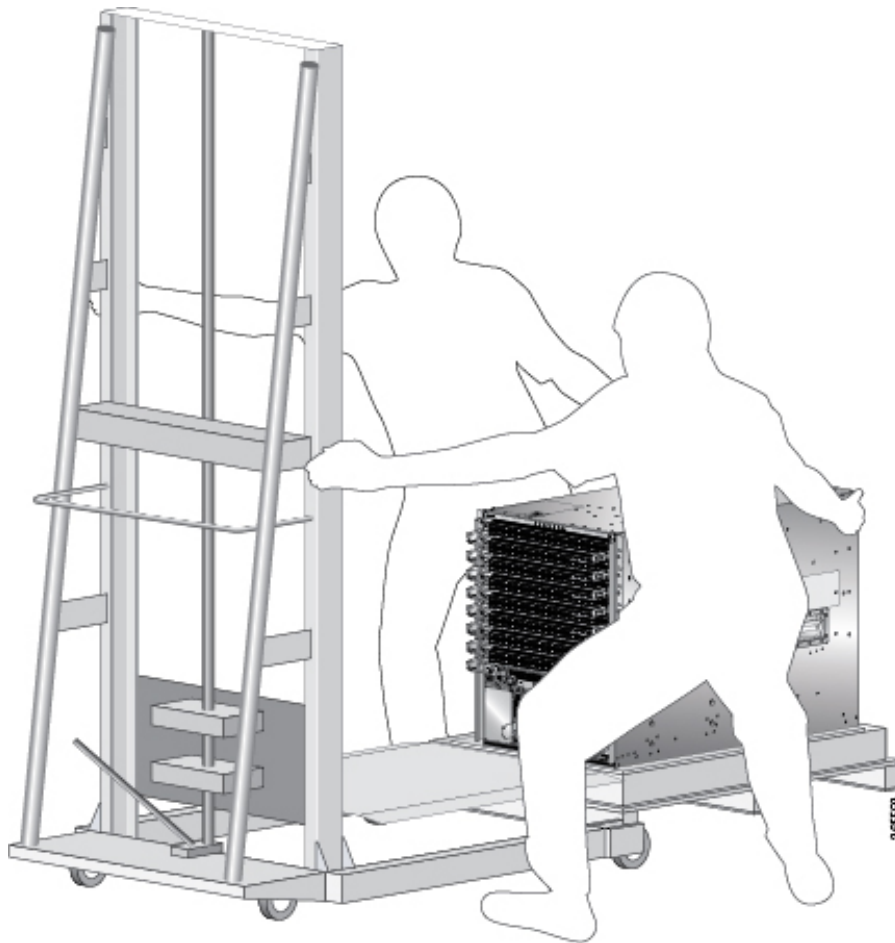

- Step 4** Using two people; lift the box straight up over the chassis.
- Step 5** Leave the chassis on the pallet until you are ready to move and install the chassis in a rack.

What to do next

After moving the chassis to the room or area where you will install it, begin the procedure to mount the chassis into the rack.

(Optional) Install the Rear Chassis Brackets

Before you begin

This procedure is required only to install door kit, which is optional.

- Step 1** To install the chassis on a 4-post 635 mm rack, attach the bracket as follows:
- a) Align the side bracket so that it is flush with the top of the chassis. See the figure below-

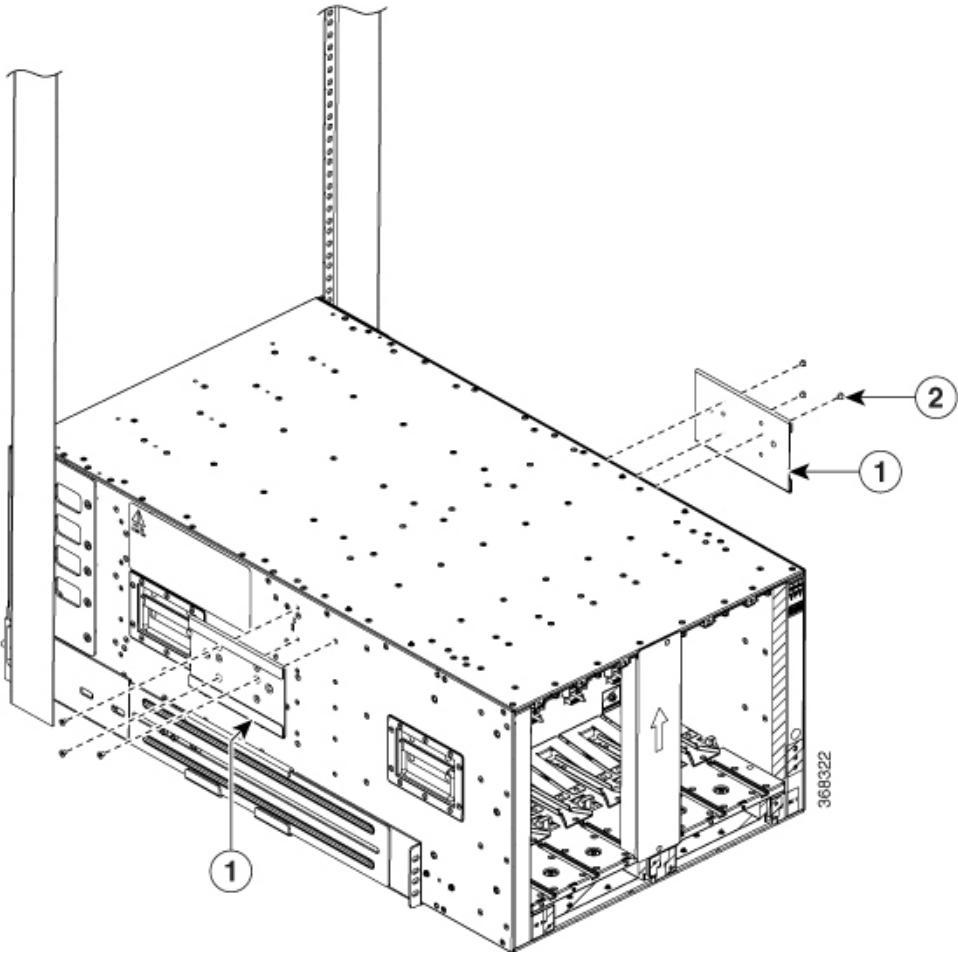

1	Side brackets	2	Screws
---	---------------	---	--------

Note The side brackets are not part of the rack mount kit. If you want to adhere to NEBS compliance, you must install the side brackets that are orderable as part of NEBS door kit.

- b) Use 6 M4 screws with 12 in-lbs (1.4 N-m) to attach the side bracket to the chassis.
- c) Repeat a and b on the other side of the chassis.
- d) Slide the rack-mount bracket through the side bracket.

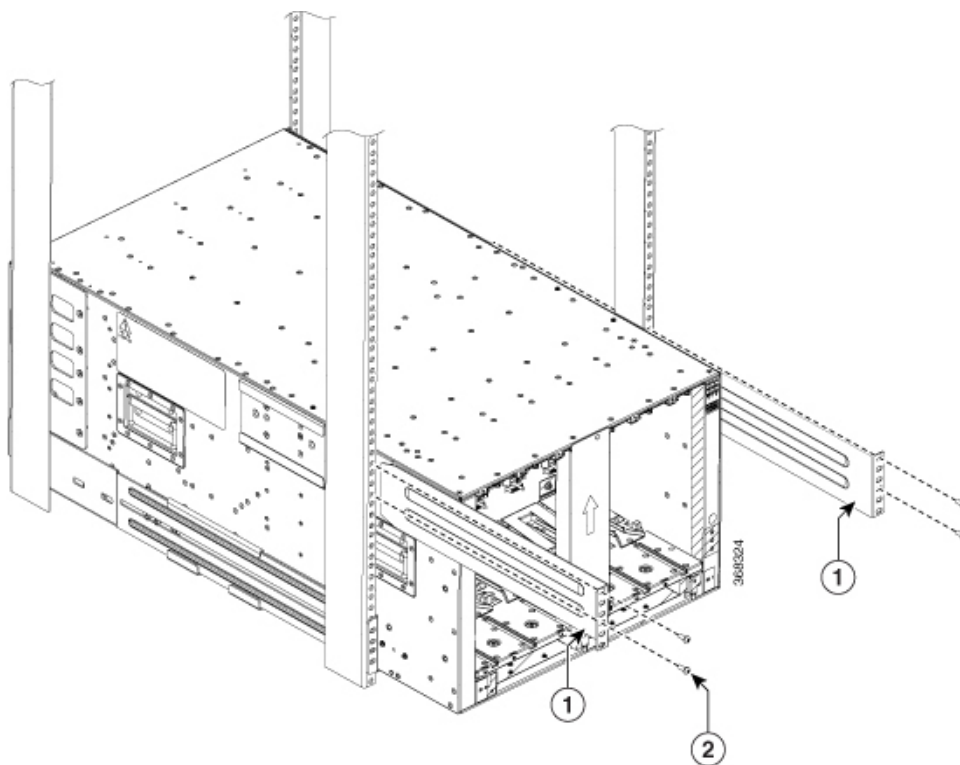

1	Rack mount brackets	2	Screws
---	---------------------	---	--------

- e) Use 4 M6 x 19 mm (or 12-24 x 3/4 in.) Phillips screws tighten each screw to (4.5 N-m) 40 in-lbs of torque to attach the bracket to the chassis.
- f) Repeat d through e on the other side of the chassis.

Step 2

To install the chassis on a 4-post 780 mm rack, attach the bracket as follows:

- a) Align the side bracket so that it is flush with the top of the chassis. See the figure below-

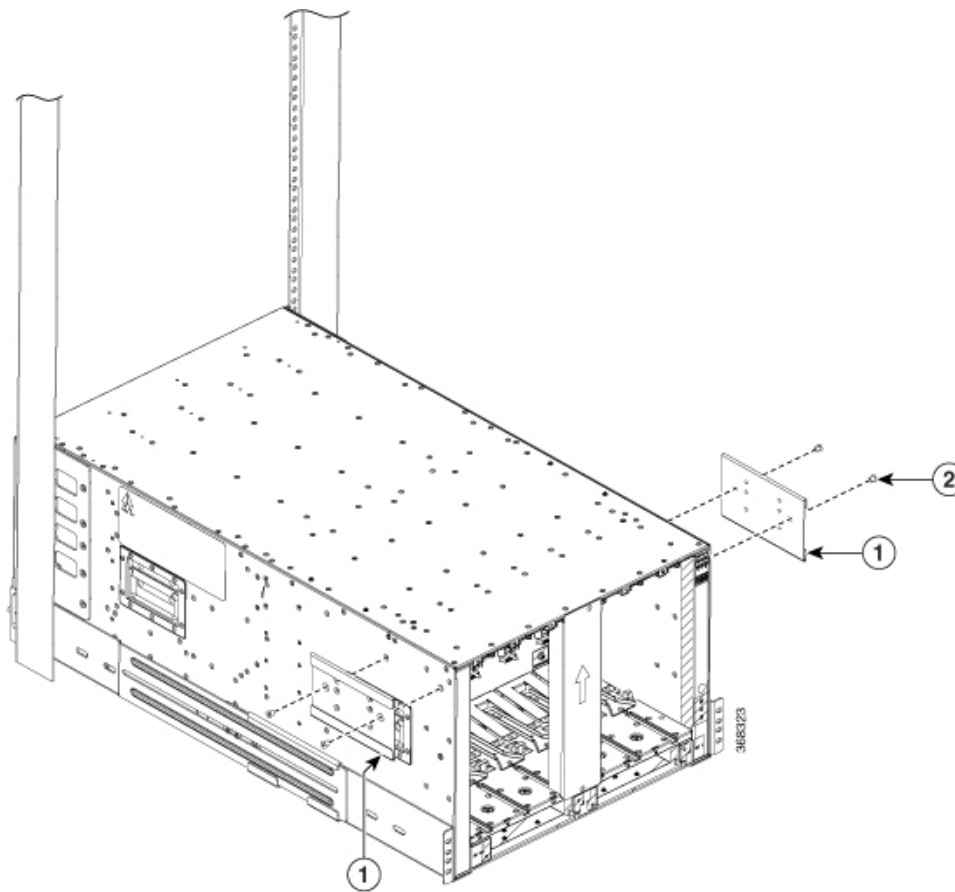
(Optional) Install the Rear Chassis Brackets

1	Side brackets	2	Screws
---	---------------	---	--------

- b) Use 4 M6 screws with (4.5 N-m) 40 in-lbs of torque to attach the side bracket to the chassis.
- c) Repeat a and b on the other side of the chassis.
- d) Slide the rack mount bracket through the side bracket.

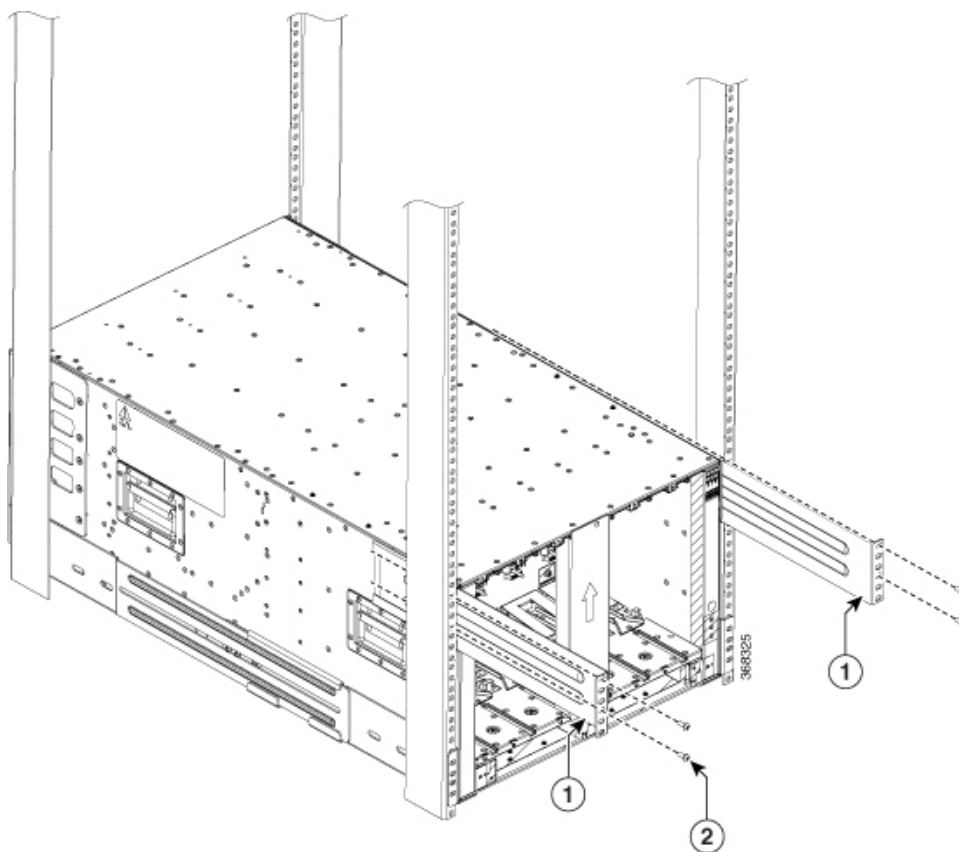

1	Rack mount brackets	2	Screws
---	---------------------	---	--------

- e) Use 4 M6 x 19 mm (or 12-24 x 3/4 in.) Phillips screws tighten each screw to (4.5 N-m) 40 in-lbs of torque to attach the bracket to the chassis.
- f) Repeat d and e on the other side of the chassis.

What to do next

After installing the rear chassis brackets, begin the procedure to mount the chassis into the rack.

Mount Chassis Into the Rack

To accommodate equipment racks with different mounting hole patterns, the chassis mounting brackets have groups of screw holes on either side. The mounting holes in the chassis mounting brackets are spaced so that one mounting hole in each hole group aligns with a corresponding hole in the equipment rack or the optional center-mount bracket. By using the corresponding mounting hole (in the same hole group) on the opposite side of the chassis, you can level the chassis in the rack.

If you need to make the chassis as light as possible for moving, remove the following modules and place them where their connectors will not be damaged:

- Power supplies—For each power supply, press and hold the eject lever, and use the handle on the front of the power supply to pull the power supply out of the chassis.
- Fan trays—Unscrew the four captive screws, and use the two handles on the fan tray to pull the fan tray out of the chassis.
- Fabric Cards—For each fabric card, keep your face at least 12 inches (30 cm) away from the modules, unscrew the screws on the center of each of the two handles on the fabric card, rotate both levers away from the front of the module, and then use the levers to pull the module out of the chassis.

As an example of a suitable lifting device, the following figure shows a scissor lift raising the chassis.



Note To lift the chassis, use a mechanical lift. Do not use the handles on the side of the chassis. Use the side handles for only repositioning the chassis after it is already on the mechanical lift or in the rack or cabinet.

Before you begin

Make sure that the rack is level and bolted to the floor.

Step 1 Load the chassis onto a mechanical lift as follows:

- a) Position the mechanical lift next to the shipping pallet that holds the chassis.
- b) Elevate the lift platform to the level of the bottom of the chassis (or no more than 1/4 inch [0.635 cm] below the bottom of the chassis).
- c) Use at least two persons to slide the chassis fully onto the lift so that the side of the chassis touches or is close to the vertical rails on the lift. Make sure that the front and rear of the chassis are unobstructed so you can easily push the chassis into the rack.

Step 2 Using your mechanical lift, raise the chassis to the height of the rack's horizontal mounting rails. Elevate the lift platform to the level of the bottom of the chassis (or no more than 1/4 inch [0.635cm] below the bottom of the chassis).

Figure 24: Example - Use Scissor Lift to Position Chassis Rack

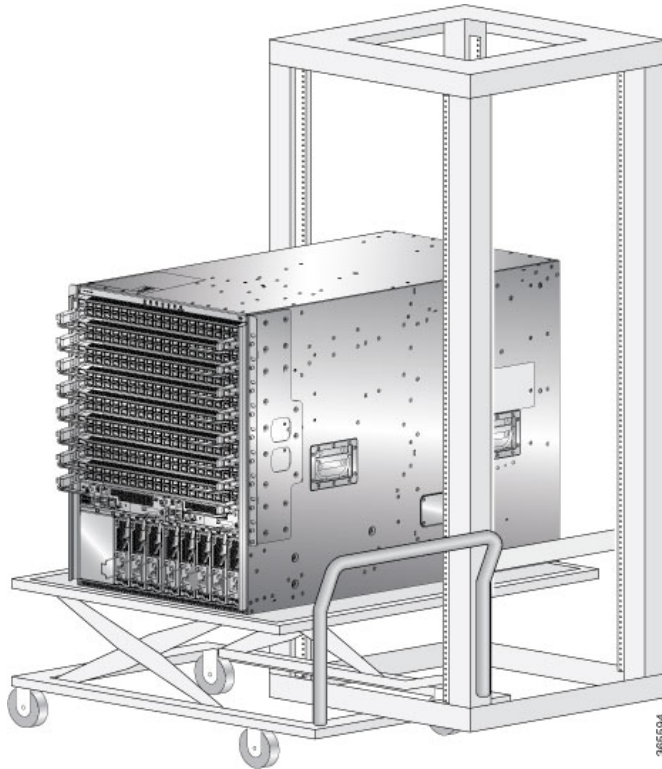

Step 3 Push the chassis halfway onto the rack or cabinet.

Use at least two persons to push the chassis onto the bottom-support rails and one person to guide the chassis down the center of the rails. Push the lower half of the front side of the chassis so that the back side enters the rack first, and push until the chassis is halfway onto the rack (see the following figure). Ensure that the chassis does not get caught on any of the expansion edges of the bottom-support rail.

Figure 25: Move Chassis onto a Rack

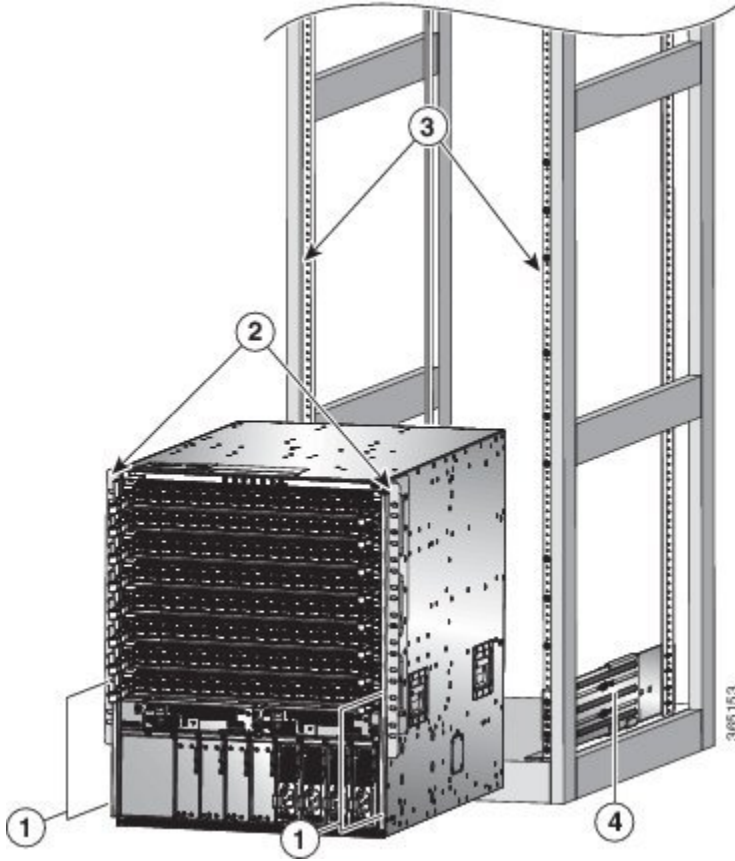

1	Push the sides of the lower half of the front side of the chassis.	3	Rack vertical mounting rails on the rack.
2	Chassis mounting brackets.	4	Bottom-support rails.

Tip To adjust the placement of the chassis on the bottom-support rails, you can use the chassis handles (see Callout 1 in the figures).

Step 4 Push the chassis all the way onto the rack so that the vertical mounting brackets on the front of the chassis come in contact with the vertical mounting rails on the rack.

Step 5 Use four M6 x 19 mm or 24 x 3/4-inch screws to attach each of the two chassis vertical mounting brackets to the two rack vertical mounting rails (total of eight screws). See Callout 2 in the figures.

Figure 26: Attach NCS 5504 Chassis to Rack

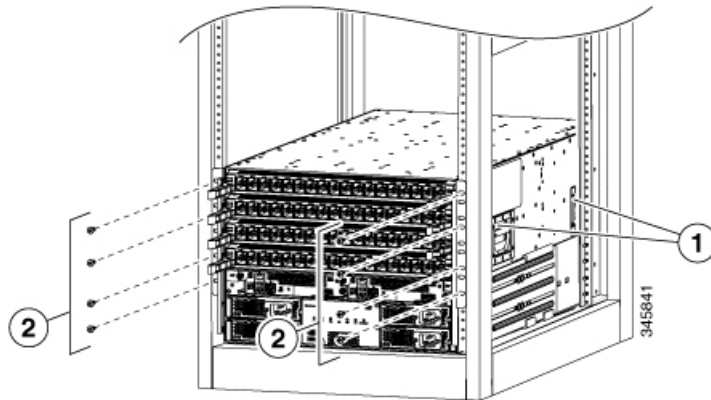

Figure 27: Attach NCS 5508 Chassis to Rack

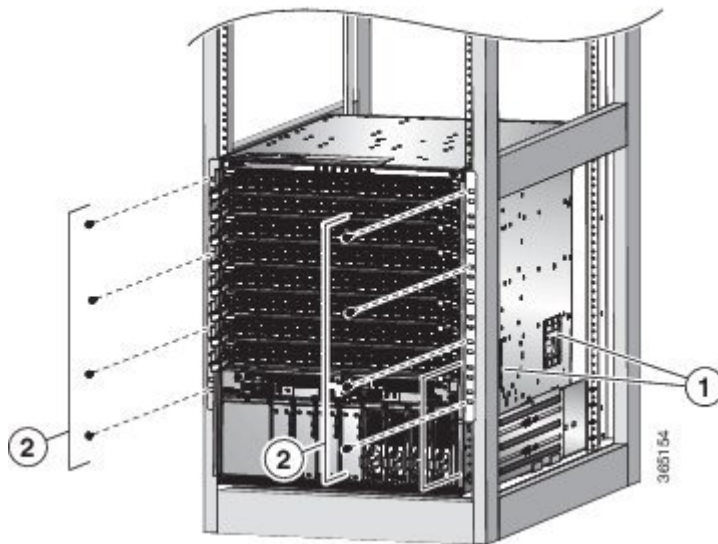
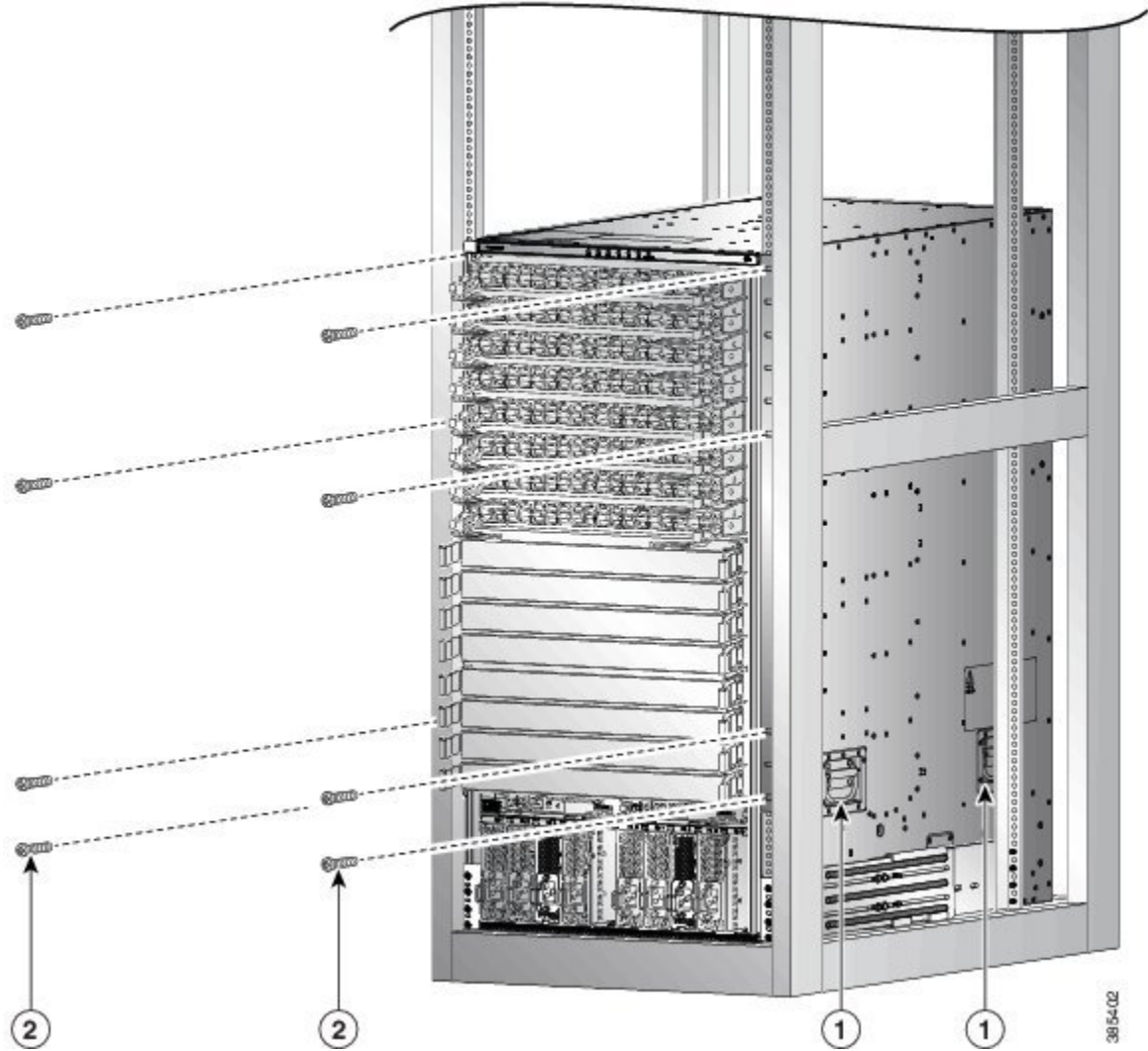

Figure 28: Attach NCS 5516 Chassis to Rack



1	Handles used to adjust chassis placement	2	Four M6 x 19 mm or 10-24 x 3/4 in. Phillips screws used to attach each side bracket to a front mounting rail (use a total of eight screws)
---	--	---	--

What to do next

After you have secured the chassis to the rack, you can connect the chassis to the data center ground.

To install the air filter or door kit, which is optional (see the [\(Optional\) Install Air Filter, Cable Management Bracket, or Door Kit on a Chassis](#) , on page 71 section).

(Optional) Install Air Filter, Cable Management Bracket, or Door Kit on a Chassis

Before you begin

The chassis must be installed and secured to the rack.

Required tools and equipment:

- Phillips screwdriver with torque capability (customer supplied)
- The following frames and screws (shipped with the optional door kit)
 - Two side brush filter frames (left and right)
 - One top hood frame
 - One lower hood frame
 - Door with filter
 - Ground Strap



Note The Door kit (optional) also contains the air filter. The door kit can be ordered separately.

Table 18: Door and Screws Required for Installation

Door/Screws	NCS 5504	NCS 5508	NCS 5516
Door Kit PID	NCS-5504-DOOR=	NCS-5508-DOOR=	NCS-5516-DOOR=
M4x12 Flat Head, Phillip Screw	12	30	42
M3x12 Flat Head, Phillip Screw	18	20	28
M3x12 PAN Head, Phillip Screw	-	3	6
M3x8 PAN Head, Phillip Screw	3	-	-
M4x8 Flat Head, Phillip Screw	4	-	-



Note The cable management brackets (optional), also referred to as side filter frames can be ordered separately. To install the cable management brackets follow the steps (Step 1 and Step 2) in this procedure, “[\(Optional\) Install Air Filter, Cable Management Bracket, or Door Kit on a Chassis](#)”. The PIDs for the cable management brackets are:

- NCS-5504-CAB-MGMT=
 - NCS-5508-CAB-MGMT=
 - NCS-5516-CAB-MGMT=
-

To replace an existing air filter, you must order the air filter separately. The PIDs for the air filters are:

- NCS-5504-FLTR=
 - NCS-5508-FLTR=
 - NCS-5516-FLTR=
-

Step 1

Attach the two side extension brackets to the chassis as follows:

- a) Remove the screws from the bottom support rails. Save the screws for re-installation.
- b) Position one of the side extension brackets on the vertical mounting bracket and the bottom support rails so that the two screw holes are aligned.
- c) Secure the extension bracket to the chassis vertical mounting bracket with M6 x 19 mm (or 12-24 X ¾ inch screws), pan-head, Phillips screws. Note that these are the screws you removed earlier in Step a. Tighten each screw to 40 in-lb (4.5 N·m) of torque. The number of screws can vary based on the chassis.
- d) Repeat Steps 1a - 1c to attach the other side of the extension bracket to the vertical mounting bracket on the opposite side of the chassis.

Figure 29: Attach Two Side Extension Bracket on NCS 5504 Chassis

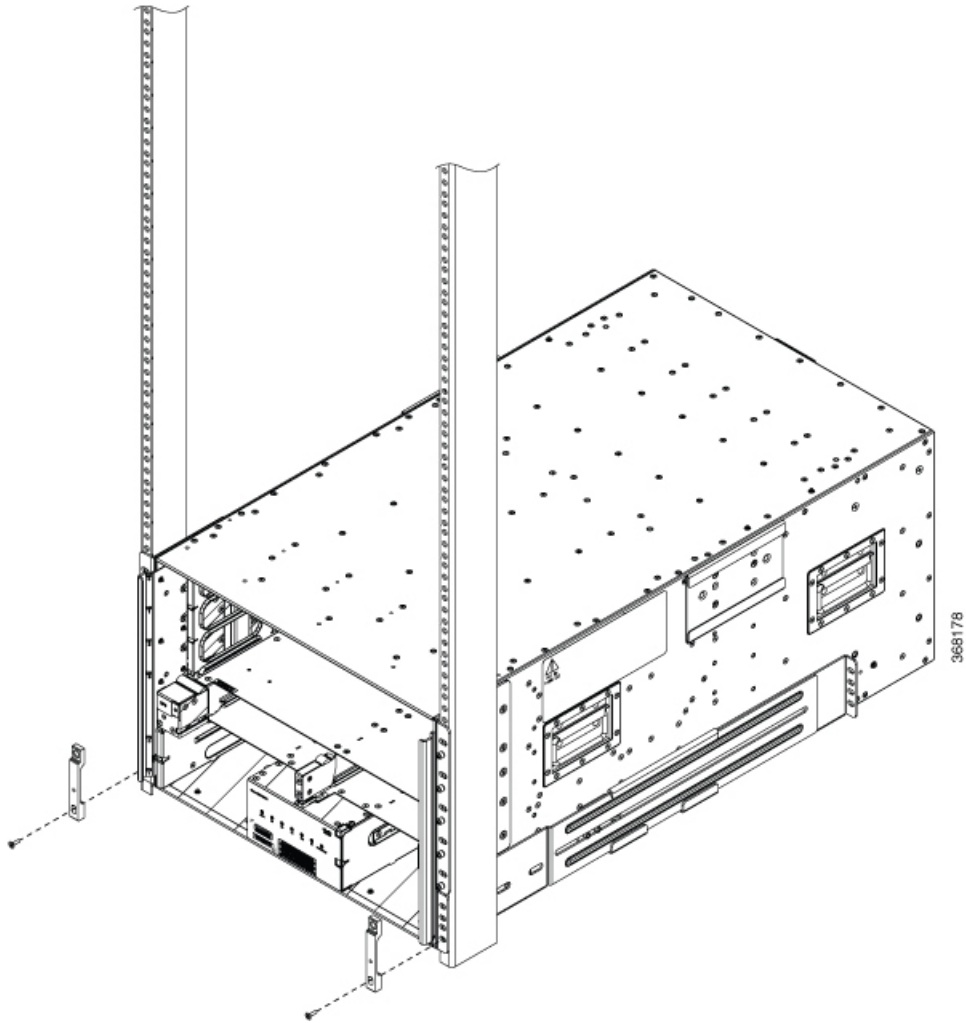

Figure 30: Attach Two Side Extension Bracket on NCS 5508 Chassis

Figure 31: Attach Two Side Extension Bracket on NCS 5516 Chassis



Step 2

Attach the two side filter frame assemblies or the cable management brackets to the chassis as follows:

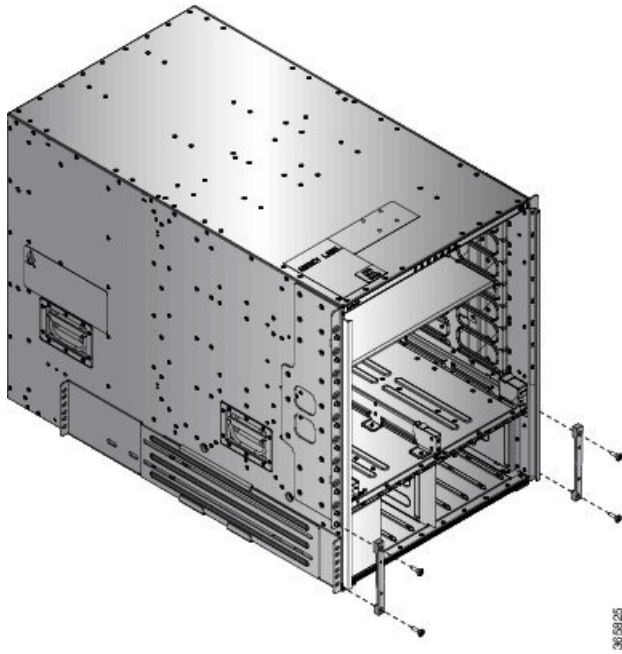
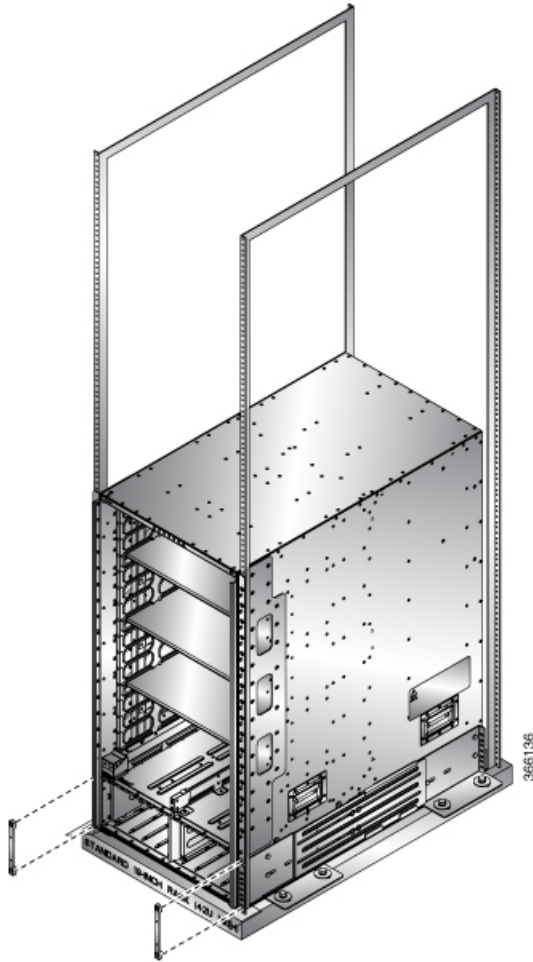
- a) Position one of the side frame assemblies on the vertical mounting bracket attached to one side of the front of the chassis.

For NCS 5504: Ensure that the upper most 4 screw holes in the assembly align with the screw holes in 4 visible standoffs on the mounting bracket.

Figure 32: Attach Side Filter Assembly or Cable Management Brackets to NCS 5504 Chassis

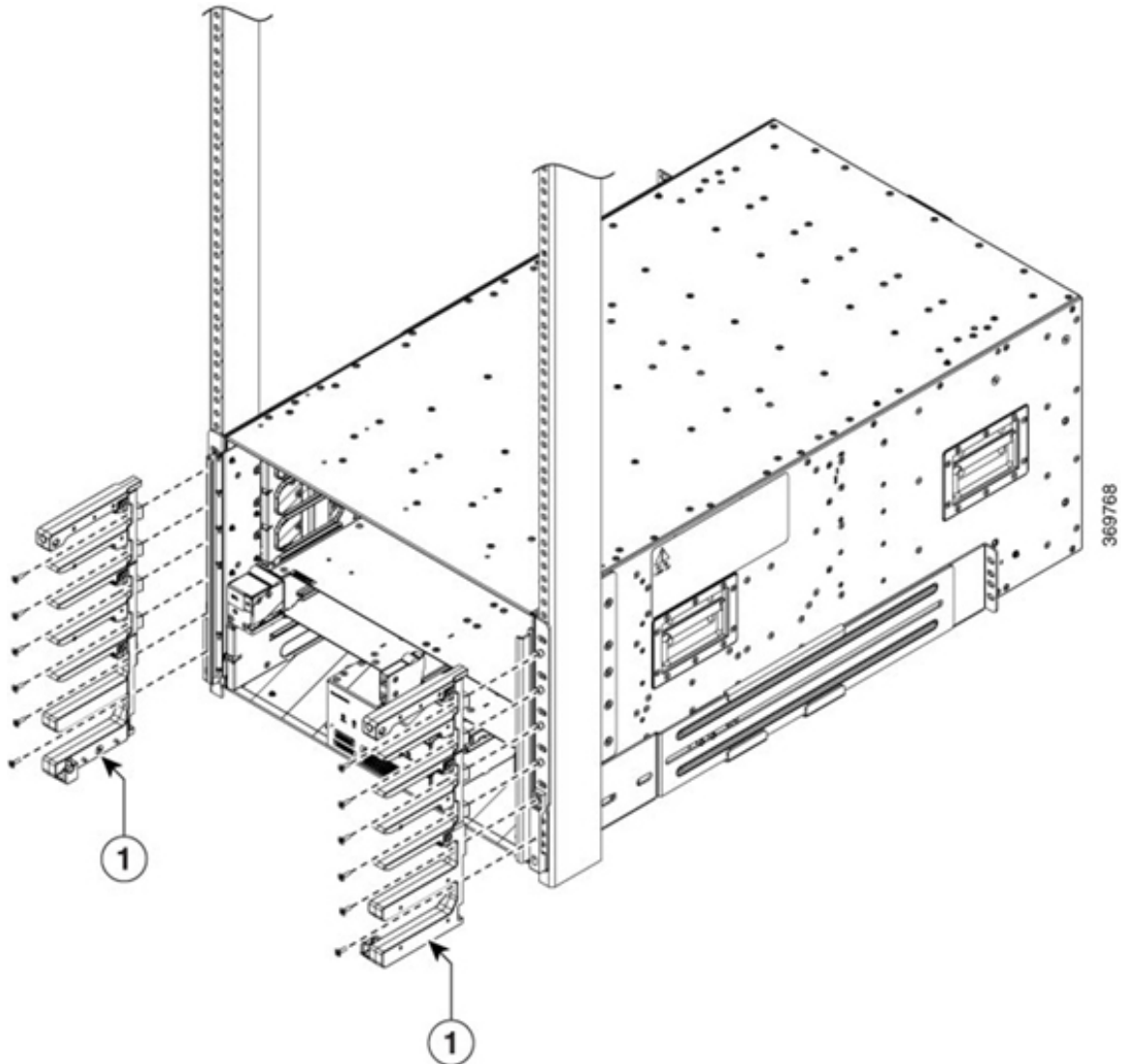

For NCS 5508: Ensure that the 5 screw holes in the assembly align with the screw holes in five standoffs on the mounting bracket.

Figure 33: Attach Side Filter Assembly or Cable Management Brackets to NCS 5508 Chassis

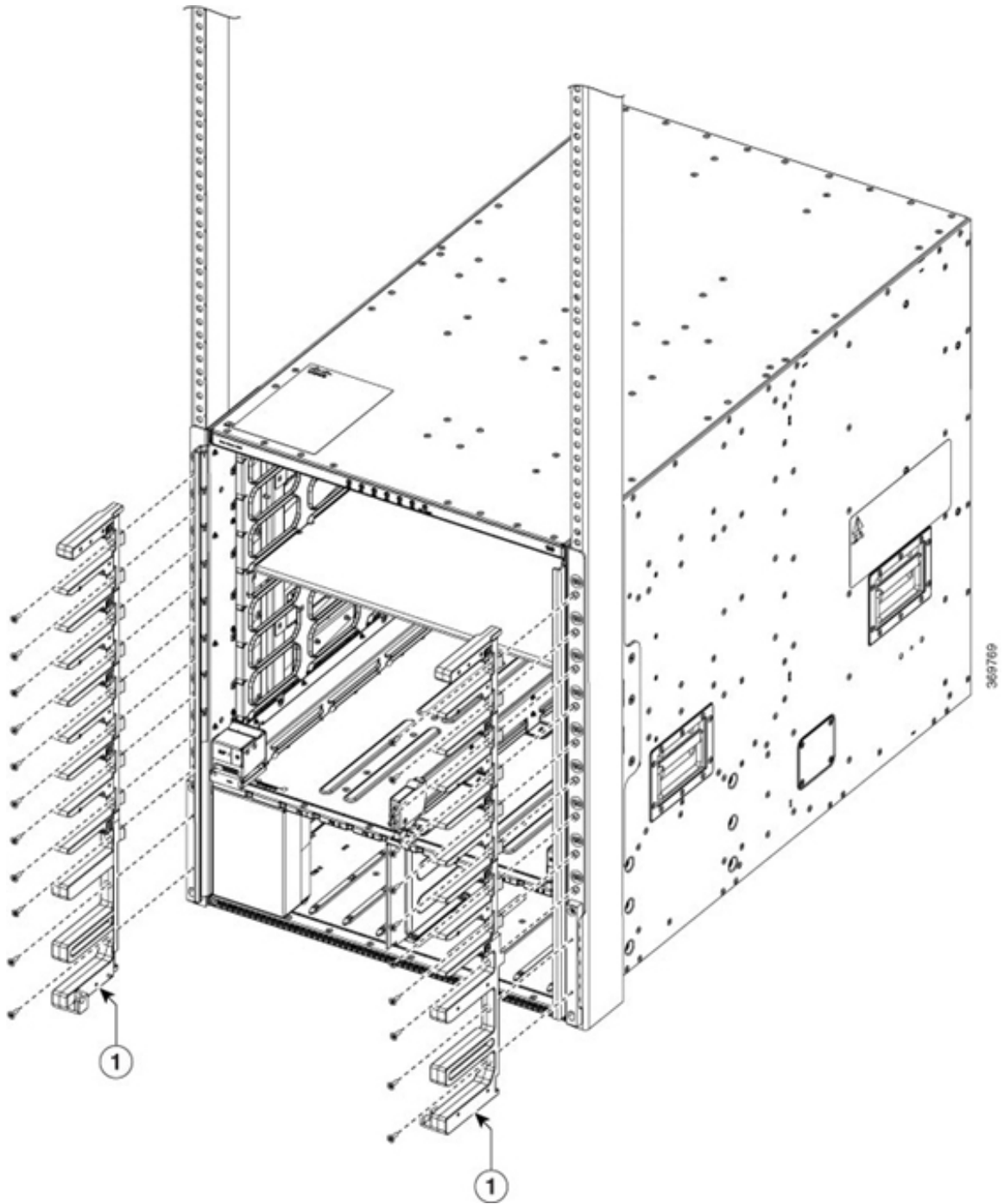

For NCS 5516: Ensure that the 17 screw holes in the assembly align with the screw holes in 17 standoffs on the mounting bracket.

Figure 34: Attach Side Filter Assembly or Cable Management Brackets to NCS 5516 Chassis

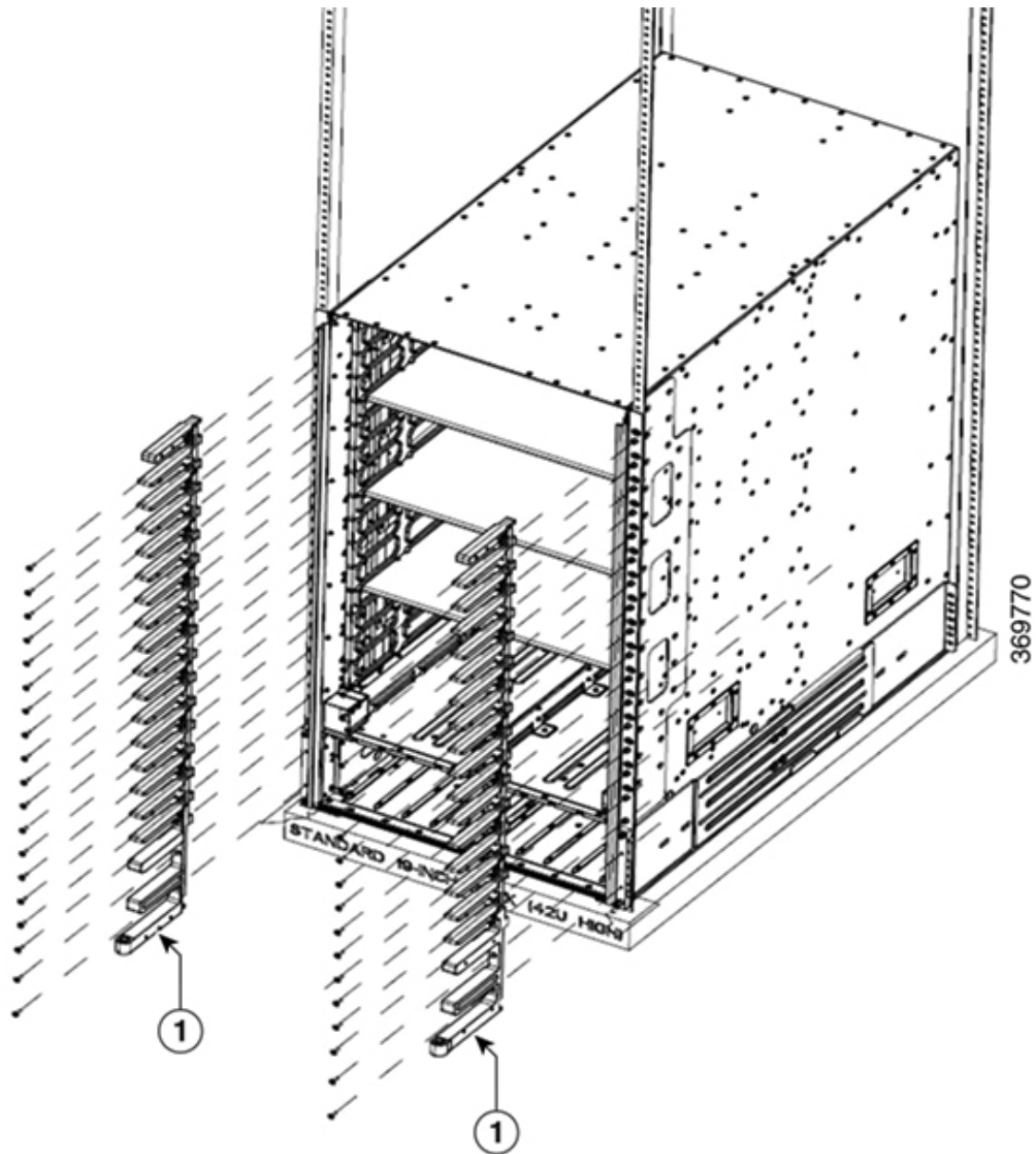

1	Cable Management Brackets or Side Filter Frames
---	---

- b) Secure the upper portion of the assembly to the chassis vertical mounting bracket.

For NCS 5504: Use 12 M4 x 12 mm, flat-head, Phillips screws.

For NCS 5508: Use 5 M4 x 12 mm, flat-head, Phillips screws.

For NCS 5516: Use 17 M4 x 12 mm, flat-head, Phillips screws.

Tighten each screw to 11.5 to 15 in-lb (1.3 to 1.7 N·m) of torque.

- c) Secure the bottom portion of the assembly to the chassis using two M4 x 12 MM flat-head Phillips screws in each of the two angled brackets on the assembly. Tighten each screw to 11.5 to 15 in-lb (1.3 to 1.7 N·m) of torque.
- d) Repeat Steps 2a and 2c to attach the other side filter frame assembly to the mounting bracket on the opposite side of the chassis.

Step 3

Attach the two air filters to the side filter frames as follows:

- a) Remove an air filter from its packaging and position it on the side frames.

NCS 5504: Ensure that its 9 holes align with 9 screw holes in the side brush filter frame.

NCS 5508: Ensure that its 10 holes align with 10 screw holes in the side brush filter frame.

NCS 5516: Ensure that its 14 holes align with 14 screw holes in the side brush filter frame.

- b) Fasten the air filter to the side brush filter assembly.

NCS 5504: Use 9 M3 x 12 mm screws.

NCS 5508: Use 10 M3 x 12 mm screws.

NCS 5516: Use 14 M3 x 12 mm screws.

- c) Tighten the M3 screws to 5 to 7 in-lb (0.56 to 0.79 N.m) of torque.

Figure 35: Attach Side Filter Assembly to NCS 5504 Chassis

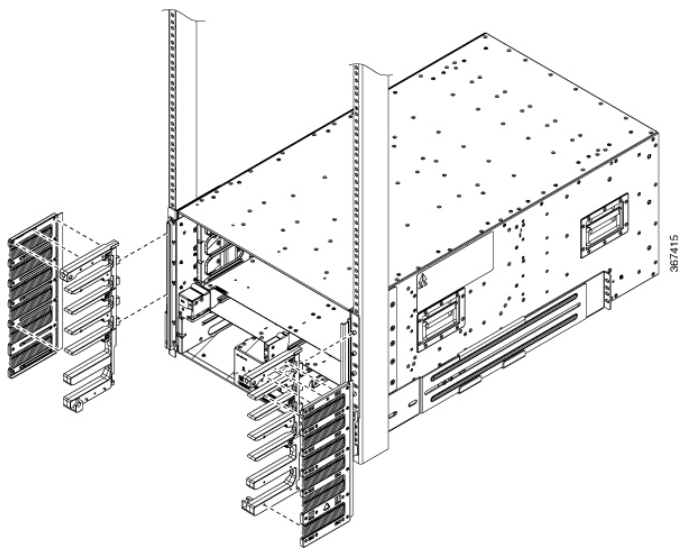

Figure 36: Attach Side Filter Assembly to NCS 5508 Chassis

Figure 37: Attach Side Filter Assembly to NCS 5516 Chassis



d) Repeat Steps 3a through 3c to attach the other air filter to the side filter assembly on the other side of the chassis.

Step 4 NCS 5504 and NCS 5508: Attach the bottom plate and top hood to the two side assemblies as follows:

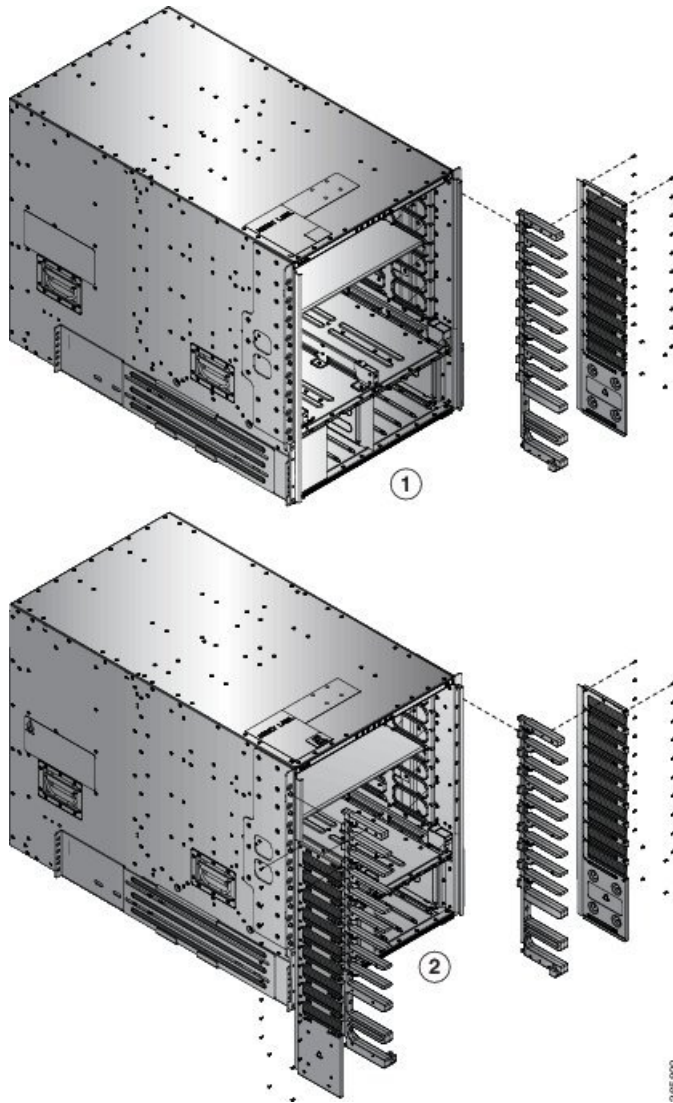
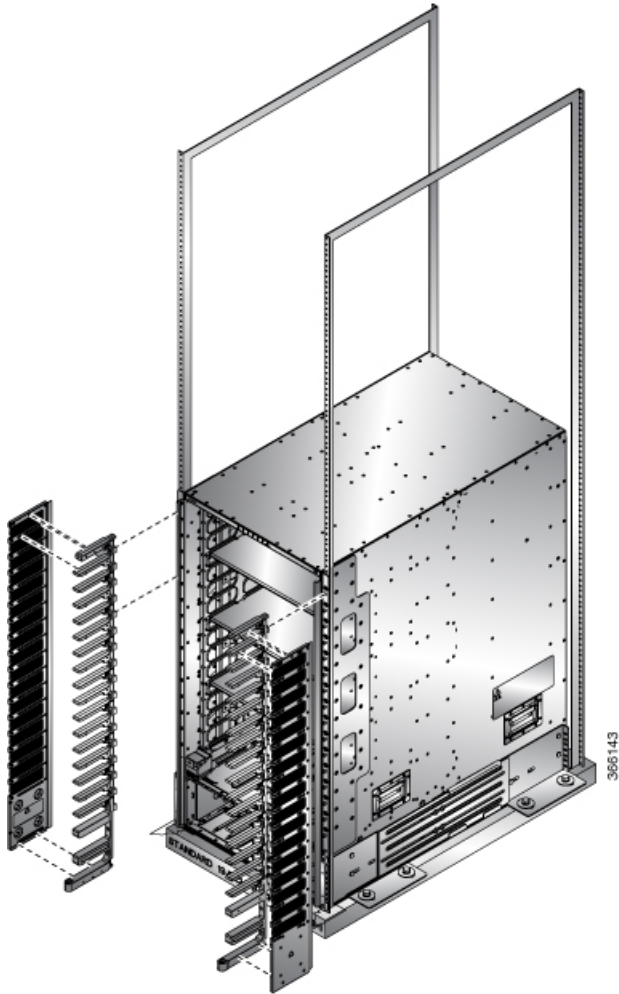
Note For NCS 5504, use 2 M3 x 8 mm pan head screws to secure the bottom plate.

Figure 38: Attach Bottom Plate to NCS 5504 Side Brush Filter Kit

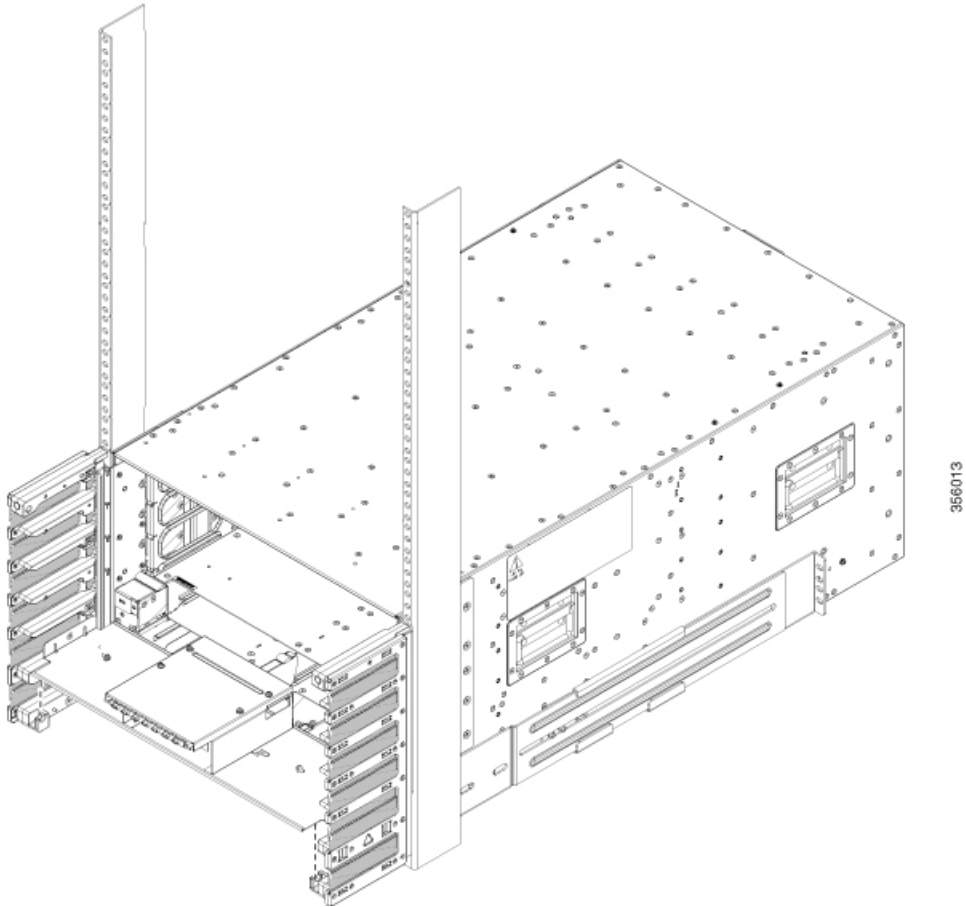

Note For NCS 5504, use 4 M4 x 8 mm flat head screws to secure the top hood.

Figure 39: Attach Top Hood to NCS 5504 Chassis and Side Brush Filter Kit

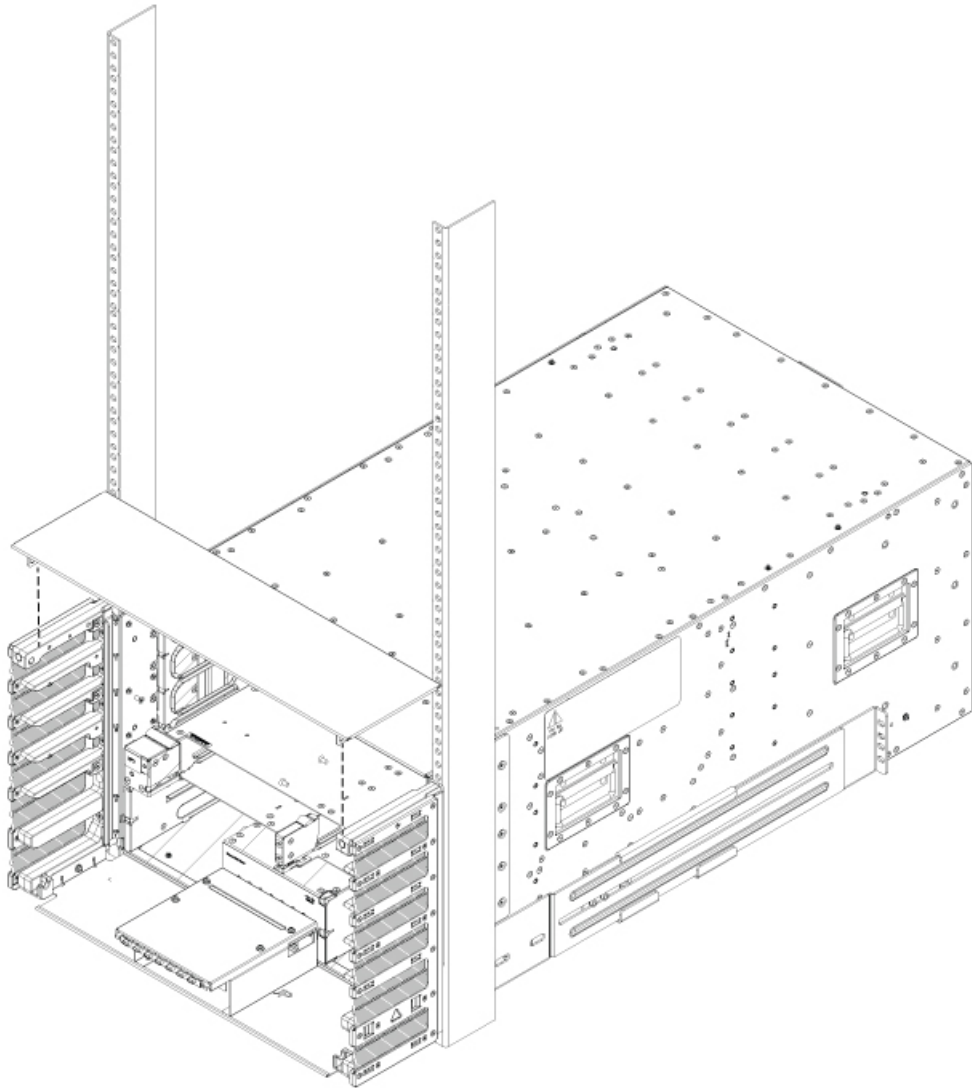

356011

Figure 40: Attach Top Hood to NCS 5508 Chassis and Side Brush Filter Kit

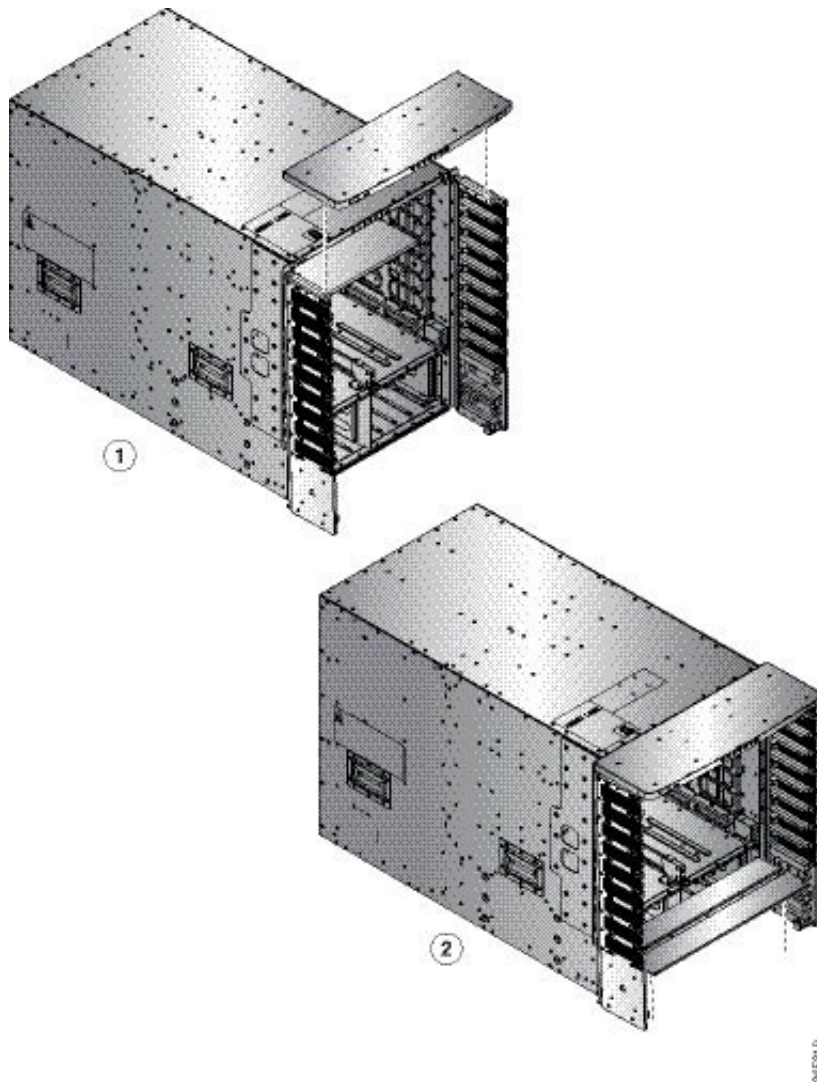

- Place the bottom plate, with its brackets pointing up, to the bottom of the two side brush filter kit assemblies.
- Place the top hood, with its brackets pointing down, on top of the two side brush filter kit assemblies.
- (Only NCS 5504) Secure the bottom plate using 2 M3 x 8 mm pan head screws and top hood using 4 M4 x 8 mm flat head screws.
- (Only NCS 5508) Secure the bottom plate and top hood to the two side assemblies by using 8 M4 x 12 mm flat-head Phillips screws (use two screws for each assembly). Tighten each screw to 11.5 to 15 in-lb (1.3 to 1.7 N·m) of torque.

Step 5 NCS 5516: Attach the top hood to the chassis and the tops of the two side brush filter kit assemblies as follows:

Figure 41: Attach Top Hood to NCS 5516 Chassis and Side Brush Filter Assemblies

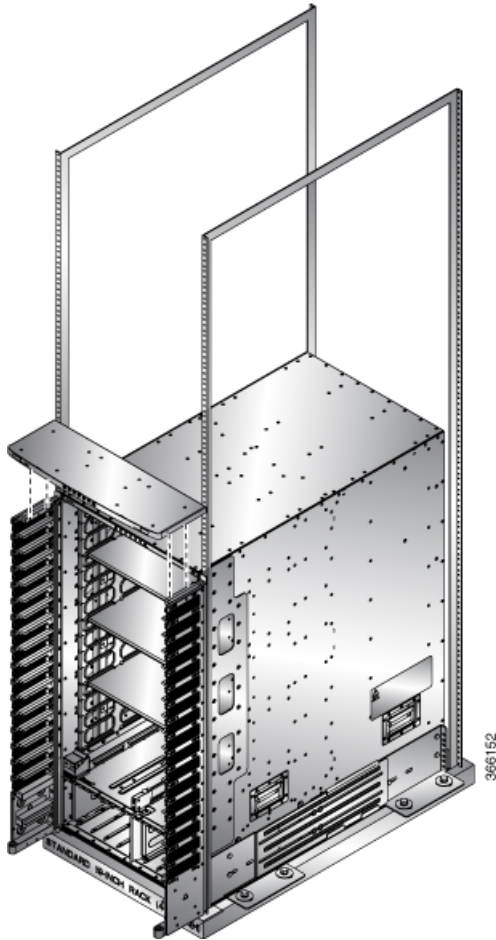

- a) Place the top hood, with its brackets pointing down, on top of the two side brush filter kit assemblies.
- b) Secure the top hood to the two side assemblies by using four M4 x 12 mm flat-head Phillips screws (use two screws for each assembly). Tighten each screw to 11.5 to 15 in-lb (1.3 to 1.7 N·m) of torque.

Step 6

Attach the divider bracket to the left and right side brush filter kit assemblies as follows:

- a) Position the divider bracket between the right and left side brush filter kit assemblies near the bottom of the chassis.
- b) Align the two slots on both sides of the bracket with the pins that stick out from the lower side brush filter kit frame and lower the bracket past the pins until the bracket stops.
- c) A screw hole on each side of the divider bracket aligns with a screw hole in each side brush filter kit assembly.
- d) Secure the divider bracket to both side brush filter kit assemblies using two M3 x 8 mm screws (one screw for each of two sides) and tightening the screws to 5 to 7 in-lb (0.56 to 0.79 N·m) of torque.

Step 7

(For NCS 5516 Only): Install the door-stop bracket on the top hood of the side brush filter kit frames by positioning the door-stop bracket to the bottom divider frame so that its two screw holes align to the two screw holes in the bottom divider. Ensure that there is a perpendicular edge facing the front. This edge stops the front doors when they are closed.

Figure 42: Install Door-Stop Bracket

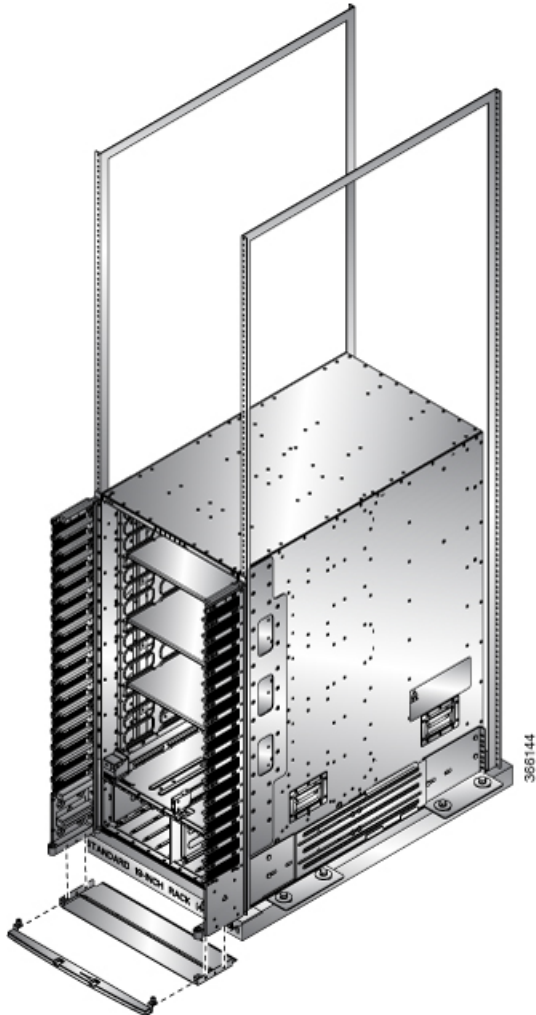

Attach Front Door to NCS 5504 and NCS 5508 Chassis

Before you begin

Before you can attach the front door to the chassis, you must attach side filter frames, bottom divider bracket to the chassis.

-
- Step 1** Place the two bars at the bottom of the front door on the two bar holders. Each bar holder is at the bottom of the side filter assembly.
- Step 2** (NCS 5504) With the door resting on the bar holders, move the top of the door towards the top hood.
- Step 3** (NCS 5508) With the door resting on the bar holders, rotate the top of the door to the top hood

The latch on the door will slide and lock in-position.

Figure 43: Attach Front Door to NCS 5504 Chassis

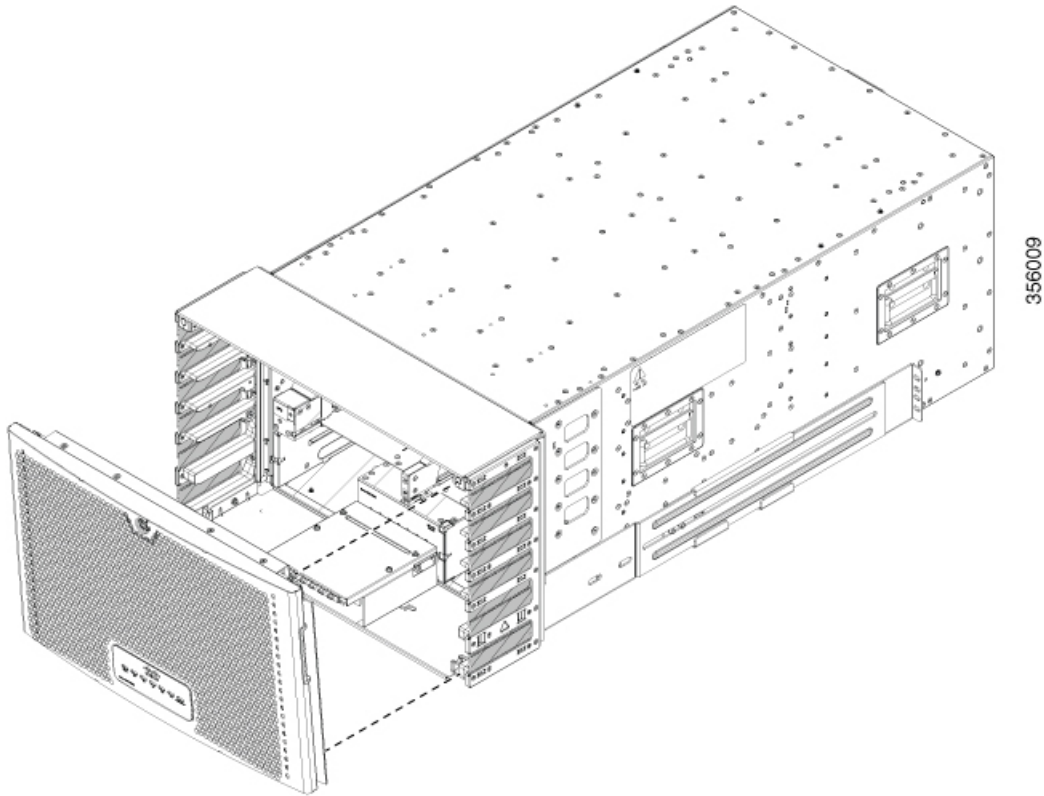
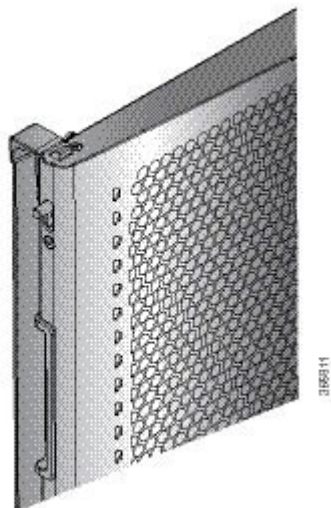

Figure 44: Attach Front Door to NCS 5508 Chassis



Attach Front Door to NCS 5516 Chassis

Step 1 On the back side (open side) of one door, pull in on two protruding spring pins so that the pins are held inside the door frame.

Figure 45: Attach Front Door to NCS 5516 Chassis

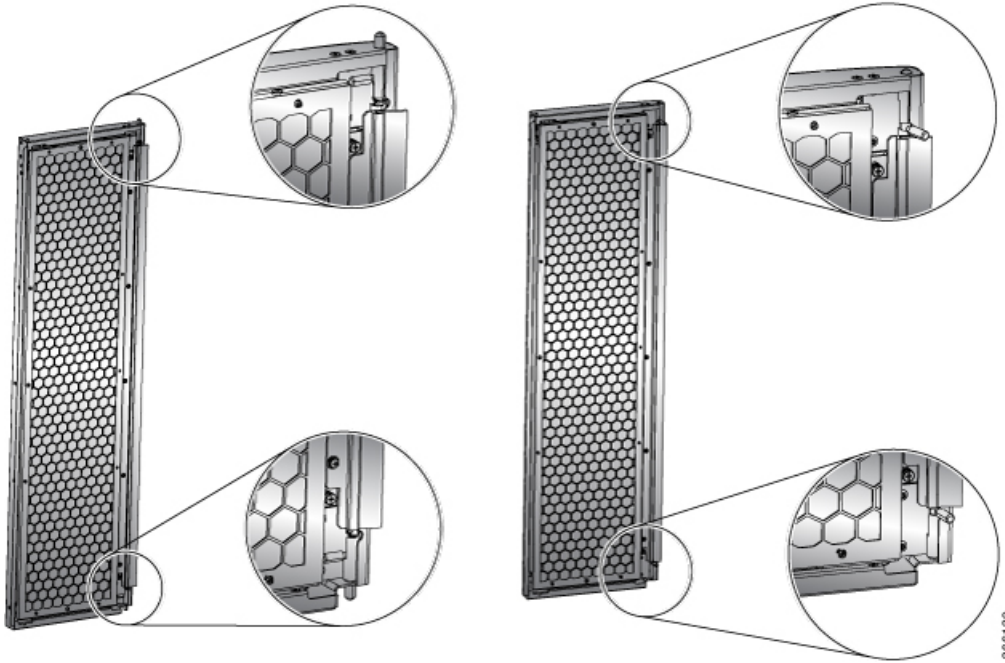

Hold these two pins in through the next step.

- Step 2** Align the spring pins to holes in the top hood and divider bracket.
- Step 3** Release the two spring pins so that they insert into the holes in the top hood and divider brackets. The door should freely swing on the spring pins.
- Step 4** Repeat Steps 1 through 3 to install the other front door.

Replace Chassis Door Foam Air Filters on the NCS 5504



Note In general, we recommend that you inspect the air filter every 3 months and replace, if necessary, every 6 months.

The front doors come with pre-installed air filters. If air filters need replacement, follow this procedure.

- Step 1** Remove existing door filter and side brush brackets as follows:
 - a) Remove the front door.

- b) Remove the side brush brackets by unscrewing the captive screws at the top of each brush bracket.
- c) Pull the foam air filter away from the snap-top alignment pins (two on the top and two on the bottom of the door).

Step 2

Install the new door filter as follows:

- a) Align the 4 alignment holes on to the filter to the 4 alignment pins on the door.

Figure 46: Align Door Filter to the Door

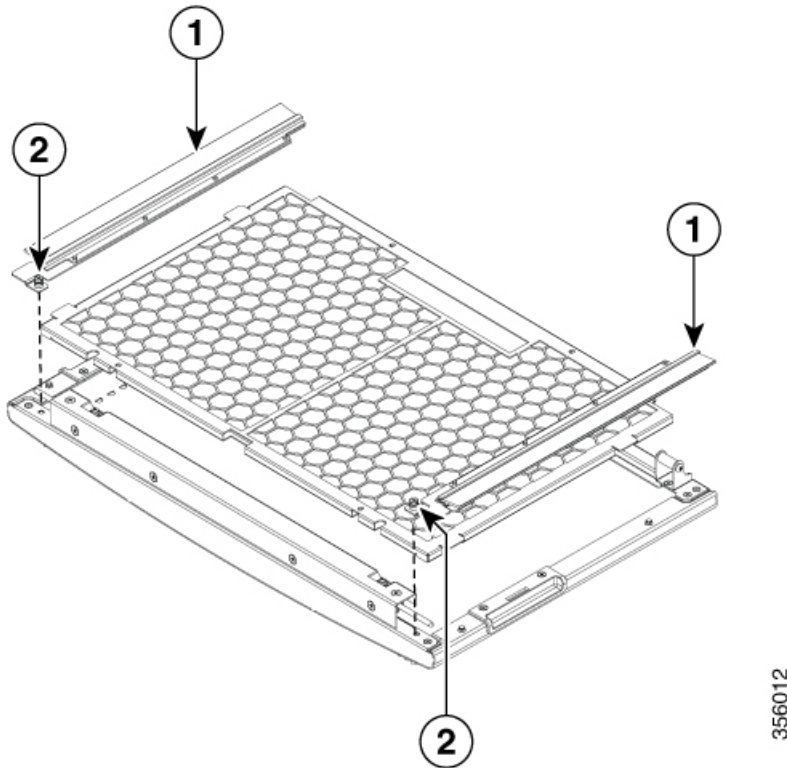

1	Side brush bracket	2	Side brush bracket screws
---	--------------------	---	---------------------------

- b) Press the filter onto the alignment pins.
- c) Install the side brush brackets and tighten the captive screws to secure the filter to the door.

What to do next

Ground the Front ID Door

Replace Chassis Door Foam Air Filters on the NCS 5508



Note In general, we recommend that you inspect the air filter every 3 months and replace, if necessary, every 6 months.

The front doors come with pre-installed air filters. If air filters need replacement, follow this procedure.

- Step 1** Remove existing door filter and side brush filters as follows:
- a) Remove the front door.
 - b) Remove the side brush filters by unscrewing the captive screws at the top of each brush filter.
 - c) Pull the foam air filter directly away from the door to clear of the snap-top alignment pins (two on the top, two on the side and two on the bottom of the door).

- Step 2** Install the new door filter as follows:
- a) Align the 4 alignment holes on to the filter to the 4 alignment studs on the door.

Figure 47: Align Door Filter to the Door

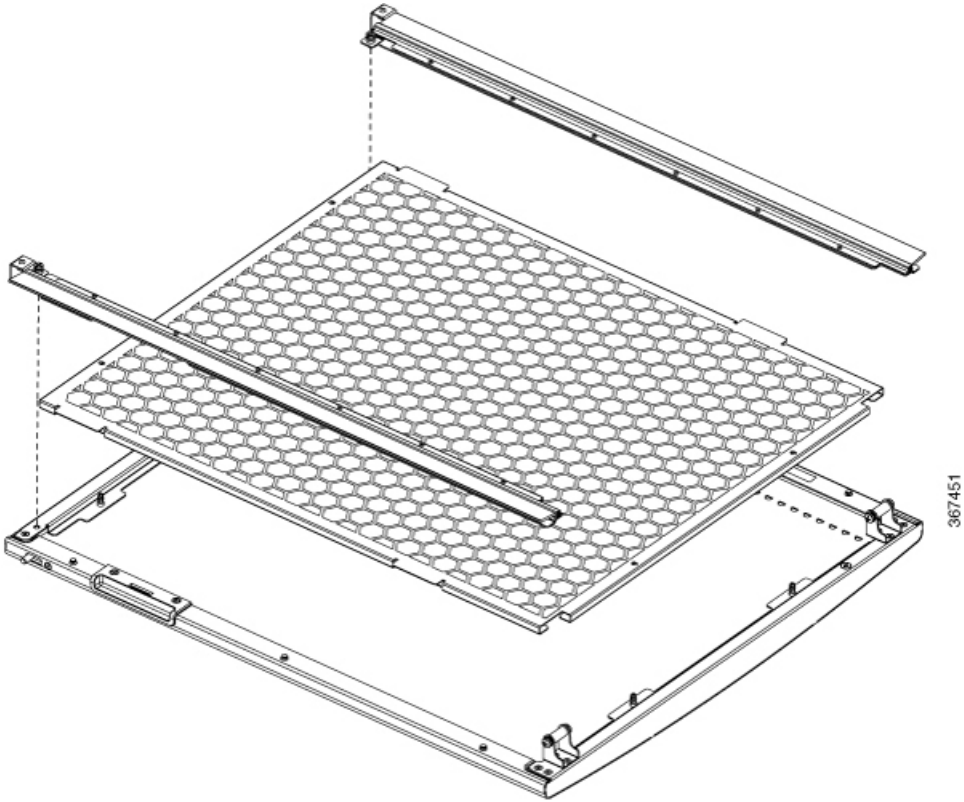

- b) Press the filter onto the alignment studs.
- c) Install the side brush filters and use 2 screws to secure the filter to the door.

Replace Chassis Door Foam Air Filters on the NCS 5516



Note In general, we recommend that you inspect the air filter every 3 months and replace, if necessary, every 6 months.

The front doors come with pre-installed air filters. If air filters need replacement, follow this procedure.

Step 1

Remove existing two door filters and two door-side filters on the two front doors as follows:

- a) Open the front doors and keep it in open position.
- b) Remove the door-side brush filter by unscrewing the captive screws on both ends of the filter.
- c) Remove the 3x screws securing the foam air filters.
- d) Pull the foam air filter directly away from the door to clear of the snap-top alignment pins (two on the top, two on the side and two on the bottom of the door).

Step 2

Install the two new door filters and two door-side filters on the two front doors as follows:

- a) Align the six alignment holes on the largest filter to six alignment studs on the open side of the door.

Figure 48: Align Door Filter to a Door

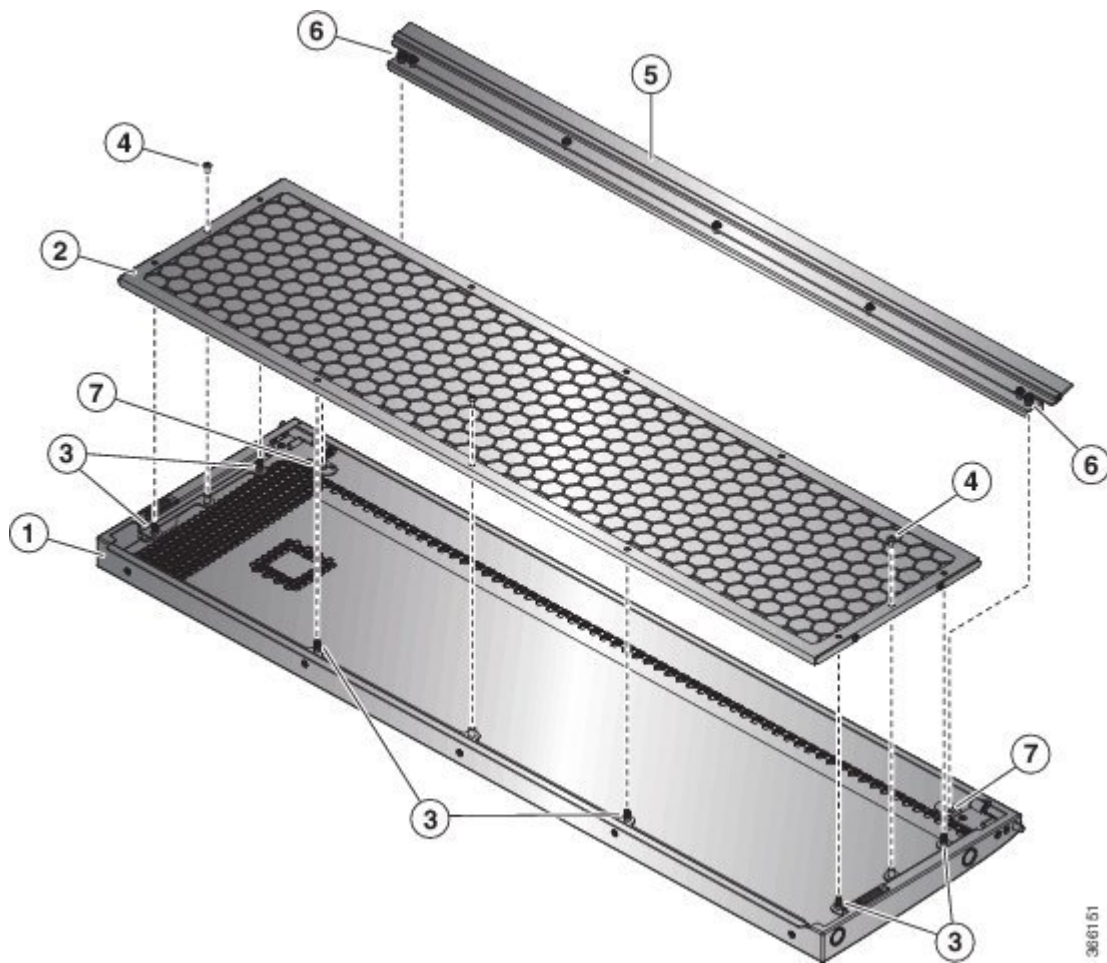

1	Front door back side facing up	2	Air filter for inside of door
3	Alignment pins (two on top, side and bottom of the door)	4	Three screws used to secure filter to the the door
5	Air filter for side of the door	6	Captive screws one on each end

7	Screw hole for captive screw on filter
---	--

b) Press the filter onto the alignment studs and use three #6-32 x 0.25” screws to secure the filter to the door.

Step 3 Repeat Steps 2a through 2b to install the air filters to the other front door.

What to do next

Ground the Front ID Door

Ground the Front ID Door



Note To comply with GR-1089, you have to bond the front ID door to the ground port on the chassis using the ground braid.

Step 1 Install the grounding cable to the right side of the front ID door.

Step 2 Apply the star ring terminal end of the grounding cable to the front ID door. Tighten the screw to 7 in-lb (0.79 N-m) of torque to provide proper bonding.

Figure 49: Ground the NCS 5504 Front ID Door

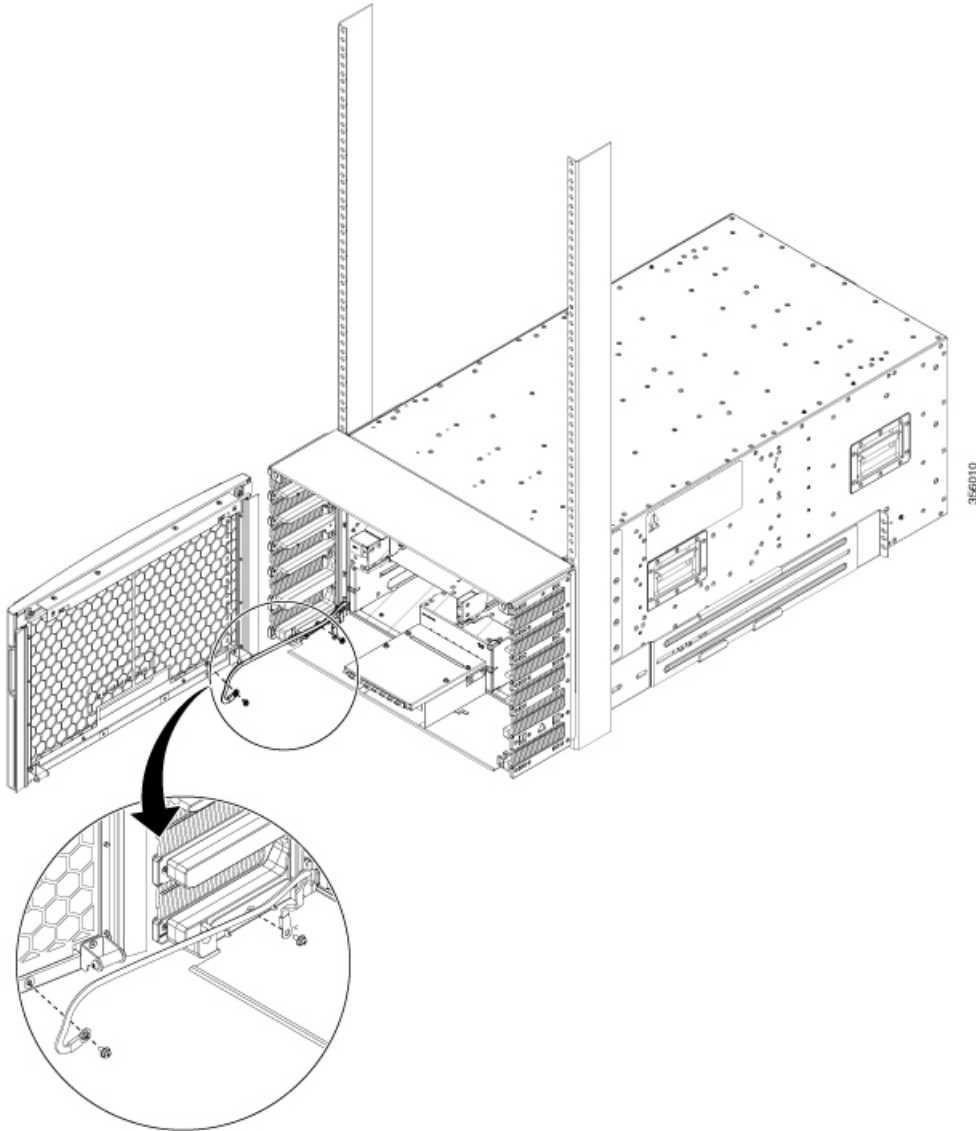

Ground the Front ID Door

Figure 50: Ground the NCS 5508 Front ID Door

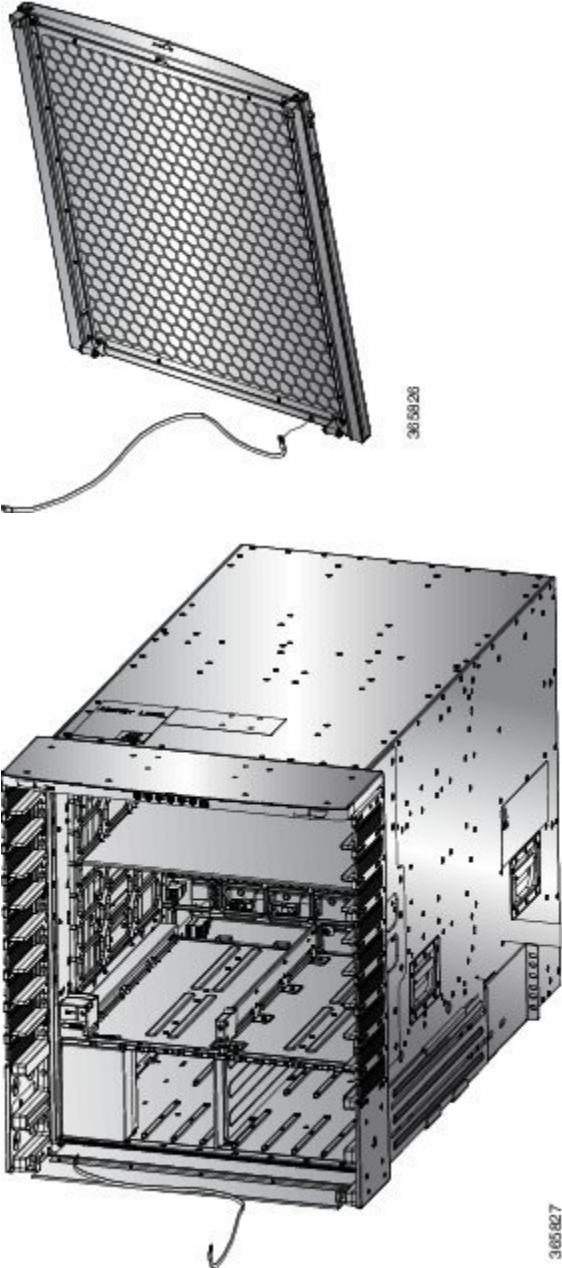
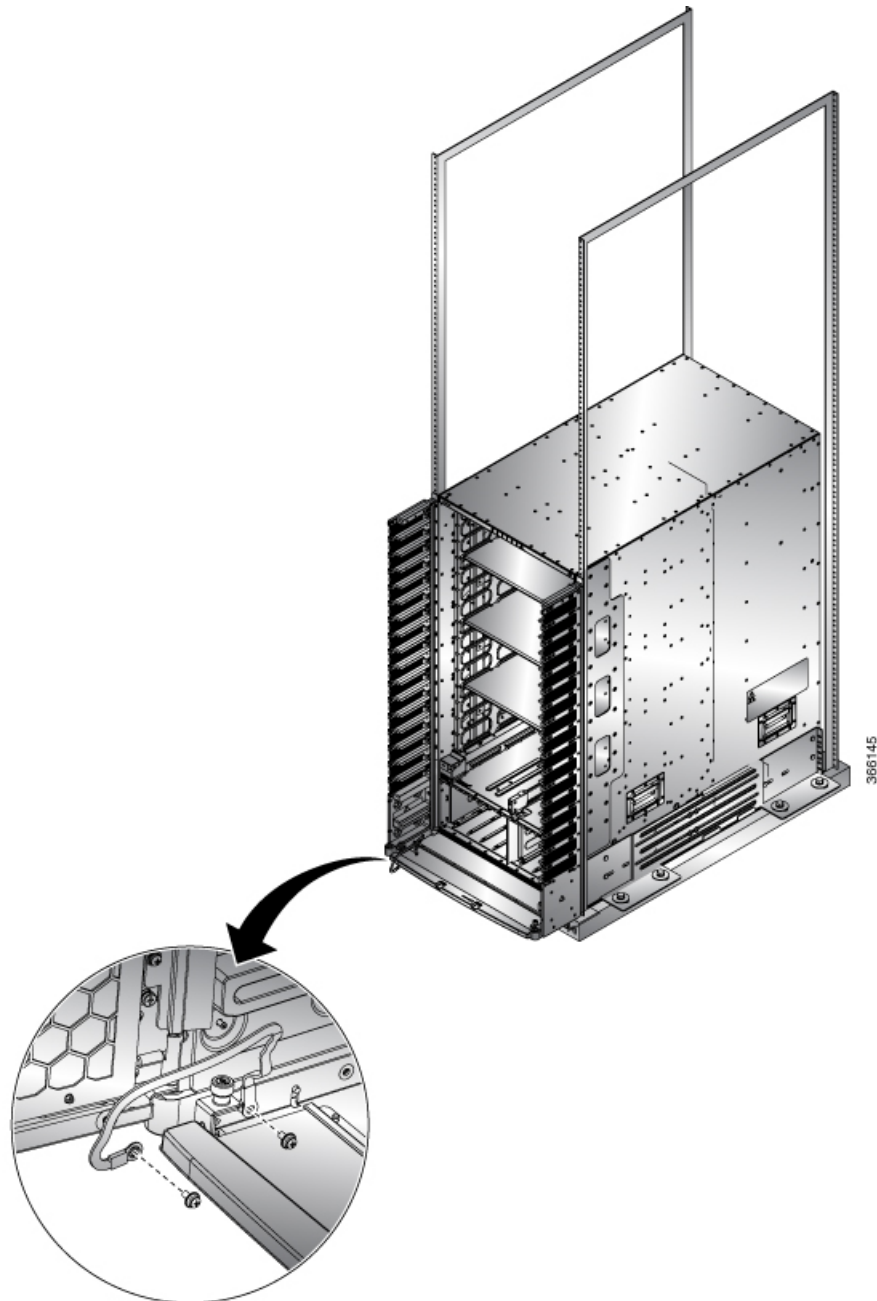

Figure 51: Ground NCS 5516 Front ID Door



- Step 3** Connect the other round terminal of the grounding cable to the ground port on the side filter bracket on either left/right side of the chassis. Tighten the M4 screw to 9 to 12 in-lb (1.01 to 1.35 N-m) of torque.
- Step 4** Repeat Steps 1 through 3 to install the grounding cable to the other front door.
- Step 5** Close and lock the front ID door.

What to do next

Locate and Ground the Chassis

Locate and Ground the Chassis

Step 1 Locate the chassis grounding receptacles on your router chassis.

Figure 52: Grounding Lug— Cisco NCS 5508 or Cisco NCS 5516

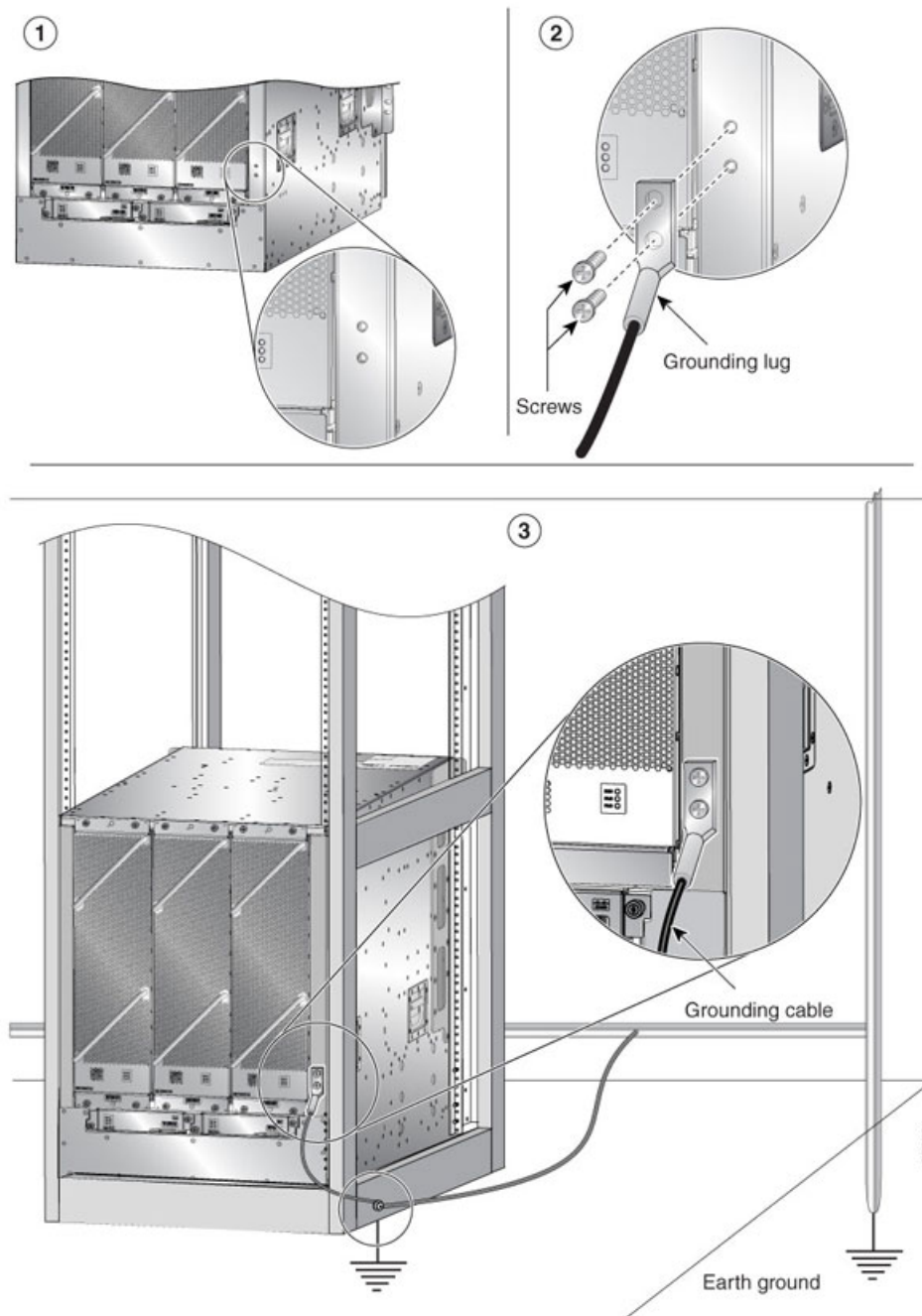

- Step 2** (Only NCS 5508 and NCS 5516) Insert the two screws through the holes in the grounding lug. Ensure that the grounding lug does not interfere with other router hardware, such as power supplies or the network processing engine.
- (Only NCS 5504) Insert one screw through the hole in the grounding lug. Ensure that the grounding lug does not interfere with other router hardware, such as power supplies or the network processing engine.

Figure 53: Grounding Lug— Cisco NCS 5504

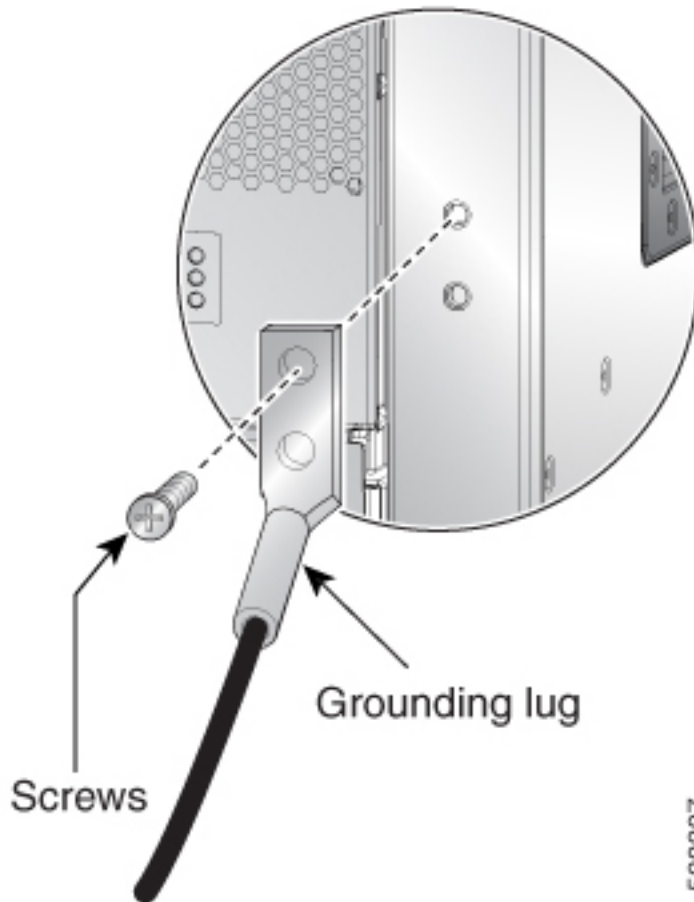

- Step 3** Use the Phillips screwdriver to carefully tighten the screws until the grounding lug is held firmly to the chassis. Do not overtighten the screws.
- Step 4** Use the wire stripper to strip one end of the 6-AWG wire approximately 0.75 inches (19.05 mm).
- Step 5** Insert the 6-AWG wire into the wire receptacle on the grounding lug.
- Step 6** Use the crimping tool to carefully crimp the wire receptacle around the wire; this step is required to ensure a proper mechanical connection.
- Step 7** Connect the opposite end of the grounding wire to the appropriate grounding point at your site to ensure an adequate chassis ground.

What to do next

Continue to start up the router.

Connect AC Power Supply to AC Power Source

Before you begin

See [Weight, Quantity and Power Consumption, on page 29](#) to ascertain the power needs for the router.



Note Take care when connecting units to the supply circuit so that wiring is not overloaded.

Step 1 For each 3-kW Standard AC power supply, connect an AC power cable to the AC power source and to the power receptacle on the power supply.

Figure 54: Connect AC Power Supply to AC Source

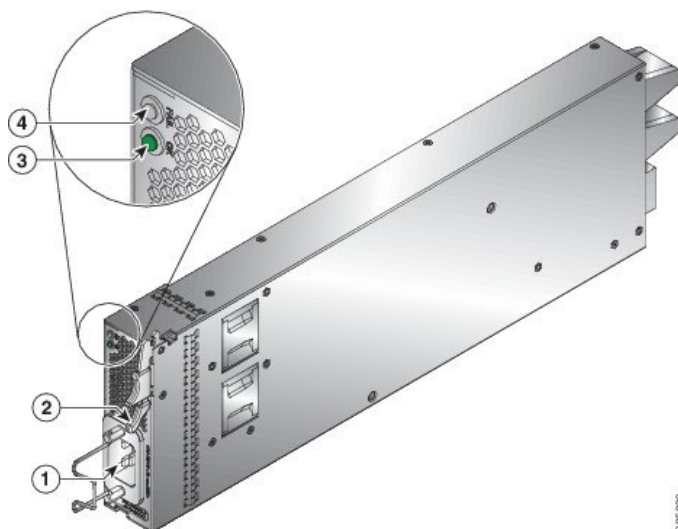

Step 2 Verify that the Output Power OK LED turns on and becomes green.

What to do next

Connect the router to the network.

Connect 3kW DC Power Supply to DC Power Source

For $n+1$ power redundancy or no power redundancy, connect all of the power supplies in the switch to the same power grid. For $n+n$ power redundancy, connect n power supplies to separate power grids (example: grid A power supplies on the left side of the switch, grid B power supplies on the right side of the switch).

Before you begin

- Install the power supplies in the chassis.
- Ensure that power is removed from the DC circuit.
- The power supplies must be close enough to be connected to the DC power source using the customer-provided power cables.
- Four 6-AWG lugs provided with the power supply.
- Customer-provided equipment and tools must include all of the following:
 - Four power cables (6 AWG cables recommended)



Note If you use colors to designate positive and negative cables, you need two cables colored for positive polarity and two cables colored for negative polarity.

- Wire stripping tool
- Crimping tool
- Torque screwdriver and wrench

-
- Step 1** Turn off the switch and circuit breaker as follows:
- a) Turn the power switch on the power supply to standby (labeled 0 on the power supply).
 - b) Turn off the circuit breaker for each of the two power inputs coming from the DC power source.
- Step 2** Connect the four customer-provided power cables to the power supply and power source as follows:
- a) Use a wire stripper to remove 0.75 inches (19 cm) of insulation from the end of each of four power cables.
 - b) Use a crimping tool to attach each of four lugs (provided with the chassis for each power supply) to the stripped end of each cable. Test each crimped lug by trying to pull it off its cable.
 - c) Use a torque screwdriver to unscrew three screws on the cover for the terminal box that is located on the front of the power supply and lift off the cover as shown in the following figure.

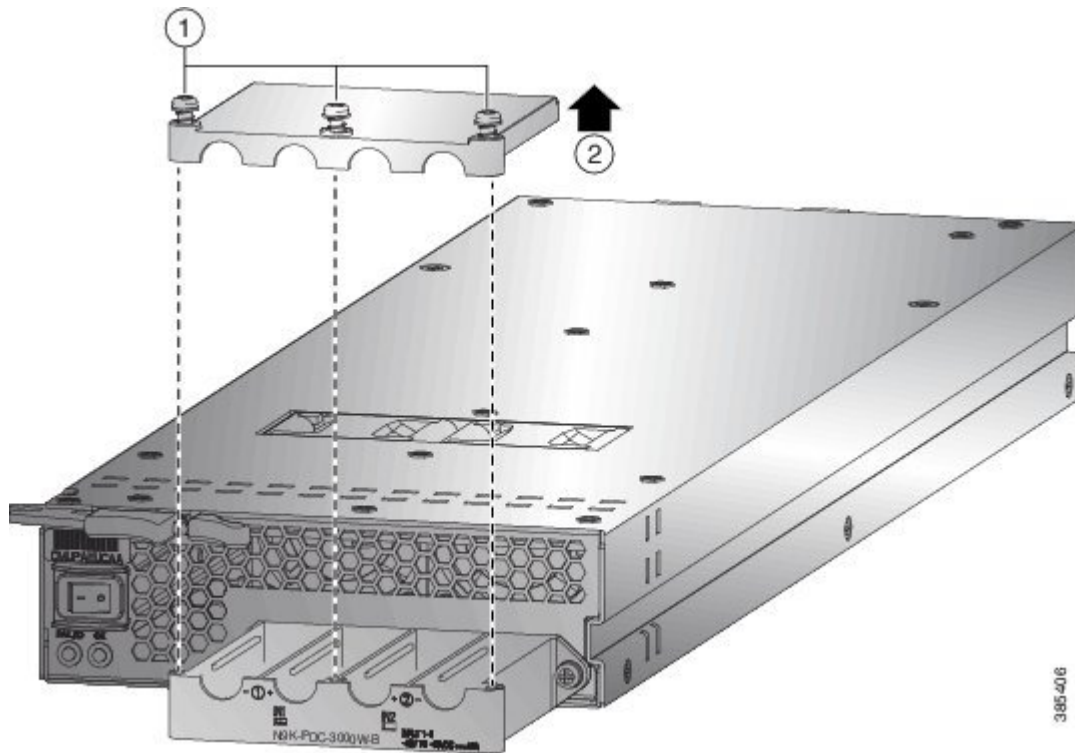

Note The terminal box has four slots for four power terminals (ordered as negative [-], positive [+], positive [+], and negative [-]). Each terminal has two nuts that you use to fasten a power cable to the terminal.

- d) Remove the two nuts from each terminal post in each slot of the terminal box.
- e) Place each of the lugs for the two positive cables on the terminal posts for the positive slots (two middle slots) of the terminal box and fasten each lug using two nuts tightened to 40 in-lb (4.5 N·m) of torque.
- f) Place each of the lugs for the two negative cables on the terminal posts for the negative slots (two outside slots) of the terminal box and fasten each lug using two nuts tightened to 40 in-lb (4.5 N·m) of torque.
- g) Replace the safety cover on the terminal box and fasten it in place using its three screws.
- h) Connect the other ends of the power cables to the two DC power circuits. Be sure that the positive and negative cables attached to one side of the power supply are attached to the same DC power source circuit (with the negative cable attached to a negative terminal and with the positive cable attached to a positive terminal).

Step 3 Power up the power supply as follows:

- a) Turn on the power source circuit breaker for both input lines. Verify that the Input 1 (IN1) and Input 2 (IN2) LEDs light up on the power supply.
- b) Turn the power switch on the power supply to ON (labeled 1 on the power supply). The LEDs should flash and then the OK LED should turn on (green) in addition to the Input LEDs.

Connect 4.4kW DC Power Supply to DC Power Source

For $n+1$ power redundancy or no power redundancy, connect all of the power supplies in the switch to the same power grid. For $n+n$ power redundancy, connect n power supplies to separate power grids (example: grid A power supplies to IN1, grid B power supplies to IN2, and so on).

Before you begin

- Ensure that power is removed from the DC circuit.
- The power supplies must be close enough to be connected to the DC power source using the customer-provided power cables.
- Six lugs of 6-AWG provided with the power supply.
- Customer-provided equipment and tools must include all the following:
 - Six power cables (6 AWG cables recommended)



Note If you use colors to designate positive and negative cables, you need three colored cables for positive polarity and three colored cables for negative polarity.

- Wire stripping tool
- Crimping tool
- Torque screwdriver and wrench

Step 1 Turn off the switch and circuit breaker as follows:

- a) Turn the power switch on the power supply to standby (labeled 0 on the power supply).
- b) Turn off the circuit breaker for each of the three power inputs coming from the DC power source.

Step 2 Connect the six customer-provided power cables to the power supply and power source as follows:

- a) Use a wire stripper to remove 0.75 inches (19 cm) of insulation from the end of each of six power cables. If you are using different colored cables for positive and negative polarity, be sure that you have three of each color (three positive cables and three negative cables).
- b) Use a crimping tool to attach each of six lugs (provided with the chassis for each power supply) to the stripped end of each cable. Test each crimped lug by trying to pull it off its cable. This ensures that the cable is crimped properly to the lug.
- c) Use a torque screwdriver to unscrew three screws, marked as 1, on the cover of the terminal box that is located on the front of the power supply. Then, lift off the safety cover in upward direction, marked as 2, as shown in the following figure.

Figure 55: NC55-PWR-4.4KW-DC Power Supply Unit

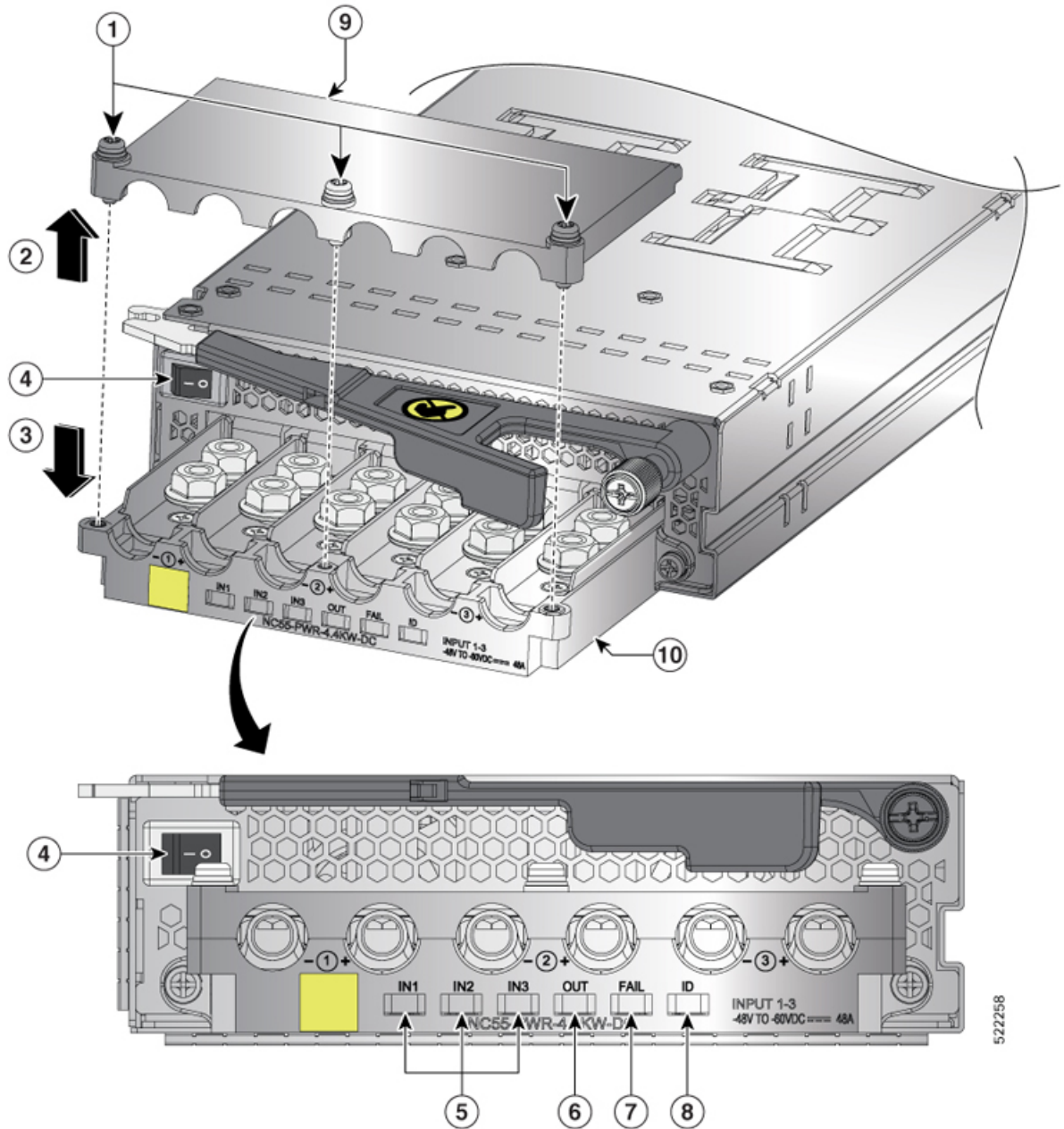

1	Screws	7	<p>FAIL LED. Glows solid amber to indicate Power Supply failure. Power supply failure reason can be one of the following:</p> <ul style="list-style-type: none"> • over voltage • over current • over temperature
---	--------	---	--

			• fan failure
4	Power Switch. 1 is ON and 0 is OFF.	8	ID LED. Blinks with blue color at 1Hz when PMBus Command (E0) is executed.
5	Input 1,2,3 (IN1, IN2, IN3) LEDs. Glows solid green when the corresponding feed in ON.	9	Safety cover
6	OUT LED. Glows solid green to indicate that the Power Supply is ON and OK.	10	Terminal box

Note The terminal box has six slots for six power terminals (ordered as negative [-], positive [+], negative [-], positive [+], negative [-], and positive [+]). Each terminal has two nuts that you use to fasten the lug that is attached to a power cable to the terminal.

- d) Remove the two nuts from each terminal post in each slot of the terminal box.
- e) Place each of the lugs for the three positive cables on the terminal posts for the positive slots of the terminal box and fasten each lug by using two nuts tightened to 40 in-lb (4.5 N·m) of torque.
- f) Place each of the lugs for the three negative cables on the terminal posts for the negative slots of the terminal box and fasten each lug using two nuts tightened to 40 in-lb (4.5 N·m) of torque.
- g) Replace the safety cover on the terminal box in the downward direction, marked as 3 in the figure, and fasten it in place using its three screws.
- h) Install the power supplies in the chassis.
- i) Connect the other ends of the power cables to the three DC power circuits. Ensure that the positive and negative cables that are attached to one side of the power supply are attached to the same DC power source circuit. With the negative cable attached to a negative terminal and the positive cable attached to a positive terminal.

Step 3 Power up the power supply as follows:

- a) Turn on the power source circuit breaker for all the three input lines. Verify that Input 1 (IN1), Input 2 (IN2), and Input 3 (IN3) LEDs light up on the power supply.
- b) Turn the power switch on the power supply to ON (labeled 1 on the power supply). The LEDs must flash and then the OK LED must turn on (green) in addition to the Input LEDs.

Connect HVAC/HVDC Power Supply to Power Source

The HVAC/HVDC power supply (NC55-PWR-3KW-2HV) has 2 redundant input power lines. It can provide power output at 3.15KW with either 1 or 2 input power lines operating. The HVAC/HVDC power supply provides $n+n$ or $n+x$ line redundancy mode in a single power supply for the NCS 5500 series modular routers.

The HVAC/HVDC power supply accepts 200–240VAC or 240/380VDC input power.

If you are not using power redundancy or are using $n+1$ power redundancy, you can connect all of the power supplies in the chassis to the same power grid. If you are using $n+n$ power redundancy, connect one set of the power supply inputs to one power grid and the other set of the power supply inputs to another power grid (for example, connect grid A to the receptacles closest to the power switch on the power supplies, and connect grid B to the receptacles furthest from the power switch on the power supplies).



Note You can have a mix of AC power supplies and HVAC/HVDC power supplies in a chassis.

Before you begin

- The AC or DC power source must be turned off at its circuit breaker.
- The power switch on the power supply must be turned off (power switch set to 0).
- The AC power sources are rated as follows:
 - For North American installations—20A with 200-240V circuits.
 - For international installations—size the circuits by local and national standards.

Step 1 For AC input, connect an AC power cable to the AC power source.

Step 2 For DC input, connect a Saf-D-Grid/Saf-D-Grid DC cable to a Saf-D-Grid receptacle, otherwise:

- a) Connect the ground terminal ring on the power cable to the ground terminal on the DC power source and secure it in place with a nut tightened to the appropriate torque setting for the terminal post.
- b) Connect the negative terminal ring on the power cable to the negative (-) terminal on the DC power source and secure it in place with a nut tightened to the appropriate torque setting for the terminal post.
- c) Connect the positive terminal ring on the power cable to the positive (+) terminal on the DC power source and secure it in place with a nut tightened to the appropriate torque setting for the terminal post.

Step 3 Connect the Saf-D-Grid connector on the other end of the power cable to the Saf-D-Grid receptacle on the power supply.

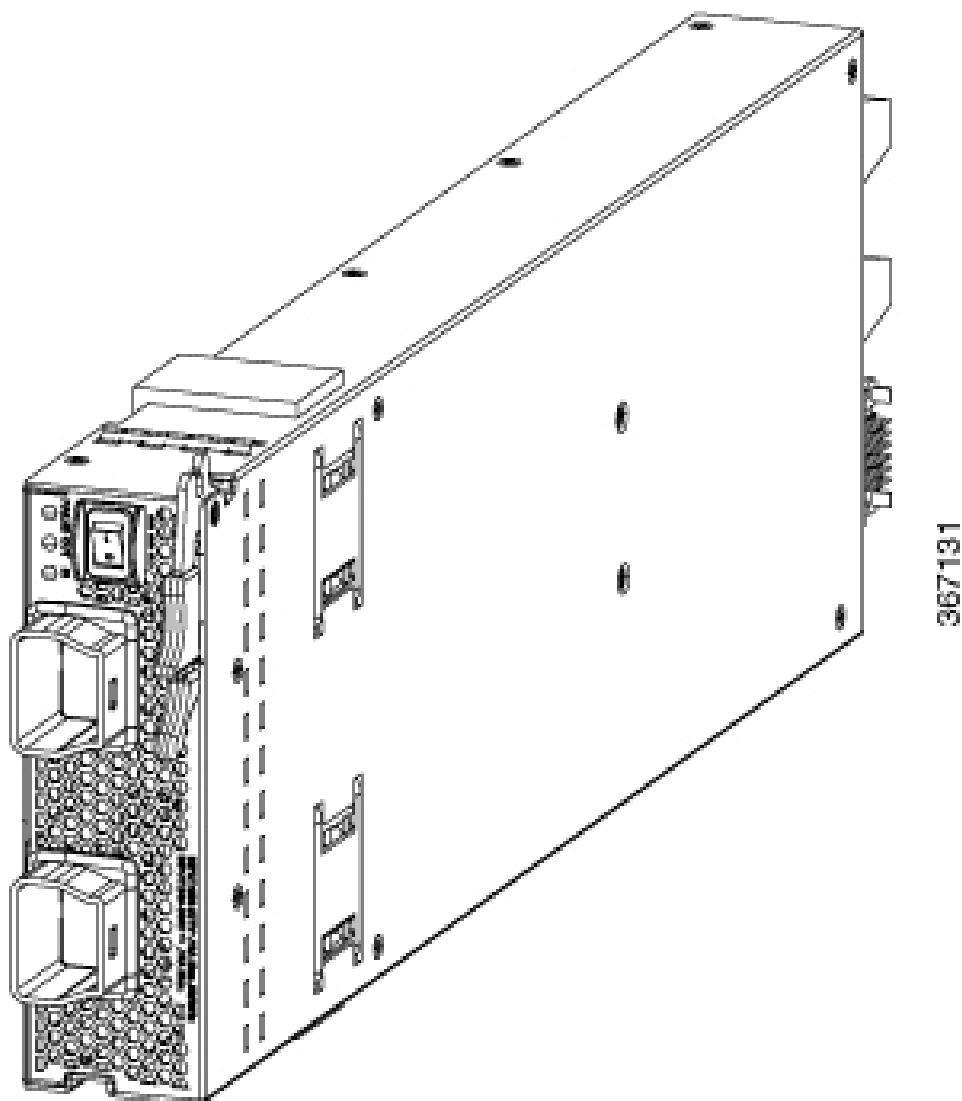

- Step 4** Turn on the circuit breaker for the DC power source circuit.
- Step 5** Turn on the power supply by pressing its power switch to on (I).
- Step 6** Verify that the OUT LED turns on and becomes green.

Note If you use both inputs, the IN LED is green. If you use only one input, the IN LED is blinking green.

What to do next

Use the **power-mgmt redundancy-num-pms** *number* command in System Admin Config mode to convert the power module redundancy from $n+1$ to $n+x$, specifying the number of redundant power modules that you want to configure. The total number of functioning power modules in the system is at least x number more than the number of power modules needed to support the power required for all the cards in the system. The range is from 0 to 5; 0 means no power redundancy is required.

```

sysadmin-vm:0_RP0# config
sysadmin-vm:0_RP0(config)# power-mgmt redundancy-num-pms 2
sysadmin-vm:0_RP0(config)# commit
Tue Sep  3 12:17:53.891 UTC
Commit complete.

```

Use the **[no] hw-module attention-led location 0/PMnumber** command in System Admin Config mode to enable or disable the ID LED on the specified power supply.

```

sysadmin-vm:0_RP0# config
sysadmin-vm:0_RP0(config)# hw-module attention-led location 0/PM2
sysadmin-vm:0_RP0(config-location-0/PM2)# commit
Tue Aug 27 18:59:28.740 UTC
Commit complete.
sysadmin-vm:0_RP0(config-location-0/PM2)# end

sysadmin-vm:0_RP0# show led location 0/PM2
Tue Aug 27 18:59:59.723 UTC
=====
Location  LED Name                               Mode      Color
=====
0/PM2
    0/PM2-FAIL                                   WORKING   OFF
    0/PM2-IN                                    WORKING   GREEN
    0/PM2-OUT                                    WORKING   GREEN
    0/PM2-ATTENTION (ID)                       WORKING   BLINKING BLUE

```



CHAPTER 4

Connect Router to the Network

- [Port Connection Guidelines](#) , on page 109
- [Connecting a Console to the Router](#), on page 110
- [Connect the Management Interface](#), on page 111
- [Installing and Removing Modular Port Adapters](#), on page 112
- [Install and Remove Transceiver Modules](#), on page 115
- [Connect Interface Ports](#), on page 124
- [Maintain Transceivers and Optical Cables](#), on page 125
- [Set Fabric Bandwidth Threshold](#), on page 125

Port Connection Guidelines

Depending on the chassis and installed line cards, you can use Quad Small Form-Factor Pluggable Plus (QSFP+), QSFP28, QSFP-DD, SFP, SFP+, CFP2, CFP-DCO, and RJ-45 connectors to connect the ports on the line cards to other network devices.

To prevent damage to the fiber-optic cables when installing a transceiver in the line card, we recommend that you disconnect the transceiver from its fiber-optic cables. Before removing the transceiver from the router, remove the cable from the transceiver. You can change or remove the cable without removing the transceiver.

To maximize the effectiveness and life of your transceivers and optical cables, do the following:

- Wear an ESD-preventative wrist strap that is connected to an earth ground whenever handling transceivers. The router is typically grounded during installation and provides an ESD port to which you can connect your wrist strap.
- Do not remove and insert a transceiver more often than is necessary. Repeated removals and insertions can shorten its useful life.
- Keep the transceivers and fiber-optic cables clean and dust free to maintain high signal accuracy and to prevent damage to the connectors. Attenuation (loss of light) is increased by contamination and should be kept below 0.35 dB.
 - Clean these parts before installation to prevent dust from scratching the fiber-optic cable ends.
 - Clean the connectors regularly; the required frequency of cleaning depends upon the environment. In addition, clean connectors when they are exposed to dust or accidentally touched. Both wet and dry cleaning techniques can be effective; refer to your site's fiber-optic connection cleaning procedures.

- Do not touch the ends of connectors. Touching the ends can leave fingerprints and cause other contamination.
- Inspect routinely for dust and damage. If you suspect damage, clean and then inspect fiber ends under a microscope to determine if damage has occurred.



Warning **Statement 1051**—Laser Radiation

Invisible laser radiation may be emitted from disconnected fibers or connectors. Do not stare into beams or view directly with optical instruments.

Connecting a Console to the Router

Before you create a network management connection for the router or connect the router to the network, you must create a local management connection through a console terminal and configure an IP address for the router. You also can use the console to perform the following functions, each of which can be performed through the management interface after you make that connection:

- Configure the router using the command-line interface (CLI).
- Monitor network statistics and errors.
- Configure Simple Network Management Protocol (SNMP) agent parameters.
- Download software updates.

You make this local management connection between the asynchronous serial port on a route processor card and a console device capable of asynchronous transmission. Typically, you can use a computer terminal as the console device. On the route processor cards, you use the console serial port.



Note Before you can connect the console port to a computer terminal, make sure that the computer terminal supports VT100 terminal emulation. The terminal emulation software makes communication between the router and computer possible during setup and configuration.

Before you begin

- The router must be fully installed in its rack, connected to a power source, and grounded.
- The necessary cabling for the console, management, and network connections must be available.
 - An RJ-45 rollover cable and DB9F/RJ-45 adapter are provided in the router accessory kit.
 - Network cabling should already be routed to the location of the installed router.

Step 1 Configure the console device to match the following default port characteristics:

- 9600 baud

- 8 data bits
- 1 stop bit
- No parity

Step 2 Connect an RJ-45 rollover cable to the CONSOLE SERIAL PORT.

You can find this cable in the accessory kit.

Step 3 Route the RJ-45 rollover cable through the center slot in the cable management system and then to the console or modem.

Step 4 Connect the other end of the RJ-45 rollover cable to the console or to a modem.

If the console or modem cannot use an RJ-45 connection, use the DB-9F/RJ-45F PC terminal adapter found in the accessory kit for the router. Alternatively, you can use an RJ-45/DSUB F/F or RJ-45/DSUB R/P adapter, but you must provide those adapters.

What to do next

You are ready to create the initial router configuration (see [Create the Initial Router Configuration, on page 127](#)).

Connect the Management Interface

The Route Processor management port (MGMT ETH) provides out-of-band management, which enables you to use the command-line interface (CLI) to manage the router by its IP address. This port uses a 10/100/1000 Ethernet connection with an RJ-45 interface.



Note In a dual Route Processor router, you can ensure that the active Route Processor card is always connected to the network by connecting the management interface on both Route Processor cards to the network. That is, you can perform this task for each Route Processor card. When the Route Processor card is active, the router automatically has a management interface that is running and accessible from the network.



Caution To prevent an IP address conflict, do not connect the MGMT 10/100/1000 Ethernet port until the initial configuration is complete. For more information, see [Create the Initial Router Configuration, on page 127](#).

Before you begin

You must have completed the initial router configuration (see [Create the Initial Router Configuration, on page 127](#)).

Step 1 Connect a modular, RJ-45, UTP cable to the MGMT ETH port on the Route Processor card.

Step 2 Route the cable through the central slot in the cable management system.

Step 3 Connect the other end of the cable to a 10/100/1000 Ethernet port on a network device.

What to do next

You are ready to connect the interface ports on each of the line cards to the network.

Installing and Removing Modular Port Adapters

The following sections describe how to install or remove MPA:

Handling Modular Port Adapters

Each modular port adapter (MPA) circuit board is mounted to a metal carrier and is sensitive to electrostatic discharge (ESD) damage.



Caution Always handle the MPA by the carrier edges and handle; never touch the MPA components or connector pins (See the figure below).

When a bay is not in use, a blank MPA Slot Filler must fill the empty bay to allow the router or switch to conform to electromagnetic interference (EMI) emissions requirements and to allow proper airflow across the installed modules. If you plan to install a MPA in a bay that is not in use, you must first remove the blank.

Figure 56: Handling a Modular Port Adapter

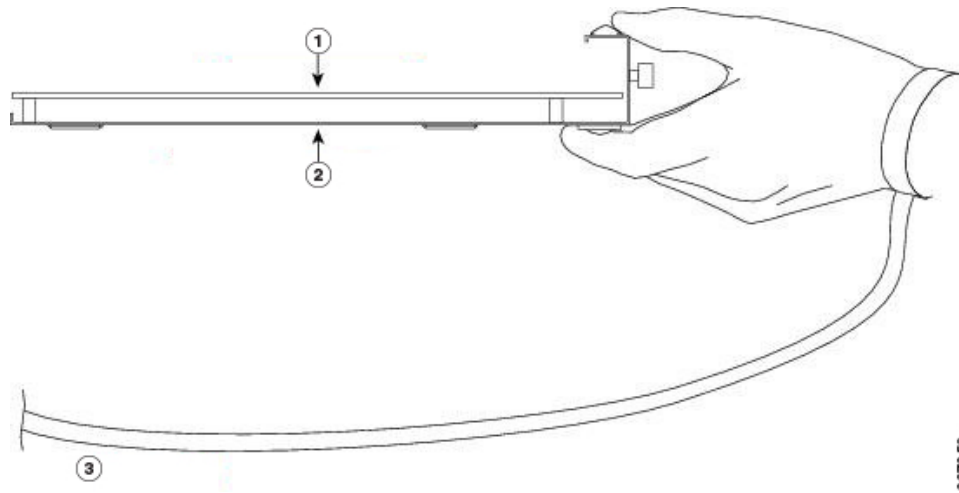

1	Printed Circuit Board	2	Metal Carrier
3	Grounding Strap		

Online Insertion and Removal



Caution Cisco IOS XR Software 6.6.1 and later releases support online insertion and removal (OIR) of Cisco NCS 5500 series modular port adapters (MPAs).

Cisco NCS 5500 series modular port adapters (MPAs) support online insertion and removal (OIR). Modular port adapters (MPAs) can be inserted or removed independently from the modular line card (MLC). OIR of a MLC with installed modular port adapters (MPAs) is also supported.

Limitation:

- During online insertion and removal of MPA on the Cisco ASR 9000 Series router, the field-programmable gate array (FPGA) turns off and the physical interface (PHY) is unavailable to inhibit the clock. As a result, you will observe a SyncE jump of 80 - 120 ns on downstream nodes.

Modular port adapters (MPAs) support the following types of OIR:

- Soft OIR

Soft OIR uses the IOS XR **hw-module subslot** *rack/slot/subslot* **reload**, **hw-module subslot** *rack/slot/subslot* **shutdown**, and **no hw-module subslot** *rack/slot/subslot* **shutdown** commands to complete online insertion and removal.

- Managed OIR

A managed online insertion and removal of Modular port adapters (MPAs) is comprised of the following steps:

- Shut down the MPA with the **hw-module subslot** *rack/slot/subslot* **shutdown** command.
- Confirm that the LEDs have gone from green to off.
- Execute the **do show platform** command to verify that the MPA to be removed is in the disabled state.
- Physically remove the MPA to be replaced.
- Physically insert the replacement MPA. After inserting the MPA in the slot, tighten the MPA screw located on the right side within 10 seconds. Ensure that you first tighten the right screw and then the left.



Note Tighten the captive screws on the MPA within 10 seconds. Otherwise, the MPA shuts down and moves to **Disabled** state. To recover the MPA, tighten both the captive screws and then execute the **hw-module subslot** *rack/slot/subslot* **reload** command.

- Return the MPA to the up state with the **no hw-module subslot** *rack/slot/subslot* **shutdown** command.

- Hard OIR

You can perform the OIR in a running system, by performing the following steps, without executing any commands:

- Loosen the right ejector screw.
- Loosen the left ejector screw.
- Remove and replace the MPA.

Modular Port Adapter Installation and Removal

This section provides step-by-step instructions for removing and installing a modular port adapter (MPA) in a NC55-MOD-A-S and NC55-MOD-A-SE-S modular line card (MLC).



Note After you remove the MPA from the slot, wait for 60 seconds before you reinsert the MPA.



Note After you unscrew both ejector screws, wait for 15 seconds before removing MPA from the slot.



Warning During this procedure, wear grounding wrist straps to avoid ESD damage to the card. Do not directly touch the backplane with your hand or any metal tool, or you could shock yourself. Statement 94

To remove and install a MPA, do the following:

1. To insert the MPA, locate the guide rails inside the MLC that hold the MPA in place. They are at the bottom left and bottom right of the MPA slot and are recessed about an inch.
2. Carefully slide the MPA all the way in the MLC until the MPA is firmly seated in the MPA interface connector. When fully seated, the MPA might be slightly behind the faceplate.



Note The MPA will slide easily into the slot if it is properly aligned on the tracks. If the MPA does not slide easily, do NOT force it. Remove the MPA and reposition it, paying close attention to engaging it on the tracks. Push the MPA inside the slot until you hear a click. Continue to push the MPA further until you hear a second click. The MPA is fully seated only after the second click is heard.

3. After the MPA is properly seated, use a number 2 Phillips screwdriver to tighten the captive screws on the MPA. Ensure that you first tighten the right screw and then the left.



Note Tighten the captive screws on the MPA within 10 seconds. Otherwise, the MPA shuts down and moves to **Disabled** state. To recover the MPA, tighten both the captive screws and then execute the **hw-module subslot rack/slot/subslot reload** command.



Note Avoid over torquing the MPA captive screws when installing the MPA. Tighten the captive screws on the MPA to a torque of 6 +/-0.5 inch-pound.

4. To remove the MPA from the MLC, use a number 2 Phillips screwdriver to loosen the captive screws on the MPA. Ensure that you first loosen the right screw and then the left.
5. Grasp the MPA and pull the MPA from the MLC. (You have already disconnected the cables from the MPA.)

Install and Remove Transceiver Modules

Install and Remove SFP Modules

Before you remove or install an SFP or SFP+ module, read the installation information in this section.



Warning Invisible laser radiation may be emitted from disconnected fibers or connectors. Do not stare into beams or view directly with optical instruments. Statement 1051



Caution Protect the line card by inserting a clean SFP/SFP+ module cage cover, shown in the figure below, into the optical module cage when there is no SFP or SFP+ module installed.

Figure 57: SFP/SFP+ Module Cage Cover

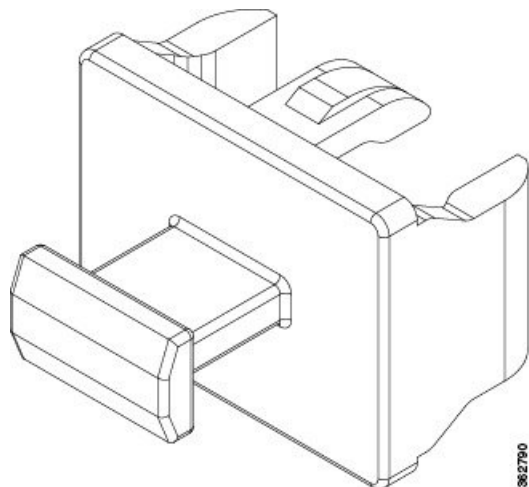



Caution Protect the SFP or SFP+ modules by inserting clean dust covers into them after the cables are removed. Be sure to clean the optic surfaces of the fiber cables before you plug them back into the optical ports of another module. Avoid getting dust and other contaminants into the optical ports of your SFP or SFP+ modules, because the optics do not work correctly when obstructed by dust.



Caution We strongly recommended that you do not install or remove the SFP or SFP+ module with fiber-optic cables attached to it because of the potential of damaging the cable, the cable connector, or the optical interfaces in the module. Disconnect all cables before removing or installing an SFP or SFP+ module. Removing and inserting a module can shorten its useful life, so you should not remove and insert modules any more than is absolutely necessary.



Note When installing an SFP or SFP+ module, you should hear a click as the triangular pin on the bottom of the module snaps into the hole in the receptacle. The click indicates that the module is correctly seated and secured in the receptacle. Verify that the modules are completely seated and secured in their assigned receptacles on the line card by firmly pushing on each SFP or SFP+ module.

Bale Clasp SFP or SFP+ Module

The bale clasp SFP or SFP+ module has a clasp that you use to remove or install the module (see the figure below).

Figure 58: Bale Clasp SFP or SFP+ Module

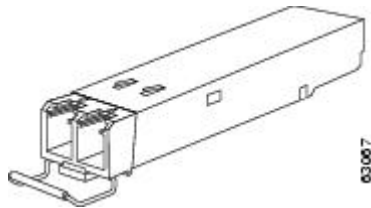

Install a Bale Clasp SFP or SFP+ Module

To install this type of SFP or SFP+ module, follow these steps:

- Step 1** Attach an ESD-preventive wrist or ankle strap and follow its instructions for use.
- Step 2** Close the bale clasp before inserting the SFP module.
- Step 3** Line up the SFP module with the port and slide it into the port (see the figure below).

Figure 59: Installing a Bale Clasp SFP Module into a Port

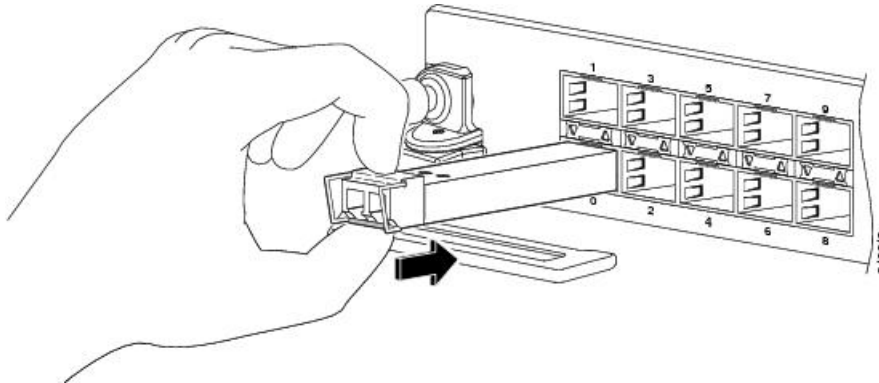

Note When installing an SFP or SFP+ module, you should hear a click as the triangular pin on the bottom of the SFP module snaps into the hole in the receptacle. This click indicates that the module is correctly seated and secured in the receptacle. Verify that the SFP modules are completely seated and secured in their assigned receptacles on the line card by firmly pushing on each SFP module.

Remove a Bale Clasp SFP or SFP+ Module

To remove this type of SFP or SFP+ module, follow these steps:

- Step 1** Attach an ESD-preventive wrist or ankle strap and follow its instructions for use.
- Step 2** Disconnect and remove all interface cables from the ports; note the current connections of the cables to the ports on the line card.
- Step 3** Open the bale clasp on the SFP module with your index finger, as shown in the figure below. If the bale clasp is obstructed and you cannot use your index finger to open it, use a small flat-blade screwdriver or other long, narrow instrument to open the bale clasp.
- Step 4** Grasp the SFP module between your thumb and index finger and carefully remove it from the port, as shown in the figure below.

Note This action must be performed during your first instance. After all the ports are populated, this may not be possible.

Figure 60: Removing a Bale Clasp SFP or SFP+ Module

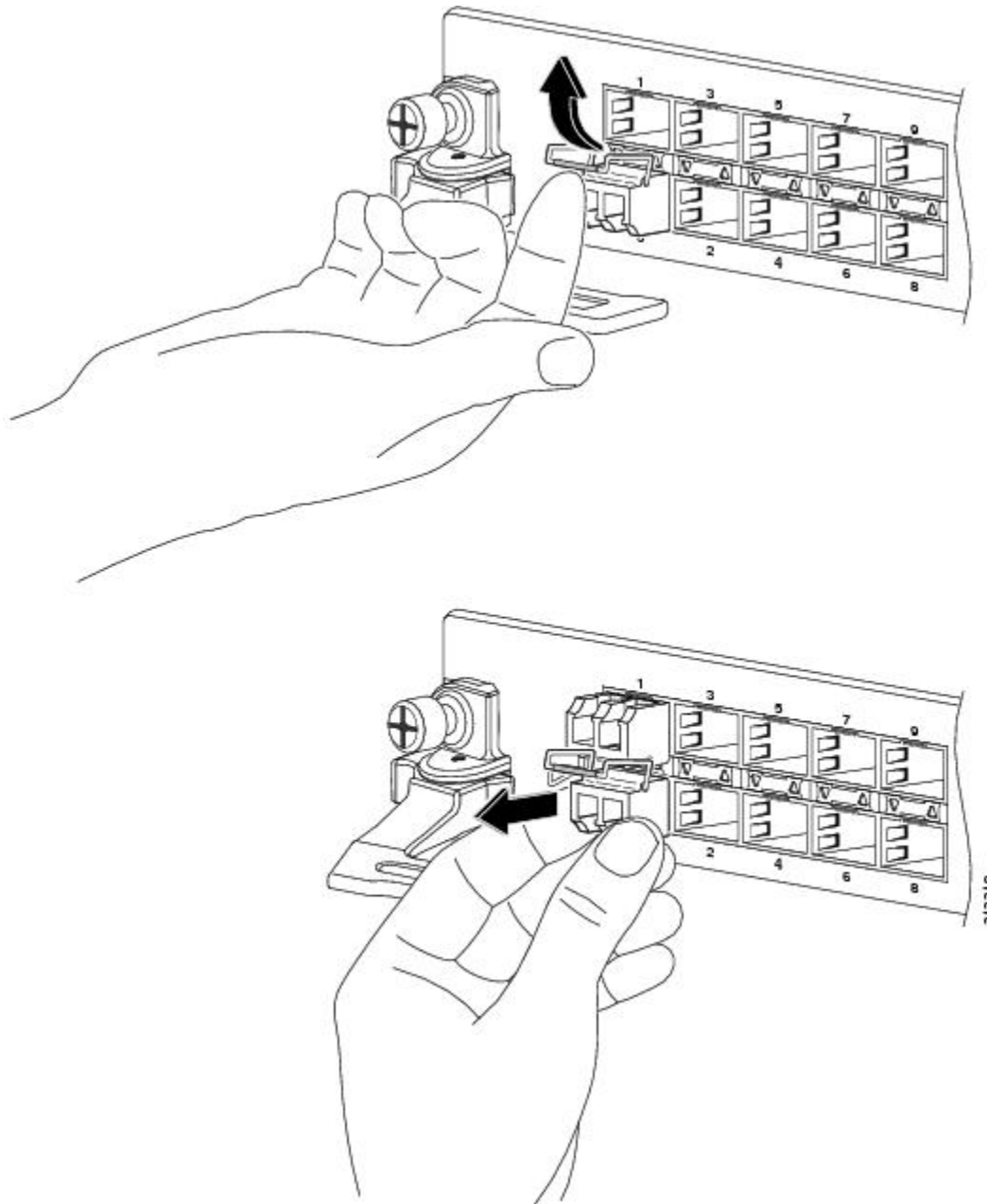

- Step 5** Place the removed SFP module on an antistatic mat, or immediately place it in a static shielding bag if you plan to return it to the factory.
- Step 6** Protect your line card by inserting a clean SFP module cage covers into the optical module cage when there is no SFP module installed.

Install and Remove QSFP Transceiver Modules



Note In this section, QSFP refers to QSFP+, QSFP28, and QSFP-DD. Refer to the [Cisco Optical Transceiver Handling Guide](#) for additional details on optical transceivers.

This section provides the installation, cabling, and removal instructions for the Quad Small Form-Factor Pluggable (QSFP) transceiver modules. The modules are hot-swappable input/output (I/O) devices that connect the system’s module port electrical circuitry with either a copper or a fiber-optic network.

The following figure shows the 400-Gigabit QSFP-DD transceiver module.

Figure 61: 400-Gigabit QSFP-DD Transceiver Module

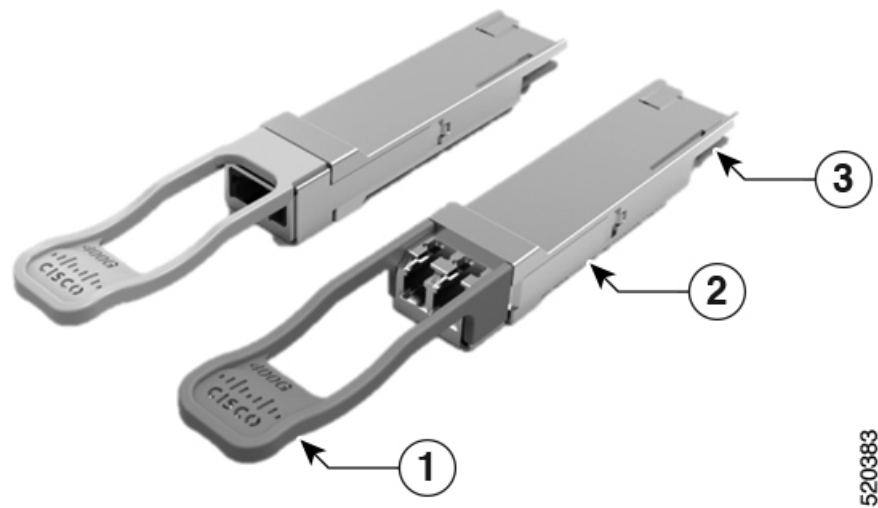

1	Pull-tab	2	QSFP-DD transceiver body
3	Electrical connection to the module circuitry		



Warning **Statement 1079**—Hot Surface

This icon is a hot surface warning. Use precaution when working near the hot surface.



Required Tools and Equipment

You need these tools to install the transceiver modules:

- Wrist strap or other personal grounding device to prevent ESD occurrences.

- Antistatic mat or antistatic foam to set the transceiver on.
- Fiber-optic end-face cleaning tools and inspection equipment.

For information on inspecting and cleaning fiber-optic connections, see [Maintain Transceivers and Optical Cables](#).

Installing the QSFP Transceiver Module



Caution The QSFP transceiver module is a static-sensitive device. Always use an ESD wrist strap or similar individual grounding device when handling QSFP transceiver modules or coming into contact with system modules.

The QSFP transceiver module has a pull-tab latch. To install a QSFP transceiver module, follow these steps:

- Step 1** Attach an ESD wrist strap to yourself and a properly grounded point on the chassis or the rack.
- Step 2** Remove the transceiver module from its protective packaging.
- Step 3** Check the label on the transceiver module body to verify that you have the correct model for your network. Do not remove the dust plug until you're ready to attach the network interface cable. Dust plug is not shown in the images.
- Step 4** Hold the transceiver by the pull-tab so that the identifier label is on the top.
- Step 5** Align the transceiver module in front of the module's transceiver socket opening and carefully slide the transceiver into the socket until the transceiver makes contact with the socket electrical connector (see the figure below).

Figure 62: Installing the QSFP Transceiver Module

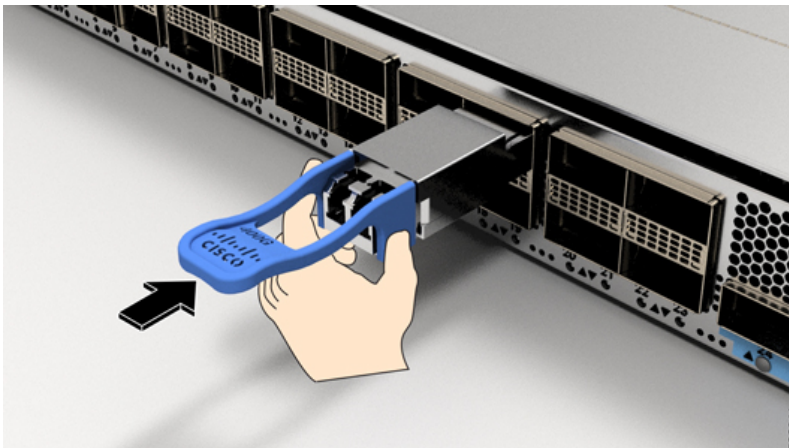

- Step 6** Press firmly on the front of the transceiver module with your thumb to fully seat the transceiver in the module's transceiver socket (see the below figure).

Caution If the latch is not fully engaged, you might accidentally disconnect the transceiver module.

Figure 63: Seating the QSFP Transceiver Module

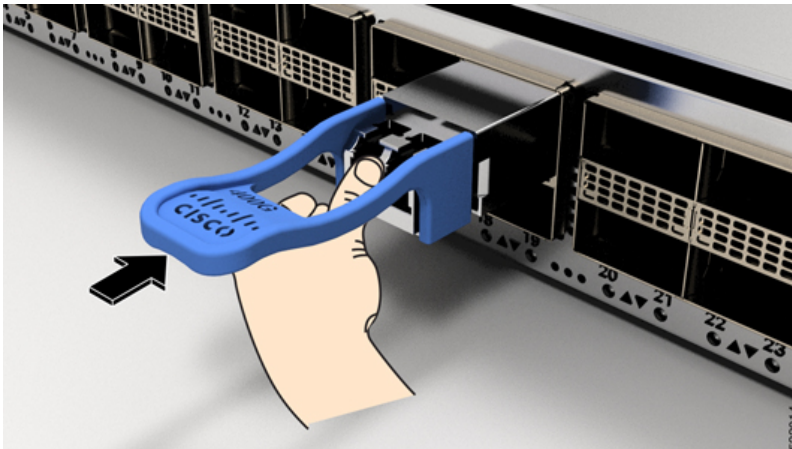

Attach the Optical Network Cable

Before you begin

Before you remove the dust plugs and make any optical connections, follow these guidelines:

- Keep the protective dust plugs installed in the unplugged fiber-optic cable connectors and in the transceiver optical bores until you are ready to make a connection.
- Inspect and clean the MPO connector end faces just before you make any connections. For complete information on inspecting and cleaning fiber-optic connections, see the [Inspection and Cleaning Procedures for Fiber-Optic Connections](#) document.
- Grasp the MPO connector only by the housing to plug or unplug a fiber-optic cable.



Note QSFP transceiver modules are keyed to prevent incorrect insertion.



Note The multiple-fiber push-on (MPO) connectors on the optical QSFP transceivers support network interface cables with either physical contact (PC) or ultra-physical contact (UPC) flat polished face types. The MPO connectors on the optical QSFP transceivers do not support network interface cables with an angle-polished contact (APC) face type.

- Step 1** Remove the dust plugs from the optical network interface cable MPO connectors. Save the dust plugs for future use.
- Step 2** Inspect and clean the MPO connector's fiber-optic end faces.
- Step 3** Remove the dust plugs from the transceiver module optical bores.
- Step 4** Immediately attach the network interface cable MPO connectors to the transceiver module (see the figure below).

Figure 64: Cabling a Transceiver Module

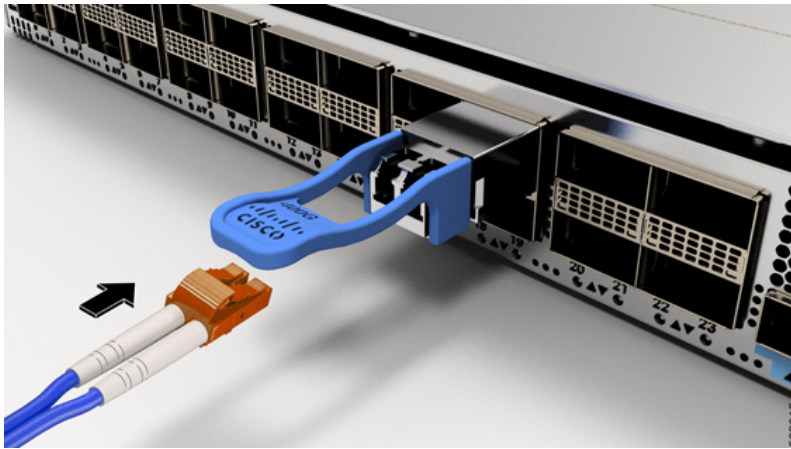

Removing the QSFP Transceiver Module



Caution The QSFP transceiver module is a static-sensitive device. Always use an ESD wrist strap or similar individual grounding device when handling transceiver modules or coming into contact with modules.

To remove a QSFP transceiver module, follow these steps:

- Step 1** Disconnect the network interface cable from the transceiver connector.
- Step 2** Install the dust plug immediately into the transceiver's optical bore
- Step 3** Grasp the pull-tab and gently pull to release the transceiver from the socket.

Figure 65: Removing the QSFP Transceiver Module

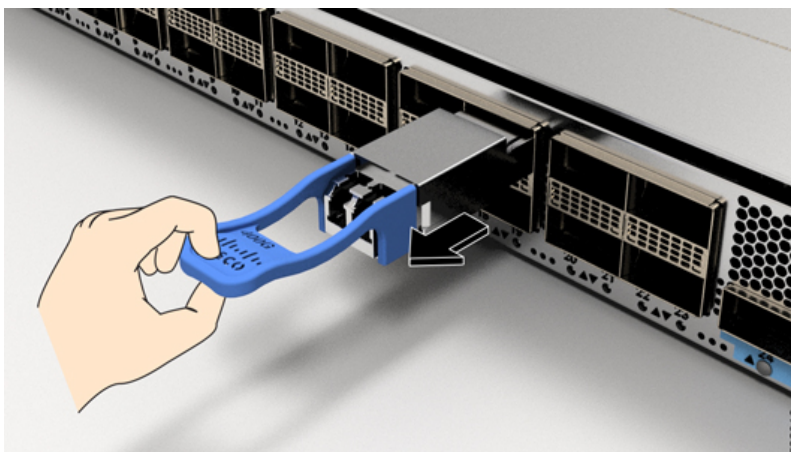

- Step 4** Slide the transceiver out of the socket.

Step 5 Place the transceiver module into an antistatic bag.

Installing and Removing CFP2 Modules

Before you remove or install a CFP2 module, read the installation information in this section.



Warning Invisible laser radiation may be emitted from disconnected fibers or connectors. Do not stare into beams or view directly with optical instruments. Statement 1051



Caution The CFP2 module is a static-sensitive device. Always use an ESD wrist strap or similar individual grounding device when handling the CFP2 modules or coming into contact with the modules.

Installing a CFP2 Module

To install a CFP2 module, follow these steps:

Step 1 Attach an ESD-preventive wrist or ankle strap and follow its instructions for use.

Step 2 Align the CFP2 module into the transceiver port socket of the line card.

Figure 66: Aligning a CFP2 Module into a Port Socket

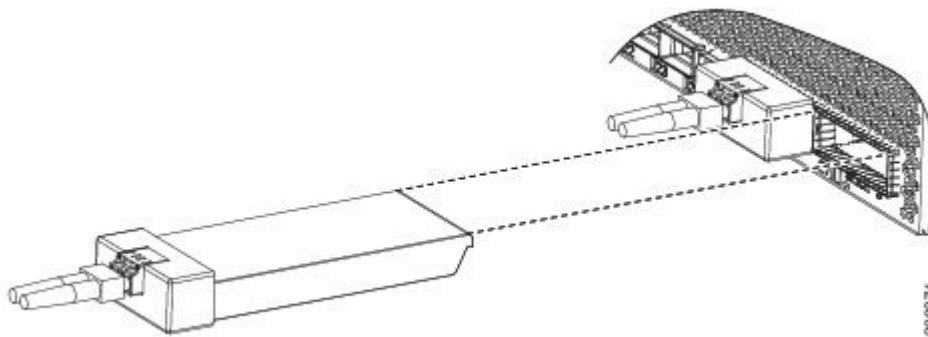

Step 3 Slide the CFP2 module in until the EMI gasket flange makes contact with the line card faceplate.

Step 4 Press firmly on the front of the CFP2 module with your thumbs to fully seat it in the transceiver socket.

The CFP2 module is properly seated in the slot by applying symmetrical force of at least 80N on its front surface, along the centerline. The latching mechanisms on both the sides of the pluggable should be fully engaged, and the electrical connectors should be completely mated.

Figure 67: Installing a CFP2 Module into a Port Socket

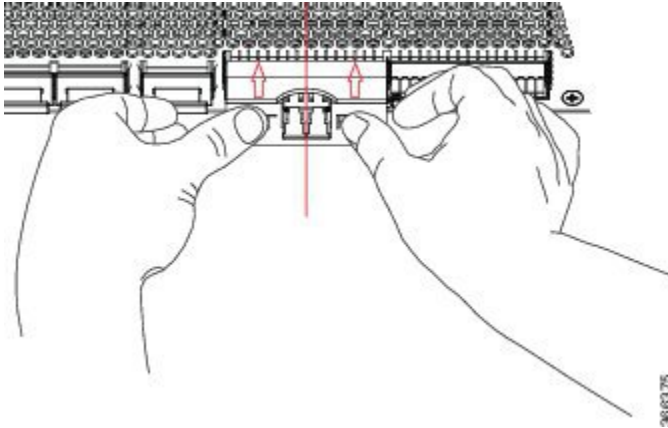

Step 5 When you are ready to attach the network cable interface, remove the dust plugs and inspect and clean fiber connector end faces, and then immediately attach the network interface cable connectors into the CFP2 module optical bores.

Note Online insertion and removal (OIR): When you insert a CFP2 module that is configured for 150Gbps (8 QAM), there will be a delay in the laser-on process for both optics controllers due to flapping. This laser-on process can take up to 120 seconds to complete.

Removing a CFP2 Module

To remove a CFP2 module, follow these steps:

-
- Step 1** Attach an ESD-preventive wrist or ankle strap and follow its instructions for use.
 - Step 2** Disconnect and remove all interface cables from the ports; note the current connections of the cables to the ports on the line card.
 - Step 3** Open the bail latch on the CFP2 module with your index finger. If the bail latch is obstructed and you cannot use your index finger to open it, use a small flat-blade screwdriver or other long, narrow instrument to open the bail latch.
 - Step 4** Grasp the CFP2 module between your thumb and index finger and carefully remove it from the port.
 - Step 5** Place the removed CFP2 module on an antistatic mat, or immediately place it in a static shielding bag if you plan to return it to the factory.
-

Connect Interface Ports

You can connect optical interface ports on line cards with other devices for network connectivity.

Connect a Fiber-Optic Port to the Network

Depending on the line card model that you are using, you can use either QSFP+ or QSFP28 transceivers. Some transceivers work with fiber-optic cables that you attach to the transceivers and other transceivers work

with pre-attached copper cables. When installing fiber-optic cables for a port, you must install SFP transceivers for 1-Gigabit optical ports or install SFP+ transceivers for 10-Gigabit optical ports or QSFP+ transceivers for 100-Gigabit ports before installing the fiber-optic cable in the transceivers.



Caution Removing and installing a transceiver can shorten its useful life. Do not remove and insert transceivers more than it is absolutely necessary. We recommend that you disconnect cables before installing or removing transceivers to prevent damage to the cable or transceiver.

Disconnect Optical Ports from the Network

When you need to remove fiber-optic transceivers, you must first remove the fiber-optic cables from the transceiver before you remove the transceiver from the port.

Maintain Transceivers and Optical Cables

To maintain high signal accuracy and to prevent damage to the connectors, transceivers and fiber-optic cables must be kept clean and free of dust. Attenuation (loss of light) is increased by contamination and should be below 0.35 dB.

Refer to [Inspection and Cleaning Procedures for Fiber-Optic Connections](#) document for inspection and cleaning processes for fiber optic connections.

Set Fabric Bandwidth Threshold

Fabric bandwidth refers to the percentage of the number of active fabric links and total available links between each NPU and all available fabric cards. Fabric bandwidth algorithm monitors the number of active links on all NPUs of each line card and turns the line card interfaces on or off. If the number of active links cross the threshold, the algorithm turns on all interfaces, and if the number of active links are less than threshold - 2, the interfaces are turned off. This value of -2 is used to avoid frequent flaps. The value indicates that the `bring down threshold` is kept 2 fabric links per ASIC below the `bring up threshold`.



Note All line card interfaces will be turned off even if one of the NPU links is down below the required threshold and will be turned on only after all NPU links of that line card are above the configured bandwidth threshold. The fabric bandwidth algorithm is not applicable to NPU-only fixed devices where the fabric links are not connected.

The Bandwidth Threshold acts a check point to ensure substantial bandwidth availability to carry traffic to the fabric cards. To configure the bandwidth threshold, use the following commands:

```
Router# configure
Router(config)# hw-module profile bw-threshold ?
WORD value in percent: 0-100, in increments of 10
Router(config)# hw-module profile bw-threshold 90
```



Note The bandwidth threshold configuration takes effect only on a fabric link related activity.

User can set the threshold value starting with 10 and in increments of 10. The default is 10%.



CHAPTER 5

Create Initial Configuration

- [Create the Initial Router Configuration, on page 127](#)
- [Verify Chassis Installation, on page 129](#)

Create the Initial Router Configuration

You must assign an IP address to the router management interface so that you can then connect the router to the network.

When you initially power up the router, it boots up and asks a series of questions to help configure the router. To enable you to connect the router to the network, you can use the default choices for each configuration except for the IP address, which you must provide.



Note These routers are designed to boot up in less than 30 minutes, provided the neighboring devices are in full operational state.



Note Be aware of the router's unique name to identify it among the other devices in the network.

Before you begin

- A console device must be connected with the router.
- The router must be connected to a power source.
- Determine the IP address and netmask needed for the Management interfaces: `MgmtEth0/RP0/CPU0/0` and `MgmtEth0/RP1/CPU0/0`.

Step 1 Power up the router.

The LEDs on each power supply light up (green) when the power supply units are sending power to the router, and the software asks you to specify a password to use with the router.

Step 2 When the system is booted up for the first time, a new username and a password is to be created. The following prompt appears:

```
!!!!!!!!!!!!!!!!!!!!!!!!!!!! NO root-system username is configured. Need to configure root-system username.
!!!!!!!!!!!!!!!!!!!!!!!!!!!!

--- Administrative User Dialog ---

Enter root-system username:
% Entry must not be null.

Enter root-system username: root
Enter secret:
Use the 'configure' command to modify this configuration.
User Access Verification

Username: root
Password:

RP/0/RP0/CPU0:ios#
```

Step 3 Enter a new password to use for this router.

The software checks the security strength of it and rejects your password if it is not considered to be a strong password. To increase the security strength of your password, make sure that it adheres to the following guidelines:

- At least eight characters
- Minimizes or avoids the use of consecutive characters (such as "abcd")
- Minimizes or avoids repeating characters (such as "aaa")
- Does not contain recognizable words from the dictionary
- Does not contain proper names
- Contains both uppercase and lowercase characters
- Contains both numbers and letters

Note Clear text passwords cannot include the dollar sign (\$) special character.

Tip If a password is trivial (such as a short, easy-to-decipher password), the software rejects the password configuration. Be sure to configure a strong password as described by the guidelines in this step. Passwords are case sensitive.

If you enter a strong password, the software asks you to confirm the password.

Step 4 Reenter the password.

When you enter the same password, the software accepts the password .

Step 5 Enter the IP address for the management interface.

Step 6 Enter a network mask for the management interface.

Step 7 The software asks whether you want to edit the configuration. Enter **no** to not edit the configuration.

Step 8 The software asks whether you want to save the configuration. Enter **yes** to save the configuration.

Verify Chassis Installation

After installing the chassis, use the following **show** commands to verify the installation and configuration. If any issue is detected, take corrective action before making further configurations.

Command	Description
show inventory	Displays information about the field replaceable units (FRUs), including product IDs, serial numbers, and version IDs.
show environment	Displays all of the environment-related router information.
show environment temperature	<p>Displays temperature readings for card temperature sensors. Each system controller, route processor, line card, and fabric card has temperature sensors with two thresholds:</p> <ul style="list-style-type: none"> • Minor temperature threshold – When a minor threshold is exceeded, a minor alarm occurs and the following actions occur for all four sensors: <ul style="list-style-type: none"> • Displays system messages • Sends SNMP notifications (if configured) • Log environmental alarm event that can be reviewed by running the show alarm command. • Major temperature threshold – When a major threshold is exceeded, a major alarm occurs and the following actions occur: <ul style="list-style-type: none"> • For sensors 1, 3, and 4 (outlet and onboard sensors), the following actions occur: <ul style="list-style-type: none"> • Displays system messages. • Sends SNMP notifications (if configured). • Logs environmental alarm event that can be reviewed by running the show alarm command. • For sensor 2 (intake sensor), the following actions occur: <ul style="list-style-type: none"> • If the threshold is exceeded in a switching card, only that card is shut down. • If the threshold is exceeded in an active route processor card with HA-standby or standby present, only that route processor card is shut down and the standby route processor card takes over. • If you do not have a standby route processor card in your router, you have up to 2 minutes to decrease the temperature. During this interval, the software monitors the temperature every 5 seconds and continuously sends system messages as configured. <p>Note Cisco recommends that you install dual route processor cards. If you are using a router without dual route processor cards, Cisco recommends that you immediately replace the fan card if just one fan is not working.</p>

Command	Description
show environment power	Displays the power usage information for the entire router.
show environment voltage	Displays the voltage for the entire router.
show environment current	Displays the current environment status.
show environment fan	Displays the status of the fan trays.



CHAPTER 6

Replace Chassis Components



Note The images in this chapter are only for representation purposes, unless specified otherwise. The chassis' actual appearance and size may vary.

- [Replace a Route Processor Card, on page 131](#)
- [Replace a System Controller Module, on page 135](#)
- [Installing and Removing a Blank Line Card , on page 137](#)
- [Replace a Line Card, on page 140](#)
- [Replace a Fan Tray, on page 145](#)
- [Replace Fabric Card, on page 149](#)
- [Replace Power Supplies, on page 157](#)

Replace a Route Processor Card

The router supports up to two redundant route processor cards. When two route processor cards are installed in the router, one acts as an active card and the other as the standby card. When the active route processor card is removed, the router automatically makes the standby route processor card active and the card that you are removing, the standby route processor. If the router has only one route processor card installed, a new route processor can be installed in the empty route processor slot during operation.



Warning **Statement 1029**—Blank Faceplates and Cover Panels

Blank faceplates and cover panels serve three important functions: they prevent exposure to hazardous voltages and currents inside the chassis; they contain electromagnetic interference (EMI) that might disrupt other equipment; and they direct the flow of cooling air through the chassis. Do not operate the system unless all cards, faceplates, front covers, and rear covers are in place.



Warning **Statement 1034**—Backplane Voltage

Hazardous voltage or energy is present on the backplane when the system is operating. Use caution when servicing



Note Before replacing the card, you must perform a graceful shutdown of the card to avoid disk corruption.

Watch [Replace a Route Processor Card \(Video\)](#)

-
- Step 1** Open the packaging for the new route processor card, inspect the card for damage, and verify that the card is the same type as the other route processor card installed in the chassis.
- If the card is damaged, alert the Technical Assistance Center (TAC).
- Step 2** If you are installing the card in an empty slot, remove the blank card that is already in that slot by unscrewing its captive screw and pulling it out of the slot. Go to Step 4.
- Step 3** If you are replacing a card that is currently in the chassis, remove the existing card from the chassis by following these steps:
- a) Disconnect the following cables from the card:
 - Console cable
 - Ethernet Management cable
 - b) If there are any external drives attached to the card through its USB ports, detach those drives.
 - c) Run the **hw-module location <loc> shutdown** command in admin EXEC mode, which gracefully shuts down route processor module to prevent any of the file systems from being corrupted.
 - d) Verify that the route processor Status (STS) LED for the slot that you specified turns off. Also, you can verify that the card is in powered off state running the **show platform** command to verify the status of the card to be **POWERED_OFF**.
 - e) Slide the middle section of the ejector handle toward the end of the handle and rotate the handle away from the front of the card (see Callouts 1 and 2 in the following figure).

The card unseats its connectors from the midplane and moves slightly out of the chassis.

Figure 68: Remove Route Processor card from Chassis

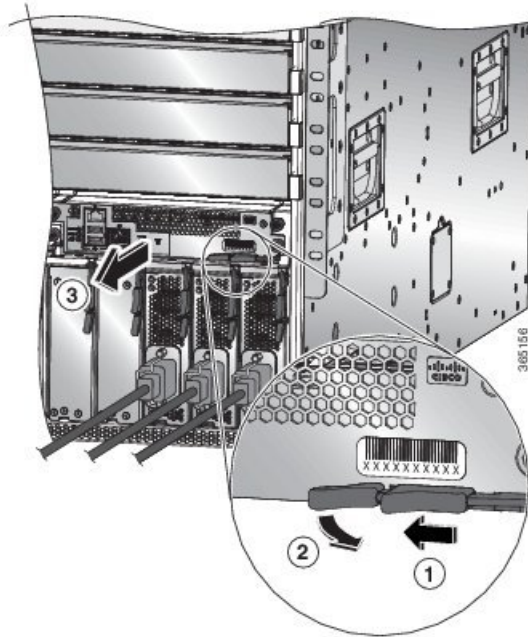

1	Slide the middle handle toward the end of the ejector lever.	2	Rotate the ejector lever away from the card.
3	Pull on the lever to slide the card part way out of the chassis. Release the lever, hold the front of the card and pull the card all the way out of the chassis.		

- f) Use one hand to hold the front of the card, place your other hand under the card to support its weight, pull the card out of the chassis, and set it on an antistatic surface or inside an antistatic bag.

Step 4

To install a new card, follow these steps:

- a) Pull the middle section of the ejector handle toward the end of the handle and rotate the handle away from the front of the card.

This action opens the lever so that the card can be fully inserted into the slot.

- b) Hold the front of the card with one hand and place your other hand under the card to support its weight.
- c) Align the back of the card to the guides in the open route processor slot and slide the card all the way into the slot (see the following figure).

The card stops when its front is about 0.25 inches (0.6 cm) outside the front of the chassis.

Figure 69: Install route processor card into Chassis

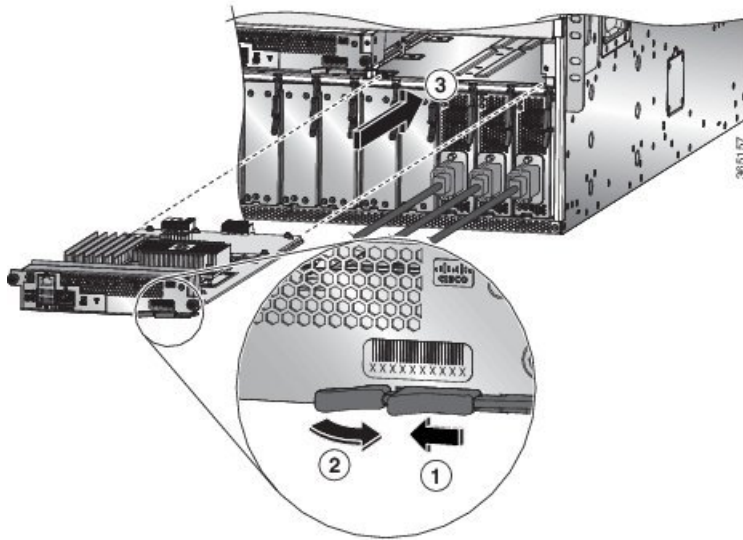

1	Slide the middle handle toward the end of the ejector lever.	3	Slide the back end of the card into the open route processor slot.
2	Rotate the ejector lever away from the card.		

- d) Rotate the lever all the way to the front of the chassis until it locks in place with a click.
Make sure that the other end of the lever engages behind the front of the slot so that the card fully seats onto the connectors on the midplane.
- e) Screw in the two captive screws to secure the card to the chassis. Tighten the screws to 8 in-lb (0.9 N·m) of torque.
- f) Attach the following cables to the card:
 - Console cable—Attach to the Console port.
 - Management cable—Attach to the Management Ethernet port.
- g) Verify that the route processor card LEDs turn on and appear as follows:
 - The Status (STS) LED blinks in amber color, then turns to solid amber color, and later turns to green color.
 - The Active (ACT) LED is amber or green.

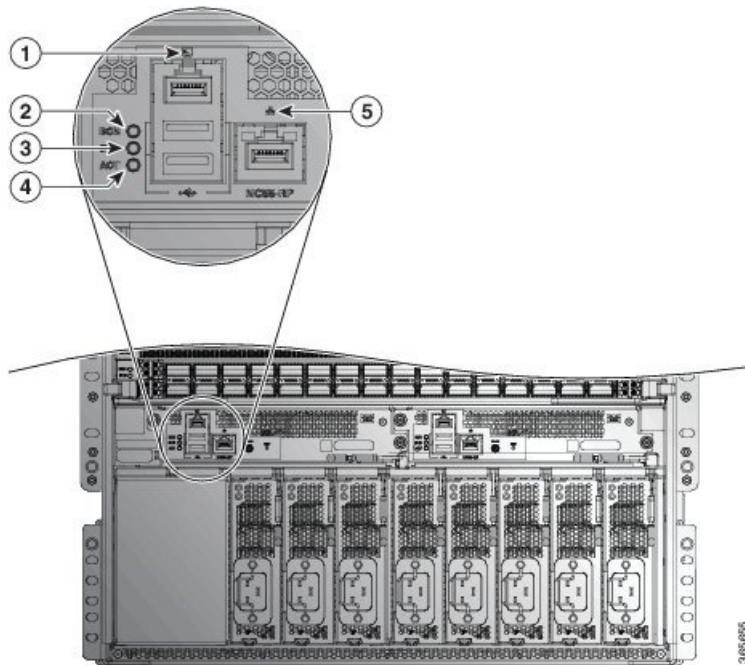

Replace a System Controller Module

The router can operate with one or two system controller modules installed in the chassis. You can replace one system controller module while there is another one installed in the chassis.



Warning Statement 1029—Blank Faceplates and Cover Panels

Blank faceplates and cover panels serve three important functions: they prevent exposure to hazardous voltages and currents inside the chassis; they contain electromagnetic interference (EMI) that might disrupt other equipment; and they direct the flow of cooling air through the chassis. Do not operate the system unless all cards, faceplates, front covers, and rear covers are in place.



Warning Statement 1034—Backplane Voltage

Hazardous voltage or energy is present on the backplane when the system is operating. Use caution when servicing.

Watch [Replace a System Controller Module \(Video\)](#)

- Step 1** Open the packaging for the new system controller module and inspect the module for damage. If the module is damaged, alert the Technical Assistance Center (TAC).

Step 2 If you are installing the module in an empty slot, remove the blank module that is already in that slot by unscrewing its captive screw and pulling it out of the slot. Go to Step 4.

Step 3 If you are replacing a module that is currently in the chassis, remove the existing module from the chassis by following these steps:

- a) Run the **hw-module location <loc> shutdown** command in admin EXEC mode, to gracefully shut down the card.
- b) Unscrew the two captive screws (one on each side of the module) until the screws are no longer in contact with the chassis.
- c) Slide and hold the middle handle on the ejector lever toward the end of the lever.
- d) Rotate the ejector lever away from the front of the module.

As you rotate the lever, the module unseats from the midplane and moves slightly forward.

- e) Use the lever to pull the module a couple of inches (about 5 cm) out of the slot.
- f) Use one hand to hold the front of the module, place your other hand under the module to support its weight, pull the module out of the chassis, and set it on an antistatic surface or inside an antistatic bag.

Step 4 To install the new module, follow these steps:

- a) Slide and hold the middle handle on the ejector lever toward the end of the lever (see the following figure).

Figure 70: Removing a System Controller Module from a Chassis

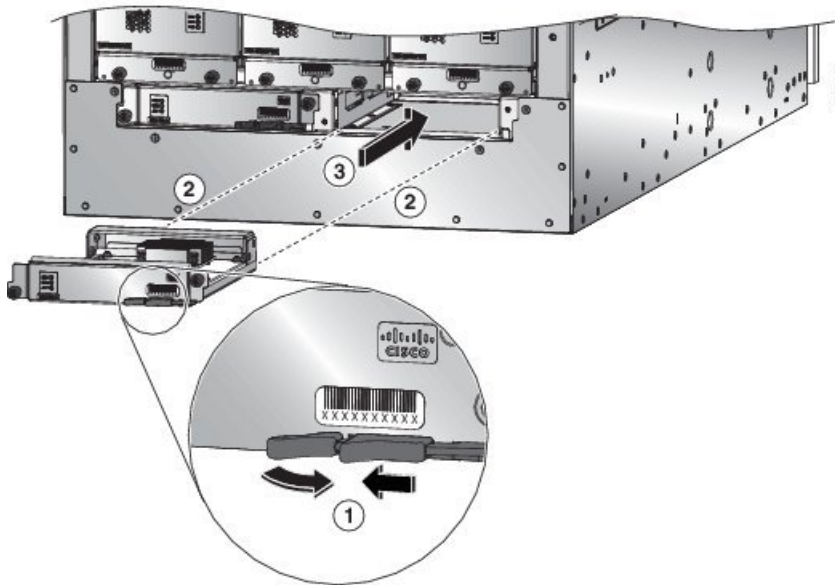

1	Slide the middle handle on the ejector lever to the end of the lever and rotate the lever away from the module.	3	Slide the module all the way into the chassis.
2	Align the back of the module to the open slot in the chassis.		

- b) Hold the front of the module with one hand and place your other hand under the module to support it.
- c) Align the back of the module to the guides in the open controller slot and slide the module all the way into the slot.

The module stops when its front is about 0.25 inches (0.6 cm) outside the front of the chassis.

- d) Rotate the ejector lever all the way to the front of the chassis until it locks in place with a click.
The module is fully seated on the midplane.
- e) Screw in the two captive screws to secure the module to the chassis. Tighten each of these screws to 8 in-lb (0.9 N·m) of torque.
- f) Verify that the Status (STS) LED blinks in amber color, turns to solid amber color, and later turns to green color, and the Active (ACT) LED is amber or green.

Installing and Removing a Blank Line Card

When a line card slot is not in use, fill the empty slot with a blank line card to allow the router to conform to electromagnetic interference (EMI) emissions requirements and to allow proper airflow across the line cards.

Figure 71: Blank Line Card (NC55-5500-LC-BLNK)

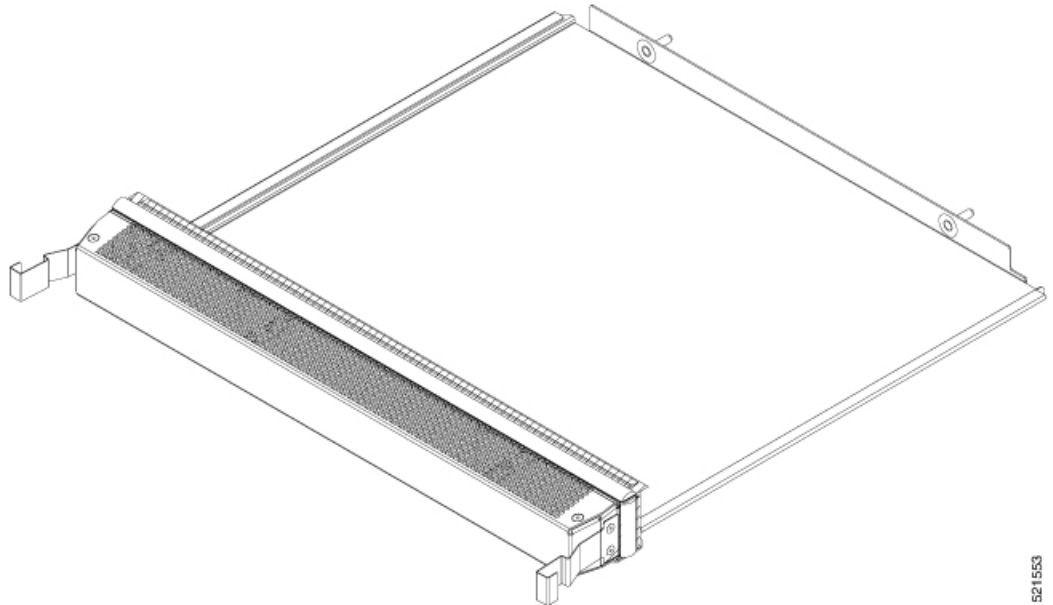

521553

Installing a Blank Line Card

This procedure shows how to insert a blank line card into a line card slot:

- Step 1** Hold the front of the blank line card with one hand and place your other hand under it.
- Step 2** Align the back of the blank line card with the guides in the open line card slot and slide it all the way into the slot. The two latches on the sides of the blank line card should be locked onto the brackets on the side of the chassis.

To prevent jamming the blank line card between the upper and the lower edges of the slot, make certain that you position it correctly, as shown in this illustration.

Figure 72: Inserting a Blank Line Card

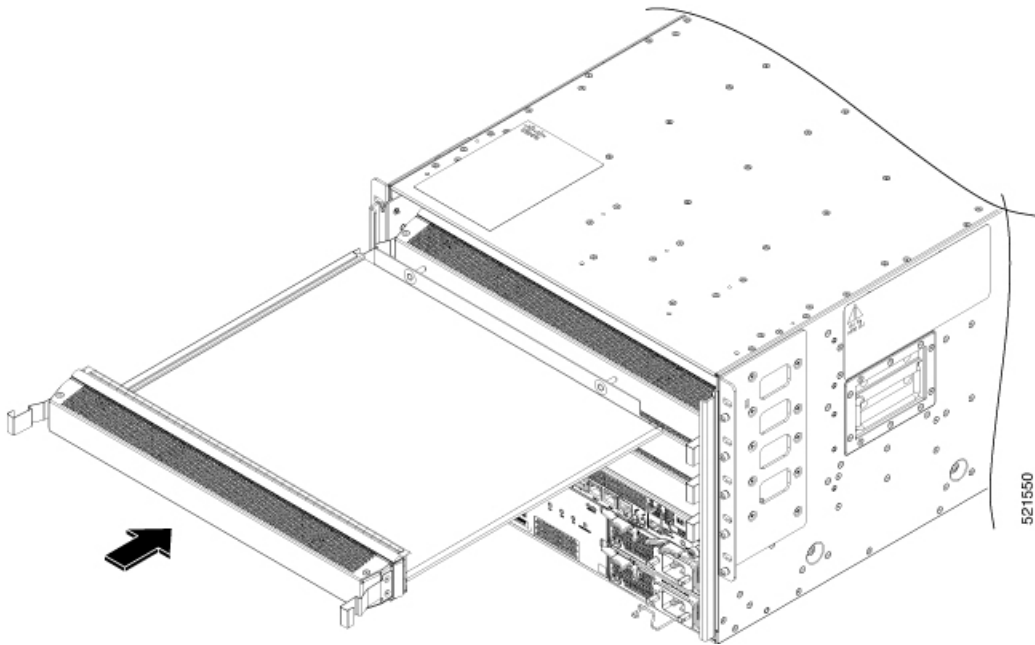

Note The latches are stiff and may require extra force to fully engage with the brackets on the sides of the chassis.

Removing a Blank Line Card

This procedure shows how to remove a blank line card from a line card slot:

- Step 1** Press the two latches on the sides of a blank line card using your forefingers so that it is unlocked from the brackets on the side of the chassis. Gently pull it out a bit.

Figure 73: Hold the Latches on the sides

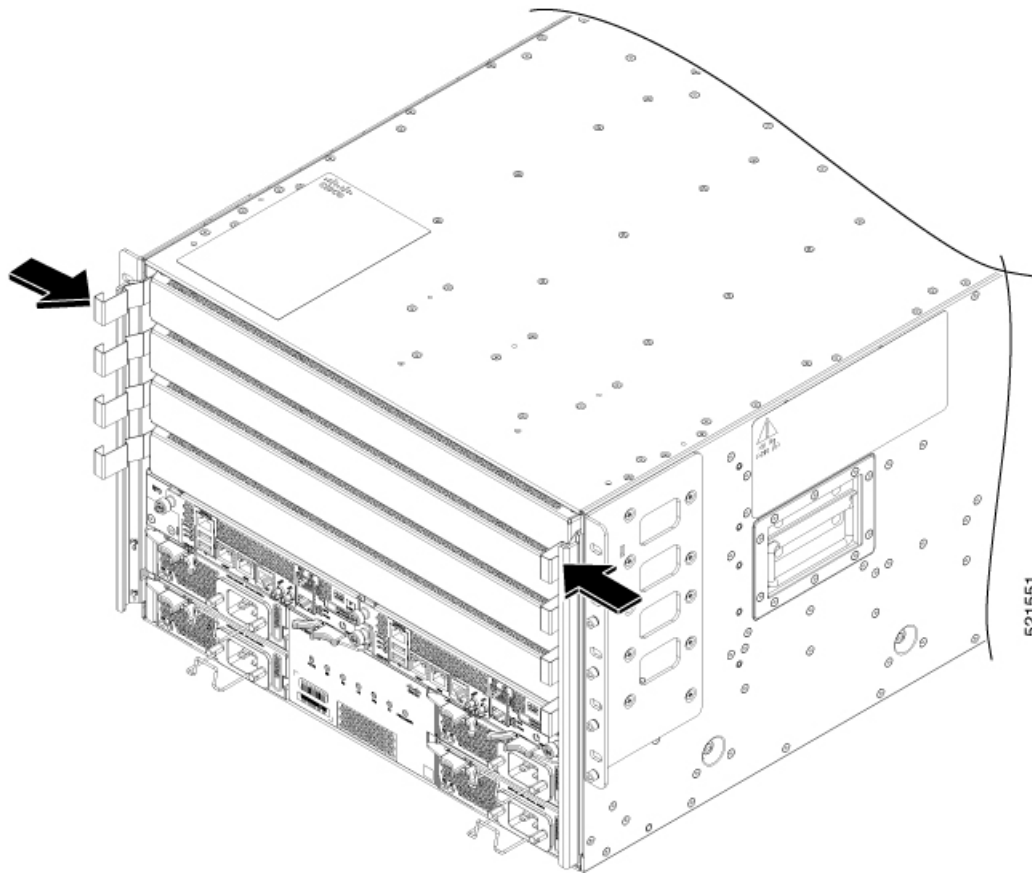

Step 2 Hold the blank line card using both hands, and pull it completely out of the chassis slot.

Figure 74: Removing the Blank Line Card

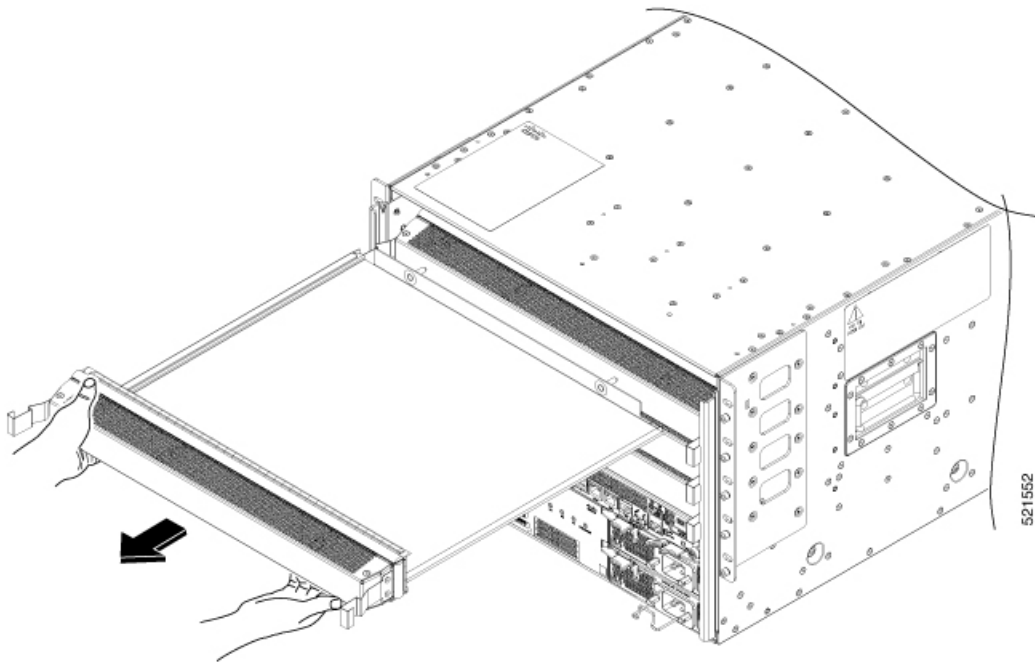

Note The latches are stiff and may require extra force to fully disengage from the brackets on the sides of the chassis.

Replace a Line Card

The router can operate with one or more line cards installed in the chassis. If there is at least one line card installed and operating in the chassis, you can replace another line card or install a new line card in an empty line card slot.



Warning Statement 1029—Blank Faceplates and Cover Panels

Blank faceplates and cover panels serve three important functions: they prevent exposure to hazardous voltages and currents inside the chassis; they contain electromagnetic interference (EMI) that might disrupt other equipment; and they direct the flow of cooling air through the chassis. Do not operate the system unless all cards, faceplates, front covers, and rear covers are in place.



Warning Statement 1034—Backplane Voltage

Hazardous voltage or energy is present on the backplane when the system is operating. Use caution when servicing



Warning Statement 1051—Laser Radiation

Invisible laser radiation may be emitted from disconnected fibers or connectors. Do not stare into beams or view directly with optical instruments.

Watch [Replace a Line Card \(Video\)](#)

Step 1 Open the packaging for the new line card and inspect the module for damage.

If the module is damaged, contact the Technical Assistance Center (TAC).

Step 2 If you are replacing a module that is currently in the chassis, remove the existing module from the chassis by following these steps:

- a) Disconnect and label each of the interface cables from the module.
- b) Run the **hw-module location <loc> shutdown** command in admin EXEC mode, which gracefully shuts down the line card. Alternatively, you can execute the **hw-module shut location <loc>** command in XR config mode.
- c) Verify that the line card Status (STS) LED for the slot that you specified turns off. Also, you can verify that the card is in powered off state running the **show platform** command to verify the status of the card to be POWERED_OFF.
- d) Rotate each of the two ejector levers away from the center of the chassis (see the following figure).

Figure 75: Remove a Line Card from the Chassis

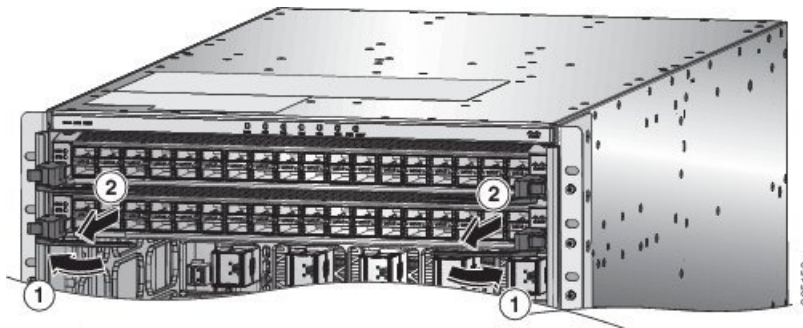

1	Rotate the ejector handle on each end of the module away from the center of the chassis until they no longer hold onto the mounting bracket.	2	Pull each ejector handle to remove the module part way from the chassis.
---	--	---	--

The levers unlock themselves from the brackets on the side of the chassis.

- e) Use the levers to pull the module a couple of inches (about 5 cm) from the chassis.
- f) Use one hand to hold the front of the module, place your other hand under the module to support its weight, pull it out of the chassis, and set it on an antistatic surface or inside an antistatic bag.

Step 3 To install the new module, follow these steps:

- a) Rotate the end of each of the two ejector levers away from the center of the chassis.
- b) Hold the front of the module with one hand and place your other hand under the module to support its weight.
- c) Align the back of the module to the guides in the open line card slot and slide the module all the way into the slot (see the following figure).

The module stops when its front is about 0.25 inches (0.6 cm) outside the front of the chassis. The two levers move part way to the front of the chassis.

Figure 76: Insert a Line Card into the Chassis

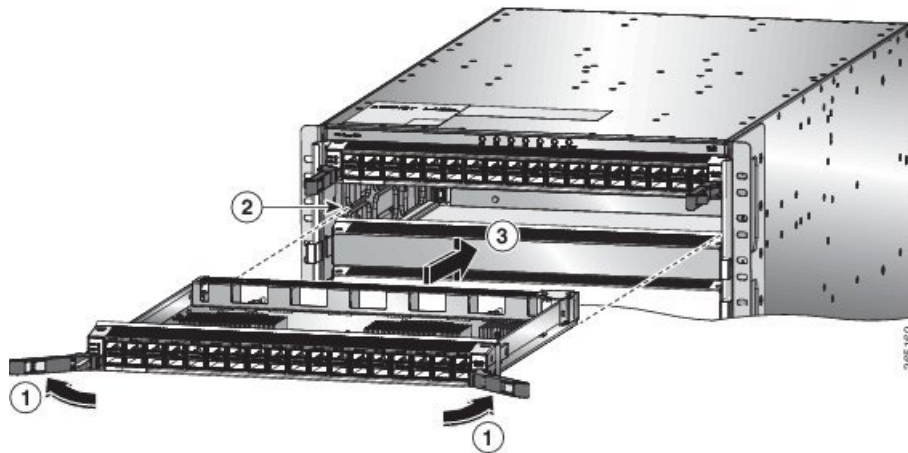

1	Rotate the ejector handle on each end of the module away from the center of the chassis.	3	Slide the module all the way into the slot.
2	Align the bottom of the back of the module with tracks on either side of the slot.		

- d) Rotate the ends of the two levers toward the center of the chassis.

When the levers point straight out from the chassis, their other ends should be locked onto the brackets on the side of the chassis.

As you rotate the levers, the front of the module moves all the way to the front of the chassis and the module fully seats on the midplane of the chassis.

- e) Attach each interface cable to the appropriate port on the line card. Use the label on each cable to determine which port each cable attaches to.
- f) Login to the System admin config mode. Power on the card gracefully using the **no hw-module shutdown location <loc>** command. Alternatively, you can execute the **hw-module unshut location <loc>** or **no hw-module shut location <loc>** command in XR config mode.
- g) Verify that the line card LEDs turn on and appear as follows:
- The Status (STS) LED blinks in amber color, then turns to solid amber color, and later turns to green color.
 - For each connected port, the port LED turns on and becomes green or amber.

Installing and Removing Modular Port Adapters

The following sections describe how to install or remove MPA:

Handling Modular Port Adapters

Each modular port adapter (MPA) circuit board is mounted to a metal carrier and is sensitive to electrostatic discharge (ESD) damage.



Caution Always handle the MPA by the carrier edges and handle; never touch the MPA components or connector pins (See the figure below).

When a bay is not in use, a blank MPA Slot Filler must fill the empty bay to allow the router or switch to conform to electromagnetic interference (EMI) emissions requirements and to allow proper airflow across the installed modules. If you plan to install a MPA in a bay that is not in use, you must first remove the blank.

Figure 77: Handling a Modular Port Adapter

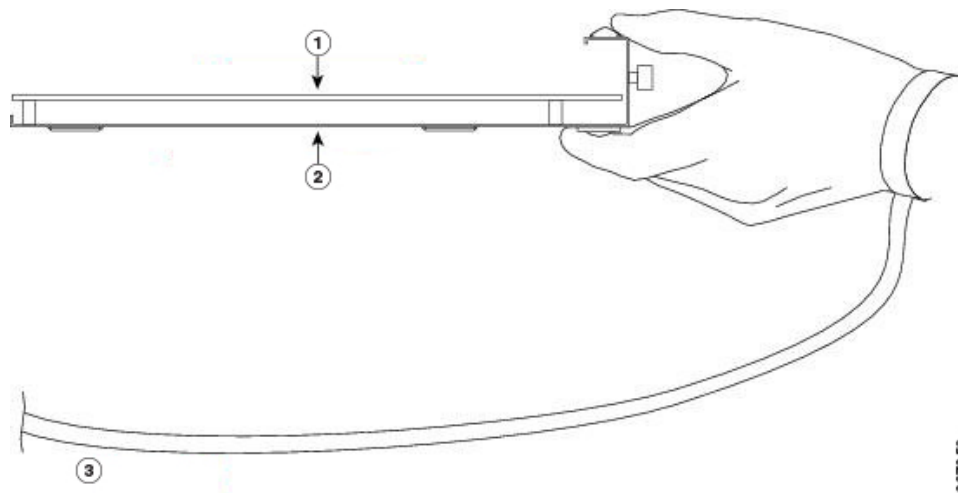

1	Printed Circuit Board	2	Metal Carrier
3	Grounding Strap		

Online Insertion and Removal



Caution Cisco IOS XR Software 6.6.1 and later releases support online insertion and removal (OIR) of Cisco NCS 5500 series modular port adapters (MPAs).

Cisco NCS 5500 series modular port adapters (MPAs) support online insertion and removal (OIR). Modular port adapters (MPAs) can be inserted or removed independently from the modular line card (MLC). OIR of a MLC with installed modular port adapters (MPAs) is also supported.

Limitation:

- During online insertion and removal of MPA on the Cisco ASR 9000 Series router, the field-programmable gate array (FPGA) turns off and the physical interface (PHY) is unavailable to inhibit the clock. As a result, you will observe a SyncE jump of 80 - 120 ns on downstream nodes.

Modular port adapters (MPAs) support the following types of OIR:

- Soft OIR

Soft OIR uses the IOS XR **hw-module subslot** *rack/slot/subslot* **reload**, **hw-module subslot** *rack/slot/subslot* **shutdown**, and **no hw-module subslot** *rack/slot/subslot* **shutdown** commands to complete online insertion and removal.

- Managed OIR

A managed online insertion and removal of Modular port adapters (MPAs) is comprised of the following steps:

- Shut down the MPA with the **hw-module subslot** *rack/slot/subslot* **shutdown** command.
- Confirm that the LEDs have gone from green to off.
- Execute the **do show platform** command to verify that the MPA to be removed is in the disabled state.
- Physically remove the MPA to be replaced.
- Physically insert the replacement MPA. After inserting the MPA in the slot, tighten the MPA screw located on the right side within 10 seconds. Ensure that you first tighten the right screw and then the left.



Note Tighten the captive screws on the MPA within 10 seconds. Otherwise, the MPA shuts down and moves to **Disabled** state. To recover the MPA, tighten both the captive screws and then execute the **hw-module subslot** *rack/slot/subslot* **reload** command.

- Return the MPA to the up state with the **no hw-module subslot** *rack/slot/subslot* **shutdown** command.

- Hard OIR

You can perform the OIR in a running system, by performing the following steps, without executing any commands:

- Loosen the right ejector screw.
- Loosen the left ejector screw.
- Remove and replace the MPA.

Modular Port Adapter Installation and Removal

This section provides step-by-step instructions for removing and installing a modular port adapter (MPA) in a NC55-MOD-A-S and NC55-MOD-A-SE-S modular line card (MLC).



Note After you remove the MPA from the slot, wait for 60 seconds before you reinsert the MPA.



Note After you unscrew both ejector screws, wait for 15 seconds before removing MPA from the slot.



Warning During this procedure, wear grounding wrist straps to avoid ESD damage to the card. Do not directly touch the backplane with your hand or any metal tool, or you could shock yourself. Statement 94

To remove and install a MPA, do the following:

1. To insert the MPA, locate the guide rails inside the MLC that hold the MPA in place. They are at the bottom left and bottom right of the MPA slot and are recessed about an inch.
2. Carefully slide the MPA all the way in the MLC until the MPA is firmly seated in the MPA interface connector. When fully seated, the MPA might be slightly behind the faceplate.



Note The MPA will slide easily into the slot if it is properly aligned on the tracks. If the MPA does not slide easily, do NOT force it. Remove the MPA and reposition it, paying close attention to engaging it on the tracks. Push the MPA inside the slot until you hear a click. Continue to push the MPA further until you hear a second click. The MPA is fully seated only after the second click is heard.

3. After the MPA is properly seated, use a number 2 Phillips screwdriver to tighten the captive screws on the MPA. Ensure that you first tighten the right screw and then the left.



Note Tighten the captive screws on the MPA within 10 seconds. Otherwise, the MPA shuts down and moves to **Disabled** state. To recover the MPA, tighten both the captive screws and then execute the **hw-module subslot rack/slot/subslot reload** command.



Note Avoid over torquing the MPA captive screws when installing the MPA. Tighten the captive screws on the MPA to a torque of 6 +/-0.5 inch-pound.

4. To remove the MPA from the MLC, use a number 2 Phillips screwdriver to loosen the captive screws on the MPA. Ensure that you first loosen the right screw and then the left.
5. Grasp the MPA and pull the MPA from the MLC. (You have already disconnected the cables from the MPA.)

Replace a Fan Tray

You can remove a fan tray to either replace it with another fan tray or to replace a fabric cards located behind it.

The router uses three fan trays but it can operate with two fan trays while you replace one or remove one to replace one of the fabric cards behind the fan tray. When you remove one fan tray, the other fan trays speed up their fans to maintain the designed airflow.



Note If you cannot replace a fan tray within three minutes, we recommend that you leave it in the chassis until you are ready to replace it.



Note If you remove more than one fan tray at a time during operations, the router allows up to two minutes of operations before shutting down unless you replace extra missing fan trays within that time. If the router senses an over temperature condition when multiple fan trays are removed, the shutdown can occur in less than two minutes.



Note In the case of a single fan tray failure, for the Cisco NCS 5500 series modular routers to continue operations, the maximum permissible temperature is 30°C, at an altitude of 1800 meters.

To replace a fan tray, you must perform the following functions:

1. Remove the fan tray. For more information, see [Remove Fan Tray, on page 146](#).
2. If you need to replace a fabric card behind the removed fan tray, see [Replace Fabric Card, on page 149](#).
3. Install a fan tray as explained in [Install Fan Tray, on page 147](#).

Watch [Replace a Fan Tray \(Video\)](#)

Remove Fan Tray

Remove only one fan tray at a time during router operations. If you remove more than one fan tray at a time, the router will shut down within two minutes unless you replace the extra fan trays that you removed within that time.

-
- Step 1** Unscrew the four captive screws on the front of the fan tray until each screw is free of the chassis (see the following figure).

Figure 78: Remove Fan Tray from the Chassis

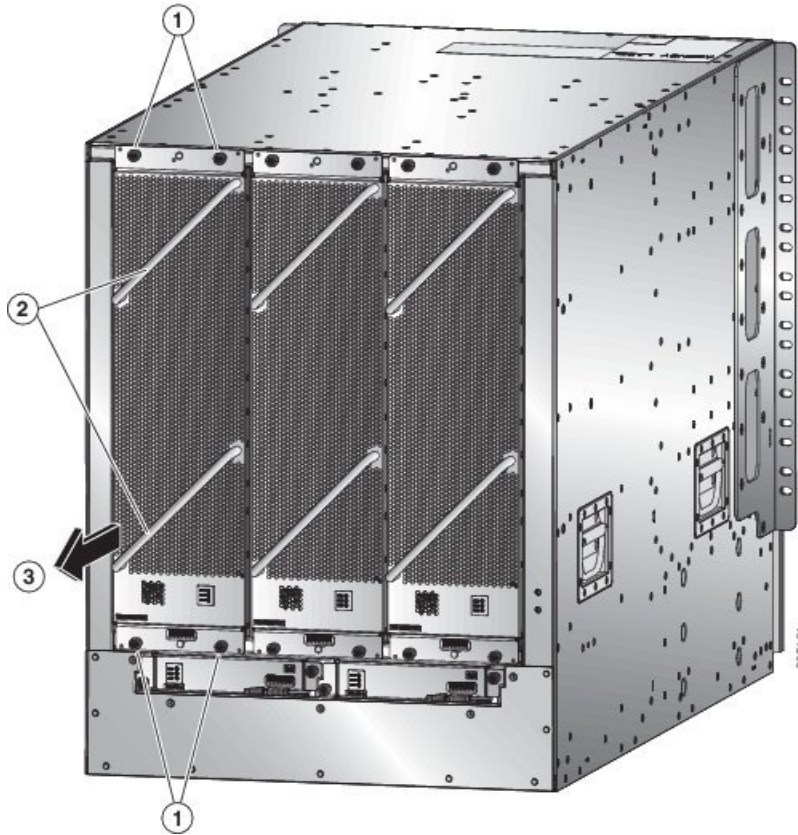

1	Unscrew four captive screws (two at the top of the module and two at the bottom of the module).	3	Pull on the fan tray to slide it out of the chassis. Set the fan tray on an antistatic surface.
2	Hold the two fan tray handles with your two hands.		

Step 2 Hold both handles on the front of the fan tray with both of your hands and pull the fan tray out of the slot.

Step 3 Set the fan tray on antistatic material or inside an antistatic bag.

Install Fan Tray

Before you begin

- Fan tray slot is open in the chassis.
- Fan tray is available for installation.
- If you are replacing a fabric card behind the open fan tray slot, ensure that the fabric card replacement operation is completed.

Step 1 Use both of your hands to hold the two handles on the front of the fan tray that you are installing.

Figure 79: Install Fan Tray in Chassis

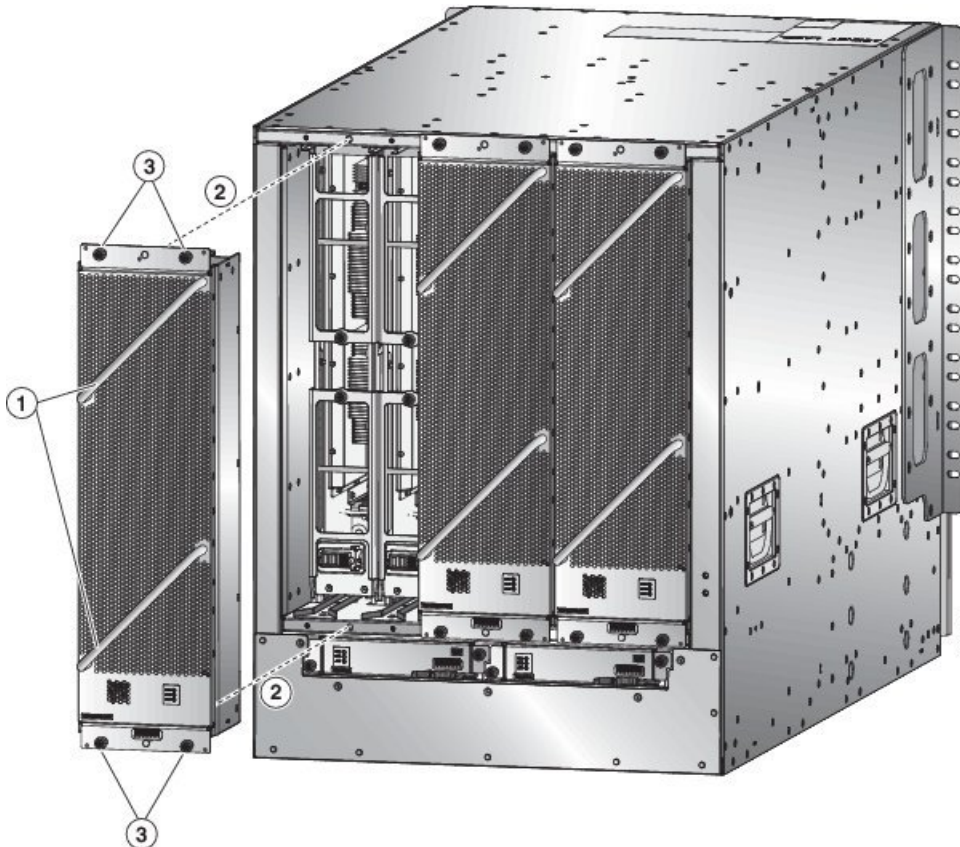

1	Hold the two fan tray handles with your two hands.	3	Screw in four captive screws and tighten each screw to 8 in-lb (0.9 N·m) of torque.
2	Position the back of the fan tray to the open fan tray slot. The pins on the top and bottom of the fan tray should align to holes in the chassis and the two sets of rails on the top of the fan tray should align to two sets of tracks on the top of the open slot. Slide the fan tray all the way into the slot.		

Step 2 Position the fan tray with its rear (the side with the electrical connectors) at the opening for the fan tray slot in the chassis.

Step 3 Align the two tracks on the top of the fan tray with the two sets of rails at the top of the open fan tray slot in the chassis.

Step 4 Slide the fan tray all the way into the slot until the front of the fan tray touches the chassis.

Make sure that the four captive screws on the front of the fan tray align with the four screw holes in the chassis.

Step 5 Screw in the four captive screws to secure the fan tray to the chassis. Tighten the screws to 8 in-lb (0.9 N·m) of torque.

Step 6 Verify that the fan tray STATUS LED turns on and becomes green.

Replace Fabric Card

The router uses either three or six fabric cards but you can replace a fabric card while others are operating. To replace a fabric card, you must do each of the following:

- Shutdown the fabric card being replaced.
- Remove the fan tray covering the fabric card in the chassis.
- Remove the fabric card.
- Install the new fabric card.
- Reinstall the fan tray over the fabric card.
- Activate the fabric card.

To maintain the designed airflow while you remove the fan tray, the fans in the other fan trays increase their speed. During operations, it is recommended that you remove only one fan tray at a time and reinstall that fan tray within three minutes to avoid the possibility of having the router overheat and shut down. If you remove more than one fan tray at a time, the router will shut down if you do not reinstall the extra missing fan trays within two minutes (the shutdown can occur earlier if the router over heats).



Note If the router does not have all of the fabric slots filled, fill them as indicated in the following table and insert blank filler plates in the open slots. If you do not fill the recommended slots with fabric cards, some of the fans will not power up.

Table 19: Fabric Card Slots to Fill

Number of Fabric cards	Slots to be Filled
1 (Not allowed)	N.A.
2 (Not recommended)	N.A.
3 (Minimum recommended number)	Labeled as FC1, FC3, and FC5
4	Labeled as FC1, FC2, FC3, and FC5
5	Labeled as FC0, FC1, FC2, FC3, and FC5, or Labeled as FC1, FC2, FC3, FC4, and FC5
6 (Fully populated)	Labeled as FC0, FC1, FC2, FC3, FC4, and FC5



Note NCS 5508 and NCS 5516 chassis requires fully populated second generation fabric cards for fans to perform at 100%.

To replace a fabric card, you must perform these operations, which are explained in the topics that follow:

1. Remove the fan tray that covers the fabric card that you are replacing.
2. Shut down and remove the fabric card.
3. Install the new fabric card.
4. Install the fan tray over the new fabric card.

Watch [Replace Fabric Card \(Video\)](#)

Removing a Fabric Card

Before you begin

- You must wear an electrostatic discharge (ESD) wrist strap or other ESD protective device while handling modules.
- Prepare an antistatic surface or packing materials for each module that you remove from the chassis.



Note After executing the command in sysadmin config mode, **commit** the command for the configuration to take effect.

Step 1 If you are replacing a fabric card, open the packaging for the new module and inspect it for damage.

If the module is damaged, alert the Technical Assistance Center (TAC) and stop this replacement process until you have an undamaged module to install.

Step 2 To prevent loss of packets during operations, shut down the fabric card as follows:

- a) Shut the fabric control plane using the **controller fabric plane <plane-id> shutdown** command in the sysadmin config mode.

There are six planes and the value of the *<plane-id>* is between 0 to 5.

When you are replacing the card, shutdown the corresponding fabric plane of the card. For example, when you are replacing the card in slot 0 (0/FC0), shut down fabric plane 0.

- b) Run the **hw-module shutdown location <loc>** command in the sysadmin config mode. Alternatively, you can execute the **hw-module shut location <loc>** command in XR config mode.
- c) Verify that the fabric (FAB/FC) LED for the slot that you specified turns off, on the fan tray. Also, you can verify that the card is in powered off state running the **show platform** command in the sysadmin mode to verify the status of the card to be POWERED_OFF.

Step 3 Remove the fan tray that covers the fabric card by following these steps:

- a) Unscrew the four captive screws on the front of the fan tray (one on each corner of the front of the fan tray) until each screw is free of the chassis (see Callout 1 in the following figure).

Figure 80: Removing a Fan Tray from the Chassis

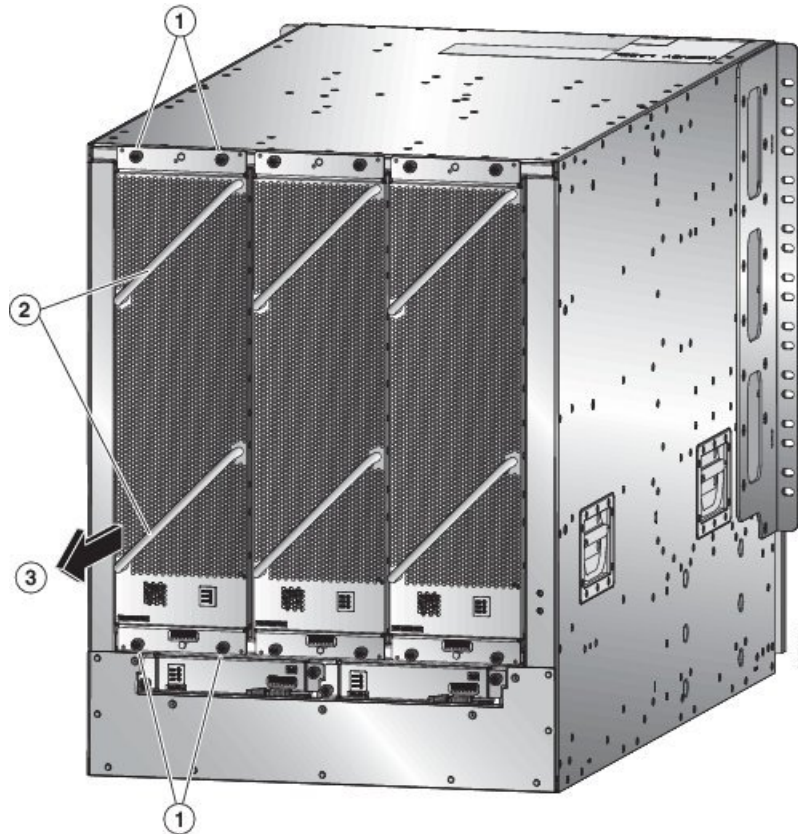

1	Unscrew four captive screws (two at the top of the module and two at the bottom of the module).	3	Pull on the fan tray to slide it out of the chassis. Set the fan tray on an antistatic surface.
2	Hold the two fan tray handles with your two hands.		

- b) Hold both handles on the front of the fan tray with both of your hands and pull the fan tray out of the slot.
- c) Set the fan tray on antistatic material or inside an antistatic bag.

Step 4

Remove the fabric card that you are replacing by following these steps:

- a) Unscrew the screw on the center of each of the two handles on the fabric card (see Callout 1 in the following figure).

Figure 81: Unlocking a Fabric Card from its Slot in the Chassis

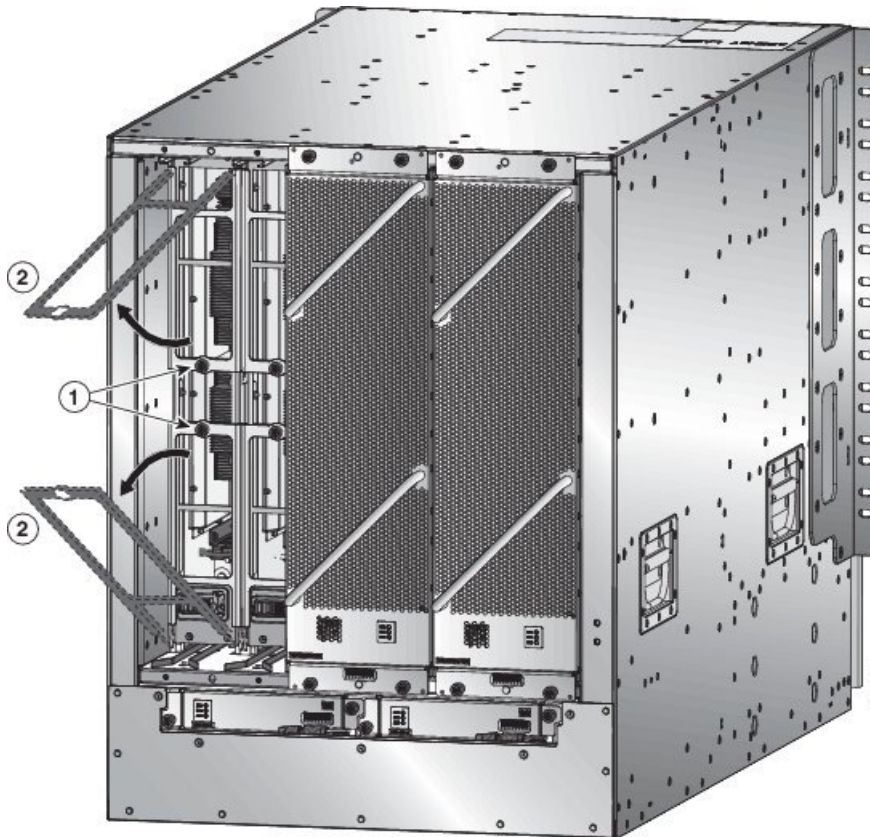

1	Unscrew two captive screws (one on each ejector handle).	2	Rotate both ejector handles away from the front of the fabric card.
---	--	---	---

- b) Rotate the two handles at least 30 degrees so that the other end of each handle no longer holds the module in the slot (see Callout 2 in the previous figure).
- c) With each of the two handles in your two hands, pull the module a couple of inches (about 5 cm) out of the slot (see the following figure).

Figure 82: Removing a Fabric Card from the Chassis

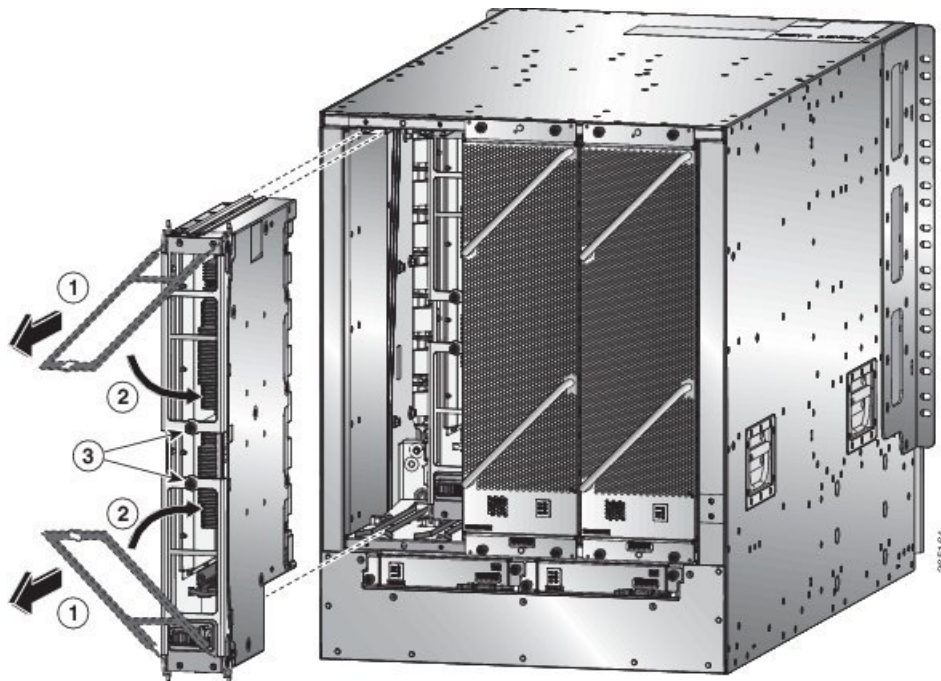

1	Pull on both handles to partially remove the fabric card from the chassis	3	Screw in the two captive screws (one on each handle) to the module. Tighten each of these screws to 8 in-lb (0.9 N·m) of torque.
2	Rotate both ejector handles to the front of the module.		

- d) Rotate both handles back to the front of the module until they click in place. Fasten each handle to the module using the captive screw on the back of the handle. Tighten the screw to 8 in-lb (0.9 N·m) of torque (see callouts 2 and 3 in the previous figure).
- e) Place one hand under the fabric card to support its weight, place your other hand on the front of the module, and slide the module out of the slot.
- f) Rotate the module 90 degrees and lay it flat on an antistatic surface or in an antistatic bag.

- Step 5** Replace the card, and login to the System admin config mode. Power on the card gracefully using the **no hw-module shutdown location <loc>** command. Alternatively, you can execute the **hw-module unshut location <loc>** or **no hw-module shut location <loc>** command in XR config mode.
- Step 6** Verify that the card shows as operational in XR VM and System Admin VM using the **show platform** command in the sysadmin mode. From the System admin config mode, enable the plane using the **no controller fabric plane <plane-id> shutdown** command.
- Step 7** Verify if the plane displays “UP UP” using the **show controllers fabric plane all** command in the sysadmin mode.

Restrictions for using XR plane hw-module configuration

These are the restrictions for using XR plane hw-module configuration:

- The XR plane hw-module config is supported only in Single-SDR system (SOST). In Multi-SDR, the configuration gets rejected with an appropriate error message.
- In XR plane, the show running-config shows only the unshut configuration if it is explicitly configured. To remove the unshut configuration execute the no hw-module unshut location <loc> command in XR config mode.
- When the hw-module is configured as unshut in XR, the admin exec hw-module operation like reload, shutdown, offline and so on are allowed. Similarly, when the hw-module is shut down through admin exec command, unshut config from XR will not bring the card out of shut down.
- The XR plane hw-module config overwrites the sysadmin hw-module config for the same location, if any.
- Although the XR side hw-module config are synced to sysadmin, the show running-config in sysadmin shows only the shut config. The unshut config will not explicitly shown in sysadmin, as the unshut is treated as no hw-module shut in sysadmin.
- The sysadmin hw-module config is not synced to an XR plane, so the show running-config in XR does not show any hw-module config that are directly configured from sysadmin plane.
- When the XR plane is used for hw-module shut or hw-module unshut config, the sysadmin plane should not be used to modify the same hw-module config.
- When XR RP VM is deleted, the shutdown config replicated to the sysadmin remains. Even if the XR VM is created again, the shutdown config presented earlier cannot be recovered again in the XR side.

Install a Fabric Card

- Step 1** Place one hand on the front of the module and turn the module 90 degrees so that the electrical connectors are on the bottom.
- Step 2** Unscrew the two captive screws (one on each ejector handle) and rotate the ejector handles away from the chassis (see Callouts 1 and 2 in the following figure). Be sure that the locking posts on the top and bottom of the chassis (see Callout 3) rotate into the module so that the module can slide fully into the slot.

Figure 83: Installing a Fabric Card in a Chassis

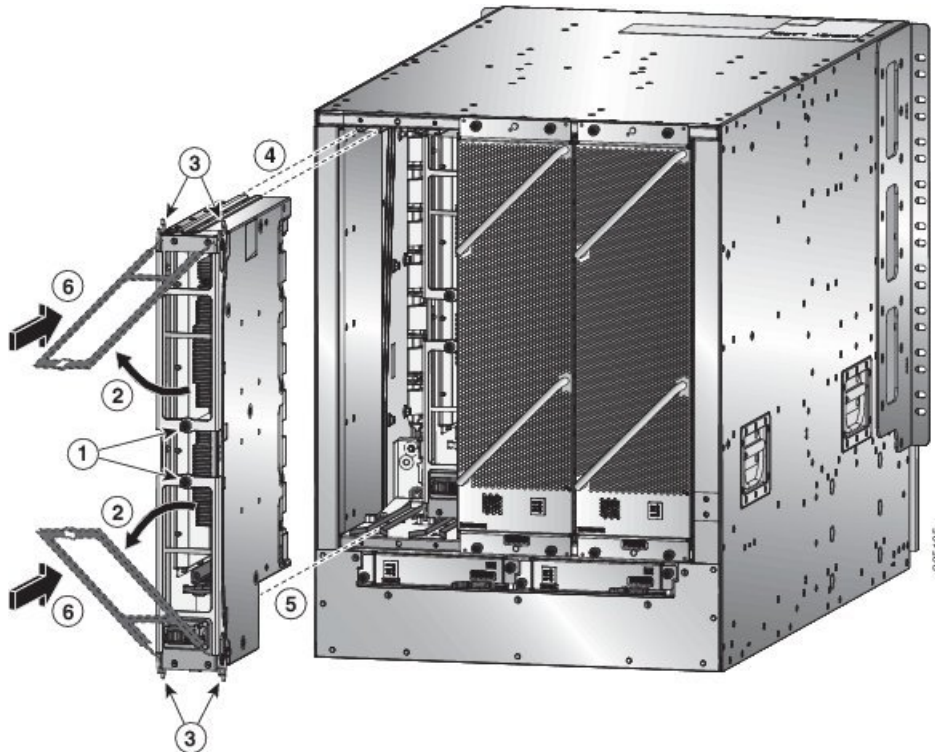

1	Unscrew two captive screws (one on each ejector handle).	4	Align the rails on the top of the module to the track on the top of the open slot.
2	Rotate both ejector handles away from the front of the module.	5	Align the bottom of the module so that it slides into the tracks on the bottom of the open slot.
3	Be sure that the locking posts fully rotate down into the module	6	Slide the module all the way into the slot.

- Step 3** Fit the guide rails on the top of the module into the track on the top of the slot and make sure that the guide bar on the bottom of the module goes into the module guide at the bottom of the slot.
- Step 4** Slide the module all the way into the slot.
- Step 5** Rotate both ejector levers to the front of the chassis and be sure that the module is locked to the top and bottom of the slot.
- Step 6** Screw in the captive screw on each of the two levers so that each lever is locked in place on the module. Tighten each screw to 8 in-lb (0.9 N·m) of torque.
- Step 7** Reinstall the fan module over the replaced fabric card by following these steps:
 - a) Use both of your hands to hold the two handles on the front of the fan tray that you are installing.

Figure 84: Install Fan Tray in Chassis

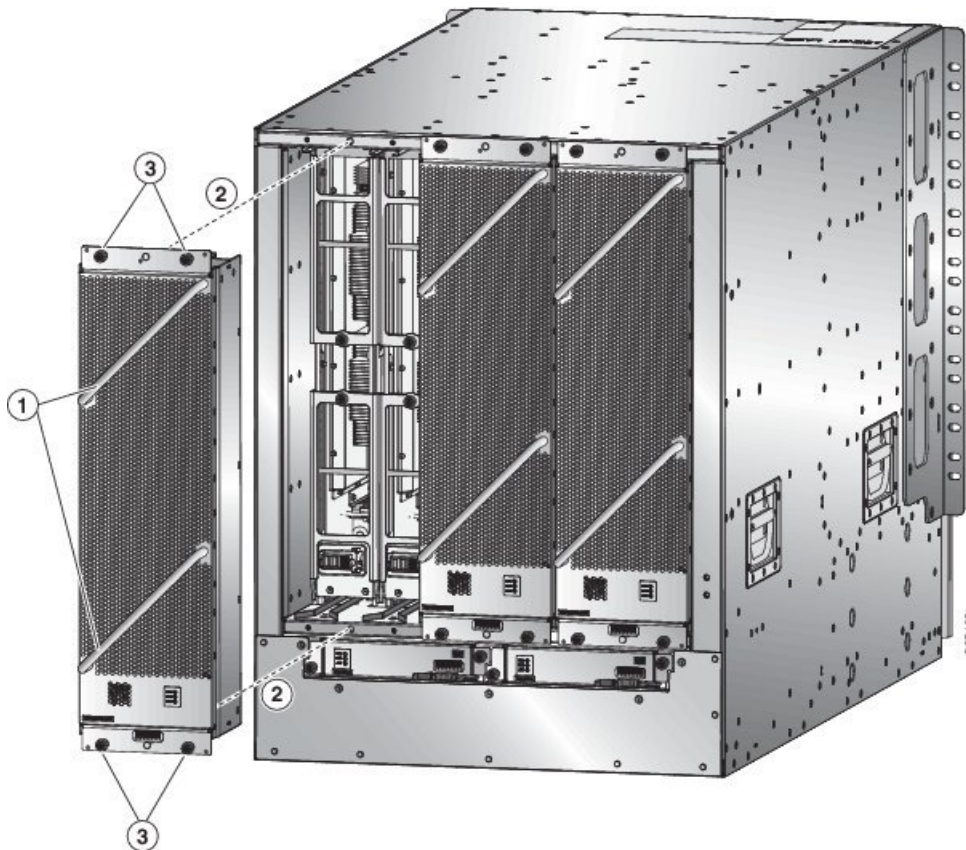

1	Hold the two fan tray handles with your two hands.	3	Screw in four captive screws and tighten each screw to 8 in-lb (0.9 N·m) of torque.
2	Position the back of the fan tray to the open fan tray slot. The pins on the top and bottom of the fan tray should align to holes in the chassis and the two sets of rails on the top of the fan tray should align to two sets of tracks on the top of the open slot. Slide the fan tray all the way into the slot.		

- b) Position the fan tray with its rear (the side with the electrical connectors) at the opening for the fan tray slot in the chassis.
- c) Align the two tracks on the top of the fan tray with the two sets of rails at the top of the open fan tray slot in the chassis.
- d) Slide the fan tray all the way into the slot until the front of the fan tray touches the chassis.
Make sure that the four captive screws on the front of the fan tray align with the four screw holes in the chassis.
- e) Screw in the four captive screws to secure the fan tray to the chassis. Tighten the screws to 8 in-lb (0.9 N·m) of torque.
- f) Verify that the fan tray and fabric card STATUS LEDs (on the fan tray) turn on and become green.

Replace Power Supplies

The number of power supplies that you install depends on the power requirements of the router and the power mode that you are using. To determine the power requirements of the router, see the [Weight, Quantity and Power Consumption, on page 29](#) section.

If you are using only one power source for the combined mode or $n+1$ redundancy mode, you can install the power supplies in any of the power supply slots on the chassis. If you are using two power sources for the $n+n$ redundancy mode, you must connect the power supplies in slots 1 through 4 to one power source and the power supplies in slots 5 through 8 to the other power source. With $n+n$ redundancy mode, divide the power supplies evenly between the first half of the slots and the last half of the slots so that the amount of redundant power for the router equals the amount of available power for the router.



Note The NCS 5516 with the 3.15-kW HVAC/HVDC power supply supports $n+n$ line redundancy mode. The 3-kW AC or DC power supplies can be used for $n+1$ redundancy mode.

You can install or replace the power supplies in the router so long as all of the power supplies are the same type:

- Cisco NCS 5500 3-kW Standard AC Power Supply
- Cisco NCS 5500 3-kW Standard DC Power Supply
- Cisco NCS 5500 3.15-kW HVAC/HVDC Power Supply

Replace AC Power Supply

Before you begin

- The AC power source must be installed within reach of the power cables.
- The AC power source must meet the power specifications required by the router.
- There are one or two AC power sources available. If using $n+n$ redundancy, there must be two power sources available. Otherwise, only one power source is required.

Step 1 Open the packaging for the new 3-kW standard AC power supply and inspect the module for damage.

If the module is damaged, contact the Technical Assistance Center (TAC).

Step 2 If you are installing the module in an empty slot, remove the blank filler plate that is already in that slot by unscrewing its captive screw and pulling it out of the slot.

- If you are using the combined power mode or $n+1$ redundancy, you can use any power supply slot in the chassis.
- If you are using $n+n$ redundancy mode, you must be sure that you are inserting the power supply in a slot used for the desired power supply:
 - **NCS 5504:** The power supplies in slots 1 and 2 must be connected to one power source and the power supplies in slots 3 and 4 must be connected to the other power source

- **NCS 5508:** The power supplies in slots 1 through 4 must be connected to one power source and the power supplies in slots 5 through 8 must be connected to the other power source

Go to Step 4.

Step 3 If you are replacing a power supply that is currently in the chassis, remove the existing module from the chassis by following these steps:

- Disconnect the power cable from the power supply and verify that the output and input LEDs turn off.
- Slide the middle of the ejector lever down to the end of the lever and rotate the lever up so that its other end no longer holds onto the chassis (see the following figure).

The power supply unlocks from the chassis and moves out slightly.

Figure 85: Remove Power Supply from the Chassis

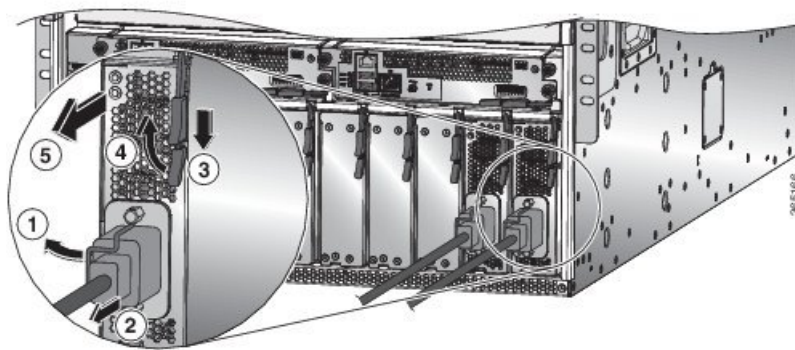

1	Rotate the cable retention clip away from the power cable plug.	4	Rotate the ejector lever away from the module.
2	Pull the power cable plug out of the receptacle.	5	Pull on the ejector lever to slide the power supply partially (2 inches [5 cm]) out of the chassis. Hold the front of the power supply and pull it all the way out of the chassis.
3	Slide and hold the middle handle on the ejector lever toward the end of the lever.		

- Pull on the lever to move the power supply about 2 inches (5 cm) out of the slot.

Caution Do not use the ejector lever to fully remove the power supply from the chassis. The ejector lever cannot support the full weight of the power supply. Using the ejector lever to fully remove the power supply from the chassis can damage the power supply and the ejector lever.

- Place one hand on the front of the power supply and your other hand under the power supply to support its weight.
- Pull the module out of the slot and place it on an antistatic surface or inside an antistatic bag.

Step 4 To install the new power supply, follow these steps:

- Ensure that the power supply is not connected to an AC power source. If it is connected to a power source, remove the power cable from the power supply and wait at least five seconds before doing the next step.
- Hold the front of the module with one hand and place your other hand under the module to support its weight.

- c) Rotate the power supply 90 degrees so that the power receptacle is positioned on the lower front side and so that the back of the power supply is oriented to slide into the open power supply slot.
- d) Slide the guide bracket that is located on the top of the power supply into the track at the top of the power supply slot. Slide the power supply all the way into the slot.

The front of the power supply will be about 0.25 inches (0.6 cm) outside the chassis.

- e) Slide the handle on the middle of the power supply ejector handle about 0.25 inches (0.6 cm) and rotate the lever away from the front of the power supply while pushing the power supply all the way into the chassis (see the following figure).

Figure 86: Installing a Power Supply in a Chassis

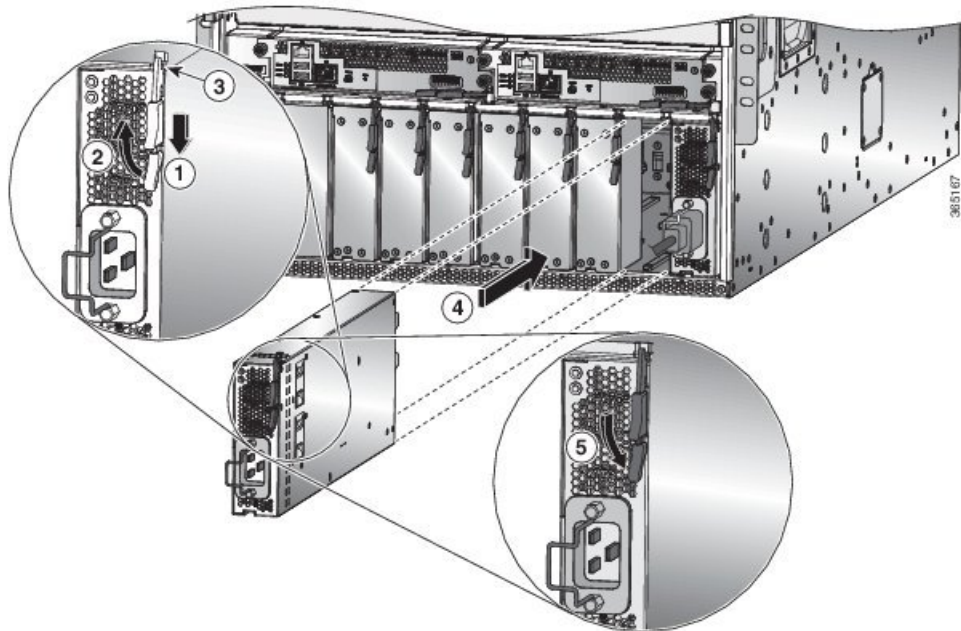

1	Slide and hold the middle handle on the ejector lever toward the end of the lever.	4	Slide the rear end of the power supply all the way into the slot and press the ejector lever toward the front of the power supply to lock it in the slot.
2	Rotate the ejector lever away from the module.	5	Rotate the lever to the front of the power supply and verify that the power supply is locked into its slot by trying to pull it out.
3	Make sure that the locking knob has rotated into the power supply and cannot prevent the power supply from sliding all the way into the chassis slot.		

- f) Rotate the ejector lever toward the front of the power supply and be sure that the other end of the lever locks into the chassis.

The lever should click when you rotate it all the way to the front of the power supply. Be sure that the power supply is fully inserted into the slot (the front of the power supply should be even with the surface of the chassis) and securely in place.

- g) Attach the power cable to the power receptacle on the power supply and rotate the power cable holder onto the plug on the cable.
 - h) Make sure that the other end of the power cable is attached to the AC power source in one of the following ways:
 - If you are using the combined power mode or the $n+1$ redundancy mode, you must connect the power cable to the same power source as used by the other power supplies in the same router.
 - If you are using the $n+n$ redundancy mode, you must connect the power cable to the same power source as used by the other power supplies in the same set of power supply slots in the chassis.
 - **NCS 5504:** The power cables for slots 1 and 2 must be connected to one power source and the power cables in slots 3 and 4 must be connected to another power source.
 - **NCS 5508:** The power cables for slots 1 through 4 must be connected to one power source and the power cables in slots 5 through 8 must be connected to another power source.
 - **NCS 5516:** The power cables for slots 1 through 5 must be connected to one power source and the power cables in slots 6 through 10 must be connected to another power source.
 - i) Verify that the OK LED turns on and eventually becomes green.
-

Replace DC Power Supply

Before you begin

- The power source must be installed within reach of the power cables.
 - The power source must meet the power specifications required by the switch.
 - There are one or two power sources available. If using $n+n$ redundancy, there must be two power sources available. Otherwise, only one power source is required.
 - Prepare an antistatic surface or antistatic bag for the power supply that you are removing.
-

Step 1 Open the packaging for the new DC power supply and inspect the module for damage.

If the module is damaged, contact the Technical Assistance Center (TAC).

Step 2 If you are installing the module in an empty slot, remove the blank filler plate that is already in that slot by unscrewing its captive screw and pulling it out of the slot. Go to Step 4.

Step 3 If you are replacing a power supply that is currently in the chassis, remove the existing module from the chassis by following these steps:

a) Turn off the power to the power supply that you are replacing as follows:

1. Shut off the power supply by setting its power switch to 0.
2. If the power supply is connected to a DC circuit, shut off the circuit at the circuit breaker.
3. Verify that the OK LED has turned off (indicates that there is no power going to the power supply).

Note The FAULT LED might be on and amber colored to indicate that the power source connection has been broken.

- b) Disconnect the power cables from the power supply as follows:
1. Remove the three screws on the safety cover for the terminal box located on the front of the power supply and pull the cover off the terminal box as shown in the following figure.
- Note** The terminal box has four slots for four power terminals (ordered as negative [-], positive [+], positive [+], and negative [-]). Each terminal has two nuts that you use to fasten a power cable to the terminal.

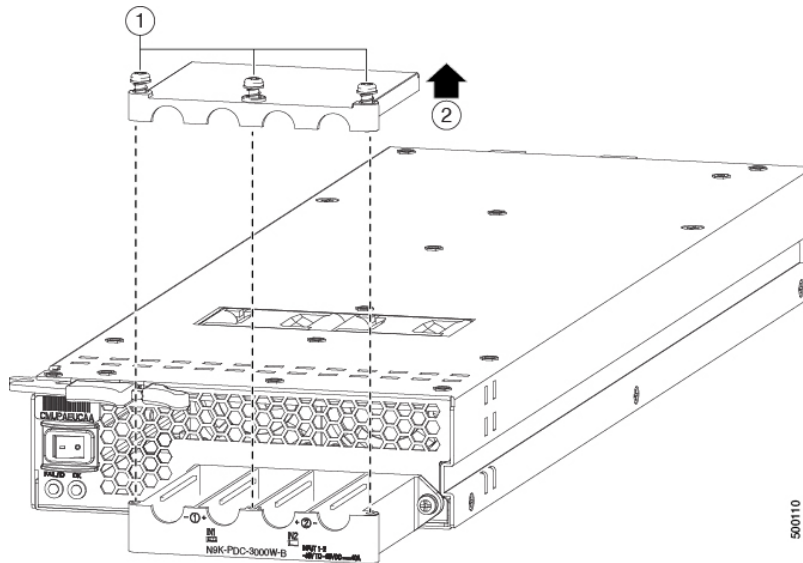

1	Remove 3 screws from the safety cover.	2	Remove the cover.
---	--	---	-------------------

2. Unscrew the two nuts holding each of the four cables to the terminal box, remove the cables, and replace the nuts on the two posts in each of the slots.
 3. Replace the safety cover on the terminal box and secure it in place with three screws.
- c) Remove the power supply from the chassis as follows:
1. Slide the middle of the ejector lever down to the end of the lever and rotate the lever away from the chassis. The power supply unlocks from the chassis and moves out slightly.
 2. Pull on the lever to move the power supply about 2 inches (5 cm) out of the slot.
 3. Place one hand on the front of the power supply and your other hand under the power supply to support its weight.
 4. Pull the module out of the slot and place it on an antistatic surface or inside an antistatic bag.

Step 4 To install the new power supply, follow these steps:

- a) If you are using a DC power source, ensure that the circuit is turned off at the circuit breaker.
- b) Hold the front of the power supply module with one hand and place your other hand under the module to support its weight.
- c) Slide the guide bracket into the track of the power supply slot. Slide the power supply into the slot until the front of the module stops about 0.25 inches (0.6 cm) in front of the module.

- d) Slide the handle on the middle of the power supply release lever towards the end of the module and rotate the lever away from the front of the power supply while pushing the power supply all the way into the chassis (see the following figure).

Figure 87: Install DC Power Supply

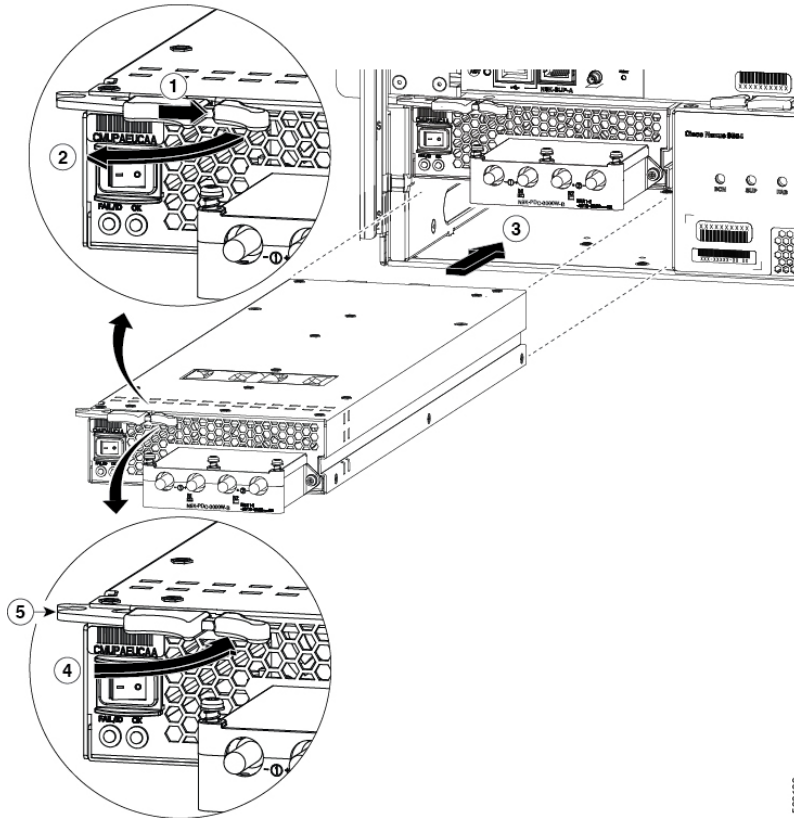

500109

1	Slide and hold the middle handle next to the outer handle.	4	Rotate the lever towards the front of the module.
2	Fully rotate the release lever away from the front of the module.	5	Make sure that the other end of the lever grabs the front of the chassis to push the module onto the connectors inside.
3	Slide the power supply into the open power supply slot in the chassis until it stops with the front of the module about 0.25 inches (0.6 cm) in front of the chassis.		

- e) Rotate the ejector lever toward the front of the power supply and be sure that the other end of the lever locks into the chassis.

The lever should click when you rotate it all the way to the front of the power supply. Be sure that the power supply is fully inserted into the slot (the front of the power supply should be even with the surface of the chassis) and securely in place.

Step 5 Connect the power cables to the power supply as follows:

- a) Verify that the circuit breakers for both input lines from the DC power source are turned off.
- b) Use a torque screwdriver to unscrew three screws on the cover for the terminal box that is located on the front of the power supply and lift off the cover as shown in the following figure.

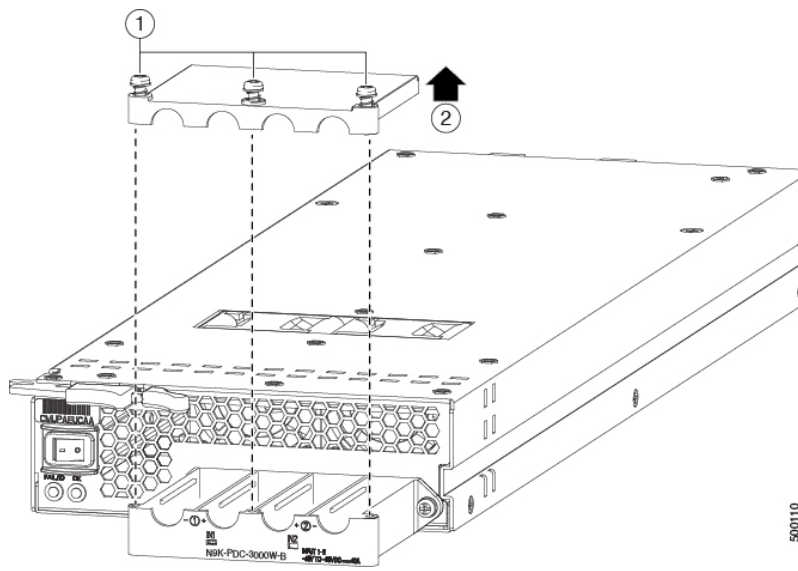

1	Remove 3 screws from the safety cover.	2	Remove the cover.
---	--	---	-------------------

- c) Remove the two nuts from each terminal post in each slot of the terminal box.
- d) Place each of the lugs for the two positive cables on the terminal posts for the positive slots (two middle slots) of the terminal box and fasten each lug using two nuts tightened to 40 in-lb (4.5 N·m) of torque.
- e) Place each of the lugs for the two negative cables on the terminal posts for the negative slots (two side slots) of the terminal box and fasten each lug using two nuts tightened to 40 in-lb (4.5 N·m) of torque.
- f) Replace the safety cover on the terminal box and fasten it in place using its three screws.

Step 6 Power up the power supply as follows:

- a) Turn on the power source circuit breaker for both input lines.
Verify that the Input 1 (IN1) and Input 2 (IN2) LEDs light up on the power supply.
- b) Turn the power switch on the power supply to ON (labeled 1 on the power supply).
The LEDs should flash and then the OK LED should turn on (green) in addition to the Input LEDs.

Replace HVAC/HCDC Power Supply

Before you begin

- The power source must be installed within reach of the power cables.
- The power source must meet the power specifications required by the switch.
- There are one or two power sources available. If using $n+n$ redundancy, there must be two power sources available. Otherwise, only one power source is required.

Step 1 Open the packaging for the new HVAC/HVDC power supply and inspect the module for damage.

If the module is damaged, contact the Technical Assistance Center (TAC).

Step 2 If you are installing the module in an empty slot, remove the blank filler plate that is already in that slot by unscrewing its captive screw and pulling it out of the slot.

Go to Step 4.

Step 3 If you are replacing a power supply that is currently in the chassis, remove the existing module from the chassis by following these steps:

Figure 88: Removing an HVAC/HVDC Power Supply

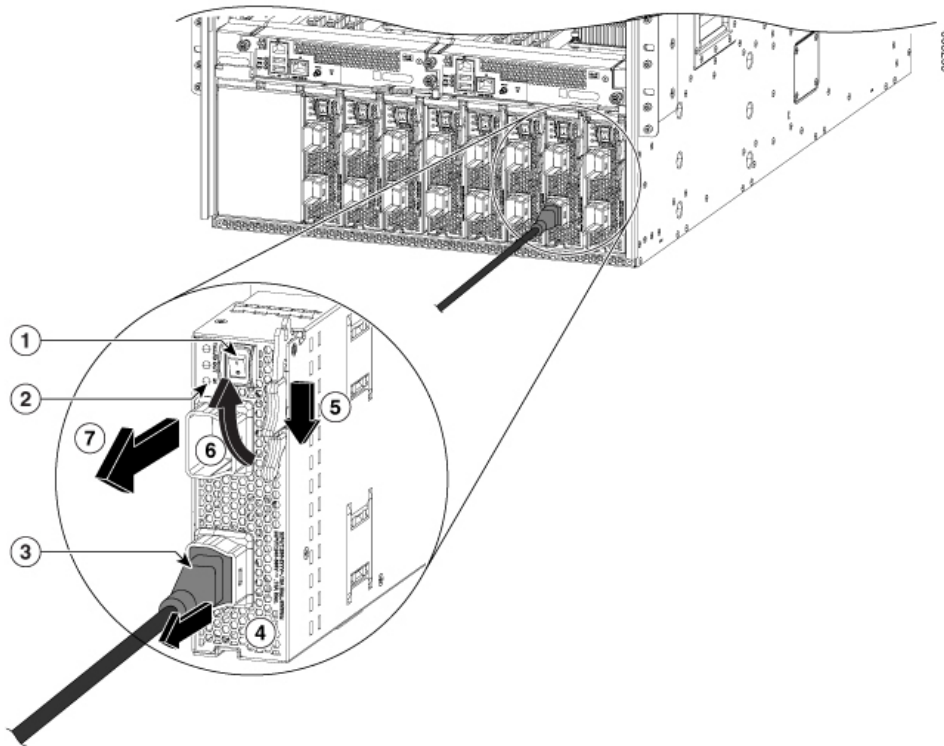

1	Turn off the power supply (and circuit breaker for a DC circuit)	5	Pull the middle lever handle toward the end of the lever.
2	Verify that the OK LED turns off. Note The FAULT LED might be on and amber colored to indicate that the power source connection has been broken.	6	Rotate the release lever away from the power supply.
3	Press and hold the release button on the plug.	7	Pull the module out of the slot and place it on an antistat surface or inside an antistatic bag.
4	Pull the power cable plug out of the power supply receptacle.		

Step 4 To install the new power supply, follow these steps:

Note If you are using a DC power source, ensure that the circuit is turned off at the circuit breaker.

Figure 89: Installing an HVAC/HVDC Power Supply

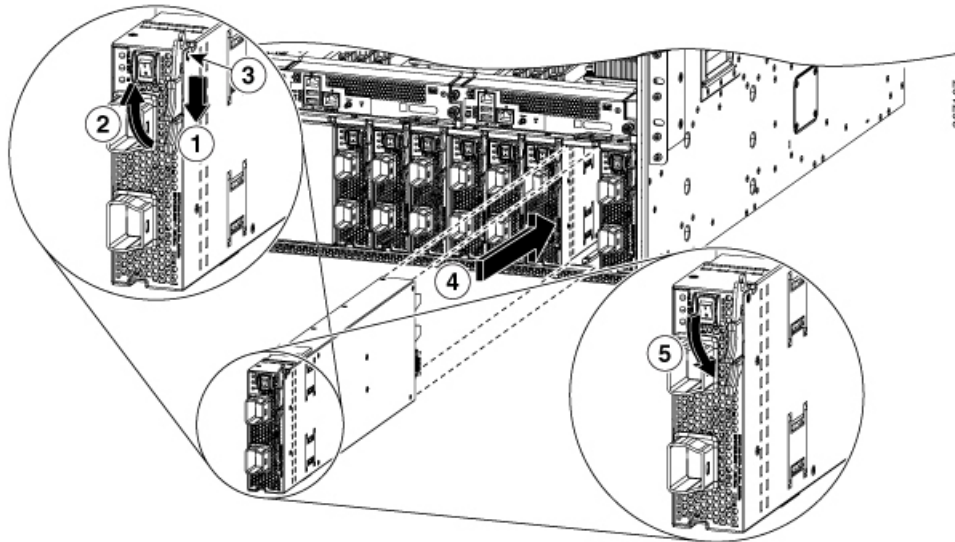

1	Slide and hold the middle handle on the ejector lever toward the end of the lever.	4	Slide the rear end of the power supply all the way into the slot and press the ejector lever toward the front of the power supply to lock it in the slot.
2	Rotate the ejector lever away from the module.	5	Rotate the lever to the front of the power supply and press the lever to lock the power supply into its slot by trying to pull it out.
3	Make sure that the locking knob has rotated into the power supply and cannot prevent the power supply from sliding all the way into the chassis slot.		

Step 5 Attach the power cable to the power receptacle on the power supply.

Note If you are using $n+n$ redundancy mode, you must connect one set of the power supply inputs to one power grid and the other set of the power supply inputs to another power grid (for example, connect grid A to the receptacles closest to the power switch on the power supplies, and connect grid B to the receptacles furthest from the power switch on the power supplies).

Step 6 Make sure that the other end of the power cable is attached to the power source.

Step 7 If you connected the power supply to a DC power source do the following, turn on the circuit breaker for the DC power source.

Step 8 Turn on the power supply by setting the power switch to on (1).

Step 9 Verify that the OK LED turns on and eventually becomes green.



APPENDIX A

LEDs

- [Chassis LEDs, on page 167](#)
- [System Controller LEDs, on page 168](#)
- [Route Processor Card LEDs, on page 170](#)
- [Fan Tray LEDs, on page 172](#)
- [Fabric Card LEDs, on page 173](#)
- [Line Card LEDs, on page 174](#)
- [MPA LEDs, on page 175](#)
- [Power Supply LEDs, on page 176](#)
- [Port Status LEDs, on page 178](#)

Chassis LEDs

NCS 5504: Chassis LEDs are located at the bottom of the front of the chassis.

NCS 5508 and NCS 5516: Chassis LEDs are located at the top of the front of the chassis.

The LEDs indicate whether each type of module (route processor, controllers, line cards, fabric cards, fan trays, and power supplies) are fully functional or have a fault condition.

Table 20: Modular Chassis LED Descriptions

LED	Color	Status
ATTN	Flashing blue	The operator has activated this LED to identify this chassis.
	Off	This chassis is not being identified.
RP	Green	Route processor cards are all operational.
	Amber	Check the Route Processor Card LEDs for more information.
FC	Green	Fabric cards are all operational.
	Amber	Check the FAB LED description in the Fabric Card LEDs for more information.
	Off	No fabric cards are present, or all present fabric cards are in the shutdown configuration state.

LED	Color	Status
LC	Green	Line cards are all operational.
	Amber	Check the Line Card LEDs for more information.
	Off	No line cards are present, or all present line cards are in the shutdown configuration state.
PM	Green	Power supplies are all operational.
	Amber	Check the Power Supply LEDs for more information.
FT	Green	Fan trays are all operational.
	Amber	Check the Fan Tray LEDs for more information.
PWR MGMT	Green	Sufficient power is available for all of the installed modules.
	Amber	Either of the following conditions: <ul style="list-style-type: none"> • Insufficient power for at least one of the installed modules. • The configured power redundancy mode differs from the operational power redundancy.

System Controller LEDs

The system controller module LEDs are located on the left side of the module.

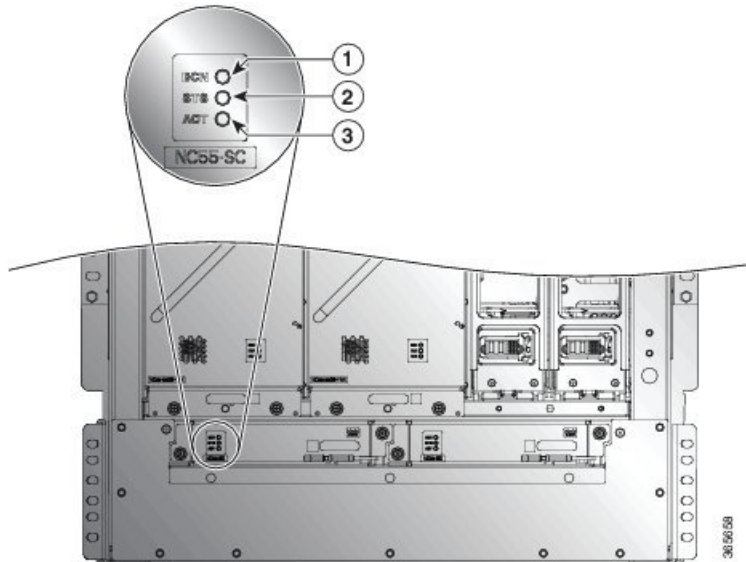
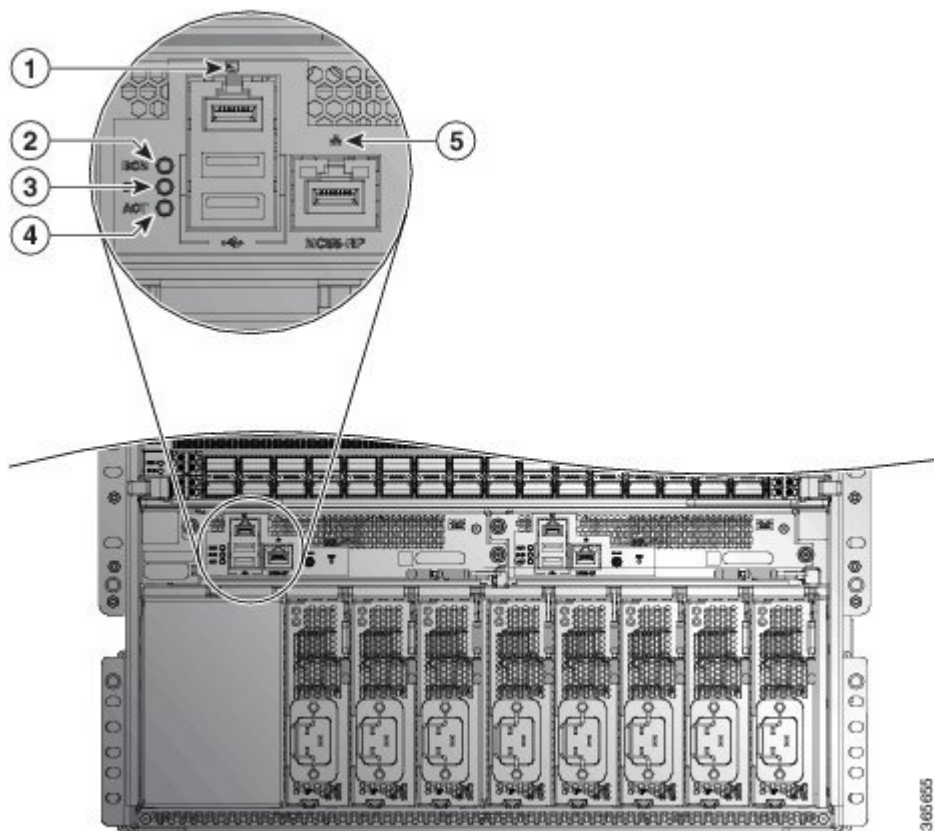

Table 21: System Controller LED Descriptions

LED	Color	Status
ATTN	Flashing blue	The operator has activated this LED to identify this module in the chassis.
	Off	This module is not being identified.
STS	Green	This module is operational.
	Amber	The host kernel has booted and is ready to start System Administrator VM.
	Red	Either of the following conditions: <ul style="list-style-type: none"> • The module has detected a slot ID parity error and will not power on or boot up. • The module is not fully inserted.
	Off	The module is not receiving power.
	Flashing Amber	The module is booting up or shutting down.
	Flashing Red	The module has active major or critical alarms.
ACT	Green	The controller module is operational and in active mode. This mode is established after the SysAdmin VM is booted up.
	Amber	The controller module is operational and in standby mode.
	Off	The hardware control is not established.

Route Processor Card LEDs



1	Attention (ATTN) LED	3	ACT (Active) LED
2	STS (Status) LED	4	Management port link and active LEDs

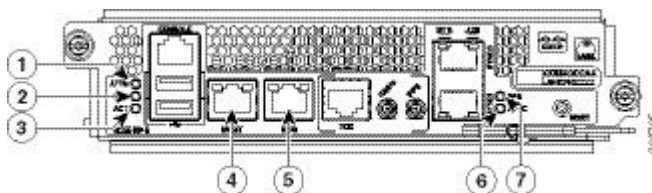

1	ATTN (Attention) LED	5	1588 port link and active LEDs
2	STS (Status) LED	6	SYNC LED
3	ACT (Active) LED	7	SYNC LED
4	Management port link and active LEDs		

Table 22: Route Processor Card LED Descriptions

LED	Color	Status
ATTN (Attention)	Flashing blue	The operator has activated this LED to identify this module in the chassis.
	Off	This module is not being identified.
STS (Status)	Green	This module is operational.
	Flashing amber	The module is booting up or shutting down.
	Flashing red	The module has active major or critical alarms.
	Amber	Host kernel booted and is ready to start System Administrator VM.
	Red	Either of the following conditions: <ul style="list-style-type: none"> • The module has detected a slot ID parity error and will not power on or boot up. • The module is not fully inserted.
	Off	The module is not receiving power.
ACT (Active)	Green	XR VM is operational and is in the active redundancy role on this module.
	Amber	XR VM is operational and is in the standby redundancy role on this module.
	Off	XR VM is not operational on this module.
Management port LINK	Green	The management port is linked up.
	Off	The management port is not linked up.
Management port ACT	Flashing green	The management port is transmitting or receiving.
	Off	The management port is not transmitting or receiving.
1588 port LINK (NC55-RP-E only)	Green	The 1588 port is linked up.
	Off	The 1588 port is not linked up.
1588 port ACT (NC55-RP-E only)	Flashing green	The 1588 port is transmitting or receiving.
	Off	The 1588 port is not transmitting or receiving.

LED	Color	Status
SYNC (NC55-RP-E only)	Green	The frequency, time, and phase are synchronized with an external interface (BITS, GPS, Recovered RX Clock).
	Amber	The time core is in free-run or holdover mode.
	Off	The time core clock synchronization is disabled. This is the default state after a reset.
GPS (NC55-RP-E only)	Green	The GPS interface is provisioned and ports are turned on. Time of day (ToD), 1 packet per second (1PPS), and 10MHz are all valid.
	Off	Either the interface is not provisioned or the ports are not turned on. ToD, 1PPS, and 10MHz are not valid.

Fan Tray LEDs

The fan tray LEDs are located on the lower right portion of the module.

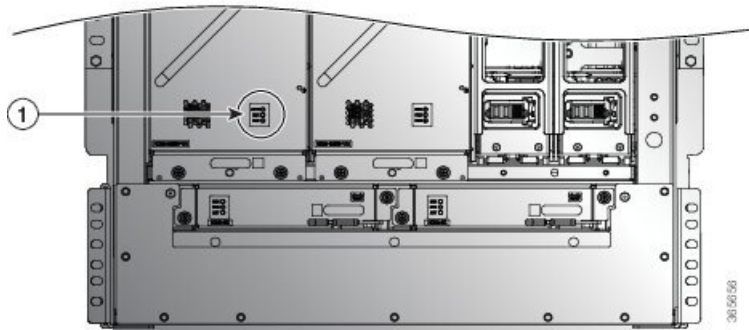

		LED	Color	Status
1	LED location	ATTN or BCN	Flashing Blue	The operator has activated this LED to identify this module in the chassis.
			Off	This module is not being identified.
		FAN	Green	The fan tray is operational.
			Flashing Red	One or more fans in this fan tray has failed.
			Off	No power is going to the fan tray.
		FAB	Green	Both fabric cards behind this fan tray are operational.
			Amber	At least one fabric card behind this fan tray is not operating.
			Off	No power is going to the fabric card behind this fan tray.

Fabric Card LEDs

The NCS 5504, NCS 5508 and NCS 5516 fabric cards are located behind the fan trays.

Table 23: Fabric Card LED Descriptions

LED	Color	Status
ATTN (top LED)	Flashing blue	The operator has activated this LED to identify this module in the chassis.
	Off	This module is not being identified.
STS (bottom LED)	Green	The fabric card is operational.
	Amber	Host kernel booted and is ready to start System Administrator VM.
	Red	Either of the following conditions: <ul style="list-style-type: none"> • The module has detected a slot ID parity error and will not power on or boot up. • The module is not fully inserted.
	Flashing red	The fabric card has major or critical alarms.
	Flashing amber (Slow)	The fabric card is booting up or shutting down.
	Flashing amber (Fast)	The module is booting up (set by U-Boot), shutting down, or the SysAdmin VM is being reloaded.
	Off	No power is going to the fabric card.

LED	Color	Status
Pushbutton (Graceful Shutdown)	Green	Software is ready to handle the graceful shutdown using the push button.
	Flashing yellow	Graceful shutdown in progress.
	Off	Graceful shutdown is complete; the module can be safely removed.

Line Card LEDs

The Attention (ATTN) and Status (STS) LEDs are located on the front left of the module, and the Link LED for each port is located between the two rows of ports (each of these LEDs is a triangle pointing to the port above or below the LED).

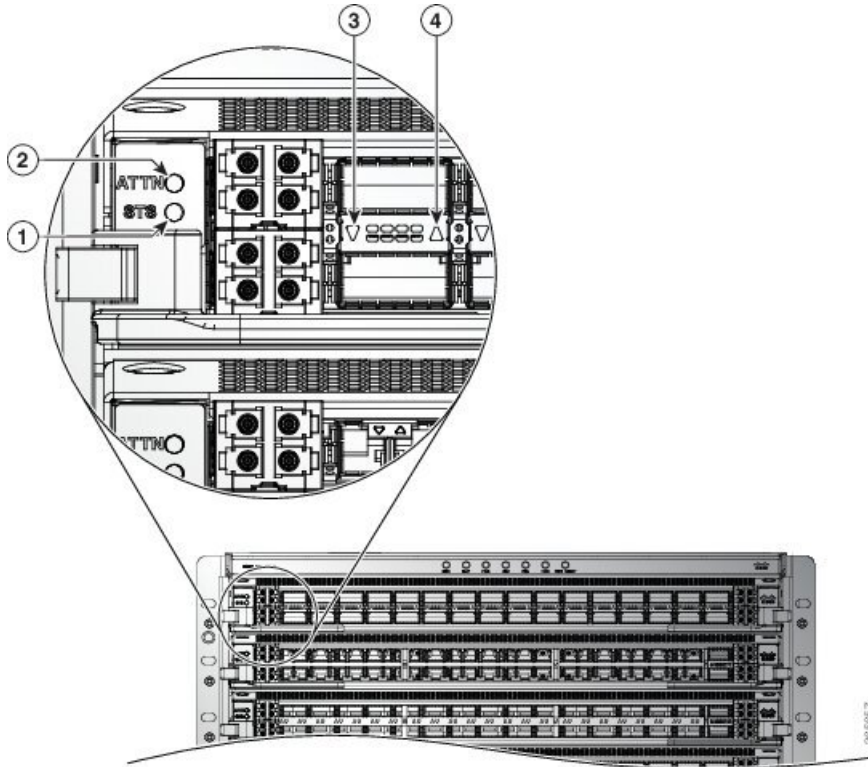

Table 24: Line Card LED Descriptions

LED	Color	Status
ATTN	Flashing blue	The operator has activated this LED to identify this module in the chassis.
	Off	This LED is not being used.

LED	Color	Status
STS	Green	This module is operational.
	Amber	Host kernel booted and is ready to start the system administrator VM.
	Red	Either of the following conditions: <ul style="list-style-type: none"> The card has detected a slot ID parity error and will not power on or boot up. The card is not fully inserted.
	Flashing red	The card has active major or critical alarms.
	Flashing amber	The card is booting up or shutting down.
	Off	The card is powered-off and can now be safely removed.
	Link (for each port)	Green
Orange		The port is disabled by the operator or is not initializing.
Flashing orange		The port is faulty and disabled.
Off		The port is not active or the link is not connected.

MPA LEDs

The STATUS LED is located on the front left of the MPA, the attention (ATTN) is located on the front right of the MPA, and the Link LED for each port is located between the two rows of ports (each of these LEDs is a triangle pointing to the port above or below the LED).

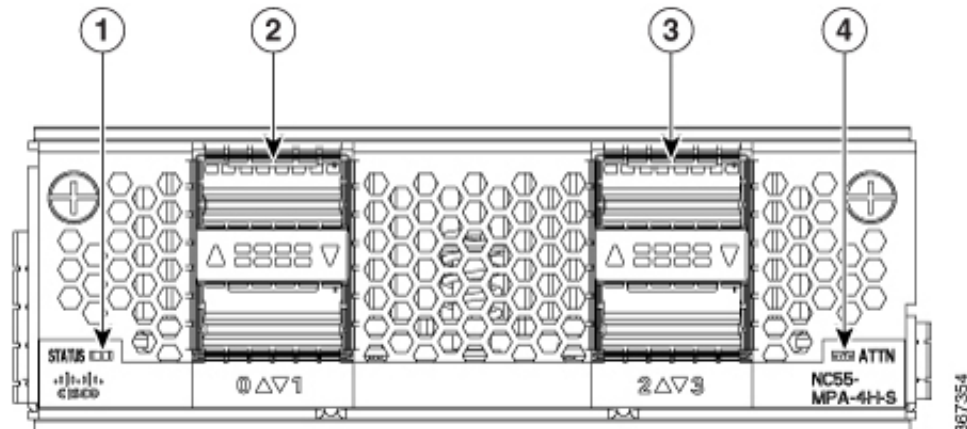

LED	Color	Status
ATTN	Flashing blue	The operator has activated this LED to identify this MPA in the chassis.
	Off	This LED is not being used.
STATUS	Green	This MPA is operational.
	Amber	Either of the following conditions: <ul style="list-style-type: none"> • The MPA has detected a slot ID parity error and will not power on or boot up. • The MPA is not fully inserted.
	Flashing amber	The MPA is booting up or shutting down.
	Off	The MPA is powered-off and can now be safely removed.
Link (for each port)	Green	The port is active.
	Orange	The port is disabled by the operator or is not initializing.
	Flashing orange	The port is faulty and disabled.
	Off	The port is not active or the link is not connected.

Power Supply LEDs

The power supply LEDs are located on the upper left front portion of the module.

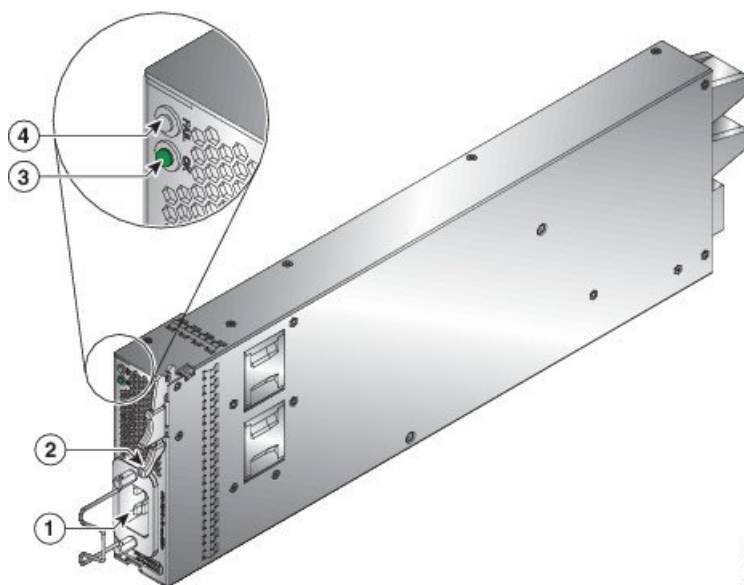

31687003

Table 25: Power Supply LED Descriptions

OK LED	FAIL or FAIL/ID LED	Status
Green	Off	Power supply is on and outputting power to the router.
Flashing green	Off	Power supply is connected to input power source but not outputting power to the router. The power supply might not be properly installed in the chassis.
Off	Off	Either all of the installed power supplies are not receiving power or an uninstalled power supply is not receiving power.
Off	Flashing amber - The amber LED blinks continuously at 1 second intervals.	Power supply is operating but a warning condition has occurred—possibly one of the following conditions: <ul style="list-style-type: none"> • High temperature • High power • Slow power supply fan • Low voltage • Power supply is installed without a connection to a power source.
Off	Amber	Power supply failure—possibly one of the following conditions: <ul style="list-style-type: none"> • Over voltage • Over current • Over temperature • Power supply fan failure

Table 26: HVAC/HVDC Power Supply LED Descriptions

IN LED	OUT LED	FAIL/ID LED	Status
Green	Green	Off	Both inputs are connected to power source. Power supply is on and outputting power to the router.
Flashing green	Green	Off	Power supply is connected to input power source but not outputting power to the router. The power supply might not be properly installed in the chassis.

IN LED	OUT LED	FAIL/ID LED	Status
Off	Off	Flashing amber - The amber LED blinks continuously at 1 second intervals.	Power supply is operating but a warning condition has occurred—possibly one of the following conditions: <ul style="list-style-type: none"> • High temperature • High power • Slow power supply fan • Low voltage • Power supply is installed without a connection to a power source.
Off	Off	Amber	Power supply failure—possibly one of the following conditions: <ul style="list-style-type: none"> • Over voltage • Over current • Over temperature • Power supply fan failure
-	-	Flashing blue	Power supply ID is enabled.

Port Status LEDs

Each port has an LED. The following table describes port status LEDs.

Table 27: Port Status LEDs (one per port)

LED Color	Description
Off	Port is administratively shut down.
Green	Port is administratively enabled and the link is up.
Amber	Port is administratively enabled and the link is down.
Single Amber Flash	Card reload is occurring. The LED blinks off-amber-off.