



VB-STND-003
Motorized Trolley Cart
Quick Setup Guide
Guide rapide début
Guía de configuración rápida
Konfigurationskurzanleitung

This device complies with part 15 of FCC Rules. Operation is subject to the following two conditions:
 (1) This device may not cause harmful interference, and
 (2) This device must accept any interference received, including interference that may cause undesired operation.

Industry Canada Statement
 CAN ICES-3 (B)/NMB-3(B)

CE Conformity for European Countries

The device complies with the relevant section of the EMC Directive 2014/30/EU, Low Voltage Directive 2014/35/EC, Eco-Design Directive 2009/125/EC, RoHS Directive (RED) 2011/65/EU

Following information is only for EU-member states:

The mark shown to the right is in compliance with the Waste Electrical and Electronic Equipment Directive 2012/19/EU (WEEE). The mark indicates the requirement NOT to dispose the equipment as unsorted municipal waste, but use the return and collection system according to local law.



CAUTION

This Cart for use only with specific ViewSonic Commercial Touch Display.
 See apparatus instructions. Use with other models is capable of resulting in instability causing possible injury.

TIPPING HAZARD!
 DO NOT move Cart with Display in highest position. DO NOT push Cart from front or back of Lift. DO NOT move Cart over cords or uneven, dirty, soft or sloping surfaces. DO NOT move Cart by pushing on Display. Failure to comply with this caution may result in Cart instability leading to equipment damage or personal injury.

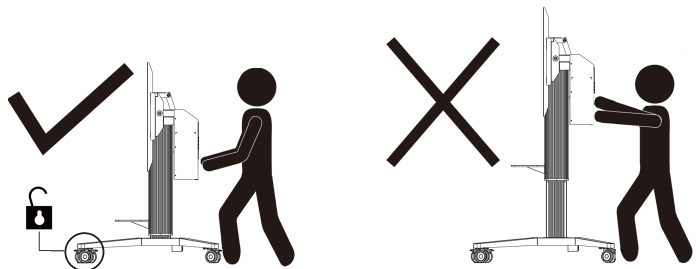

Physical Dimensions

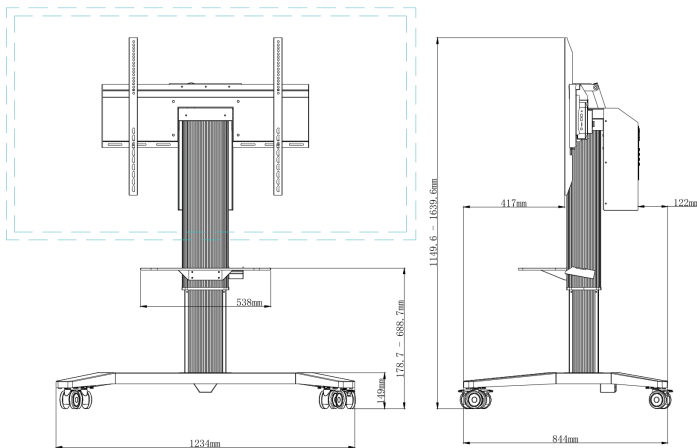

Enclosed Parts

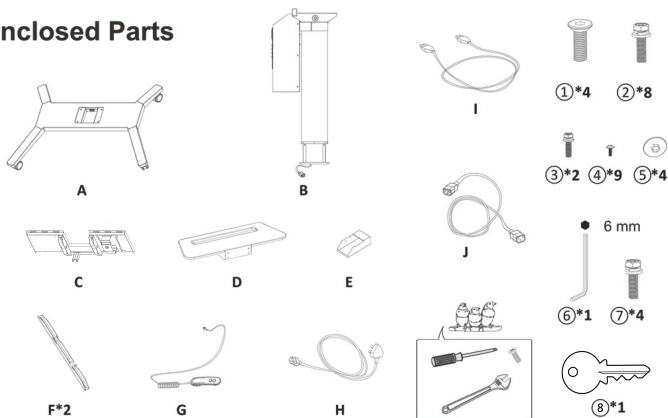

1

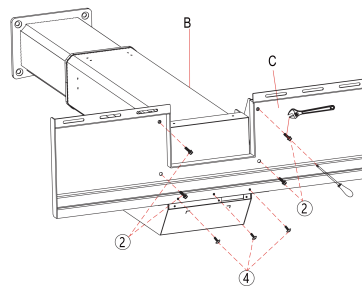

3

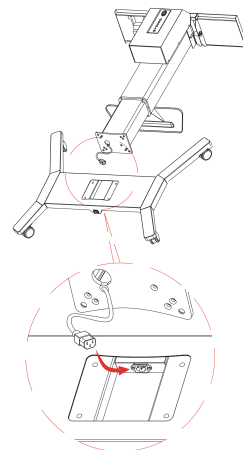

2

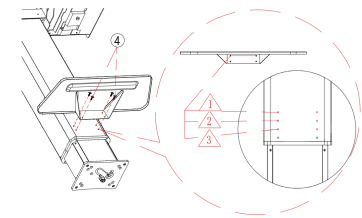

4

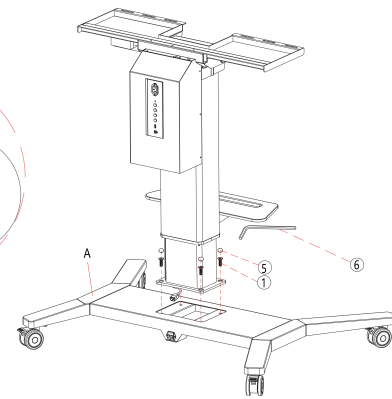

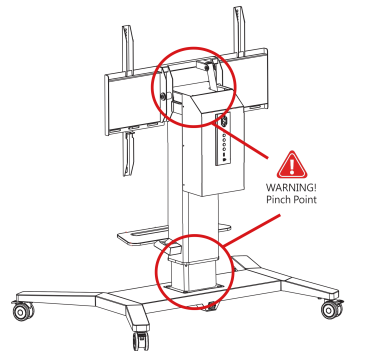
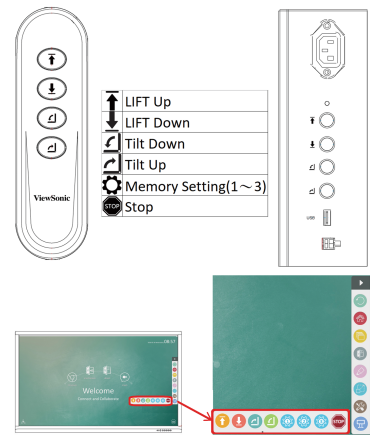
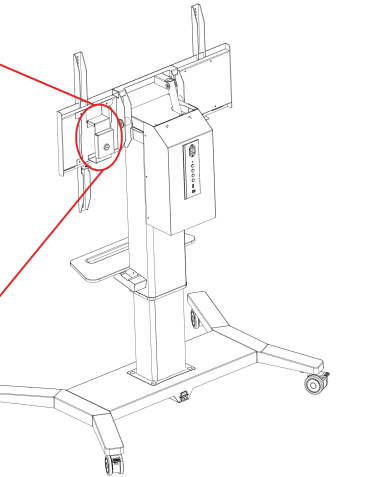
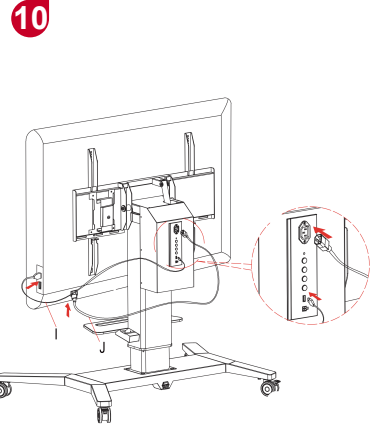
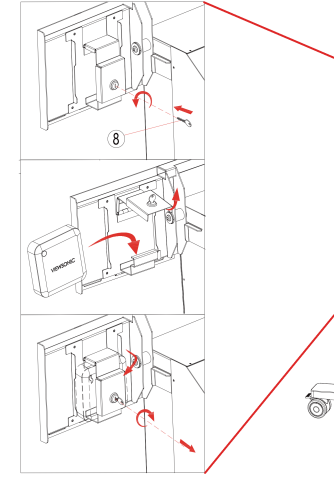
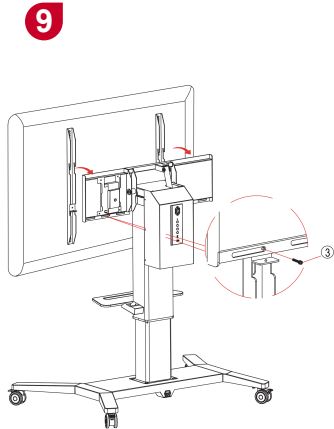
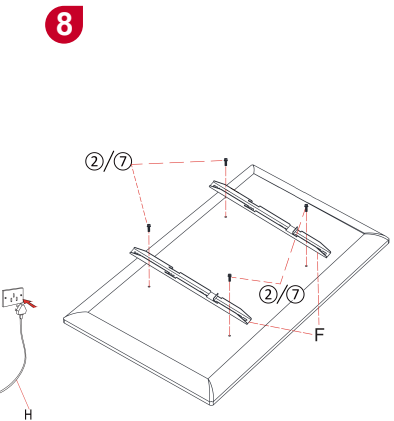
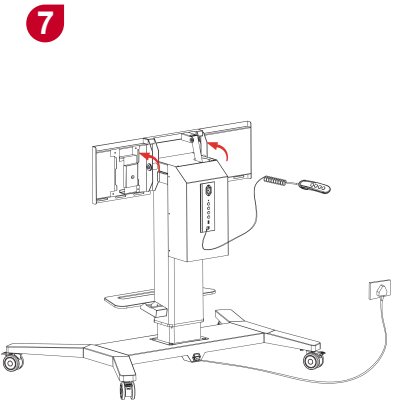
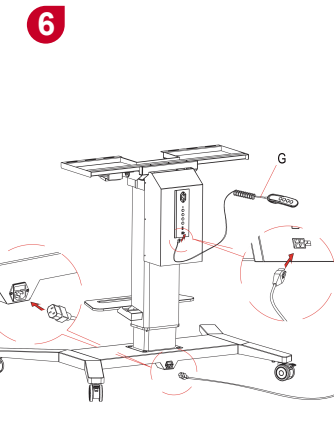
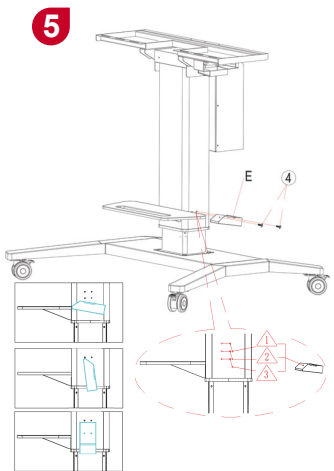

Specifications

Model	VB-STND-003
Model No.	VS17474
Tilt	0° ~ 90°
Swivel	360°
Height adjust range	490 mm 19.29 in
Wall mount pattern	800x600mm max.
Loading	75" max. 100 kg max. 220.46 lb max.
Input voltage	AC-in 100~240V 50/60Hz 1.0A
Control	Physical button control, control pad, software icon
Physical dimensions	1234 x 1149.6 x 844 mm 48.58 x 45.26 x 33.23 in
Net weight	54 kg 119.05 lb
Operation Conditions	Temperature: 32°F to 104°F (0°C to 40°C) Humidity: 20% ~ 80% non-condensing Altitude: ≤ 2000M
Storage Conditions	Temperature: -4°F to 140°F (-20°C to 60°C) Humidity: 10% ~ 90% non-condensing Altitude: ≤ 2000M

- 中国**
<http://www.viewsonic.com.cn>
电话: 4008 988 588
- 香港**
<http://www.hk.viewsonic.com>
电话: 852 3102 2900
- 澳门**
<http://www.hk.viewsonic.com>
电话: 853 2870 0303
- 台湾**
<http://www.viewsonic.com.tw>
电话: 0800 061 198
- 한국**
<http://ap.viewsonic.com/kr/>
Phone: 080 333 2131
- Europe**
<http://www.viewsoniceurope.com>
- Australia/New Zealand**
<http://www.viewsonic.com.au>
Phone: 1800 880 818 (AUS)
0800 008 822 (NZ)
- South Africa**
<http://ap.viewsonic.com/za/>
- Latin America**
Chile/Mexico/Peru/Argentina
<http://www.viewsonic.com/la/>
<http://www.viewsonic.com/la/sosporte/servicio-technico>
- Singapore/Malaysia/Thailand**
<http://www.viewsonic.com.sg>
Phone: 65 6461 6044
- India**
<http://www.in.viewsonic.com>
Phone: 1800 266 0101
- United States**
<http://www.viewsonic.com>
Phone: 1-800-688-6688
(Toll-Free)
1-424-233-2530 (Toll)
- Canada**
<http://www.viewsonic.com>
Phone: 1-866-463-4775
(Toll-Free)
1-424-233-2533 (Toll)
- Puerto Rico & Virgin Islands**
<http://www.viewsonic.com>
Phone: 1-800-688-6688
(English)
<http://www.viewsonic.com/la/sosporte/servicio-technico>
(Español)



<http://www.viewsonic.com/support/>