

# INSTALLATION INSTRUCTIONS:

1. Review the parts list and ensure you have all parts and tools required for assembly.
2. If converting another UT-2000 series product, first remove the existing side lugs and rear fences.
3. Loosely assemble the new kit to the base tray as shown in the exploded view.
4. Adjust and tighten the new kit according to the configuration instructions in the UT-2000 Series owner's manual or go to [www.havis.com](http://www.havis.com) for more information.

**NOTE: Retain all unused hardware for possible future re-use.**

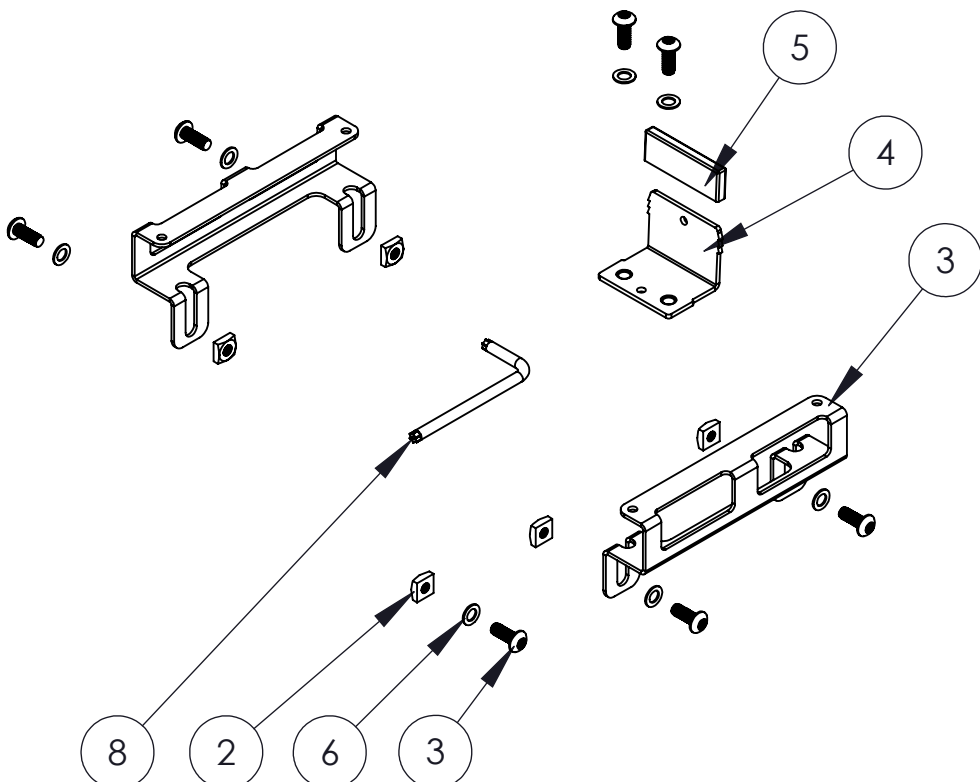
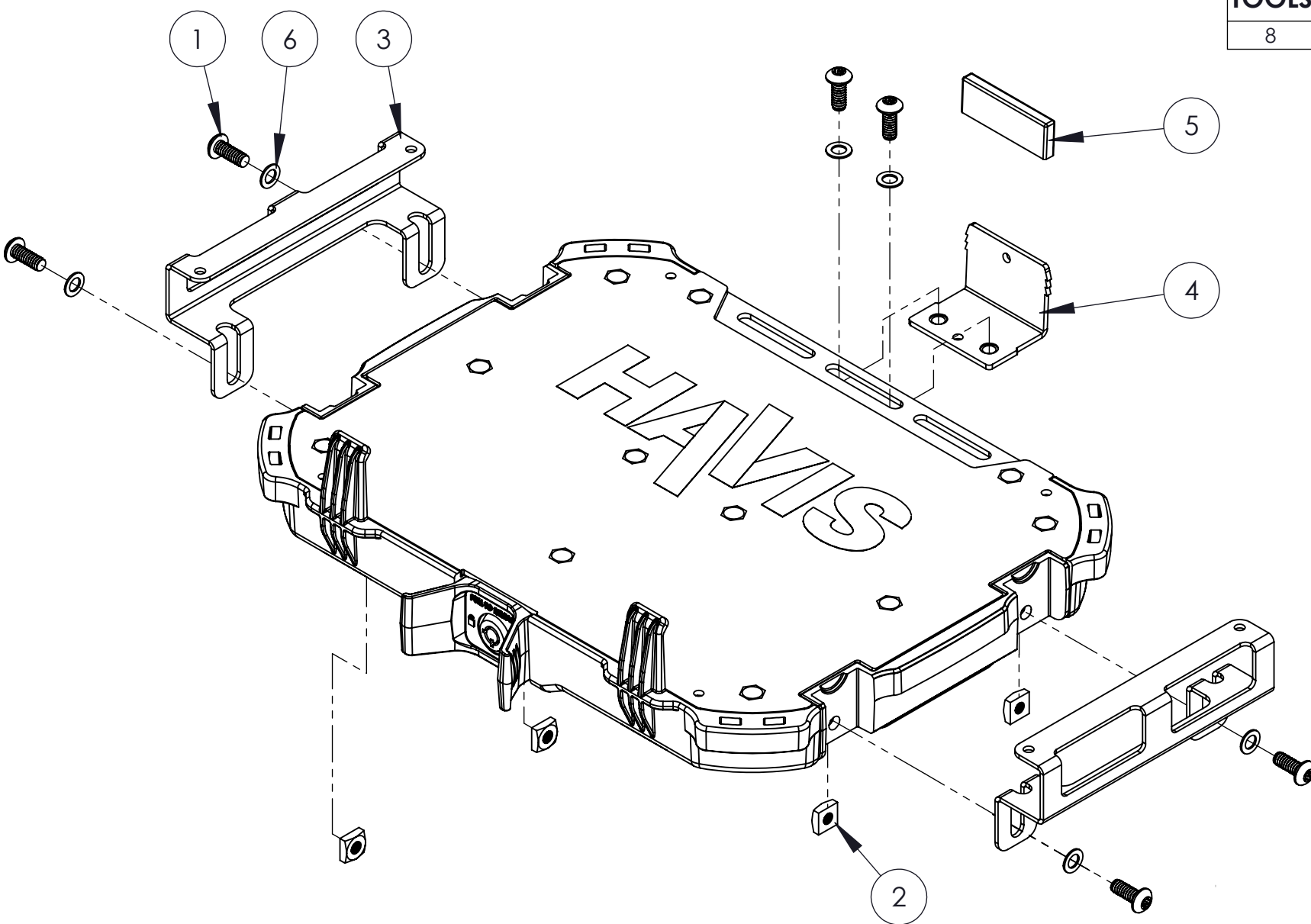

## UT-2010-KIT HARDWARE CONTENTS

### REPLACEMENT PARTS

ITEM NO.	DESCRIPTION	HAVIS PART NUMBER	QTY.
1	SCREW, BUTTON HEAD, PIN-IN-TORX, #10-32 X 0.5"	GSM33327	7
2	NUT, #10-32 X 0.375" SQUARE X 0.130"	HW-MN-0004/GSM30110	5
3	BRACKET, SIDE LUGS FOR UT-210 SERIES	UT-0178-SM	2
4	BRACKET, REAR FENCE	UT-0166-SM	1
5	CAP, RECTANGULAR 1.5" X 0.5" X 1/16"	HW-CA-0003/GSM41124	1
6	WASHER, BELLEVILLE, SERRATED, #10	HW-SW-1262/GSM31089	7
7	INSTALLATION INSTRUCTIONS, UT-2010-KIT	UT-2010-KIT_INST	1

### TOOLS

8	L-KEY TAMPER-RESISTANT, T25, 2-13/32" L	HW-AW-0006/GSM50261	1
---	---	---------------------	---

**DRAWING NUMBER:  
UT-2010-KIT\_INST\_6-19**

**WARNING: ALL HAVIS INC. PRODUCTS ARE DESIGNED WITH SAFETY OF USE AND INSTALLATION IN MIND. HOWEVER, IT IS THE SOLE RESPONSIBILITY OF THE OWNER/OPERATOR OF A VEHICLE USING HAVIS INC. MOUNTING AND DOCKING EQUIPMENT, TO INSURE THAT THE EQUIPMENT IS INSTALLED SO THAT IT WILL NOT INTERFERE WITH VEHICLE OPERATION, INTERFERE WITH SAFETY DEVICES, OBSTRUCT VIEW OF DRIVING CONDITIONS, OR IN ANY WAY DEGRADE OCCUPANT SAFETY. IMPROPER INSTALLATION CAN CAUSE SERIOUS INJURY IN THE EVENT OF AN ACCIDENT. INSTALLATION SHOULD ONLY BE PERFORMED BY QUALIFIED PROFESSIONALS. COMPUTERS AND MOTION DEVICES MUST BE MOVED TO AND STOWED/SECURED IN THEIR SAFE DRIVING POSITIONS BEFORE OPERATING VEHICLE.**

PRODUCT DESCRIPTION

**UNIVERSAL TRAY, UT-2000  
SERIES, DELL 5285& HP ELITE**

PRODUCT I.D. **UT-2010-KIT** DATE **06-07-19**

PRODUCT NAME **UT-2010 KIT**

**HAVIS**  
1-800-524-9900  
WWW.HAVIS.COM

WEIGHT: (LBS)  
REV. DATE **6-19**