

ASCEND ELECTRIC HEIGHT ADJUSTABLE TABLE / DESK

OPERATING INSTRUCTIONS

COMPONENTS:

30"x60" Table/Desk = ART3060 Top + AEB30 Base

24"x60" Table/Desk = ART2460 Top + AEB24 Base

24"x48" Table/Desk = ART2448 Top + AEB24 Base

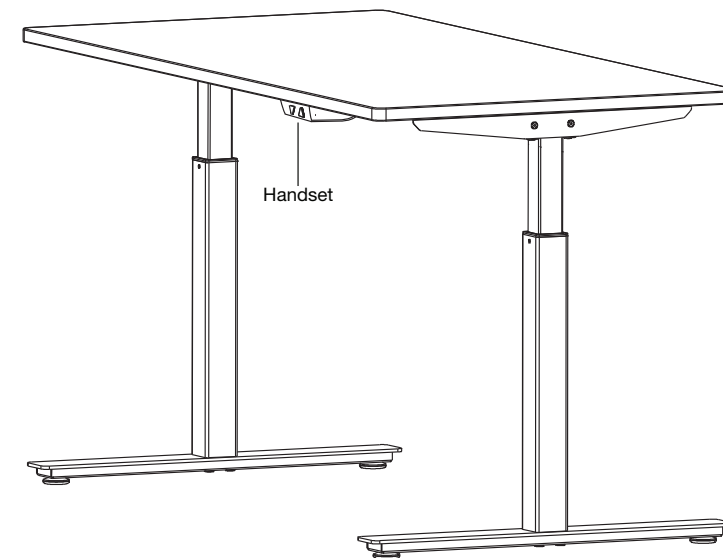

FEATURE

• ELECTRIC HEIGHT ADJUSTMENT

To raise top, press arrow (△) on handset and release when desired height is reached. To lower top, press arrow (▽) on handset and release when desired height is reached.

NOTE: Before use, be certain to reset handset as shown in Step 8.

WARNING

1. Use this product for its intended purpose.
2. Active weight capacity 250 lbs. When raising/lowering top, the maximum weight of Top plus all items resting on the Top must total 250 lbs. or less.
3. Stationary weight capacity 250 lbs. When top is in a resting position, the maximum weight of Top plus all items resting on the Top must total 250 lbs. or less.
4. Do not sit or stand on this product.
5. Do not use unless all fasteners are secured. At least every six months, check all connections to ensure they are tight.
6. Do not modify this product in any way.
7. If any parts are missing, broken, damaged or worn, stop use of the product until repairs are made using factory authorized parts.
8. Dispose of packing material properly.
9. Failure to follow these warnings could result in serious injury.

LIMITED WARRANTY

OSP Furniture is warranted from the original purchase date to the original purchaser for normal commercial usage - defined as a standard forty-hour work week - according to the below-listed schedule and limitations.

- Laminate Tops = 5 year warranty
- Electric Adjustable Height Base = 3 year warranty
- Warranted against failure due to materials and workmanship

Warranty Exclusions

This warranty will not cover labor, freight, or damage from misuse, abuse, negligence, alteration, assembly, installation, attachments, accident, vandalism, acts of nature or any other event beyond our control. The warranty does not cover cosmetic damage that may result from normal use. Liability for incidental or consequential damage is excluded. The user assumes all risk of injury resulting from use of this product.





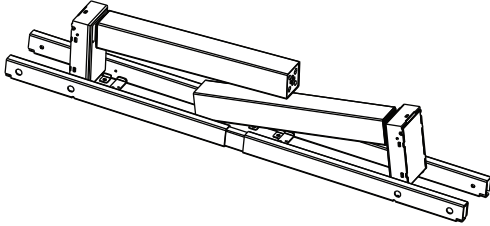
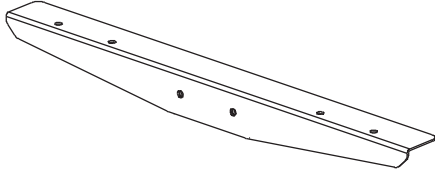
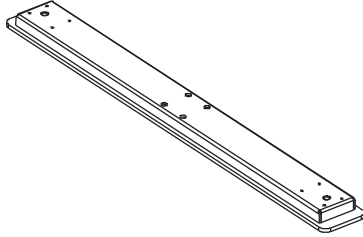
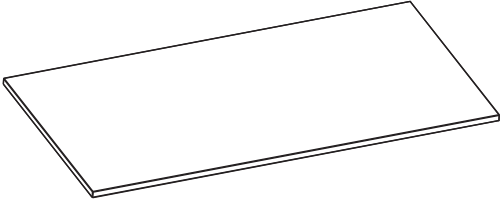
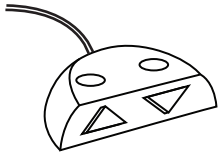

This warranty applies only to products purchased through authorized dealers and products sold within the United States of America and the Commonwealth of Canada. This warranty does not apply to products used for rental purposes. This warranty gives you specific legal rights, and you may also have other rights which vary from state to state.

ASCEND ELECTRIC HEIGHT ADJUSTABLE TABLE / DESK

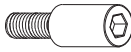
ASSEMBLY INSTRUCTIONS

Table Consists of:

A - Main Frame (1 pc)	B - Side Frame (2 pcs)
	
C - Feet (2 pcs)	D - Top (1 pc)
	
E - Handset (1 pc)	
	

No.	Drawing	Description	Qty.	No.	Drawing	Description	Qty.
F		Bolt	4 pcs	I		Bolt	8 pcs
G		Screw	2 pcs	J		Leveler	4 pcs
H		Screw	18 pcs	K		Threaded stud	4 pcs

ASCEND ELECTRIC HEIGHT ADJUSTABLE TABLE / DESK

ASSEMBLY INSTRUCTIONS

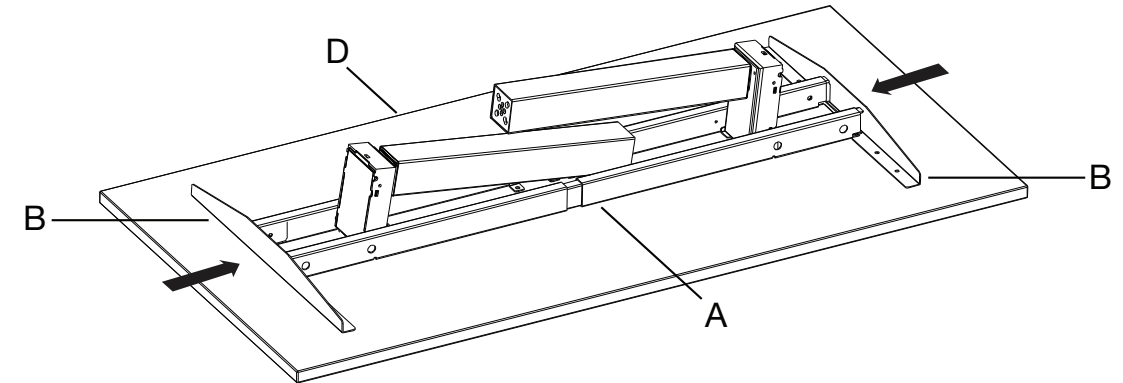

STEP 1: Place Main Frame (A) on Top (D). Slide Side Frames (B) onto Main Frame (A).

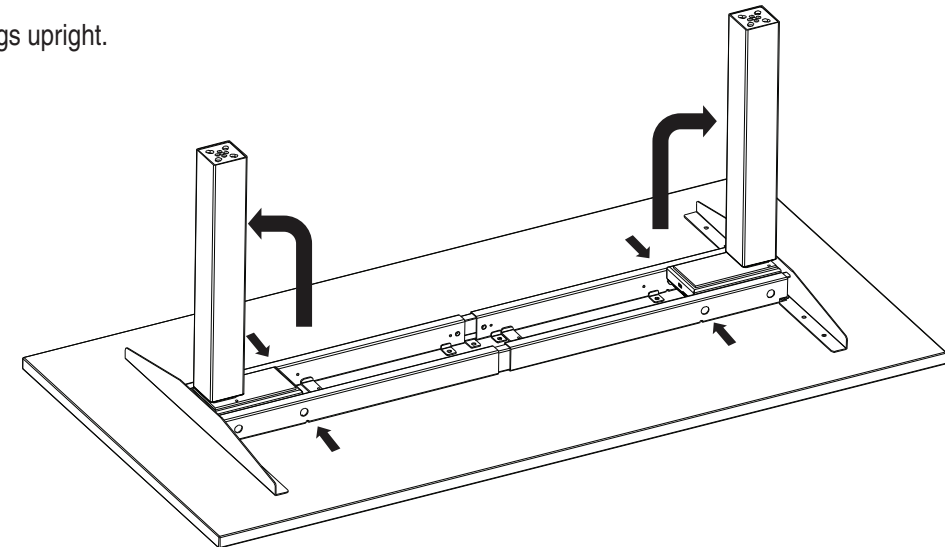

STEP 2: Rotate legs upright.

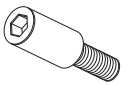

STEP 3: Secure legs into position using four Bolts (F).

Hardware	
	x4
Tool	
	5mm (not provided)

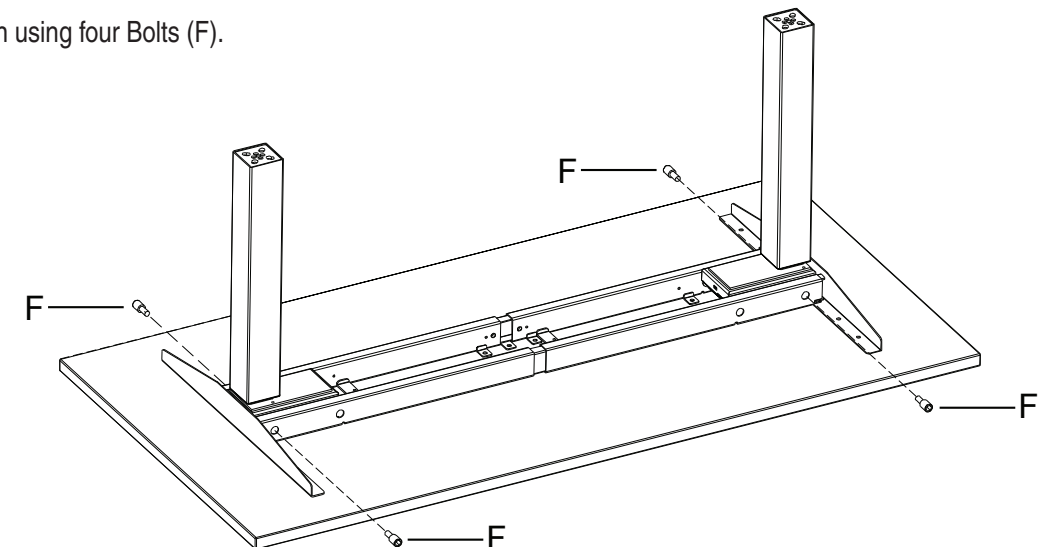

ASCEND ELECTRIC HEIGHT ADJUSTABLE TABLE / DESK

ASSEMBLY INSTRUCTIONS

STEP 4: Adjust width of Main Frame (A) to Top (D).

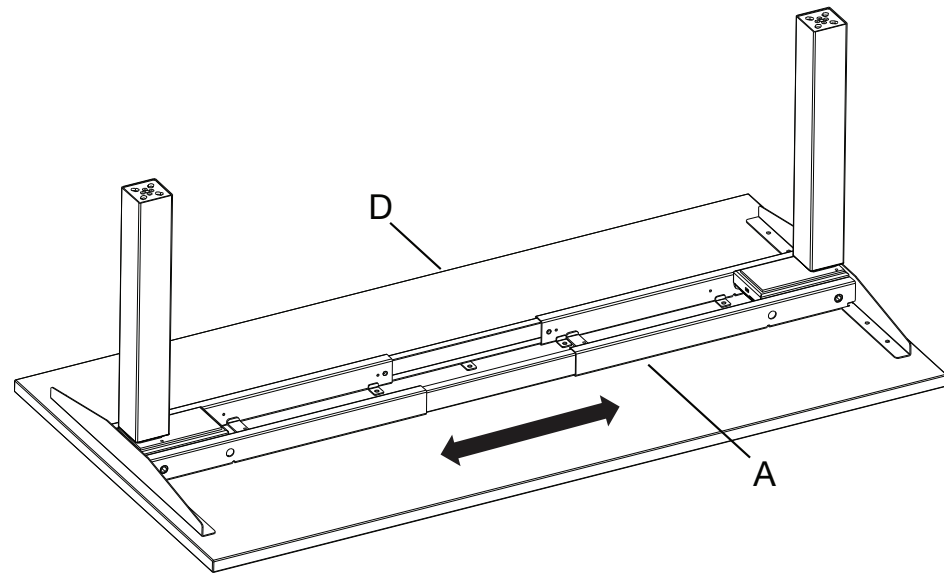

STEP 5: Secure Main Frame (A) to Top (D) using eighteen Screws (H). Attach Handset (E) to Top (D) using two Screws (G)

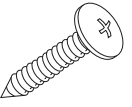
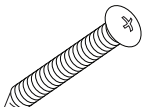
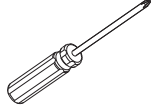

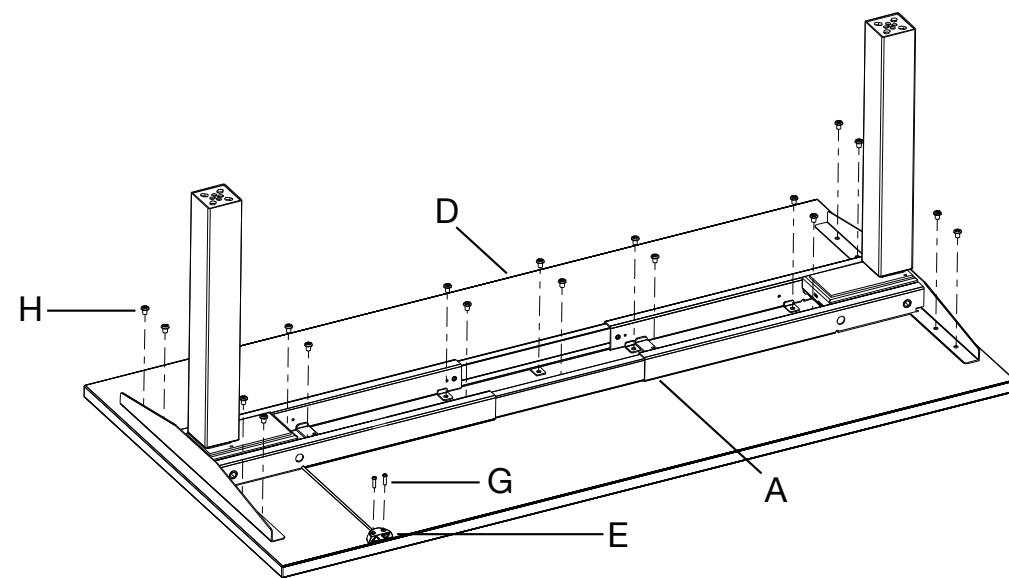
Hardware
 x18
 x2
Tool
 (not provided)



ASCEND ELECTRIC HEIGHT ADJUSTABLE TABLE / DESK



ASSEMBLY INSTRUCTIONS

STEP 6: Secure legs with pre-installed Threaded Studs (K).

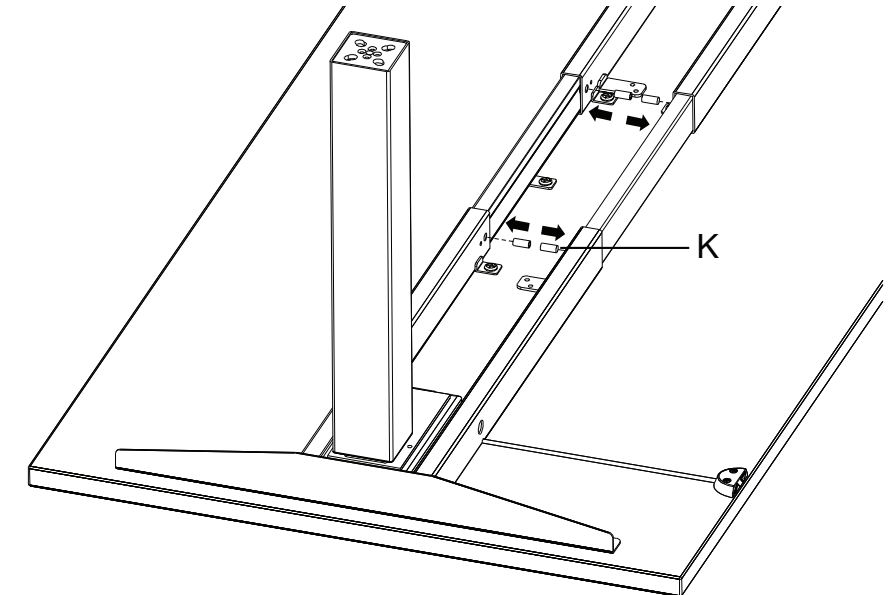
Hardware
 x4
Tool
 4mm (not provided)

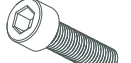

STEP 7: Secure Feet (C) to Main Frame (A) using four Bolts (I) for each foot. Install Levelers (J) to Feet (C).

Hardware
 x8
Tool
 5mm (not provided)

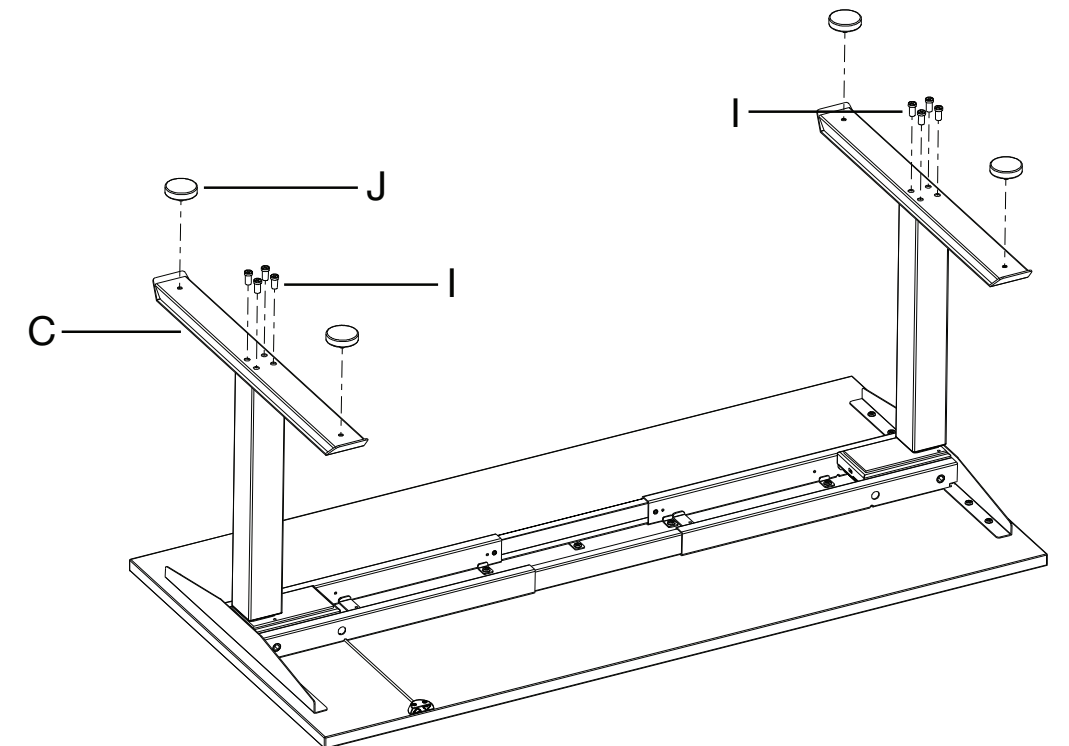

STEP 8:

BEFORE USE

- 1) Press and hold both buttons on Handset for 3 seconds.
- 2) Continue pressing the buttons until both columns are in the lowest position.
- 3) When reset is complete, the Handset will make a sound in which the buttons can then be released.
- 4) The system is now operational.