

iGENIX

UNDER COUNTER FRIDGE WITH CHILL BOX

Model Number: IG3920

INSTRUCTIONS FOR USE



**Thank you for purchasing this product.
Please read these instructions carefully before use**

**Trouble with your
refrigerator? ...**

**Try our troubleshooting
guide on page 9.**

**If that does not solve the
issue contact us ...**

IGENIX

Tel: 01473 271 272

Fax: 01473 270 733

Email: info@igenix.co.uk

Website: www.igenix.co.uk

Postal Address:

Customer Service Department
Pik-a-Pak Electrical Distributors
38 Bluestem Road,
Ransomes Europark,
Ipswich, IP3 9RR

When writing to or emailing us to report a fault please ensure you attach a copy of your proof of purchase. Please retain your original

SAFETY INSTRUCTIONS

Important: This appliance is not intended for use by persons including children with reduced physical, sensory or mental capabilities, or lack of experience and knowledge, unless they have been given supervision or instruction concerning use of the appliances by a person responsible for their safety.

- This product is intended to be used in a household and similar applications such as:
 - staff kitchen areas in shops, offices and other working environments;
 - farm houses and by clients in hotels, motels and other residential type environments;
 - bed and breakfast type environments;
 - catering and similar non retail applications.
- Do not use mechanical devices or other means to accelerate the defrosting process, other than those recommended by the manufacturer.
- Do not use electrical appliances inside the food storage compartments of the appliance, unless they are recommended by the manufacturer.
- Do not store explosive substances such as aerosol cans with a flammable propellant in this appliance.
- Ensure that the electricity supply in your home is rated at 220 - 240 volts before operating the appliance.
- Do not use the appliance if there is any damage to the power cord.
- Use of an extension cord is not recommended with this product.
- This product is for indoor use only.
- Keep packaging material out of the reach of children! It can become a choking or suffocation hazard.
- Always unplug the appliance before attempting to move it.
- Children should be supervised to ensure that they do not play with the appliance.
- Ensure that the refrigerant circuit is not damaged.
- The refrigerant of this product is R600a which is flammable. Ensure when moving the appliance or during installation that the cooling system does not get damaged.
- **DANGER: Risk of child entrapment**
 - Before you dispose of your old refrigerator or freezer, remove the doors and leave the shelves in place so that children cannot easily climb inside.
- When disposing of the appliance, remove the plug so the appliance is unusable.

IMPORTANT

Always allow 12 hours before turning on the refrigerator to allow the coolant gases time to settle after the refrigerator is in place.

Packaging

The cardboard packaging is recyclable and should be disposed of according to local regulations. Keep the packaging materials out of the reach of children. Before installation take care to remove all cardboard or other packaging, including material from the condenser tubes and any material surrounding the motor / compressor unit.

WARNING



The fridge is heavy and care is needed when unpacking and moving it. Get extra help and only hold the fridge by the casing – never hold by the door or the trim.

Check the Contents

Check the following contents are included with the product and inspect the casing for any damage. If necessary contact your retailer from where you purchased the product.

1 x full-width glass shelves
1 x half-width shelf over the Salad Crisper

1 x Plastic Salad Crisper

CE CE Marking certifies that this appliance conforms to the following EEC directives:
Low Voltage Equipment – 72/23/EEC & 93/68 EEC
Electromagnetic Compatibility 89/336/EEC, 92/31/EEC & 93/68/EEC

IG3920 - Under Counter Refrigerator at a Glance

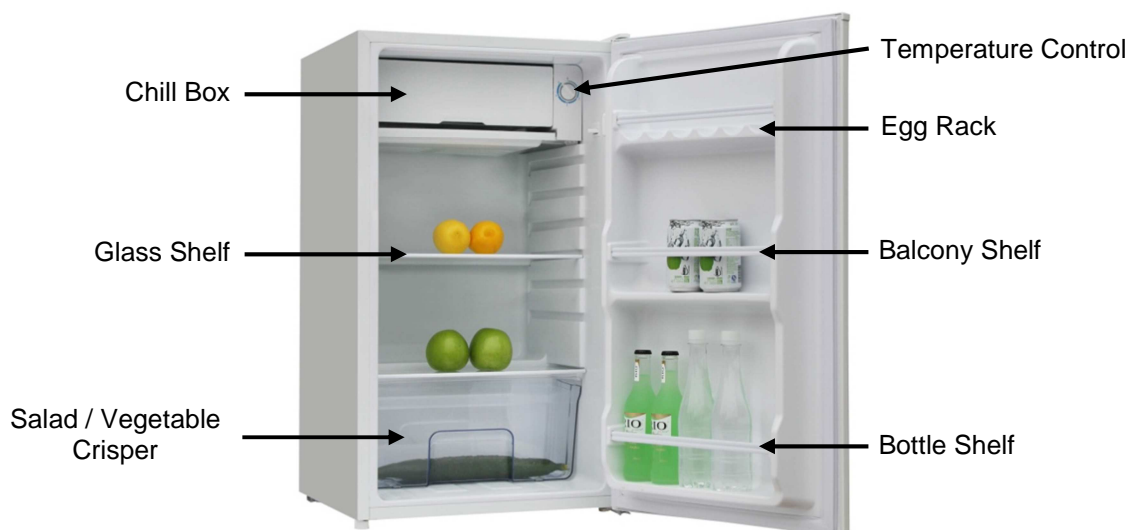

Installation

Location & Air Circulation

When selecting a position for your refrigerator, you should make sure the floor is flat and firm and the room is well ventilated with an average room temperature of between 18°C and 38°C.

Locate your fridge away from sources of heat e.g. cookers, radiators, direct sunlight as extreme temperatures will effect how efficiently your fridge works.

If you are placing your refrigerator in an out-building such as a garage or annex, ensure that the refrigerator is placed above the damp course. Failure to do this will result in condensation forming on the refrigerator cabinet and could cause the refrigerator to rust and fail.

Never place the refrigerator in a wall recess or fitted cabinets or furniture as this will not allow adequate ventilation and cause a potential fire hazard. Allow 10mm of space at the sides of the refrigerator and 20-30mm above the refrigerator. Never push the fridge back against the wall, leave at least a 10mm gap.

Providing you follow the recommended ventilation requirements you will:

- Increase the life of the fridge.
- Minimise the risk of condensation on the outside of the fridge.
- Minimise the running costs.
- Minimise operating noises caused by vibration.

Levelling

Once the refrigerator is positioned in its final location, it can be leveled using the adjustable feet at the front of the refrigerator until they are firmly placed on the floor. Correctly leveling the refrigerator will stop any rocking or vibration and keep the door aligned which helps the fridge run reliably and efficiently.

Door Fitting

The refrigerator door can be fitted to open to either the left or the right depending on its location. The appliance must be tilted and supported in order to carry this out. It is therefore advisable to get some help during this procedure. Take care when fitting and tightening screws.

To change the direction, please follow these instructions.

- Turn off the power.
- Remove the top hinge cover (1).
- Unscrew the upper hinge screw (2).
- Remove the upper hinge (3)
- Remove the door leg (4 & 7) and unscrew the screws.
- Remove the lower hinge (5)
- Change the position of the lower hinge (5) to the opposite side of the appliance.
- Locate and support the door onto the lower hinge (5) and replace the screws (6) and adjustable foot (4 & 7).
- Align the door and replace the upper hinge (3) and replace the screws (2).
- Fit the hinge cover (1).

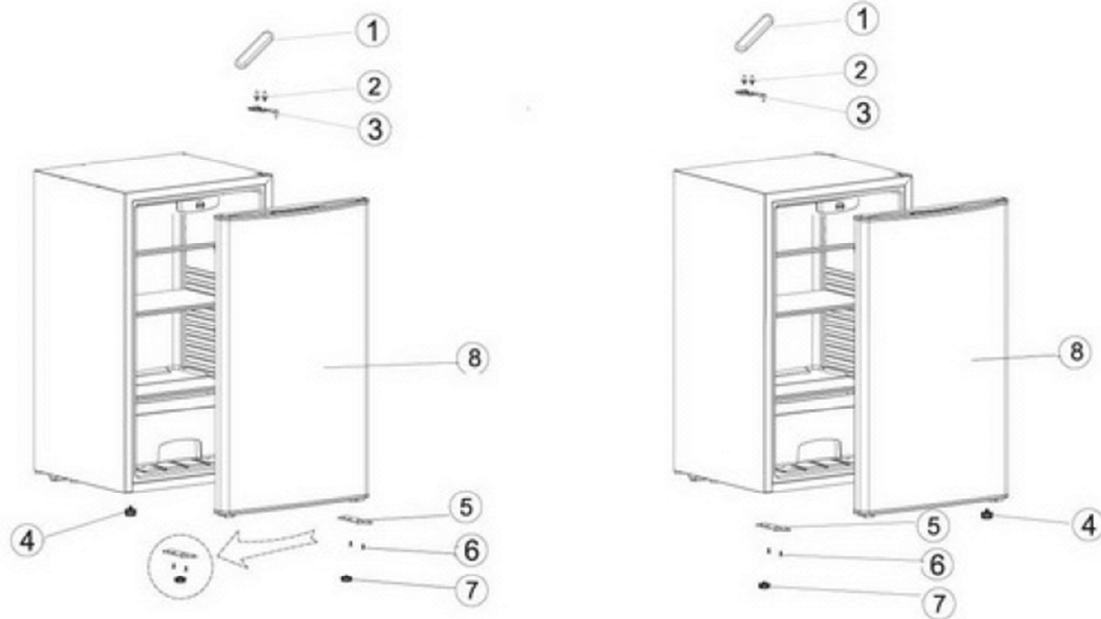

1. Upper Hinge Cover
2. Hinge Fixed Screws
3. Upper Hinge
4. Adjustable Foot

5. Down Door Hinge
6. Down Door Hinge Screws
7. Adjustable Foot
8. Door

Before using your Refrigerator

Before placing food in the refrigerator, it needs to be cleaned by wiping the interior using warm water and a soft cloth. Wipe the refrigerator completely dry before replacing any shelves or salad drawers.

Check that your power outlet is compatible with the plug supplied with the refrigerator.

IMPORTANT: Always allow at least 12 hours before turning on the refrigerator to allow the coolant fluid time to settle after the refrigerator is in place. Failure to do this may result in damage to the appliance and such damage is not covered by the guarantee.

Before placing any food in the refrigerator it is recommended to leave it 24 hours. This allows you to ensure the refrigerator is working correctly and gives enough time to allow the temperature in the refrigerator to drop to the correct level.

Using your Refrigerator

- Before turning on the refrigerator, make sure that the temperature control which is located inside the refrigerator is set between 3 and 4. This is the correct setting to use in a room with an average ambient temperature.
- Wait 24 hours before placing food in the refrigerator to allow the temperature to fall to the correct level.

Adjusting the Temperature

The ideal internal temperature of your refrigerator should be between $\pm 0^{\circ}\text{C}$ to $+5^{\circ}\text{C}$. This is controlled by the temperature control located on the internal right hand side of the refrigerator. There are 6 settings on the temperature control, with position 5 being the coldest setting, position 1 being the warmest setting and position 0 being the off position.

The temperature control should be set between 3 and 4 initially and adjusted to achieve the correct setting for your environment. Avoid setting the thermostat too high, as this may reduce the temperature to a point where some food begins to freeze. If this happens turn down the thermostat slightly.

The temperature in the fridge compartment can be monitored by using a Fridge Freezer Thermometer. Do not use a Mercury filled thermometer, as a breakage would cause a health hazard.

Your fridge must NOT be placed in a room where the temperature goes below 18°C or above 38°C for prolonged periods, as the internal fridge temperature will not be maintained.

Using your Fridge Efficiently

- Take note of foods best before / use by instructions and follow the maximum storage guidelines on the packaging.
- Keep foods covered to help retain moisture and to help prevent odour / flavour transference. Plastic bags, aluminium foil, plastic food wrap and containers with lids are ideal.
- Avoid opening the door for long periods or unnecessarily.
- Allow hot or warm food to cool down in covered containers before placing in the fridge. Hot food will raise the temperature in the fridge and cause the compressor to work more.

Storing Food in Your Fridge

- Pack and store cooked and fresh food separately.
- Wrap raw or defrosting meats and poultry in polythene or foil and ensure they are stored below any cooked meats to avoid contamination from any juices that may drip.
- Empty left over tinned food into plastic containers. Do not store food in tins in the fridge.
- Position food in the fridge to allow cold air to circulate freely, making sure that nothing touches the back wall of the fridge.

Defrosting

After a period of time, frost will build up in the ice box. Regular defrosting will therefore be necessary to maintain the efficiency of the refrigerator. Defrosting should be carried out if the frost build up begins to interfere with the food storage. The best time to defrost your freezer is when the amount stored in the freezer is low, for example before you go shopping. To defrost the ice box follow the steps below:

1. Take out the frozen food, turn the refrigerator off at the mains supply and leave the door open. Ideally the frozen food should be put into another freezer or refrigerator. To speed up the defrosting process, bowls of hot water can be placed inside the refrigerator to raise the temperature.
2. Remove the ice with an ice scraper. Do not use pointed or sharp edged objects such as knives, forks or screw drivers to remove the ice.
3. When all traces of ice have been removed and defrosting is completed, clean away any water and wipe your refrigerator dry.
4. Clean your refrigerator as described below, plug in and switch the refrigerator back on. Allow enough time for the temperature to fall to the correct level before putting the food back in to the refrigerator.

Cleaning and Maintenance

Switch off the electrical supply and remove the plug from the socket before cleaning.

Interior

1. Remove all food from the fridge and cover to help keep it cool.
2. Remove all shelves and the salad bin from the fridge and wash in warm soapy water with a soft cloth and dry thoroughly. Never put wet shelves or the salad bin into the fridge.
3. Wipe the interior of the fridge with a damp clean cloth. For extra cleaning use a solution of one teaspoon of bicarbonate of soda to one pint of water.
4. Dry the interior thoroughly with a clean cloth and replace the shelves.
5. Plug in and switch back on and allow the temperature in the fridge to drop to the correct temperature.
6. Replace the food in the fridge.

Exterior

Use a clean, damp soft cloth to wipe the exterior surface of the fridge and dry thoroughly.

 **WARNING:** Do not use abrasive powder, household cleaner, bleach or wax polish to clean the fridge as these can leave a smell in the fridge and can damage the exterior.

Use a vacuum cleaner to remove dust from underneath the fridge and from around the compressor situated at the back of the fridge. Use caution not to damage the coolant system.

Door Seal

Use a clean, damp soft cloth to wipe the door seal and in between the creases of it. Take care not to damage the seal and do not use sharp objects to clean it. Ensure that the seal is dried thoroughly before using the fridge. Do not use detergent on the seal as it will cause damage to it.

Going Away

If you are going away and do not want to leave the fridge left on, switch off at the socket and pull the plug from the mains. Remove any food and follow the cleaning instructions in the “Cleaning and Maintenance” section.

Note: Leave the door ajar as this will prevent odours accumulating in fridge and will allow the fridge to dry completely.

Operating Sounds of a Fridge

If you have not owned a refrigerator before, you may notice that it makes some rather unusual noises. Most of these are perfectly normal, but you should be aware of them!

The compressor makes a buzzing or humming sound when it is running. This can be louder when the fridge is first switched on but should become quieter in a few months.

Gases flowing through the cooling system can cause a gurgling, bubbling or whooshing sound. These noises are normal and have become more pronounced since the introduction of CFC free gases.

Expansion and contraction of parts inside the fridge can produce a cracking noise as they rapidly change temperature.

Product Specification

Model	IG3920
Climate Class	ST
Electric Protection Type	I
Total Net Capacity (Litres)	90
Voltage (V)	220 – 240
Frequency (Hz)	50
Current (A)	0.7
Noise (dB)	≤ 39
Energy Consumption (kWh / 24h)	0.3
Refrigerant	R600a / 21g
Gross Weight (Kg)	23
Interior Temperature (°C)	0 - 10

Disclaimer

Updates to hardware components are made regularly. Therefore some of the instructions, specifications and pictures in this documentation may differ slightly from your particular situation. All items described in this guide are for illustration purposes only and may not apply to your particular situation. No legal right or entitlements may be obtained from the description made in this manual.

Disposal of Old Electrical Appliances



The European Directive 2002/96/EC on Waste Electrical and Electronic Equipment (WEEE), requires that old household electrical appliances must not be disposed of in normal unsorted municipal waste. Old appliances must be collected separately in order to optimise the recovery and recycling of the materials they contain and reduce the impact on human health and the environment. The crossed out “wheeled bin” symbol on the product reminds you of your obligation, that when you dispose of the appliance it must be separately collected. Consumers should contact their local authority or retailer for information concerning the correct disposal of their old appliance.

Troubleshooting

If you are having problems with your fridge, please use our troubleshooting guide below. If you are unable to resolve the issue using the guide please ring our Customer Service Department on 01473 271 272. Please have the model code, batch number and purchase information available.

Problem	Possible Cause	Solution
The fridge does not work.	<ol style="list-style-type: none"> 1. Not properly plugged into the mains wall socket. 2. No electricity in the mains wall socket. 3. The door is not closed properly. 	<ol style="list-style-type: none"> 1. Plug in firmly. 2. Check fuse or breaker. 3. Make sure the door is properly aligned and creates a seal around the door.
The fridge is making a lot of noise.	<ol style="list-style-type: none"> 1. The pipe work is touching the wall or skirting board. 2. The fridge has not been levelled properly. 	<ol style="list-style-type: none"> 1. Pull the refrigerator forward so it does not touch the wall or skirting board. 2. Adjust the feet at the front of the fridge, ensuring they are in firm contact with the floor.
The temperature in the fridge is too warm.	<ol style="list-style-type: none"> 1. The thermostat is set too high for your environment. 2. The fridge is too close to a heat source. 3. There is not enough ventilation around the fridge. 4. The door is not closed properly. 	<ol style="list-style-type: none"> 1. Turn the thermostat to a higher number. See Adjusting the Temperature on page 6. 2. Move the fridge away from the heat source and out of direct sunlight. 3. Ensure there is a minimum gap of 10mm at each side and 30mm above the fridge. 4. Ensure that the door is properly closed and the seal is not damaged.
The temperature in the fridge is too cold.	<ol style="list-style-type: none"> 1. The thermostat is set too low. 	<ol style="list-style-type: none"> 1. Turn the thermostat to a lower number. See Adjusting the Temperature on page 6.
There is water beneath the salad bin and on the floor.	<ol style="list-style-type: none"> 1. There is something touching the interior back wall of the fridge. 	<ol style="list-style-type: none"> 1. Ensure no foods are touching the interior back wall of the fridge.
Ice builds up rapidly inside the fridge.	<ol style="list-style-type: none"> 1. Door is not closed properly. 2. Food and liquids are not covered. 	<ol style="list-style-type: none"> 1. Check to see if anything is stopping the door from closing properly. 2. Ensure all food is covered to prevent a build up of moisture in the fridge.

Fuse and Mains Plug Replacement

This product is supplied with a moulded plug, which contains a 13A fuse. If you are simply replacing the fuse, you must use a 13A fuse which has been approved by ASTA to BS1362.

If the plug becomes damaged, a new plug must be fitted. Replace the original plug with a 13A (BS1363) plug and make sure that it is fitted with an ASTA approved 13A fuse.

Never use the moulded plug without the fuse cover fitted.

To replace the plug:

1. Cut off the existing fitted plug and dispose of it.
2. The wires in the mains lead supplied with this appliance are coloured in accordance with the following code:

GREEN/YELLOW = EARTH (E)
BLUE = NEUTRAL (N)
BROWN = LIVE (L)

This product **MUST** be earthed.

As the colours of the wires in the mains lead may not correspond with the colour markings identifying the terminals in your new plug, proceed as follows:

The wire which is coloured GREEN or YELLOW/GREEN must be connected to the terminal which is marked with the letter E or \equiv symbol or a coloured GREEN or YELLOW/GREEN.

The wire which is coloured BLUE must be connected to the terminal in the plug which is marked with the letter N or coloured BLACK or BLUE.

The wire which is coloured BROWN must be connected to the terminal which is marked with the letter L or coloured RED or BROWN.

Ensure that the connections are tight and that no loose strands are left out of the terminals.



IF IN DOUBT CONSULT A QUALIFIED ELECTRICIAN – DO NOT ATTEMPT TO CHANGE THE PLUG YOURSELF

If the mains lead becomes damaged consult a qualified electrician.

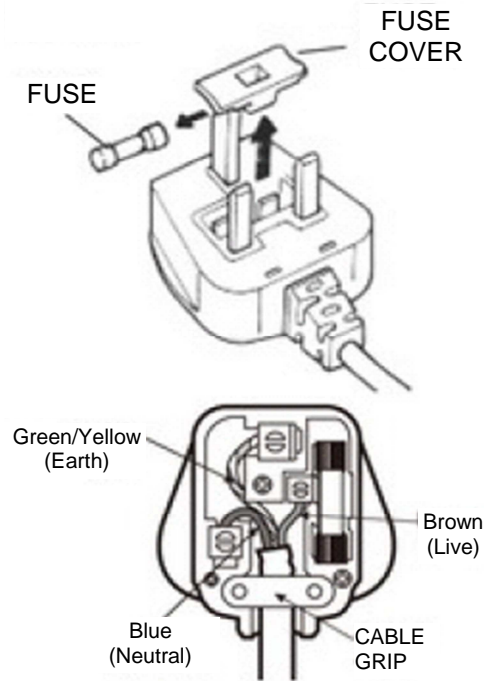

Guarantee Information

This product is guaranteed for a period of 12 months from the date of purchase against mechanical and electrical defects.

You can extend your warranty for a further 12 months by registering your product online. Visit www.igenix.co.uk to register your extended warranty. (Product must be registered within 30 days of purchase)

The warranty does not cover consumable parts that require replacement under normal use or accessories. This includes shelving, drawers and ice cube trays.

If your refrigerator becomes faulty within the guarantee period please contact our customer service department on 01473 271 272 or write to us at the address detailed on page 2.

Please quote the model number which begins **IG**, the 'Batch Number' beginning **'5'** and give details of the exact fault.

We will then decide whether to repair or replace the item.

You will be required to return a copy of your proof of purchase. **Please retain your original.**

If an item is replaced within the guarantee period, the guarantee for the replacement item will be calculated from the purchase date of the original.

Before calling the Customer Service number please ensure you have checked the Troubleshooting guide on Page 9.

This product is for domestic household use only. To qualify for the guarantee the product must have been used according to the instructions in the User Manual. Any misuse of the product will result in the warranty being void.

The logo for igenix, featuring the word 'igenix' in a bold, lowercase, sans-serif font. The 'i' has a dot, and the 'x' has a distinctive shape with a horizontal bar.

Tel: 01473 271 272

Fax: 01473 270 733

Email: info@igenix.co.uk

Website: www.igenix.co.uk

Postal Address:

Customer Service Department
Pik-a-Pak Electrical Distributors
38 Bluestem Road,
Ransomes Europark,
Ipswich, IP3 9RR

*When writing or emailing us to report a fault please ensure you attach a copy of your proof of purchase.
Please retain your original*



View the range online at www.igenix.co.uk



Follow us on Twitter
@Igenix_Products

IGENIX

Tel: 01473 271 272

Email: info@igenix.co.uk

Fax: 01473 270 733

Website: www.igenix.co.uk

Postal Address:

Customer Service Department
Pik-a-Pak Electrical Distributors
38 Bluestem Road,
Ransomes Europark,
Ipswich, IP3 9RR

*When writing or emailing us to report a fault please ensure you attach a copy of your proof of purchase.
Please retain your original*