

InfraStruXure™ Cooling Distribution Unit

ACFD12-T
ACFD12-B



Technical Data

Contents

Overview1

Scalable Solution for Critical Environments2

Standard Features5

InfraStruXure Model6

Performance Specifications8

Dimensional Data10

Guide Specifications12

Guidelines for Installation16

SKU Selection:			
	ACFD12-T ACFD12-B		
AC	FD	12	Piping Arrangement
Cooling Solution Product Line	Cooling Distribution Product Family	# of circuits supported	T = Top B = Bottom

Overview

The scalable, cooling distribution unit offers efficient, effective, and economical fluid distribution for use with the InfraStruXure InRow RC.

Precision environmental requirements now reach far beyond the confines of the traditional data center or computer room to encompass a larger suite of applications referred to as technology rooms. Critical environment applications include:

- Computer rooms
- Telecommunication facilities
- Clean rooms
- Power Equipment
- Medical equipment rooms
- Archives
- LAN/WAN environments

A worldwide network of APC representatives is fully qualified to provide engineering, sales, installation, and service for our products.

APC warrants all parts for 12 months from shipment. Extended warranties are available.

Capacity

The InfraStruXure Cooling Distribution Unit or CDU is available for up to 12 InRow RC units.

Cooling Distribution

Cooling distribution systems are placed either inside or outside of the data center. Fluid is pumped into the CDU's main supply header from the chiller, distributed into individual supply lines, absorbs rejected heat from the air through the RC, and is routed back to the chiller through the CDU's return lines.

The InfraStruXure CDU is manually set to ensure that fluid flow is equal to all of the InRow RCs. Improper fluid flow could result in hot spots within the data center.

Configuration

- Chilled Water
- Glycol / Chilled Water

Compliance Approval

- UL Listed to UL 1995 and CSA C22.2 No. 236



Standard Components

- Manual Isolation and Balancing Valve
- Individually controlled supply and return lines
- Multiple Supply and Return Lines
- Main Supply and Return Headers
- Distribution Piping as Top or Bottom Configuration
- Flexible and Jointless Piping
- Pipe Couplings
- Pipe Insulation
- Pipe Clamp / Hanger
- Secure Lockable Panels
- Main Supply and Return (Field Configurable as Top or Bottom)
- Matching Brass and Dielectric Flanges for Chilled Water Connection

Scalable Solution for Critical Environments

Overhead Piping Design

Mitigating the risk of fluid leaks is critical to the smooth operation of a technology room. Data centers can be installed where raised floors are not available. This hard floor environment requires that the cooling fluid piping be installed overhead. Traditional hard copper piping has numerous joints, which raise the risk of leaks within the data center. The use of flexible piping allows the system to be routed overhead without the use of elbows or any intermediate joints from the chilled water source to each InRow RC, greatly reducing the leak and condensation potential in the pipe system. This reduces the concern of users and IT managers with chilled water piping co-located and routed overhead their IT equipment.

High Density

High density areas are caused by consolidation of servers where there is a lack of space or just moving from multiple clusters of servers to a single larger server.

Naturally, this will make the power densities increase, resulting in a higher than average cooling load per rack. The higher cooling demand might require additional CRAC units, and thus require additional fluid lines to be installed. Traditional approaches employ hard copper piping which requires an increase in labor and deployment time when infrastructure demands change.

Coolant Balancing

High density environments demand multiple CRAC units to handle the cooling load required by the IT equipment. To handle this load, multiple fluid lines need to be routed through the data center to the CRACs. Each of the fluid lines employs individual valves that are located in areas that may not be accessible from the data center.

Leased Facilities

Installing a data center in a leased facility is usually not a big issue since the IT equipment can be removed from the racks. However, the actual valves and piping are typically not moved.

The Network Critical Physical Infrastructure (NCPI) must be portable so that it is easily moved to a new location.

A raised floor is not typical in leased facilities. Deploying a NCPI without the use of a raised floor eliminates a one-time expenditure.

APC InfraStruXure Cooling Distribution Unit, The Right Solution

Highly scalable and flexible, the system is capable of growing with your cooling needs as they increase. Each unit comes with isolation/balancing valves for fluid control of each circuit.

Chilled Water Configuration

Chilled water systems utilize water from an APC air cooled modular chiller or a customer supplied chiller for cooling. Chilled water is commonly used in large buildings and can serve multiple indoor units.

- System used with an air cooled modular chiller
- Cost effective for large installations

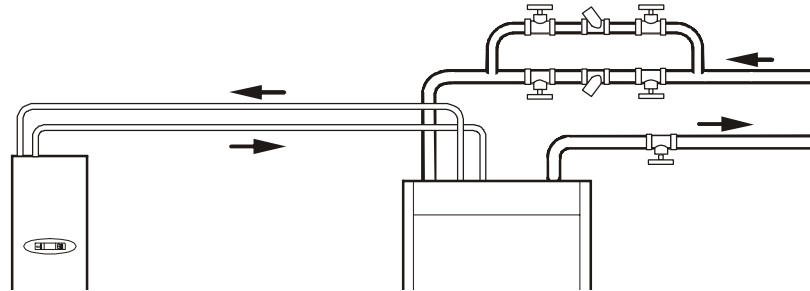

Cooling Distribution Unit Advantages

The Cooling Distribution Unit is capable of adapting easily to increasing cooling loads. The flexible piping reduces the risks of leaks within the data center and has multiple supply and return lines, which allows scalability for medium and large data centers (including high density applications). The CDU also employs a simple centralized fluid distribution strategy, which is easily deployed without adding to the design and installation expenses. The flexible piping that the CDU employs provides a joint-less piping run to the InRow RC.

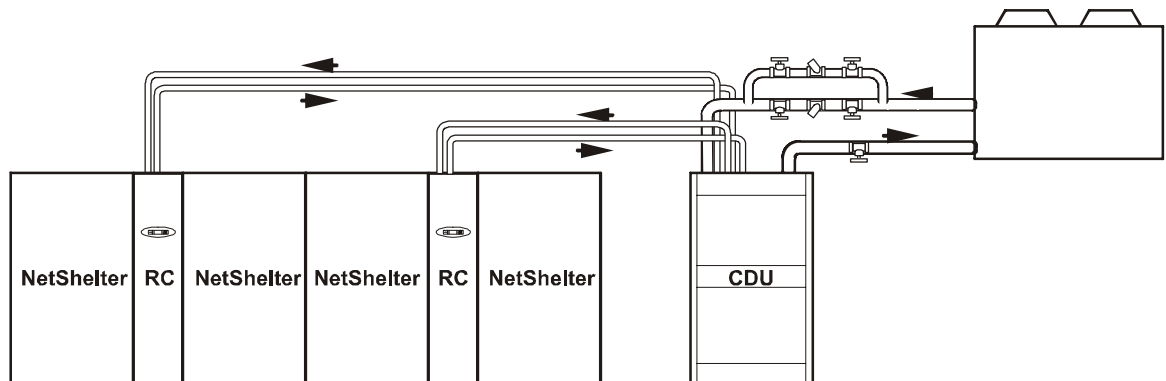

The CDU also provides the flexibility to pipe the main supply and return connections from the chiller from the top (overhead) or the bottom (from a raised floor), regardless of the distribution piping configuration. The CDU will ship with two brass counter flanges for connection of copper mains and two dielectric flanges for connection to steel piping.

In-row Advantages

The in-row solution improves energy efficiency and cooling ability in a number of ways. First, the RC draws air directly from the hot aisle, allowing the RC to take advantage of higher heat transfer efficiency due to higher temperature differences. It can then discharge room temperature air directly in front of the servers it is cooling. This increases energy efficiency by allowing the chiller to operate at higher leaving water temperatures. Also, since the InRow RC never chills the air below its dewpoint, very little if any dehumidification occurs, significantly decreasing water consumption and energy use, and eliminating heat transfer inefficiencies caused by wet coils.

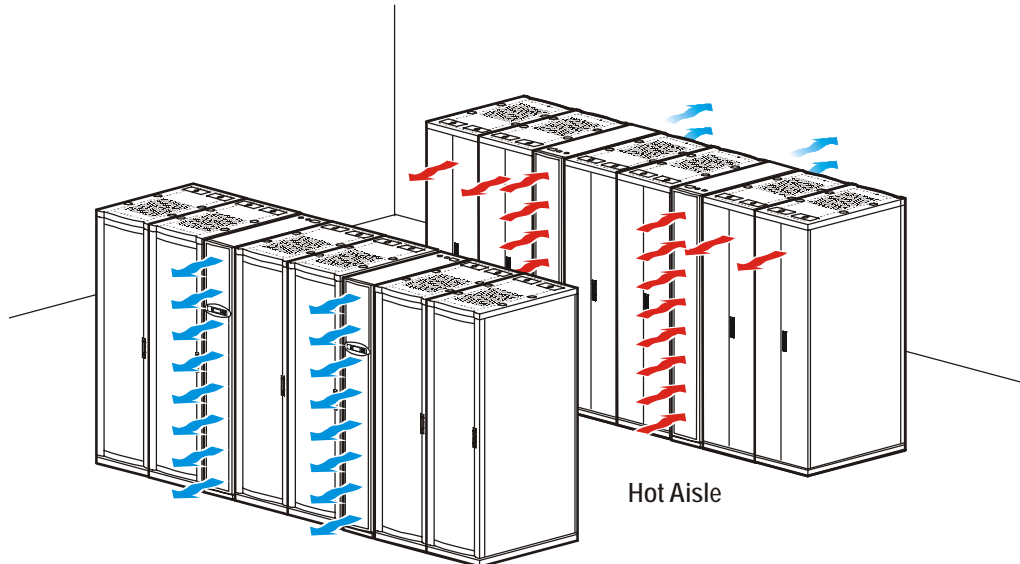

Standard Features



Single Skin Panels

The frame is formed 16 gauge steel bolted together for maximum strength. The cabinet is serviceable from the front and both sides. All exterior panels and corner posts on the frame are powder coated for durability and an attractive finish. Front and back exterior panels are 18 gauge steel and the side exterior panels are 20 gauge steel. The front top and bottom panels are removable for easy access for service and installation.

Isolation and Balancing Valves

Each unit includes balancing / isolation valves on each circuit and isolation valves on the return for servicing. The valves provide coolant flow adjustment in one centralized location

Main Supply and Return Headers

Main supply and return headers supply coolant to the individual supply lines and return coolant to the Air Cooled Modular Chiller.

Multiple Distribution Supply and Return Lines

Up to 12 InRow RC units can be connected to allow scalability, which is required for medium to large data centers. These individual supply and return lines supply coolant to the individual RC units and return coolant to the main header.

Top or Bottom Distribution Piping Connections

Top or bottom connections provide the customer with the option of piping the unit from the top or the bottom, depending on the layout of their data center.

Pipe Fittings

Pipe fittings and couplings, specifically designed for use with PEX-AL-PEX piping, provide a reliable and leak resistant connection between the flexible piping, the CDU, and the RC units.

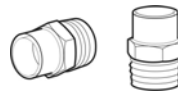

Clamps/Hangers

Clamps secure the piping and permit the use of threaded rods for anchoring. The clamps also provide a clean and organized method for installing piping within the data center.

Jointless Piping

A jointless installation between the CDU and the InRow RC minimizes the potential for leaks, which enables the piping to be installed overhead above the aisles when a raised floor is not available.

Flexible Piping

Flexible piping allows one-time engineering and portability, since the deployment of the piping can be easily modified as the infrastructure demands change.

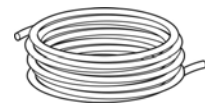

Pipe Insulation

The Cooling Distribution Unit's piping is insulated to prevent condensation. Insulation is also provided for field installation on the piping between the CDU and the InRow RC.

InfraStruXure Model

CDU external components

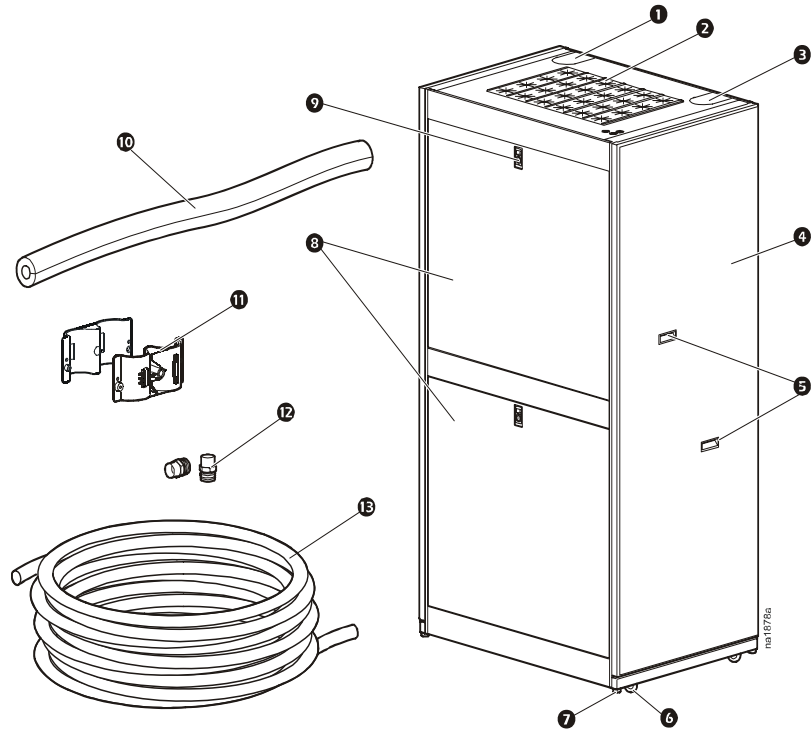

- | | | | |
|---|--------------------------------|---|-----------------------------------------------------------------|
| ❶ | Chiller return (top piping) | ❸ | Front panels |
| ❷ | Pipe pass-through (top piping) | ❹ | Front panel lock |
| ❸ | Chiller supply (top piping) | ❺ | 1.38 in (35.05 mm) x 1/2 in (12.7 mm)
closed cell insulation |
| ❹ | Side panel | ❻ | Pipe clamps |
| ❺ | Lift handle | ❼ | Pipe fittings |
| ❻ | Casters | ❽ | PEX-AL-PEX flexible piping |
| ❼ | Leveling foot | | |

Interior – piping configuration

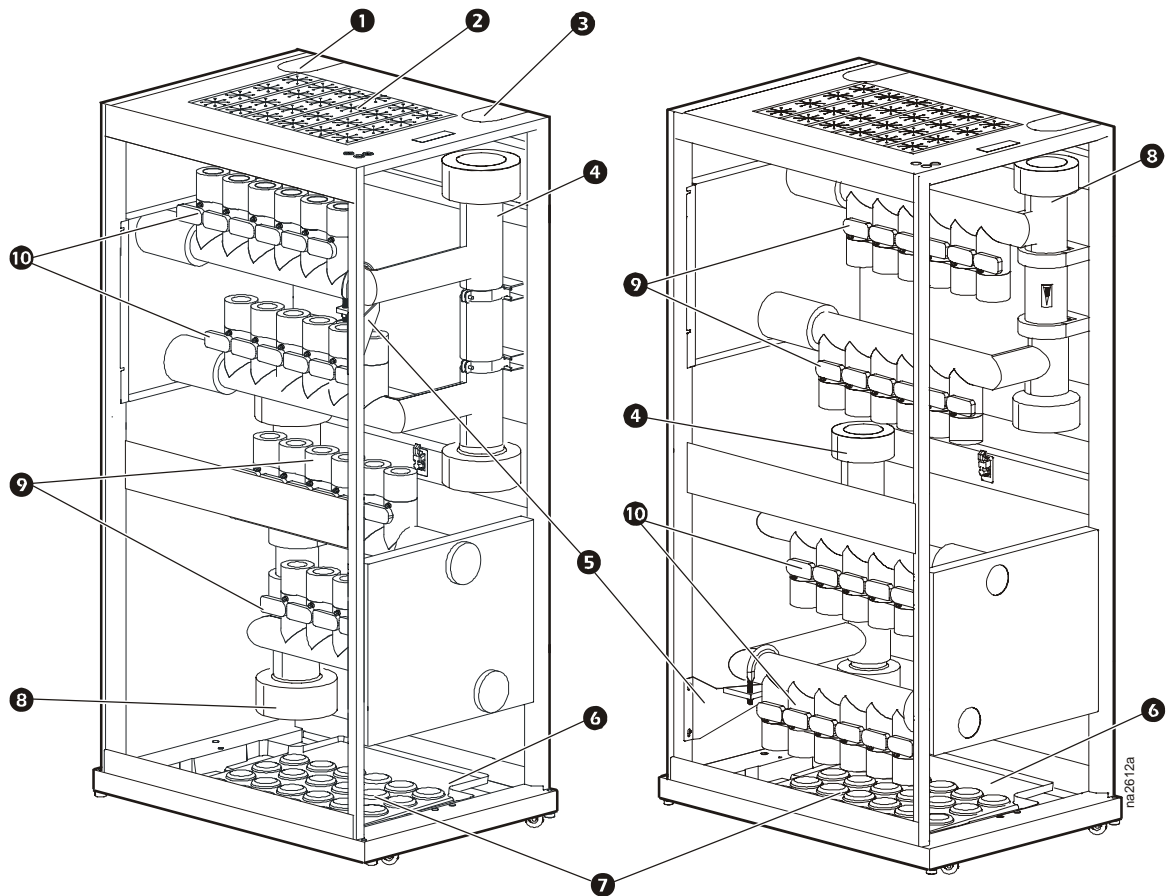

(Panels removed for clarity)

- | | |
|--------------------------------------------------|----------------------------------------------|
| ❶ Top access to chiller return header | ❸ Top access to chiller supply header |
| ❷ Top flexible pipe pass-through | ❹ Chiller supply header |
| ❺ Shipping bracket | ❺ 1-inch full port ball valve (return) |
| ❻ Condensate drain pan | ❻ 1-inch calibrated balancing valve (supply) |
| ❼ Bottom flexible piping pass-through with plugs | |
| ❽ Chiller return header | |

Performance Specifications

PHYSICAL DATA	
Weight — lbs (kg)	
Net Weight	593 (269.55)
Operating Weight	
Shipping Weight	692 (314.55)
Nominal Dimensions — in (mm)*	
Net Height	78.4 (1991)
Shipping Height	85 (2159)
Net Width	42.13 (1070)
Shipping Width	47.99 (1219)
Net Depth	29.53 (750)
Shipping Depth	35 (889)
CONNECTION SIZES — in (mm) — Nominal	
Supply to InRow RC - FTP	1 (25.4)
Return from InRow RC - FTP	1 (25.4)
Main Supply from Chiller** - Flange	3 (76.2)
Main Return from Chiller** - Flange	3 (76.2)
CONTROL VALVES — in (mm) — Nominal	
Isolation Ball Valve	1 (25.4)
Balancing Ball Valve	1 (25.4)
FLOW RATE	
Max Flow Rate of CDU — GPM (l/s)	175 (11.4)
WORKING PRESSURE	
Maximum Working Pressure of CDU — PSI (kPa)	150 (1035)
SCALABILITY	
Maximum # of InRow RCs supported	12
Minimum # of InRow RCs supported	1
Maximum length of PEX Piping between the CDU and InRow RC — ft (m)	150 (45.72)

*See drawings on following pages for actual dimensions

**Connection sizes, not recommended piping sizes

CDU PRESSURE DROP		
Number of InRow RC units supported	Flow Rate through PEX-AL-PEX Piping	Total Pressure Drop
Qty	GPM (l/s)	Feet of Water (kPa)
1-12	2 (0.13)	0.2 (0.6)
1-12	4 (0.25)	0.9 (2.7)
1-12	6 (0.38)	2 (6.0)
1-12	8 (0.50)	3.4 (10.2)
1-12	10 (0.63)	5.3 (15.9)
1-12	12 (0.76)	7.6 (22.7)
1-12	14 (0.88)	10.2 (30.5)
1-10	16 (1.00)	13.3 (39.8)
1-9	18 (1.14)	16.7 (49.9)
1-9	18.5 (1.17)	17.6 (52.6)

PEX-AL-PEX PRESSURE DROP	
Flow Rate through PEX-AL-PEX piping	Pressure Drop through piping / Feet of PEX-AL-PEX
GPM (l/s)	Feet of water/ Feet of pipe (kPa/m)
2 (0.13)	0.004 (0.04)
4 (0.25)	0.01 (0.1)
6 (0.38)	0.03 (0.29)
8 (0.50)	0.05 (0.49)
10 (0.63)	0.07 (0.69)
12 (0.76)	0.1 (0.98)
14 (0.88)	0.13 (1.28)
16 (1.00)	0.17 (1.67)
18 (1.14)	0.21 (2.06)
18.5 (1.17)	0.21 (2.06)

PIPE BEND LENGTH FOR PRESSURE DROP	
Estimated Number of Bends in PEX-AL-PEX	Equivalent Pipe Length
Qty	Ft (m)
1	1 (.31)
2	2 (.61)
3	3 (.92)
4	4 (1.22)
5	5 (1.53)
6	6 (1.83)
7	7 (2.14)
8	8 (2.44)
9	9 (2.75)
10	10 (3.05)

*For Pressure Drop Calculation only. Do not include equivalent pipe length in total PEX-AL-PEX length for installation.

Note: Pressure drop of the system should be based on the highest individual circuit, which is dependent on line length and flow rate.

Sample Pressure Drop Calculation:

Given: GPM = 12

Linear Distance between CDU and RC = 80 ft

Estimated Number of Bends in Piping from CDU to RC = 10 (5 Supply, 5 Return)

Step 1: Determine total PEX-AL-PEX length for pressure drop calculation

PEX-AL-PEX length = 80 ft (supply) + 80 ft (return) = 160 ft

Equivalent PEX-AL-PEX length for bends = 10 ft (10 bends = 10 ft) (from Pipe Bend Length table)

Total PEX-AL-PEX length for pressure drop calculation = 160 ft + 10 ft = 170 ft

Step 2: Determine pressure drop of PEX-AL-PEX piping (including bends)

Pressure drop of PEX-AL-PEX = 0.1 ft of water/ft of PEX-AL-PEX at 12 GPM

(from PEX-AL-PEX Pressure Drop table)

Total pressure drop of PEX-AL-PEX for 170 ft = 0.1 ft of water/ft of PEX-AL-PEX * 170 ft = 17 ft of water

Step 3: Determine pressure drop of CDU

Pressure drop of CDU = 7.6 ft of water at 12 GPM (from CDU Pressure Drop table)

Step 4: Determine total pressure drop of PEX-AL-PEX and CDU

Total pressure drop of PEX-AL-PEX and CDU = 17ft of water + 7.6 ft of water = 24.6 ft of water

Dimensional Data

InfraStruXure CDU Assembled Module

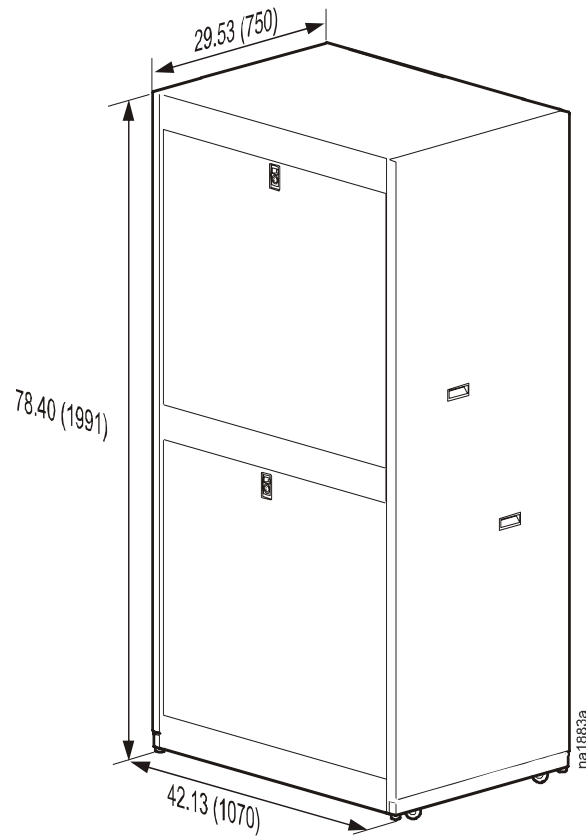

Note: All dimensions are in inches (millimeters).

Note: Minimum clearance for overhead piping is 18 inches (457.2 millimeters) from top of CDU.

Minimum raised floor height for bottom piping is 12 inches (304.8 millimeters).

Piping Connection

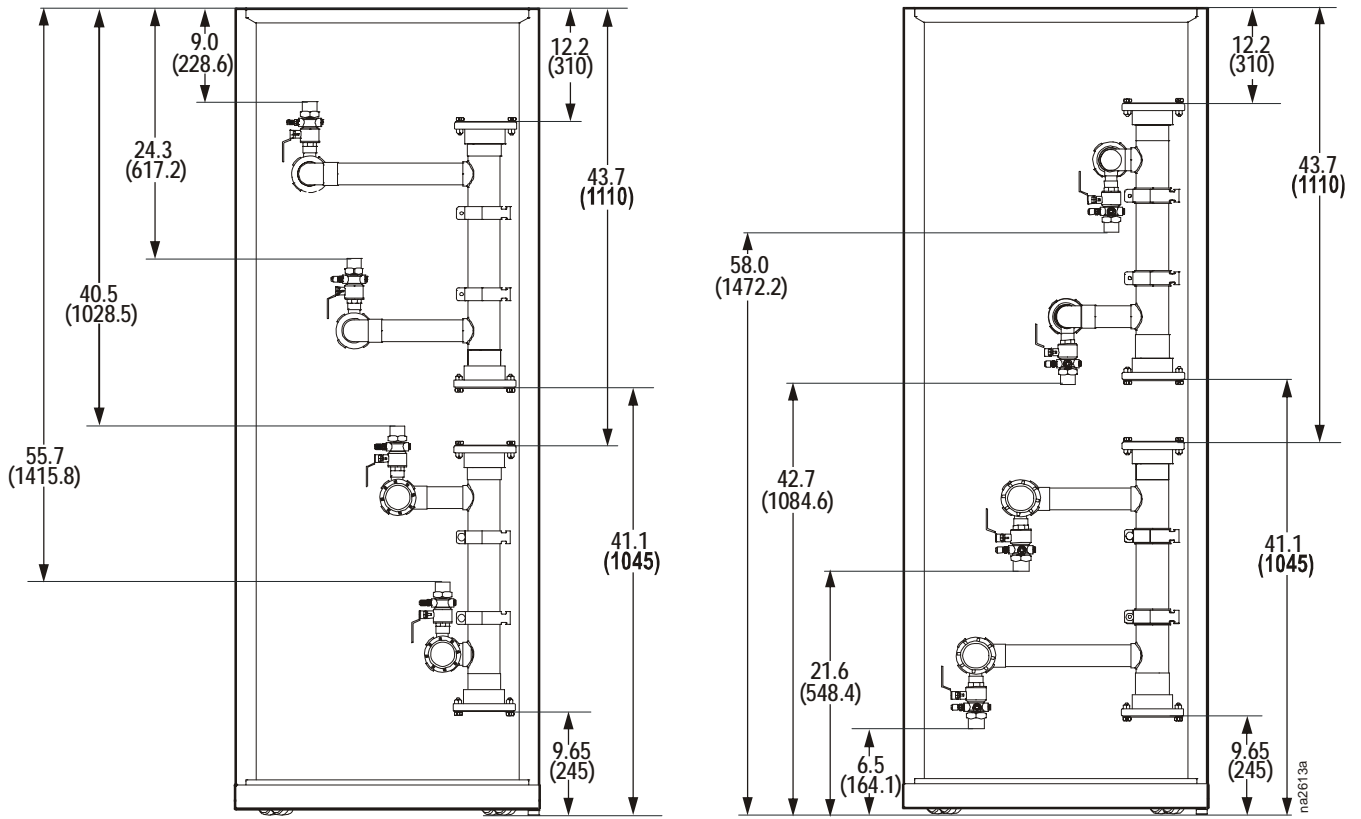

Note: All dimensions are inches (millimeters)

Guide Specifications

PART 1 —

1.01 SUMMARY

These specifications describe requirements for a system designed for cooling distribution to modular InRow RC air conditioners. The system shall be designed to distribute and balance the chilled water / glycol using flexible jointless piping to the air conditioners. The manufacturer shall design and furnish all the piping and fittings required for cooling distribution from the distribution unit to the InRow RC units.

1.02 DESIGN REQUIREMENTS

- A. The cooling distribution unit, manufactured by APC, shall include a supply and return distribution manifold. Each manifold should include 12 pipe branches with shut-off and balancing valves. The unit shall be as described in the following specification as manufactured by APC.
 - 1. Model number:
 - 2. Total number of InRow RC units:
 - 3. Flow per circuit: (gpm)
 - 4. Water pressure drop through the CDU:
- B. The unit shall be factory-assembled with isolation and balancing valves and shall be designed to be used with jointless flexible piping.

1.03 SUBMITTALS

Submittals shall be provided with the proposal and shall include: overall dimensions of the unit, total of circuits used, maximum chilled water/glycol flow per circuit, calculated run of flexible piping per circuit, and piping connection drawings at the CDU and at the InRow RC.

1.04 QUALITY ASSURANCE

- A. The unit shall be factory tested prior to shipment. Testing shall include complete pressure and leak testing to ensure system integrity. The system shall be inspected for quality control before shipment.
- B. The unit shall be UL Listed to UL 1995 and CSA C22.2 No. 236.

1.05 WARRANTY

The system parts shall be provided with a warranty against defects for a period of 12 months from date of shipment from the factory.

PART 2 —

2.01 STANDARD COMPONENTS

A. Cabinet Construction

1. The frame shall be 16 gauge formed steel and bolted together.
2. The front and back exterior panels shall be 18 gauge steel and the side exterior panels shall be 20 gauge steel.
3. All exterior panels and corner posts on the frame shall be powder coated black. The unit shall include front removable panels to allow access for system balancing and service and side removable panels to allow for main piping connections.
4. The front panels shall have provisions to be locked with a key.
5. The unit shall include casters for easy installation and leveling feet at each corner.
6. All piping, including headers and distribution lines, shall be insulated with 1/2 in (12.7 mm) closed cell insulation.

B. Connections

The main supply line can be piped from either the top or bottom of the unit. The distribution lines are dependent on the version of the unit: top piped or bottom piped. The dielectric flanges allow the unit to be connected to the building chilled water system using copper or iron piping.

C. Valves

1. Each supply branch shall be 1 in (25.4 mm) I.D. and shall include a balancing and shut-off valve to provide a single point of balancing at the distribution unit.
2. Each return branch shall be 1 in (25.2 mm) I.D. and shall include a ball valve for isolation.
3. A 1/4 in (6.35 mm) male flare port with Schrader valve shall be included in each supply and return branch for pressure test and drain.

D. Drain Pan

A drain pan with a 1/4 in (6.35 mm) plastic tube connection shall be included at the bottom of the unit.

E. Flexible Piping

1. Jointless flexible piping shall be used for chilled water/glycol distribution from the CDU to the InRow RC units.
2. The piping shall be crosslinked polyethylene/aluminum/crosslinked polyethylene tubing (PEX-AL-PEX) manufactured by PEX-b method.
3. The temperature and pressure ratings of the piping shall be: 200°F (93.3°C) at 100 psi (689.5 kPa), 180°F (82.2°C) at 125 psi (861.8 kPa), and 73°F (22.8°C) at 200 psi (1378.9 kPa).

4. Piping shall conform with ASTM Standard: ASTM E814, ASTM F1281, and NSF Standard: NSF-PW 14 and 61.
5. Piping length shall not exceed 150 ft (45.72 m) from the CDU to the air conditioner and it shall only include fittings at the CDU and at the InRow RC.
6. Pipe connections to the CDU and InRow RC shall be made with pipe fittings that are crimped at each connection to ensure no leakage in the system.
7. All PEX-AL-PEX piping shall be insulated in the field with 1/2 in (12.7 mm) closed cell insulation.

F. Pipe Clamps

1. Pipe clamps shall be factory provided and field installed at least every 32 in (812.8 mm) when piping is installed overhead to properly secure the PEX-AL-PEX piping to the ceiling. (Refer to local codes for exact spacing requirements.)
2. The clamps shall include a center hole that permits the use of a 3/8 in (9.5 mm) threaded rod for anchoring.

G. Insulation

Insulation shall be 1.38 in (35.05 mm) in diameter by 1/2 in (12.7 mm) thick closed cell insulation.

PART 3 —

3.01 IMPLEMENTATION

A. Installation

1. Installation of the system shall be in accordance to the Guidelines for Installation by the manufacturer.
2. Installation shall be performed by the manufacturer or supervised by the manufacturer's service representative.
3. Installation of piping and connections from the Cooling Distribution Unit to the InRow RC units shall be performed by the manufacturer or supervised by the manufacturer's service representative.

Note: The minimum clearance for overhead piping is 18 in (457.2 mm) from the top of the CDU to the ceiling. The minimum raised floor height for units configured for bottom piping is 12 in (304.8 mm).

B. Start-up

Start-up of the Cooling Distribution Unit shall be performed by the manufacturer.

Guidelines for Installation

The CDU provides reliable and flexible fluid distribution to the InRow RC in medium to large data centers (including high density applications). The unit incorporates flexible and jointless piping to provide you with a scalable fluid distribution system that minimizes the risk of leaks within the data center.

The CDU will provide years of trouble-free service, when installed by technically qualified personnel.

Service Access

The InfraStruXure CDU is designed to be a stand-alone unit. It can be placed against a wall or in any open area that is suitable for use. Both side and front panels may be removed during the installation process. An area of 36 in (915 mm) of clear floor space in front and 24 in (609.5 mm) at each side of the unit is required for installation. For service, an area of 36 in (914 mm) of clear floor space in front of the CDU is required. All required maintenance can be performed from the front of the unit.

Receiving the unit

Your CDU has been completely tested and inspected prior to shipment. To ensure that you have received the unit in excellent condition, perform a careful inspection of the crating and the unit immediately upon receipt. Verify that all parts ordered were received as specified. Report any damage discovered to the freight carrier. If necessary, contact the APC field service department for help in repairing or replacing damaged parts. While APC is not responsible for damage incurred in transit, we want to make sure that you have no undue delays in your system start-up.

Rigging

The unit is manufactured with a formed steel frame for maximum strength and unit integrity. However, as with all electrical and mechanical equipment, you must take care with proper rigging of your unit.

When using a forklift to move the unit, use the shipping skid to protect the bottom of the unit. When using chains, cables or rope to lift the unit, use spreader bars to prevent damage to the finished panels.

Note: Due to the ongoing program dedicated to product improvement, specifications are subject to revisions without notice. APC assumes no responsibility, and disclaims all liability for damages resulting from use of this information or for any errors or omissions.

APC Worldwide Customer Support

Customer support for this or any other APC product is available at no charge in any of the following ways:

- Visit the APC Web site to access documents in the APC Knowledge Base and to submit customer support requests.
 - **www.apc.com** (Corporate Headquarters)
Connect to localized APC Web sites for specific countries, each of which provides customer support information.
 - **www.apc.com/support/**
Global support searching APC Knowledge Base and using e-support.
- Contact an APC Customer Support center by telephone or e-mail.

Regional centers

APC headquarters U.S., Canada	(1)(800)800-4272 (toll free)
Latin America	(1)(401)789-5735 (USA)
Europe, Middle East, Africa	(353)(91)702020 (Ireland)
Asia Pacific	(61) (2) 9955 9366 (Australia)

- Local, country-specific centers: go to **www.apc.com/support/contact** for contact information.

Contact the APC representative or other distributor from whom you purchased your APC product for information on how to obtain local customer support.

Entire contents copyright 2007 American Power Conversion Corporation. All rights reserved. Reproduction in whole or in part without permission is prohibited. APC, the APC logo, InfraStruXure, and NetworkAIR are trademarks of American Power Conversion Corporation. All other trademarks, product names, and corporate names are the property of their respective owners and are used for informational purposes only.

