



Maintenance & Service Guide

HP TouchSmart 9300 Elite All-in-One Business
PC

© Copyright 2011 Hewlett-Packard Development Company, L.P. The information contained herein is subject to change without notice.

Microsoft and Windows are trademarks of Microsoft Corporation in the U.S. and other countries.

The only warranties for HP products and services are set forth in the express warranty statements accompanying such products and services. Nothing herein should be construed as constituting an additional warranty. HP shall not be liable for technical or editorial errors or omissions contained herein.

This document contains proprietary information that is protected by copyright. No part of this document may be photocopied, reproduced, or translated to another language without the prior written consent of Hewlett-Packard Company.

Maintenance & Service Guide

HP TouchSmart 9300 Elite All-in-One Business PC

First Edition (December 2011)

Document Part Number: 654196-002

About This Book

 **WARNING!** Text set off in this manner indicates that failure to follow directions could result in bodily harm or loss of life.

 **CAUTION:** Text set off in this manner indicates that failure to follow directions could result in damage to equipment or loss of information.

 **NOTE:** Text set off in this manner provides important supplemental information.

Table of contents

| | |
|-----------------------------------------------------------------------------------|-----------|
| 1 Product Features | 1 |
| Front Components | 3 |
| Side Components | 4 |
| Rear Components | 5 |
| 2 Installing and Customizing the Software | 6 |
| Installing the Operating System | 6 |
| Downloading Microsoft Windows Updates | 6 |
| Installing or Upgrading Device Drivers (Windows systems) | 7 |
| Protecting the Software | 7 |
| 3 Computer Setup (F10) Utility | 8 |
| Computer Setup (F10) Utilities | 8 |
| Using Computer Setup (F10) Utilities | 9 |
| Computer Setup—File | 9 |
| Computer Setup—Storage | 11 |
| Computer Setup—Security | 12 |
| Computer Setup—Power | 15 |
| Computer Setup—Advanced | 16 |
| 4 Serial ATA (SATA) Drive Guidelines and Features | 17 |
| SATA Hard Drives | 17 |
| SATA Hard Drive Cables | 17 |
| SATA Data Cable | 17 |
| SMART ATA Drives | 18 |
| Hard Drive Capacities | 18 |
| 5 Identifying the Chassis, Routine Care, and Disassembly Preparation | 19 |
| Chassis Designation | 19 |
| All-in One | 19 |
| Electrostatic Discharge Information | 20 |

| | |
|----------------------------------------------------|-----------|
| Generating Static | 20 |
| Preventing Electrostatic Damage to Equipment | 20 |
| Personal Grounding Methods and Equipment | 21 |
| Grounding the Work Area | 21 |
| Recommended Materials and Equipment | 21 |
| Operating Guidelines | 22 |
| Routine Care | 23 |
| General Cleaning Safety Precautions | 23 |
| Cleaning the Computer Case | 23 |
| Cleaning the Keyboard | 23 |
| Cleaning the Monitor | 24 |
| Cleaning the Mouse | 24 |
| Service Considerations | 24 |
| Tools and Software Requirements | 24 |
| Screws | 24 |
| Cables and Connectors | 25 |
| Hard Drives | 25 |
| Lithium Coin Cell Battery | 25 |
| 6 Illustrated parts catalog | 26 |
| Computer major components | 26 |
| Boards | 29 |
| Cables | 30 |
| Sequential part number listing | 30 |
| 7 Removal and Replacement Procedures | 34 |
| Preparing to disassemble the computer | 34 |
| Stand | 35 |
| VESA mount | 37 |
| Rear panels | 47 |
| Installing memory | 50 |
| DDR3-SDRAM SODIMMs | 50 |
| Populating SODIMM sockets | 51 |
| Installing SODIMMS | 52 |
| Hard drive | 54 |
| Inverter board | 57 |
| Optical drive connector board | 59 |
| Left cap | 61 |
| Optical drive | 63 |
| Optical drive eject board | 65 |
| Right cap | 67 |

| | |
|-----------------------------------------------------------------------|------------|
| Volume button board | 70 |
| Rear logo cover | 72 |
| Webcam module | 73 |
| Main rear frame | 75 |
| Power button board | 76 |
| System board shield | 77 |
| Speakers | 79 |
| Infrared sensor board | 81 |
| Fan | 83 |
| Fan sink (Thermal module) | 85 |
| Processor | 86 |
| Hard drive connector | 89 |
| Graphics board | 91 |
| WLAN module and TV tuner module | 93 |
| System board | 96 |
| Display panel | 98 |
| G-sensor board | 100 |
| Appendix A POST Error Messages | 102 |
| POST Numeric Codes and Text Messages | 103 |
| Interpreting POST Diagnostic Front Panel LEDs and Audible Codes | 110 |
| Appendix B Troubleshooting Without Diagnostics | 113 |
| Safety and Comfort | 113 |
| Solving General Problems | 114 |
| Solving Power Problems | 117 |
| Solving Diskette Problems | 118 |
| Solving Hard Drive Problems | 121 |
| Solving Media Card Reader Problems | 124 |
| Solving Display Problems | 126 |
| Solving Audio Problems | 129 |
| Solving Printer Problems | 131 |
| Solving Keyboard and Mouse Problems | 132 |
| Solving Hardware Installation Problems | 134 |
| Solving Network Problems | 136 |
| Solving Memory Problems | 140 |
| Solving Processor Problems | 141 |
| Solving CD-ROM and DVD Problems | 142 |
| Solving USB Flash Drive Problems | 144 |
| Solving Internet Access Problems | 145 |
| Solving Software Problems | 148 |

| | |
|-----------------------------------------------------|------------|
| Contacting Customer Support | 149 |
| Appendix C Connector Pin Assignments | 150 |
| Ethernet BNC | 150 |
| USB | 150 |
| Microphone | 150 |
| Headphone | 151 |
| Line-in Audio | 151 |
| Line-out Audio | 151 |
| Appendix D Power Cord Set Requirements | 152 |
| General Requirements | 152 |
| Japanese Power Cord Requirements | 152 |
| Country-Specific Requirements | 153 |
| Appendix E Specifications | 154 |
| All-in One Models | 154 |
| Index | 156 |

1 Product Features

Figure 1-1 HP TouchSmart 9300 Elite Business PC



NOTE: The wireless keyboard and mouse shown above are optional accessories.

The HP TouchSmart 9300 Elite Business PC offers the following features:

- Integrated All-in-One form factor
- 23-inch diagonal widescreen WLED backlit BrightView LCD
- Multitouch panel
- Swivel pad and VESA mounting bracket under base of stand
- Adjustable reclining stand
- Intel® 2nd Generation Core™ i7, i5, or i3 processor
- Intel H67 chipset
- Genuine Windows 7 Professional Edition operating system
- Integrated Intel HD Graphics, or discrete MXM graphics
- Integrated Gigabit Network Connection (10/100/1000 NIC)

- Optional wireless connectivity:
 - Integrated 802.11 a/b/g/n or b/g/n wireless LAN module
 - Bluetooth® 3.0
- Optional TV Tuner
- Four SODIMM slots with up to 16 GB of DDR3 SDRAM memory and dual channel support
- Up to 1 TB hard drive, or up to 300 GB Solid State Drive
- Optional Slot-load Blu-ray Combo Drive (Blu-ray Reader/DVD Burner) or SuperMulti DVD LightScribe Burner
- 6-in-1 Media Card Reader
- 7 USB ports
- DisplayPort
- Integrated Full HD webcam, dual microphone array, and premium stereo speakers
- Volume control and mute buttons
- Security lock slot and rear port security cover
- Removable panels on the back of the chassis allow administrators to easily and efficiently service the PC
- HP TouchSmart software suite for instant access to calendar, Internet, notes, and multimedia content
- ENERGY STAR® qualified, EPEAT® Gold registered, and offers 90-percent energy-efficient power
- Choice of wired or wireless keyboard and mouse

Front Components

Figure 1-2 Front Components

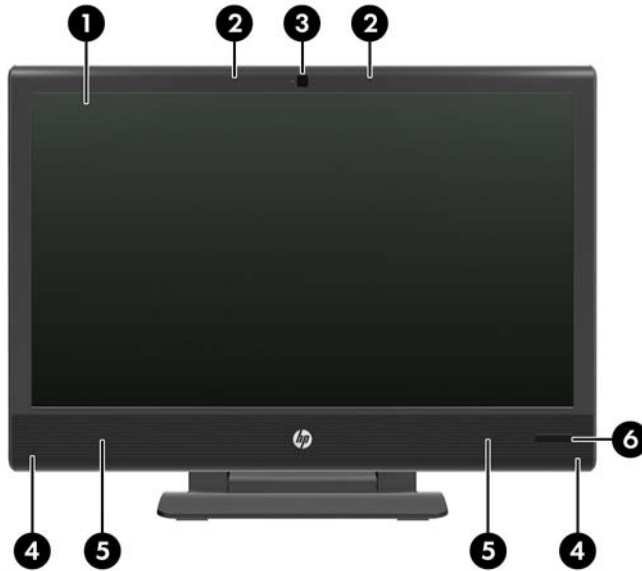

Table 1-1 Front Components

| No. | Component | No. | Component |
|-----|----------------------------------------------------------------------------------------------------|-----|----------------------------------|
| 1 | 58.4 cm (23-inch) diagonal, 16:9 widescreen, touch-enabled, full HD, white LED backlit LCD display | 4 | Dual wireless antenna |
| 2 | Dual microphone array (optional) | 5 | High-performance stereo speakers |
| 3 | Webcam (optional) | 6 | IR Receiver (select models only) |

Side Components

Figure 1-3 Side Components

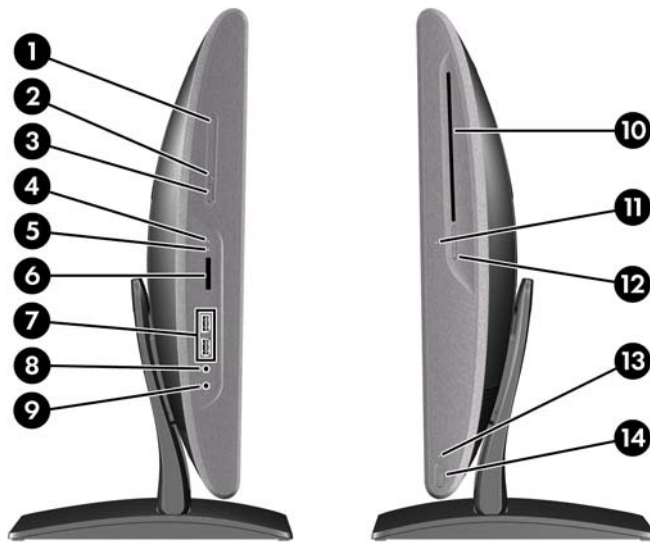

Table 1-2 Side Components

| No. | Component | No. | Component |
|-----|--------------------------------|-----|------------------------------------|
| 1 | Volume up button | 8 | Microphone/line in jack |
| 2 | Volume down button | 9 | Headphone jack |
| 3 | Mute button | 10 | Slot-load optical drive (optional) |
| 4 | Hard drive activity LED | 11 | Optical drive eject button |
| 5 | Media card reader activity LED | 12 | Optical drive activity LED |
| 6 | Media card reader | 13 | Power LED |
| 7 | (2) USB 2.0 ports | 14 | Power button |

Rear Components

Figure 1-4 Rear Components

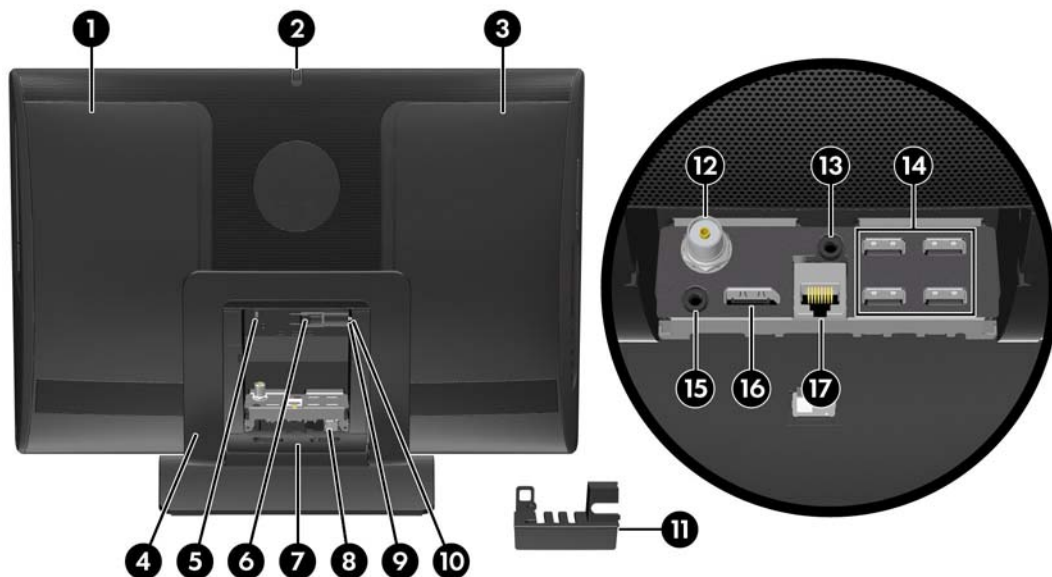



Table 1-3 Rear Components

| No. | Component | No. | Component |
|-----|--------------------------------------------------------|-----|----------------------------------------|
| 1 | Drive access panel | 10 | Power indicator light |
| 2 | Webcam adjustment wheel | 11 | Rear port security cover |
| 3 | Memory access panel | 12 | TV coax in (optional) |
| 4 | Adjustable reclining stand | 13 | IR Emitter (Blaster) output (optional) |
| 5 | Security lock slot | 14 | (4) USB 2.0 ports |
| 6 | Power connector release latch | 15 | Audio line out |
| 7 | Rear port access door | 16 | DisplayPort |
| 8 | USB port for optional wireless keyboard/mouse receiver | 17 | RJ-45 Gigabit Ethernet port |
| 9 | Power connector | | |

2 Installing and Customizing the Software

If your computer was not shipped with a Microsoft operating system, some portions of this documentation do not apply. Additional information is available in online help after you install the operating system.

 **NOTE:** If the computer was shipped with Windows Vista or Windows 7 loaded, you will be prompted to register the computer with HP Total Care before installing the operating system. You will see a brief movie followed by an online registration form. Fill out the form, click the **Begin** button, and follow the instructions on the screen.

 **CAUTION:** Do not add optional hardware or third-party devices to the computer until the operating system is successfully installed. Doing so may cause errors and prevent the operating system from installing properly.

 **NOTE:** Be sure there is a 10.2-cm (4-inch) clearance at the back of the unit and above the monitor to permit the required airflow.

Installing the Operating System

The first time you turn on the computer, the operating system is installed automatically. This process takes about 5 to 10 minutes, depending on which operating system is being installed. Carefully read and follow the instructions on the screen to complete the installation.

 **CAUTION:** Once the automatic installation has begun, **DO NOT TURN OFF THE COMPUTER UNTIL THE PROCESS IS COMPLETE.** Turning off the computer during the installation process may damage the software that runs the computer or prevent its proper installation.

 **NOTE:** If the computer shipped with more than one operating system language on the hard drive, the installation process could take up to 60 minutes.

If your computer was not shipped with a Microsoft operating system, some portions of this documentation do not apply. Additional information is available in online help after you install the operating system.

Downloading Microsoft Windows Updates

1. To set up your Internet connection, click **Start > Internet Explorer** and follow the instructions on the screen.
2. Once an Internet connection has been established, click the **Start** button.

3. Select the **All Programs** menu.
4. Click on the **Windows Update** link.

In Windows 7, the **Windows Update** screen appears. Click **view available updates** and make sure all critical updates are selected. Click the **Install** button and follow the instructions on the screen.

It is recommended that you install all of the critical updates and service packs.

5. After the updates have been installed, Windows will prompt you to reboot the machine. Be sure to save any files or documents that you may have open before rebooting. Then select **Yes** to reboot the machine.

Installing or Upgrading Device Drivers (Windows systems)

When installing optional hardware devices after the operating system installation is complete, you must also install the drivers for each of the devices.

If prompted for the i386 directory, replace the path specification with `C:\i386`, or use the **Browse** button in the dialog box to locate the i386 folder. This action points the operating system to the appropriate drivers.

Obtain the latest support software, including support software for the operating system from <http://www.hp.com/support>. Select your country and language, select **Download drivers and software (and firmware)**, enter the model number of the computer, and press **Enter**.

Protecting the Software

To protect the software from loss or damage, keep a backup copy of all system software, applications, and related files stored on the hard drive. Refer to the operating system or backup utility documentation for instructions on making backup copies of your data files.

3 Computer Setup (F10) Utility

Computer Setup (F10) Utilities

Use Computer Setup (F10) Utility to do the following:

- Change factory default settings.
- Set the system date and time.
- Set, view, change, or verify the system configuration, including settings for processor, graphics, memory, audio, storage, communications, and input devices.
- Modify the boot order of bootable devices such as hard drives, optical drives, or USB flash media devices.
- Enable Quick Boot, which is faster than Full Boot but does not run all of the diagnostic tests run during a Full Boot. You can set the system to:
 - always Quick Boot (default);
 - periodically Full Boot (from every 1 to 30 days); or
 - always Full Boot.
- Select Post Messages Enabled or Disabled to change the display status of Power-On Self-Test (POST) messages. Post Messages Disabled suppresses most POST messages, such as memory count, product name, and other non-error text messages. If a POST error occurs, the error is displayed regardless of the mode selected. To manually switch to Post Messages Enabled during POST, press any key (except **F1** through **F12**).
- Establish an Ownership Tag, the text of which is displayed each time the system is turned on or restarted.
- Enter the Asset Tag or property identification number assigned by the company to this computer.
- Enable the power-on password prompt during system restarts (warm boots) as well as during power-on.
- Establish a setup password that controls access to the Computer Setup (F10) Utility and the settings described in this section.
- Secure integrated I/O functionality, including USB, audio, or embedded NIC, so that they cannot be used until they are unsecured.
- Enable or disable removable media boot ability.

- Solve system configuration errors detected but not automatically fixed during the Power-On Self-Test (POST).
- Replicate the system setup by saving system configuration information on a USB flash drive and restoring it on one or more computers.
- Execute self-tests on a specified ATA hard drive (when supported by drive).
- Enable or disable DriveLock security (when supported by drive).

Using Computer Setup (F10) Utilities

Computer Setup can be accessed only by turning the computer on or restarting the system. To access the Computer Setup Utilities menu, complete the following steps:

1. Turn on or restart the computer.
2. Press **Esc** while the “Press the ESC key for Startup Menu” message is displayed at the bottom of the screen.

 **NOTE:** If you do not press **Esc** at the appropriate time, you must restart the computer and again press **Esc** when the monitor light turns green to access the utility.

3. Press **F10** to enter Computer Setup.
4. A choice of five headings appears in the Computer Setup Utilities menu: File, Storage, Security, Power, and Advanced.
5. Use the arrow (left and right) keys to select the appropriate heading. Use the arrow (up and down) keys to select the option you want, then press **Enter**. To return to the Computer Setup Utilities menu, press **Esc**.
6. To apply and save changes, select **File > Save Changes and Exit**.
 - If you have made changes that you do not want applied, select **Ignore Changes and Exit**.
 - To reset to factory settings or previously saved default settings (some models), select **Apply Defaults and Exit**. This option will restore the original factory system defaults.

 **CAUTION:** Do NOT turn the computer power OFF while the BIOS is saving the Computer Setup (F10) changes because the CMOS could become corrupted. It is safe to turn off the computer only after exiting the F10 Setup screen.

Computer Setup—File

 **NOTE:** Support for specific Computer Setup options may vary depending on the hardware configuration.

Table 3-1 Computer Setup—File

| Option | Description |
|--------|-------------|
|--------|-------------|

Table 3-1 Computer Setup—File (continued)

| | |
|--------------------------------|-------------------------------------------------------------------------------------------------------------------------------------------------------------------------------------------------------------------------------------------------------------------------------------------------------------------------------------------------------------------------------------------------------------------------------------------------|
| System Information | Lists: <ul style="list-style-type: none">• Product name• SKU number (some models)• Processor type/speed/stepping• Cache size (L1/L2/L3)• Installed memory size/speed, number of channels (single or dual) (if applicable)• Integrated MAC address for embedded, enabled NIC (if applicable)• System BIOS (includes family name and version)• Chassis serial number |
| About | Displays copyright notice. |
| Set Time and Date | Allows you to set system time and date. |
| Apply Defaults and Exit | Applies the currently selected default settings and clears any established passwords. |
| Ignore Changes and Exit | Exits Computer Setup without applying or saving any changes. |
| Save Changes and Exit | Saves changes to system configuration or default settings and exits Computer Setup. |

Computer Setup—Storage



NOTE: Support for specific Computer Setup options may vary depending on the hardware configuration.

Table 3-2 Computer Setup—Storage

| Option | Description |
|-----------------------------|---------------------------------------------------------------------------------------------------------------------------------------------------------------------------------------------------------------------------------------------------------------------------------------------------------------------------------------------------------------------------------------------------------------------------------------------------------------------------------------------------------------------------------------------------------------------------------------------------------------------------------------------------------------------------------------------------------------------------------------------------------------------------------------------------------------------------------------------------------------------------------------------------------------------------------------------------------------------------------------------------------------------------------------------------------------------------------------------------------------------------------------------------------------------------------------------------------------------|
| Device Configuration | <p>Lists all installed BIOS-controlled storage devices.</p> <p>When a device is selected, detailed information and options are displayed. The following options may be presented:</p> <p>Hard Disk: Size, model, firmware, serial number, emulation type.</p> <p>Emulation type has the following choices:</p> <ul style="list-style-type: none">• None (prevents BIOS data accesses and disables it as a boot device)• Hard Disk (treated as a hard disk) <p>CD-ROM: Model, firmware, serial number, connector color. No emulation options available.</p> |
| Storage Options | <p>SATA Emulation</p> <p>Allows you to choose how the SATA controller and devices are accessed by the operating system. There are two supported options: AHCI and IDE.</p> <p>AHCI (default option) - Allows operating systems with AHCI device drivers loaded to take advantage of more advanced features of the SATA controller.</p> <p>IDE - This is the most backwards-compatible setting of the two options. Operating systems usually do not require additional driver support in IDE mode.</p> <p>NOTE: The AHCI device driver must be installed prior to attempting to boot from an AHCI volume. If you attempt to boot from an AHCI volume without the required device driver installed, the system will crash (blue screen).</p> |
| DPS Self-Test | <p>Allows you to execute self-tests on ATA hard drives capable of performing the Drive Protection System (DPS) self-tests.</p> <p>NOTE: This selection will only appear when at least one drive capable of performing the DPS self-tests is attached to the system.</p> |
| Boot Order | <p>Allows you to:</p> <ul style="list-style-type: none">• Specify the order in which attached devices (such as a USB flash media device, hard drive, optical drive, or network interface card) are checked for a bootable operating system image. Each device on the list may be individually excluded from or included for consideration as a bootable operating system source.• Specify the order of attached hard drives. The first hard drive in the order will have priority in the boot sequence and will be recognized as drive C (if any devices are attached). <p>NOTE: MS-DOS drive lettering assignments may not apply after a non-MS-DOS operating system has started.</p> <p>Shortcut to Temporarily Override Boot Order</p> <p>To boot one time from a device other than the default device specified in Boot Order, restart the computer and press F9 before the computer boots to the operating system. After POST is completed, a list of bootable devices is displayed. Use the arrow keys to select the preferred bootable device and press Enter. The computer then boots from the selected non-default device for this one time.</p> |

Computer Setup—Security



NOTE: Support for specific Computer Setup options may vary depending on the hardware configuration.

Table 3-3 Computer Setup—Security

| Option | Description |
|--------------------------|-----------------------------------------------------------------------------------------------------------------------------------------------------------------------------------------------------------------------------------------------------------------------------------------------------------------------------------------------------------------------------------------------------------------------------------------------------------------------------------------------------------------------------------------------------|
| Setup Password | <p>Allows you to set and enable a setup (administrator) password.</p> <p>NOTE: If the setup password is set, it is required to change Computer Setup options, flash the ROM, and make changes to certain plug and play settings under Windows.</p> <p>See the <i>Desktop Management Guide</i> for more information.</p> |
| Power-On Password | <p>Allows you to set and enable a power-on password. The power-on password prompt appears after a power cycle. If the user does not enter the correct power-on password, the unit will not boot.</p> <p>NOTE: This password does not appear on warm boots , such as Ctrl+Alt+Delete or Restart from Windows, unless enabled in Password Options (see below).</p> <p>See the <i>Desktop Management Guide</i> for more information.</p> |
| Device Security | <p>Allows you to set Device Available/Device Hidden for:</p> <ul style="list-style-type: none">• System audio• Network controllers (some models)• SATA0• SATA1• SATA2 |
| USB Security | <p>Allows you to enable or disable groups of USB ports or individual USB ports:</p> <ul style="list-style-type: none">• Front USB Ports<ul style="list-style-type: none">◦ USB Port 4◦ USB Port 5• Rear USB Ports<ul style="list-style-type: none">◦ USB Port 0◦ USB Port 1◦ USB Port 2◦ USB Port 3• internal USB Ports<ul style="list-style-type: none">◦ USB Port 6◦ USB Port 8◦ USB Port 9◦ USB Port 10 |

Table 3-3 Computer Setup—Security (continued)

| | |
|----------------------|-------------------------------------------------------------------------------------------------------------------------------------------------------------------------------------------------------------------------------------------------------------------------------------------------------------------------------------------------------------------------------------------------------------------------------------------------------------|
| | <ul style="list-style-type: none">◦ USB Port 11◦ USB Port 13 |
| Slot Security | Allows you to disable or enable any Mini Card slot |
| Network Boot | Enables/disables the computer's ability to boot from an operating system installed on a network server. (Feature available on NIC models only; the network controller must be either a PCI Express expansion card or embedded on the system board.) |
| System IDs | Displays: <ul style="list-style-type: none">• Product Name• Serial number• Universal Unique Identifier (UUID) number. The UUID can only be updated if the current chassis serial number is invalid. (These ID numbers are normally set in the factory and are used to uniquely identify the system.)• SKU Number• Family Name• Feature Byte• Build ID• Keyboard locale setting |

Table 3-3 Computer Setup—Security (continued)

| | |
|-------------------------------------------------------------------------------|--------------------------------------------------------------------------------------------------------------------------------------------------------------------------------------------------------------------------------------------------------------------------------------------------------------------------------------------------------------------------------------------------------------------------------------------------------------------------------------------------------------------------------------------------------------------------------------------------------------------------------------------------------------------------------------------------------------------------------------------------------------------------------------------------------------------------------------------------------------------------------------------------------------------------------------------------------------------------------------------------------------------------------------------------------------------------------------------------------------------------------------------------------------------------------------------------------------------------------------------------------------------------------------------------------------------------------------------------------------------------------------------------------------------------------------------------------------------------------------------------------------------------------------------------------------------------------------------------------------------------------------------------------------------------------------------------------------------------------------------------------------------------------------------------------------------------------------------------------------------------------------------------------------------------------------------------------------------------------------------------------------------------------------------------------------------------------------------------------------------------------------------------------------------------------------------------------------------------------------------------------------------------------------------------------------------------------------------------------------------------------------------------------------------------------------------------------------------------------------------------------------------------------------------------------------------------------------------------------------------------------------------------------------------------------------------------------------------------------------------------------------------------------------------------------------------------------------------------------------------------------------------------------------------------------------------------------------------------------------------------------|
| System Security (some models: these options are hardware dependent) | <p>Data Execution Prevention (some models) (enable/disable) - Helps prevent operating system security breaches.</p> <p>PAVP (Models with Blu-ray drives) (disabled/min/max) - PAVP enables the Protected Audio Video Path in the Chipset. This may allow viewing of some protected high definition content that would otherwise be prohibited from playback. Selecting Max will assign 96 Megabytes of system memory exclusively to PAVP.</p> <p>Virtualization Technology (some models) (enable/disable) - Controls the virtualization features of the processor. Changing this setting requires turning the computer off and then back on.</p> <p>Virtualization Technology Directed I/O (some models) (enable/disable) - Controls virtualization DMA remapping features of the chipset. Changing this setting requires turning the computer off and then back on.</p> <p>Trusted Execution Technology (some models) (enable/disable) - Controls the underlying processor and chipset features needed to support a virtual appliance. Changing this setting requires turning the computer off and then back on. To enable this feature you must enable the following features:</p> <ul style="list-style-type: none">• Embedded Security Device Support• Virtualization Technology• Virtualization Technology Directed I/O <p>Embedded Security Device Support (some models) (enable/disable) - Permits activation and deactivation of the Embedded Security Device. Changing this setting requires turning the computer off and then back on.</p> <p>NOTE: To configure the Embedded Security Device, a Setup password must be set.</p> <ul style="list-style-type: none">• Reset to Factory Settings (some models) (Do not reset/Reset) - Resetting to factory defaults will erase all security keys. Changing this setting requires turning the computer off and then back on. <p>CAUTION: The embedded security device is a critical component of many security schemes. Erasing the security keys will prevent access to data protected by the Embedded Security Device. Choosing Reset to Factory Settings may result in significant data loss.</p> <hr/> <p>OS management of Embedded Security Device (some models) (enable/disable) - This option allows the user to limit operating system control of the Embedded Security Device. Changing this setting requires turning the computer off and then back on. This option allows the user to limit OS control of the Embedded Security Device.</p> <ul style="list-style-type: none">• Reset of Embedded Security Device through OS (some models) (enable/disable) - This option allows the user to limit the operating system ability to request a Reset to Factory Settings of the Embedded Security Device. Changing this setting requires turning the computer off and then back on. <p>NOTE: To enable this option, a Setup password must be set.</p> |
|-------------------------------------------------------------------------------|--------------------------------------------------------------------------------------------------------------------------------------------------------------------------------------------------------------------------------------------------------------------------------------------------------------------------------------------------------------------------------------------------------------------------------------------------------------------------------------------------------------------------------------------------------------------------------------------------------------------------------------------------------------------------------------------------------------------------------------------------------------------------------------------------------------------------------------------------------------------------------------------------------------------------------------------------------------------------------------------------------------------------------------------------------------------------------------------------------------------------------------------------------------------------------------------------------------------------------------------------------------------------------------------------------------------------------------------------------------------------------------------------------------------------------------------------------------------------------------------------------------------------------------------------------------------------------------------------------------------------------------------------------------------------------------------------------------------------------------------------------------------------------------------------------------------------------------------------------------------------------------------------------------------------------------------------------------------------------------------------------------------------------------------------------------------------------------------------------------------------------------------------------------------------------------------------------------------------------------------------------------------------------------------------------------------------------------------------------------------------------------------------------------------------------------------------------------------------------------------------------------------------------------------------------------------------------------------------------------------------------------------------------------------------------------------------------------------------------------------------------------------------------------------------------------------------------------------------------------------------------------------------------------------------------------------------------------------------------------------------------|

Computer Setup—Power

 **NOTE:** Support for specific Computer Setup options may vary depending on the hardware configuration.

Table 3-4 Computer Setup—Power

| Option | Description |
|----------------------------------|----------------------------------------------------------------------------------------------------------------------------------------------------------------------------------------------------------------------------------------------------------------------------------------------------------------------------------------------------------------------------------------------------------------------------------------------------------------------------------------------------------------------------------------------------------------------------------------------------------------------------------------------------------------------------------------------------------------------------------------------------------------------------------------------------------------------------------------------------------------------------------------------------------------------------------------------------------------------------------------------------------------------------------------------------------------------------------------------------------------------------------------------------------------------------------------------------------------------------------------------------------------------------------------------------------------------------------|
| Hardware Power Management | <ul style="list-style-type: none">• SATA Power Management—Enables or disables the SATA bus and/or device power management. Default is enabled.• S5 Maximum Power Savings—Turns off power to all nonessential hardware when system is off to meet EUP Lot 6 requirement of less than 1 Watt power usage. Enabling this feature will disable any wake events and management devices while in S5. Default is disabled.• S5 Wake on LAN—Enables or disables remotely waking up the computer from S5 (power is off) power state. Default is disabled. <p>Disabling this feature obtains the lowest power consumption available on the computer during S5. It does not affect the ability of the computer to Wake on LAN from suspend or hibernation, but will prevent it from waking from S5 via the network. It does not affect operation of the network connection while the computer is on.</p> <p>If a network connection is not required, completely disable the network controller (NIC) by using the arrow (left and right) keys to select the Security > Device Security menu. Set the Network Controller option to Device Hidden. This prevents the network controller from being used by the operating system and reduces the power used by the computer in S5.</p> |
| Thermal | Displays the CPU fan speed and system fan speed (RPMs). |

Computer Setup—Advanced



NOTE: Support for specific Computer Setup options may vary depending on the hardware configuration.

Table 3-5 Computer Setup—Advanced

| Option | Heading |
|---------------------------|-------------------------------------------------------------------------------------------------------------------------------------------------------------------------------------------------------------------------------------------------------------------------------------------------------------------------------------------------------------------------------------------------------------------------------------------------------------------------------------------------------------------------------------------------------------------------------------------------------------------------------------------------------------------------------------------------------------------------------------------------------------------------------------------------------------------------------------------------------------------------------------------------------------------------------------------------------------------------------------------------------------------------------------------------------------------------------------------------------------------------------------------------------------------------------------------------------------------------------------------------------------------------------------------------------------------------------------------------------------------|
| Power-On Options | <p>Allows you to set:</p> <ul style="list-style-type: none">• POST messages (enable/disable). Suppresses most POST messages, such as memory count, product name, and other non-error text messages. If a POST error occurs, the error is displayed regardless of the mode selected.• After Power Loss (off/on/previous state): Setting this option to:<ul style="list-style-type: none">◦ Off—causes the computer to remain powered off when power is restored.◦ On—causes the computer to power on automatically as soon as power is restored.◦ Previous state—causes the computer to power on automatically as soon as power is restored, if it was on when power was lost. <p>NOTE: If you turn off power to the computer using the switch on a power strip, you will not be able to use the suspend/sleep feature or the Remote Management features.</p> <ul style="list-style-type: none">• POST Delay (None, 5, 10 15, or 20 seconds). Enabling this feature will add a user-specified delay to the POST process. This delay is sometimes needed for hard disks on some PCI cards that spin up very slowly, so slowly that they are not ready to boot by the time POST is finished. The POST delay also gives you more time to select F10 to enter Computer (F10) Setup. |
| BIOS Power-On | Allows you to set the computer to turn on automatically at a time you specify. |
| Bus Options | <p>On some models, allows you to enable or disable:</p> <ul style="list-style-type: none">• PCI SERR# Generation.• PCI VGA Palette Snooping, which sets the VGA palette snooping bit in PCI configuration space; only needed when more than one graphics controller is installed. |
| Device Options | <p>Allows you to set:</p> <ul style="list-style-type: none">• Num Lock State at Power-On (off/on). Default is on.• Hyper-threading (enable/disable). Default is enabled.• Internal Speaker (some models) (does not affect external speakers). Default is enabled.• NIC PXE Option ROM Download (enable/disable). The BIOS contains an embedded NIC option ROM to allow the unit to boot through the network to a PXE server. This is typically used to download a corporate image to a hard drive. The NIC option ROM takes up memory space below 1MB commonly referred to as DOS Compatibility Hole (DCH) space. This space is limited. This F10 option will allow users to disable the downloading of this embedded NIC option ROM thus giving more DCH space for additional PCI cards which may need option ROM space. The default will be to have the NIC PXE option-ROM-enabled. |
| Management Devices | <p>The Management Devices menu will only be displayed in the Advanced menu when the BIOS detects multiple management options.</p> <p>This option is for installed NIC cards that support ASF or DASH. Use the Management Devices menu to select if the BIOS management operations will be through the embedded solution or one of the installed NIC cards.</p> |

4 Serial ATA (SATA) Drive Guidelines and Features

 **NOTE:** HP only supports the use of SATA hard drives on these models of computer. No Parallel ATA (PATA) drives are supported.

SATA Hard Drives

| Serial ATA Hard Drive Characteristics | |
|-----------------------------------------|-------------------|
| Number of pins/conductors in data cable | 7/7 |
| Number of pins in power cable | 15 |
| Maximum data cable length | 39.37 in (100 cm) |
| Data interface voltage differential | 400-700 mV |
| Drive voltages | 3.3 V, 5 V, 12 V |
| Jumpers for configuring drive | N/A |
| Data transfer rate | 3.0 Gb/s |

SATA Hard Drive Cables

SATA Data Cable

Always use an HP approved SATA 3.0 Gb/s cable as it is fully backwards compatible with the SATA 1.5 Gb/s drives.

Current HP desktop products ship with SATA 3.0 Gb/s hard drives.

SATA data cables are susceptible to damage if overflexed. Never crease a SATA data cable and never bend it tighter than a 30 mm (1.18 in) radius.

The SATA data cable is a thin, 7-pin cable designed to transmit data for only a single drive.

SMART ATA Drives

The Self Monitoring Analysis and Recording Technology (SMART) ATA drives for the HP Personal Computers have built-in drive failure prediction that warns the user or network administrator of an impending failure or crash of the hard drive. The SMART drive tracks fault prediction and failure indication parameters such as reallocated sector count, spin retry count, and calibration retry count. If the drive determines that a failure is imminent, it generates a fault alert.

Hard Drive Capacities

The combination of the file system and the operating system used in the computer determines the maximum usable size of a drive partition. A drive partition is the largest segment of a drive that may be properly accessed by the operating system. A single hard drive may therefore be subdivided into a number of unique drive partitions in order to make use of all of its space.

Because of the differences in the way that drive sizes are calculated, the size reported by the operating system may differ from that marked on the hard drive or listed in the computer specification. Drive size calculations by drive manufacturers are bytes to the base 10 while calculations by Microsoft are bytes to the base 2.

| Drive/Partition Capacity Limits | | | | |
|---------------------------------|-----------------|------------------------|--------------|-------|
| | | | Maximum Size | |
| File System | Controller Type | Operating System | Partition | Drive |
| FAT 32 | ATA | Windows XP/Vista/Win 7 | 32 GB | 2 TB |
| NTFS | ATA | Windows XP/Vista/Win 7 | 2 TB | 2 TB |

5 Identifying the Chassis, Routine Care, and Disassembly Preparation

This chapter provides general service information for the computer. Adherence to the procedures and precautions described in this chapter is essential for proper service.

⚠ CAUTION: When the computer is plugged into an AC power source, voltage is always applied to the system board. You must disconnect the power cord from the power source before opening the computer to prevent system board or component damage.

Chassis Designation

An all-in one form factor is available.

All-in One



Electrostatic Discharge Information

A sudden discharge of static electricity from your finger or other conductor can destroy static-sensitive devices or microcircuitry. Often the spark is neither felt nor heard, but damage occurs. An electronic device exposed to electrostatic discharge (ESD) may not appear to be affected at all and can work perfectly throughout a normal cycle. The device may function normally for a while, but it has been degraded in the internal layers, reducing its life expectancy.

Networks built into many integrated circuits provide some protection, but in many cases, the discharge contains enough power to alter device parameters or melt silicon junctions.

Generating Static

The following table shows that:

- Different activities generate different amounts of static electricity.
- Static electricity increases as humidity decreases.

| Event | Relative Humidity | | |
|----------------------------------|-------------------|----------|----------|
| | 55% | 40% | 10% |
| Walking across carpet | 7,500 V | 15,000 V | 35,000 V |
| Walking across vinyl floor | 3,000 V | 5,000 V | 12,000 V |
| Motions of bench worker | 400 V | 800 V | 6,000 V |
| Removing DIPs* from plastic tube | 400 V | 700 V | 2,000 V |
| Removing DIPs* from vinyl tray | 2,000 V | 4,000 V | 11,500 V |
| Removing DIPs* from Styrofoam | 3,500 V | 5,000 V | 14,500 V |
| Removing bubble pack from PCB | 7,000 V | 20,000 V | 26,500 V |
| Packing PCBs in foam-lined box | 5,000 V | 11,000 V | 21,000 V |

*These are then multi-packaged inside plastic tubes, trays, or Styrofoam.

 **NOTE:** 700 volts can degrade a product.

Preventing Electrostatic Damage to Equipment

Many electronic components are sensitive to ESD. Circuitry design and structure determine the degree of sensitivity. The following packaging and grounding precautions are necessary to prevent damage to electric components and accessories.

- To avoid hand contact, transport products in static-safe containers such as tubes, bags, or boxes.
- Protect all electrostatic parts and assemblies with conductive or approved containers or packaging.
- Keep electrostatic sensitive parts in their containers until they arrive at static-free stations.
- Place items on a grounded surface before removing them from their container.

- Always be properly grounded when touching a sensitive component or assembly.
- Avoid contact with pins, leads, or circuitry.
- Place reusable electrostatic-sensitive parts from assemblies in protective packaging or conductive foam.

Personal Grounding Methods and Equipment

Use the following equipment to prevent static electricity damage to equipment:

- **Wrist straps** are flexible straps with a maximum of one-megohm \pm 10% resistance in the ground cords. To provide proper ground, a strap must be worn snug against bare skin. The ground cord must be connected and fit snugly into the banana plug connector on the grounding mat or workstation.
- **Heel straps/Toe straps/Boot straps** can be used at standing workstations and are compatible with most types of shoes or boots. On conductive floors or dissipative floor mats, use them on both feet with a maximum of one-megohm \pm 10% resistance between the operator and ground.

| Static Shielding Protection Levels | |
|------------------------------------|---------|
| Method | Voltage |
| Antistatic plastic | 1,500 |
| Carbon-loaded plastic | 7,500 |
| Metallized laminate | 15,000 |

Grounding the Work Area

To prevent static damage at the work area, use the following precautions:

- Cover the work surface with approved static-dissipative material. Provide a wrist strap connected to the work surface and properly grounded tools and equipment.
- Use static-dissipative mats, foot straps, or air ionizers to give added protection.
- Handle electrostatic sensitive components, parts, and assemblies by the case or PCB laminate. Handle them only at static-free work areas.
- Turn off power and input signals before inserting and removing connectors or test equipment.
- Use fixtures made of static-safe materials when fixtures must directly contact dissipative surfaces.
- Keep work area free of nonconductive materials such as ordinary plastic assembly aids and Styrofoam.
- Use field service tools, such as cutters, screwdrivers, and vacuums, that are conductive.

Recommended Materials and Equipment

Materials and equipment that are recommended for use in preventing static electricity include:

- Antistatic tape
- Antistatic smocks, aprons, or sleeve protectors

- Conductive bins and other assembly or soldering aids
- Conductive foam
- Conductive tabletop workstations with ground cord of one-megohm +/- 10% resistance
- Static-dissipative table or floor mats with hard tie to ground
- Field service kits
- Static awareness labels
- Wrist straps and footwear straps providing one-megohm +/- 10% resistance
- Material handling packages
- Conductive plastic bags
- Conductive plastic tubes
- Conductive tote boxes
- Opaque shielding bags
- Transparent metallized shielding bags
- Transparent shielding tubes

Operating Guidelines

To prevent overheating and to help prolong the life of the computer:

- Keep the computer away from excessive moisture, direct sunlight, and extremes of heat and cold.
- Operate the computer on a sturdy, level surface. Leave a 10.2-cm (4-inch) clearance on all vented sides of the computer and above the monitor to permit the required airflow.
- Never restrict the airflow into the computer by blocking any vents or air intakes. Do not place the keyboard, with the keyboard feet down, directly against the front of the desktop unit as this also restricts airflow.
- Occasionally clean the air vents on all vented sides of the computer. Lint, dust, and other foreign matter can block the vents and limit the airflow. Be sure to unplug the computer before cleaning the air vents.
- Never operate the computer with the cover removed.
- Do not place computers so near each other that they are subject to each other's re-circulated or preheated air.
- Keep liquids away from the computer and keyboard.
- Never cover the ventilation slots on the monitor with any type of material.
- Install or enable power management functions of the operating system or other software, including sleep states.

Routine Care

General Cleaning Safety Precautions

1. Never use solvents or flammable solutions to clean the computer.
2. Never immerse any parts in water or cleaning solutions; apply any liquids to a clean cloth and then use the cloth on the component.
3. Always unplug the computer when cleaning with liquids or damp cloths.
4. Always unplug the computer before cleaning the keyboard, mouse, or air vents.
5. Disconnect the keyboard before cleaning it.
6. Wear safety glasses equipped with side shields when cleaning the keyboard.

Cleaning the Computer Case

Follow all safety precautions in [General Cleaning Safety Precautions on page 23](#) before cleaning the computer.

To clean the computer case, follow the procedures described below:

- To remove light stains or dirt, use plain water with a clean, lint-free cloth or swab.
- For stronger stains, use a mild dishwashing liquid diluted with water. Rinse well by wiping it with a cloth or swab dampened with clear water.
- For stubborn stains, use isopropyl (rubbing) alcohol. No rinsing is needed as the alcohol will evaporate quickly and not leave a residue.
- After cleaning, always wipe the unit with a clean, lint-free cloth.
- Occasionally clean the air vents on the computer. Lint and other foreign matter can block the vents and limit the airflow.

Cleaning the Keyboard

Follow all safety precautions in [General Cleaning Safety Precautions on page 23](#) before cleaning the keyboard.

To clean the tops of the keys or the keyboard body, follow the procedures described in [Cleaning the Computer Case on page 23](#).

When cleaning debris from under the keys, review all rules in [General Cleaning Safety Precautions on page 23](#) before following these procedures:

 **CAUTION:** Use safety glasses equipped with side shields before attempting to clean debris from under the keys.

- Visible debris underneath or between the keys may be removed by vacuuming or shaking.
- Canned, pressurized air may be used to clean debris from under the keys. Caution should be used as too much air pressure can dislodge lubricants applied under the wide keys.

- If you remove a key, use a specially designed key puller to prevent damage to the keys. This tool is available through many electronic supply outlets.

⚠ CAUTION: Never remove a wide leveled key (like the space bar) from the keyboard. If these keys are improperly removed or installed, the keyboard may not function properly.

- Cleaning under a key may be done with a swab moistened with isopropyl alcohol and squeezed out. Be careful not to wipe away lubricants necessary for proper key functions. Use tweezers to remove any fibers or dirt in confined areas. Allow the parts to air dry before reassembly.

Cleaning the Monitor

- Wipe the monitor screen with a clean cloth moistened with water or with a towelette designed for cleaning monitors. Do not use sprays or aerosols directly on the screen; the liquid may seep into the housing and damage a component. Never use solvents or flammable liquids on the monitor.
- To clean the monitor body follow the procedures in [Cleaning the Computer Case on page 23](#).

Cleaning the Mouse

Before cleaning the mouse, ensure that the power to the computer is turned off.

- Clean the mouse ball by first removing the retaining plate and the ball from the housing. Pull out any debris from the ball socket and wipe the ball with a clean, dry cloth before reassembly.
- To clean the mouse body, follow the procedures in [Cleaning the Computer Case on page 23](#).

Service Considerations

Listed below are some of the considerations that you should keep in mind during the disassembly and assembly of the computer.

Tools and Software Requirements

To service the computer, you need the following:

- Torx T-15 screwdriver (HP screwdriver with bits, PN 161946-001)
- Flat-bladed screwdriver (may sometimes be used in place of the Torx screwdriver)
- Phillips #2 screwdriver
- Diagnostics software
- HP tamper-resistant T-15 wrench (Smart Cover FailSafe Key, PN 166527-001) or HP tamper-resistant bits (Smart Cover FailSafe Key, PN 166527-002)

Screws

The screws used in the computer are not interchangeable. They may have standard or metric threads and may be of different lengths. If an incorrect screw is used during the reassembly process, it can damage the unit. HP strongly recommends that all screws removed during disassembly be kept with the part that was removed, then returned to their proper locations.

⚠ CAUTION: As each subassembly is removed from the computer, it should be placed away from the work area to prevent damage.

Cables and Connectors

Most cables used throughout the unit are flat, flexible cables. These cables must be handled with care to avoid damage. Apply only the tension required to seat or unseat the cables during insertion or removal from the connector. Handle cables by the connector whenever possible. In all cases, avoid bending or twisting the cables, and ensure that the cables are routed in such a way that they cannot be caught or snagged by parts being removed or replaced.

 **CAUTION:** When servicing this computer, ensure that cables are placed in their proper location during the reassembly process. Improper cable placement can damage the computer.

Hard Drives

Handle hard drives as delicate, precision components, avoiding all physical shock and vibration. This applies to failed drives as well as replacement spares.

- If a drive must be mailed, place the drive in a bubble-pack mailer or other suitable protective packaging and label the package “Fragile: Handle With Care.”
- Do not remove hard drives from the shipping package for storage. Keep hard drives in their protective packaging until they are actually mounted in the CPU.
- Avoid dropping drives from any height onto any surface.
- If you are inserting or removing a hard drive, turn off the computer. Do not remove a hard drive while the computer is on or in standby mode.
- Before handling a drive, ensure that you are discharged of static electricity. While handling a drive, avoid touching the connector. For more information about preventing electrostatic damage, refer to [Electrostatic Discharge Information on page 20](#)
- Do not use excessive force when inserting a drive.
- Avoid exposing a hard drive to liquids, temperature extremes, or products that have magnetic fields such as monitors or speakers.

Lithium Coin Cell Battery

The battery that comes with the computer provides power to the real-time clock and has a minimum lifetime of about three years.

See the appropriate removal and replacement chapter for the chassis you are working on in this guide for instructions on the replacement procedures.

 **WARNING!** This computer contains a lithium battery. There is a risk of fire and chemical burn if the battery is handled improperly. Do not disassemble, crush, puncture, short external contacts, dispose in water or fire, or expose it to temperatures higher than 140°F (60°C). Do not attempt to recharge the battery.

 **NOTE:** Batteries, battery packs, and accumulators should not be disposed of together with the general household waste. In order to forward them to recycling or proper disposal, please use the public collection system or return them to HP, their authorized partners, or their agents.

6 Illustrated parts catalog

Computer major components

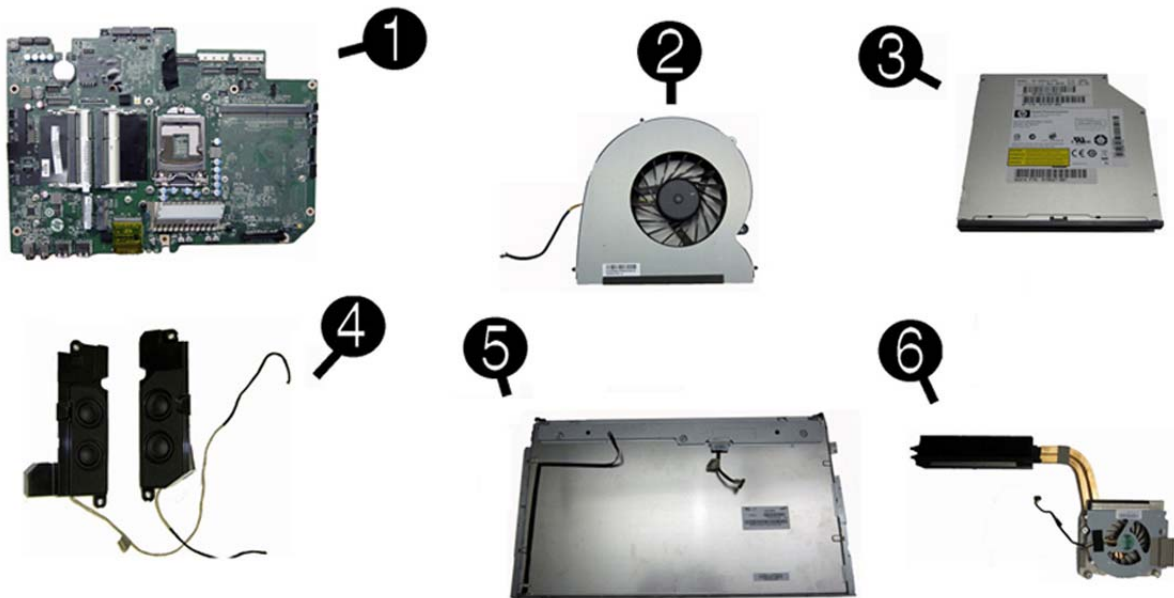

| Item | Description | Spare part number |
|------|-----------------------------------------------------------------------------------|-------------------|
| (1) | System board | 658978-001 |
| (2) | Fan | 652321-001 |
| (3) | Optical drive (does not include bezel) | |
| | HP SuperMulti DVD Writer Drive | 583092-001 |
| | HP Slim Slot Blu-ray Combo Drive | 583093-001 |
| (4) | Speakers | |
| | Right speaker | 652274-001 |
| | Left speaker | 652275-001 |
| (5) | Display panel, 23-inch | |
| | ZBD | 658981-001 |
| | non-ZBD | 658979-001 |
| (6) | Fan sink assembly (thermal module) (includes replacement thermal material) | |

| Item | Description | Spare part number |
|------|---------------------------------------------------------------------------|-------------------|
| | Discrete graphics | 658987-001 |
| | UMA graphics | 658988-001 |
| | Memory modules (PC3-10600, 1333-MHz; not illustrated) | |
| | 4-GB | 646801-001 |
| | 2-GB | 646800-001 |
| | Processor (includes replacement thermal material; not illustrated) | |
| | Intel Core i7 processors | |
| | 2600 (3.4-GHz, 8-MB L3 cache) | 638632-001 |
| | Intel Core i5 processors | |
| | 2500 (3.3-GHz, 6-MB L3 cache) | 638631-001 |
| | 2400 (3.1-GHz, 6-MB L3 cache) | 638630-001 |
| | 2300 (2.8-GHz, 6-MB L3 cache) | 654601-001 |
| | Intel Core i3 processors | |
| | 2120 (3.3-GHz, 3-MB L3 cache) | 638629-001 |
| | 2100 (3.1-GHz, 3-MB L3 cache) | 638628-001 |
| | Intel Pentium Dual-Core processors | |
| | G850 (2.9-GHz, 3-MB L3 cache) | 655973-001 |
| | G840 (2.8-GHz, 3-MB L3 cache) | 655972-001 |
| | G620 (2.6-GHz, 3-MB L3 cache) | 655971-001 |
| | Hard drive (not illustrated) | |
| | 1000-GB | 636930-001 |
| | 750-GB | 639363-001 |
| | 500-GB | 636929-001 |
| | 320-GB | 634824-001 |
| | 250-GB | 636927-001 |
| | 160-GB solid-state drive | 646809-001 |
| | 80-GB solid-state drive | 607817-001 |
| | AC adapter (external; not illustrated) | |
| | 230-W | 654600-001 |
| | 180 W | 654599-001 |
| | 150 W | 651587-001 |
| | Caps (not illustrated) | |
| | Left side cap, no optical drive | 658989-001 |
| | Left side cap, 1394 | 670181-001 |

| Item | Description | Spare part number |
|------|-------------------------------------------------------|-------------------|
| | Right side cap | 670182-001 |
| | Keyboard (not illustrated) | |
| | USB | |
| | • Brazil | 590271-201 |
| | • French Canada | 590271-121 |
| | • Latin America | 590271-161 |
| | • The United States | 590271-001 |
| | USB Enterprise | |
| | • Brazil | 658990-201 |
| | • French Canada | 658990-121 |
| | • Latin America | 658990-161 |
| | • The United States | 658990-001 |
| | Wireless for use in the United States | 611376-003 |
| | USB Smartcard | |
| | • Brazil | 631411-204 |
| | • French Canada | 631411-124 |
| | • The United States | 631411-004 |
| | Washable | |
| | • United States | 613125-001 |
| | • French Canada | 613125-121 |
| | USB, mini | |
| | • United States | 611375-003 |
| | • French Canada | 611375-123 |
| | USB hub keyboard | |
| | • United States | 631913-001 |
| | Mouse (not illustrated) | |
| | USB laser | 609251-001 |
| | USB, optical, Portia | 621416-001 |
| | Washable | 619580-001 |
| | Remote controls (not illustrated) | |
| | For use in North America (English) | 642086-001 |
| | For use in the Asia/Pacific and Latin America regions | 642181-001 |

Boards

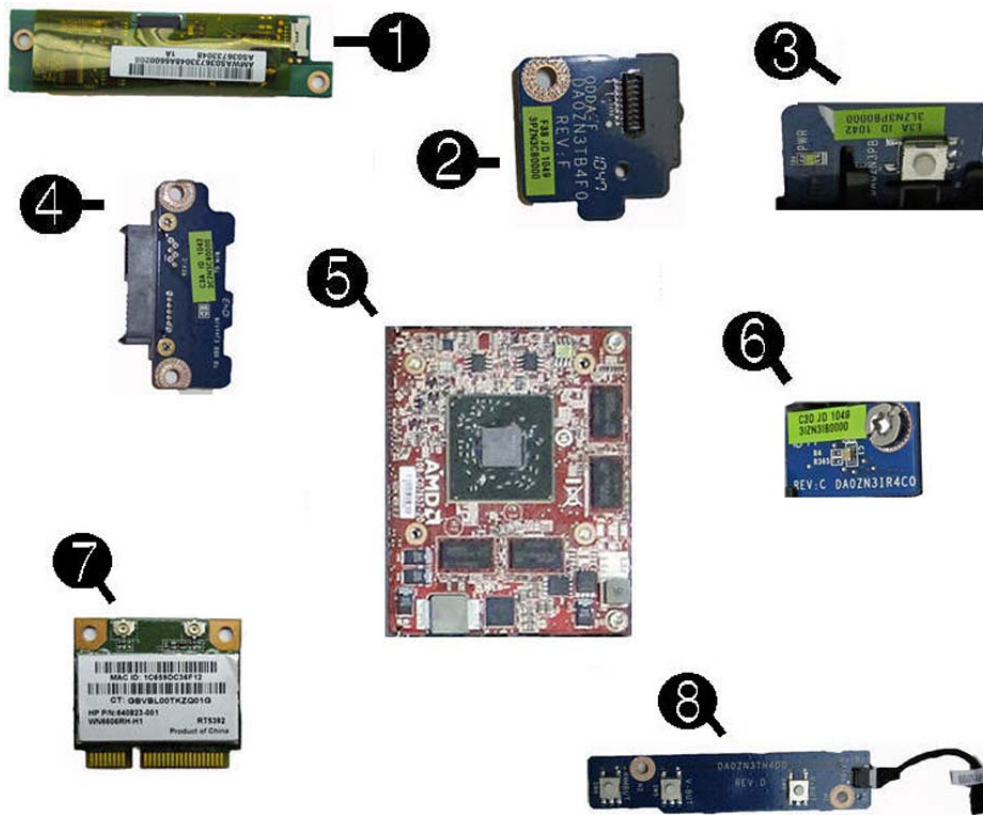

| Item | Description | Spare part number |
|------|------------------------------------------------|-------------------|
| (1) | Inverter | 658982-001 |
| (2) | Optical drive eject board | 652312-001 |
| (3) | Power board | 652305-001 |
| (4) | Optical drive connector board | 652311-001 |
| (5) | Graphics card | |
| | GFX, 1 GB graphics card | 652164-001 |
| | ATI MXM30 Viper 1-GB HD5570 graphics card | 628380-001 |
| (6) | Infrared sensor board | 652307-001 |
| (7) | WLAN modules | |
| | Intel Centrino® Advanced-N 6205 802.11a/b/g/n | 652165-001 |
| | 802.11b/g/n | 654602-001 |
| | HP WLAN combo 802.11b/g/n + Bluetooth 2.1 card | 652279-001 |
| (8) | Volume button board | 652306-001 |
| | G-sensor board (not illustrated) | 658983-001 |
| | TV tuner module (not illustrated) | 613990-001 |

| Item | Description | Spare part number |
|------|------------------------------------------------------------|-------------------|
| | I/O board assembly, with DataPort (not illustrated) | |
| | Includes IR | 670183-001 |
| | Does not include IR | 670184-001 |
| | Webcam (not illustrated) | |
| | Webcam module without DMIC | 652277-001 |
| | Webcam module, 2.0 MP, FHD | 658985-001 |
| | Webcam lens cover | 654598-001 |
| | Webcam wheel cap | 658986-001 |

Cables

| Description | Spare part number |
|-------------------------------------------------------|-------------------|
| IR blaster cable | 652276-001 |
| Optical drive transfer cable , 275 mm | 652286-001 |
| Optical drive eject cable , 190 mm | 652299-001 |
| Sensor2 cable , 100 mm | 654301-001 |
| FFC I/O cable , 449 mm | 658980-001 |
| G-sensor cable | 658984-001 |
| Cable, DisplayPort to HDMI (not illustrated) | 617450-001 |
| NTSC cable | 670180-001 |
| UMA (Integrated graphics) I/O-DataPort cable | 670185-001 |
| MXM (Discrete graphics) I/O-System board cable | 670186-001 |

Sequential part number listing

| Spare part number | Description |
|-------------------|-------------------------------------------|
| 583092-001 | HP SuperMulti DVD Writer Drive |
| 583093-001 | HP Slim Slot Blu-ray Combo Drive |
| 590271-001 | USB keyboard for use in the United States |
| 590271-121 | USB keyboard for use in French Canada |
| 590271-161 | USB keyboard for use in Latin America |
| 590271-201 | USB keyboard for use in Brazil |
| 607817-001 | 80-GB solid-state drive |
| 609251-001 | Mouse, USB, laser |

| Spare part number | Description |
|--------------------------|----------------------------------------------------------------------|
| 611375-003 | Keyboard, USB, mini, for use in the United States |
| 611375-123 | Keyboard, USB, mini, for use in French Canada |
| 613125-001 | Keyboard, washable, for use in the United States |
| 613125-121 | Keyboard, washable, for use in French Canada |
| 613990-001 | HP TV tuner module |
| 617450-001 | Cable, DisplayPort to HDMI |
| 619580-001 | Mouse, washable |
| 621416-001 | Mouse, USB, optical, Portia |
| 628380-001 | ATI MXM30 Viper 1-GB HD5570 graphics card |
| 631411-004 | Keyboard, USB, Smartcard, for use in the United States |
| 631411-124 | Keyboard, USB, Smartcard, for use in French Canada |
| 631411-204 | Keyboard, USB, Smartcard, for use in Brazil |
| 631913-001 | Keyboard, USB hub |
| 634824-001 | Hard drive, 320 GB |
| 636927-001 | Hard drive, 250 GB |
| 636929-001 | Hard drive, 500 GB |
| 636930-001 | Hard drive, 1000 GB |
| 638628-001 | Intel Core i3, 2100 processor (3.1-GHz, 3-MB L3 cache) |
| 638629-001 | Intel Core i3, 2120 processor (3.3-GHz, 3-MB L3 cache) |
| 638630-001 | Intel Core i5, 2400 processor (3.1-GHz, 6-MB L3 cache) |
| 638631-001 | Intel Core i5, 2500 processor (3.3-GHz, 6-MB L3 cache) |
| 638632-001 | Intel Core i7, 2600 processor (3.4-GHz, 8-MB L3 cache) |
| 639363-001 | Hard drive, 750 GB |
| 642086-001 | Remote control for use in North America |
| 642181-001 | Remote control for use in the Asia/Pacific and Latin America regions |
| 646800-001 | 2-GB memory module (PC3-10600, 1333-MHz) |
| 646801-001 | 4-GB memory module (PC3-10600, 1333-MHz) |
| 646809-001 | 160-GB Solid-state drive |
| 651587-001 | AC adapter, 150W (external) |
| 652164-001 | GFX, 1 GB graphics card |
| 652165-001 | Intel Centrino® Advanced-N 6205 802.11a/b/g/n WLAN card |
| 652274-001 | Speaker, right |
| 652275-001 | Speaker, left |
| 652276-001 | IR blaster cable |

| Spare part number | Description |
|--------------------------|-------------------------------------------------------------------------------------------------------------------------|
| 652277-001 | Webcam module without DMIC |
| 652279-001 | HP WLAN combo 802.11b/g/n + Bluetooth 2.1 card |
| 652286-001 | Optical drive transfer cable, 275 mm |
| 652299-001 | Optical drive eject cable, 190 mm |
| 652305-001 | Power board |
| 652306-001 | Volume button board |
| 652307-001 | Infrared sensor board |
| 652311-001 | Optical drive connector board |
| 652312-001 | Optical drive eject board |
| 652321-001 | Fan |
| 654301-001 | Sensor2 cable, 100 mm |
| 654598-001 | Webcam lens cover |
| 654599-001 | AC adapter, 180W (external) |
| 654600-001 | 230-W AC adapter |
| 654601-001 | Intel Core i5, 2300 processor (2.8-GHz, 6-MB L3 cache) |
| 654602-001 | 802.11b/g/n WLAN card |
| 655971-001 | Intel Pentium Dual-Core, G620 processor (2.6-GHz, 3-MB L3 cache) |
| 655972-001 | Intel Pentium Dual-Core, G840 processor (2.8-GHz, 3-MB L3 cache) |
| 655973-001 | Intel Pentium Dual-Core, G850 processor (2.9-GHz, 3-MB L3 cache) |
| 658978-001 | System board |
| 658979-001 | Display panel, 23-inch, non-ZBD |
| 658980-001 | FFC I/O cable, 449 mm |
| 658981-001 | Display panel, 23-inch, ZBD |
| 658982-001 | Inverter |
| 658983-001 | G-sensor board |
| 658984-001 | G-sensor cable |
| 658985-001 | Webcam module, 2.0 MP, FHD |
| 658986-001 | Webcam wheel cap |
| 658987-001 | Heat sink (thermal module) assembly for use in computers with discrete graphics (includes replacement thermal material) |
| 658988-001 | Heat sink (thermal module) assembly for use in computers with UMA graphics (includes replacement thermal material) |
| 658989-001 | Left side cap, no optical drive |
| 658990-001 | Keyboard, USB Enterprise, for use in the United States |

| Spare part number | Description |
|--------------------------|----------------------------------------------------|
| 658990-121 | Keyboard, USB Enterprise, for use in French Canada |
| 658990-161 | Keyboard, USB Enterprise, for use in Latin America |
| 658990-201 | Keyboard, USB Enterprise, for use in Brazil |
| 670180-001 | NTSC cable |
| 670181-001 | Left side cap for use in models with 1394 ports |
| 670182-001 | Right side cap |
| 670183-001 | I/O board assembly with DataPort and IR |
| 670184-001 | I/O board assembly with DataPort, no IR |
| 670185-001 | UMA (Integrated graphics) I/O-DataPort cable |
| 670186-001 | MXM (Discrete graphics) I/O-System board cable |

7 Removal and Replacement Procedures

The following sections provide information about disassembling various components of the All-in-One.

Preparing to disassemble the computer

To avoid injury and equipment damage, always complete the following steps in order, when opening the All-in-One.

1. Remove all removable media, such as compact discs or USB flash drives, from the computer.
2. Turn off the computer properly through the operating system, then turn off any external devices.
3. Disconnect the power cord from the power outlet and disconnect any external devices.

 **CAUTION:** Regardless of the power-on state, voltage is always present on the system board as long as the system is plugged into an active AC outlet. You must disconnect the power cord to avoid damage to the internal components of the computer.

4. Disconnect all cables from the ports.
5. Place the computer face down on a soft flat surface. HP recommends that you set down a blanket, towel, or other soft cloth to protect the screen surface from scratches or other damage.

 **CAUTION:** Static electricity can damage the electronic components of the computer. Before beginning these procedures, ensure that you are discharged of static electricity by briefly touching a grounded metal object.

 **WARNING!** Beware of sharp edges inside the chassis.

Stand

The stand is secured with four screws. The screws are covered by the plastic piece covering the back of the stand.

To remove the stand:

1. Prepare the computer for disassembly (see [Preparing to disassemble the computer on page 34](#)).
2. Insert your finger, or a flathead screwdriver, into the slot on the stand cover (1) to pry it off of the computer stand.

Figure 7-1 Removing the stand cover

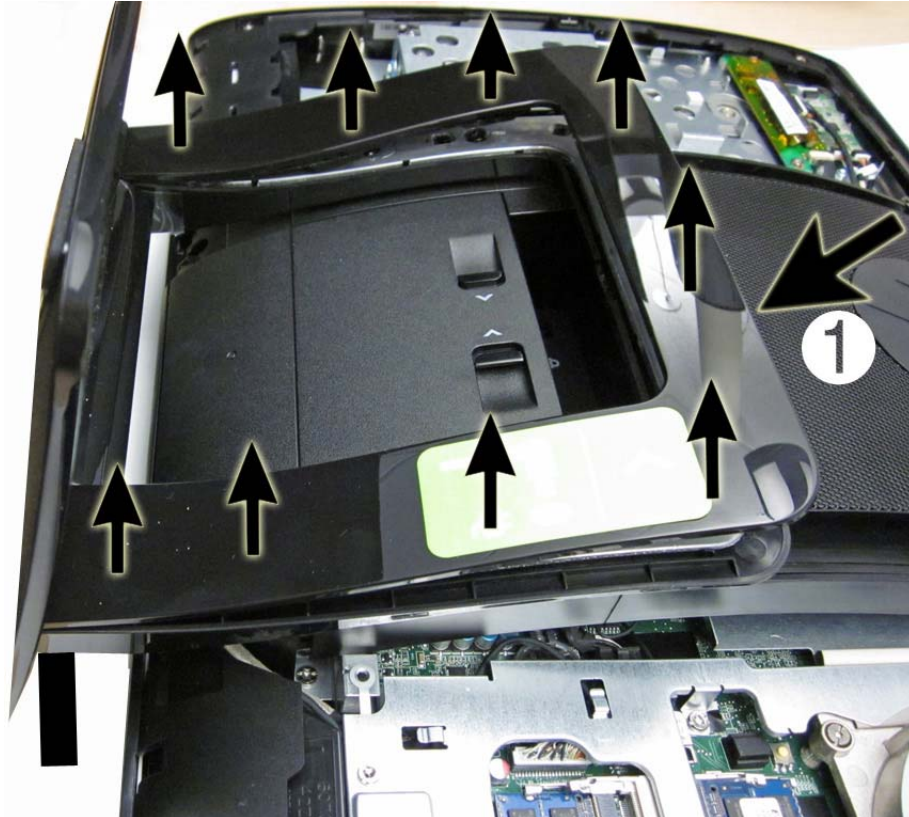

3. Remove the four Torx screws (1), slide the stand toward the top of the computer, and then lift the stand off the computer (2).

 **NOTE:** You can use a Torx or a flat-head driver to remove the screws.

Figure 7-2 Removing the stand



To replace the stand, reverse the removal procedures.

Weight (with integrated graphics) without stand: 8.75 kg (19.3 lbs)

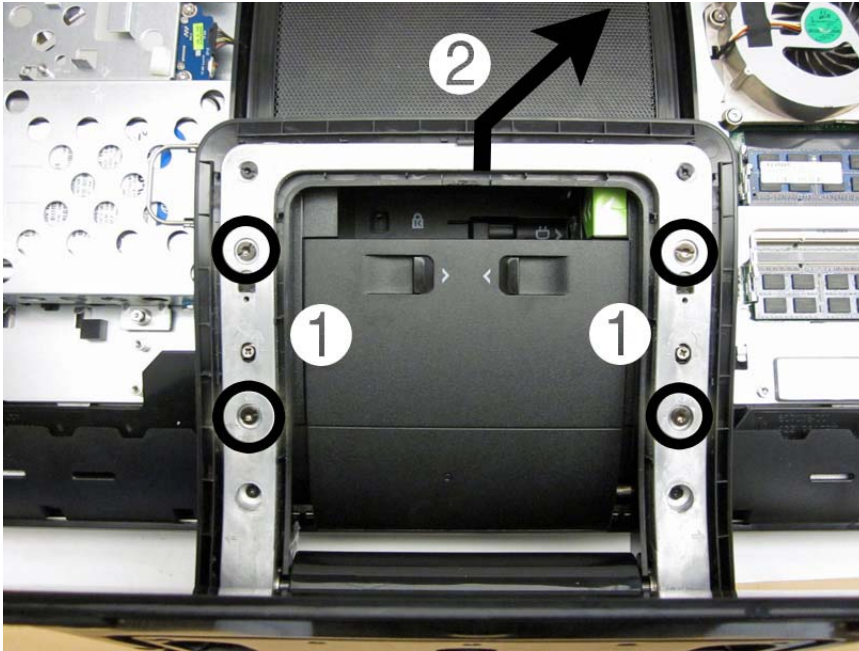
Weight (with discrete graphics) without stand: 9.05 kg (20.0 lbs)

VESA mount

The VESA adapter plate is stored in the bottom of the stand and is mounted in place of the stand.

To install the VESA adapter plate:

1. Prepare the computer for disassembly (see [Preparing to disassemble the computer on page 34](#)).
2. Insert your finger, or a flathead screwdriver, into the slot on the stand cover (1) to pry it off of the computer stand.

Figure 7-3 Removing the stand cover

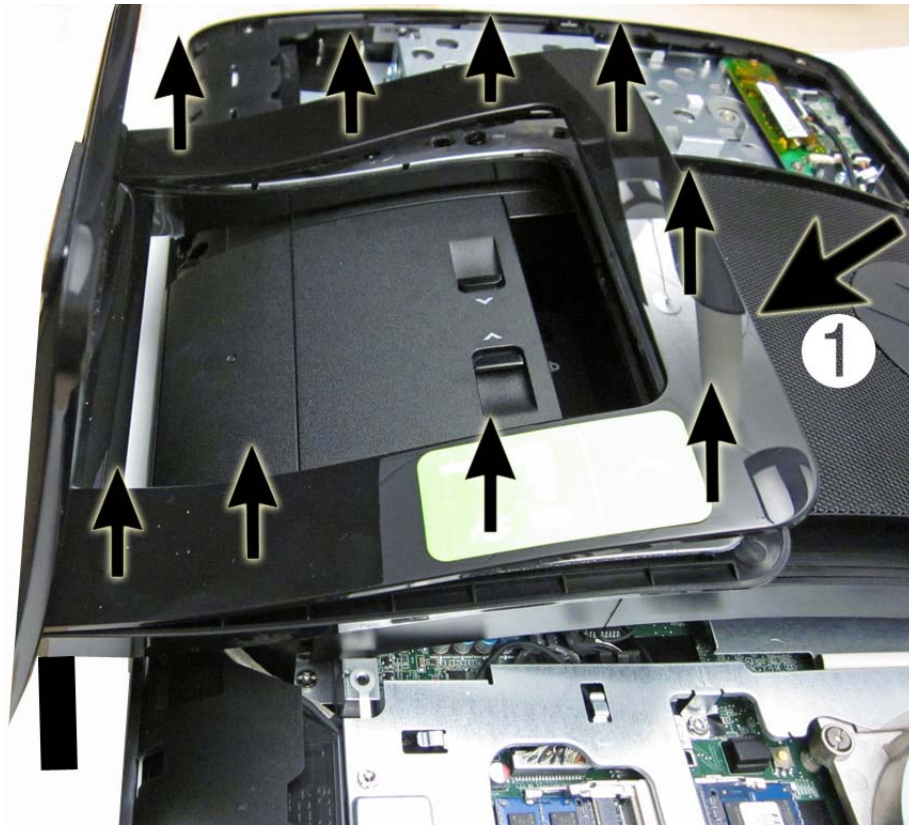

3. Use a Phillips screwdriver to tighten the recessed two brake screws (for the rails) on the computer. It should take about 5–10 turns of the screwdriver to secure the screws. Take care not to overtighten the screws.

 **NOTE:** The tightened brake screws will hold the VESA adapter plate in the locked position, so that the computer does not slide down once it is mounted on a wall. These screws must be tightened before placing the VESA adapter plate on the back of the computer.

Figure 7-4 Tightening the brake screws



4. While the stand is still on the computer, use a Phillips screwdriver to remove the four screws attaching the VESA adapter plate to the bottom of the computer stand. Save the screws.

Figure 7-5 Removing the VESA adapter screws

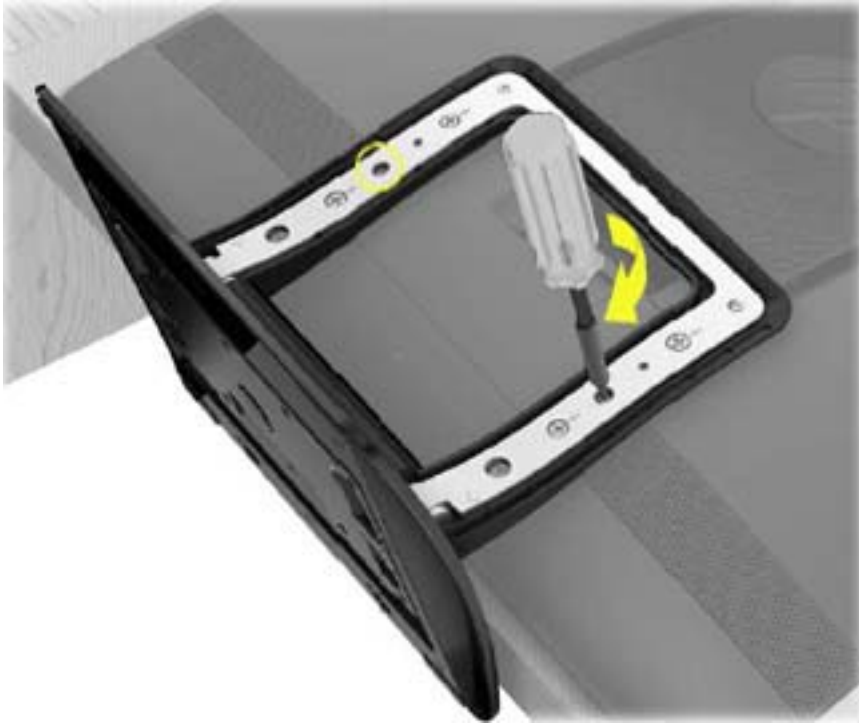
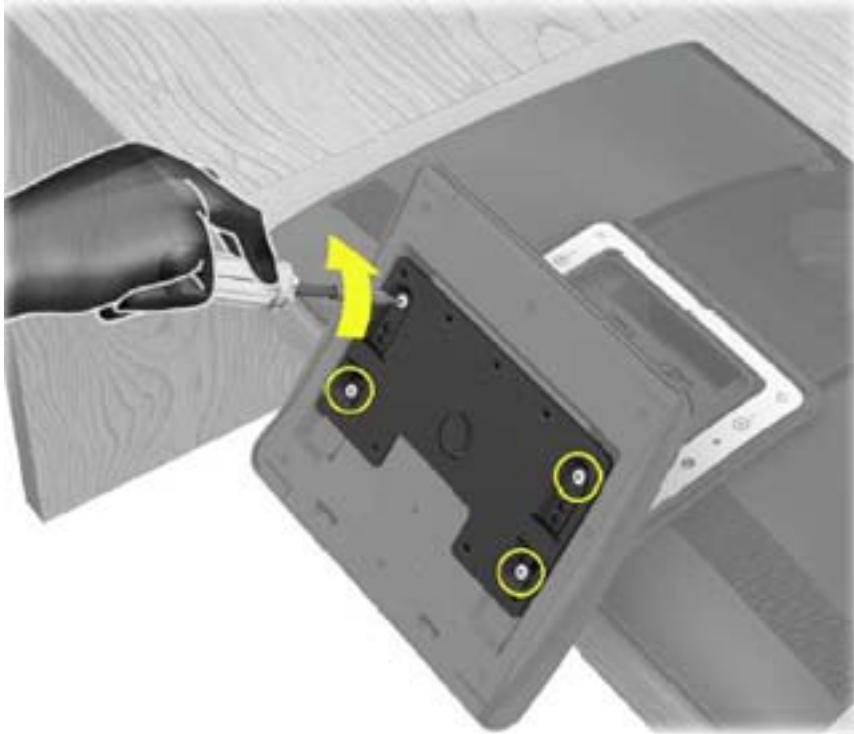

5. Remove the VESA adapter plate from the bottom of the computer stand.

Figure 7-6 Removing the VESA adapter plate



6. Use a flathead screwdriver to remove the four screws attaching the computer stand to the back of the computer.

Figure 7-7 Removing the stand screws

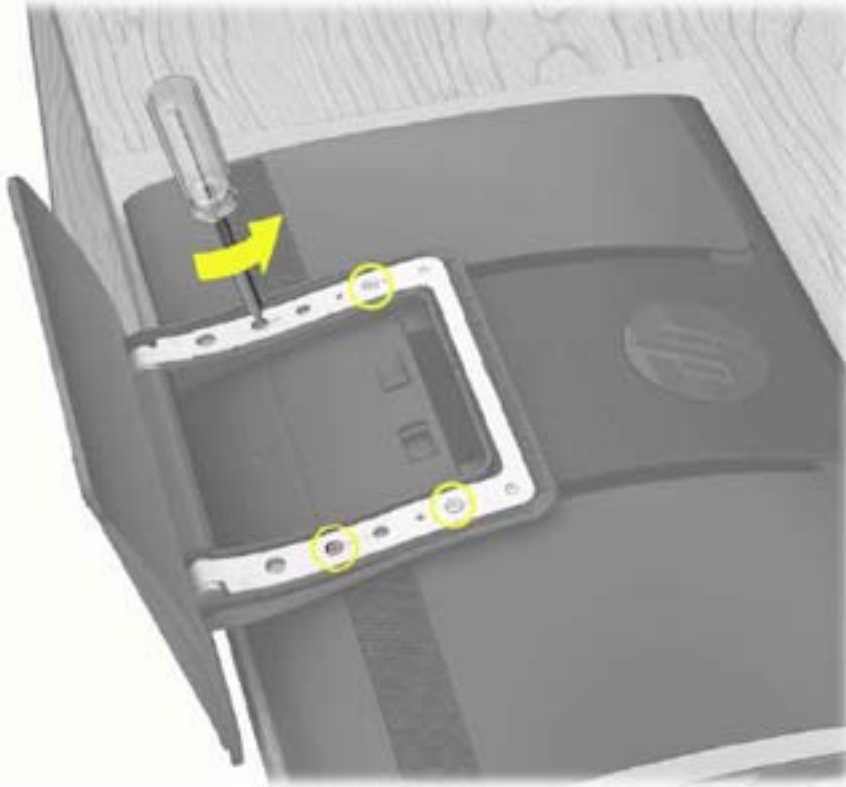

7. Lift the computer stand away from the computer.

Figure 7-8 Removing the stand

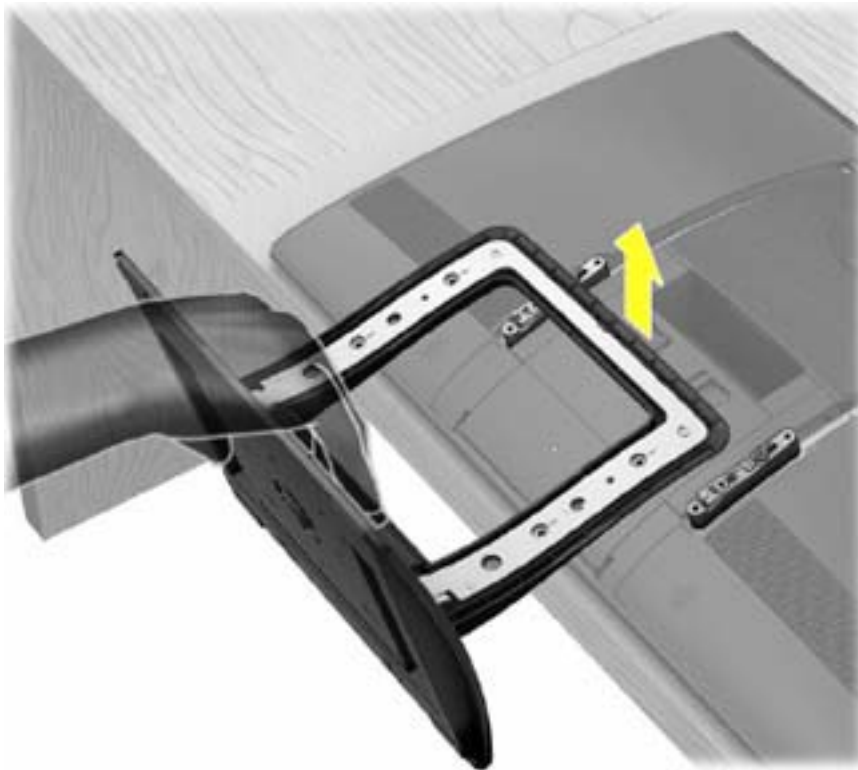

8. Place the VESA adapter plate over the rails on the back of the computer, matching the cutouts on the each side of the plate with the screw holes and the hooks on the rails.

Figure 7-9 Placing the VESA adapter plate on the computer

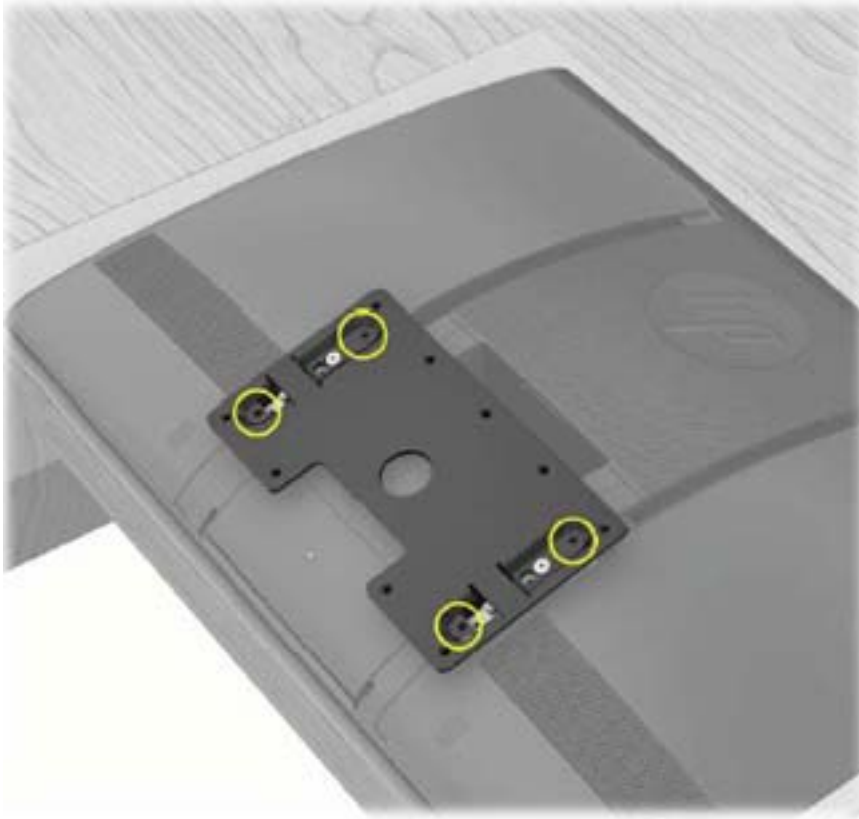

9. Attach the VESA adapter plate to the back of the computer, using a Phillips screwdriver to tighten the four screws.

Figure 7-10 Securing the VESA adapter plate

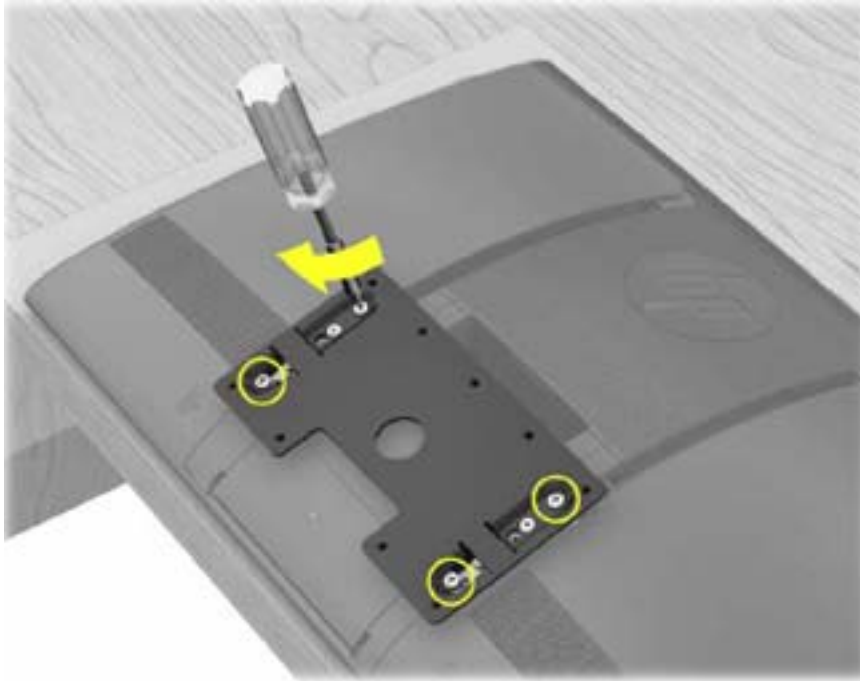

10. Slide the VESA adapter plate upward until it locks into place. You will hear a click when the VESA adapter plate is locked in place.

 **NOTE:** If you do not hear the click or the plate does not lock in place, it means the two brake screws were not sufficiently tightened when the computer stand was removed. Unscrew the four screws on the VESA adapter plate and remove it, then retighten the two brake screws (see step 4 in previous section). Replace the VESA adapter plate by installing and tightening the four screws, then slide the plate up until it locks in place.

Figure 7-11 Locking the VESA adapter plate in place



11. Attach the wall-mounting hardware (purchased separately) to the VESA adapter plate, according to the manufacturer's instructions, using either the 100 mm x 100 mm screw holes or the 100 mm x 200 mm screw holes.

Figure 7-12 100 mm x 100 mm holes

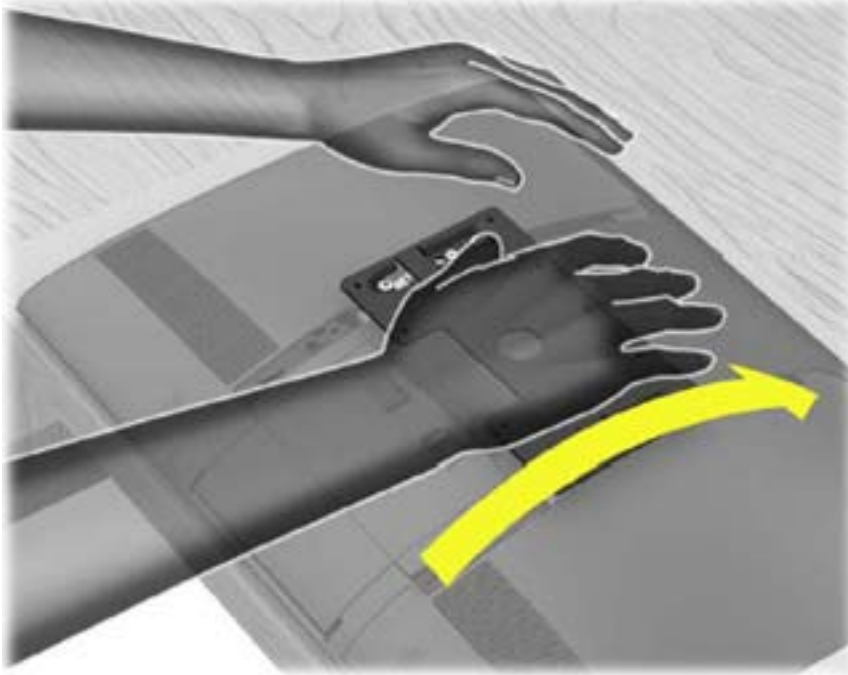
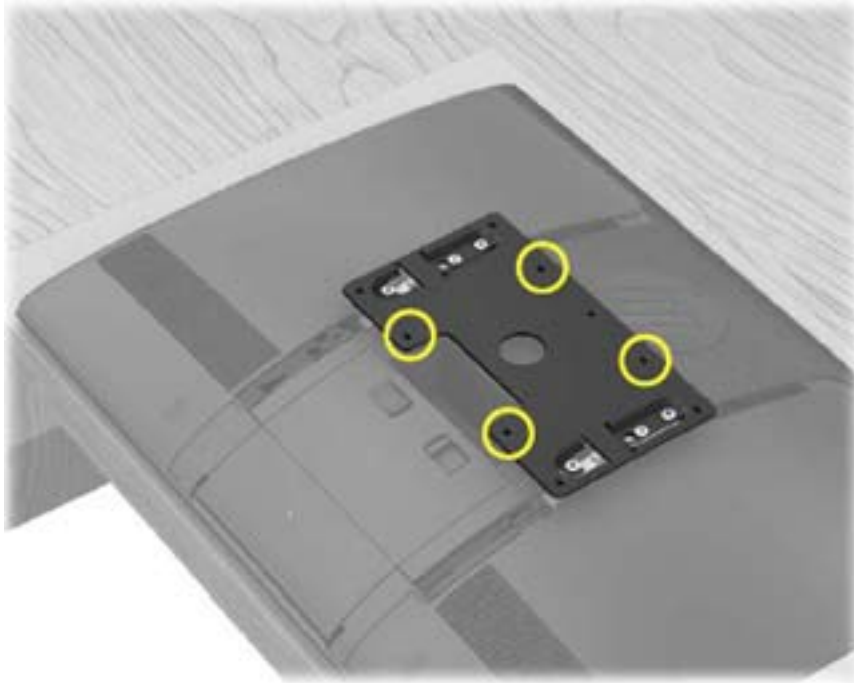
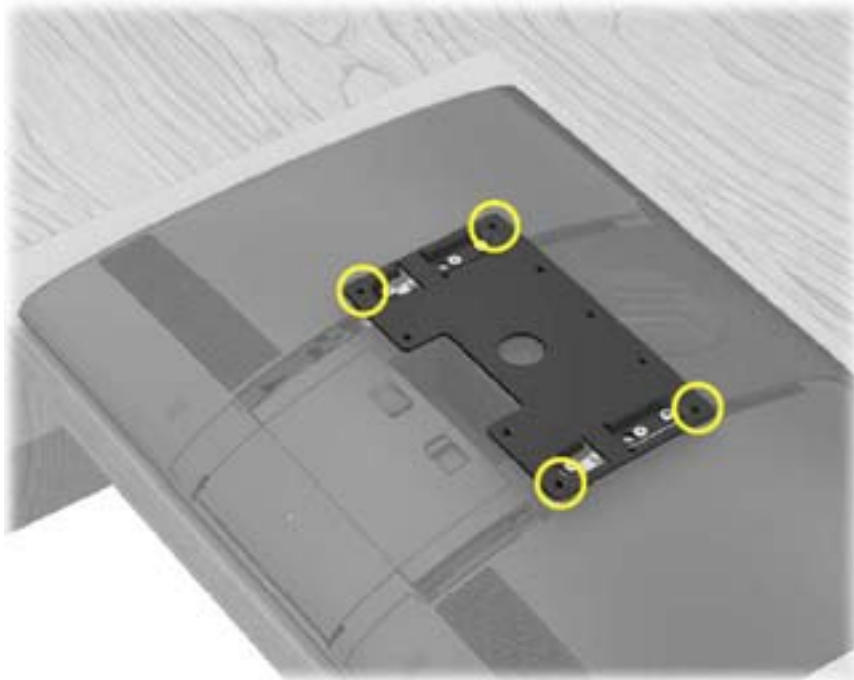



Figure 7-13 100 mm x 200 mm holes



 **NOTE:** The computer can be mounted in either landscape or portrait orientation. If mounted in portrait orientation make sure the CD/DVD drive is at the top. For landscape orientation, keep the same orientation as when the computer is on the stand.

 **NOTE:** If the computer stand is ever replaced on the computer, the VESA adapter plate must be replaced on the bottom of the computer stand in order to properly support the computer.

Note the following information about the computer without the stand but with the VESA adapter installed.

The measurements in the illustration are in mm.

Figure 7-14 Computer dimensions without stand

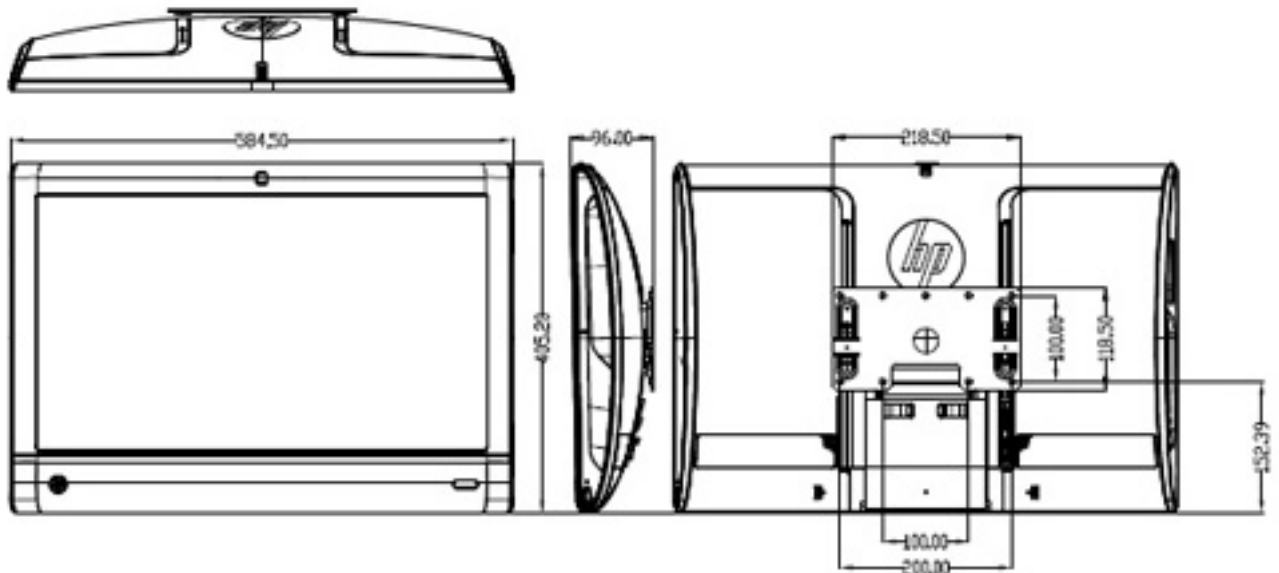

Weight (with integrated graphics) without stand: 8.75 kg (19.3 lbs)

Weight (with discrete graphics) without stand: 9.05 kg (20.0 lbs)

Rear panels

The rear panels are located above the stand. You must remove them to access internal components. Although the following procedure shows only removing one panel, the procedure is the same for both panels.

To remove the rear panels:

1. Prepare the computer for disassembly (see [Preparing to disassemble the computer on page 34](#)).
2. Remove the small center panel below the rear ports by pulling out the top of the panel **(1)** then lifting the panel off the computer **(2)**.

Figure 7-15 Removing the center panel

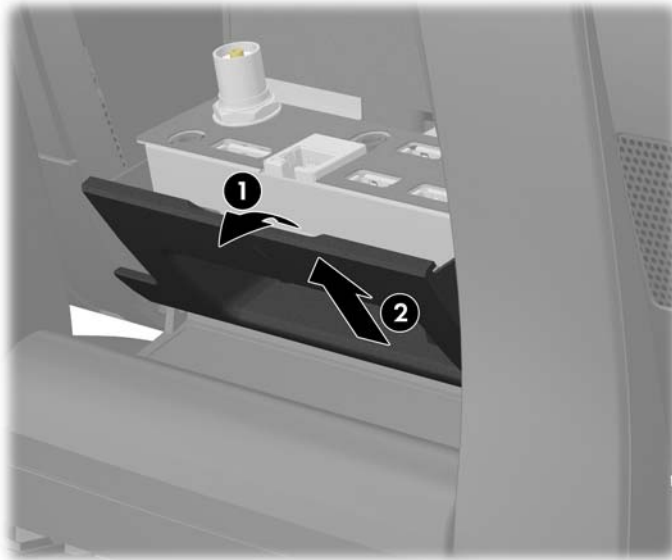

3. Before removing the rear panel, you must remove the small cover plate that hides the screw used to secure the panel to the chassis. Lift up on the bottom of the cover plate located next to the upper inside corner of the rear panel and lift the cover plate off the rear of the computer.

Figure 7-16 Removing the rear panel screw cover plate

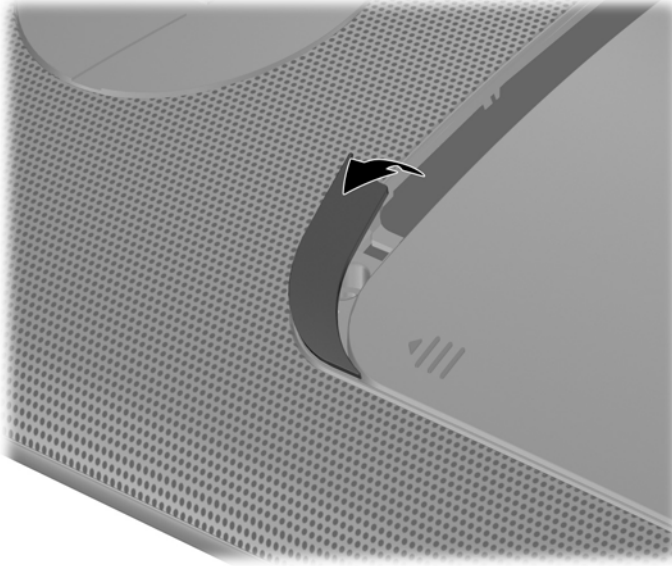

4. Remove the screw beneath the cover plate (1) and slide the rear panel toward the center of the computer until it stops (approximately 5 mm or 1/5 inch) (2). Use the raised grip areas on the top and bottom inside corners of the panel to slide it toward the center of the computer.

Figure 7-17 Releasing the rear panel

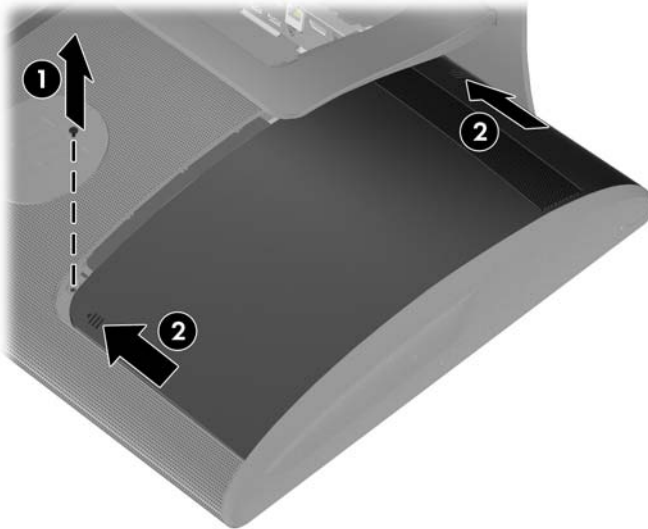

5. Lift up the outside edge of the panel approximately 2.5 cm (1 inch) **(1)** and slide the panel toward the outside edge of the computer **(2)** to remove it.

Figure 7-18 Removing the rear panel

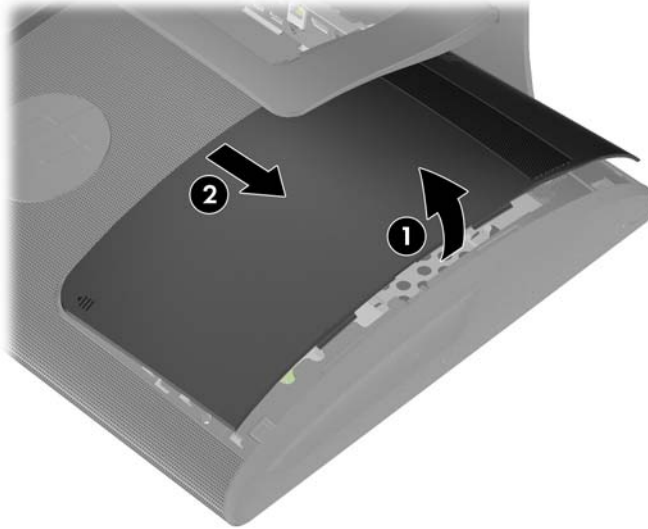

To replace the rear panels, reverse the removal procedures.

 **NOTE:** When replacing a drive access panel, hold the panel at a slight angle with the inside edge of the panel lower than the outside edge, then slide the screw hole tab on the top inside corner of the panel into the slot on the rear of the computer.

Figure 7-19 Replacing the drive access panel



Installing memory

| Description | Spare part number |
|-------------|-------------------|
| 4-GB | 646801-001 |
| 2-GB | 646800-001 |

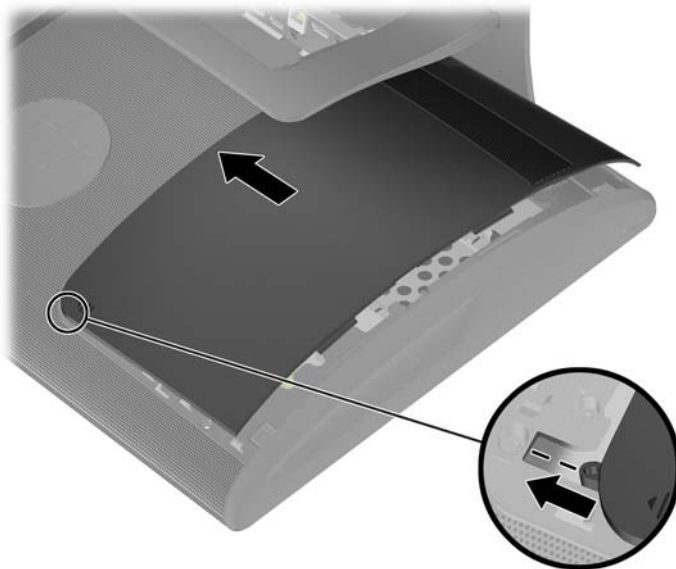
The memory modules are located under the rear cover on the right side of the computer (when viewed from behind).

Figure 7-20 Memory location



The computer comes with double data rate 3 synchronous dynamic random access memory (DDR3-SDRAM) small outline dual inline memory modules (SODIMMs).

DDR3-SDRAM SODIMMs

For proper system operation, the SODIMMs must be:

- industry-standard 204-pin
- unbuffered non-ECC PC3-10600 DDR3-1333 MHz-compliant
- 1.5 volt DDR3-SDRAM SODIMMs

The DDR3-SDRAM SODIMMs must also:

- support CAS latency 9 DDR3 1333 MHz (9-9-9 timing)
- contain the mandatory Joint Electronic Device Engineering Council (JEDEC) specification

In addition, the computer supports:

- 512-Mbit, 1-Gbit, and 2-Gbit non-ECC memory technologies
- single-sided and double-sided SODIMMs
- SODIMMs constructed with x8 and x16 devices; SODIMMs constructed with x4 SDRAM are not supported

 **NOTE:** The system will not operate properly if you install unsupported SODIMMs.

Populating SODIMM sockets

The memory sockets on the system board can be populated with up to four industry-standard SODIMMs. These memory sockets are populated with at least one preinstalled SODIMM. To achieve the maximum memory support, you can populate the system board with up to 16 GB of memory.

There are four SODIMM sockets on the system board, with two sockets per channel. The sockets are labeled DIMM1, DIMM2, DIMM3, and DIMM4. Sockets DIMM1 and DIMM2 operate in memory channel A. Sockets DIMM3 and DIMM4 operate in memory channel B.

Figure 7-21 SODIMM socket locations

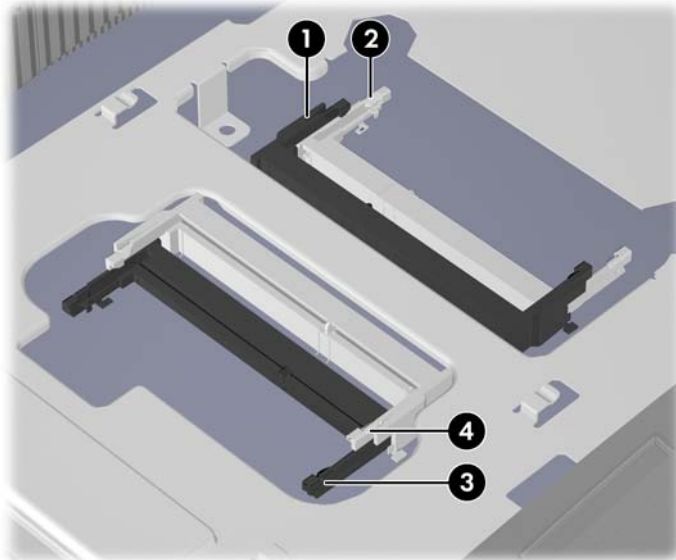

Table 7-1 SODIMM socket locations

| Item | Description | Socket Color |
|------|-------------------------------------------|--------------|
| 1 | DIMM1 socket, Channel A (populate first) | black |
| 2 | DIMM2 socket, Channel A (populate third) | white |
| 3 | DIMM3 socket, Channel B (populate second) | black |
| 4 | DIMM4 socket, Channel B (populate fourth) | white |

NOTE: A SODIMM must occupy the black DIMM1 socket. Otherwise, the system will display a POST error message indicating that a memory module is installed in the wrong socket

The system will automatically operate in single channel mode, dual channel mode, or flex mode, depending on how the SODIMMs are installed.

- The system will operate in single channel mode if the SODIMM sockets are populated in one channel only.
- The system will operate in a higher-performing dual channel mode if the total memory capacity of the SODIMMs in Channel A is equal to the total memory capacity of the SODIMMs in Channel B. The technology and device width can vary between the channels. For example, if Channel A is populated with two 1 GB SODIMMs and Channel B is populated with one 2 GB SODIMM, the system will operate in dual channel mode.
- The system will operate in flex mode if the total memory capacity of the SODIMMs in Channel A is not equal to the total memory capacity of the SODIMMs in Channel B. In flex mode, the channel populated with the least amount of memory describes the total amount of memory assigned to dual channel and the remainder is assigned to single channel. For optimal speed, the channels should be balanced so that the largest amount of memory is spread between the two channels. If one channel will have more memory than the other, the larger amount should be assigned to Channel A. For example, if you are populating the sockets with one 2 GB SODIMM, and three 1 GB SODIMMs, Channel A should be populated with the 2 GB SODIMM and one 1 GB SODIMM, and Channel B should be populated with the other two 1 GB SODIMMs. With this configuration, 4 GB will run as dual channel and 1 GB will run as single channel.

Installing SODIMMS

When facing the rear of the computer, there are four memory sockets located behind the large access panel on the right. You must remove this panel to remove or install memory.

⚠ CAUTION: Static electricity can damage the electronic components of the computer. Before beginning these procedures, ensure that you are discharged of static electricity by briefly touching a grounded metal object.

When handling a memory module, be careful not to touch any of the contacts. Doing so may damage the module.

To remove or install memory modules:

1. Prepare the computer for disassembly (see [Preparing to disassemble the computer on page 34](#)).
2. Remove the right rear panel (see [Rear panels on page 47](#)).

3. To remove a SODIMM, press outward on the two latches on each side of the SODIMM (1) then pull the SODIMM out of the socket (2).

Figure 7-22 Removing a memory module

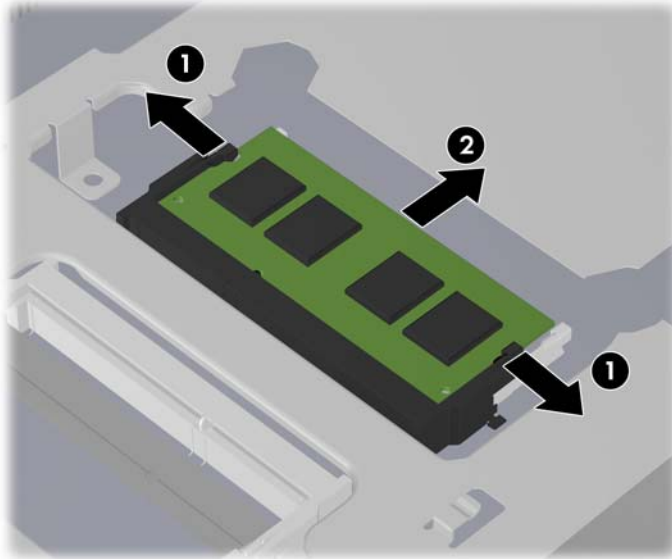

4. To install a SODIMM, slide the new SODIMM into the socket at approximately a 30° angle (1) then press the SODIMM down (2) so that the latches lock it in place.

Figure 7-23 Installing a memory module

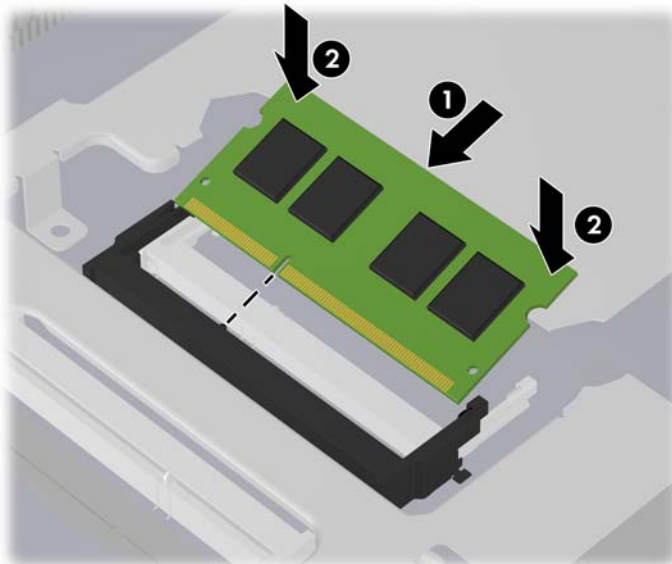

 **NOTE:** A memory module can be installed in only one way. Match the notch on the module with the tab on the memory socket.

5. Reconnect and reconfigure the computer. The computer automatically recognizes the additional memory when you turn on the computer.

Hard drive

| Description | Spare part number |
|--------------------------|-------------------|
| 1000-GB | 636930-001 |
| 750-GB | 639363-001 |
| 500-GB | 636939-001 |
| 320-GB | 634824-001 |
| 250-GB | 636927-001 |
| 160-GB solid-state drive | 646809-001 |
| 80-GB solid-state drive | 607817-001 |

The hard drive is located under the rear panel on the left side of the computer (when viewed from behind). The drive is secured with one captive screw and is housed in a removable cage.

Figure 7-24 Hard drive location



To replace the hard drive:

1. Prepare the computer for disassembly (see [Preparing to disassemble the computer on page 34](#)).
2. Remove the left rear panel (see [Rear panels on page 47](#)).

3. Loosen the captive screw on the side of the hard drive cage that secures the cage to the computer.

Figure 7-25 Loosening the hard drive cage screw

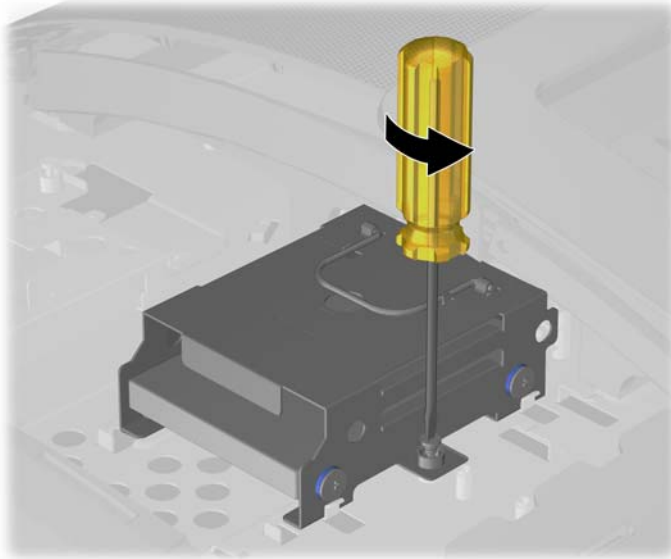

4. Grasp the handle on top of the hard drive cage and slide the cage toward the outer edge of the computer, then lift the cage out of the computer.

Figure 7-26 Removing the hard drive cage

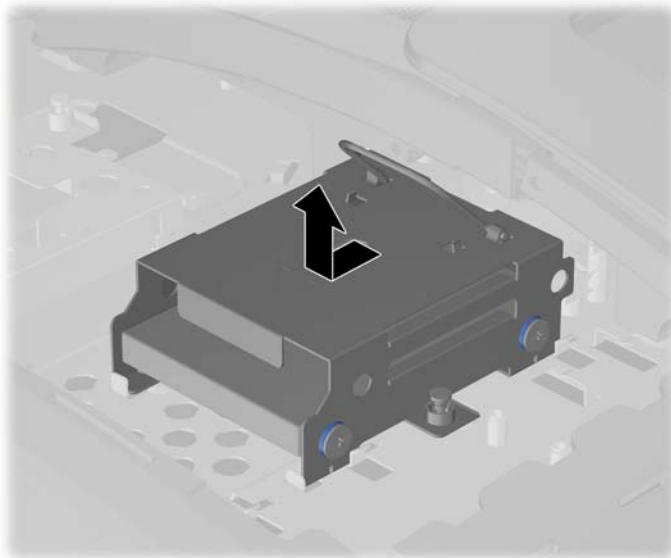

5. To remove the hard drive from the hard drive cage, remove the four screws on the sides of the cage that secure the drive to the cage (1), and then slide the drive out of the cage (2).

Figure 7-27 Removing the hard drive from the cage

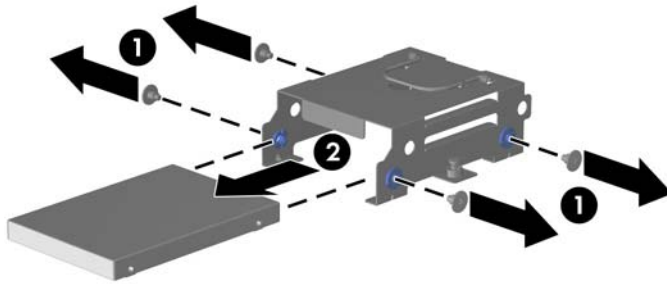

6. Reconnect and reconfigure the computer.

To install a hard drive, reverse the removal procedures.

Inverter board

| Description | Spare part number |
|----------------|-------------------|
| Inverter board | 658982-001 |

The inverter board is located on the left side of the computer on top of the optical drive cage. It is secured with two screws and has two connectors.

Figure 7-28 Inverter board location

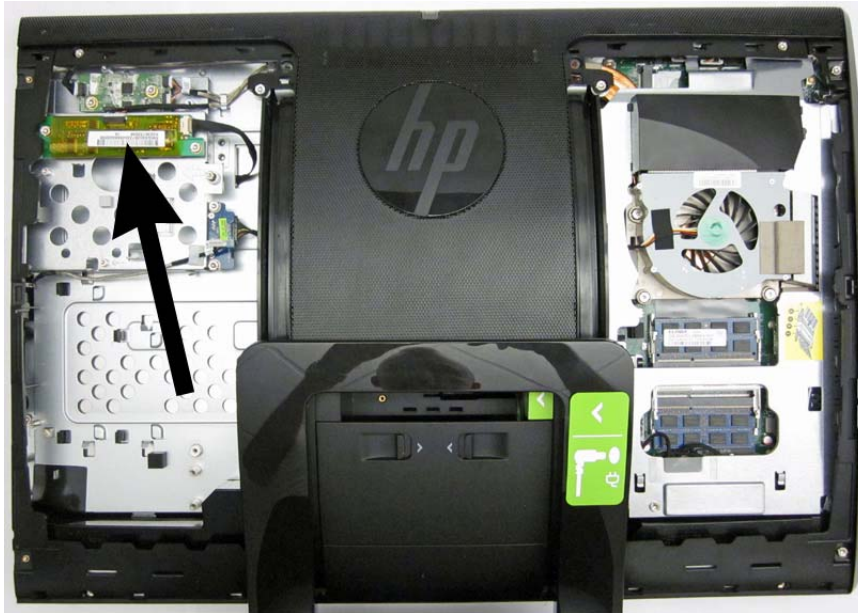

To remove the inverter board:

1. Prepare the computer for disassembly (see [Preparing to disassemble the computer on page 34](#)).
2. Remove the left rear panel (see [Rear panels on page 47](#)).
3. Remove the two screws **(1)** that secure the board to the computer.
4. Disconnect the two cables from the board **(2)**.

 **NOTE:** Be careful not to damage the cables when disconnecting them from the board. Do not pull on the wires.

5. Remove the inverter board from the computer (3).

Figure 7-29 Removing the Inverter board

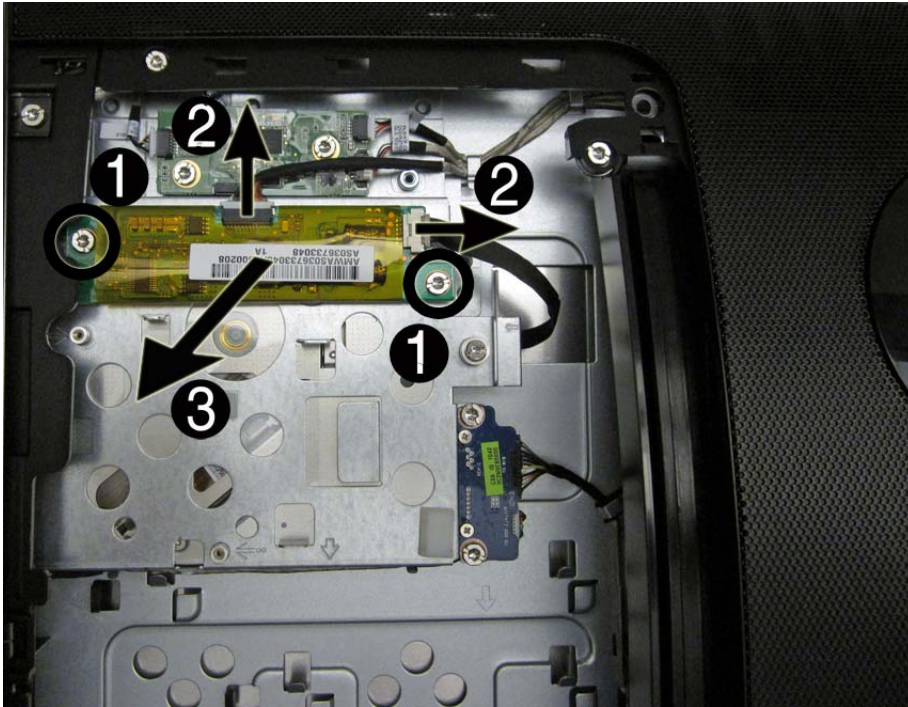

To install the inverter board, reverse the removal procedures.

Optical drive connector board

| Description | Spare part number |
|--------------------------------------|-------------------|
| Optical drive connector board | 652311-001 |
| Optical drive transfer cable, 275 mm | 652286-001 |

The optical drive connector board is located on the left side of the computer (when viewed from behind). It is secured by two screws and has two connectors – one to the system board, one to the optical drive eject board.

Figure 7-30 Optical drive connector board location

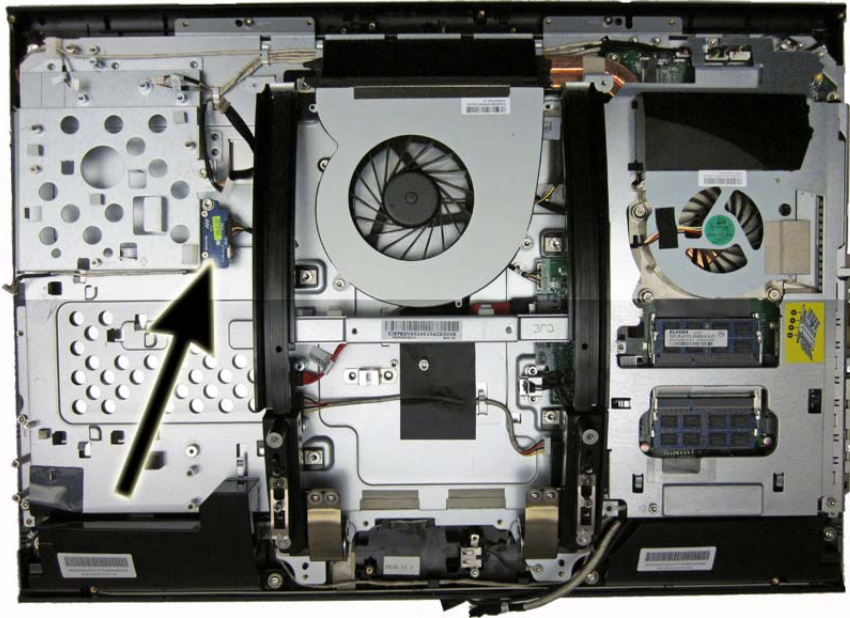

To remove the optical drive connector board:

1. Prepare the computer for disassembly (see [Preparing to disassemble the computer on page 34](#)).
2. Remove the left rear panel (see [Rear panels on page 47](#)).
3. Disconnect the two cables **(1)** from the board.



NOTE: Be careful not to damage the cable when disconnecting it from the board. Do not pull on the wires.

4. Remove two screws **(2)** that secure the board to the computer.

5. Pull the board away from the optical drive bracket, and then remove it from the computer (3).

Figure 7-31 Removing the optical drive connector board

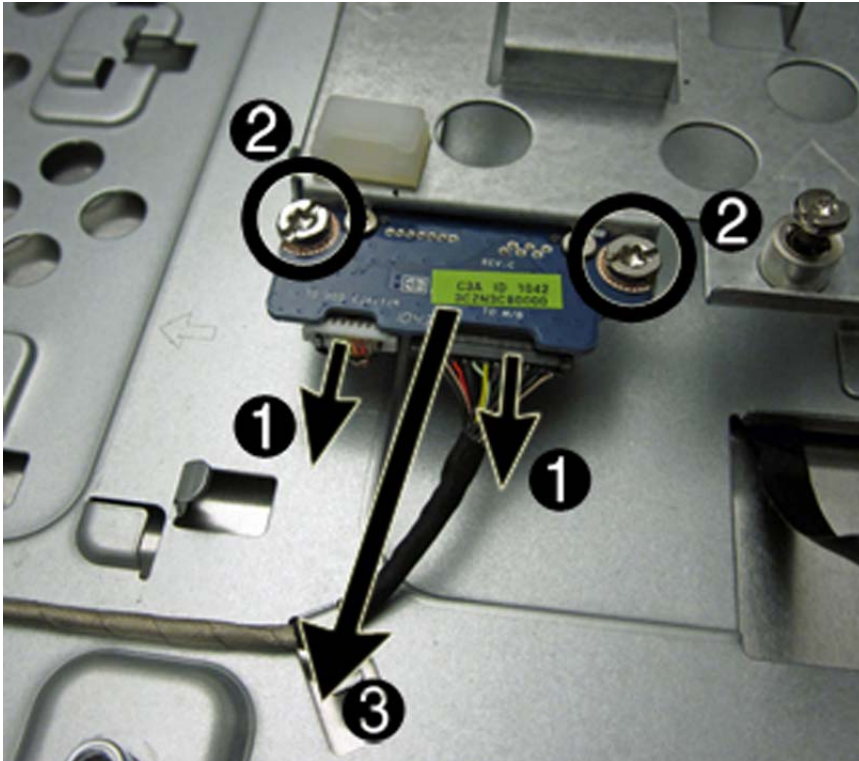

6. Remove the board from the computer.

To install the optical drive connector board, reverse the removal procedures.

Left cap

| Description | Spare part number |
|---------------------------------|-------------------|
| Left side cap, no optical drive | 658989-001 |
| Left side cap, 1394 | 670181-001 |

The left cap is located on the left side of the computer. You must remove it to remove the optical drive, optical drive eject board, rear logo cover, and main rear frame.

Figure 7-32 Left cap location



To remove the left cap:

1. Prepare the computer for disassembly (see [Preparing to disassemble the computer on page 34](#)).
2. Remove the left rear panel (see [Rear panels on page 47](#)).
3. Move the two screws **(1)** that secure the cap to the computer.

4. Rotate the cap to disengage it from the computer (2), and then remove it (3).

Figure 7-33 Removing the left side cap

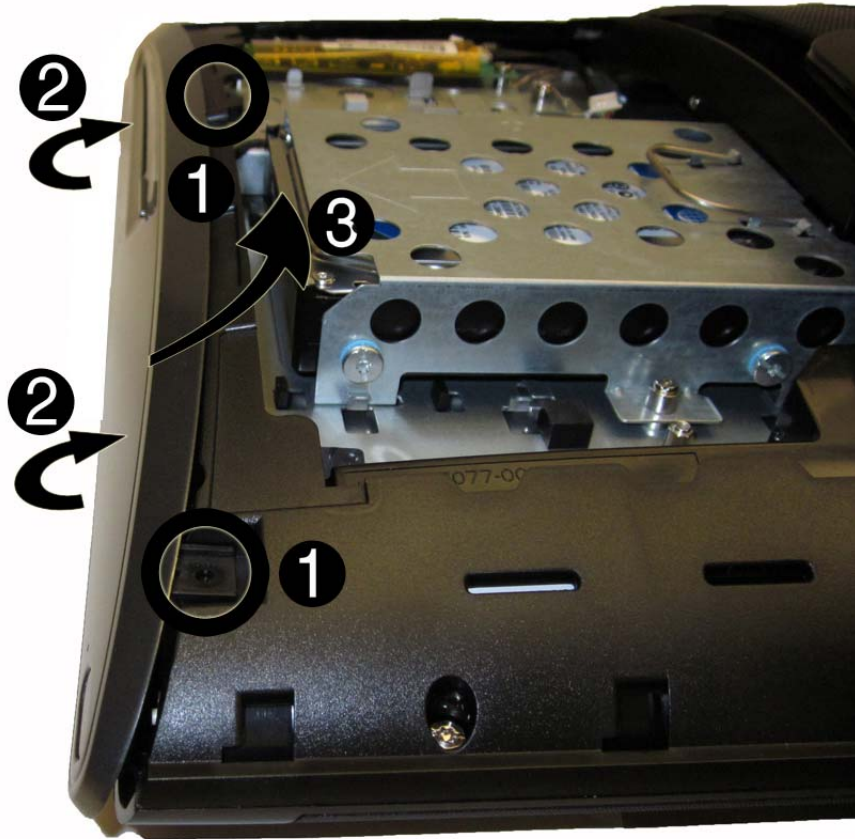

To install an left cap, reverse the removal procedures.

Optical drive

| Description | Spare part number |
|----------------------------------|-------------------|
| HP SuperMulti DVD Writer Drive | 583092-001 |
| HP Slim Slot Blu-ray Combo Drive | 583093-001 |

The optical drive is located under the drive cover on the left side of the computer (when viewed from behind). It is secured with one screw. You must remove the left side cap to remove the optical drive.

Figure 7-34 Optical drive location



To remove the optical drive:

1. Prepare the computer for disassembly (see [Preparing to disassemble the computer on page 34](#)).
2. Remove the left rear panel (see [Rear panels on page 47](#)).
3. Remove the left cap (see [Left cap on page 61](#)).

4. Loosen the captive screw (1) that secures the drive to the computer, and then push on the drive bracket (2) to slide the drive out of the computer (3).

Figure 7-35 Removing the optical drive



5. If you need to remove the drive bracket from the drive, remove the two screws (1) that secure the bracket to the drive, and then remove the bracket from the drive (2).

Figure 7-36 Removing the optical drive bracket



To install an optical drive, reverse the removal procedures.

Optical drive eject board

| Description | Spare part number |
|-----------------------------------|-------------------|
| Optical drive eject board | 652312-001 |
| Optical drive eject cable, 190 mm | 652299-001 |

The optical drive eject board is located under the left side cap. It is secured with one screw and has one connector.

Figure 7-37 Optical drive eject board location

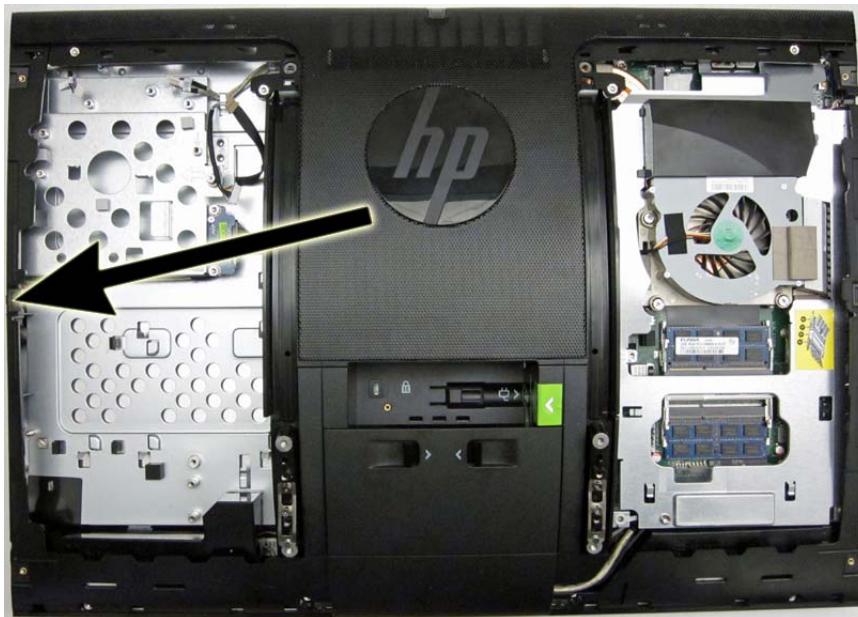

To remove the optical drive eject board:

1. Prepare the computer for disassembly (see [Preparing to disassemble the computer on page 34](#)).
2. Remove the left rear panel (see [Rear panels on page 47](#)).
3. Remove the left side cap (see [Optical drive on page 63](#)).

4. From the outside of the computer, remove the screw that secures the board to the computer.

Figure 7-38 Removing the optical drive eject board screw

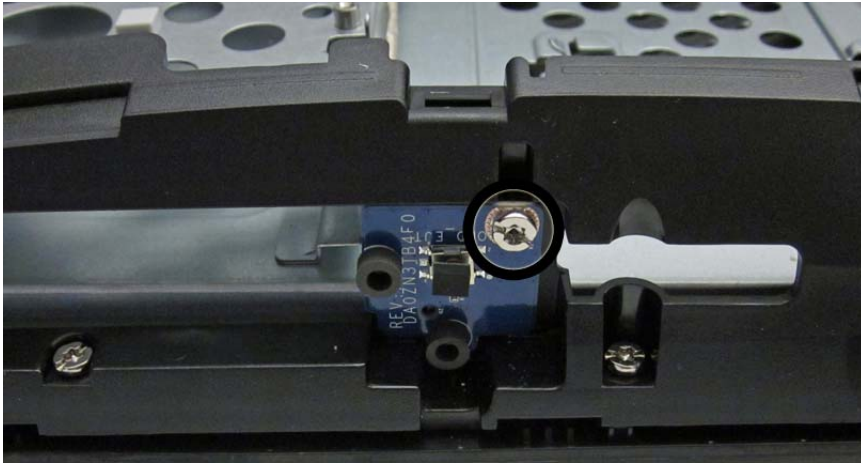

5. From the inside of the computer, disconnect the cable from the board.



NOTE: Be careful not to damage the cable when disconnecting it from the connector. Do not pull on the wires.

Figure 7-39 Disconnecting the optical drive eject board cable

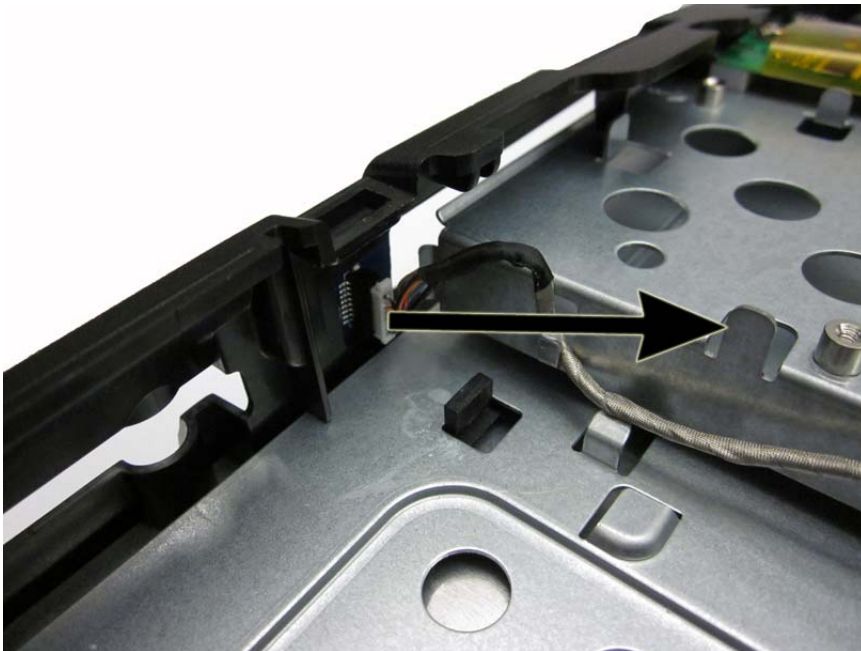

6. Remove the board from the computer.

To install the optical drive eject board, reverse the removal procedures.

Right cap

| Description | Spare part number |
|-------------|-------------------|
| Right cap | 670182-001 |

The right cap is located along the right side of the computer (when viewed from behind). It is secured with two screws, and it houses the volume board. You do not have to remove the volume board when removing the cap if you disconnect the volume board cable from the system board.

Figure 7-40 Right cap location

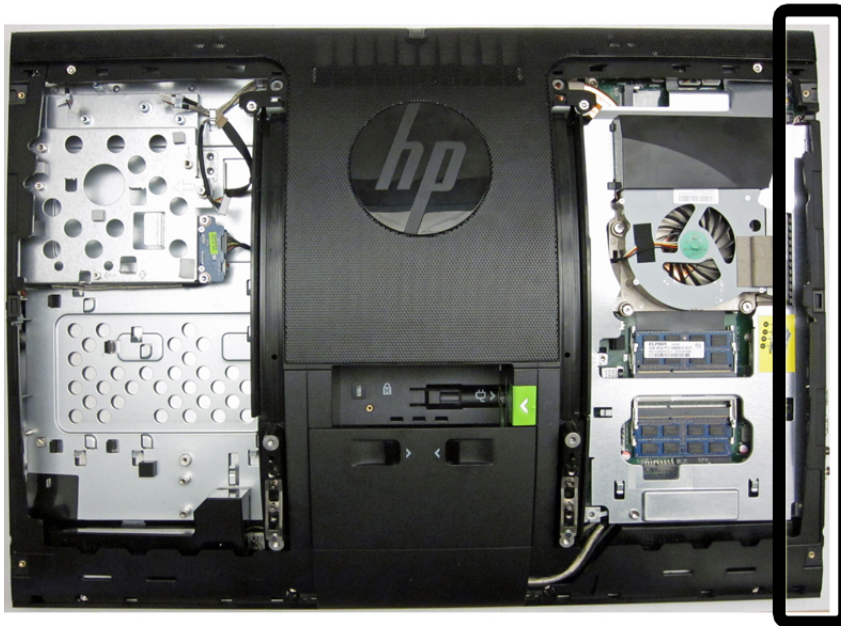

To remove the right cap:

1. Prepare the computer for disassembly (see [Preparing to disassemble the computer on page 34](#)).
2. Remove the right rear panel (see [Rear panels on page 47](#)).
3. Move the two screws **(1)** that secure the right side cap to the computer.

4. Rotate the cap to disengage it from the computer (2), and then remove it far enough to gain access to the volume board cable connector (3).

Figure 7-41 Removing the right cap

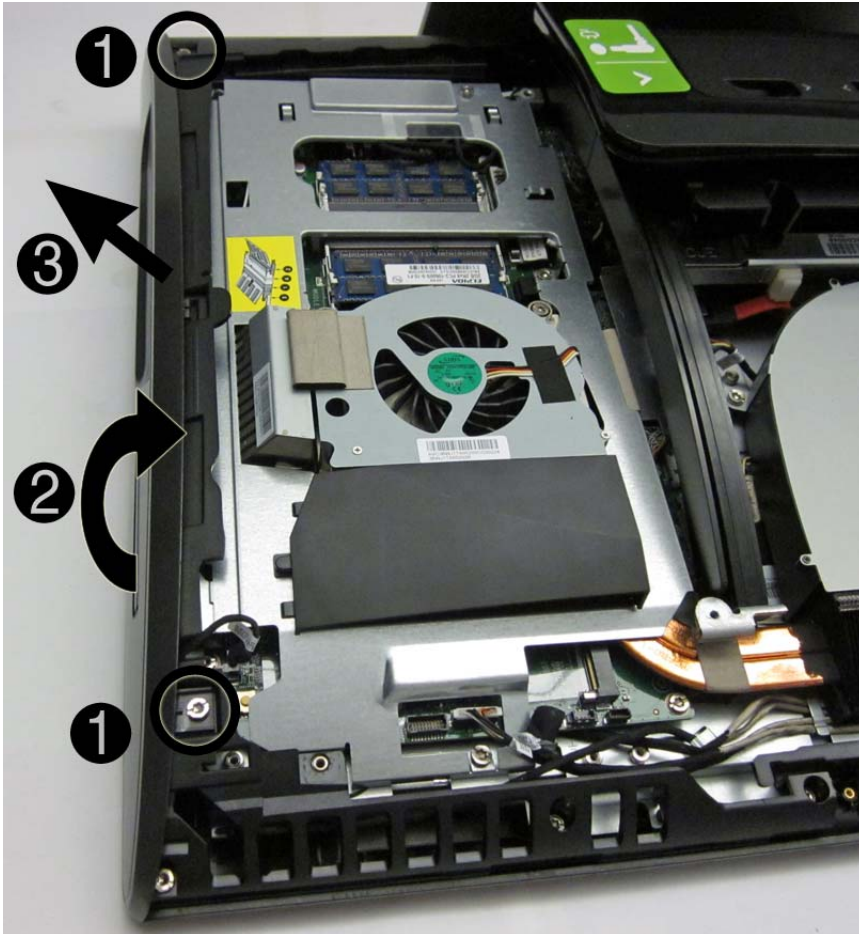

5. Disconnect the volume board cable from the system board.

Figure 7-42 Disconnecting the volume board cable



6. Remove the cap from the computer.

To install the right cap, reverse the removal procedures.

Volume button board

| Description | Spare part number |
|---------------------|-------------------|
| Volume button board | 652306-001 |

The volume button board is located in the right side cap. It is secured with two screws and has one connector.

Figure 7-43 Volume button board location

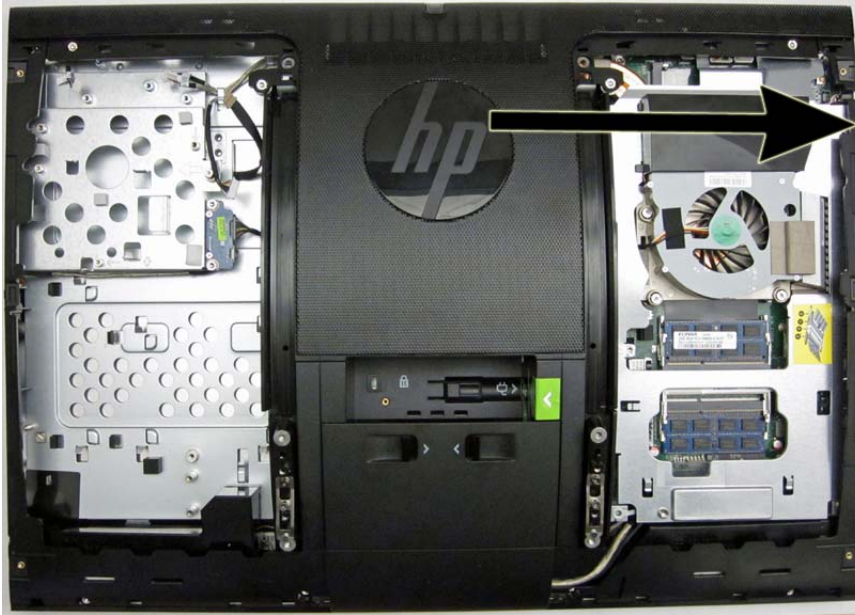

To remove the volume board:

1. Prepare the computer for disassembly (see [Preparing to disassemble the computer on page 34](#)).
2. Remove the right rear panel (see [Rear panels on page 47](#)).
3. Remove the right cap (see [Right cap on page 67](#)).
4. Remove the two screws **(1)** that secure the board to the right cap.

5. Lift the board from the cap (2).

Figure 7-44 Removing the volume button board

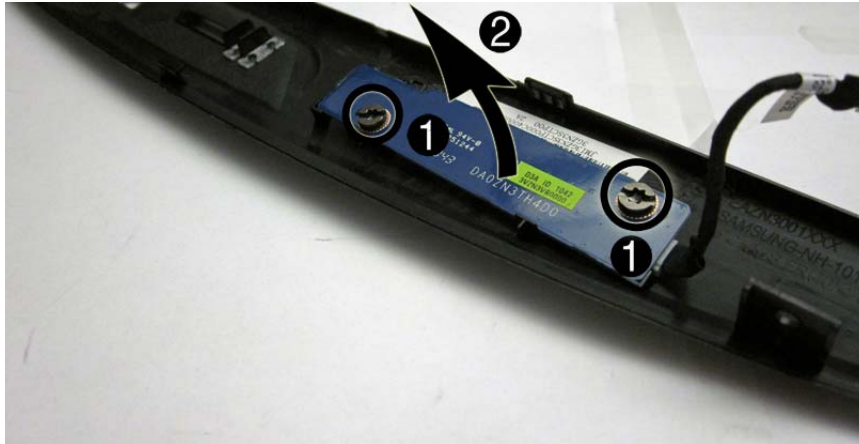

To install the volume button board, reverse the removal procedures.

Rear logo cover

The rear logo cover is secured with four screws.

To remove the rear logo cover:

1. Prepare the computer for disassembly (see [Preparing to disassemble the computer on page 34](#)).
2. Remove the left and right rear panels (see [Rear panels on page 47](#)).
3. Remove the 4 screws that secure the cover to the computer.
4. Pry the cover up to disengage it from the computer, and then pull it toward the top and off the computer. You may experience significant resistance under the HP logo.

Figure 7-45 Removing the rear logo cover

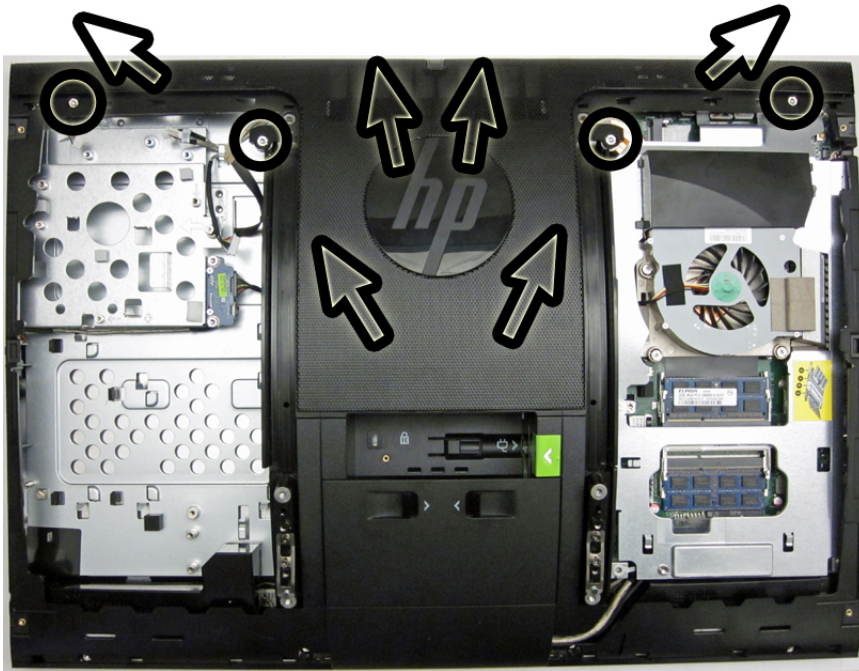

To replace the rear logo cover, reverse the removal procedures.

Webcam module

| Description | Spare part number |
|----------------------------|-------------------|
| Webcam module without DMIC | 652277-001 |
| Webcam module, 2.0 MP, FHD | 658985-001 |
| Webcam lens cover | 654598-001 |
| Webcam wheel cap | 658986-001 |

The webcam module is located at the top of the computer. It is secured with two screws and has one connector.

Figure 7-46 Webcam module location



To remove the webcam module:

1. Prepare the computer for disassembly (see [Preparing to disassemble the computer on page 34](#)).
2. Remove the left and right rear panels (see [Rear panels on page 47](#)).
3. Remove the rear logo cover (see [Rear logo cover on page 72](#)).
4. Remove the two screws **(1)** that secure the webcam module to the computer.
5. Disconnect the cable from the system board **(2)**.

6. Remove the module from the computer (3).

Figure 7-47 Removing the webcam module

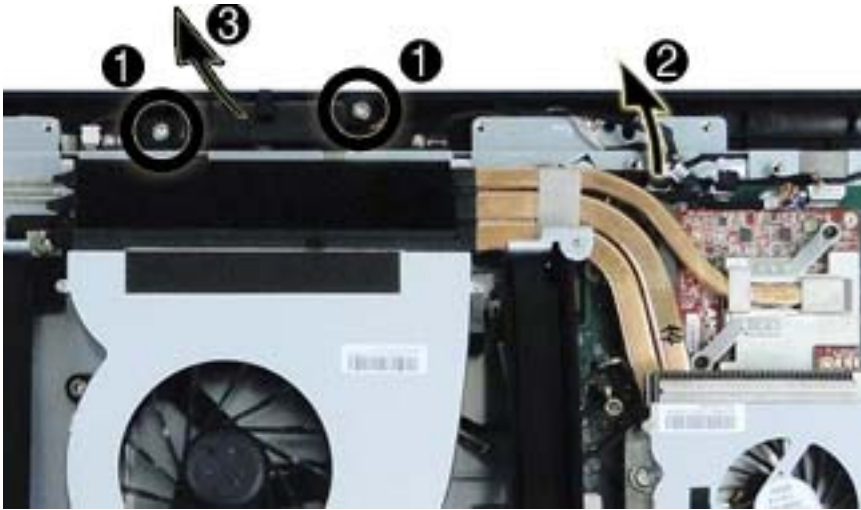

To install a webcam module, reverse the removal procedures.

Main rear frame

The main rear frame is secured with 15 screws. To remove it, you must first remove the rear logo cover, which is held on with four screws.

To remove the main rear frame:

1. Prepare the computer for disassembly (see [Preparing to disassemble the computer on page 34](#)).
2. Remove the stand (see [Stand on page 35](#)).
3. Remove the left and right rear panels (see [Rear panels on page 47](#)).
4. Remove the left cap (see [Left cap on page 61](#)).
5. Remove the right cap (see [Right cap on page 67](#)).
6. Remove the rear logo cover (see [Rear logo cover on page 72](#)).
7. Remove the 15 screws that secure the frame to the computer, as follows:
 - Top: 6 screws
 - Bottom: 4 screws
 - Left: 3 screws
 - Right: 2 screws

 **NOTE:** Be sure to mark the locations of the rear frame screws as you remove them. If you also remove the display panel, it is difficult to determine which screws are used for which component if you do not have them marked.

Figure 7-48 Removing the main rear frame



8. Lift the frame from the computer.

To replace the main rear frame, reverse the removal procedures.

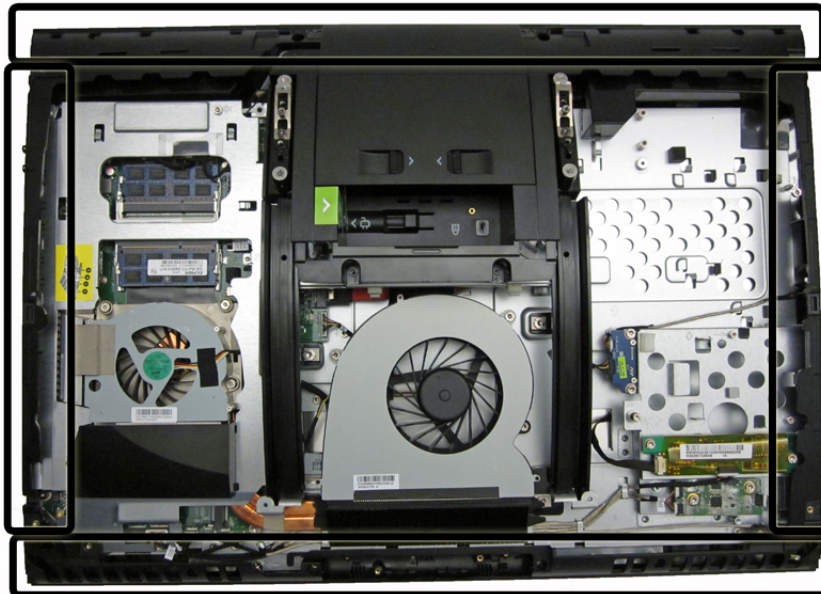
Power button board

| Description | Spare part number |
|--------------------|-------------------|
| Power button board | 652305-001 |

The power button board is located under the left side cap near the bottom of the computer. It is secured with one screw and has one connector.

Figure 7-49 Power button board location

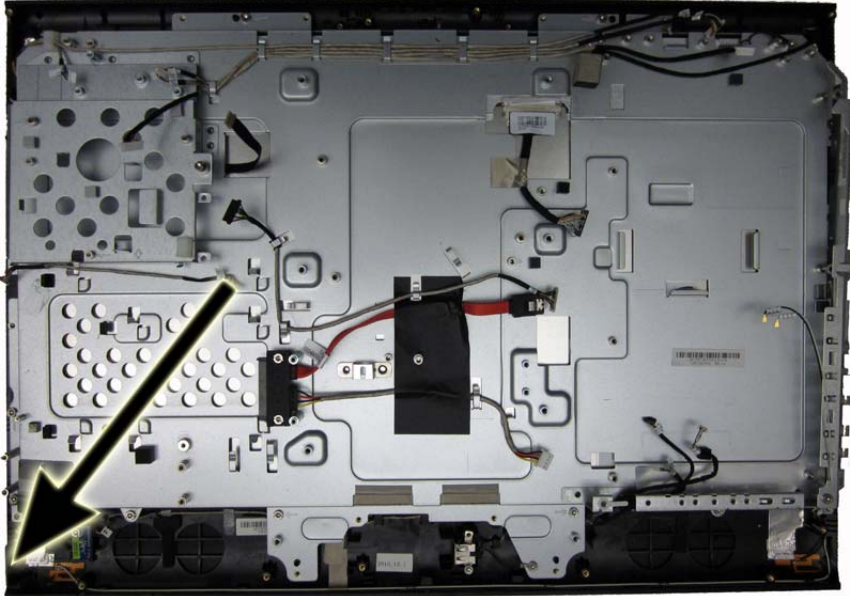

To remove the power button board:

1. Prepare the computer for disassembly (see [Preparing to disassemble the computer on page 34](#)).
2. Remove the stand (see [Stand on page 35](#)).
3. Remove the right and left rear panels (see [Rear panels on page 47](#)).
4. Remove the left cap (see [Left cap on page 61](#)).
5. Remove the right cap (see [Right cap on page 67](#)).
6. Remove the rear logo cover (see [Rear logo cover on page 72](#)).
7. Remove the rear main frame (see [Main rear frame on page 75](#)).
8. Lift the left side of the board first, and then pull the board out of the holder enough to access the connector (1).

9. Disconnect the cable from the board **(2)**, and then remove the board from the computer.

 **NOTE:** Be careful not to damage the cable when disconnecting it from the connector. Do not pull on the wires.

Figure 7-50 Removing the power button board



To install the power button board, reverse the removal procedures.

System board shield

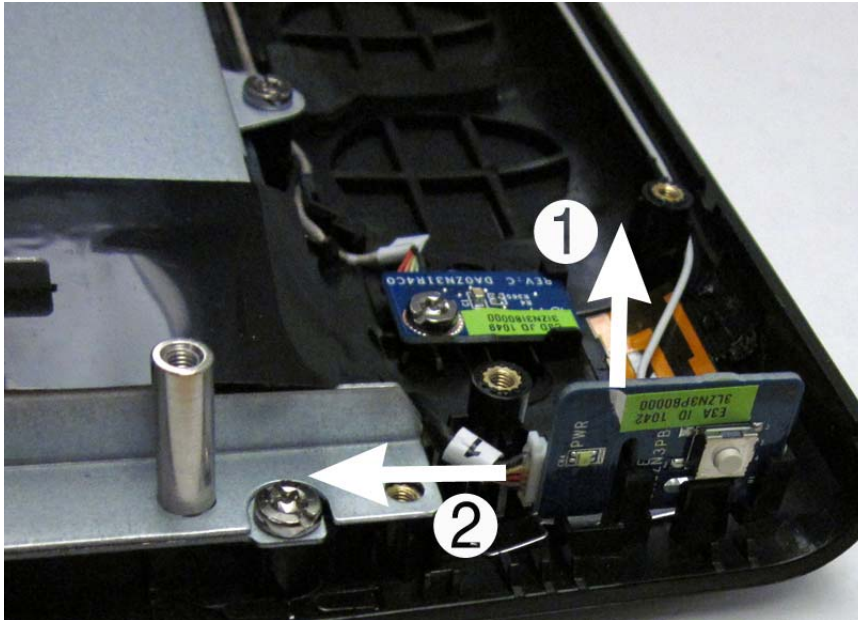
The system board shield sits above the system board. It is secured with three screws.

To remove the system board shield:

1. Prepare the computer for disassembly (see [Preparing to disassemble the computer on page 34](#)).
2. Remove the stand (see [Stand on page 35](#)).
3. Remove the right and left rear panels (see [Rear panels on page 47](#)).
4. Remove the left cap (see [Left cap on page 61](#)).
5. Remove the right cap (see [Right cap on page 67](#)).
6. Remove the rear logo cover (see [Rear logo cover on page 72](#)).
7. Remove the rear main frame (see [Main rear frame on page 75](#)).
8. Remove the three screws that secure the shield to the computer **(1)**.
9. Disconnect the cable from the CONVER DB CONN system board connector **(2)**.

10. Lift the left side of the shield first (3), and then pull the shield up and off the system board.

Figure 7-51 Removing the system board shield

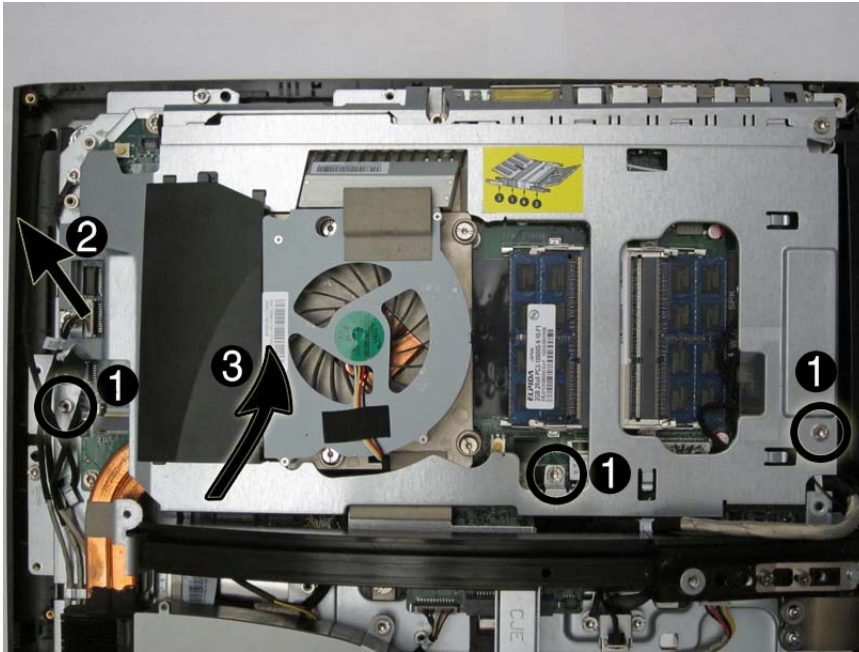

To install the system board shield, reverse the removal procedures.

When replacing the shield, make sure to place the five tabs on the right side of the shield into their slots in the computer before placing the shield atop the system board.

Figure 7-52 Replacing the system board shield

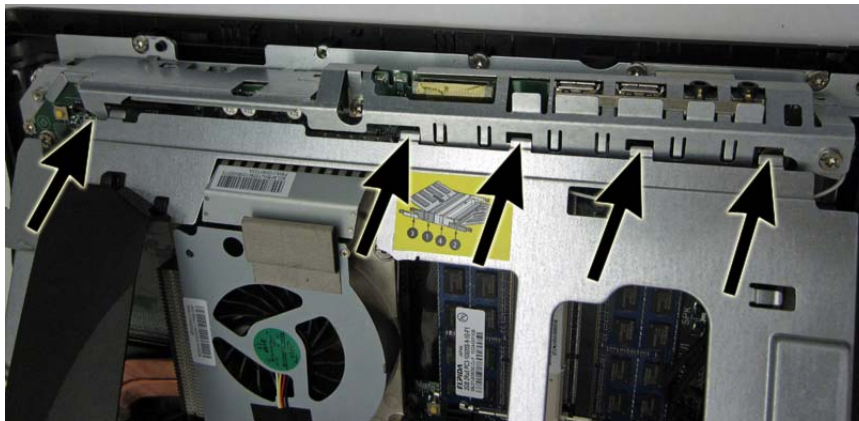

Speakers

| Description | Spare part number |
|---------------|-------------------|
| Right speaker | 652274-001 |
| Left speaker | 652275-001 |

The speakers are located at the bottom of the computer. Two separate speakers are each secured by two screws.

Figure 7-53 Speaker location

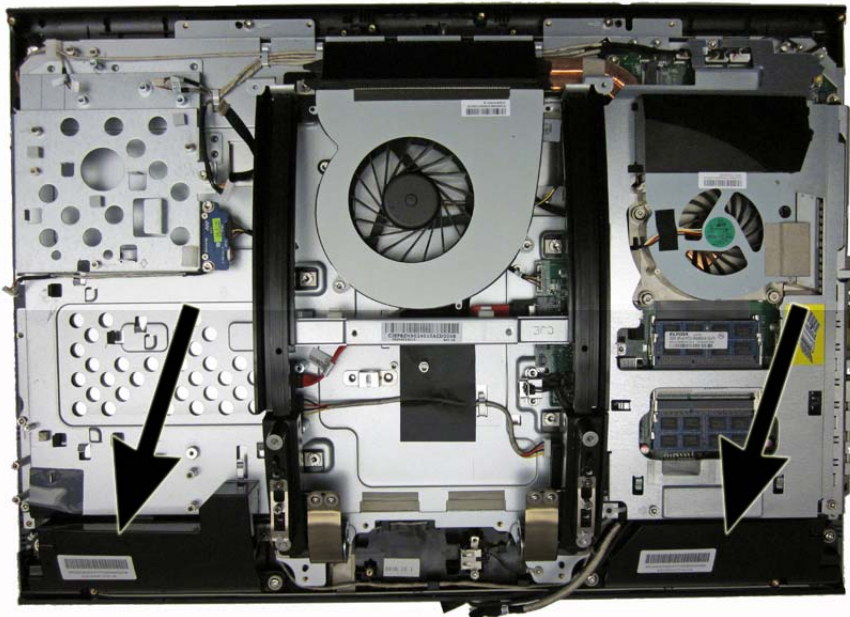

To remove the speakers:

1. Prepare the computer for disassembly (see [Preparing to disassemble the computer on page 34](#)).
2. Remove the stand (see [Stand on page 35](#)).
3. Remove the right and left rear panels (see [Rear panels on page 47](#)).
4. Remove the left cap (see [Left cap on page 61](#)).
5. Remove the right cap (see [Right cap on page 67](#)).
6. Remove the rear logo cover (see [Rear logo cover on page 72](#)).
7. Remove the rear main frame (see [Main rear frame on page 75](#)).
8. Remove the system board shield (see [System board shield on page 77](#)).
9. Disconnect the speaker cables from the system board connectors **(1)**.
10. Remove the speaker cables from their routing paths.
11. Remove two screws **(2)** that secure each speaker to the computer.

12. Lift the speakers straight up and out of the computer (3).

Figure 7-54 Removing the speakers

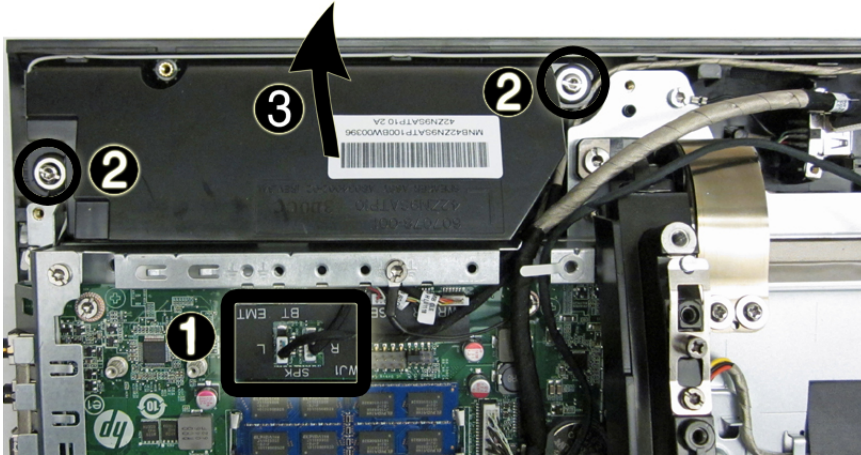
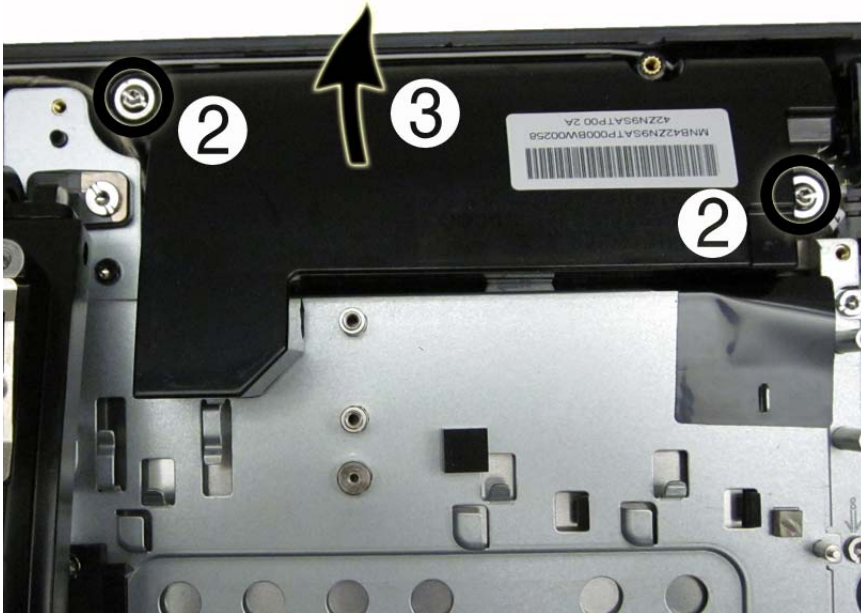

Figure 7-55 Removing the speakers



To install the speakers, reverse the removal procedures.

Infrared sensor board

| Description | Spare part number |
|-----------------------|-------------------|
| Infrared sensor board | 652307-001 |

The infrared board is located on the bottom left side of the computer, under the left speaker. It is secured with one screw and has one connector.

Figure 7-56 Infrared board location

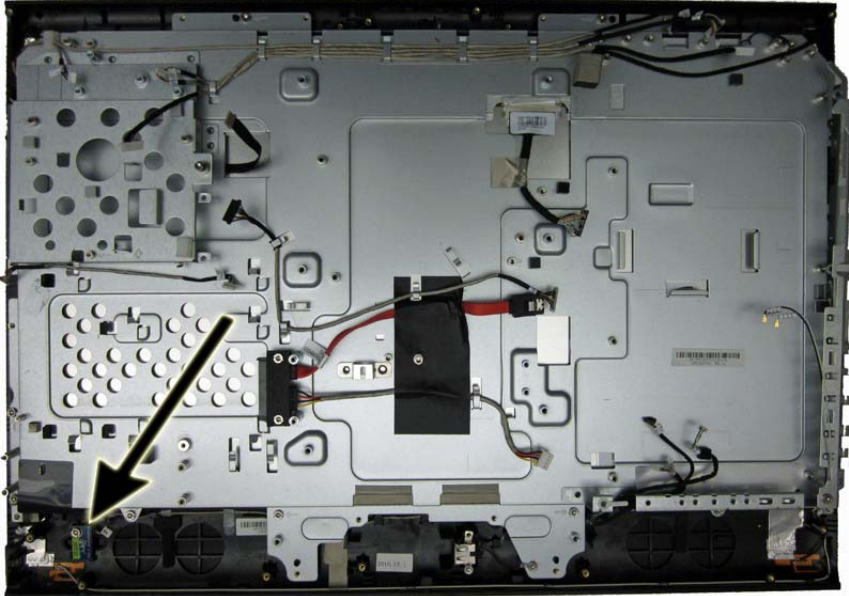

To remove the infrared board:

1. Prepare the computer for disassembly (see [Preparing to disassemble the computer on page 34](#)).
2. Remove the stand (see [Stand on page 35](#)).
3. Remove the right and left rear panels (see [Rear panels on page 47](#)).
4. Remove the left cap (see [Left cap on page 61](#)).
5. Remove the right cap (see [Right cap on page 67](#)).
6. Remove the rear logo cover (see [Rear logo cover on page 72](#)).
7. Remove the rear main frame (see [Main rear frame on page 75](#)).
8. Remove the speakers (see [Speakers on page 79](#)).
9. Disconnect the cable from the board **(1)** and remove the screw **(2)** that secures the board to the computer.

 **NOTE:** Be careful not to damage the cable when disconnecting it from the connector. Do not pull on the wires.

10. Lift the board from the computer (3).

Figure 7-57 Removing the infrared board

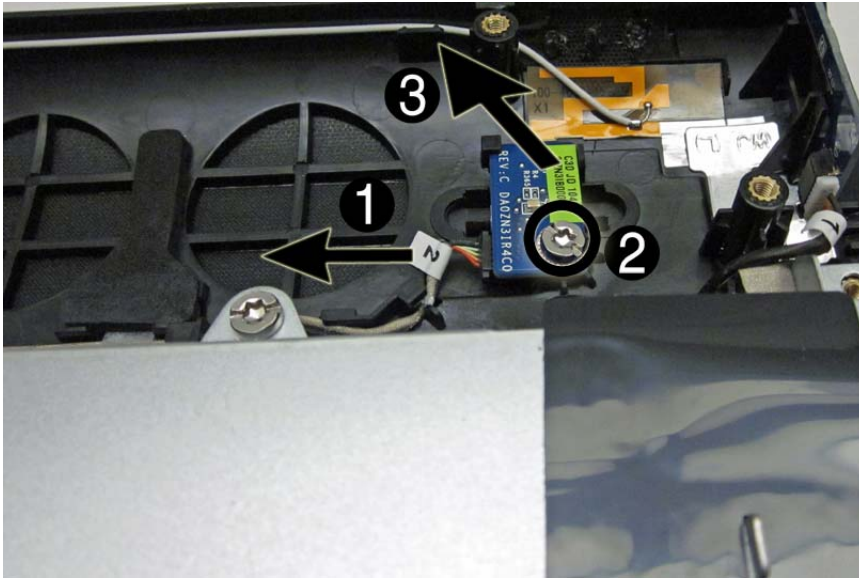

To install the infrared board, reverse the removal procedures.

Fan

| Description | Spare part number |
|-------------|-------------------|
| Fan | 652321-001 |

The fan is located near the top of the computer. It is secured with three screws. You do not have to remove the heat sink to remove it.

Figure 7-58 Fan location

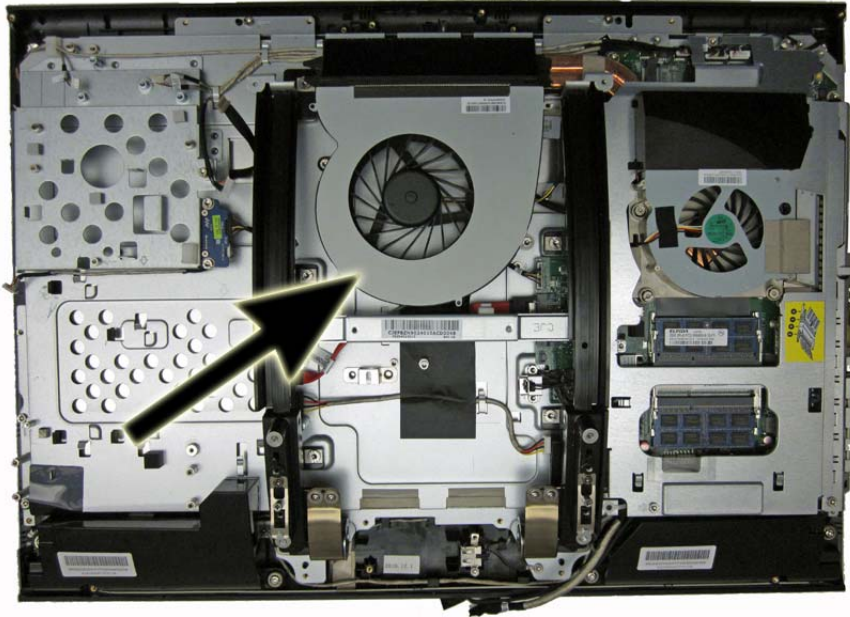

To remove the fan:

1. Prepare the computer for disassembly (see [Preparing to disassemble the computer on page 34](#)).
2. Remove the stand (see [Stand on page 35](#)).
3. Remove the right and left rear panels (see [Rear panels on page 47](#)).
4. Remove the left cap (see [Left cap on page 61](#)).
5. Remove the right cap (see [Right cap on page 67](#)).
6. Remove the rear logo cover (see [Rear logo cover on page 72](#)).
7. Remove the rear main frame (see [Main rear frame on page 75](#)).
8. Remove the system board shield (see [System board shield on page 77](#)).
9. Disconnect the fan cable from the system board connector **(1)**.
10. Remove the three screws that secure the fan to the computer **(2)**.

11. Lift the fan from the computer (3).

Figure 7-59 Removing the fan

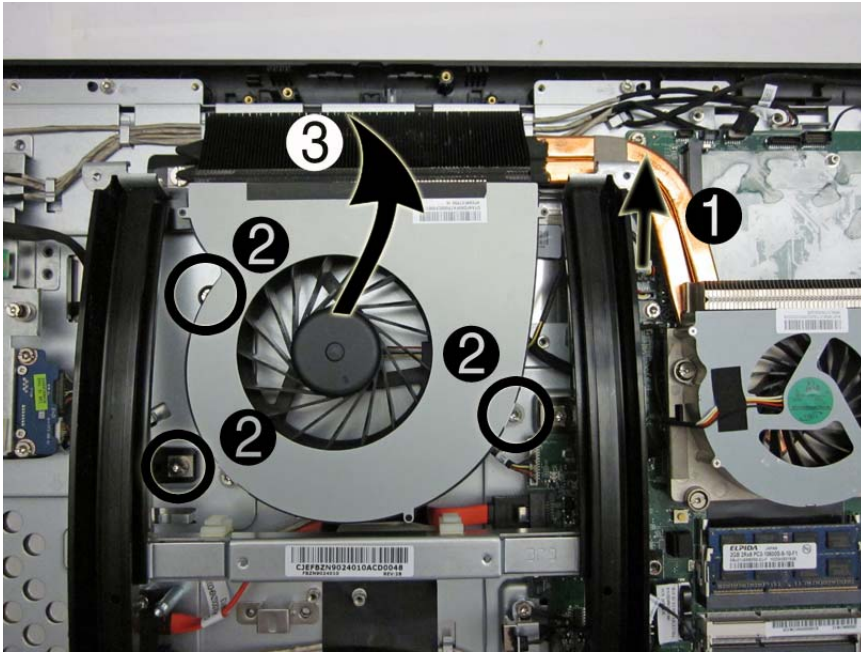

To install the fan, reverse the removal procedures.

Fan sink (Thermal module)

| Description | Spare part number |
|-----------------------------------------------------------------------|-------------------|
| Fan sink (thermal module) for use in computers with discrete graphics | 658987-001 |
| Fan sink (thermal module) for use in computers with UMA graphics | 658988-001 |

The fan sink is secured with four screws. You do not have to remove the chassis fan to remove the it.

Figure 7-60 Fan location

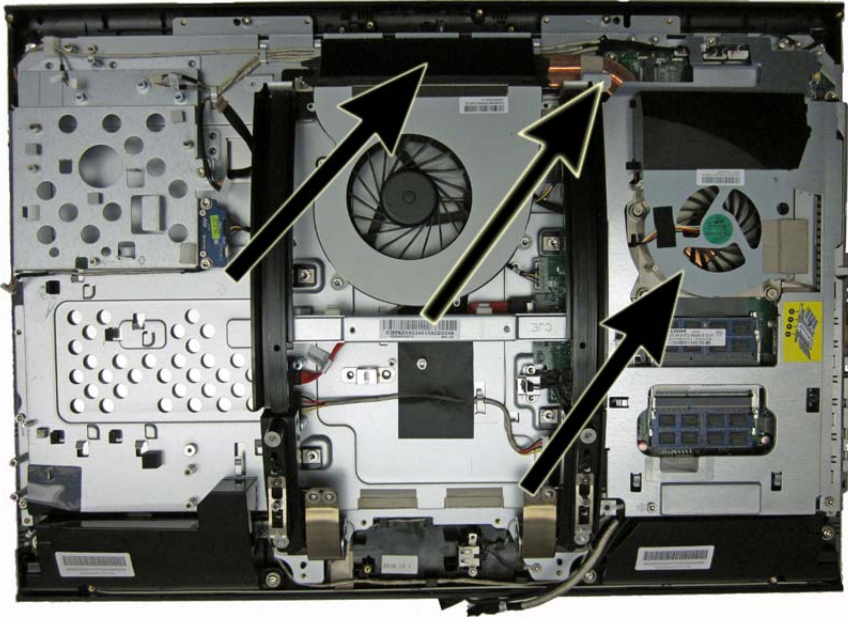

To remove the fan sink:

1. Prepare the computer for disassembly (see [Preparing to disassemble the computer on page 34](#)).
2. Remove the stand (see [Stand on page 35](#)).
3. Remove the right and left rear panels (see [Rear panels on page 47](#)).
4. Remove the left cap (see [Left cap on page 61](#)).
5. Remove the right cap (see [Right cap on page 67](#)).
6. Remove the rear logo cover (see [Rear logo cover on page 72](#)).
7. Remove the rear main frame (see [Main rear frame on page 75](#)).
8. Remove the system board shield (see [System board shield on page 77](#)).
9. In the order indicated by the numbers stamped into the heat sink, remove the four screws **(1)** that secure the fan sink to the system board.
10. Disconnect the fan cable from the system board **(2)**.

- Slide the fan sink toward the top of the computer (3), and then lift it off the system board .

Figure 7-61 Removing the fan sink

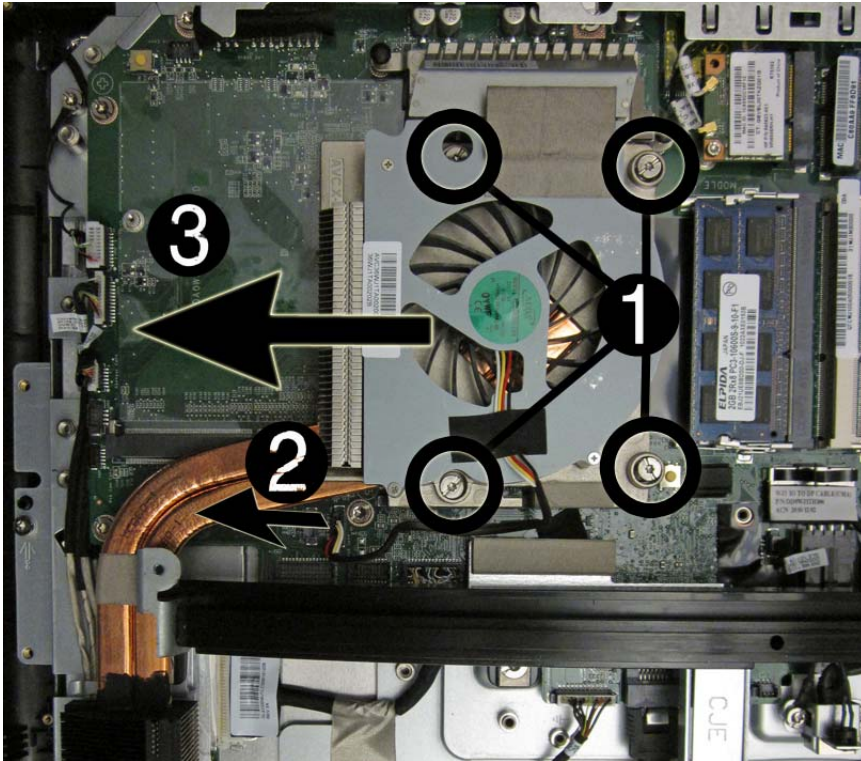

To replace the fan sink, reverse the removal procedures.

Processor

| Description | Spare part number |
|-------------------------------------------|-------------------|
| Intel Core i7 processor | |
| 2600 (3.4-GHz, 8-MB L3 cache) | 638632-001 |
| Intel Core i5 processors | |
| 2500 (3.3-GHz, 6-MB L3 cache) | 638631-001 |
| 2400 (3.1-GHz, 6-MB L3 cache) | 638630-001 |
| 2300 (2.8-GHz, 6-MB L3 cache) | 654601-001 |
| Intel Core i3 processors | |
| 2120 (3.3-GHz, 3-MB L3 cache) | 638629-001 |
| 2100 (3.1-GHz, 3-MB L3 cache) | 638628-001 |
| Intel Pentium Dual-Core processors | |
| G850 (2.9-GHz, 3-MB L3 cache) | 655973-001 |
| G840 (2.8-GHz, 3-MB L3 cache) | 655972-001 |
| G620 (2.6-GHz, 3-MB L3 cache) | 655971-001 |

To remove the processor:

1. Prepare the computer for disassembly (see [Preparing to disassemble the computer on page 34](#)).
2. Remove the stand (see [Stand on page 35](#)).
3. Remove the right and left rear panels (see [Rear panels on page 47](#)).
4. Remove the left cap (see [Left cap on page 61](#)).
5. Remove the right cap (see [Right cap on page 67](#)).
6. Remove the rear logo cover (see [Rear logo cover on page 72](#)).
7. Remove the rear main frame (see [Main rear frame on page 75](#)).
8. Remove the system board shield (see [System board shield on page 77](#)).
9. Remove the fan sink (see [Fan sink \(Thermal module\) on page 85](#)).
10. Rotate the locking lever to its full open position **(1)**.
11. Lift the processor cover **(2)**.
12. Carefully lift the processor from the socket **(3)**.

⚠ CAUTION: Do NOT handle the pins in the processor socket. These pins are very fragile and handling them could cause irreparable damage. Once pins are damaged it may be necessary to replace the system board.

CAUTION: The heat sink must be installed within 24 hours of installing the processor to prevent damage to the processor's solder connections.

Figure 7-62 Removing the processor

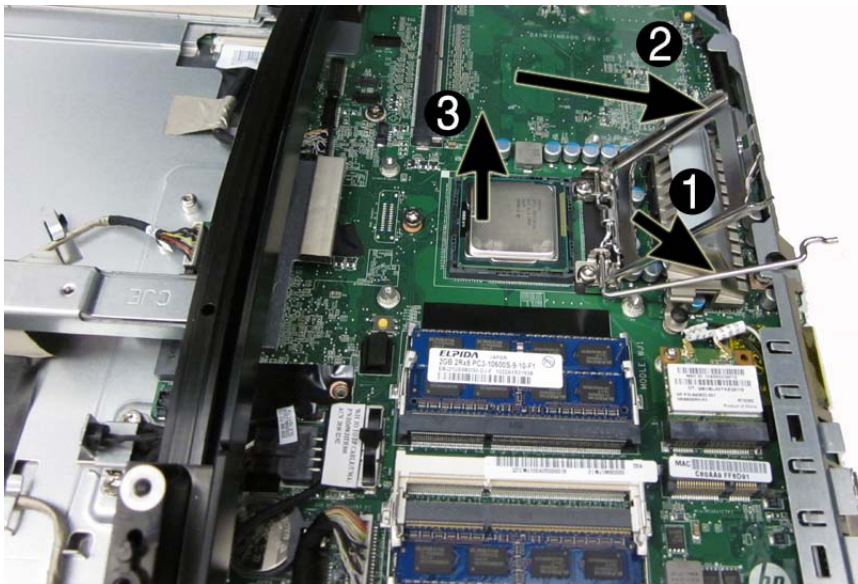

To install a new processor:

1. Place the processor in its socket and close the retainer.
2. Secure the locking lever.

If reusing the existing heat sink, go to step 3.

If using a new heat sink, go to step 5.

3. If reusing the existing heat sink, clean the bottom of the heat sink with the alcohol pad provided in the spares kit.
4. Apply the thermal material provided in the spares kit to the top of the processor and install the heat sink atop the processor.
5. If using a new heat sink, remove the protective covering from the bottom of the heat sink and place it in position atop the processor.

Hard drive connector

The hard drive connector is located near the middle of the computer. You must remove the stand bracket get to the connector's screws. It is secured with two screws and has two connectors. The cables are taped to the computer.

Figure 7-63 Hard drive connector location

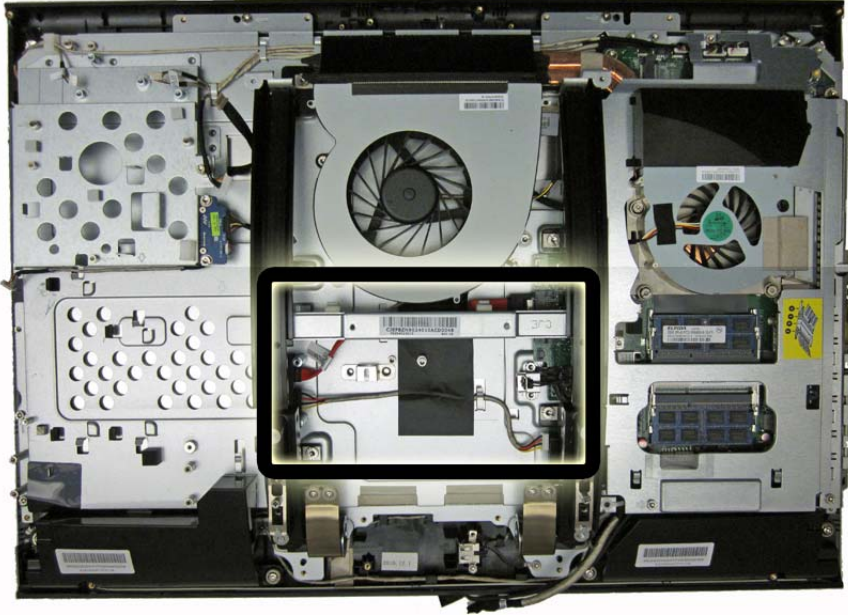

To remove the hard drive connector:

1. Prepare the computer for disassembly (see [Preparing to disassemble the computer on page 34](#)).
2. Remove the stand (see [Stand on page 35](#)).
3. Remove the right and left rear panels (see [Rear panels on page 47](#)).
4. Remove the left cap (see [Left cap on page 61](#)).
5. Remove the right cap (see [Right cap on page 67](#)).
6. Remove the rear logo cover (see [Rear logo cover on page 72](#)).
7. Remove the rear main frame (see [Main rear frame on page 75](#)).

8. Remove the stand bracket by removing the eight screws (1) that secure the bracket to the computer, and then lifting the bracket off the computer (2).

Figure 7-64 Removing the stand bracket

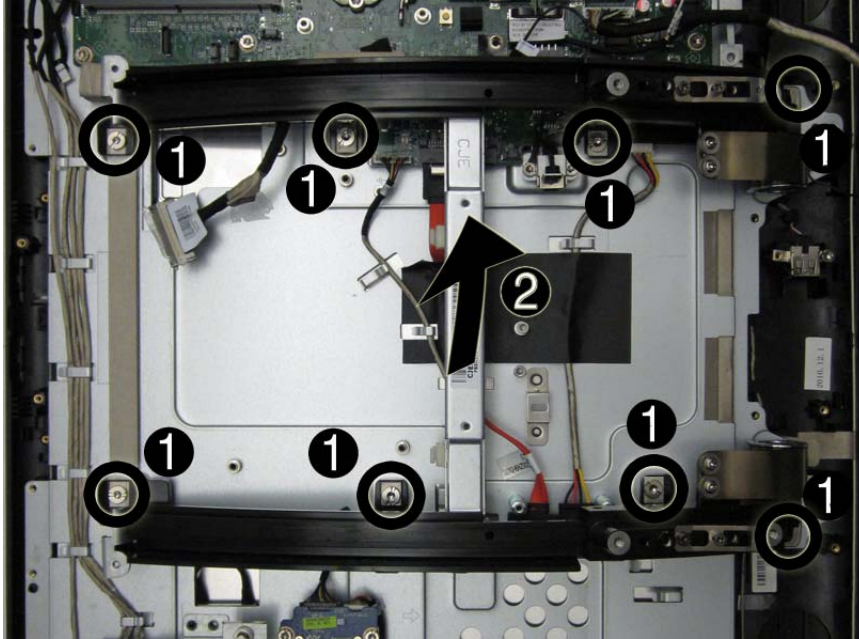

9. Remove the tape (1) that secures the cables to the computer.
10. Remove two screws (2) that secure the hard drive connector to the computer.
11. Disconnect the cables from the system board (3).

Figure 7-65 Removing the hard drive connector

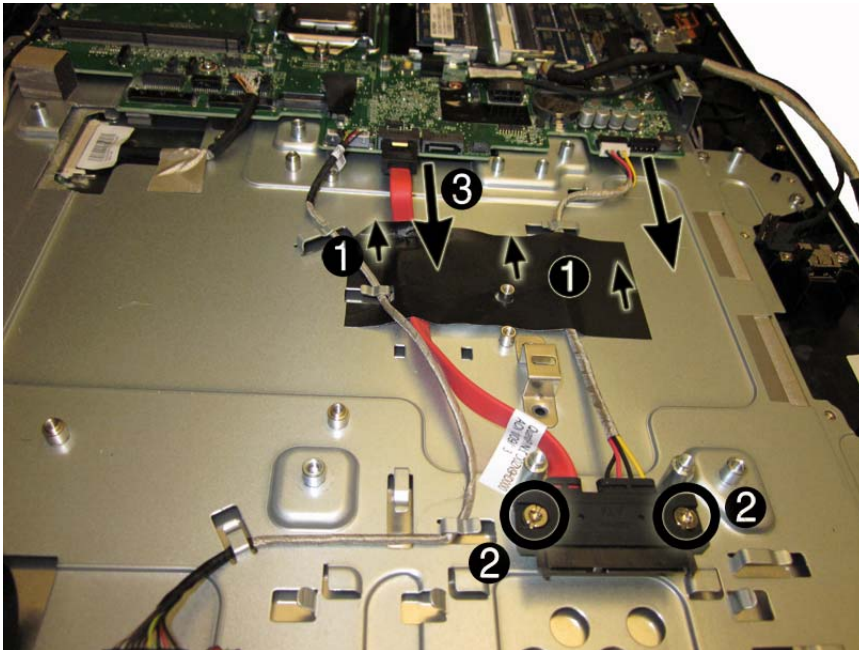

12. Remove the hard drive connector from the computer.

To install the hard drive connector, reverse the removal procedures.

Graphics board

| Description | Spare part number |
|-------------------------------------------|-------------------|
| GFX, 1 GB graphics card | 652164-001 |
| ATI MXM30 Viper 1-GB HD5570 graphics card | 628380-001 |

The graphics board is located near the top of the system board under the fan sink. You must remove the fan sink to remove the graphics board. The board is secured with two screws.

Figure 7-66 Graphics board location

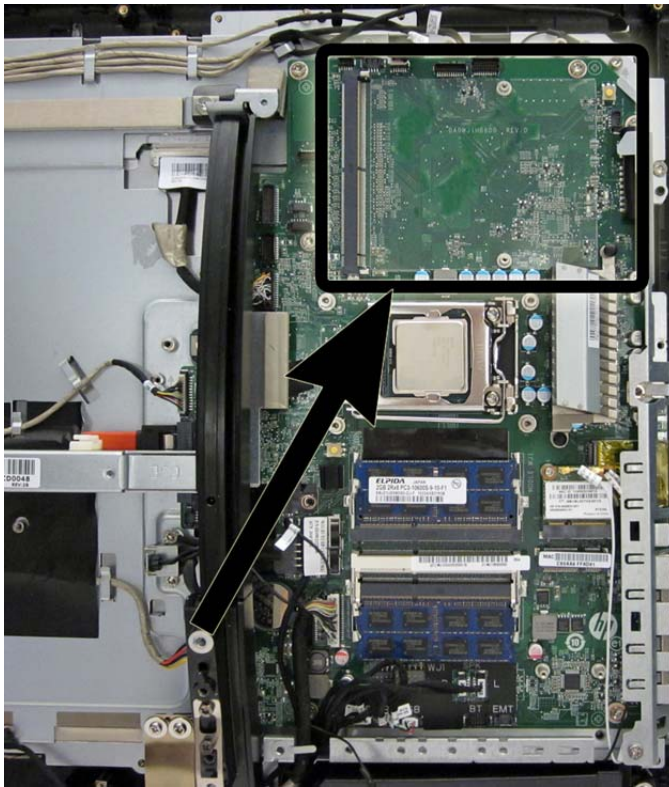

To remove the graphics board:

1. Prepare the computer for disassembly (see [Preparing to disassemble the computer on page 34](#)).
2. Remove the stand (see [Stand on page 35](#)).
3. Remove the right and left rear panels (see [Rear panels on page 47](#)).
4. Remove the left cap (see [Left cap on page 61](#)).
5. Remove the right cap (see [Right cap on page 67](#)).
6. Remove the rear logo cover (see [Rear logo cover on page 72](#)).
7. Remove the rear main frame (see [Main rear frame on page 75](#)).

8. Remove the system board shield (see [System board shield on page 77](#)).
9. Remove the fan sink (see [Fan sink \(Thermal module\) on page 85](#)).
10. Remove two screws (1) that secure the board to the computer.
11. Rotate the outer side of the board upward (2), and then remove it at an angle (3).

Figure 7-67 Removing the graphics board (board appearance may vary)



To install the graphics board, reverse the removal procedures.



NOTE: Graphics boards are designed with a notch to prevent incorrect insertion.

WLAN module and TV tuner module

The procedures for removing the WLAN module and the TV tuner module are very similar. The modules install into different slots located next to each other. This section shows removing the WLAN module, but you can use the same basic procedure to remove the TV tuner module. The number of antennas connected to the module may vary.

| Description | Spare part number |
|------------------------------------------------|-------------------|
| Intel Centrino® Advanced-N 6205 802.11a/b/g/n | 652165-001 |
| HP WLAN combo 802.11b/g/n + Bluetooth 2.1 card | 652279-001 |
| 802.11b/g/n | 654602-001 |
| HP TV tuner | 613990-001 |

The WLAN module is located near the middle of the system board. The module is secured with two screws and has two connected antennas.

Figure 7-68 WLAN module location

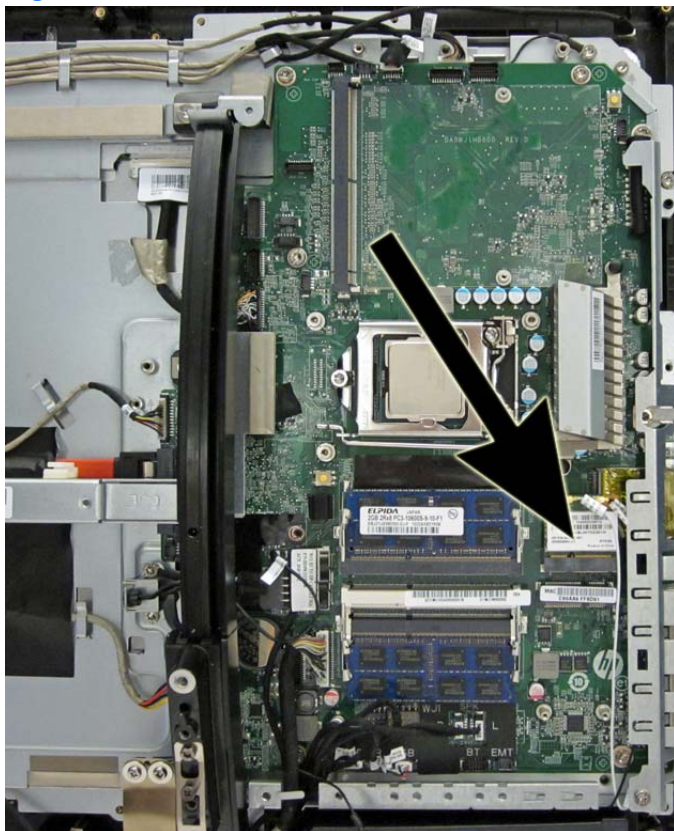

The TV tuner module is located toward the bottom of the system board near the memory sockets. The module is secured with two screws and has one antenna.

Figure 7-69 TV tuner location

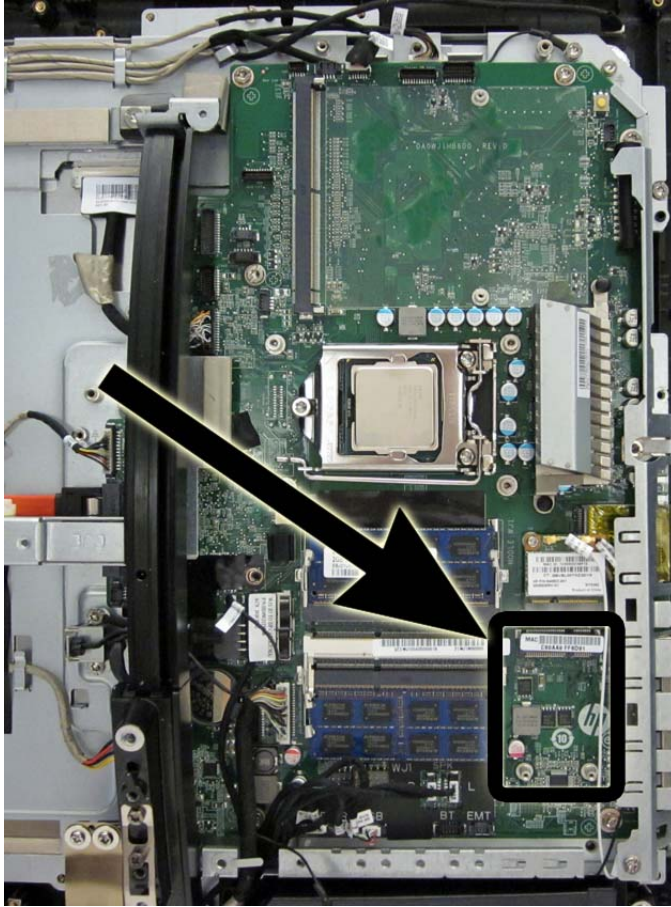

To remove the WLAN module:

1. Prepare the computer for disassembly (see [Preparing to disassemble the computer on page 34](#)).
2. Remove the stand (see [Stand on page 35](#)).
3. Remove the right and left rear panels (see [Rear panels on page 47](#)).
4. Remove the left cap (see [Left cap on page 61](#)).
5. Remove the right cap (see [Right cap on page 67](#)).
6. Remove the rear logo cover (see [Rear logo cover on page 72](#)).
7. Remove the rear main frame (see [Main rear frame on page 75](#)).
8. Remove the system board shield (see [System board shield on page 77](#)).
9. Disconnect the antenna cables from the module **(1)**. The number of antenna cables may vary.
10. Remove the screw **(2)** that secures the module to the computer.

11. Lift the module to a 45-degree angle, and then remove it from the system board (3).

Figure 7-70 Removing the WLAN module

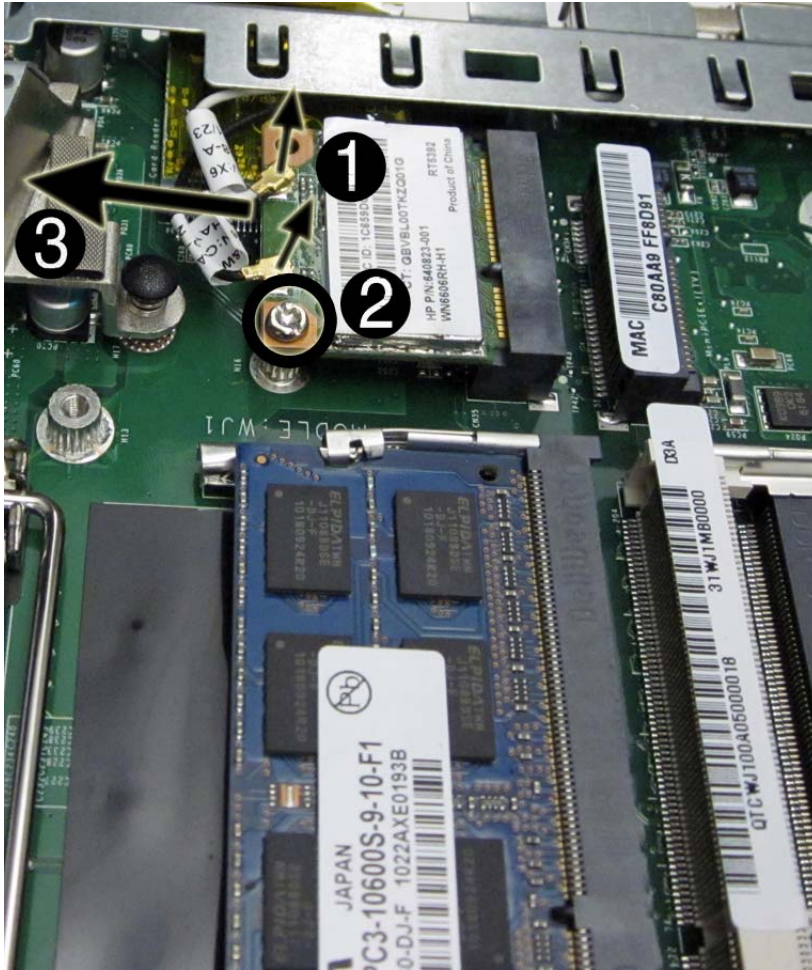

To install the WLAN module or TV tuner module, reverse the removal procedures.

 **NOTE:** WLAN modules and TV tuner modules are designed with a notch to prevent incorrect insertion.

System board

| Description | Spare part number |
|--------------|-------------------|
| System board | 658978-001 |

The system board is located on the right side of the computer (when viewed from the rear). It is secured with seven screws.

Figure 7-71 System board location

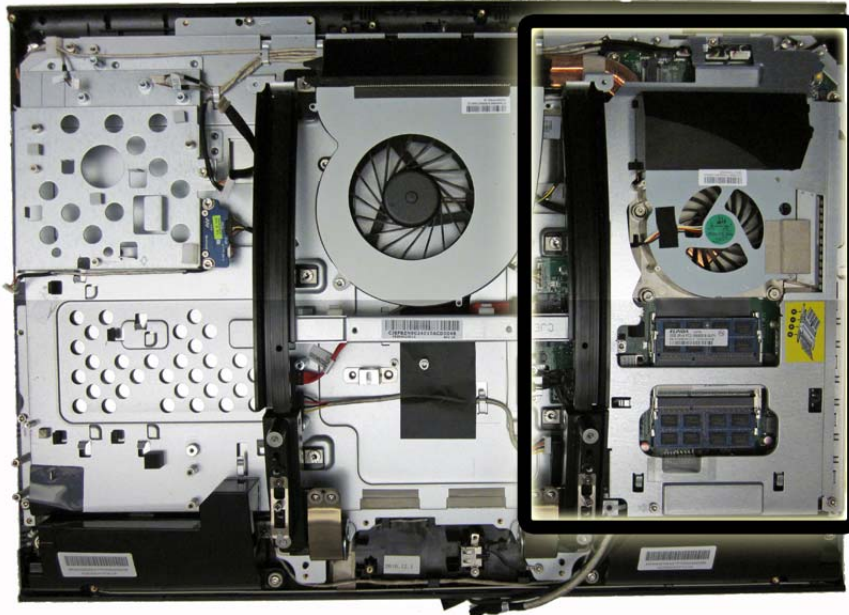

To remove the system board:

1. Prepare the computer for disassembly (see [Preparing to disassemble the computer on page 34](#)).
2. Remove the stand (see [Stand on page 35](#)).
3. Remove the right and left rear panels (see [Rear panels on page 47](#)).
4. Remove the left cap (see [Left cap on page 61](#)).
5. Remove the right cap (see [Right cap on page 67](#)).
6. Remove the rear logo cover (see [Rear logo cover on page 72](#)).
7. Remove the rear main frame (see [Main rear frame on page 75](#)).
8. Remove the system board shield (see [System board shield on page 77](#)).
9. Remove the fan (see [Fan on page 83](#)).
10. Remove the fan sink (see [Fan sink \(Thermal module\) on page 85](#)).
11. Remove the WLAN module and/or TV tuner module (see [WLAN module and TV tuner module on page 93](#)).
12. Remove the graphics board (see [Graphics board on page 91](#)).

13. Disconnect all cables from the system board, noting their location for reinstallation.
14. Remove the seven screws (circled in image) that secure the system board to the computer.
15. Lift the system board straight up and out of the computer.

Figure 7-72 Removing the system board

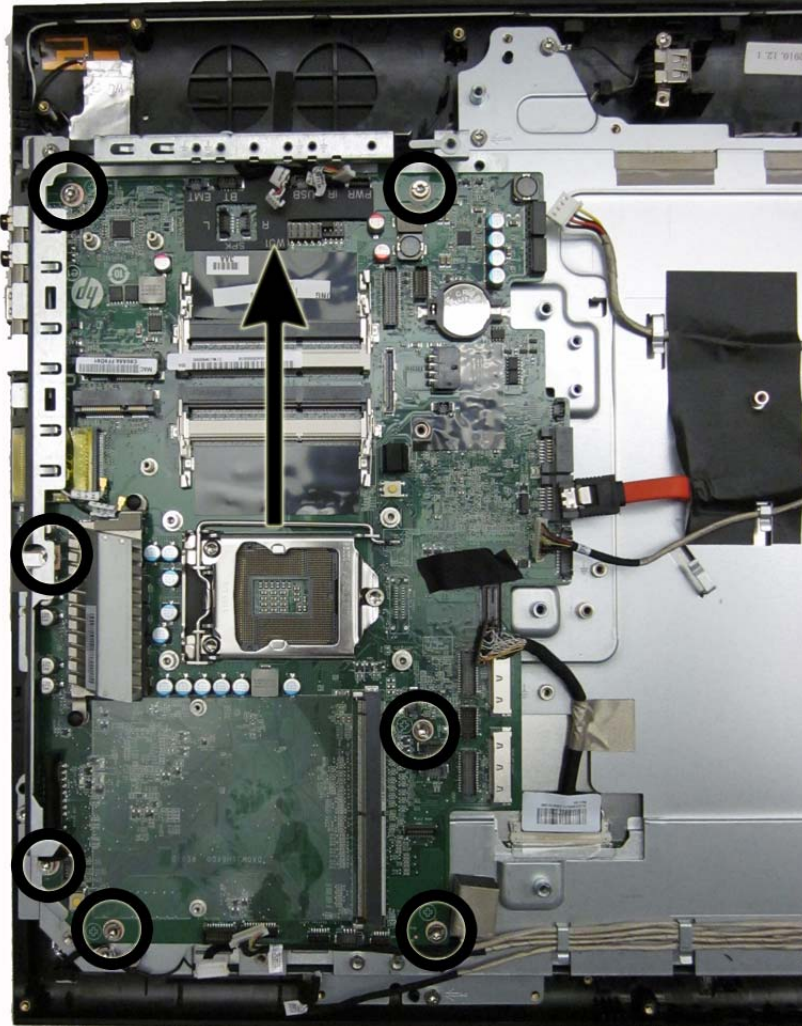

To install the system board, reverse the removal procedures.

Display panel

| Description | Spare part number |
|-----------------------------|-------------------|
| Display panel, 23-inch, ZBD | 658981-001 |
| Display, 23-inch, non-ZBD | 658979-001 |

The display panel is secured to the frame with 10 screws. The panel is secured to the front bezel with 6 screws.

To remove the display panel:

1. Prepare the computer for disassembly (see [Preparing to disassemble the computer on page 34](#)).
2. Remove the stand (see [Stand on page 35](#)).
3. Remove the right and left rear panels (see [Rear panels on page 47](#)).
4. Remove the left cap (see [Left cap on page 61](#)).
5. Remove the right cap (see [Right cap on page 67](#)).
6. Remove the rear logo cover (see [Rear logo cover on page 72](#)).
7. Remove the rear main frame (see [Main rear frame on page 75](#)).
8. Remove the system board shield (see [System board shield on page 77](#)).
9. Remove the fan (see [Fan on page 83](#)).
10. Remove the fan sink (see [Fan sink \(Thermal module\) on page 85](#)).
11. Remove the graphics board (see [Graphics board on page 91](#)).
12. Remove the WLAN module and/or TV tuner module (see [WLAN module and TV tuner module on page 93](#)).
13. Remove the system board (see [System board on page 96](#)).
14. Remove the 10 screws that secure the display panel to the computer. The number of screws per side is as follows:
 - Top: 2 screws
 - Bottom: 6 screws

- Left: 1 screw
- Right: 1 screw

Figure 7-73 Separating the display panel from the frame

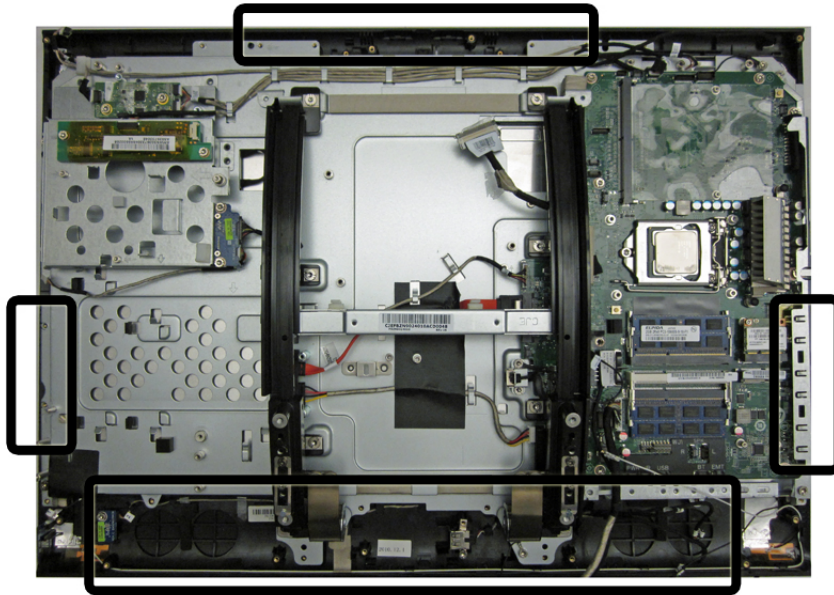

15. Separate the display panel from the computer.
16. Remove the six screws that secure the display panel to the front bezel (3 screws per side).

Figure 7-74 Separating the display panel from the front bezel



17. Lift the display panel from the front bezel.

To install a display panel, reverse the removal procedures.

G-sensor board

| Description | Spare part number |
|----------------|-------------------|
| G-sensor board | 658983-001 |
| G-sensor cable | 658984-001 |

The G-sensor board is mounted on the touchscreen glass. It senses when you tap on the glass, and it wakes the system if in standby mode. It is attached to the glass with adhesive.

Figure 7-75 G-sensor board location



To remove the G-sensor board:

1. Prepare the computer for disassembly (see [Preparing to disassemble the computer on page 34](#)).
2. Remove the stand (see [Stand on page 35](#)).
3. Remove the right and left rear panels (see [Rear panels on page 47](#)).
4. Remove the left cap (see [Left cap on page 61](#)).
5. Remove the right cap (see [Right cap on page 67](#)).
6. Remove the rear logo cover (see [Rear logo cover on page 72](#)).
7. Remove the rear main frame (see [Main rear frame on page 75](#)).
8. Remove the system board shield (see [System board shield on page 77](#)).
9. Remove the fan (see [Fan on page 83](#)).
10. Remove the fan sink (see [Fan sink \(Thermal module\) on page 85](#)).
11. Remove the graphics board (see [Graphics board on page 91](#)).
12. Remove the WLAN module and TV tuner module (see [WLAN module and TV tuner module on page 93](#)).
13. Remove the system board (see [System board on page 96](#)).
14. Remove the display (see [Display panel on page 98](#)).

15. Pry the board from the display.

Figure 7-76 Removing the G-sensor board



To install the G-sensor board, reverse the removal procedures.

A POST Error Messages

This appendix lists the error codes, error messages, and the various indicator light and audible sequences that you may encounter during Power-On Self-Test (POST) or computer restart, the probable source of the problem, and steps you can take to resolve the error condition.

POST Message Disabled suppresses most system messages during POST, such as memory count and non-error text messages. If a POST error occurs, the screen will display the error message. To manually switch to the POST Messages Enabled mode during POST, press any key (except **F10**, **F11**, or **F12**). The default mode is POST Message Disabled.

The speed at which the computer loads the operating system and the extent to which it is tested are determined by the POST mode selection.

Quick Boot is a fast startup process that does not run all of the system level tests, such as the memory test. Full Boot runs all of the ROM-based system tests and takes longer to complete.

Full Boot may also be enabled to run every 1 to 30 days on a regularly scheduled basis. To establish the schedule, reconfigure the computer to the Full Boot Every x Days mode, using Computer Setup.

POST Numeric Codes and Text Messages

This section covers those POST errors that have numeric codes associated with them. The section also includes some text messages that may be encountered during POST.



NOTE: The computer will beep once after a POST text message is displayed on the screen.

Table A-1 Numeric Codes and Text Messages

| Control panel message | Description | Recommended action |
|-----------------------------------------|-------------------------------------------------------------------------------------------------------------|-------------------------------------------------------------------------------------------------------------------------------------------------------------------------------------------------------------------------------------------------------------------------------------------------------------------------------------------------------------------------------------------------------------------------------------------------------------------------------------|
| 101-Option ROM Checksum Error | System ROM or expansion board option ROM checksum. | <ol style="list-style-type: none">1. Verify the correct ROM.2. Flash the ROM if needed.3. If an expansion board was recently added, remove it to see if the problem remains.4. Clear CMOS.5. If the message disappears, there may be a problem with the expansion card.6. Replace the system board. |
| 103-System Board Failure | DMA or timers. | <ol style="list-style-type: none">1. Clear CMOS.2. Remove expansion boards.3. Replace the system board. |
| 110-Out of Memory Space for Option ROMs | Recently added PCI expansion card contains an option ROM too large to download during POST. | <ol style="list-style-type: none">1. If a PCI expansion card was recently added, remove it to see if the problem remains.2. In Computer Setup, set Advanced > Device Options > NIC PXE Option ROM Download to DISABLE to prevent PXE option ROM for the internal NIC from being downloaded during POST to free more memory for an expansion card's option ROM. Internal PXE option ROM is used for booting from the NIC to a PXE server. |
| 162-System Options Not Set | Configuration incorrect. RTC (real-time clock) battery may need to be replaced. | Run Computer Setup and check the configuration in Advanced > Device Options . Reset the date and time under Control Panel . If the problem persists, replace the RTC battery. See the <i>Hardware Reference Guide</i> for instructions on installing a new battery, or contact an authorized dealer or reseller for RTC battery replacement. |
| 163-Time & Date Not Set | Invalid time or date in configuration memory. RTC (real-time clock) battery may need to be replaced. | Reset the date and time under Control Panel (Computer Setup can also be used). If the problem persists, replace the RTC battery. See the <i>Hardware Reference Guide</i> for instructions on installing a new battery, or contact an authorized dealer or reseller for RTC battery replacement. |

Table A-1 Numeric Codes and Text Messages (continued)

| Control panel message | Description | Recommended action |
|---------------------------------------------------------------------------|--------------------------------------------------------------------------------------------------------------------------------------------|-----------------------------------------------------------------------------------------------------------------------------------------------------------------------------------------------------------------------------------------------------------------------------------------------------------------|
| 164-MemorySize Error | Memory amount has changed since the last boot (memory added or removed). | Press the F1 key to save the memory changes. |
| 164-MemorySize Error | Memory configuration incorrect. | <ol style="list-style-type: none">1. Run Computer Setup or Windows utilities.2. Make sure the memory module(s) are installed properly.3. If third-party memory has been added, test using HP-only memory.4. Verify proper memory module type. |
| 201-Memory Error | RAM failure. | <ol style="list-style-type: none">1. Ensure memory modules are correctly installed.2. Verify proper memory module type.3. Remove and replace the identified faulty memory module(s).4. If the error persists after replacing memory modules, replace the system board. |
| 213-Incompatible Memory Module in Memory Socket(s) X, X, ... | A memory module in memory socket identified in the error message is missing critical SPD information, or is incompatible with the chipset. | <ol style="list-style-type: none">1. Verify proper memory module type.2. Try another memory socket.3. Replace DIMM with a module conforming to the SPD standard. |
| 214-DIMM Configuration Warning | Populated DIMM Configuration is not optimized. | Rearrange the DIMMs so that each channel has the same amount of memory. |
| 219-ECC Memory Module Detected ECC Modules not supported on this Platform | Recently added memory module(s) support ECC memory error correction. | <ol style="list-style-type: none">1. If additional memory was recently added, remove it to see if the problem remains.2. Check product documentation for memory support information. |
| 301-Keyboard Error | Keyboard failure. | <ol style="list-style-type: none">1. Reconnect keyboard with computer turned off.2. Check connector for bent or missing pins.3. Ensure that none of the keys are depressed.4. Replace keyboard. |
| 303-Keyboard Controller Error | I/O board keyboard controller. | <ol style="list-style-type: none">1. Reconnect keyboard with computer turned off.2. Replace the system board. |

Table A-1 Numeric Codes and Text Messages (continued)

| Control panel message | Description | Recommended action |
|---------------------------------------------------------------|----------------------------------------------------------------------------------------------------------------------------|------------------------------------------------------------------------------------------------------------------------------------------------------------------------------------------------------------------------------------------------------------------------------------------------------------------------------------------------------------------------------------------------------------------------|
| 304-Keyboard or System Unit Error | Keyboard failure. | <ol style="list-style-type: none"> 1. Reconnect the keyboard with computer turned off. 2. Ensure that none of the keys are depressed. 3. Replace the keyboard. 4. Replace the system board. |
| 510-Flash Screen Image Corrupted | Flash Screen image has errors. | Reflash the system ROM with the latest BIOS image. |
| 511-CPU Fan not Detected | CPU fan is not connected or may have malfunctioned. | <ol style="list-style-type: none"> 1. Reseat CPU fan. 2. Reseat fan cable. 3. Replace CPU fan. |
| 512-Rear Chassis Fan not Detected | Rear chassis fan is not connected or may have malfunctioned. | <ol style="list-style-type: none"> 1. Reseat rear chassis fan. 2. Reseat fan cable. 3. Replace rear chassis fan. |
| 513-Front Chassis fan not detected | Front chassis fan is not connected or may have malfunctioned. | <ol style="list-style-type: none"> 1. Reseat front chassis fan. 2. Reseat fan cable. 3. Replace front chassis fan. |
| 912-Computer Cover Has Been Removed Since Last System Startup | Computer cover was removed since last system startup. | No action required. |
| 917-Front Audio Not Connected | Front audio harness has been detached or unseated from motherboard. | Reconnect or replace front audio harness. |
| 921-Device in PCI Express slot failed to initialize | There is an incompatibility/problem with this device and the system or PCI Express Link could not be retrained to an x1. | Try rebooting the system. If the error reoccurs, the device may not work with this system |
| 1720-SMART Hard Drive Detects Imminent Failure | Hard drive is about to fail. (Some hard drives have a hard drive firmware patch that will fix an erroneous error message.) | <ol style="list-style-type: none"> 1. Determine if hard drive is giving correct error message. Enter Computer Setup and run the Drive Protection System test under Storage > DPS Self-test. 2. Apply hard drive firmware patch if applicable. (Available at http://www.hp.com/support.) 3. Back up contents and replace hard drive. |
| 1801-Microcode Patch Error | Processor is not supported by ROM BIOS. | <ol style="list-style-type: none"> 1. Upgrade BIOS to proper version. 2. Change the processor. |
| 1802-Processor Not Supported | Recently installed processor is not supported by the system. | Install a processor supported by your system. |

Table A-1 Numeric Codes and Text Messages (continued)

| Control panel message | Description | Recommended action |
|------------------------------------------------|-----------------------------------------------------------------------------------------------------------|------------------------------------------------------------------------------------------------------------------------------------------------------------------------------------------------------------------------------------------------------------------------------------------------------------------------------------------------------------------------------------------------------------------------------------------------------------------------------------------------------------------------------------------------------------------------------------------------------------------------------------------------------------|
| 1805-Ambient Temperature Previously Over Limit | This system was placed in a low power state to prevent damage due to excessive environmental temperature. | <p>Make sure the system meets the HP enclosure guidelines as listed in the QuickSpecs, including the following:</p> <ol style="list-style-type: none">1. Clean the air vents on the front, back, or any other vented side of the computer.2. Ensure that there is a 10.2 cm (4 in) clearance on all vented sides of the computer to permit the required airflow.3. Ensure that computers are not so near each other that they are subject to each other's re-circulated or preheated air.4. If the computer is within an enclosure, ensure that there is proper intake and exhaust ventilation for the enclosure. |
| 2200-PMM Allocation Error during MEBx Download | Memory error during POST execution of the Management Engine (ME) BIOS Extensions option ROM. | <ol style="list-style-type: none">1. Reboot the computer.2. Unplug the power cord, re-seat the memory modules, and reboot the computer.3. If the memory configuration was recently changed, unplug the computer, restore the original memory configuration, and reboot the computer.4. If the error persists, replace the system board. |
| 2201-MEBx Module did not checksum correctly | Memory error during POST execution of the Management Engine (ME) BIOS Extensions option ROM. | <ol style="list-style-type: none">1. Reboot the computer.2. Unplug the power cord, re-seat the memory modules, and reboot the computer.3. If the memory configuration was recently changed, unplug the power cord, restore the original memory configuration, and reboot the computer.4. If the error persists, replace the system board. |

Table A-1 Numeric Codes and Text Messages (continued)

| Control panel message | Description | Recommended action |
|----------------------------------------------------------------|----------------------------------------------------------------------------------------------------------------------|------------------------------------------------------------------------------------------------------------------------------------------------------------------------------------------------------------------------------------------------------------------------------------------------------------------------------------------------------------------------------------|
| 2202-PMM Deallocation Error during MEBx cleanup | Memory error during POST execution of the Management Engine (ME) BIOS Extensions option ROM. | <ol style="list-style-type: none">1. Reboot the computer.2. Unplug the power cord, re-seat the memory modules, and reboot the computer.3. If the memory configuration was recently changed, unplug the power cord, restore the original memory configuration, and reboot the computer.4. If the error persists, replace the system board. |
| 2211-Memory not configured correctly for proper MEBx execution | SODIMM1 is not installed. | Make sure there is a memory module in the SODIMM1 socket and that it is properly seated. |
| 2212-USB Key Provisioning failure writing to device | USB device used for USB key provisioning will not allow BIOS to update provision file properly. | <ol style="list-style-type: none">1. Try a different USB key device for provisioning.2. If the error persists, update to the latest BIOS version and ME firmware version.3. If the error still persists, replace the system board. |
| 2217-ME Firmware Version request failure | ME firmware is not properly responding to BIOS query for version information. | <ol style="list-style-type: none">1. Reboot the computer.2. If the error persists, update to the latest BIOS version and ME firmware version.3. If the error still persists, replace the system board. |
| 2218-ME Firmware Version should be updated | ME firmware must be updated to match current functionality contained in the system BIOS. | <ol style="list-style-type: none">1. Update to the latest ME firmware version.2. If the error persists and system BIOS has been recently updated, restore previous system BIOS version.3. If the error still persists, replace the system board. |
| 2219-USB Key Provisioning file has invalid header identifier | Provisioning file contained on the USB key has been corrupted or is not a valid version for the current ME firmware. | <ol style="list-style-type: none">1. Recreate the provisioning file using third party management console software.2. If the error persists and system BIOS has been recently updated, restore previous system BIOS version. Otherwise, update the ME firmware version.3. If the error still persists, replace the system board. |

Table A-1 Numeric Codes and Text Messages (continued)

| Control panel message | Description | Recommended action |
|-----------------------------------------------------|--------------------------------------------------------------------------------------------------------------------------------------------------------------------------------------------------------------------------------------------------------------|--------------------------------------------------------------------------------------------------------------------------------------------------------------------------------------------------------------------------------------------------------------------------------------------------------|
| 2220-USB Key Provisioning file has mismatch version | Provisioning file contained on the USB key is not a valid version for the current ME firmware. | <ol style="list-style-type: none">1. Reboot the computer.2. If the error persists and system BIOS has been recently updated, restore previous system BIOS version. Otherwise, update the ME firmware version.3. If the error still persists, replace the system board. |
| 2230-General error during MEBx execution | Error occurred during MEBx execution which fails into the "General" grouping. Status information displayed along with the error provides further clarity into the failure. MEBx handles transference of information between the system BIOS and ME firmware. | <ol style="list-style-type: none">1. Reboot the computer.2. If the error persists, update to the latest BIOS version and ME firmware version.3. If the error still persists, replace the system board. |
| 2231-ME error during MEBx execution | Error occurred during MEBx execution which fails into "ME" grouping. | <ol style="list-style-type: none">1. Reboot the computer.2. If the error persists, update to the latest BIOS version and ME firmware version.3. If the error still persists, replace the system board. |
| 2232-AMT error during MEBx execution | Error occurred during MEBx execution which fails into "AMT" grouping. | <ol style="list-style-type: none">1. Reboot the computer.2. If the error persists, update to the latest BIOS version and ME firmware version.3. If the error still persists, replace the system board. |
| 2233-HECI error during MEBx execution | Error occurred during MEBx execution which fails into "MEI or HECI" grouping. | <ol style="list-style-type: none">1. Reboot the computer.2. If the error persists, update to the latest BIOS version and ME firmware version.3. If the error still persists, replace the system board. |
| Invalid Electronic Serial Number | Electronic serial number is missing. | Enter the correct serial number in Computer Setup. |

Table A-1 Numeric Codes and Text Messages (continued)

| Control panel message | Description | Recommended action |
|-----------------------------------------------------|---------------------------------------------------------------|------------------------------------------------------------------------------------------------------------------------------------------------------------------------------------------------------------------------------------------|
| Network Server Mode Active and No Keyboard Attached | Keyboard failure while Network Server Mode enabled. | <ol style="list-style-type: none">1. Reconnect keyboard with computer turned off.2. Check connector for bent or missing pins.3. Ensure that none of the keys are depressed.4. Replace keyboard. |
| Parity Check 2 | Parity RAM failure or a PCI/PCIe device is asserting a SERR#. | Run Computer Setup and Diagnostic utilities. To disable a PCI/PCIe device from asserting a SERR#, run the Computer Setup utility and select Advanced > Bus Options > SERR# Generation > Disable . |

Interpreting POST Diagnostic Front Panel LEDs and Audible Codes

This section covers the front panel LED codes as well as the audible codes that may occur before or during POST that do not necessarily have an error code or text message associated with them.

 **WARNING!** When the computer is plugged into an AC power source, voltage is always applied to the system board. To reduce the risk of personal injury from electrical shock and/or hot surfaces, be sure to disconnect the power cord from the wall outlet and allow the internal system components to cool before touching.

 **NOTE:** If you see flashing LEDs on a PS/2 keyboard, look for flashing LEDs on the front panel of the computer and refer to the following table to determine the front panel LED codes.

Recommended actions in the following table are listed in the order in which they should be performed.

Not all diagnostic lights and audible codes are available on all models.

Table A-2 Diagnostic Front Panel LEDs and Audible Codes

| Activity | Beeps | Possible Cause | Recommended Action |
|-------------------------------------------------------------------------------------------------------------------------------------------------------------------|-------|--------------------------------------------------------------------------------------------------------------------------------------|---------------------------------------------------------------------------------------------------------------------------------------------------------------------------------------------------------------------------------------------------------------------------------------------------------------------------------------------------------------------------------------------------------------------------------------------------------------------------------------------------------------------------------------------------------------------------------------------------------------------------------------------------------------------------------------------------------------|
| Green Power LED On. | None | Computer on. | None |
| Green Power LED flashes every two seconds. | None | Computer in Suspend to RAM mode (some models only) or normal Suspend mode. | None required. Press any key or move the mouse to wake the computer. |
| Red Power LED flashes two times, once every second, followed by a two second pause. Beeps stop after fifth iteration but LEDs continue until problem is solved. | 2 | Thermal protection activated: Air flow is restricted, a fan may not be functioning, or the heatsink is not properly attached. | <ol style="list-style-type: none"> 1. Clean the air vents on the front, back, or any other vented side of the computer. 2. Ensure that there is a 10.2 cm (4 in) clearance on all vented sides of the computer to permit the required airflow. 3. Ensure that computers are not so near each other that they are subject to each other's re-circulated or preheated air. 4. If the computer is within an enclosure, ensure that there is proper intake and exhaust ventilation for the enclosure. 5. If a message appears on the screen indicating that a fan is not working, replace the fan. 6. Ensure that the heat sink is properly attached. |
| Red Power LED flashes three times, once every second, followed by a two second pause. Beeps stop after fifth iteration but LEDs continue until problem is solved. | 3 | Processor not installed (not an indicator of bad processor). | <ol style="list-style-type: none"> 1. Check to see that the processor is present. 2. Reseat the processor. |

Table A-2 Diagnostic Front Panel LEDs and Audible Codes (continued)

| Activity | Beeps | Possible Cause | Recommended Action |
|-------------------------------------------------------------------------------------------------------------------------------------------------------------------|-------|-------------------------------------------------------------|---------------------------------------------------------------------------------------------------------------------------------------------------------------------------------------------------------------------------------------------------------------------------------------------------------------------------------------------------------------------------------------------------------------------------------------------------------------------------------------------------------------------------------------------------------------------------------------------------------------------------------------------------------------------------------------------|
| Red Power LED flashes four times, once every second, followed by a two second pause. Beeps stop after fifth iteration but LEDs continue until problem is solved. | 4 | Power failure (power supply is overloaded). | <ol style="list-style-type: none">1. Open the hood and ensure the 4 or 6-wire power supply cable is seated into the connector on the system board.2. Check if a device is causing the problem by removing ALL attached devices (such as hard, diskette, or optical drives, and expansion cards). Power on the system. If the system enters the POST, then power off and replace one device at a time and repeat this procedure until failure occurs. Replace the device that is causing the failure. Continue adding devices one at a time to ensure all devices are functioning properly.3. Replace the power supply.4. Replace the system board. |
| Red Power LED flashes five times, once every second, followed by a two second pause. Beeps stop after fifth iteration but LEDs continue until problem is solved. | 5 | Pre-video memory error. | <p>CAUTION: To avoid damage to the DIMMs or the system board, you must unplug the computer power cord before attempting to reseat, install, or remove a DIMM module.</p> <ol style="list-style-type: none">1. Reseat DIMMs.2. Replace DIMMs one at a time to isolate the faulty module.3. Replace third-party memory with HP memory.4. Replace the system board. |
| Red Power LED flashes six times, once every second, followed by a two second pause. Beeps stop after fifth iteration but LEDs continue until problem is solved. | 6 | Pre-video graphics error. | <p>For systems with a graphics card:</p> <ol style="list-style-type: none">1. Reseat the graphics card.2. Replace the graphics card.3. Replace the system board. <p>For systems with integrated graphics, replace the system board.</p> |
| Red Power LED flashes seven times, once every second, followed by a two second pause. Beeps stop after fifth iteration but LEDs continue until problem is solved. | 7 | System board failure (ROM detected failure prior to video). | Replace the system board. |
| Red Power LED flashes eight times, once every second, followed by a two second pause. Beeps stop after fifth iteration but LEDs continue until problem is solved. | 8 | Invalid ROM based on bad checksum. | <ol style="list-style-type: none">1. Reflash the system ROM with the latest BIOS image.2. Replace the system board. |

Table A-2 Diagnostic Front Panel LEDs and Audible Codes (continued)

| Activity | Beeps | Possible Cause | Recommended Action |
|--------------------------------------------------------------------------------------------------------------------------------------------------------------------|-------|-------------------------------------------------------------------------------------|---------------------------------------------------------------------------------------------------------------------------------------------------------------------------------------------------------------------------------------------------------------------------------------------------------------------------------------------------------------------------------------------------------------------------------------------------------------------------------------------------------------------------------------------------------------------------------------------------------------------------------------------------------------------------------------------------------------------------------------------------------------------------------------------------------------------------------------------------------------------------------------------------------------------------------------------------------------------------------------------------------------------------------------------------|
| Red Power LED flashes nine times, once every second, followed by a two second pause. Beeps stop after fifth iteration but LEDs continue until problem is solved. | 9 | System powers on but is unable to boot. | <ol style="list-style-type: none">1. Unplug the AC power cord from the computer, wait 30 seconds, then plug the power cord back in to the computer.2. Replace the system board.3. Replace the processor. |
| Red Power LED flashes ten times, once every second, followed by a two second pause. Beeps stop after fifth iteration but LEDs continue until problem is solved. | 10 | Bad option card. | <ol style="list-style-type: none">1. Check each option card by removing the card (one at a time if multiple cards), then power on the system to see if fault goes away.2. Once a bad card is identified, remove and replace the bad option card.3. Replace the system board. |
| Red Power LED flashes eleven times, once every second, followed by a two second pause. Beeps stop after fifth iteration but LEDs continue until problem is solved. | 11 | The current processor does not support a feature previously enabled on this system. | <ol style="list-style-type: none">1. Install a TXT capable processor.2. Disable TXT in the Computer Setup (F10) utility.3. Reinstall the original processor. |
| System does not power on and LEDs are not flashing. | None | System unable to power on. | <p>Press and hold the power button for less than 4 seconds. If the hard drive LED turns green, the power button is working correctly and the system board needs to be replaced.</p> <p>OR</p> <p>Press and hold the power button for less than 4 seconds. If the hard drive LED does not turn on green then:</p> <ol style="list-style-type: none">1. Check that the unit is plugged into a working AC outlet.2. Open hood and check that the power button harness is properly connected to the system board.3. Check that both power supply cables are properly connected to the system board.4. Check to see if the 5V_aux light on the system board is turned on. If it is turned on, then replace the power button harness. If the problem persists, replace the system board.5. If the 5V_aux light on the system board is not turned on, remove the expansion cards one at a time until the 5V_aux light on the system board turns on. If the problem persists, replace the power supply. |

B Troubleshooting Without Diagnostics

This chapter provides information on how to identify and correct minor problems, such as diskette drive, hard drive, optical drive, graphics, audio, memory, and software problems. If you encounter problems with the computer, refer to the tables in this chapter for probable causes and recommended solutions.



NOTE: For information on specific error messages that may appear on the screen during Power-On Self-Test (POST) at startup, refer to Appendix A, [POST Error Messages on page 102](#).

Safety and Comfort



WARNING! Misuse of the computer or failure to establish a safe and comfortable work environment may result in discomfort or serious injury. Refer to the *Safety & Comfort Guide* at <http://www.hp.com/ergo> for more information on choosing a workspace and creating a safe and comfortable work environment. For more information, refer to the *Safety & Regulatory Information* guide.

Solving General Problems

You may be able to easily resolve the general problems described in this section. If a problem persists and you are unable to resolve it yourself or if you feel uncomfortable about performing the operation, contact an authorized dealer or reseller.

⚠ WARNING! When the computer is plugged into an AC power source, voltage is always applied to the system board. To reduce the risk of personal injury from electrical shock and/or hot surfaces, be sure to disconnect the power cord from the wall outlet and allow the internal system components to cool before touching.

Table B-1 Solving General Problems

Computer appears locked up and will not turn off when the power button is pressed.

| Cause | Solution |
|---------------------------------------------------------|-------------------------------------------------------------------------------------------------------------------------------------------------------------------------------------------------------------|
| Software control of the power switch is not functional. | <ol style="list-style-type: none">1. Press and hold the power button for at least four seconds until the computer turns off.2. Disconnect the power cord from the electrical outlet. |

Computer will not respond to USB keyboard or mouse.

| Cause | Solution |
|-------------------------------------|--------------------------------------------------------------------------------------------------------------------------------------------------------------------------------------------------------------------------------------------------------------------------------------------------|
| Computer is in standby mode. | To resume from standby mode, press the power button or press any key. CAUTION: When attempting to resume from standby mode, do not hold down the power button for more than four seconds. Otherwise, the computer will shut down and you will lose any unsaved data. |
| System has locked up. | Restart computer. |

Computer date and time display is incorrect.

| Cause | Solution |
|--------------------------------------------------------------------------------------------------------------------------------------------------------------|-----------------------------------------------------------------------------------------------------------------------------------------------------------------------------------------------------------------------------------------------------------------------------------------------------------------------------------------------|
| RTC (real-time clock) battery may need to be replaced. NOTE: Connecting the computer to a live AC outlet prolongs the life of the RTC battery. | First, reset the date and time under Control Panel (Computer Setup can also be used to update the RTC date and time). If the problem persists, replace the RTC battery. See the Removal and Replacement section for instructions on installing a new battery, or contact an authorized dealer or reseller for RTC battery replacement. |

Cursor will not move using the **arrow keys on the keypad.**

| Cause | Solution |
|------------------------------------|--------------------------------------------------------------------------------------------------------------------------------------------------------------------------------------|
| The Num Lock key may be on. | Press the Num Lock key. The Num Lock light should not be on if you want to use the arrow keys. The Num Lock key can be disabled (or enabled) in Computer Setup. |

There is no sound or sound volume is too low.

| Cause | Solution |
|----------------------------------------|-----------------------------------------------------------------------------------------------------------------------------------------------------------------------------------------------------------------------------------------------------------------------------------------------------------------------------------------------------------------------------------------------------------------------------------------------------------------------------------|
| System volume may be set low or muted. | <ol style="list-style-type: none">1. Check the F10 BIOS settings to make sure the internal system speaker is not muted (this setting does not affect the external speakers).2. Make sure the external speakers are properly connected and powered on and that the speakers' volume control is set correctly.3. Use the system volume control available in the operating system to make sure the speakers are not muted or to increase the volume. |

Poor performance is experienced.

| Cause | Solution |
|---------------------------------------------------------------------------------------|-------------------------------------------------------------------------------------------------------------------------------------------------------------------------------------------------------------------------------------------------------------------------------------------------------------------------------------------------------------------------------------------------------------------------------------------------------------------------------------------------------------------------------------------------------------------------------------------------------------------------|
| Processor is hot. | <ol style="list-style-type: none">1. Make sure airflow to the computer is not blocked. Leave a 10.2-cm (4-inch) clearance on all vented sides of the computer and above the monitor to permit the required airflow.2. Make sure fans are connected and working properly (some fans only operate when needed).3. Make sure the processor heat sink is installed properly. |
| Hard drive is full. | Transfer data from the hard drive to create more space on the hard drive. |
| Low on memory. | Add more memory. |
| Hard drive fragmented. | Defragment hard drive. |
| Program previously accessed did not release reserved memory back to the system. | Restart the computer. |
| Virus resident on the hard drive. | Run virus protection program. |
| Too many applications running. | <ol style="list-style-type: none">1. Close unnecessary applications to free up memory.2. Add more memory. Some applications run in the background and can be closed by right-clicking on their corresponding icons in the task tray. To prevent these applications from launching at startup, go to Start > Run (Windows XP) or Start > All Programs > Accessories > Run (Windows Vista and Windows 7) and type <code>msconfig</code>. On the Startup tab of the System Configuration Utility, clear applications that you do not want to launch automatically. |
| Some software applications, especially games, are stressful on the graphics subsystem | <ol style="list-style-type: none">1. Lower the display resolution for the current application or consult the documentation that came with the application for suggestions on how to improve performance by adjusting parameters in the application.2. Add more memory.3. Upgrade the graphics solution. |
| Cause unknown. | Restart the computer. |

Computer powered off automatically and the Power LED flashes Red two times, once every second, followed by a two second pause, and the computer beeps two times. (Beeps stop after fifth iteration but LEDs continue flashing).

| Cause | Solution |
|---------------------------------------------------------------------------------------------------------------------------------------------------|---------------------------------------------------------------------------------------------------------------------------------------------------------------------------------------------------------------------------------------------------------------------------------------------------------------------------------------------------------------------------------------------------------------------------------------|
| Processor thermal protection activated: A fan may be blocked or not turning. OR The heat sink is not properly attached to the processor. | <ol style="list-style-type: none">1. Ensure that the computer air vents are not blocked and the processor cooling fan is running.2. Open hood, press power button, and see if the processor fan spins. If the processor fan is not spinning, make sure the fan's cable is plugged onto the system board header.3. If fan is plugged in, but is not spinning, then replace the heat sink/fan assembly. |

System does not power on and the LEDs on the front of the computer are not flashing.

| Cause | Solution |
|----------------------------|--------------------------------------------------------------------------------------------------------------------------------------------------------------------------------------------------------------------------------------------------------------------------------------------------------------------------------------------------------------------------------------------------------------------------------------------------------------------------------------------------------------------------------------------------------------------------------------------------------------------------------------------------------------------------------------------------------------------------------------------------------------------------------------------------------------------------------------------------------------------------------------------------------------------------------------------------------------------------------------------------------------------------------------------------------------------------------------------------|
| System unable to power on. | <p>Press and hold the power button for less than 4 seconds. If the hard drive LED turns green, then:</p> <ol style="list-style-type: none">1. Check that the voltage selector, located on the rear of the power supply on some models, is set to the appropriate voltage. Proper voltage setting depends on your region.2. Replace the system board. <p>OR</p> <p>Press and hold the power button for less than 4 seconds. If the hard drive LED does not turn on green then:</p> <ol style="list-style-type: none">1. Check that the unit is plugged into a working AC outlet.2. Open computer and check that the power button board cable is properly connected to the system board.3. Check that power supply cables are properly connected to the system board.4. Check to see if the 5V_aux light on the system board is turned on. If it is turned on, then replace the power button board.5. If the 5V_aux light on the system board is off, then replace the power supply.6. Replace the system board. |

Solving Power Problems

Common causes and solutions for power problems are listed in the following table.

Table B-2 Solving Power Problems

Computer powered off automatically and the Power LED flashes red two times, once every second, followed by a two second pause, and the computer beeps two times. (Beeps stop after fifth iteration but LEDs continue flashing.)

| Cause | Solution |
|---------------------------------------------------------------------------------------------------------------------------------------------------|---------------------------------------------------------------------------------------------------------------------------------------------------------------------------------------------------------------------------------------------------------------------------------------------------------------------------------------------------------------------------------------------------------------------------------------|
| Processor thermal protection activated: A fan may be blocked or not turning. OR The heat sink is not properly attached to the processor. | <ol style="list-style-type: none">1. Ensure that the computer air vents are not blocked and the processor cooling fan is running.2. Open hood, press power button, and see if the processor fan spins. If the processor fan is not spinning, make sure the fan's cable is plugged onto the system board header.3. If fan is plugged in, but is not spinning, then replace the heat sink/fan assembly. |

Power LED flashes red four times, once every second, followed by a two second pause, and the computer beeps four times. (Beeps stop after fifth iteration but LEDs continue flashing.)

| Cause | Solution |
|---------------------------------------------|--------------------------------------------------------------------------------------------------------------------------------------------------------------------------------------------------------------------------------------------------------------------------------------------------------------------------------------------------------------------------------------------------------------------------------------------------------------------------------------------------------------------------------------------------------------------|
| Power failure (power supply is overloaded). | <ol style="list-style-type: none">1. Check if a device is causing the problem by removing ALL attached devices (such as hard, diskette, or optical drives, and expansion cards). Power on the system. If the system enters the POST, then power off and replace one device at a time and repeat this procedure until failure occurs. Replace the device that is causing the failure. Continue adding devices one at a time to ensure all devices are functioning properly.2. Replace the power supply.3. Replace the system board. |

Solving Diskette Problems

Common causes and solutions for diskette problems are listed in the following table.

 **NOTE:** The computer does not support internal diskette drives. Only USB diskette drives are supported.

 **NOTE:** You may need to reconfigure the computer when you add or remove hardware, such as an additional diskette drive. See [Solving Hardware Installation Problems on page 134](#) for instructions.

Table B-3 Solving Diskette Problems

Diskette drive light stays on.

| Cause | Solution |
|----------------------------------------|----------------------------------------------------------------------------------------------------------------------------------------------------------------------------------------------------------------------------------------------------------------------------------------------------------------------------------------------------------------------------------------------------------------------------------------------------|
| Diskette is damaged. | In Microsoft Windows XP, right-click Start , click Explore , and select a drive. Select File > Properties > Tools . Under Error-checking click Check Now . In Microsoft Windows Vista and Windows 7, right-click Start , click Explore , and right-click on a drive. Select Properties then select the Tools tab. Under Error-checking click Check Now . |
| Diskette is incorrectly inserted. | Remove diskette and reinsert. |
| Drive cable is not properly connected. | Reconnect drive cable. Ensure that all four pins on the diskette power cable are connected to the drive. |

Drive not found.

| Cause | Solution |
|-----------------------------------------------|-------------------------------------------------------------------------------------------------------------------------------------------------|
| Cable is loose. | Reseat diskette drive data and power cable. |
| Removable drive is not seated properly. | Reseat the drive. |
| The device has been hidden in Computer Setup. | Run the Computer Setup utility and ensure Device Available is selected for the Legacy Diskette in Security > Device Security . |

Diskette drive cannot write to a diskette.

| Cause | Solution |
|------------------------------|----------------------------------------------------------------------------------------------------------------------------------------------------------------------------------------------------------------------------------------------------------------------------------------------------------|
| Diskette is not formatted. | Format the diskette. <ol style="list-style-type: none">1. From Windows Explorer select the disk (A) drive.2. Right-click the drive letter and select Format.3. Select the desired options, and click Start to begin formatting the diskette. |
| Diskette is write-protected. | Use another diskette or remove the write protection. |
| Writing to the wrong drive. | Check the drive letter in the path statement. |

Table B-3 Solving Diskette Problems (continued)

| Diskette drive cannot write to a diskette. | |
|---------------------------------------------------|--------------------------------------------------------------------------------------------------------------------------|
| Cause | Solution |
| Not enough space is left on the diskette. | <ol style="list-style-type: none">1. Use another diskette.2. Delete unneeded files from diskette. |
| Diskette is damaged. | Replace the damaged disk. |

| Cannot format diskette. | |
|--------------------------------------------------------|----------------------------------------------------------------------------------------------------------------------------------------------------------------------------------------------------------|
| Cause | Solution |
| Invalid media reported. | When formatting a disk in MS-DOS, you may need to specify diskette capacity. For example, to format a 1.44-MB diskette, type the following command at the MS-DOS prompt: FORMAT A: /F:1440 |
| Disk may be write-protected. | Open the locking device on the diskette. |
| Legacy diskette writes are disabled in Computer Setup. | Enter Computer Setup and enable Legacy Diskette Write in Storage > Storage Options . |

| A problem has occurred with a disk transaction. | |
|--------------------------------------------------------------------|-----------------------------------------------------------------------------------------------------------------------------------------------------------------------------------------------------------------------------------------------------------------------------------------------------------------------------------------------------------------------------------------------------------------------------------------------------|
| Cause | Solution |
| The directory structure is bad, or there is a problem with a file. | In Microsoft Windows XP, right-click Start , click Explore , and select a drive. Select File > Properties > Tools . Under Error-checking , click Check Now . In Microsoft Windows Vista or Windows 7, right-click Start , click Explore , and right-click on a drive. Select Properties then select the Tools tab. Under Error-checking click Check Now . |

| Diskette drive cannot read a diskette. | |
|-----------------------------------------------------------|-------------------------------------------------------------------------------|
| Cause | Solution |
| You are using the wrong diskette type for the drive type. | Check the type of drive that you are using and use the correct diskette type. |
| You are reading the wrong drive. | Check the drive letter in the path statement. |
| Diskette is damaged. | Replace the diskette with a new one. |

“Invalid system disk” message is displayed.

| Cause | Solution |
|----------------------------------------------------------------------------------------------------------------|-----------------------------------------------------------------------------------------------------------------------|
| A diskette that does not contain the system files needed to start the computer has been inserted in the drive. | When drive activity stops, remove the diskette and press the Spacebar . The computer should start up. |
| Diskette error has occurred. | Restart the computer by pressing the power button. |

Cannot Boot to Diskette.

| Cause | Solution |
|----------------------------------------------------|------------------------------------------------------------------------------------------------------------------------------------------------------------------------------------------------------------------------------------------------------------------------------------------------------------------------------------------------------------------------------------------------------------------|
| Diskette is not bootable. | Replace with a bootable diskette. |
| Diskette boot has been disabled in Computer Setup. | <ol style="list-style-type: none">1. Run Computer Setup and enable USB device in Storage > Boot Order.2. Run Computer Setup and enable USB device in Storage > Storage Options > Removable Media Boot. <p>NOTE: Both steps should be used as the Removable Media Boot function in Computer Setup overrides the Boot Order enable command.</p> |
| Network server mode is enabled in Computer Setup. | Run Computer Setup and disable Network Server Mode in Security > Password Options . |

Solving Hard Drive Problems

Table B-4 Solving Hard Drive Problems

| Hard drive error occurs. | |
|-------------------------------------------------------------------------------|-----------------------------------------------------------------------------------------------------------------------------------------------------------------------------------------------------------------------------------------------------------------------------------------------------------------------------------------------------------------------------------------------------------------------------------------------------------------------------------------------------------------------------------------------------------------------------------------------------------|
| Cause | Solution |
| Hard disk has bad sectors or has failed. | <ol style="list-style-type: none">1. In Microsoft Windows XP, right-click Start, click Explore, and select a drive. Select File > Properties > Tools. Under Error-checking, click Check Now. In Microsoft Windows Vista or Windows 7, right-click Start, click Explore, and right-click on a drive. Select Properties then select the Tools tab. Under Error-checking click Check Now.2. Use a utility to locate and block usage of bad sectors. If necessary, reformat the hard disk. |
| Disk transaction problem. | |
| Cause | Solution |
| Either the directory structure is bad or there is a problem with a file. | <p>In Microsoft Windows XP, right-click Start, click Explore, and select a drive. Select File > Properties > Tools. Under Error-checking, click Check Now.</p> <p>In Microsoft Windows Vista or Windows 7, right-click Start, click Explore, and right-click on a drive. Select Properties then select the Tools tab. Under Error-checking click Check Now.</p> |
| Drive not found (identified). | |
| Cause | Solution |
| Cable could be loose. | Check cable connections. |
| The system may not have automatically recognized a newly installed device. | <p>See reconfiguration directions in the Solving Hardware Installation Problems on page 134 section. If the system still does not recognize the new device, check to see if the device is listed within Computer Setup. If it is listed, the probable cause is a driver problem. If it is not listed, the probable cause is a hardware problem.</p> <p>If this is a newly installed drive, run the Computer Setup utility and try adding a POST delay under Advanced > Power-On.</p> |
| The device is attached to a SATA port that has been hidden in Computer Setup. | Run the Computer Setup utility and ensure Device Available is selected for the device's SATA port in Security > Device Security . |
| Drive responds slowly immediately after power-up. | Run Computer Setup and increase the POST Delay in Advanced > Power-On Options . |

Nonsystem disk/NTLDR missing message.

| Cause | Solution |
|---------------------------------------------------------------------------------------------|---------------------------------------------------------------------------------------------------------------------------------------------------------------------------------------------------------------------------------------------------------------------------------------------------------------------------------------------------------------------------------------|
| The system is trying to start from a diskette that is not bootable. | Remove the diskette from the diskette drive. |
| The system is trying to start from the hard drive but the hard drive may have been damaged. | <ol style="list-style-type: none">1. Insert a bootable diskette into the diskette drive and restart the computer.2. Check the hard drive format using fdisk: If NTFS formatting, use a third party reader to evaluate the drive. If FAT32 formatting, the hard drive cannot be accessed. |
| System files missing or not properly installed. | <ol style="list-style-type: none">1. Insert a bootable diskette into the diskette drive and restart the computer.2. Check the hard drive format using Fdisk: If NTFS formatting, use a third party reader to evaluate the drive. If FAT32 formatting, the hard drive cannot be accessed.3. Install system files for the appropriate operating system. |
| Hard drive boot has been disabled in Computer Setup. | Run the Computer Setup utility and enable the hard drive entry in the Storage > Boot Order list. |
| Bootable hard drive is not attached as first in a multi-hard drive configuration. | If attempting to boot from a hard drive, ensure it is attached to the system board dark blue SATA connector. |
| Bootable hard drive's controller is not listed first in the Boot Order. | Run the Computer Setup utility and select Storage > Boot Order and ensure the bootable hard drive's controller is listed immediately under the Hard Drive entry. |

Computer will not boot from hard drive.

| Cause | Solution |
|-------------------------------------------------------------------------------|----------------------------------------------------------------------------------------------------------------------------------------------------------------------------------------------------------------------------------------------------------------------------------------|
| The device is attached to a SATA port that has been hidden in Computer Setup. | Run the Computer Setup utility and ensure Device Available is selected for the device's SATA port in Security > Device Security . |
| Boot order is not correct. | Run the Computer Setup utility and change boot sequence in Storage > Boot Order . |
| Hard Drive's "Emulation Type" is set to "None." | Run the Computer Setup utility and change the "Emulation Type" to "Hard Disk" in the device's details under Storage > Device Configuration . |
| Hard drive is damaged. | Observe if the front panel Power LED is blinking RED and if any beeps are heard. See Appendix A, POST Error Messages on page 102 to determine possible causes for the blinking red and beep codes. See the Worldwide Limited Warranty for terms and conditions. |

Computer seems to be locked up.

| Cause | Solution |
|----------------------------------------------------|------------------------------------------------------------------------------------------------------------------------------------------------------------------------------------------------|
| Program in use has stopped responding to commands. | Attempt the normal Windows "Shut Down" procedure. If this fails, press the power button for four or more seconds to turn off the power. To restart the computer, press the power button again. |

The removable hard drive is not recognized by the computer.

| Cause | Solution |
|-----------------------------------------------------------------------------------------------------------------------------------|------------------------------------------------------------------------------------------------------------------------------------------------------------------------------------------------------------------------------------------------------------------------------------|
| The removable hard drive carrier is not fully seated in the enclosure frame or the hard drive is not fully seated in the carrier. | Push the carrier into the enclosure frame so that the connector on the rear of the frame is properly seated. If this does not solve the problem, turn off the computer, remove the carrier, and check to see if the connector on the hard drive is properly seated in the carrier. |

The removable hard drive enclosure is beeping and the green LED is flashing.

| Cause | Solution |
|-----------------------------------------------------------------------------|--------------------------------------------------------------------|
| Fan failure alarm on the removable hard drive enclosure has been activated. | Shut down the computer and contact HP for a replacement enclosure. |

Solving Media Card Reader Problems

Table B-5 Solving Media Card Reader Problems

Media card will not work in a digital camera after formatting it in Microsoft Windows XP or Microsoft Windows Vista.

| Cause | Solution |
|------------------------------------------------------------------------------------------------------------------------------------------------------------------------------------------------------------------|-----------------------------------------------------------------------------------------------------------------------------------|
| By default, Windows will format any media card with a capacity greater than 32MB with the FAT32 format. Most digital cameras use the FAT (FAT16 & FAT12) format and can not operate with a FAT32 formatted card. | Either format the media card in the digital camera or select FAT file system to format the media card in a computer with Windows. |

A write-protected or locked error occurs when attempting to write to the media card.

| Cause | Solution |
|------------------------------------------------------------------------------------------------------------------------------------------|---------------------------------------------------------------------------------------------------------------------------------------------------------------------------------------------------------------------------------------------------------------------|
| Media card is locked. Locking the media card is a safety feature that prevents writing to and deleting from an SD/Memory Stick/PRO card. | If using an SD card, make sure that the lock tab located on the right of the SD card is not in the locked position. If using a Memory Stick/PRO card, make sure that the lock tab located on the bottom of the Memory Stick/PRO card is not in the locked position. |

Can not write to the media card.

| Cause | Solution |
|------------------------------------------------------------------------------------------------------------------------------------------|---------------------------------------------------------------------------------------------------------------------------------------------------------------------------------------------------------------------------------------------------------------------|
| The media card is a read-only memory (ROM) card. | Check the manufacturer's documentation included with your card to see if it is writable. Refer to the previous section for a list of compatible cards. |
| Media card is locked. Locking the media card is a safety feature that prevents writing to and deleting from an SD/Memory Stick/PRO card. | If using an SD card, make sure that the lock tab located on the right of the SD card is not in the locked position. If using a Memory Stick/PRO card, make sure that the lock tab located on the bottom of the Memory Stick/PRO card is not in the locked position. |

Unable to access data on the media card after inserting it into a slot.

| Cause | Solution |
|----------------------------------------------------------------------------------------------|-------------------------------------------------------------------------------------------------------------------------------------|
| The media card is not inserted properly, is inserted in the wrong slot, or is not supported. | Ensure that the card is inserted properly with the gold contact on the correct side. The green LED will light if inserted properly. |

Do not know how to remove a media card correctly.

| Cause | Solution |
|-----------------------------------------------------------|------------------------------------------------------------------------------------------------------------------------------------------------------------------------------------------------------------------------------------------------------------------------|
| The computer's software is used to safely eject the card. | Open My Computer (Windows XP) or Computer (Windows Vista/Windows 7), right-click on the corresponding drive icon, and select Eject . Then pull the card out of the slot. NOTE: Never remove the card when the green LED is flashing |

After installing the media card reader and booting to Windows, the reader and the inserted cards are not recognized by the computer.

| Cause | Solution |
|--------------------------------------------------------------------------------------------------------------------------------------------------------------|----------------------------------------------------------------------------------------------------------------------------------------------------------------|
| The operating system needs time to recognize the device if the reader was just installed into the computer and you are turning the PC on for the first time. | Wait a few seconds so that the operating system can recognize the reader and the available ports, and then recognize whatever media is inserted in the reader. |

After inserting a media card in the reader, the computer attempts to boot from the media card.

| Cause | Solution |
|----------------------------------------------|-----------------------------------------------------------------------------------------------------------------------------------------------------------------|
| The inserted media card has boot capability. | If you do not want to boot from the media card, remove it during boot or do not select the option to boot from the inserted media card during the boot process. |

Solving Display Problems

If you encounter display problems, see the documentation that came with the monitor and to the common causes and solutions listed in the following table.

Table B-6 Solving Display Problems

Blank screen (no video).

| Cause | Solution |
|--------------------------------------------------------------------------------------------------------------|--------------------------------------------------------------------------------------------------------------------------------------------------------------------------------------------------------------------------------------------------------------------------------|
| You may have a screen blanking utility installed or energy saver features are enabled. | Press any key or click the mouse button and, if set, type your password. |
| System ROM is corrupted; system is running in Boot Block Emergency Recovery Mode (indicated by eight beeps). | Reflash the system ROM with the latest BIOS image. |
| Computer is in standby mode. | Press the power button to resume from standby mode. CAUTION: When attempting to resume from standby mode, do not hold down the power button for more than four seconds. Otherwise, the computer will shut down and you will lose any unsaved data. |

Blank screen and the power LED flashes red five times, once every second, followed by a two second pause, and the computer beeps five times. (Beeps stop after fifth iteration but LEDs continue flashing.)

| Cause | Solution |
|-------------------------|-------------------------------------------------------------------------------------------------------------------------------------------------------------------------------------------------------------------------------------------------------|
| Pre-video memory error. | <ol style="list-style-type: none">1. Reseat DIMMs. Power on the system.2. Replace DIMMs one at a time to isolate the faulty module.3. Replace third-party memory with HP memory.4. Replace the system board. |

Blank screen and the power LED flashes red six times, once every second, followed by a two second pause, and the computer beeps six times. (Beeps stop after fifth iteration but LEDs continue flashing.)

| Cause | Solution |
|---------------------------|--------------------------------------------------------------------------------------------------------------------------------------------------------------------------------------------------------------------------------------------------------------------------------------|
| Pre-video graphics error. | For systems with a graphics card: <ol style="list-style-type: none">1. Reseat the graphics card. Power on the system.2. Replace the graphics card.3. Replace the system board. For systems with integrated graphics, replace the system board. |

Blank screen and the power LED flashes red seven times, once every second, followed by a two second pause, and the computer beeps seven times. (Beeps stop after fifth iteration but LEDs continue flashing.)

| Cause | Solution |
|-------------------------------------------------------------|---------------------------|
| System board failure (ROM detected failure prior to video). | Replace the system board. |

Monitor does not function properly when used with energy saver features.

| Cause | Solution |
|---------------------------------------------------------------------------------------------|---------------------------------------|
| Monitor without energy saver capabilities is being used with energy saver features enabled. | Disable monitor energy saver feature. |

Dim characters.

| Cause | Solution |
|------------------------------------------------------------|-------------------------------------------------------------------------------------------|
| The brightness and contrast controls are not set properly. | Adjust the monitor brightness and contrast controls. |
| Cables are not properly connected. | Check that the graphics cable is securely connected to the graphics card and the monitor. |

Blurry video or requested resolution cannot be set.

| Cause | Solution |
|------------------------------------------------------------------------------------------|--------------------------------------------------------|
| If the graphics controller was upgraded, the correct graphics drivers may not be loaded. | Install the video drivers included in the upgrade kit. |
| Monitor is not capable of displaying requested resolution. | Change requested resolution. |
| Graphics card is bad. | Replace the graphics card. |

The picture is broken up, rolls, jitters, or flashes.

| Cause | Solution |
|---------------------------------------------------------------------------------------|-------------------------------------------------------------------------------------------------------------------------------------------------------------------------------------------------------------------------------------------------------------------------------------------------------|
| The monitor connections may be incomplete or the monitor may be incorrectly adjusted. | <ol style="list-style-type: none">1. In a two-monitor system or if another monitor is in close proximity, be sure the monitors are not interfering with each other's electromagnetic field by moving them apart.2. Fluorescent lights or fans may be too close to the monitor. |
| Monitor needs to be degaussed. | Degauss the monitor. Refer to the documentation that came with the monitor for instructions. |

Image is not centered.

| Cause | Solution |
|-------------------------------|-------------------------------------------------------------------------------------------------------------------------------------------------------------------------------------------------|
| Position may need adjustment. | Press the monitor's Menu button to access the OSD menu. Select ImageControl/ Horizontal Position or Vertical Position to adjust the horizontal or vertical position of the image. |

"Out of Range" displays on screen.

| Cause | Solution |
|----------------------------------------------------------------------------------|------------------------------------------------------------------------------------------------------------------------------------------------------|
| Video resolution and refresh rate are set higher than what the monitor supports. | Restart the computer and enter Safe Mode. Change the settings to a supported setting then restart the computer so that the new settings take effect. |

High pitched noise coming from inside monitor.

| Cause | Solution |
|---------------------------------------------------|--------------------------------------------|
| Brightness and/or contrast settings are too high. | Lower brightness and/or contrast settings. |

Fuzzy focus; streaking, ghosting, or shadowing effects; horizontal scrolling lines; faint vertical bars; or unable to center the picture on the screen (flat panel monitors using an analog VGA input connection only).

| Cause | Solution |
|--------------------------------------------------------------------------------------------------------------------------------------|---------------------------------------------------------------------------------------------------------------------------------------------------------------------------------------------------------------------------------------------------------------------------------------------------------------------------------------------------------------------------------------------------------------------------------------------------------------------------------|
| Monitor's internal digital conversion circuits may be unable to correctly interpret the output synchronization of the graphics card. | <ol style="list-style-type: none">1. Select the monitor's Auto-Adjustment option in the monitor's on-screen display menu.2. Manually synchronize the Clock and Clock Phase on-screen display functions. To download a SoftPaq that will assist you with the synchronization, go to the following Web site, select the appropriate monitor, and download either SP32347 or SP32202: http://www.hp.com/support |
| Graphics card is not seated properly or is bad. | <ol style="list-style-type: none">1. Reseat the graphics card.2. Replace the graphics card. |

Certain typed symbols do not appear correct.

| Cause | Solution |
|-----------------------------------------------------------------|---------------------------------------------------------------------------------------------------------------------------------------------------------------------------------------------------------------------------------|
| The font you are using does not support that particular symbol. | Use the Character Map to locate and select the appropriate symbol. Click Start > All Programs > Accessories > System Tools > Character Map . You can copy the symbol from the Character Map into a document. |

Solving Audio Problems

If the computer has audio features and you encounter audio problems, see the common causes and solutions listed in the following table.

Table B-7 Solving Audio Problems

| Sound cuts in and out. | |
|-----------------------------------------------------------------|-----------------------------------------------------------------------------------------------------------------------------------------------------------------------------------------------------------------------------------------------------------------------------------------------------------------------------------------------------------------------------------------------------------------------------------------------------------------------------------------------------------------------------------------------------------------------------------------------------------------------------------------------------------|
| Cause | Solution |
| Processor resources are being used by other open applications. | Shut down all open processor-intensive applications. |
| Direct sound latency, common in many media player applications. | In Windows XP only: <ol style="list-style-type: none">1. From the Control Panel, select Sounds and Audio Devices.2. On the Audio tab, select a device from the Sound Playback list.3. Click the Advanced button and select the Performance tab.4. Set the Hardware acceleration slider to None and the Sample rate conversion quality slider to Good and retest the audio.5. Set the Hardware acceleration slider to Full and the Sample rate conversion quality slider to Best and retest the audio. |

| Sound does not come out of the speaker or headphones. | |
|-----------------------------------------------------------------------------------------|---------------------------------------------------------------------------------------------------------------------------------------------------------------------------------------------------------|
| Cause | Solution |
| Software volume control is turned down or muted. | Double-click the Speaker icon on the taskbar, then make sure that Mute is not selected and use the volume slider to adjust the volume. |
| Audio is hidden in Computer Setup. | Enable the audio in Computer Setup: Security > Device Security > System Audio . |
| The external speakers are not turned on. | Turn on the external speakers. |
| The audio device may be connected to the wrong jack. | Ensure that the device is connected to the correct jack on the computer. The speakers should be plugged into the rear line-out jack and the headphones should be plugged into the front headphone jack. |
| External speakers plugged into the wrong audio jack on a recently installed sound card. | See the sound card documentation for proper speaker connection. |
| Digital CD audio is not enabled. | Enable digital CD audio. In the Device Manager, right-click on the CD/DVD device and select Properties . Make sure Enable digital CD audio for this CD-ROM device is checked. |
| Headphones or devices connected to the line-out connector mute the internal speaker. | Turn on and use headphones or external speakers, if connected, or disconnect headphones or external speakers. |

Table B-7 Solving Audio Problems (continued)

Sound does not come out of the speaker or headphones.

| Cause | Solution |
|------------------------------------------------------------------------------------------------------------------------------|--------------------------------------------------------------------------------------------------------------------------------------------------------------------------------------------------------------------------------------------------------------------------------|
| Computer is in standby mode. | Press the power button to resume from standby mode. CAUTION: When attempting to resume from standby mode, do not hold down the power button for more than four seconds. Otherwise, the computer will shut down and you will lose any unsaved data. |
| Internal speaker is disabled in Computer Setup. | Enable the internal speaker in Computer Setup. Select Advanced > Device Options > Internal Speaker . |
| The application is set to use a different audio device than speakers. | Some graphics cards support audio over the DisplayPort connection, so multiple audio devices may be listed in Device Manager. Make sure the correct device is being used. |
| Some applications can select which audio output device is used. | Make sure the application has selected the correct audio device. |
| The operating system controls may be set to use a different audio device as the default output device than what is expected. | Set the operating system to use the correct audio device. |

Sound from headphones is not clear or muffled.

| Cause | Solution |
|------------------------------------------------------------------------------------------------------------------------------------------------------------------|--------------------------------------------------------------------------------|
| Headphones are plugged into the rear audio output connector. The rear audio output connector is for powered audio devices and is not designed for headphone use. | Plug the headphones into the headphone connector on the front of the computer. |

Computer appears to be locked up while recording audio.

| Cause | Solution |
|----------------------------|--------------------------------------------------------------------------------------------------------------------------------------------|
| The hard disk may be full. | Before recording, make sure there is enough free space on the hard disk. You can also try recording the audio file in a compressed format. |

Line-in jack is not functioning properly.

| Cause | Solution |
|-------------------------------------------------------------------------|---------------------------------------------------------------------------------------------------------|
| Jack has been reconfigured in the audio driver or application software. | In the audio driver or application software, reconfigure the jack or set the jack to its default value. |

There is no sound or sound volume is too low.

| Cause | Solution |
|------------------------------------------------------------------------------------------------------------------------------|---------------------------------------------------------------------------------------------------------------------------------------------------------------------------|
| The application is set to use a different audio device than speakers. | Some graphics cards support audio over the DisplayPort connection, so multiple audio devices may be listed in Device Manager. Make sure the correct device is being used. |
| Some applications can select which audio output device is used. | Make sure the application has selected the correct audio device. |
| The operating system controls may be set to use a different audio device as the default output device than what is expected. | Set the operating system to use the correct audio device. |

Solving Printer Problems

If you encounter printer problems, see the documentation that came with the printer and to the common causes and solutions listed in the following table.

Table B-8 Solving Printer Problems

Printer will not print.

| Cause | Solution |
|-------------------------------------------------------------------------------|-----------------------------------------------------------------------------------------------------------------------------------------------------------------------------------------------------------------------------------------------------------------------------------------------------------------------------------------|
| Printer is not turned on and online. | Turn the printer on and make sure it is online. |
| The correct printer drivers for the application are not installed. | <ol style="list-style-type: none">1. Install the correct printer driver for the application.2. Try printing using the MS-DOS command: <code>DIR C:\ > [printer port]</code> where [printer port] is the address of the printer being used. If the printer works, reload the printer driver. |
| If you are on a network, you may not have made the connection to the printer. | Make the proper network connections to the printer. |
| Printer may have failed. | Run printer self-test. |

Printer will not turn on.

| Cause | Solution |
|-------------------------------------------|----------------------------------------------------------------------|
| The cables may not be connected properly. | Reconnect all cables and check the power cord and electrical outlet. |

Printer prints garbled information.

| Cause | Solution |
|------------------------------------------------------------------|---------------------------------------------------------|
| The correct printer driver for the application is not installed. | Install the correct printer driver for the application. |

Table B-8 Solving Printer Problems (continued)

Printer prints garbled information.

| Cause | Solution |
|-------------------------------------------|---------------------------------------------------------------------------|
| The cables may not be connected properly. | Reconnect all cables. |
| Printer memory may be overloaded. | Reset the printer by turning it off for one minute, then turn it back on. |

Printer is offline.

| Cause | Solution |
|----------------------------------|-------------------------------------------------------------------|
| The printer may be out of paper. | Check the paper tray and refill it if it is empty. Select online. |

Solving Keyboard and Mouse Problems

If you encounter keyboard or mouse problems, see the documentation that came with the equipment and to the common causes and solutions listed in the following table.

Table B-9 Solving Keyboard Problems

Keyboard commands and typing are not recognized by the computer.

| Cause | Solution |
|----------------------------------------------------|-------------------------------------------------------------------------------------------------------------------------------------------------------------------------------------------------------------------------------------------------------------------------------------------------------------------------------------------------------------------------------------------------------------|
| Keyboard connector is not properly connected. | <ol style="list-style-type: none">1. On the Windows XP Desktop, click Start > Shut Down. On the Windows Vista or Windows 7 Desktop, click Start, click the arrow on the lower right corner of the Start menu, then select Shut Down.2. After the shutdown is complete, reconnect the keyboard to the back of the computer and restart the computer. |
| Program in use has stopped responding to commands. | Shut down your computer using the mouse and then restart the computer. |
| Keyboard needs repairs. | See the Worldwide Limited Warranty for terms and conditions. |
| Computer is in standby mode. | Press the power button to resume from standby mode. CAUTION: When attempting to resume from standby mode, do not hold down the power button for more than four seconds. Otherwise, the computer will shut down and you will lose any unsaved data. |

Cursor will not move using the [arrow](#) keys on the keypad.

| Cause | Solution |
|---------------------------------------------|-----------------------------------------------------------------------------------------------------------------------------------------------------------------------------------------------------------------|
| The Num Lock key may be on. | Press the Num Lock key. The Num Lock light should not be on if you want to use the arrow keys. The Num Lock key can be disabled (or enabled) in Computer Setup. |

Table B-10 Solving Mouse Problems

| Mouse does not respond to movement or is too slow. | |
|---------------------------------------------------------------------------------------------|-------------------------------------------------------------------------------------------------------------------------------------------------------------------------------------------------------------------------------------------------------------------------------------------------------------------------------------------------------------------------------------------------------------------------------------------------------------------------|
| Cause | Solution |
| Mouse connector is not properly plugged into the back of the computer. | Shut down the computer using the keyboard. <ol style="list-style-type: none">1. Press the Ctrl and Esc keys at the same time (or press the Windows logo key) to display the Start menu.2. Use the arrow keys to select Shut Down and then press the Enter key.3. After the shutdown is complete, plug the mouse connector into the back of the computer (or the keyboard) and restart. |
| Program in use has stopped responding to commands. | Shut down the computer using the keyboard then restart the computer. |
| Mouse may need cleaning. | Remove the roller ball cover on the mouse and clean the internal components. |
| Mouse may need repair. | See the Worldwide Limited Warranty for terms and conditions. |
| Computer is in standby mode. | Press the power button to resume from standby mode. CAUTION: When attempting to resume from standby mode, do not hold down the power button for more than four seconds. Otherwise, the computer will shut down and you will lose any unsaved data. |
| Mouse will only move vertically, horizontally, or movement is jerky. | |
| Cause | Solution |
| Mouse roller ball or the rotating encoder shafts that make contact with the ball are dirty. | Remove roller ball cover from the bottom of the mouse and clean the internal components with a mouse cleaning kit available from most computer stores. |

Solving Hardware Installation Problems

You may need to reconfigure the computer when you add or remove hardware, such as an additional drive or expansion card. If you install a plug and play device, Windows automatically recognizes the device and configures the computer. If you install a non–plug and play device, you must reconfigure the computer after completing installation of the new hardware. In Windows, use the **Add Hardware Wizard** and follow the instructions that appear on the screen.

⚠ WARNING! When the computer is plugged into an AC power source, voltage is always applied to the system board. To reduce the risk of personal injury from electrical shock and/or hot surfaces, be sure to disconnect the power cord from the wall outlet and allow the internal system components to cool before touching.

Table B-11 Solving Hardware Installation Problems

A new device is not recognized as part of the system.

| Cause | Solution |
|-----------------------------------------------------------------------------------------------------------------------------|-----------------------------------------------------------------------------------------------------------------------------------------------------------------------------------------------------------------------------------------------------------|
| Device is not seated or connected properly. | Ensure that the device is properly and securely connected and that pins in the connector are not bent down. |
| Cable(s) of new external device are loose or power cables are unplugged. | Ensure that all cables are properly and securely connected and that pins in the cable or connector are not bent down. |
| Power switch of new external device is not turned on. | Turn off the computer, turn on the external device, then turn on the computer to integrate the device with the computer system. |
| When the system advised you of changes to the configuration, you did not accept them. | Reboot the computer and follow the instructions for accepting the changes. |
| A plug and play board may not automatically configure when added if the default configuration conflicts with other devices. | Use Windows Device Manager to deselect the automatic settings for the board and choose a basic configuration that does not cause a resource conflict. You can also use Computer Setup to reconfigure or disable devices to resolve the resource conflict. |
| USB ports on the computer are disabled in Computer Setup. | Run the Computer Setup utility and ensure that Device available is selected for appropriate USB ports under Security > USB Security . |

Computer will not start.

| Cause | Solution |
|-------------------------------------------------------------------------------------------------------|--------------------------------------------------------------------------------------------------------------------------------------------------------------------------------------------------------------------------------------------------------------------------------------------------------------------------------------------------------------------------------------------------------------------------------------------------------------------------------------------------------------------------------------------------------------------|
| Wrong memory modules were used in the upgrade or memory modules were installed in the wrong location. | <ol style="list-style-type: none">1. Review the documentation that came with the system to determine if you are using the correct memory modules and to verify the proper installation. NOTE: DIMM1 or XMM1 must always be installed. DIMM1 must be installed before DIMM2, and DIMM3 must be installed before DIMM4.2. Observe the beeps and LED lights on the front of the computer. Beeps and flashing LEDs are codes for specific problems.3. If you still cannot resolve the issue, contact Customer Support. |

Power LED flashes red five times, once every second, followed by a two second pause, and the computer beeps five times. (Beeps stop after fifth iteration but LEDs continue flashing.)

| Cause | Solution |
|--------------------------------------------|--------------------------------------------------------------------------------------------------------------------------------------------------------------------------------------------------------------------------------------------------------------------------------------------------------------------------------------------------------------------------------------------------------------------------------------------------------------------------------------------------------------------------------------------------------------------------------------------------------------------------|
| Memory is installed incorrectly or is bad. | <p>CAUTION: To avoid damage to the DIMMs or the system board, you must unplug the computer power cord before attempting to reseat, install, or remove a DIMM module.</p> <ol style="list-style-type: none">1. Reseat DIMMs. Power on the system.2. Replace DIMMs one at a time to isolate the faulty module. <p>NOTE: DIMM1 or XMM1 must always be installed. DIMM1 must be installed before DIMM2, and DIMM3 must be installed before DIMM4</p> <ol style="list-style-type: none">3. Replace third-party memory with HP memory.4. Replace the system board. |

Power LED flashes red six times, once every second, followed by a two second pause, and the computer beeps six times. (Beeps stop after fifth iteration but LEDs continue flashing.)

| Cause | Solution |
|-------------------------------------------------------------------------|----------------------------------------------------------------------------------------------------------------------------------------------------------------------------------------------------------------------------------------------------------------------------------------------|
| Graphics card is not seated properly or is bad, or system board is bad. | <p>For systems with a graphics card:</p> <ol style="list-style-type: none">1. Reseat the graphics card. Power on the system.2. Replace the graphics card.3. Replace the system board. <p>For systems with integrated graphics, replace the system board.</p> |

Power LED flashes red ten times, once every second, followed by a two second pause, and the computer beeps ten times. (Beeps stop after fifth iteration but LEDs continue flashing.)

| Cause | Solution |
|------------------|-------------------------------------------------------------------------------------------------------------------------------------------------------------------------------------------------------------------------------------------------------------------------------------------------------|
| Bad option card. | <ol style="list-style-type: none">1. Check each option card by removing the cards one at time (if multiple cards), then power on the system to see if fault goes away.2. Once bad card is identified, remove and replace bad option card.3. Replace the system board. |

Solving Network Problems

Some common causes and solutions for network problems are listed in the following table. These guidelines do not discuss the process of debugging the network cabling.

Table B-12 Solving Network Problems

Wake-on-LAN feature is not functioning.

| Cause | Solution |
|---------------------------------------------|-------------------------------------------------------------------------------------------------------------------------------------------------|
| S5 Maximum Power Saving feature is enabled. | Disable the S5 Maximum Power Saving option in Computer Setup. Select Power > Hardware Power Management > S5 Maximum Power Saving . |

Table B-12 Solving Network Problems (continued)

Wake-on-LAN feature is not functioning.

| Cause | Solution |
|-----------------------------|---------------------------------------------------------------------------------------------------------------------------------------------------------------------------------------------------------------------------------------------------------------------------------------------------------------------------------------------------------------------------------------------------------------------------------------------------------------------------------------------------------------------------------------------------------------------------------------------------------------------------------------------------------------------------------------------------------------------------------------------------------------------------------------------------------------------------------------------------------------------------------------------------------------------------------------------------------------------------------------------------------------------------------------------------------------------------------------------------------------------------------------------------------------------------------------------------------------------------------------------------------------------------------------------------------------------------------------------------------------------------------------------------------------------------------------------------------------------------------------------------------------------------------------------------------------------------------------|
| S5 Wake on LAN is disabled. | : Enable the S5 Wake on LAN option in Computer Setup. Select Advanced > Device Options > S5 Wake on LAN . |
| Wake-on-LAN is not enabled. | <p>To enable Wake-on-LAN in Windows XP:</p> <ol style="list-style-type: none">1. Select Start > Control Panel.2. Double-click Network Connections.3. Double-click Local Area Connection.4. Click Properties.5. Click Configure.6. Click the Power Management tab, then select the check box to Allow this device to bring the computer out of standby. <p>To enable Wake-on-LAN in Windows Vista:</p> <ol style="list-style-type: none">1. Select Start > Control Panel.2. Under Network and Internet, select View network status and tasks.3. In the Tasks list, select Manage network connections.4. Double-click Local Area Connection.5. Click the Properties button.6. Click the Configure button.7. Click the Power Management tab, then select the check box to Allow this device to wake the computer. <p>To enable Wake-on-LAN in Windows 7:</p> <ol style="list-style-type: none">1. Select Start > Control Panel.2. Under Network and Internet, select View network status and tasks.3. Click Local Area Connection.4. Click the Properties button.5. Click the Configure button.6. Click the Power Management tab, then select the check box to Allow this device to wake the computer. |

Network driver does not detect network controller.

| Cause | Solution |
|---------------------------------|-------------------------------------------------------------------------------------------------------------------------------------------------------------------------------------------|
| Network controller is disabled. | <ol style="list-style-type: none">1. Run Computer Setup and enable network controller.2. Enable the network controller in the operating system via Device Manager. |
| Incorrect network driver. | Check the network controller documentation for the correct driver or obtain the latest driver from the manufacturer's Web site. |

Network status link light never flashes.

NOTE: The network status light is supposed to flash when there is network activity.

| Cause | Solution |
|--------------------------------------------|-------------------------------------------------------------------------------------------------------------------------------------------------------------------------------------------|
| No active network is detected. | Check cabling and network equipment for proper connection. |
| Network controller is not set up properly. | Check for the device status within Windows, such as Device Manager for driver load and the Network Connections applet within Windows for link status. |
| Network controller is disabled. | <ol style="list-style-type: none">1. Run Computer Setup and enable network controller.2. Enable the network controller in the operating system via Device Manager. |
| Network driver is not properly loaded. | Reinstall network drivers. |
| System cannot autosense the network. | Disable auto-sensing capabilities and force the system into the correct operating mode. |

Diagnostics reports a failure.

| Cause | Solution |
|------------------------------------------------------------------------------|-----------------------------------------------------------------------------------------------------------------------------------------------------|
| The cable is not securely connected. | Ensure that the cable is securely attached to the network connector and that the other end of the cable is securely attached to the correct device. |
| The cable is attached to the incorrect connector. | Ensure that the cable is attached to the correct connector. |
| There is a problem with the cable or a device at the other end of the cable. | Ensure that the cable and device at the other end are operating correctly. |
| Network controller interrupt is shared with an expansion board. | Under the Computer Setup Advanced menu, change the resource settings for the board. |
| The network controller is defective. | Contact an authorized service provider. |

Diagnostics passes, but the computer does not communicate with the network.

| Cause | Solution |
|------------------------------------------------------------------------------------------|---------------------------------------------------------------------------------------------------------------------------------------------------------------------------------------------------|
| Network drivers are not loaded, or driver parameters do not match current configuration. | Make sure the network drivers are loaded and that the driver parameters match the configuration of the network controller. Make sure the correct network client and protocol is installed. |
| The network controller is not configured for this computer. | Select the Network icon in the Control Panel and configure the network controller. |

Network controller stopped working when an expansion board was added to the computer.

| Cause | Solution |
|--------------------------------------------------------------------------------------------|------------------------------------------------------------------------------------------------------------------|
| Network controller interrupt is shared with an expansion board. | Under the Computer Setup Advanced menu, change the resource settings for the board. |
| The network controller requires drivers. | Verify that the drivers were not accidentally deleted when the drivers for a new expansion board were installed. |
| The expansion board installed is a network card (NIC) and conflicts with the embedded NIC. | Under the Computer Setup Advanced menu, change the resource settings for the board. |

Network controller stops working without apparent cause.

| Cause | Solution |
|---------------------------------------------------------|-----------------------------------------------------------------------------------------------------------------------------------------------------|
| The files containing the network drivers are corrupted. | Reinstall the network drivers, using the Recovery Disc Set created from the hard drive's Recovery Partition. |
| The cable is not securely connected. | Ensure that the cable is securely attached to the network connector and that the other end of the cable is securely attached to the correct device. |
| The network controller is defective. | Contact an authorized service provider. |

New network card will not boot.

| Cause | Solution |
|-------------------------------------------------------------------------------------|----------------------------------------------------------------------------------------------------|
| New network card may be defective or may not meet industry-standard specifications. | Install a working, industry-standard NIC, or change the boot sequence to boot from another source. |

Cannot connect to network server when attempting Remote System Installation.

| Cause | Solution |
|----------------------------------------------------|---------------------------------------------------------------------------------------------------------------------------------------------------|
| The network controller is not configured properly. | Verify Network Connectivity, that a DHCP Server is present, and that the Remote System Installation Server contains the NIC drivers for your NIC. |

System setup utility reports unprogrammed EEPROM.

| Cause | Solution |
|----------------------|-----------------------------------------|
| Unprogrammed EEPROM. | Contact an authorized service provider. |

Solving Memory Problems

If you encounter memory problems, some common causes and solutions are listed in the following table.

⚠ CAUTION: Power may still be supplied to the DIMMs when the computer is turned off (depending on the Management Engine (ME) settings). To avoid damage to the DIMMs or the system board, you must unplug the computer power cord before attempting to reseat, install, or remove a DIMM module.

For those systems that support ECC memory, HP does not support mixing ECC and non-ECC memory. Otherwise, the computer will not boot the operating system.

Table B-13 Solving Memory Problems

System will not boot or does not function properly after installing additional memory modules.

| Cause | Solution |
|----------------------------------------------------------------------------------------------------------------------|-----------------------------------------------------------------------------------------------------------------------------------------------|
| A memory module is not installed in the DIMM1 or XMM1 socket. | Ensure that a memory module is installed in the DIMM1 or XMM1 socket on the system board. This socket must be populated with a memory module. |
| Memory module is not the correct type or speed grade for the system or the new memory module is not seated properly. | Replace module with the correct industry-standard device for the computer. On some models, ECC and non-ECC memory modules cannot be mixed. |

Out of memory error.

| Cause | Solution |
|----------------------------------------------------|---------------------------------------------------------------------------|
| Memory configuration may not be set up correctly. | Use the Device Manager to check memory configuration. |
| You have run out of memory to run the application. | Check the application documentation to determine the memory requirements. |

Memory count during POST is wrong.

| Cause | Solution |
|----------------------------------------------------|-----------------------------------------------------------------------------------------------|
| The memory modules may not be installed correctly. | Check that the memory modules have been installed correctly and that proper modules are used. |
| Integrated graphics may use system memory. | No action required. |

Insufficient memory error during operation.

| Cause | Solution |
|---------------------------------------------------------------------|---------------------------------------------------------------------------------------|
| Too many Terminate and Stay Resident programs (TSRs) are installed. | Delete any TSRs that you do not need. |
| You have run out of memory for the application. | Check the memory requirements for the application or add more memory to the computer. |

Power LED flashes red five times, once every second, followed by a two second pause, and the computer beeps five times. (Beeps stop after fifth iteration but LEDs continue flashing.)

| Cause | Solution |
|--------------------------------------------|-------------------------------------------------------------------------------------------------------------------------------------------------------------------------------------------------------------------------------------------------------|
| Memory is installed incorrectly or is bad. | <ol style="list-style-type: none">1. Reseat DIMMs. Power on the system.2. Replace DIMMs one at a time to isolate the faulty module.3. Replace third-party memory with HP memory.4. Replace the system board. |

Solving Processor Problems

If you encounter processor problems, common causes and solutions are listed in the following table.

Table B-14 Solving Processor Problems

Poor performance is experienced.

| Cause | Solution |
|-------------------|-------------------------------------------------------------------------------------------------------------------------------------------------------------------------------------------------------------------------------------------------------------------------------------|
| Processor is hot. | <ol style="list-style-type: none">1. Make sure the airflow to the computer is not blocked.2. Make sure the fans are connected and working properly (some fans only operate when needed).3. Make sure the processor heat sink is installed properly. |

Power LED flashes red three times, once every second, followed by a two second pause.

| Cause | Solution |
|----------------------------------------------------|---------------------------------------------------------------------------------------------------------------------------------|
| Processor is not seated properly or not installed. | <ol style="list-style-type: none">1. Check to see that the processor is present.2. Reseat the processor. |

Power LED flashes red eleven times, once every second, followed by a two second pause.

| Cause | Solution |
|-------------------------------------------------------------------------------------|----------------------------------------------------------------------------------------------------------------------------------------------------------------------------------------------|
| The current processor does not support a feature previously enabled on this system. | <ol style="list-style-type: none">1. Install a TXT capable processor.2. Disable TXT in the Computer Setup (F10) utility.3. Reinstall the original processor. |

Solving CD-ROM and DVD Problems

If you encounter CD-ROM or DVD problems, see the common causes and solutions listed in the following table or to the documentation that came with the optional device.

Table B-15 Solving CD-ROM and DVD Problems

System will not boot from CD-ROM or DVD drive.

| Cause | Solution |
|-------------------------------------------------------------------------------------------|----------------------------------------------------------------------------------------------------------------------------------------------------------------------------|
| The device is attached to a SATA port that has been hidden in the Computer Setup utility. | Run the Computer Setup utility and ensure Device Available is selected for the device's SATA port in Security > Device Security . |
| Removable Media Boot is disabled in the Computer Setup utility. | Run the Computer Setup utility and enable booting to removable media in Storage > Storage Options . Ensure CD-ROM is enabled in Storage > Boot Order . |
| Network Server Mode is enabled in Computer Setup. | Run the Computer Setup utility and disable Network Server Mode in Security > Password Options . |
| Non-bootable CD in drive. | Try a bootable CD in the drive. |
| Boot order not correct. | Run the Computer Setup utility and change boot sequence in Storage > Boot Order . |

Drive not found (identified).

| Cause | Solution |
|-------------------------------------------------------------------------------|------------------------------------------------------------------------------------------------------------------------------------------------------------------------------------------------------------------------------------------------------------------------------------------------------------------------------------------------------------------------------------------------------------------------------------------------------------------------------------------------------------------------|
| Cable could be loose. | Check cable connections. |
| The system may not have automatically recognized a newly installed device. | <p>See reconfiguration directions in the Solving Hardware Installation Problems on page 134 section. If the system still does not recognize the new device, check to see if the device is listed within Computer Setup. If it is listed, the probable cause is a driver problem. If it is not listed, the probable cause is a hardware problem.</p> <p>If this is a newly installed drive, run the Computer Setup utility and try adding a POST delay under Advanced > Power-On Options.</p> |
| The device is attached to a SATA port that has been hidden in Computer Setup. | Run the Computer Setup utility and ensure Device Available is selected for the device's SATA port in Security > Device Security . |
| Drive responds slowly immediately after power-up. | Run Computer Setup and increase the POST Delay in Advanced > Power-On Options . |

CD-ROM or DVD devices are not detected or driver is not loaded.

| Cause | Solution |
|-------------------------------------------------------------|-----------------------------------------------------------|
| Drive is not connected properly or not properly configured. | See the documentation that came with the optional device. |

Movie will not play in the DVD drive.

| Cause | Solution |
|----------------------------------------------------|-----------------------------------------------------|
| Movie may be regionalized for a different country. | See the documentation that came with the DVD drive. |
| Decoder software is not installed. | Install decoder software. |
| Damaged media. | Replace media. |
| Movie rating locked out by parental lock. | Use DVD software to remove parental lock. |
| Media installed upside down. | Reinstall media. |

Cannot eject compact disc (tray-load unit).

| Cause | Solution |
|----------------------------------------|--------------------------------------------------------------------------------------------------------------------------------------------------------------------------------------------------|
| Disc not properly seated in the drive. | Turn off the computer and insert a thin metal rod into the emergency eject hole and push firmly. Slowly pull the tray out from the drive until the tray is fully extended, then remove the disc. |

CD-ROM, CD-RW, DVD-ROM, or DVD-R/RW drive cannot read a disc or takes too long to start.

| Cause | Solution |
|-----------------------------------------------------------------------------------------------------------------------|---------------------------------------------------------------------------------------------------------------------------------------------------------------------------------------|
| Media has been inserted upside down. | Re-insert the media with the label facing up. |
| The DVD-ROM drive takes longer to start because it has to determine the type of media played, such as audio or video. | Wait at least 30 seconds to let the DVD-ROM drive determine the type of media being played. If the disc still does not start, read the other solutions listed for this topic. |
| CD or DVD disc is dirty. | Clean CD or DVD with a CD cleaning kit, available from most computer stores. |
| Windows does not detect the CD-ROM or DVD-ROM drive. | <ol style="list-style-type: none">1. Use Device Manager to remove or uninstall the device.2. Restart the computer and let Windows detect the CD or DVD driver. |

Recording or copying CDs is difficult or impossible.

| Cause | Solution |
|-----------------------------------|-----------------------------------------------------------------------------------------------------------------------------------------------------------------------------------------------------------------------------------------------------------|
| Wrong or poor quality media type. | <ol style="list-style-type: none">1. Try using a slower speed when recording.2. Verify that you are using the correct media for the drive.3. Try a different brand of media. Quality varies widely between manufacturers. |

Solving USB Flash Drive Problems

If you encounter USB flash drive problems, common causes and solutions are listed in the following table.

Table B-16 Solving USB Flash Drive Problems

USB flash drive is not seen as a drive letter in Windows.

| Cause | Solution |
|------------------------------------------------------------------|-----------------------------------------------------------------|
| The drive letter after the last physical drive is not available. | Change the default drive letter for the flash drive in Windows. |

USB flash drive not found (identified).

| Cause | Solution |
|------------------------------------------------------------------------------|-----------------------------------------------------------------------------------------------------------------------------------------------------------------------|
| The device is attached to a USB port that has been hidden in Computer Setup. | Run the Computer Setup utility and ensure that "Device available" is selected for "Front USB Ports" and "Rear USB Ports" under Security > Device Security . |
| The device was not properly seated before power-up. | Ensure the device is fully inserted into the USB port before applying power to the system |

System will not boot from USB flash drive.

| Cause | Solution |
|-----------------------------------------------------------------|-------------------------------------------------------------------------------------------------------------------------------------------------------------------------|
| Boot order is not correct. | Run the Computer Setup utility and change boot sequence in Storage > Boot Order . |
| Removable Media Boot is disabled in the Computer Setup utility. | Run the Computer Setup utility and enable booting to removable media in Storage > Storage Options . Ensure USB is enabled in Storage > Boot Order . |

The computer boots to DOS after making a bootable flash drive.

| Cause | Solution |
|--------------------------|----------------------------------------------------------------|
| Flash drive is bootable. | Install the flash drive only after the operating system boots. |

Solving Internet Access Problems

If you encounter Internet access problems, consult your Internet Service Provider (ISP) or refer to the common causes and solutions listed in the following table.

Table B-17 Solving Internet Access Problems

| Unable to connect to the Internet. | |
|--------------------------------------------------------------------------------|----------------------------------------------------------------------------------------------------------------------------------------------------------------------------------------|
| Cause | Solution |
| Internet Service Provider (ISP) account is not set up properly. | Verify Internet settings or contact your ISP for assistance. |
| Modem is not set up properly. | Reconnect the modem. Verify the connections are correct using the quick setup documentation. |
| Web browser is not set up properly. | Verify that the Web browser is installed and set up to work with your ISP. |
| Cable/DSL modem is not plugged in. | Plug in cable/DSL modem. You should see a "power" LED light on the front of the cable/DSL modem. |
| Cable/DSL service is not available or has been interrupted due to bad weather. | Try connecting to the Internet at a later time or contact your ISP. (If the cable/DSL service is connected, the "cable" LED light on the front of the cable/DSL modem will be on.) |
| The CAT5 UTP cable is disconnected. | Connect the CAT5 UTP cable between the cable modem and the computer's RJ-45 connector. (If the connection is good, the "PC" LED light on the front of the cable/DSL modem will be on.) |

Table B-17 Solving Internet Access Problems (continued)

Unable to connect to the Internet.

| Cause | Solution |
|----------------------------------------------------------------------------------------------------------------------------------------------------------------------------------------------------------------------------------------------------|----------------------------------------------------------------------------------------------------------------------------------------------------------------------------------------------------------------------------------------------------------------------------------------------------------------------------------------------------------------------------------------------------------------------------------------------------------------------------------------------------------------------------------------------------------------------------------------------------------------------------------------------------------------------------------------------------------------------------------------------------------------------------------------------------------------------------------------------------------------------------------------------------------------------------------------------------------------------------------------------------------------------------------------------|
| IP address is not configured properly. | Contact your ISP for the correct IP address. |
| Cookies are corrupted. (A “cookie” is a small piece of information that a Web server can store temporarily with the Web browser. This is useful for having the browser remember some specific information that the Web server can later retrieve.) | <p>Windows 7</p> <ol style="list-style-type: none">1. Select Start > Control Panel.2. Click Network and Internet.3. Click Internet Options.4. In the Browsing history section on the General tab, click the Delete button.5. Select the Cookies check box and click the Delete button. <p>Windows Vista</p> <ol style="list-style-type: none">1. Select Start > Control Panel.2. Click Network and Internet.3. Click Internet Options.4. In the Browsing history section on the General tab, click the Delete button.5. Click the Delete cookies button. <p>Windows XP</p> <ol style="list-style-type: none">1. Select Start > Control Panel.2. Double-click Internet Options.3. On the General tab, click the Delete Cookies button. |

Cannot automatically launch Internet programs.

| Cause | Solution |
|--------------------------------------------------------------|----------------------------------------------------|
| You must log on to your ISP before some programs will start. | Log on to your ISP and launch the desired program. |

Internet takes too long to download Web sites.

| Cause | Solution |
|-------------------------------|------------------------------------------------------------------------------------------------------------------------------------------------------------------------------------------------------------------------------------------------------------------------------------------------------------------------------------------------------------------------------------------------------------------------------------------------------------------------------------------------------------------------------------------------------------------------------------------------------------------------------------------------------------------------------------------------------------------------------------------------------------------------------------------------------------------------------------------------------------------------------------------------------------------------------------------------------------------------------------------------------------------------------------------------------------------------------------------------------------------------------------------------------------------------------------------------------------------------------------------------------------------------------------------------------------------------------------------------------------------------------------------------------------------------------------------------------------------------------------------------------------------------------------------------------------------------------------------------------------------------------------------------------------------------------------------------------------------------------------------------------------------------------------------------------------------------------------------------------------------------------------------------------------------------------------------------------------------|
| Modem is not set up properly. | <p data-bbox="861 279 1469 331">Verify that the modem is connected and communicating properly.</p> <p data-bbox="861 352 989 373">Windows 7</p> <ol data-bbox="861 405 1469 783" style="list-style-type: none">1. Select Start > Control Panel.2. Click on Hardware and Sound.3. Click on Device Manager.4. Double-click Modems.5. Double-click Agere Systems PCI-SV92PP Soft Modem.6. On the General tab, click Diagnostics.7. Click Query Modem. A “Success” response indicates the modem is connected and working properly. <p data-bbox="861 814 1005 835">Windows XP</p> <ol data-bbox="861 867 1469 1318" style="list-style-type: none">1. Select Start > Control Panel.2. Double-click System.3. Click the Hardware tab.4. In the Device Manager area, click the Device Manager button.5. Double-click Modems.6. Double-click Agere Systems PCI-SV92PP Soft Modem.7. On the General tab, click Diagnostics.8. Click Query Modem. A “Success” response indicates the modem is connected and working properly. <p data-bbox="861 1350 1029 1371">Windows Vista</p> <ol data-bbox="861 1402 1469 1812" style="list-style-type: none">1. Select Start > Control Panel.2. Click on System and Maintenance.3. Click on System.4. In the Tasks list, select Device Manager.5. Double-click Modems.6. Double-click Agere Systems PCI-SV92PP Soft Modem.7. On the General tab, click Diagnostics.8. Click Query Modem. A “Success” response indicates the modem is connected and working properly. |

Solving Software Problems

Most software problems occur as a result of the following:

- The application was not installed or configured correctly.
- There is insufficient memory available to run the application.
- There is a conflict between applications.
- Be sure that all the needed device drivers have been installed.
- If you have installed an operating system other than the factory-installed operating system, check to be sure it is supported on the system.

If you encounter software problems, see the applicable solutions listed in the following table.

Table B-18 Solving Software Problems

Computer will not continue and no HP logo screen has appeared.

| Cause | Solution |
|--------------------------|-----------------------------------------------------------------------------------------------------------------------------------------------------------------------------------------------------------------------------------------------------|
| POST error has occurred. | Observe the beeps and LED lights on the front of the computer. See Appendix A, POST Error Messages on page 102 to determine possible causes. See the Restore Kit or the Worldwide Limited Warranty for terms and conditions. |

Computer will not continue after HP logo screen has appeared.

| Cause | Solution |
|------------------------------|------------------------------------------------------|
| System files may be damaged. | Use recovery diskette to scan hard drive for errors. |

“Illegal Operation has Occurred” error message is displayed.

| Cause | Solution |
|-----------------------------------------------------------------------------|------------------------------------------------------------------------------------------------------------------------------|
| Software being used is not Microsoft-certified for your version of Windows. | Verify that the software is certified by Microsoft for your version of Windows (see program packaging for this information). |
| Configuration files are corrupt. | If possible, save all data, close all programs, and restart the computer. |

Contacting Customer Support

For help and service, contact an authorized reseller or dealer. To locate a reseller or dealer near you, visit <http://www.hp.com>.



NOTE: If you take the computer to an authorized reseller, dealer, or service provider for service, remember to provide the setup and power-on passwords if they are set.

Refer to the number listed in the warranty or in the *Support Telephone Numbers* guide for technical assistance.



C Connector Pin Assignments

This appendix contains the pin assignments for many computer and workstation connectors. Some of these connectors may not be used on the product being serviced.

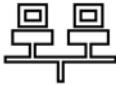
Ethernet BNC

| Connector and Icon | Pin | Signal |
|-----------------------------------------------------------------------------------|-----|--------|
|  | 1 | Data |
|  | 2 | Ground |

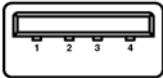
USB

| Connector and Icon | Pin | Signal |
|-------------------------------------------------------------------------------------|-----|--------|
|  | 1 | +5 VDC |
|  | 2 | - Data |
| | 3 | + Data |
| | 4 | Ground |

Microphone

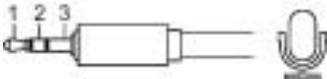
| Connector and Icon (1/8" miniphone) | Pin | Signal |
|-------------------------------------------------------------------------------------|------------|-------------|
|  | 1 (Tip) | Audio_left |
| | 2 (Ring) | Audio_Right |
| | 3 (Shield) | Ground |

Headphone

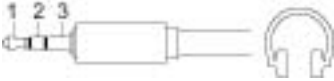
| Connector and Icon (1/8" miniphone) | Pin | Signal |
|-----------------------------------------------------------------------------------|------------|-------------|
|  | 1 (Tip) | Audio_left |
| | 2 (Ring) | Power_Right |
| | 3 (Shield) | Ground |

Line-in Audio

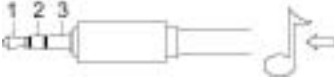
| Connector and Icon (1/8" miniphone) | Pin | Signal |
|-----------------------------------------------------------------------------------|------------|----------------|
|  | 1 (Tip) | Audio_In_Left |
| | 2 (Ring) | Audio_In_Right |
| | 3 (Shield) | Ground |

Line-out Audio

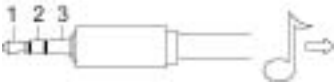
| Connector and Icon (1/8" miniphone) | Pin | Signal |
|-------------------------------------------------------------------------------------|------------|-----------------|
|  | 1 (Tip) | Audio_Out_Left |
| | 2 (Ring) | Audio_Out_Right |
| | 3 (Shield) | Ground |

D Power Cord Set Requirements

The power supplies on some computers have external power switches. The voltage select switch feature on the computer permits it to operate from any line voltage between 100-120 or 220-240 volts AC. Power supplies on those computers that do not have external power switches are equipped with internal switches that sense the incoming voltage and automatically switch to the proper voltage.

The power cord set received with the computer meets the requirements for use in the country where you purchased the equipment.

Power cord sets for use in other countries must meet the requirements of the country where you use the computer.

General Requirements

The requirements listed below are applicable to all countries:

1. The power cord must be approved by an acceptable accredited agency responsible for evaluation in the country where the power cord set will be installed.
2. The power cord set must have a minimum current capacity of 10A (7A Japan only) and a nominal voltage rating of 125 or 250 volts AC, as required by each country's power system.
3. The diameter of the wire must be a minimum of 0.75 mm₂ or 18AWG, and the length of the cord must be between 1.8 m (6 feet) and 3.6 m (12 feet).

The power cord should be routed so that it is not likely to be walked on or pinched by items placed upon it or against it. Particular attention should be paid to the plug, electrical outlet, and the point where the cord exits from the product.

 **WARNING!** Do not operate this product with a damaged power cord set. If the power cord set is damaged in any manner, replace it immediately.

Japanese Power Cord Requirements

For use in Japan, use only the power cord received with this product.

 **CAUTION:** Do not use the power cord received with this product on any other products.

Country-Specific Requirements

Additional requirements specific to a country are shown in parentheses and explained below.

| Country | Accrediting Agency | Country | Accrediting Agency |
|---------------|--------------------|--------------------|--------------------|
| Australia (1) | EANSW | Italy (1) | IMQ |
| Austria (1) | OVE | Japan (3) | METI |
| Belgium (1) | CEBC | Norway (1) | NEMKO |
| Canada (2) | CSA | Sweden (1) | SEMKO |
| Denmark (1) | DEMKO | Switzerland (1) | SEV |
| Finland (1) | SETI | United Kingdom (1) | BSI |
| France (1) | UTE | United States (2) | UL |
| Germany (1) | VDE | | |

1. The flexible cord must be Type HO5VV-F, 3-conductor, 0.75mm² conductor size. Power cord set fittings (appliance coupler and wall plug) must bear the certification mark of the agency responsible for evaluation in the country where it will be used.
2. The flexible cord must be Type SVT or equivalent, No. 18 AWG, 3-conductor. The wall plug must be a two-pole grounding type with a NEMA 5-15P (15A, 125V) or NEMA 6-15P (15A, 250V) configuration.
3. Appliance coupler, flexible cord, and wall plug must bear a "T" mark and registration number in accordance with the Japanese Dentori Law. Flexible cord must be Type VCT or VCTF, 3-conductor, 0.75 mm² conductor size. Wall plug must be a two-pole grounding type with a Japanese Industrial Standard C8303 (7A, 125V) configuration.

E Specifications

All-in One Models

Table E-1 Specifications

| Dimensions (with stand) | | |
|-------------------------------------------|----------------|----------------|
| Height | 17.7 in | 45.0 cm |
| Width | 23.0 in | 58.5 cm |
| Depth | 4.1 in | 10.0 cm |
| Dimensions (without stand) | | |
| Height | 16.0 in | 40.5 cm |
| Width | 23.0 in | 58.5 cm |
| Depth | 3.8 in | 9.6 cm |
| Approximate Weight (with stand) | | |
| Integrated graphics | 26.0 lb | 11.8 kg |
| Discrete graphics | 26.7 lb | 12.1 kg |
| Approximate Weight (without stand) | | |
| Integrated graphics | 19.2 lb | 8.7 kg |
| Discrete graphics | 20.0 lb | 9.1 kg |
| Temperature Range | | |
| Operating | 41° to 95°F | 5° to 35°C |
| Nonoperating | -22° to 149°F | -30° to 66°C |
| Relative Humidity (noncondensing) | | |
| Operating | 15-80% at 79°F | 15-80% at 26°C |
| Maximum Altitude (unpressurized) | | |
| Operating | 0 - 6,562 ft | 0 - 2000 m |
| Nonoperating | 0 - 15,000 ft | 4,572 m |

Table E-1 Specifications (continued)

| Power Supply | | |
|--------------------------------|------------------------------------------------|---------------------------|
| Rated Voltage Range | 100-240 V | 100-240 V |
| Rated Line Frequency | 50-60 Hz | 50-60 Hz |
| Max Operating Power | | |
| Integrated graphics | < 230 W | < 230 W |
| Discrete graphics | <180 W | <180 W |
| Average Operating Power | | |
| | Integrated graphics: 58 W | Integrated graphics: 58 W |
| | Discrete graphics: 66 W | Discrete graphics: 66 W |
| Display | | |
| Resolution | 1920 x 1080 resolution (16:9), Full HD (1080p) | |
| Contrast ratio | 1000:1 | |
| Image brightness | 250 nits typical | |
| Vertical viewing angle | 178 degrees | |
| Horizontal viewing angle | 178 degrees | |

Index

- A**
 - AC adapter
 - spare part numbers 27, 31, 32
 - audible codes 110
 - audio problems 129
- B**
 - battery
 - disposal 25
 - beep codes 110
 - boards, spare part numbers 29
 - booting options
 - Full Boot 102
 - Quick Boot 102
- C**
 - cable pinouts
 - SATA data 17
 - cables, spare part numbers 30
 - cautions
 - AC power 19
 - cables 25
 - electrostatic discharge 20
 - keyboard cleaning 23
 - keyboard keys 24
 - CD-ROM or DVD problems 142
 - cleaning
 - computer 23
 - mouse 24
 - safety precautions 23
 - computer cleaning 23
 - connector pin assignments 150
 - country power cord set requirements 153
 - Customer Support 149
- D**
 - diskette problems 118
- display panel
 - removing 98
 - spare part numbers 26, 32, 98
- DisplayPort to HDMI cable
 - spare part number 30, 31
- E**
 - electrostatic discharge (ESD) 20
 - preventing damage 20
 - error
 - codes 102, 110
 - messages 103
 - ethernet
 - BNC pin assignments 150
- F**
 - fan
 - removing 83
 - spare part number 26, 32, 83
 - fan sink assembly
 - spare part number 26
 - features
 - front components 3
 - rear components 5
 - side components 4
 - FFC I/O cable
 - spare part number 30, 32
 - flash drive problems 144
 - flashing LEDs 110
- G**
 - G-sensor board
 - removing 100
 - spare part number 29, 32, 100
 - G-sensor cable
 - spare part number 30, 32, 100
 - general problems 114
- graphics board
 - removing 91
- graphics card
 - spare part numbers 29, 31
- grounding methods 21
- H**
 - hard drive
 - proper handling 25
 - removing 54, 89
 - SATA characteristics 17
 - spare part numbers 27
 - hard drive problems 121
 - hardware installation problems 134
 - headphone pin assignments 151
 - heat sink
 - removing 85
 - heat sink assembly
 - spare part number 32
- I**
 - infrared sensor board
 - removing 81
 - spare part number 29, 32, 81
 - installing
 - memory 50
 - Internet access problems 145
 - inverter
 - spare part numbers 29, 32, 57
 - inverter board
 - removing 57
 - IR blaster cable
 - spare part number 30, 31
- K**
 - keyboard
 - cleaning 23
 - spare part numbers 28

keyboard problems 132

L

LEDs

blinking power 110

blinking PS/2 keyboard 110

left cap

removing 61

left side cap

spare part number 27, 32, 33

spare part numbers 61

line-in audio pin assignments

151

line-out audio pin assignments

151

M

main rear frame

removing 75

Media Card Reader problems

124

memory

installing 50

populating sockets 51

removing 52

specifications 50

memory module

spare part numbers 27, 31

memory problems 140

microphone pin assignments 150

monitor problems 126

mouse

cleaning 24

spare part numbers 28

mouse problems 132

N

network problems 136

NTSC cable

spare part number 30, 33

numeric error codes 103

O

opening the computer 34

operating guidelines 22

optical drive

removing 63

spare part numbers 26

optical drive connector board

removing 59

spare part number 29, 32

spare part numbers 59

optical drive eject board

removing 65

spare part number 29, 32

spare part numbers 65

optical drive eject cable

spare part number 30, 32, 65

optical drive problems 142

optical drive transfer cable

spare part number 30, 32, 59

overheating, prevention 22

P

POST error messages 102

power board

spare part number 29, 32, 76

power button board

removing 76

power cord set requirements

country specific 153

power problems 117

power supply 155

printer problems 131

problems

audio 129

CD-ROM or DVD 142

diskette 118

flash drive 144

general 114

hard drive 121

hardware installation 134

Internet access 145

keyboard 132

Media Card Reader 124

memory 140

monitor 126

mouse 132

network 136

power 117

printer 131

processor 141

software 148

processor

removal and replacement

procedures 86

spare part numbers 27

processor problems 141

R

rear logo cover

removing 72

rear panels

removing 47

remote control

spare part numbers 31

remote controls

spare part numbers 28

removal and replacement

processor 86

removal and replacement

procedures 34

display panel 98

fan 83

fan sink 85

G-sensor board 100

graphics board 91

hard drive 54

hard drive connector 89

infrared sensor board 81

inverter board 57

left cap 61

main rear frame 75

optical drive 63

optical drive connector board

59

optical drive eject board 65

power button board 76

preparing to disassemble the

computer 34

rear logo cover 72

rear panels 47

right cap 67

speakers 79

stand 35

system board 96

system board shield 77

thermal module 85

TV tuner module 93

VESA mount 37

volume board 70

webcam module 73

WLAN module 93

right cap

removing 67

right side cap

spare part number 28, 33, 67

S

- safety and comfort 113
- safety precautions
 - cleaning 23
- SATA
 - connectors on system board 17
 - data cable pinouts 17
 - hard drive characteristics 17
- screws, correct size 24
- sensor2 cable
 - spare part number 30, 32
- service considerations 24
- software
 - problems 148
 - servicing computer 24
- spare part number
 - tamper-resistant wrench 24
 - Torx T-15 screwdriver 24
- speakers
 - removing 79
 - spare part numbers 26, 31, 79
- specifications
 - computer 154
 - memory 50
- stand
 - removing 35
- static electricity 20
- system board
 - removing 96
 - SATA connectors 17
 - spare part numbers 26, 32
- system board shield
 - removing 77

T

- tamper-proof screws
 - tool 24
- temperature control 22
- thermal module
 - removing 85
- thermal module, spare part number 26, 32
- tools, servicing 24
- Torx T15 screwdriver 24
- TV tuner module
 - removing 93
 - spare part number 29, 31

U

- UMA I/O-DataPort cable
 - spare part number 30
- UMA I/O-System board cable
 - spare part number 30
- USB pin assignments 150

V

- ventilation, proper 22
- VESA mount
 - installing 37
- volume button board
 - removing 70
 - spare part number 29, 32, 70

W

- Wake-on-LAN feature 136
- webcam module
 - removing 73
 - spare part number 30, 32
- WLAN module
 - removing 93
 - spare part number 29