



**Kodak**

# i1400 Series Scanners

## User's Guide

User's Guide on Installation CD  
Guides de l'utilisateur sur le CD d'installation  
Benutzerhandbücher auf der Installations-CD  
Guida dell'utente sul CD di installazione  
Guías de usuario incluidas en el CD de instalación  
Guias do usuário no CD de instalação  
Gebruikershandleidingen op installatie-cd  
Kurulum CD'sindeki Kullanım Kılavuzları  
Uživatelská příručka na instalačním disku CD  
使用指南在安裝光碟中  
使用手冊在安裝光碟片中  
インストーションCDに含まれるユーザーガイド  
설치 CD의 사용 설명서  
Руководство пользователя на установочном компакт-диске

**OVERVIEW** 1-1

**INSTALLATION** 2-1

**SCANNING** 3-1

**DOCUMENT PRINTING** 4-1

**MAINTENANCE** 5-1

**TROUBLESHOOTING** 6-1

# Safety

---

## User Precautions

- Place the scanner on a sturdy, level work surface capable of supporting 5.5 kg (12 lbs).
- Do not install the scanner in a location subject to dust, humidity or steam. This may cause electrical shock or a fire. Only use the scanner and power supply indoors in a dry location.
- Make sure the electrical power outlet is located within 1.52 meters (5 feet) of the scanner and is easily accessible.
- Use only the power supply that was provided with the scanner. Using any other power cord may cause electrical shock and/or damage the product.
- The printer access door must be in place and closed during scanner operation, except when changing the print head location or replacing the ink cartridge. When the printer access door is removed, **do not** allow loose clothing, jewelry, hair or other objects to enter the printer opening.
- Be sure the power cord is securely plugged into the wall outlet. Failure to do so may cause electrical shock or fire.
- Do not damage, knot, cut or modify the power cord. This may cause electrical shock or fire.
- The scanner requires a dedicated power outlet. Do not use an extension cord or power strip with the scanner.
- Leave sufficient space around the power outlet so it can be easily unplugged in case of an emergency.
- Do not use the scanner if it becomes inordinately hot, has a strange odor, emits smoke, or makes unfamiliar noises. Immediately stop the scanner and disconnect the power cord from the power outlet. Contact Kodak Service.
- Do not disassemble or modify the scanner or the AC power adapter.
- This product is designed for connection to IT power systems.
- Do not move the scanner with the power cord and interface cable attached. This may cause damage to the cord/cable. Remove the power cord from the wall outlet before moving the scanner.
- Follow the Kodak recommended cleaning procedures. Do not use air, liquid or gas spray cleaners. These cleaners displace dust, dirt and debris to another location within the scanner, which may cause the scanner to malfunction.
- Material Safety Data Sheets (MSDS) for chemical products are available on the Kodak website at: [www.kodak.com/go/msds](http://www.kodak.com/go/msds). When accessing the MSDSs from the website, you will be required to provide the catalog number of the consumable you want the Material Safety Data Sheet for. See the section entitled, "Supplies and consumables" later in this guide for supplies and catalog numbers.

Users and their employer need to observe the common sense precautions applicable to the operation of any machinery. These include, but are not limited to, the following:

- Do not wear loose clothing, unbuttoned sleeves, etc.
- Do not wear loose jewelry, bracelets, bulky rings, long necklaces, etc.
- Hair length should be kept short, using a hair net if needed, or tying long hair up in a bundle.
- Remove all other loose objects from the area that could be drawn into the machine.
- Take sufficient breaks to maintain mental alertness.
- Use only the recommended cleaning supplies.
- Do not use canned/compressed air.

Supervisors should review their practices and make compliance with these precautions a part of the job description for operation of the scanner or any mechanical device.

## Warning labels



**CAUTION: Moving parts, avoid contact.**



**CAUTION: Hot surface, avoid contact.**

## Environmental information

- The *Kodak i1400 Series Scanners* are designed to meet worldwide environmental requirements.
- Guidelines are available for the disposal of consumable items that are replaced during maintenance or service; follow local regulations or contact Kodak locally for more information.
- The product packaging is recyclable.
- *Kodak i1400 Series Scanners* are Energy Star compliant and shipped from the factory with the default time set to 15 minutes.

## European Union



This symbol indicates that when the last user wishes to discard this product, it must be sent to appropriate facilities for recovery and recycling. Please contact your local Kodak representative or refer to [www.kodak.com/go/recycle](http://www.kodak.com/go/recycle) for additional information on the collection and recovery programs available for this product.

Please consult [www.kodak.com/go/REACH](http://www.kodak.com/go/REACH) for information about the presence of substances included on the candidate list according to article 59(1) of Regulation (EC) No. 1907/2006 (REACH).

## Acoustic emission

Maschinenlärminformationsverordnung – 3, GSGV  
Der arbeitsplatzbezogene Emissionswert beträgt <70 dB(A).

[Machine Noise Information Ordinance — 3, GSGV  
The operator-position noise emission value is <70 dB(A).]

## EMC statements

**United States:** This equipment has been tested and found to comply with the limits for a Class B digital device pursuant to Part 15 of the FCC rules. These limits are designed to provide reasonable protection against harmful interference in a residential installation. This equipment generates, uses, and can radiate radio frequency energy and, if not installed and used in accordance with the instruction manual, may cause harmful interference to radio communications. However, there is no guarantee that interference will not occur in a particular installation. If this equipment does cause harmful interference to radio or television reception, which can be determined by turning the equipment off and on, the user is encouraged to try to correct the interference by one or more of the following measures:

- Reorient or relocate the receiving antenna.
- Increase the separation between the equipment and receiver.
- Connect the equipment into an outlet on a circuit different from that to which the receiver is connected.
- Consult the dealer or an experienced radio/TV technician for additional suggestions.

Any changes or modifications not expressly approved by the party responsible for compliance could void the user's authority to operate the equipment. Where shielded interface cables have been provided with the product or specified additional components or accessories elsewhere defined to be used with the installation of the product, they must be used in order to ensure compliance with FCC regulation.

**Korea:** As this equipment has obtained EMC registration for household use, it can be used in an area including residential areas.

이 기기는 가정용으로 전자파적합등록을 한 기기로서 주거지역에서는 물론 모든 지역에서 사용할 수 있습니다.

**Japan:** This is a Class B product based on the standard of the Voluntary Control Council for interference by information Technology Equipment (VCCI). If this is used near a radio or television receiver in a domestic environment, it may cause radio interference. Install and use the equipment according to the instruction manual.

この装置は、情報処理装置等電波障害自主規制協議会（VCCI）の基準に基づきクラスB情報技術装置です。この装置は、家庭環境で使用することを目的としていますが、この装置がラジオやテレビジョン受信機に近接して使用されると、受信障害を引き起こすことがあります。  
取扱説明書に従って正しい取り扱いをして下さい。

# 1 Overview

---

## Contents

Supporting documentation .....	1-1
Accessories.....	1-2
What's in the box .....	1-2
Scanner components .....	1-3

The *Kodak i1400 Series Scanners* include the following models:



**Kodak i1405 Scanner** — desktop duplex color scanner that scans up to 45 ppm (300 dpi, black and white, landscape orientation) letter-size documents.

**Kodak i1410 Scanner** — desktop simplex color scanner that scans up to 60 ppm (300 dpi, black and white, landscape orientation) letter-size documents.

**Kodak i1420 Scanner** — desktop duplex color scanner that scans up to 60 ppm (300 dpi, black and white, landscape orientation) letter-size documents.

**Kodak i1440 Scanner** — desktop duplex color scanner that scans up to 75 ppm (300 dpi, black and white, landscape orientation) letter-size documents.

This User's Guide provides information and procedures for using and maintaining the *Kodak i1400 Series Scanners*. The information in this guide is for use with all scanner models unless otherwise noted.

## Supporting documentation

In addition to this User's Guide, the following documentation is also available:

- **Installation Guide** — provides a step-by-step procedure for installing the scanner.
- **Image Processing Guide** — the TWAIN Datasource and ISIS Driver are included with the *Kodak i1400 Series Scanners*. The Image Processing Guide explains how to use basic image processing features and is provided on the Installation CD in PDF format.
- **Smart Touch User's Guide** — provides information and procedures on how to use Smart Touch functionality. This guide is provided on the Installation CD in PDF format.
- **Reference Guide** — provides easy visual steps for cleaning your scanner. Keep this guide close to the scanner so you can use it as an easy reference.

## Accessories

- **Kodak A4 Flatbed Accessory** — the *Kodak A4 Flatbed* adds scanning capability for exception documents up to 8.5 x 11-inch (A4) size paper to your *Kodak i1400 Series Scanner*.  
CAT No. 867 7288
- **Kodak Black Background Accessory for A4 Flatbed** — this flatbed cover can be used if you are scanning documents with primarily a white background and you want a defined black border on your images. CAT No. 863 6870
- **Kodak A3 Flatbed Accessory** — the *Kodak A3 Flatbed* adds scanning capability for exception documents up to 11 x 17-inch (A3) size paper to your *Kodak i1400 Series Scanner*.  
CAT No. 179 6747

NOTE: The Flatbed Accessories listed above are not available for the *Kodak i1405 Scanner*.

## What's in the box

Before you begin open the box and check the contents:

- *Kodak i1405, i1410, i1420 or i1440 Scanner*
- Input tray
- Output tray
- USB 2.0 cable
- Power supply
- AC power cord bundles
- Welcome Folio which includes:
  - Installation CD
  - Application CDs
  - Warranty/Registration sheets
  - Printed User's Guide, English
  - Reference Guide
  - Installation Guide
  - Service & Support Contact Information sheets
  - Miscellaneous flyers

# Scanner components

## Front view

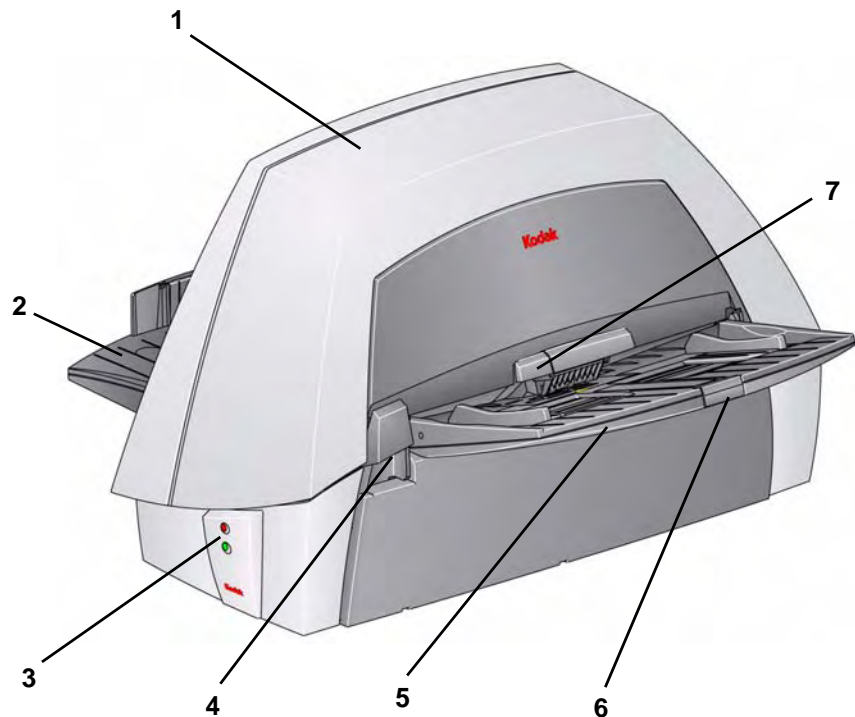

- 1 **Scanner cover** — provides access to the internal components.
- 2 **Output tray** — collects the scanned documents.
- 3 **LEDs** — illuminates and flashes indicating scanner status.
- 4 **Scanner cover release lever** — push up to open the scanner cover.
- 5 **Input tray** — holds up to 100 documents (20 lb/75 g/m<sup>2</sup>) in place.
- 6 **Input tray extender** — pull this extender out when scanning documents longer than 21.6 x 27.9 cm (8.5 x 11 inches).
- 7 **Gap release lever** — push up to adjust the space between the feed module and separator module for documents that require special handling.

## Inside view

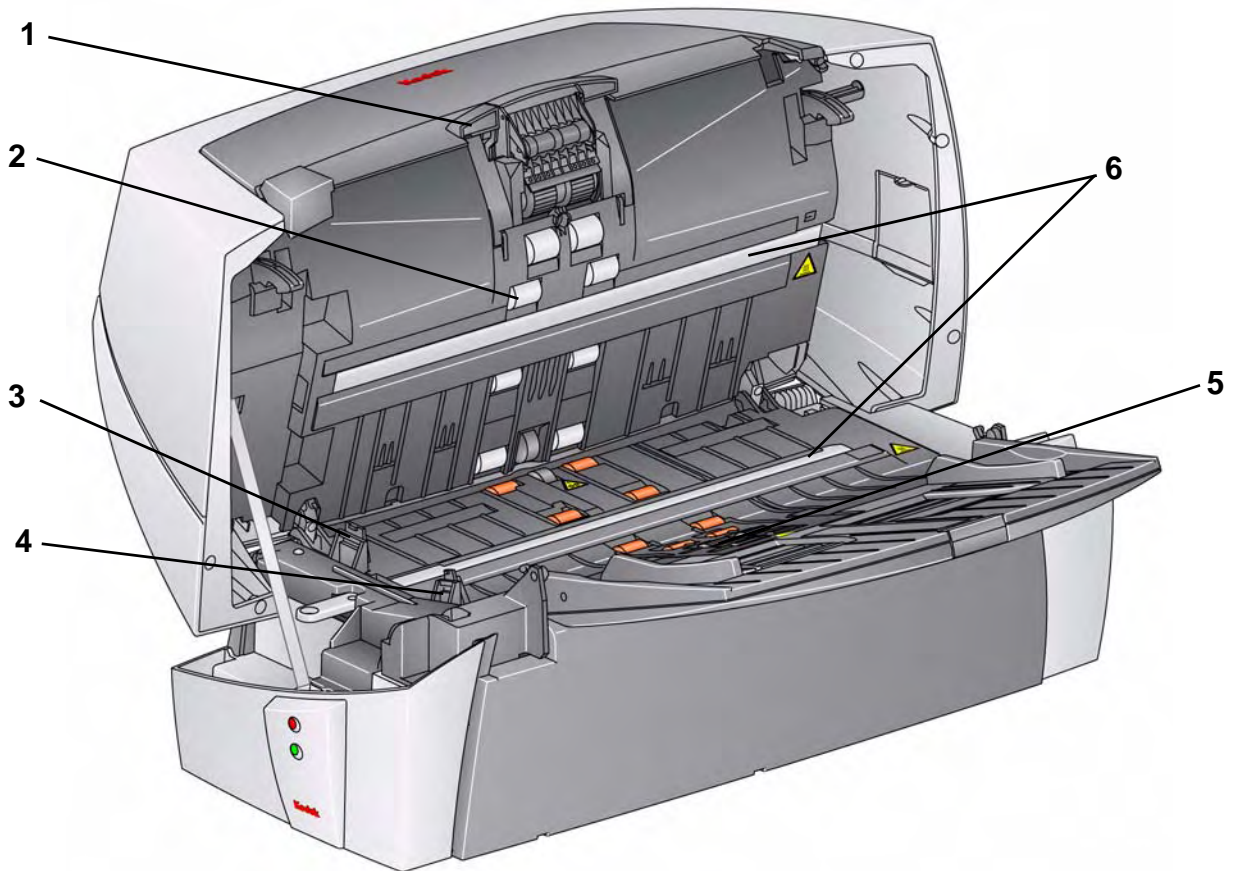

- 1 **Separator module** — provides smooth document feeding and separation of various sizes, thicknesses and textures of documents.
- 2 **Rollers** — provides smooth transport of documents through the scanner.
- 3 **Rear roller cover** — provides access to the rear rollers for cleaning.
- 4 **Front roller cover** — provides access to the feed module. This cover needs to be removed when cleaning or replacing the feed module or feed module tires.
- 5 **Feed module** — provides smooth document feeding and separation of various sizes, thicknesses and textures of documents.
- 6 **Imaging guides** — keep imaging guides clean to obtain optimum image quality.

NOTE: The *Kodak i1410* Scanner does not have an upper imaging guide.



## Side views

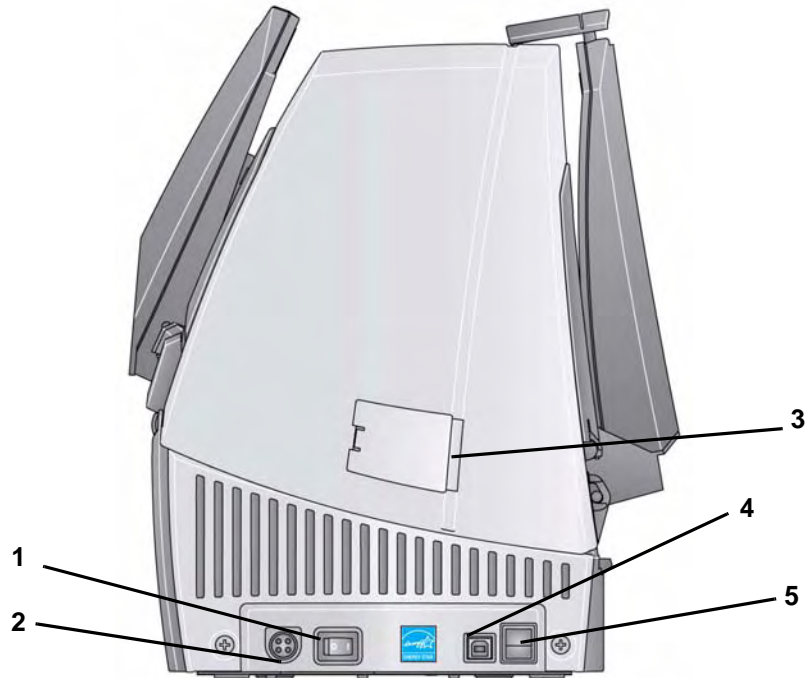

- 1 **Power button** — turns the power to the scanner on (I) and off (O).
- 2 **Power port** — connects the power cord to the scanner.
- 3 **Side access door** — provides access to the upper imaging guide for replacement. *The **Kodak i1410 Scanner** does not have a side access door.*
- 4 **USB port** — connects the scanner to the PC.
- 5 **Flatbed/USB port** — connects the optional A4 or A3 Flatbed to the scanner.

NOTE: The Flatbed/USB port is not available on the i1405 Scanner.



- 6 **Top LED** — flashes red when an error is encountered.
- 7 **Bottom LED** — steady green when the scanner is ready to scan; flashes green when the scanner is preparing to scan.

# 2 Installation

---

## Contents

Installing the scanner .....	2-1
Installing the <i>Kodak</i> Driver Software - Windows .....	2-1
Attaching the input and output trays .....	2-3
Connecting the power cord and USB cable .....	2-4
Disconnecting the power cord.....	2-4
Turning on the scanner .....	2-5

## Installing the scanner

This section provides detailed information of the *Installation Guide* that is provided with your scanner. Follow these steps in the order they are provided to install your scanner.

NOTE: If you have already performed all of the steps in the *Installation Guide*, skip this section.

### Installing the *Kodak* Driver Software - Windows operating systems

1. Insert the *Kodak* i1400 Series Scanners Installation CD in the CD-ROM drive. The installation program starts automatically.
2. Select **Install Scanner Software**.



NOTES:

- If the CD does not start automatically, open the My Computer icon on your desktop. Double-click the icon indicating your CD-ROM drive, then double-click on **setup.exe**.
  - If the message ***Portions of this application are already installed*** is displayed, click **Yes** to continue the installation process. Any previously installed *Kodak* Scanner software that is shared with this scanner will be updated.
3. Click **Next** when the Welcome screen is displayed.
  4. Click **I Agree** after you have read and agreed with the terms of the Software License Agreement. The installation will start and several progress screens will be displayed.
  5. Click **Finish** when the installation is complete.
  6. Remove the Installation CD from the CD-ROM drive.

## Attaching the input and output trays

The input and output trays snap into place. The input and output trays can also be adjusted to fit different document sizes.

### Attaching the input tray

1. Locate the input tray slots on the scanner.
2. Align the input tray pins with the slots.

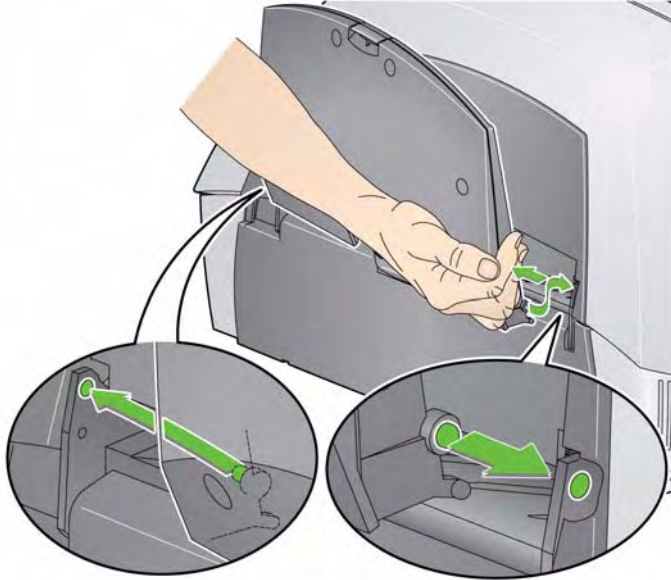

3. Snap the input tray into place.

### Attaching the output tray

1. Locate the output tray slots on the scanner and align the output tray pins with the slots.

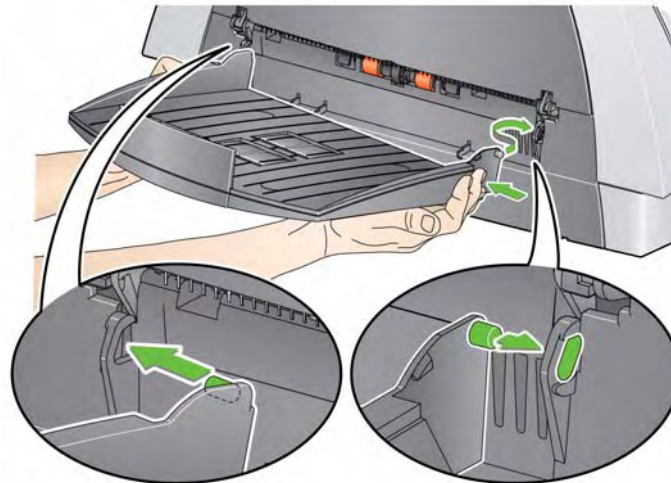

2. Snap the output tray into place.

## Connecting the power cord and USB cable

When the scanner software drivers have finished being installed, connect the power supply, power cord and USB cable to the scanner. Refer to the illustration below for making proper connections. Make sure the power outlet is located within 1.52 metres (5 feet) of the scanner and is easily accessible.

1. Select the appropriate AC power cord for your region from the supply of power cords packed with your scanner.
2. Attach the power cord you selected to the power supply.  
**NOTE:** Be sure that the power cord is securely attached to the power supply.
3. Plug the output power cord from the power supply into the power port on the scanner.
4. Plug the other end of the power cord into the wall outlet.

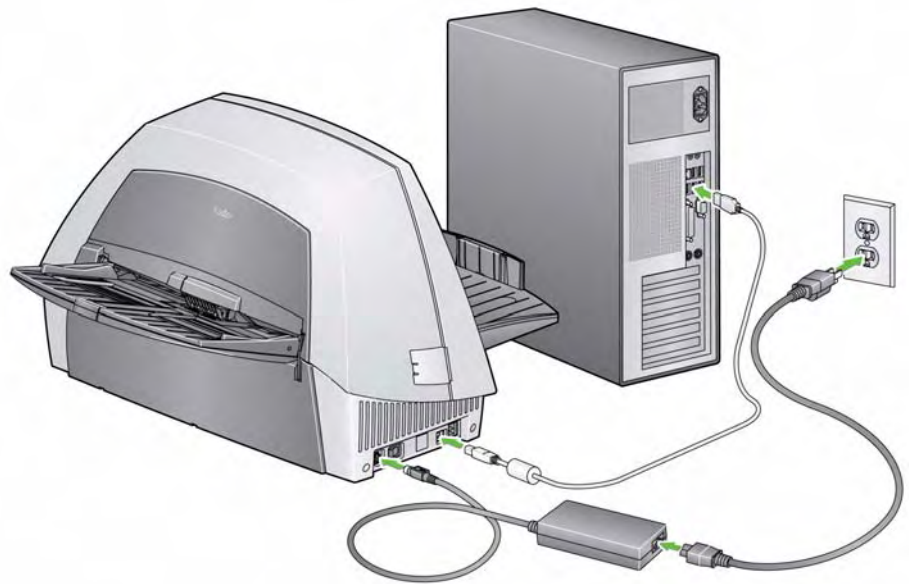

5. Attach the USB cable to the scanner USB port, located on the back of the scanner.
6. Attach the other end of the USB cable to the proper USB port on your PC.

## Disconnecting the power cord

- Place your thumb on the arrow on the collar of the power connector and pull it away from the scanner.

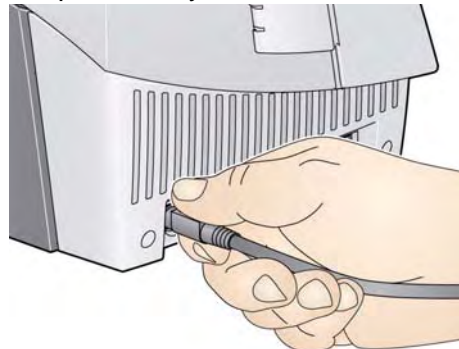

## Turning on the scanner

- Press the button on the back of the scanner to the On (I) position.

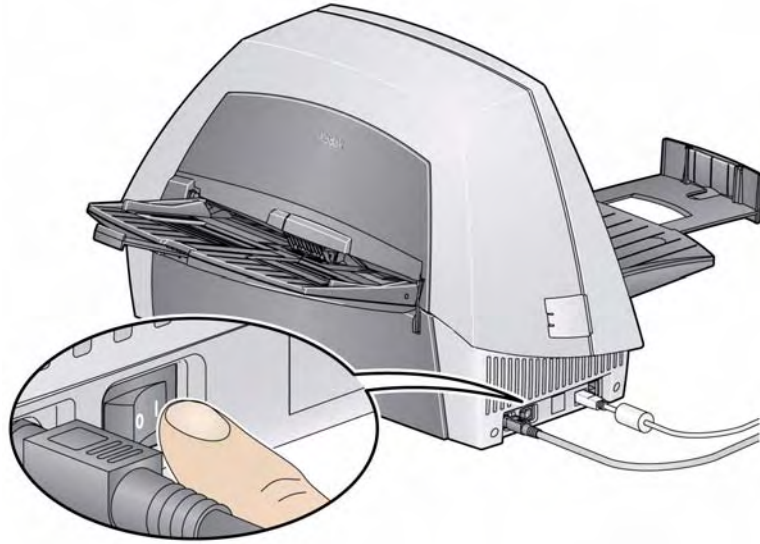

When you turn on the scanner, the green indicator on the side of the scanner will flash as the scanner goes through a series of self tests.

Please wait while the operating system synchronizes the scanner with the installed software.

When the installation process is complete and ready to scan, the LED indicator will stop flashing and stay green.



# 3 Scanning

## Contents

Getting your scanner ready to scan ..... 3-1  
Getting your documents ready to scan ..... 3-3  
Selecting your scanning application ..... 3-4

## Getting your scanner ready to scan

1. Be sure the scanner is on and ready to scan (green indicator light is on and constant).
2. Adjust the output tray to meet your scanning needs.
  - The output tray has three possible positions:



Lowest position for long documents



Middle position for letter or A4 documents



Highest position for checks and small documents

- If you are scanning long documents, grasp the tray extender and pull it out to the desired position.
- The output tray has two document stops that can be raised to accommodate the collection of small documents after they have been scanned.

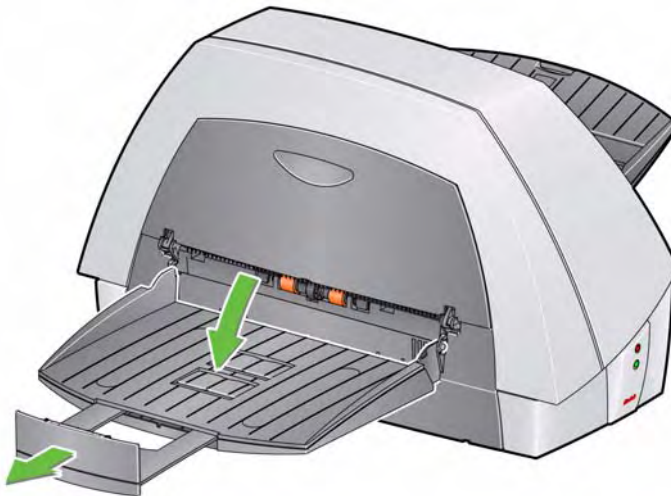

- Adjust the side guides on the input tray (by sliding them in or out) to accommodate the size of documents you are scanning.

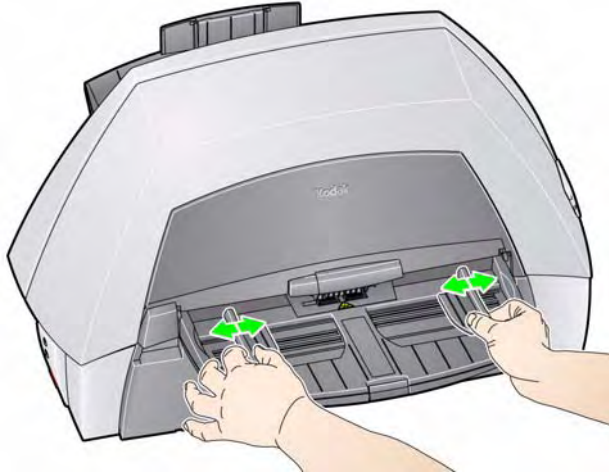

NOTE: When the scanner is not in use, fold the input and output trays flat up against the scanner to save space.





## Getting your documents ready to scan

1. Standard paper size documents feed easily through the scanner. When organizing your documents for scanning, stack the documents so the lead edges are aligned and centered in the input tray. This allows the feeder to introduce documents into the scanner one at a time.
2. Remove all staples and paper clips before scanning. Staples and paper clips on documents may damage the scanner and documents.
3. All inks and correction fluids on the paper must be dry before scanning is started.
4. Torn, damaged or crushed pages can be transported successfully through the scanner. However, no scanner can transport every possible type of damaged paper. If in doubt about whether a damaged document can be transported through the scanner, place the document in a clear protective sleeve. Sleeves should be manually fed, one at a time, folded edge first, while lifting the gap release lever.

NOTE: Scanner models i1410, i1420 and i1440 can also use the optional *Kodak A4 or A3 Flatbed Accessory* for scanning fragile documents.

5. Place the documents you want to scan in the input tray of the scanner. If you are scanning one-sided documents or if you have a *Kodak i1410 Scanner*, be sure the side you want to scan is facing the input tray.



NOTE: Continuous feeding allows you to place additional batches of documents in the feeder for “infinite” feeding (with operator assistance). When only a few documents from one batch remain in the feeder, place the next batch **face down** on top of those documents.

## Selecting your scanning application

**Smart Touch** — Kodak provides Smart Touch functionality which allows you to quickly and easily perform common scanning tasks; such as:

- scan and share incoming client correspondence with a co-worker in a branch office
- create a searchable PDF of a printed report
- scan, fax/print an invoice
- scan a photo to add to a presentation

Nine predefined task shortcuts are available for you to use. You can modify and rename any of the shortcuts to create your own custom tasks. You can also preview and easily edit images (zoom, pan, rotate, crop, and much more) before they are sent to their destination.

For more information about Smart Touch, see the *User's Guide for Smart Touch* on the Installation CD.

**NOTE:** Smart Touch was installed when you installed the *Kodak Driver Software*. The rest of the above scanning applications are provided on separate CDs that were included with your scanner. Refer to the application's User's Guide for instructions on how to install and use it.

# 4 Document Printing

---

## Contents

Printer specifications.....	4-2
Installing/Replacing the ink cartridge .....	4-3
Enhanced printer .....	4-4
Document printer .....	4-6
Running a print test.....	4-7
Changing print positions .....	4-10
Replacing the ink blotter strips.....	4-11
Supplies .....	4-12
Problem solving .....	4-13

### NOTES:

- The *Kodak i1405* and *i1410* Scanners do not have document printing functionality.
- Refer to the Image Processing Guide on the CD or your scanning application documentation for more information about enabling printing and setting up print strings.

The Document Printer/Enhanced Printer operates at full scanner speed. The printer can add a date, time, document sequential counter, and custom messages.

The print string can be configured to include static information (i.e., information that stays the same for each document, such as batch name or operator) and dynamic information (i.e., information that may change for each page scanned, such as the document sequential counter). The capture software application controls static fields; any information that the software allows you to enter can be sent to the printer.

All printer controls and functions are accessible through the ISIS Driver or TWAIN Datasource. Printing must be enabled or disabled for each scan session, which is usually done by using a *Setting Shortcut* (TWAIN Datasource).

### NOTES:

- Clean the scanner's paper path components daily when using the printer.
- You cannot print on documents that are smaller than 10 cm (4 in.).
- The ink cartridge must be installed before turning on the scanner, or it could result in errors when printing is attempted.

## Printer specifications

Characteristic	Description
Maximum lines	1
Maximum characters	40
Print locations (vertical)	Set by capture software application
Print orientation	0 and 90 degrees
Font size	Bold or Normal NOTE: Not all languages can support a Bold font based on the complexity of the characters, such as half-width Katakana.
Print side	Rear (post-scan)
Minimum printing distance from document lead edge	0.89 cm (0.35 in.)
Static fields available	User-specified messages via capture software application
Dynamic fields available	Up to a nine-digit sequential document number, date, four-digit time
Languages supported	Any phonetic language. For example: Dutch, English, French, German, Italian, Portuguese, Spanish, Japanese (half-width Katakana)
<b>Document Printer</b>	
Print locations (horizontal)	14 front manually set
Ink cartridge	Black: CAT No. 135 5155 10 cartridges per package
Characters per ink cartridge	up to 350,000 to 450,000 (based on font size used)
<b>Enhanced Printer</b>	
Print locations (horizontal)	9 front manually set
Ink cartridge	Black: HP-C6602A Red: HP-C6602R
Characters per ink cartridge	up to 1,500,000 to 2,000,000 (based on font size used)

## Installing/Replacing the ink cartridge

Before using the printer, you must install the ink cartridge.

After initial installation, replace the ink cartridge when:

- printed characters appear light or uneven
- missing characters are evident
- a print test reveals inconsistent character quality
- cleaning has not improved the overall print quality

*IMPORTANT: Dispose the empty ink cartridge in accordance with all federal, state and local laws.*

1. Locate the printer access door on the back of the scanner.
2. Slide your fingers under the printer access door handle and pull the door toward you.

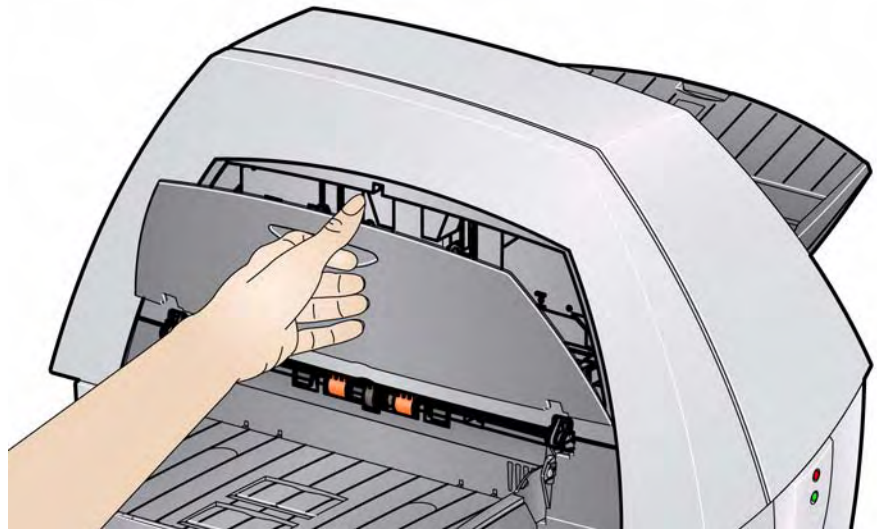

3. Lift the printer access door off the scanner.
4. If you have the Enhanced Printer, continue with the next step. If you have a Document Printer, go to the section entitled, "Document printer" and continue.

## Enhanced printer

5. If you are installing the ink cartridge for the first time, push the connector on the printer cable firmly into the printer carrier.

**NOTE:** If you are replacing an ink cartridge, the printer cable will already be installed and you just need to remove the printer carrier from its position and remove the empty ink cartridge.

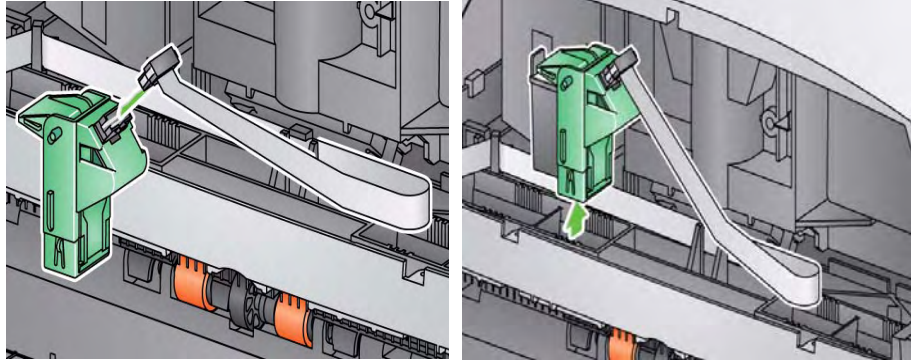

**Push the connector on the printer cable firmly into the printer carrier. Remove the printer carrier from its position.**

6. Open the ink cartridge and remove the tab from the new ink cartridge.
7. Lift the green tab on the printer carrier and slide the new ink cartridge in the printer carrier and close the tab.

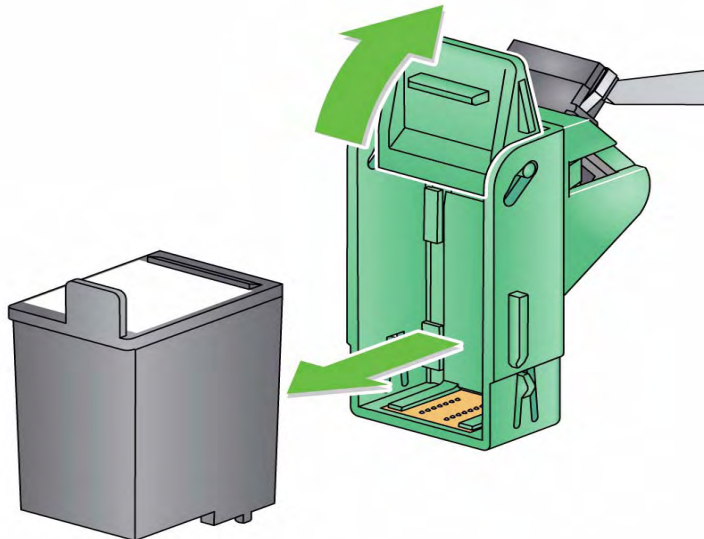

**NOTE:** If the ribbon cable should become disconnected, snap it back into position.

8. Slide the printer carrier into the desired print position. See the section entitled, "Changing print positions" later in the chapter for more information.

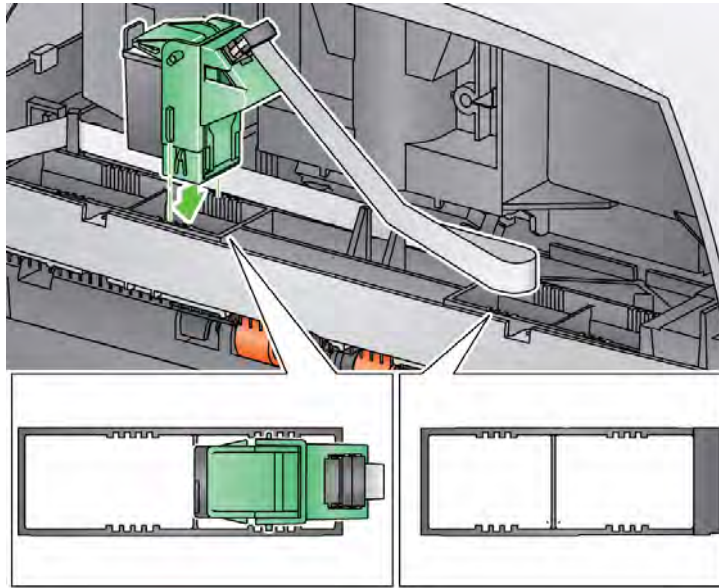

9. Reinstall and close the printer access door.
10. Run a print test. See the section entitled, "Running a print test" for procedures.



## Document printer

1. If you are installing the ink cartridge for the first time, push the connector on the printer cable firmly into the printer carrier.

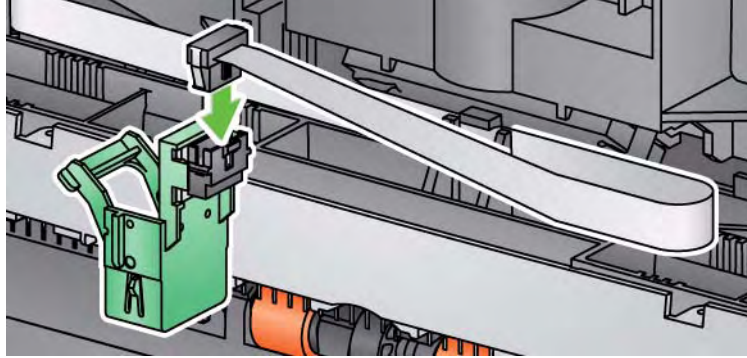

NOTE: If you are replacing an ink cartridge, the printer cable will already be installed and you just need to remove the printer carrier from its position and remove the empty ink cartridge.

2. Open a new ink cartridge, slide it into the printer carrier and lower the locking bar around the ink cartridge.

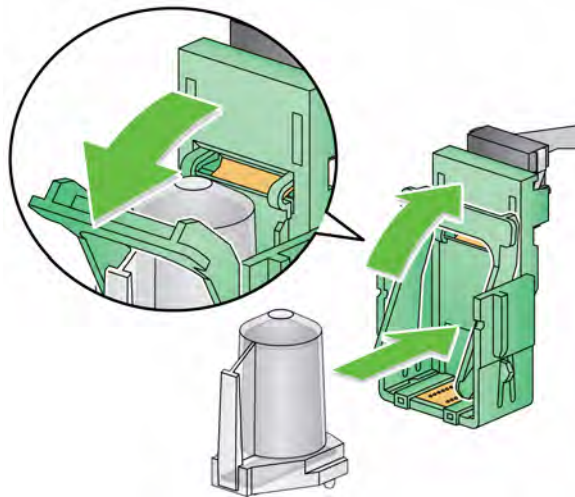

NOTE: If the ribbon cable should become disconnected, snap it back into position.



- Slide the printer carrier into the desired print position. See the section entitled, “Changing print positions” later in this chapter for more information.

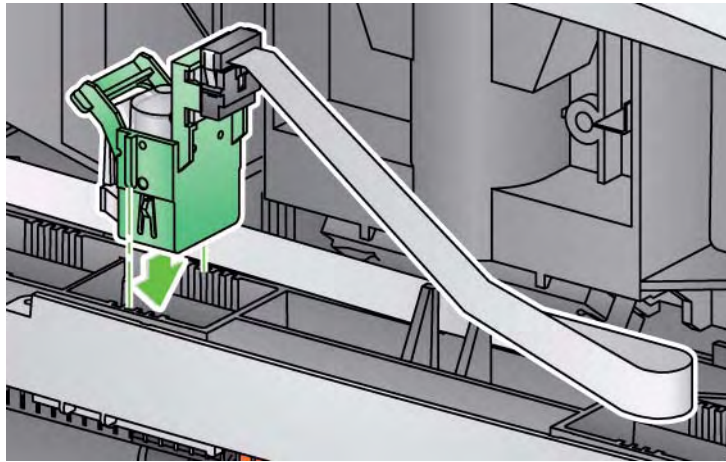

- Reinstall and close the printer access door.
- Run a print test. See the next section for procedures.

## Running a print test

You can only run a print test by using the *Kodak* Scan Validation Tool.

- Place a blank sheet of paper in the input tray.
- Ensure that the ink cartridge is properly installed.
- Select **Start>Programs>Kodak>Document Imaging>Scan Validation Tool**.

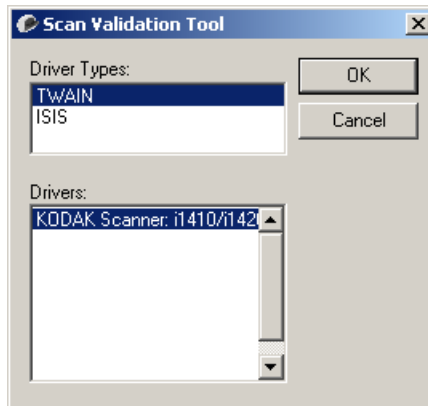

- Select **TWAIN** for the Driver Type and the **KODAK Scanner: i1410/i1420/i1440**. The Scan Validation Tool dialog box will be displayed.



5. Click the **Setup**  icon. The Scan Validation Tool main window will be displayed.

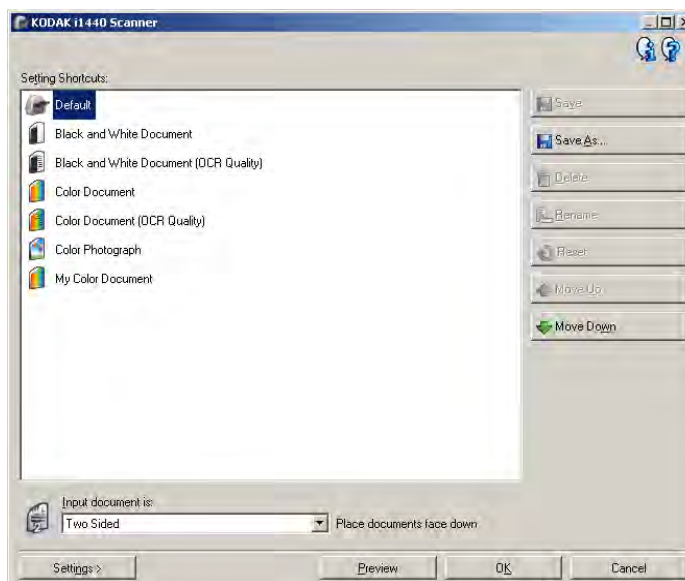

6. Select the **Default** Setting Shortcut and click **Settings**.

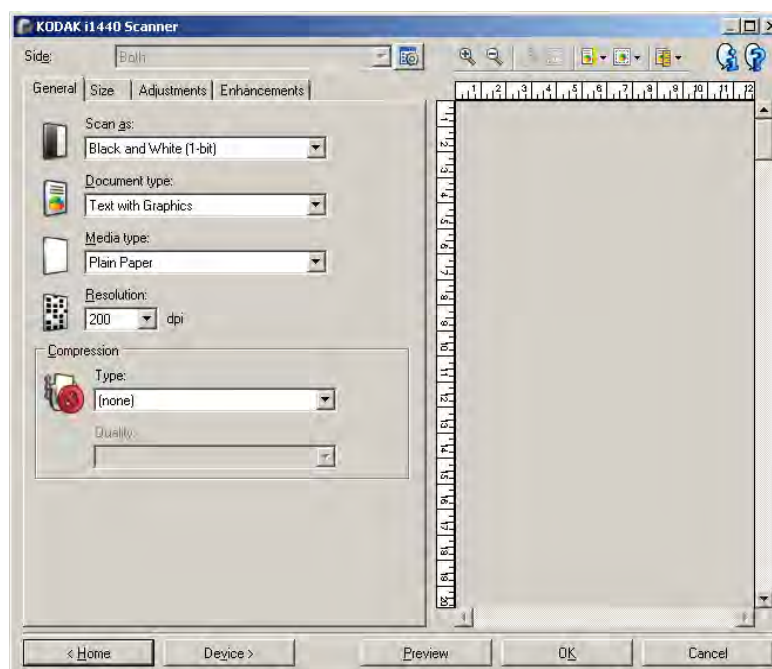

7. On the General tab, click the **Device** button.

8. On the Device - General tab, click the **Diagnostics** button. The General-Diagnostics window will be displayed.

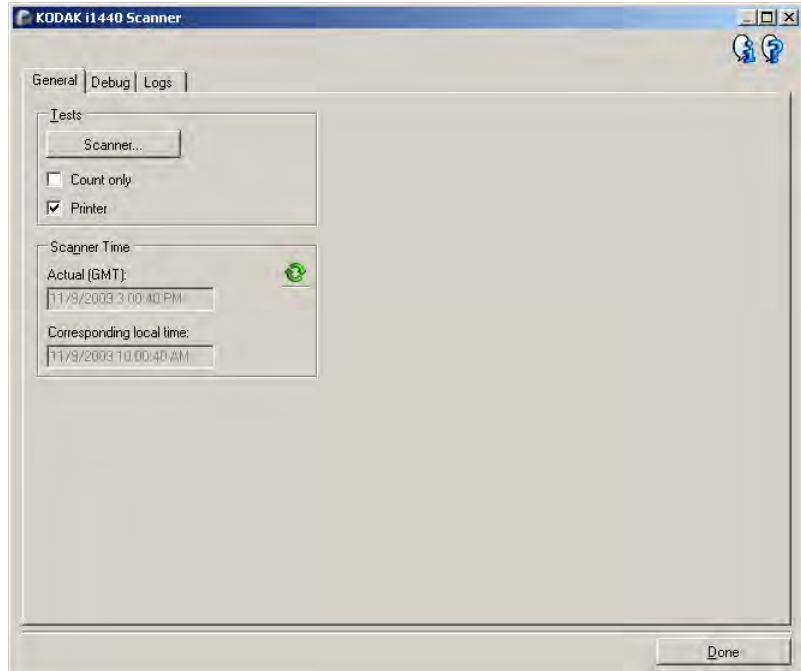

9. Check the **Printer** check box and click **Done**.
10. Scan the blank sheet of paper that is in the input tray.
11. Check the quality of the test pattern. If the test pattern is inconsistent, you may need to clean the print head or change the ink cartridge.



**Acceptable**

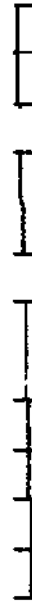

**Unacceptable: pattern is inconsistent**

## Changing print positions

The horizontal print position can be changed manually.

NOTE: Changing the print position is the same procedure whether you are using the Document Printer or the Enhanced Printer. The illustrations may be slightly different depending on the printer you are using.

1. Locate the printer access door on the back of the scanner.
2. Slide your fingers under the printer access door handle and pull the door toward you.
3. Lift the printer access door off the scanner.

### NOTES:

- Even though there are 14 horizontal print positions, if you are using the Enhanced Printer, you can only print in 9 of the positions.
  - If you are using the Document Printer, all 14 print positions are available for printing.
  - These positions are visible by a small detent on the printer rail.
  - Printing automatically stops approximately 1.27 cm ( ½-inch) from the trailing edge of the document even if the information has not been completely printed.
4. Lift up on the printer carrier and remove it from position.

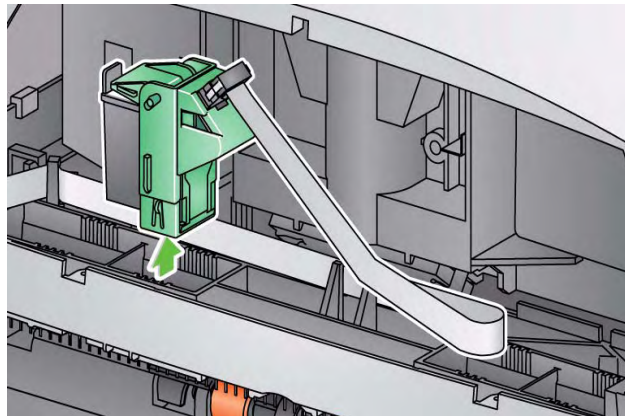

5. Align the slot on the printer carrier with the desired position and slide the printer carrier in place.
6. Reinstall the printer access door.

## Replacing the ink blotter strips

The two ink blotter strips in the scanner transport area collect ink overflow. To order additional ink blotter strips, see the section entitled, "Supplies" later in this chapter.

1. Push up on the scanner cover release latch and open the scanner cover.

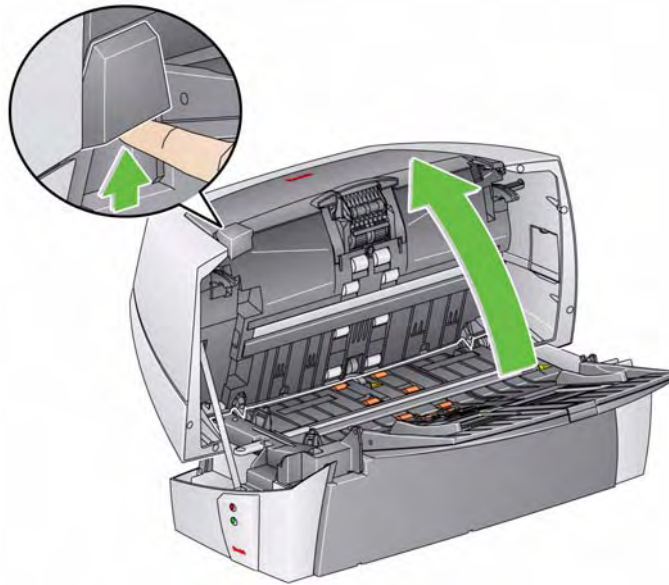

2. Locate the two blotter strip channels. These channels are where the blotter strips will be installed or replaced.

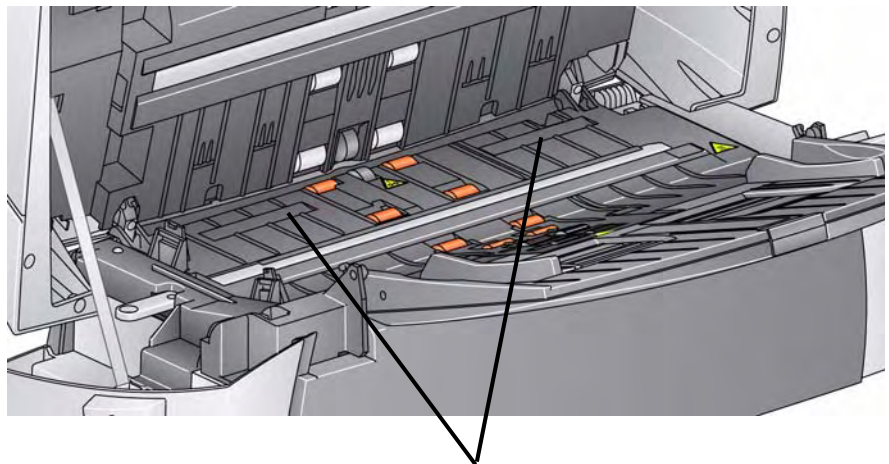

Blotter strip channels

3. If you are replacing a blotter strip, proceed with Step 5, if not, go to Step 6.



4. Grasp the blotter strip, carefully pull it off of the channel and discard the soiled strip.

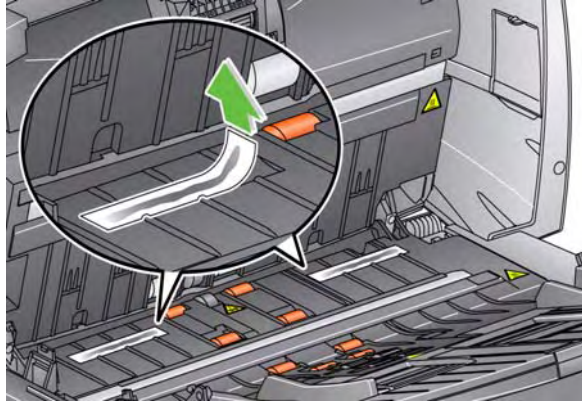

5. Remove the backing from a new blotter strip.
6. Align the blotter strip in one of the channels.

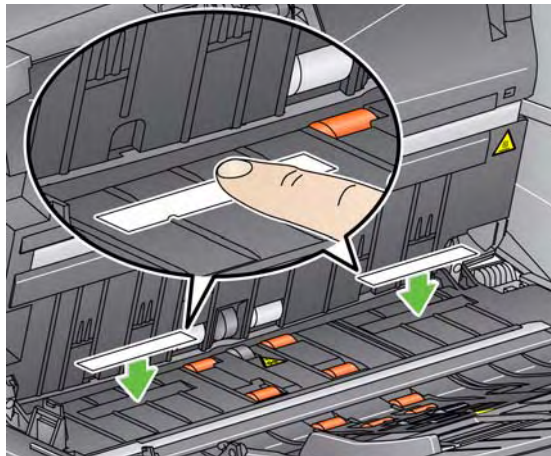

NOTE: Improperly aligned blotter strips may cause paper jams.

7. Press the adhesive side of the blotter strip down firmly into the channel.
8. Repeat Steps 4-7 for the other strip.
9. Lower the scanner cover and press it firmly until it snaps into place.

## Supplies

The following supplies are available:

Description	CAT No.
<b>Document Printer:</b> Printer Ink Cartridges / Black (Qty 10)	135 5155
<b>Document Printer:</b> Kodak Print Ink Blotters (Qty 60)	840 5425
<b>Document Printer:</b> Kodak Printer Ink Cartridge Carrier	826 7486
<b>Enhanced Printer:</b> Black Ink Cartridge (HP C6602A)	818 3386
<b>Enhanced Printer:</b> Red Ink Cartridge (HP C6602R)	159 6832
<b>Enhanced Printer:</b> Ink Cartridge Carrier	113 3842

## Problem solving

Use the list below as a guide to check possible solutions to problems you may encounter when using the printer.

Problem	Possible Solution
<b>Print quality is poor or inconsistent</b>	<ul style="list-style-type: none"><li>• Be sure the ink cartridge is not empty.</li><li>• Be sure the ink cartridge is properly installed.</li><li>• Be sure the ink cartridge is in the correct position for printing.</li><li>• Verify that the printer has been enabled in the capture software application and that the expected print string has been specified.</li><li>• Verify that all printer connectors are securely fastened and that the printer cable is securely attached.</li><li>• Run a print test to verify that all jets are functioning properly.</li><li>• Clean the print head (see "Printing problems when starting up due to dry print head" below).</li></ul>
<b>Printing problems when starting up due to dry print head</b>	Remove the ink cartridge from the scanner and using a damp cloth or swab, dab (do not wipe) the ink jets on the ink cartridge, replace the ink cartridge and try again.
<b>Not printing</b>	<ul style="list-style-type: none"><li>• Check to be sure that the ink cartridge is securely in the desired print position in the scanner.</li><li>• Be sure the tape is removed from the print head.</li></ul>

# 5 Maintenance

---

## Contents

Opening the scanner cover.....	5-1
Cleaning procedures.....	5-2
Cleaning the rollers and transport .....	5-3
Cleaning the separator module .....	5-4
Cleaning the feed module .....	5-5
Cleaning the imaging guides.....	5-7
Running a transport cleaning sheet.....	5-7
Replacement procedures .....	5-8
Replacing the feed module and feed module tires .....	5-9
Replacing the separator module and separator module tires.....	5-11
Replacing the pre-separation pad .....	5-13
Replacing the imaging guides.....	5-14
Supplies and consumables .....	5-17

## Opening the scanner cover

1. Power down the scanner.
2. Remove any documents from the feeder area.
3. Push up on the scanner cover release latch and open the scanner cover.

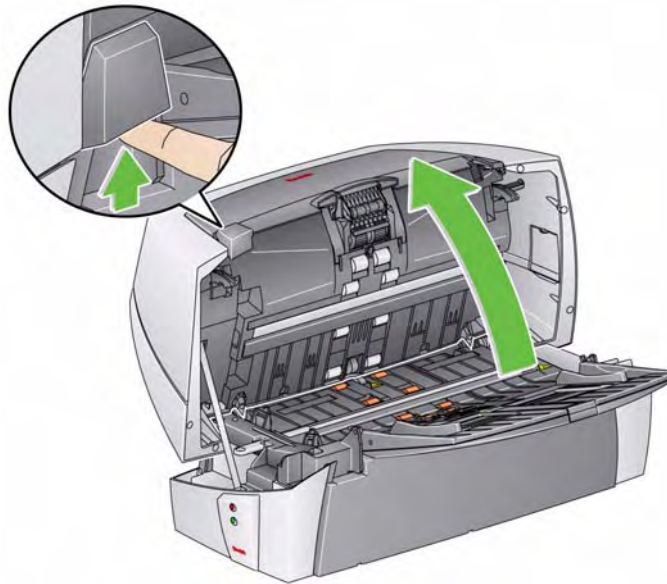

4. When finished cleaning the scanner or replacing a part, close the scanner cover with both hands; push it down firmly until it latches into place.



## Cleaning procedures

Cleaning your scanner and preventative maintenance on a regular basis is required to ensure the best possible image quality.

Some document types generate more paper dust and debris and may require more frequent cleaning than recommended.

Before cleaning your scanner or replacing parts, review the following information:

- Some debris from the rubber tires on the feed and separator modules is normal. Tire debris does not always mean that the tires are worn or damaged. After cleaning, inspect the tires for wear and replace the separator module or feed module if necessary.
- When cleaning rollers/tires, allow the rollers/tires to dry completely before scanning.
- Use only the recommended cleaning supplies. Using unapproved cleaning fluids or solvents may damage the rubber tires.
- Do not use cleaners in confined areas, use with adequate ventilation.
- Do not use cleaners on hot surfaces. Allow surfaces to cool to ambient temperature before use.
- Do not use canned/compressed air.
- In addition to the recommended cleaning supplies, you may use a vacuum cleaner to remove debris from the scanner.
- Staticide Wipes contain isopropanol which can cause eye irritation and dry skin. Wash your hands with soap and water after performing maintenance procedures. Refer to the Material Data Safety Sheet (MSDS) for more information. The MSDS is available on the Kodak web site at [www.kodak.com/go/MSDS](http://www.kodak.com/go/MSDS).
- The roller cleaning pad contains sodium lauryl ether sulfate and sodium silicate which can cause eye irritation. Refer to the MSDS for more information.

## Cleaning the rollers and transport

1. Manually rotate and wipe the rollers with a roller cleaning pad.

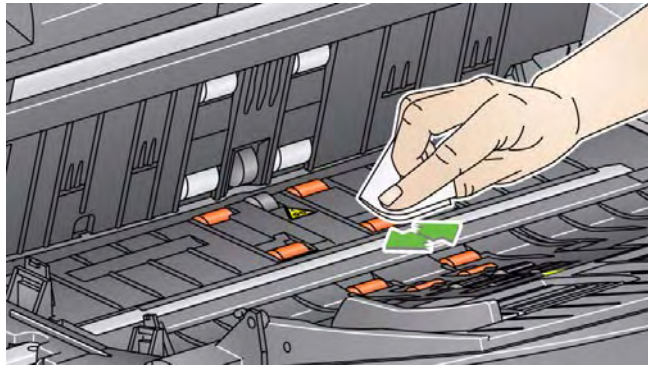

2. Clean any dust or debris in the slots around the drive rollers.
3. Wipe the upper and lower transport areas with a roller cleaning pad.
4. Dry the transport area with a dry Staticide Wipe.
5. Push against the raised edge on the left side of the rear roller cover and pull the cover up and out to remove it.

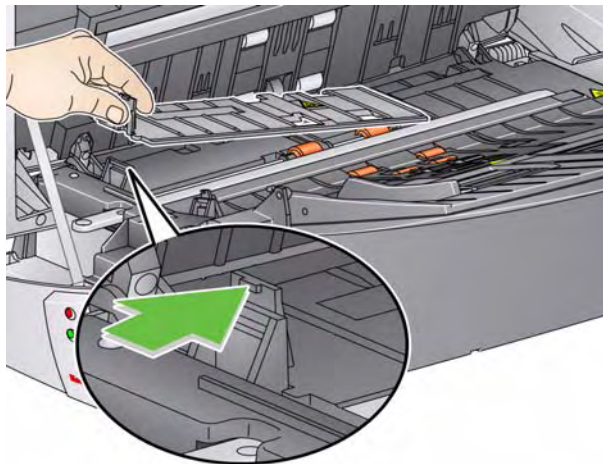

6. Remove any dust or debris under the rear drive roller cover.
7. Reinstall the rear drive roller cover.

## Cleaning the separator module

1. Push up on the scanner cover release latch and open the scanner cover.
2. Lift the separator module up and out of position.

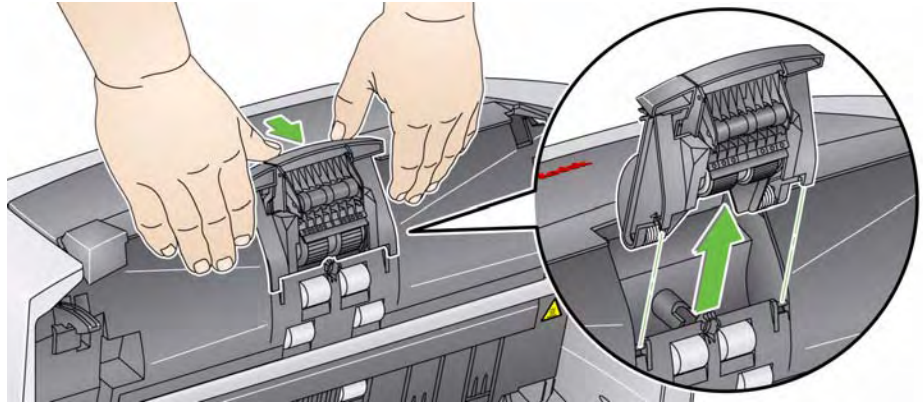

3. Manually rotate and wipe the separator module tires with a roller cleaning pad.

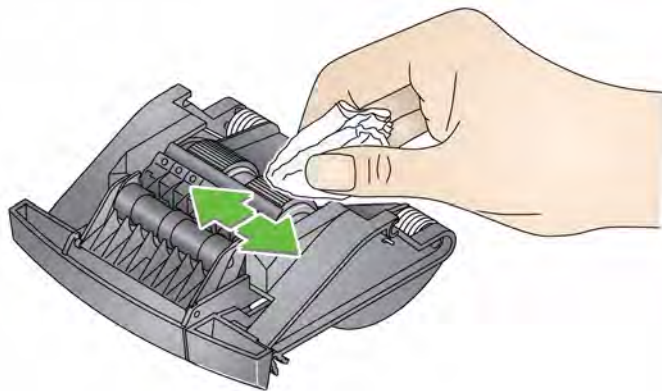

4. Inspect the tires. If the separator module tires show signs of wear or damage, replace the tires or the separator module. See the section entitled, "Replacing the separator module and separator module tires" later in this chapter.
5. Insert the separator module and align the shaft ends.

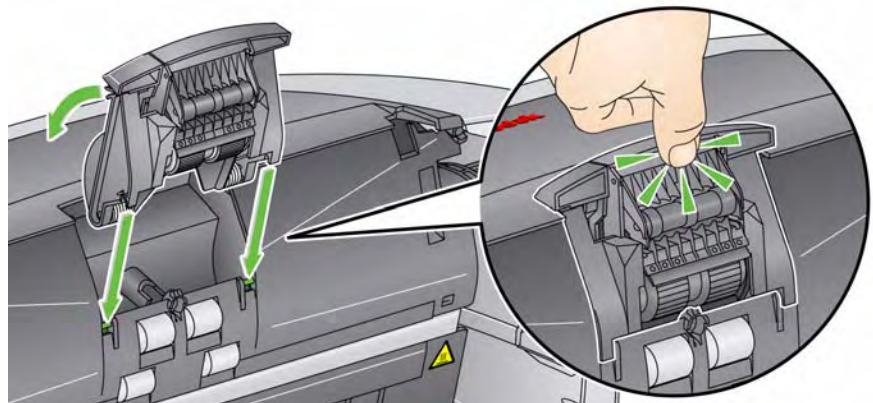

6. Press until the separator module clicks into place.

## Cleaning the feed module

1. Push against the raised edge on the left side of the front drive roller cover and pull the cover up and out to remove it.

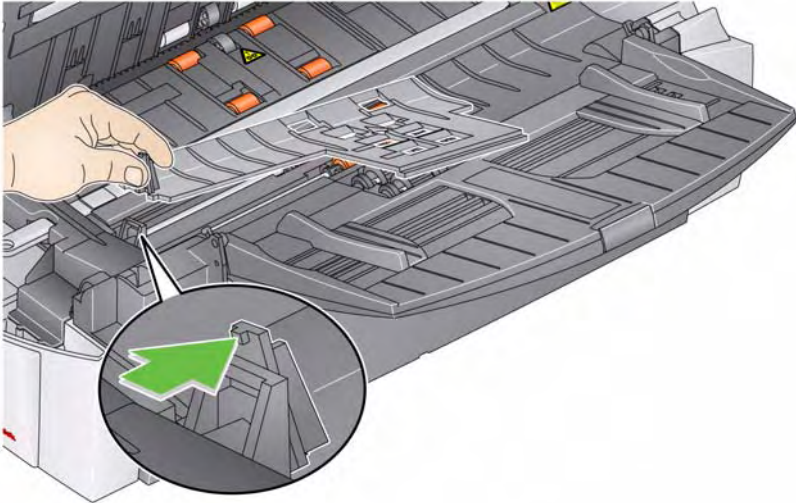

NOTE: You may need to lift the input tray slightly to remove the front roller cover.

2. Remove the feed module by pushing it to the right and lifting it out.

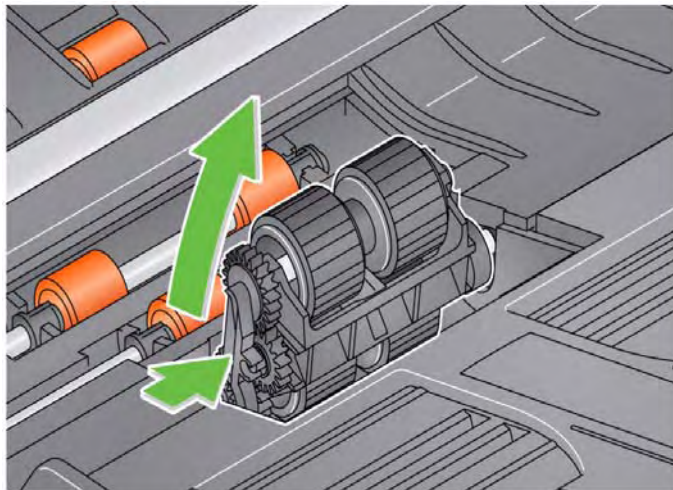



3. Manually rotate and wipe the feed module tires with a roller cleaning pad.



4. Inspect the feed module. If the feed module tires show signs of wear or damage, replace the tires or the feed module. See the section entitled, "Replacing the feed module and feed module tires" later in this chapter.
5. Remove any dust or debris from the tray area under the feed module and the front roller cover.
6. Insert the feed module by aligning the pins and pushing it toward the right to fit it into position.
7. Reinstall the front drive roller cover.
8. Wipe the upper and lower transport areas with a roller cleaning pad.

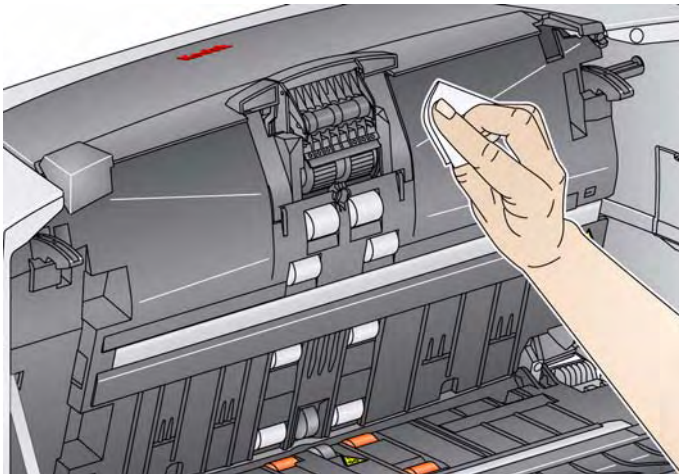

9. Dry the transport area with a dry Staticide Wipe.

## Cleaning the imaging guides

Clean the exposed (top side) surfaces of the imaging guides. You do not need to remove the imaging guides for cleaning unless there is dust or dirt on the underside of the imaging guide. If you need to remove the imaging guides, follow the instructions for “Replacing the imaging guides” later in this chapter.

1. Wipe the upper and lower imaging guides with a Staticide Wipe.

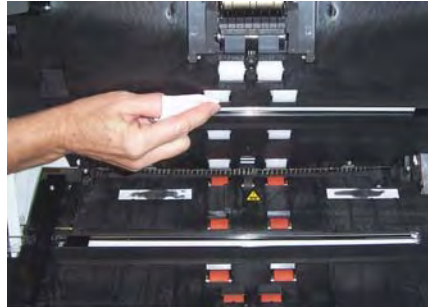

2. Dry the imaging guides with an almost dry Staticide Wipe.
3. Close the scanner cover with both hands; push it down firmly until it latches into place.

## Running a transport cleaning sheet

1. Remove the wrapping from the Transport Cleaning Sheet.
2. Adjust the side guides to fit the cleaning sheet.
3. Feed the cleaning sheet (adhesive side up) through the scanner in portrait orientation until all residue is removed from the drive rollers.
4. Adjust the side guides to fit, then feed the cleaning sheet (adhesive side up) through the scanner in landscape orientation until all residue is removed from the drive rollers.
5. Using the same cleaning sheet, repeat Steps 3 and 4, but feed the cleaning sheet through the scanner with the adhesive side down until all residue is removed from the drive rollers.

**NOTE:** When a cleaning sheet gets very dirty, discard it and use a new one.

## Replacement procedures

This section provides procedures for replacing the following parts. Use the list below as a guideline for frequency or replacement. Usage figures are not guaranteed. Customer-operating environments, document type, the condition of documents being scanned, and not following the recommended cleaning and replacement procedures, can cause the life of the consumables to vary.

- Separator Module: 200,000 document pages
- Pre-separation Pad: 250,000 document pages
- Feed Module: 500,000 document pages
- Imaging Guides: replace when guides are scratched or damaged

### NOTES:

- *Kodak* Scanners use replaceable tires that can feed a wide range of document types, sizes and thicknesses. Tire life and performance will vary based on the customer's document set, the frequency of cleaning the transport and tires, and following the recommended schedule for changing tires. You should change the tires if you notice an increase in multiple feeds, stoppages, or a decrease in feeder performance that is not resolved by following the cleaning procedures.
- Certain paper types (such as carbonless paper or newsprint), failure to clean regularly, and/or use of non-recommended cleaning solvents can shorten roller life.

## Replacing the feed module and feed module tires

1. Push up on the scanner cover release latch and open the scanner cover.
2. Push against the raised edge on the left side of the front drive roller cover to the side and pull the cover up and out to remove it.

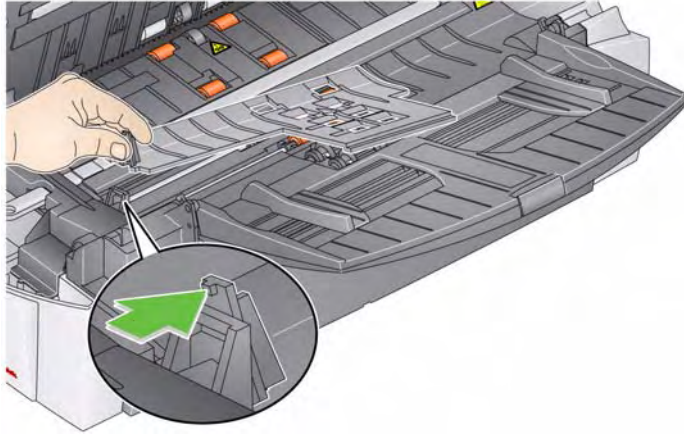

NOTE: You may need to lift the input tray slightly to remove the front roller cover.

3. Remove the feed module by pushing it to the right and lifting it out.

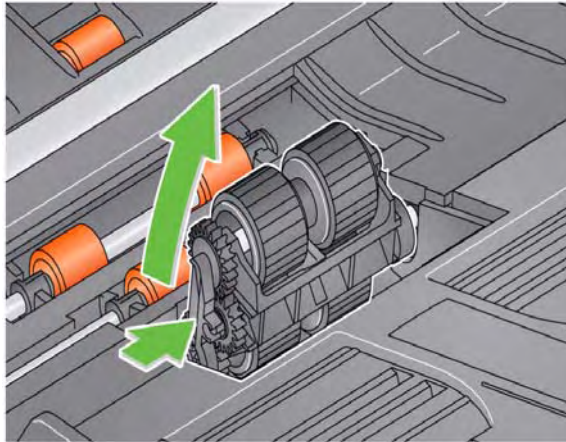

4. If you are just replacing the feed module, insert the new feed module by aligning the pins and snapping it into position.  
If you are replacing the feed module tires, continue with the next step.



- Lift and remove each core assembly and slide the tires off of the core.

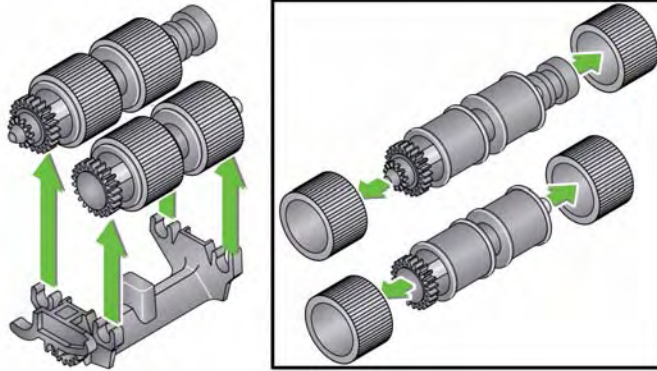

- Install each new tire by gently stretching it over the core.

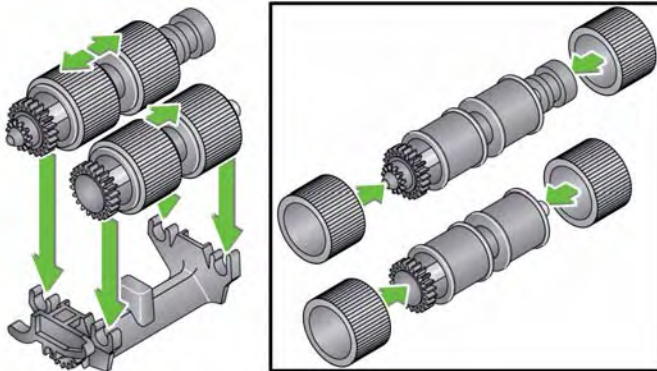

**IMPORTANT:**

- Do not overstretch the tire; it may tear.
  - Make sure that the tire is centered on the core and lies flat.
- Replace each core assembly in the feed module and snap it into place.
  - Reinstall the feed module.
  - Reinstall the front roller cover.
  - Close the scanner cover with both hands; push it down firmly until it latches into place.

## Replacing the separator module and separator module tires

1. Push up on the scanner cover release latch and open the scanner cover.

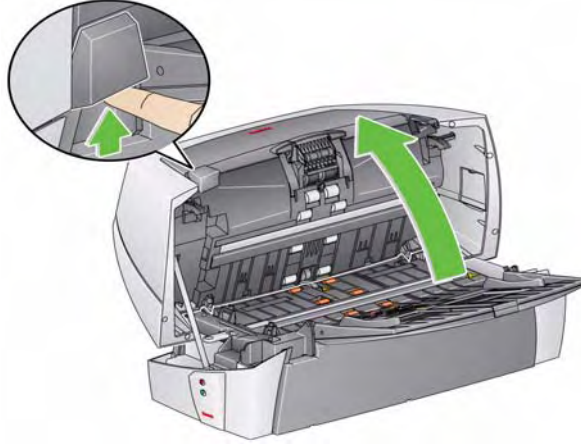

2. Lift the separator module up and out of position.

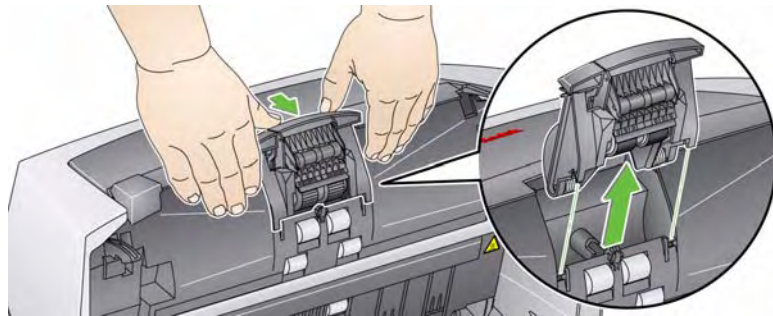

3. If you are just replacing the separator module, insert the new separator module by aligning the shaft ends and snapping it into position.

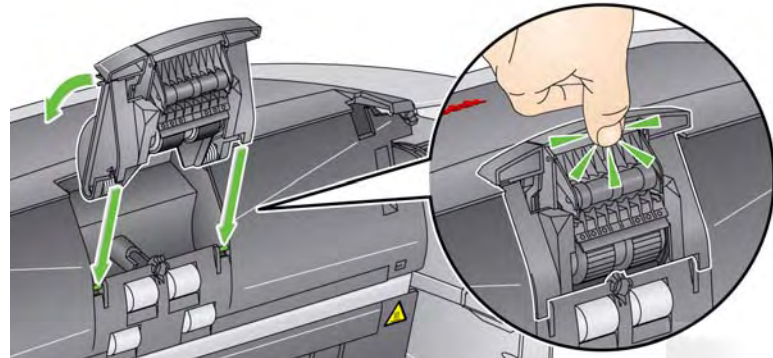

If you are replacing the separator module tires, continue with the next step.

4. Holding onto the separator module, rotate the release lever back so you can access the separator roller.

NOTE: Use caution as the separator module is spring-loaded and will snap back if you do not hold it in place.



5. Hold onto the separator module in this position with one hand, and with the other hand remove the separator roller.



6. Gently lower the separator module release lever back into place and set the separator module aside.
7. Remove each tire by sliding it off the core.
8. Install each new tire by gently stretching it over the core.

*IMPORTANT: Do not overstretch the tire; it may tear.*

*Make sure that the tire is centered on the core and lies flat.*

9. Reinstall the core (the direction does not matter).
10. Reinstall the separator module.
11. Close the scanner cover with both hands; push it down firmly until it latches into place.

## Replacing the pre-separation pad

1. Remove the separator module as previously directed.
2. Locate the pre-separation pad on the separator module.
3. Hold the separator module in both hands and find the two pre-separation pad side tabs which protrude slightly from the back of the separator module.



4. Push on the pre-separation pad side tabs on the back until the pre-separation pad protrudes slightly from the front of the separator module.
5. Grasp the pre-separation pad and pull it out of the separator module.



6. Discard the worn pre-separation pad.
7. Align the side tabs of a new pre-separation pad with the slots on the separator module.
8. Push the pre-separation pad firmly in the slots until the pre-separation pad flap rests lightly against the separator module tires.
9. Reinstall the separator module.
10. Close the scanner cover with both hands; push it down firmly until it latches into place.

## Replacing the imaging guides

### Replacing the upper imaging guide (for i1405, i1420 and i1440 Scanners only)

1. Open the scanner cover and locate the door on the right side of the scanner. Removing the side door will allow you to insert a screwdriver through the door opening to access the upper imaging guide.



2. Push down on the tab (shown above) to remove the side door. Set the side door aside.
3. Using a Phillips Head screwdriver, loosen the screw from the upper imaging guide bracket (slide the bracket over).





4. Pull gently on the end of the imaging guide and slowly remove it from the scanner.

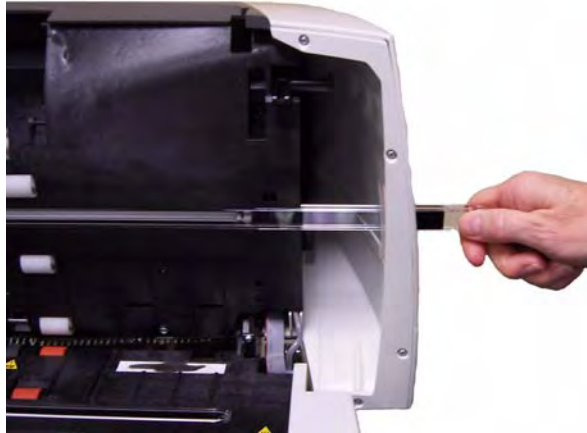

5. Discard the used imaging guide.
6. Remove any dust or debris from the guide track. Do not allow debris to fall into the scanner.
7. Wipe both sides of the new upper imaging guide with a fresh Staticide Wipe.
8. Dry both sides of the new upper imaging guide with an almost dry Staticide Wipe.
9. Align the new upper imaging guide in the guide track and slowly push it in.
10. Realign the upper imaging guide bracket and tighten the screw.



11. Reinstall the side door.

### Replacing the lower imaging guide (for all scanner models)

1. Locate the lower imaging guide.
2. Using a Phillips Head screwdriver, loosen the screw from the lower imaging guide.

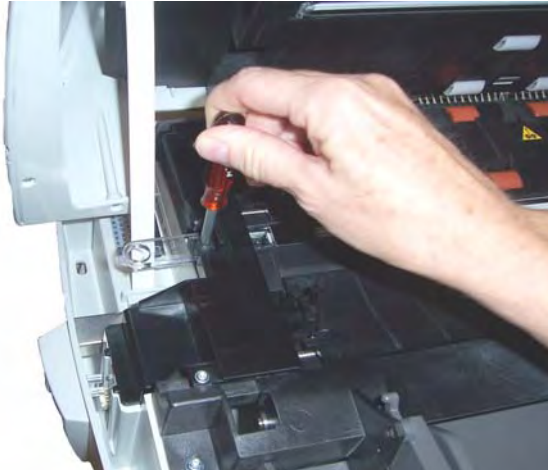

3. Slide the imaging guide out of the bracket and remove it from the scanner.

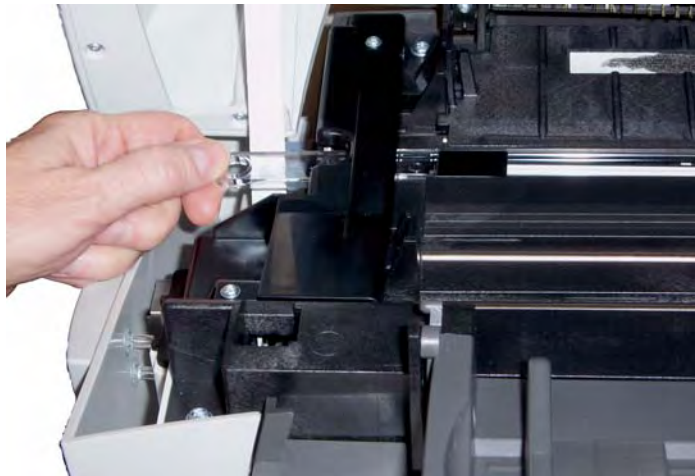

4. Discard the used imaging guide.
5. Remove any dust or debris from the guide track. Do not allow debris to fall into the scanner.
6. Wipe both sides of the new lower imaging guide with a fresh Staticide Wipe.
7. Dry both sides of the new lower imaging guide with an almost dry Staticide Wipe.
8. Align the new lower imaging guide in the guide track and slowly push it in.
9. Realign the lower imaging guide bracket and tighten the screw.
10. Close the scanner cover with both hands; push it down firmly until it latches into place.



## Supplies and consumables

Contact your scanner supplier to order supplies.

Supplies/Consumables	CAT No.
<i>Kodak Feeder Consumables Kit for i1400 Series Scanners</i>	124 1066
<i>Kodak Extra-Large Feeder Consumables Kit for i1400 Series Scanners</i>	821 5808
<i>Kodak Imaging Guide Set for i1400 Series Scanners (1 upper guide, 1 lower guide)</i>	197 8253
Document Printer: Printer Ink Cartridges (10)	135 5155
Document Printer: <i>Kodak</i> Printer Ink Blotters (60)	840 5425
Document Printer: <i>Kodak</i> Printer Ink Cartridge Carrier	826 7486
Enhanced Printer: Black Ink Cartridges (HP C6602A)	818 3386
Enhanced Printer: Red Ink Cartridge (HP C6602R)	159 6832
Enhanced Printer: Ink Cartridge Carrier	113 3842
Staticide Wipes for <i>Kodak</i> Scanners (144)	896 5519
<i>Kodak Digital Science</i> Transport Cleaning Sheets (50)	169 0783
<i>Kodak Digital Science</i> Roller Cleaning Pads (24)	853 5981
<i>Kodak</i> i1400 Series A3 Flatbed	179 6747
<i>Kodak</i> i1400 Series A4 Flatbed	167 7288

# 6 Troubleshooting

## Contents

Problem solving .....	6-1
Indicator lights and error codes.....	6-3
Service indicator lights .....	6-3
Contacting Service.....	6-4

## Problem solving

Occasionally you may encounter a situation with your scanner where it may not function properly. Use the chart below as a guide to check possible solutions to help you resolve the situation before calling Technical Support.

Use the chart below as a guide to check possible solutions to problems you may encounter when using the *Kodak i1400 Series Scanner*.

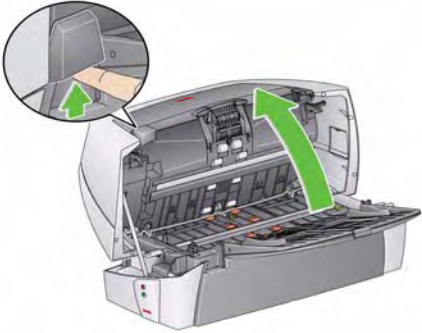
Problem	Possible Solution
Documents are jamming or multiple documents are feeding	<p>Make sure that:</p> <ul style="list-style-type: none"> <li>• the output tray and side guides are adjusted for the length and width of documents being scanned.</li> <li>• all documents meet specifications for size, weight, and type, etc. as outlined in Appendix A, <i>Specifications</i>.</li> <li>• all staples and paper clips have been removed from the documents.</li> <li>• all rollers and tires are clean and the separator module and feed module are properly installed. See the procedures in Chapter 5, <i>Maintenance</i>.</li> </ul> <p><b>To remove a document jam:</b></p> <ul style="list-style-type: none"> <li>• Remove any documents from the feeder area.</li> <li>• Push up on the scanner cover release latch and open the scanner cover</li> </ul>  <ul style="list-style-type: none"> <li>• Locate the jammed document and remove it.</li> <li>• Close the scanner cover with both hands; push it down firmly until it latches into place. Resume scanning.</li> </ul>

Problem	Possible Solution
The scanner will not scan/feed documents	<p>Make sure that:</p> <ul style="list-style-type: none"> <li>• the power cord is plugged in and the power is on.</li> <li>• the power switch is on and the green LED is lit.</li> <li>• the scanner cover is completely closed.</li> <li>• documents are making contact with the feed module.</li> <li>• the height of batched documents is less than 10.2 mm (0.4 in.) or approximately 150 sheets of 60 g/m<sup>2</sup> (16 lb.) paper.</li> <li>• documents meet specifications for size, weight, and type, etc.</li> <li>• for thicker documents, you lift the gap release lever during feeding.</li> <li>• you check the feed module and separator module for signs of wear, and replace these parts if necessary.</li> </ul> <p>You can also power the scanner down and power up again.</p>
Image quality is poor or has decreased	Make sure that the scanner and imaging guides are clean. Refer to Chapter 5, <i>Maintenance</i> .
“False” paper jams are occurring	<ul style="list-style-type: none"> <li>• Make sure that the paper transport area is clean.</li> </ul>
35.6 cm (14 in.) or longer documents are not feeding or are jamming	Make sure that the input and output tray extenders are pulled out to provide support for long documents.
The lamps shut off too soon	<p>The lamps in the i1400 Series Scanners will turn off after 15 minutes of no scanner activity. If the lamps are off, but the scanner has not yet gone into the Energy Star mode (default 15 minutes), there will be a delay of about 10 seconds for the lamps to warm up again.</p> <p>If you set the Energy Star timeout to a new value greater than 15 minutes, you must scan at least one document for that setting to be enabled. After this setting has been enabled, it will be enforced until a new setting is selected or the scanner is powered off and back on.</p>
Scanner is running slow	<ul style="list-style-type: none"> <li>• Your PC may not meet the minimum requirements for the scanner.</li> <li>• The scanner is rated and designed to operate with USB 2.0, but will function in a USB 1.1 port. If you are using a USB 1.1 connection, update your connection to USB 2.0.</li> </ul>
Cannot scan after Standby or Hibernate with Microsoft Windows Vista	Upgrade to Service Pack 1 or higher.
Documents are skewed during scanning	<p>Make sure that:</p> <ul style="list-style-type: none"> <li>• the side guides are adjusted to fit the documents being fed.</li> <li>• documents are being fed perpendicular to the feed module.</li> <li>• documents are being fed in the center of the feeder.</li> <li>• all staples and paper clips have been removed from the documents.</li> <li>• the feed module, separator module, and drive rollers are clean.</li> <li>• the scanner cover is firmly closed and latched.</li> </ul>
Scanner pauses excessively during scanning	<p>Make sure that:</p> <ul style="list-style-type: none"> <li>• the host computer meets minimum requirements for scanning.</li> <li>• there is enough free space on the hard disk drive.</li> <li>• all other applications are closed.</li> <li>• the USB connection is 2.0.</li> </ul> <p>You can also try changing the scanning options (compression, etc.) in your scanning application.</p>

Problem	Possible Solution
Documents are multifeeding	Make sure that: <ul style="list-style-type: none"> <li>• the leading edges of all batched documents are centered in the feeder so that each document will come in contact with the feed rollers.</li> <li>• the feed module and separator module are clean and not worn.</li> <li>• documents with an unusual texture or surface are fed manually.</li> </ul>
Roller marks or streaks appear on documents after scanning	Clean the feed module, separator module and rollers. Refer to Chapter 5, <i>Maintenance</i> .
Vertical lines appear on the image	• Clean the imaging guides. Refer to Chapter 5, <i>Maintenance</i> .
Received an unexpected error from the scanner	This error should rarely be seen, but if it does do the following: <ul style="list-style-type: none"> <li>• power off the scanner</li> <li>• restart your PC</li> <li>• power on the scanner</li> <li>• try again</li> </ul> If this problem persists, contact Service.

## Indicator lights and error codes

The indicator lights provide information on the current state of the scanner.

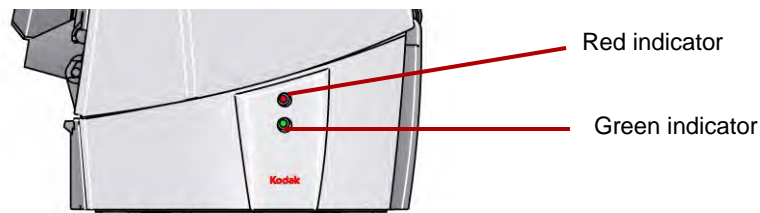

**Steady green:** indicates the scanner is ready to scan.

**Flashing green:** indicates the scanner is scanning or in power saver mode.

**Steady red:** indicates a scanner error, such as the scanner cover is open.

**Steady red and green** — scanner is powering up.

After you power up the scanner, the red and green indicator lights will illuminate. After approximately one minute, both lights go out. When the green indicator light comes back on, the scanner is ready to begin scanning. However, the host computer may require several seconds to detect the scanner.

## Service indicator lights

After you power up the scanner both LEDs are on.

**Red:** CPU not running code. The red indicator will go out after about 30 seconds. This indicator will always be off, unless you are downloading firmware, calibrating the scanner, the cover is opened or there is an error condition.

**Green:** the green indicator is on at all other times.

## Contacting Service

1. Visit [www.Kodak.com/go/disupport](http://www.Kodak.com/go/disupport) to obtain the most current phone number for your country.
2. When calling, please have the following information ready:
  - A description of your problem.
  - The scanner model and serial number.
  - Computer configuration.
  - Software application you are using.

# Appendix A Specifications

<b>Scanner Type/Speed</b>	<ul style="list-style-type: none"> <li>• i1405 Scanner: duplex color scanner with an automatic document feeder, 45 pages per minute (landscape)</li> <li>• i1410 Scanner: simplex color scanner with an automatic document feeder, 60 pages per minute (landscape)</li> <li>• i1420 Scanner: duplex color scanner with an automatic document feeder, 60 pages per minute (landscape)</li> <li>• i1440 Scanner: duplex color scanner with an automatic document feeder, 75 pages per minute (landscape)</li> </ul>
<b>Scanning Technology</b>	CCD type Grayscale output bit depth is: 256 levels (8 bit) Color capture bit depth is: 48 bits (16x3) Color output bit depth is: 24 bits (8x3)
<b>Output Resolutions</b>	75, 100, 150, 200, 240, 300, 400, 600 and 1200 dpi
<b>File Format Output</b>	TIFF, JPEG, RTF, PDF, searchable PDF (with bundled software)
<b>Scan Area</b>	Scans up to 30.5 x 86 cm / 12 x 34 inches. See the section entitled, "System requirements" for more information.
<b>Maximum Document Size</b>	297 mm x 863 mm (11.7 x 34 in.): for i1440 long document mode: 254 mm x 6.1 m (10 in. x 240 in. )
<b>Minimum Document Size</b>	64 mm x 89 mm (2.5 x 2.5 in.)
<b>Paper Thickness and Weight</b>	34 - 413 g/m <sup>2</sup> (9 - 110 lb.) paper
<b>ADF Capacity</b>	150 sheets of 60 g/m <sup>2</sup> (16 lb) paper
<b>Recommended Daily Volume</b>	<b>i1405:</b> 9,000 pages per day <b>i1410/i1420:</b> 12,000 pages per day <b>i1440:</b> 15,000 pages per day
<b>Illumination</b>	Fluorescent
<b>Electrical Requirements</b>	100 - 240 V (international), 50/60 Hz
<b>Scanner Dimensions</b>	<b>Height:</b> <b>i1410:</b> 23.6 cm (9.3 in.) <b>i1405/i1420/i1440:</b> 35.4 cm (14 in.) without trays; 36.4 cm (14.4 in.) trays folded up <b>Width:</b> <b>i1410:</b> 54.7 cm (21.5 in.) <b>i1405/i1420/i1440:</b> 54.7 cm (21.5 in.) <b>Depth:</b> 26.67 cm (10.5 in.) without trays; 30 cm (11.8 in.) trays folded up
<b>Scanner Weight</b>	<b>i1405:</b> 13.9 kg (30.5 lb.) <b>i1410:</b> 12.5 kg (27.5 lb.) <b>i1420:</b> 13.9 kg (30.5 lb.) <b>i1440:</b> 13.9 kg (30.5 lb.)
<b>Host Connection</b>	USB 2.0
<b>Operating Temperature</b>	10°C to 35°C (50° to 95°F)
<b>Humidity</b>	10 to 85% relative humidity
<b>Environmental Factors</b>	Energy Star qualified scanners

<b>Power Consumption - Scanner</b>	Sleep mode: <4 watts Running: <52 watts
<b>Power Consumption - with A3 Flatbed</b>	Sleep mode: <6 watts Running: <70 watts
<b>Power Consumption - with A4 Flatbed</b>	Sleep mode: ≤6 watts Running: <63 watts
<b>Acoustic Noise</b> (Sound Power level)	Operating: less than 58 dB Standby: less than 46 dB

NOTE: The *Kodak A3/A4 Flatbed Accessory* is not available for the *Kodak i1405 Scanner*.

## System requirements

Following is the recommended system configuration to run *Kodak i1400 Series Scanners*.

- 3.5 GHz Intel Pentium IV processor with 3 GB of RAM
- USB port 2.0 (compatible with USB 1.1 but at slower speeds)
- 200 MB free hard disk space
- Supported operating systems:
  - Microsoft Windows Vista (32-bit); SP1 recommended
  - Microsoft Windows Vista SP1 x64 Edition
  - Microsoft Windows XP SP2/SP3 (32-bit)
  - Microsoft Windows XP x64 Edition SP2
  - Microsoft Windows 2003 Server R2 x64 Edition (TWAIN only)
  - Linux Ubuntu 6.0.6; 8.04 recommended
  - Linux SUSE 10.1; 11 recommended
  - Linux Fedora 8; 9 recommended

### Included Drivers:

- Windows operating systems: TWAIN, ISIS, WIA
- Linux distributions: TWAIN and SANE



# Appendix B Warranty - US and Canada only

---

Congratulations on the purchase of a *Kodak Scanner*. *Kodak Scanners* are designed to provide end users with the highest performance and reliability. All *Kodak Scanners* are covered by the following Limited Warranty.

## Limited Warranty for *Kodak Scanners*

Eastman Kodak Company provides the following Limited Warranty on *Kodak Scanners* (excluding spare parts and consumables) distributed by Kodak or through Kodak's authorized distribution channels:

Kodak warrants that a *Kodak Scanner*, from the time of sale through the Limited Warranty period applicable to the Product, will be free of defects in materials or workmanship and will conform to the performance specifications applicable for the particular *Kodak Scanner*.

All *Kodak Scanners* are subject to the Warranty Exclusions described below. A *Kodak Scanner* found to be defective or which does not conform to the product specifications will be repaired or replaced with new or refurbished product at Kodak's option.

Purchasers may determine the applicable Limited Warranty period for the *Kodak Scanners* purchased by calling (800) 822-1414, or by visiting [www.Kodak.com/go/disupport](http://www.Kodak.com/go/disupport) or by reviewing the Limited Warranty Summary Card enclosed with the *Kodak Scanner*.

Proof of purchase is required to demonstrate eligibility for warranty service.

## Warranty exclusions

Kodak's Limited Warranty does not apply to a *Kodak Scanner* that has been subjected to physical damage after purchase, caused, for example, by casualty, accident, acts of God or transportation, including (a) by a failure to properly package and ship the Scanner back to Kodak for warranty service in accordance with Kodak's then current Packaging and Shipping Guidelines, including failure to replace the shipping restraint prior to shipping, or by a failure to remove the shipping restraint prior to use; (b) resulting from the user's installation, system integration, programming, re-installation of user operating systems or applications software, systems engineering, relocation, reconstruction of data, or removal of the product or any component (including breakage of a connector, cover, glass, pins, or seal); (c) from service, modification or repair not performed by Kodak or a service provider authorized by Kodak or by tampering, use of counterfeit or other non-Kodak components, assemblies, accessories, or modules; (d) by misuse, unreasonable handling or maintenance, mistreatment, operator error, failure to provide proper supervision or maintenance, including use of cleaning products or other accessories not approved by Kodak or use in contravention of recommended procedures or specifications; (e) by environmental conditions (such as excessive heat or other unsuitable physical operating environment), corrosion, staining, electrical work external to the product or failure to provide electro-static discharge (ESD) protection; (f) by failure to install firmware updates or releases available for the product and (g) by such other supplemental exclusions published from time to time online at [www.Kodak.com/go/disupport](http://www.Kodak.com/go/disupport) or by calling (800) 822-1414.

Kodak provides no Limited Warranty for products purchased from countries other than the United States. Purchasers of products from foreign distribution channels must seek warranty coverage, if any, through the original source of purchase.

Kodak provides no Limited Warranty for products that are purchased as part of a third party manufacturer's product, computer system or other electronic device.

Any warranty for these products is provided by the OEM (Original Equipment Manufacturer) as part of that manufacturer's product or system.

The replacement product assumes the remainder of the Limited Warranty period applicable to the defective product or thirty (30) days, whichever is longer.

## Installation Warning and Disclaimer

KODAK WILL NOT BE RESPONSIBLE FOR ANY CONSEQUENTIAL OR INCIDENTAL DAMAGES RESULTING FROM THE SALE, INSTALLATION, USE, SERVICING OR IMPROPER FUNCTIONING OF THIS PRODUCT, REGARDLESS OF THE CAUSE. SUCH DAMAGES FOR WHICH KODAK WILL NOT BE RESPONSIBLE, INCLUDE, BUT ARE NOT LIMITED TO, LOSS OF REVENUE OR PROFIT, LOSS OF DATA, DOWNTIME COSTS, LOSS OF USE OF THE PRODUCT, COST OF ANY SUBSTITUTE PRODUCT, FACILITIES OR SERVICES OR CLAIMS OF CUSTOMERS FOR SUCH DAMAGES.

If there is any conflict between other sections of this appendix and the Limited Warranty, the terms of the Limited Warranty prevail.

## How to obtain Limited Warranty service

*Kodak* Scanners are supplied with information on unpacking, setup, installation and operation. Careful reading of the User's Guide will answer most of the technical questions the end user might have regarding proper installation, operation and maintenance of the product. However, should additional technical support be required, you may visit our website at: [www.Kodak.com/go/disupport](http://www.Kodak.com/go/disupport) or contact:

Kodak's Response Center: **(800) 822-1414**

The Response Center is available Monday – Friday (excluding Kodak holidays) 8 a.m. to 5 p.m. EST.

Before placing the call, the eligible purchaser should have the *Kodak* Scanner model number, part number, serial number and proof of purchase available. The eligible purchaser should also be prepared to provide a description of the problem.

Response Center personnel will assist the end user in resolving the problem over the phone. The end user may be asked to run some simple, self-diagnostic tests and report the resulting status and error code messages. This will assist the Response Center in determining if the problem is the *Kodak* Scanner or another component and if the problem can be resolved over the phone. If the Response Center determines a hardware problem exists that is covered either under the Limited Warranty or a purchased Maintenance Agreement, a Return Material Authorization Number (RMA) will be assigned as needed, a service request will be initiated and repair or replacement procedures will follow.

## Packaging and shipping guidelines

Purchaser must ship all warranty returns in a method that guarantees full protection of the product from shipping damage. Failure to do so will void the *Kodak* Scanner warranty. Kodak advises the purchaser to keep the original box and packing materials for storing or shipping. Kodak is not responsible for issues related to shipping damage. The purchaser must return only the *Kodak* Scanner. Prior to shipment, purchaser must remove and retain all "add-on" items, (i.e. adapters, cables, software, manuals, etc.). Kodak accepts no responsibility for these items and they will not be returned with the repaired or replacement *Kodak* Scanner. All products should be returned to Kodak in the original shipping container, or an authorized packaging box for the units being returned. Purchaser must install the shipping restraint before the *Kodak* Scanner is shipped. When the original packaging is not available, contact Kodak's Response Center at (800) 822-1414 for part numbers and replacement packaging ordering information.

## Return procedure

Eligible purchasers seeking services for *Kodak* Scanners covered under this Limited Warranty must obtain a Return Material Authorization number ("RMA") by calling (800) 822-1414 and within ten (10) business days from the date of issuance of the RMA must return the *Kodak* Scanner to the address designated in the RMA at the end user's own expense and risk, in compliance with Kodak's current Packaging and Shipping Guidelines.

Any defective products or parts replaced by Kodak become the property of Kodak.

## Customer responsibility

BY REQUESTING SERVICE, THE ELIGIBLE PURCHASER ACKNOWLEDGES THE TERMS OF THE LIMITED WARRANTY, INCLUDING THE DISCLAIMER AND LIMITATION OF LIABILITY PROVISIONS. PRIOR TO SEEKING SERVICE, THE END USER MUST BACK-UP ANY DATA OR FILES THAT MAY BECOME DAMAGED OR LOST. KODAK IS, WITHOUT LIMITATION, NOT RESPONSIBLE FOR LOST OR DAMAGED DATA OR FILES.

## Warranty Service descriptions

Eastman Kodak Company (*Kodak*) offers a range of service programs to support its Limited Warranty and to assist with the use and care of the *Kodak* Scanner ("Service Methods"). A *Kodak* Scanner represents an important investment. *Kodak* Scanners provide the productivity needed to stay competitive. The sudden loss of this productivity, even temporarily, could seriously affect the ability to meet commitments. Downtime can be very expensive, not just in the cost of the repair but also in time lost. To help alleviate these problems, Kodak may use one of the service methods listed below, depending upon product type, in providing service under its Limited Warranty.

Included with selected *Kodak* Scanners is a Limited Warranty Registration card and a Limited Warranty Summary card. The Limited Warranty Summary card is specific by model. The Limited Warranty Summary card contains important warranty information, including the model number and the Limited Warranty. Refer to the Limited Warranty Summary card to determine the available Service Methods applicable to the particular *Kodak* Scanner.

If the Limited Warranty Registration card or Limited Warranty Summary card cannot be located, additional information may be obtained about the product, including updated warranty and service program information and restrictions, online at [www.Kodak.com/go/disupport](http://www.Kodak.com/go/disupport) or by phone at (800) 822-1414.

To avoid service delays, Kodak urges end users to complete and return the enclosed Limited Warranty Registration Card at the first opportunity. If you cannot locate the Limited Warranty Registration card, you may register online at [www.Kodak.com/go/disupport](http://www.Kodak.com/go/disupport) or by phone at (800) 822-1414.

Kodak also provides a variety of service programs that may be purchased to assist with the use and care of the *Kodak* Scanner. Kodak is committed to providing its customers with quality, performance, reliability and service under the Limited Warranty.

## On-site service

For the selected *Kodak* Scanner, and after the Response Center verifies a hardware problem, a service call will be opened and logged. An *Kodak* Field Engineer will be dispatched to the product location to perform repair service if the product is located within the contiguous forty-eight (48) United States, in certain areas of Alaska and Hawaii, and if there are no security, safety or physical requirements that would restrict the Field Engineer's access to the scanner. For additional information on service areas, visit our website at: [www.Kodak.com/go/docimaging](http://www.Kodak.com/go/docimaging). On-Site Service will be provided between the hours of 8 a.m. and 5 p.m. local time, Monday through Friday (excluding *Kodak* holidays).

## AUR

AUR may be one of the easiest and most comprehensive service offerings in the industry. In the unlikely event of a product defect, for eligible purchasers of certain *Kodak* Scanners, *Kodak* will replace that product within two business days.

The AUR provides advance replacement on specific failed or broken *Kodak* Scanner. To be eligible to take advantage of the AUR, the eligible purchaser must obtain an RMA number, sign an Advance Replacement Agreement and provide a credit card deposit to secure the replacement product. The RMA number should be kept in the event that the status of the replacement product needs to be checked. The eligible purchaser will be asked for the address where the replacement product is to be shipped. The eligible purchaser will also be faxed packing and shipping instructions for the malfunctioning product. The eligible purchaser will then receive a replacement product within 2 business days after the service call initiation and *Kodak*'s receipt of the signed agreement. The malfunctioning product must be received by *Kodak* within ten (10) days of the end user's receipt of the replacement product or the end user's credit card will be charged the list price of the replacement product. Shipment of replacement Imaging Product will be made at *Kodak*'s expense and choice of freight carrier. Shipments not made under *Kodak*'s directions and choice of freight carrier may void the Limited Warranty.

Before the product is returned to *Kodak*, be sure to remove all options and accessories (which include power cord, documentation, etc.) that are not covered by the Limited Warranty. The box and packaging in which the replacement product was shipped must be used to return the malfunctioning product. If the malfunctioning product is not returned in the box and packaging in which the replacement product was shipped the Limited Warranty may be voided. The Return Material Authorization Number ("RMA") must be clearly marked on the outside of the box to ensure proper receipt and credit of the defective product.

## Depot service

If the *Kodak* Scanner is not eligible for Advance Exchange or On-Site Service, an eligible purchaser may utilize our Depot Repair Service. The eligible purchaser will be instructed to ship the product to the nearest authorized Depot Repair Center. Product must be shipped at the eligible purchaser's risk and expense to the repair center. Before the product is returned to the repair center, be sure to remove all options and accessories (which include power cord, documentation, etc.) not covered by the Limited Warranty. All products should be returned to *Kodak* in the original shipping container, or in a recommended packing box. The *Kodak* Scanner must have the shipping restraint installed before it is shipped. When the original packaging is not available, contact *Kodak*'s Response Center at (800) 822-1414, for ordering information. Eligible purchasers seeking services for *Kodak* Scanners must obtain a Return Material Authorization number ("RMA") by calling (800) 822-1414, and within ten (10) business days from the date of issuance of the RMA must return the *Kodak* Scanner to the address designated in the RMA at the end user's own expense and risk. The Return Material Authorization Number ("RMA") must be clearly marked on the outside of the box to ensure proper receipt and credit of the defective product.

Upon receipt of the product, the repair center will repair product within ten (10) business days. The repaired product will be shipped back two-day express mail at no expense to the eligible purchaser.

## Important restrictions

**Eligibility:** The Advance Exchange Program and the Depot Service are available to eligible purchasers in the fifty (50) United States, and On-Site Service is available in the contiguous forty-eight (48) states and in certain areas of Alaska and Hawaii for products purchased from authorized distributors of *Kodak*. The *Kodak* Scanner will be ineligible for any service under warranty if the product falls under any of *Kodak*'s then-current Warranty Exclusions, including a purchaser's failure to return defective products to *Kodak* in compliance with *Kodak*'s then current Packaging and Shipping Guidelines. Persons are only considered "eligible purchasers" or "end users" if they originally purchased the *Kodak* Scanner for their own personal or business use, and not for resale.

**Consumables:** Consumables are items that wear out under normal use and must be replaced by the end user as needed. Consumables, supplies, other expendable items and those items identified as being the user's responsibility in the User's Guide are not covered under the Limited Warranty.

If any of the above excluded parts or services are required, they may be available through an authorized service provider at their hourly rates and at terms then in effect.

Any defective products or parts replaced by *Kodak* become the property of *Kodak*.

## **Contacting Kodak**

For Information on *Kodak* Scanners:

Website: [www.Kodak.com/go/docimaging](http://www.Kodak.com/go/docimaging)

For U.S. Service, Repair and Technical Assistance by Telephone:

Telephone technical support is available Monday-Friday between the hours of 5 a.m. to 5 p.m. excluding Kodak holidays.

Phone: (800) 822-1414

For Technical Documentation and FAQ's available 24 hours a day:

Website: [www.Kodak.com/go/docimaging](http://www.Kodak.com/go/docimaging)

For Service Program Information

Website: [www.Kodak.com](http://www.Kodak.com)

Phone: (800) 822-1414

# Kodak

