

ThinkPad

**ThinkPad Edge 13" and E30
Hardware Maintenance Manual**

ThinkPad

**ThinkPad Edge 13" and E30
Hardware Maintenance Manual**

Note

Before using this information and the product it supports, be sure to read the general information under "Notices" on page 137.

First Edition (December 2009)

© Copyright Lenovo 2009.

LENOVO products, data, computer software, and services have been developed exclusively at private expense and are sold to governmental entities as commercial items as defined by 48 C.F.R. 2.101 with limited and restricted rights to use, reproduction and disclosure.

LIMITED AND RESTRICTED RIGHTS NOTICE: If products, data, computer software, or services are delivered pursuant a General Services Administration "GSA" contract, use, reproduction, or disclosure is subject to restrictions set forth in Contract No. GS-35F-05925.

© Lenovo 2009

Contents

About this manual	v	Intermittent problems	58
		Undetermined problems	58
Safety information	1	Status indicators	59
General safety	2	Special keys	61
Electrical safety	3	FRU replacement notices	63
Safety inspection guide	5	Screw notices	63
Handling devices that are sensitive to electrostatic discharge	6	Retaining serial numbers	64
Grounding requirements	6	Restoring the serial number of the system unit	64
Safety notices (multilingual translations)	7	Retaining the UUID	64
		Reading or writing the ECA information	65
Important service information	29	Removing and replacing a FRU	67
Strategy for replacing FRUs	30	1010 Battery pack	68
Strategy for replacing a hard disk drive	30	1020 Bottom slot cover	70
Important notice for replacing a system board	31	1030 DIMM	72
How to use error message	31	1040 Hard disk drive (HDD).	73
Strategy for replacing FRUs for CTO, CMV, and GAV	32	1050 PCI Express Mini Card for wireless LAN	75
Product definition	32	1060 PCI Express Mini Card for wireless WAN	77
FRU identification for CTO, CMV, and GAV products	32	1070 Keyboard	79
		1080 Top case assembly and microphone module	82
General checkout	35	1090 Backup battery	86
What to do first	36	1100 <i>Bluetooth</i> daughter card (BDC-2)	87
Checkout guide	37	1110 Speaker assembly	88
Diagnostics using PC-Doctor for DOS	37	1120 System board and fan assembly	90
Lenovo ThinkVantage Toolbox (Lenovo System Toolbox)	40	1130 I/O card assembly, audio cable, and I/O cable	98
PC-Doctor for Rescue and Recovery	40	1140 LCD unit	100
FRU tests	41	1150 Base cover assembly and DC-in cable	102
Power system checkout	43	2010 LCD bezel assembly	105
Checking the AC adapter	43	2020 Integrated camera	106
Checking operational charging	44	2030 LCD panel and LCD cable	107
Checking the battery pack	44	2070 Hinge kit	110
Checking the backup battery	45	2050 Wireless LAN antenna assembly, wireless WAN antenna assembly, and LCD rear cover assembly	112
Related service information	47	Locations	115
Restoring the factory contents by using Recovery Disc Set	47	Front view	115
Passwords	48	Bottom view	116
Power-on password	49	Parts list	117
Hard-disk password	49	Overall	118
Supervisor password	49	LCD FRUs	126
How to remove the power-on password	49	Keyboard	129
How to remove the hard-disk password	50	AC adapters	130
Power management	52	Miscellaneous parts	130
Screen blank mode	52	Power cords	131
Sleep mode	52	Recovery discs	132
Hibernation mode	52	Windows 7 Home Basic (32 bit) DVDs	132
Symptom-to-FRU index	53	Windows 7 Home Premium (32 bit) DVDs	132
Numeric error codes	53	Windows 7 Home Premium (64 bit) DVDs	133
Error messages	56	Windows 7 Professional (32 bit) DVDs	134
No-beep symptoms	56		
LCD-related symptoms	57		

Windows 7 Professional (64 bit) DVDs 135
Common service tools 136

Trademarks 138

Notices 137

About this manual

This manual contains service and reference information for the following ThinkPad® products.

ThinkPad Edge 13"

MT 0196, 0197, and 0492

ThinkPad Edge E30

MT 0196

Use this manual along with the advanced diagnostic tests to troubleshoot problems.

Important:

This manual is intended only for trained service technicians who are familiar with ThinkPad products. Use this manual along with the advanced diagnostic tests to troubleshoot problems effectively.

Before servicing a ThinkPad product, be sure to read all the information under "Safety information" on page 1.

Safety information

This chapter presents following safety information that you need to be familiar with before you service a ThinkPad Notebook.

- “General safety” on page 2
- “Electrical safety” on page 3
- “Safety inspection guide” on page 5
- “Handling devices that are sensitive to electrostatic discharge” on page 6
- “Grounding requirements” on page 6
- “Safety notices (multilingual translations)” on page 7

General safety

Follow these rules to ensure general safety:

- Observe good housekeeping in the area of the machines during and after maintenance.
- When lifting any heavy object:
 1. Make sure that you can stand safely without slipping.
 2. Distribute the weight of the object equally between your feet.
 3. Use a slow lifting force. Never move suddenly or twist when you attempt to lift.
 4. Lift by standing or by pushing up with your leg muscles; this action removes the strain from the muscles in your back. *Do not attempt to lift any object that weighs more than 16 kg (35 lb) or that you think is too heavy for you.*
- Do not perform any action that causes hazards to the customer, or that makes the equipment unsafe.
- Before you start the machine, make sure that other service technicians and the customer's personnel are not in a hazardous position.
- Place removed covers and other parts in a safe place, away from all personnel, while you are servicing the machine.
- Keep your toolcase away from walk areas so that other people will not trip over it.
- Do not wear loose clothing that can be trapped in the moving parts of a machine. Make sure that your sleeves are fastened or rolled up above your elbows. If your hair is long, fasten it.
- Insert the ends of your necktie or scarf inside clothing or fasten it with a nonconductive clip, about 8 centimeters (3 inches) from the end.
- Do not wear jewelry, chains, metal-frame eyeglasses, or metal fasteners for your clothing.

Attention: Metal objects are good electrical conductors.
- Wear safety glasses when you are hammering, drilling, soldering, cutting wire, attaching springs, using solvents, or working in any other conditions that might be hazardous to your eyes.
- After service, reinstall all safety shields, guards, labels, and ground wires. Replace any safety device that is worn or defective.
- Reinstall all covers correctly before returning the machine to the customer.
- Fan louvers on the machine help to prevent overheating of internal components. Do not obstruct fan louvers or cover them with labels or stickers.

Electrical safety

Observe the following rules when working on electrical equipment.

Important:

Use only approved tools and test equipment. Some hand tools have handles covered with a soft material that does not insulate you when working with live electrical currents.

Many customers have, near their equipment, rubber floor mats that contain small conductive fibers to decrease electrostatic discharges. Do not use this type of mat to protect yourself from electrical shock.

- Find the room emergency power-off (EPO) switch, disconnecting switch, or electrical outlet. If an electrical accident occurs, you can then operate the switch or unplug the power cord quickly.
 - Do not work alone under hazardous conditions or near equipment that has hazardous voltages.
 - Disconnect all power before:
 - Performing a mechanical inspection
 - Working near power supplies
 - Removing or installing main units
 - Before you start to work on the machine, unplug the power cord. If you cannot unplug it, ask the customer to power-off the wall box that supplies power to the machine, and to lock the wall box in the off position.
 - If you need to work on a machine that has *exposed* electrical circuits, observe the following precautions:
 - Ensure that another person, familiar with the power-off controls, is near you.

Attention: Another person must be there to switch off the power, if necessary.
 - Use only one hand when working with powered-on electrical equipment; keep the other hand in your pocket or behind your back.

Attention: An electrical shock can occur only when there is a complete circuit. By observing the above rule, you may prevent a current from passing through your body.
 - When using testers, set the controls correctly and use the approved probe leads and accessories for that tester.
 - Stand on suitable rubber mats (obtained locally, if necessary) to insulate you from grounds such as metal floor strips and machine frames.
- Observe the special safety precautions when you work with very high voltages; Instructions for these precautions are in the safety sections of maintenance information. Use extreme care when measuring high voltages.
- Regularly inspect and maintain your electrical hand tools for safe operational condition.
 - Do not use worn or broken tools and testers.
 - *Never assume* that power has been disconnected from a circuit. First, *check* that it has been powered off.
 - Always look carefully for possible hazards in your work area. Examples of these hazards are moist floors, nongrounded power extension cables, power surges, and missing safety grounds.

- Do not touch live electrical circuits with the reflective surface of a plastic dental mirror. The surface is conductive; such touching can cause personal injury and machine damage.
- Do not service the following parts *with the power on* when they are removed from their normal operating places in a machine:
 - Power supply units
 - Pumps
 - Blowers and fans
 - Motor generators
 - Similar units to listed above

This practice ensures correct grounding of the units.

- If an electrical accident occurs:
 - Use caution; do not become a victim yourself.
 - Switch off power.
 - Send another person to get medical aid.

Safety inspection guide

The purpose of this inspection guide is to assist you in identifying potentially unsafe conditions. As each machine was designed and built, required safety items were installed to protect users and service technicians from injury. This guide addresses only those items. You should use good judgment to identify potential safety hazards due to attachment of non-ThinkPad features or options not covered by this inspection guide.

If any unsafe conditions are present, you must determine how serious the apparent hazard could be and whether you can continue without first correcting the problem.

Consider these conditions and the safety hazards they present:

- Electrical hazards, especially primary power (primary voltage on the frame can cause serious or fatal electrical shock)
- Explosive hazards, such as a damaged CRT face or a bulging capacitor
- Mechanical hazards, such as loose or missing hardware

To determine whether there are any potentially unsafe conditions, use the following checklist at the beginning of every service task. Begin the checks with the power off, and the power cord disconnected.

Checklist:

1. Check exterior covers for damage (loose, broken, or sharp edges).
2. Power off the computer. Disconnect the power cord.
3. Check the power cord for:
 - a. A third-wire ground connector in good condition. Use a meter to measure third-wire ground continuity for 0.1 ohm or less between the external ground pin and the frame ground.
 - b. The power cord should be the type specified in the parts list.
 - c. Insulation must not be frayed or worn.
4. Check for cracked or bulging batteries.
5. Remove the cover.
6. Check for any obvious non-ThinkPad alterations. Use good judgment as to the safety of any non-ThinkPad alterations.
7. Check inside the unit for any obvious unsafe conditions, such as metal filings, contamination, water or other liquids, or signs of fire or smoke damage.
8. Check for worn, frayed, or pinched cables.
9. Check that the power-supply cover fasteners (screws or rivets) have not been removed or tampered with.

Handling devices that are sensitive to electrostatic discharge

Any computer part containing transistors or integrated circuits (ICs) should be considered sensitive to electrostatic discharge (ESD.) ESD damage can occur when there is a difference in charge between objects. Protect against ESD damage by equalizing the charge so that the machine, the part, the work mat, and the person handling the part are all at the same charge.

Notes:

1. Use product-specific ESD procedures when they exceed the requirements noted here.
2. Make sure that the ESD protective devices you use have been certified (ISO 9000) as fully effective.

When handling ESD-sensitive parts:

- Keep the parts in protective packages until they are inserted into the product.
- Avoid contact with other people.
- Wear a grounded wrist strap against your skin to eliminate static on your body.
- Prevent the part from touching your clothing. Most clothing is insulative and retains a charge even when you are wearing a wrist strap.
- Use a grounded work mat to provide a static-free work surface. The mat is especially useful when handling ESD-sensitive devices.
- Select a grounding system, such as those listed below, to provide protection that meets the specific service requirement.

Note:

The use of a grounding system to guard against ESD damage is desirable but not necessary.

- Attach the ESD ground clip to any frame ground, ground braid, or green-wire ground.
- When working on a double-insulated or battery-operated system, use an ESD common ground or reference point. You can use coax or connector-outside shells on these systems.
- Use the round ground prong of the ac plug on ac-operated computers.

Grounding requirements

Electrical grounding of the computer is required for operator safety and correct system function. Proper grounding of the electrical outlet can be verified by a certified electrician.

Safety notices (multilingual translations)

The safety notices in this section are provided in the following languages:

- English
- Arabic
- Brazilian Portuguese
- French
- German
- Hebrew
- Japanese
- Korean
- Spanish
- Traditional Chinese



DANGER

Before the computer is powered on after FRU replacement, make sure all screws, springs, and other small parts are in place and are not left loose inside the computer. Verify this by shaking the computer and listening for rattling sounds. Metallic parts or metal flakes can cause electrical shorts.



DANGER

Some standby batteries contain a small amount of nickel and cadmium. Do not disassemble a standby battery, recharge it, throw it into fire or water, or short-circuit it. Dispose of the battery as required by local ordinances or regulations. Use only the battery in the appropriate parts listing. Use of an incorrect battery can result in ignition or explosion of the battery.



DANGER

The battery pack contains small amounts of nickel. Do not disassemble it, throw it into fire or water, or short-circuit it. Dispose of the battery pack as required by local ordinances or regulations. Use only the battery in the appropriate parts listing when replacing the battery pack. Use of an incorrect battery can result in ignition or explosion of the battery.



DANGER

The lithium battery can cause a fire, an explosion, or a severe burn. Do not recharge it, remove its polarized connector, disassemble it, heat it above 100°C (212°F), incinerate it, or expose its cell contents to water. Dispose of the battery as required by local ordinances or regulations. Use only the battery in the appropriate parts listing. Use of an incorrect battery can result in ignition or explosion of the battery.



DANGER

If the LCD breaks and the fluid from inside the LCD gets into your eyes or on your hands, immediately wash the affected areas with water for at least 15 minutes. Seek medical care if any symptoms from the fluid are present after washing.



DANGER

Though the main batteries have low voltage, a shorted or grounded battery can produce enough current to burn personnel or combustible materials.



DANGER

Unless hot swap is allowed for the FRU being replaced, do as follows before removing it: power off the computer, unplug all power cords from electrical outlets, remove the battery pack, and disconnect any interconnecting cables.



خطر

قبل اعادة تشغيل الحاسب بعد الانتهاء من استبدال FRU، تأكد من أنه قد تم اعادة كل من المسامير و السوست وكل الأجزاء الصغيرة الأخرى في أماكنهم ولم يتم فقدهم داخل الحاسب. ويمكن التحقق من ذلك عن طريق هز الحاسب والاستماع لأي صوت صاخب يصدر منه. قد تؤدي الأجزاء أو الرقائق المعدنية الى حدوث دائرة قصر.



خطر

تحتوي بعض البطاريات الاحتياطية على كمية صغيرة من مادتي النيكل والكاديوم. لا تقم بفك أو اعادة شحن البطارية الاحتياطية ولا تقم أيضا بالقاءها في النار أو الماء ولا تتسبب في احدث دائرة قصر بها. قم بالتخلص من البطارية كما هو موضح في القوانين المحلية. استخدم نوع البطارية المحدد والذي يوصى باستخدامه. حيث أنه قد يؤدي استخدام نوع بطارية غير صحيح الى اشتعالها أو انفجارها.



خطر

تحتوي حزمة البطارية على كمية صغيرة من مادة النيكل. لا تقم بفكها أو القاءها في النار أو الماء ولا تتسبب في احدث دائرة قصر بها. تخلص من حزمة البطارية وفقا لما هو موضح في القوانين المحلية. قم، عند استبدال حزمة البطارية، باستخدام الأنواع المحددة فقط والتي يوصى باستخدامها. حيث أنه قد يؤدي استخدام نوع بطارية غير صحيح الى اشتعالها أو انفجارها.



خطر

قد تتسبب بطارية الليثيوم في حدوث حريق أو انفجار أو حدوث حروق شديدة. لا تقم باعادة شحن البطارية أو ازالة موصل الاستقطاب الخاص بها ولا تحاول أيضا فكها أو تسخينها لأكثر من ١٠٠ درجة مئوية (٢١٢١ فهرنهايت) أو حرقها أو تعريض محتويات الخانة الخاصة بها للماء. قم بالتخلص من البطارية وفقا لما هو موضح في القوانين المحلية. استخدم نوع البطارية المحدد والذي يوصى باستخدامه. حيث أنه قد يؤدي استخدام نوع بطارية غير صحيح الى اشتعالها أو انفجارها.



خطر

إذا ما انكسرت شاشة LCD ولامس السائل الداخلي عينيك أو يديك، قم في الحال بغسلهما بالماء لمدة لا تقل عن ١٥ دقيقة. إذا ما وجدت أي أعراض بعد الغسل اطلب عندئذ المساعدة الطبية.



خطر

على الرغم من أن البطاريات الرئيسية يكون لها جهد منخفض، إلا أنه قد تقوم البطاريات التي حدث قصور بها أو التي تم توصيلها أرضيا بإصدار تيار يكفي لحدوث حروق للأفراد أو تعرض المواد القابلة للاشتعال للحريق.



خطر

ما لم يتم السماح بالتبديل الفوري لأي FRU الجاري استبداله بدون ضرورة اغلاق النظام، قم بتنفيذ ما يلي قبل ازالته. قم بإيقاف تشغيل الحاسب ونزع كل أسلاك الطاقة من المخارج الكهربائية وقم أيضا بإزالة حزمة البطارية ثم قم بفصل أي كابلات متصلة.



PERIGO

Antes de ligar o computador após a substituição da FRU, certifique-se de que todos os parafusos, molas e outras peças pequenas estejam no lugar e não estejam soltos dentro do computador. Verifique isso sacudindo o computador e procurando ouvir sons de peças soltas. Peças metálicas ou lascas de metal podem causar curto-circuito.



PERIGO

Algumas baterias reserva contêm uma pequena quantidade de níquel e cádmio. Não desmonte uma bateria reserva, recarregue-a, jogue-a no fogo ou na água, ou deixe-a entrar em curto-circuito. Descarte a bateria conforme requerido pelas leis ou regulamentos locais. Use somente a bateria nas partes listadas apropriadas. O uso de uma bateria incorreta pode resultar em combustão ou explosão da bateria.



PERIGO

O pacote da bateria contém uma pequena quantidade de níquel. Não o desmonte, jogue-o no fogo ou na água, ou deixe-o entrar em curto-circuito. Descarte o pacote da bateria conforme requerido pelas leis ou regulamentos locais. Use somente a bateria nas partes listadas apropriadas ao substituir o pacote da bateria. O uso de uma bateria incorreta pode resultar em combustão ou explosão da bateria.



PERIGO

A bateria de lítio pode causar incêndio, explosão ou graves queimaduras. Não a recarregue, remova seu conector polarizado, desmonte-a, aqueça-a acima de 100°C (212°F), incinere-a, ou exponha o conteúdo de sua célula à água. Descarte a bateria conforme requerido pelas leis ou regulamentos locais. Use somente a bateria nas partes listadas apropriadas. O uso de uma bateria incorreta pode resultar em combustão ou explosão da bateria.



PERIGO

Se o LCD quebrar e o fluido de dentro dele entrar em contato com seus olhos ou com suas mãos, lave as áreas afetadas imediatamente com água durante pelo menos 15 minutos. Procure cuidados médicos se algum sintoma causado pelo fluido surgir após a lavagem.



PERIGO

Embora as principais baterias possuam baixa voltagem, uma bateria em curto-circuito ou aterrada pode produzir corrente o bastante para queimar materiais de pessoal ou inflamáveis.



PERIGO

A menos que uma hot swap seja permitida para a FRU que está sendo substituída, faça o seguinte antes de removê-la: desligue o computador, desconecte todos os cabos de energia das tomadas, remova o pacote de baterias e desconecte quaisquer cabos de interconexão.



DANGER

Avant de remettre l'ordinateur sous tension après remplacement d'une unité en clientèle, vérifiez que tous les ressorts, vis et autres pièces sont bien en place et bien fixées. Pour ce faire, secouez l'unité et assurez-vous qu'aucun bruit suspect ne se produit. Des pièces métalliques ou des copeaux de métal pourraient causer un court-circuit.



DANGER

Certaines batteries de secours contiennent du nickel et du cadmium. Ne les démontez pas, ne les rechargez pas, ne les exposez ni au feu ni à l'eau. Ne les mettez pas en court-circuit. Pour les mettre au rebut, conformez-vous à la réglementation en vigueur. Lorsque vous remplacez la pile de sauvegarde ou celle de l'horloge temps réel, veillez à n'utiliser que les modèles cités dans la liste de pièces détachées adéquate. Une batterie ou une pile inappropriée risque de prendre feu ou d'exploser.



DANGER

La batterie contient du nickel. Ne la démontez pas, ne l'exposez ni au feu ni à l'eau. Ne la mettez pas en court-circuit. Pour la mettre au rebut, conformez-vous à la réglementation en vigueur. Lorsque vous remplacez la batterie, veillez à n'utiliser que les modèles cités dans la liste de pièces détachées adéquate. En effet, une batterie inappropriée risque de prendre feu ou d'exploser.



DANGER

La pile de sauvegarde contient du lithium. Elle présente des risques d'incendie, d'explosion ou de brûlures graves. Ne la rechargez pas, ne retirez pas son connecteur polarisé et ne la démontez pas. Ne l'exposez pas à une température supérieure à 100°C, ne la faites pas brûler et n'en exposez pas le contenu à l'eau. Mettez la pile au rebut conformément à la réglementation en vigueur. Une pile inappropriée risque de prendre feu ou d'exploser.



DANGER

Si le panneau d'affichage à cristaux liquides se brise et que vous recevez dans les yeux ou sur les mains une partie du fluide, rincez-les abondamment pendant au moins quinze minutes. Consultez un médecin si des symptômes persistent après le lavage.



DANGER

Bien que le voltage des batteries principales soit peu élevé, le court-circuit ou la mise à la masse d'une batterie peut produire suffisamment de courant pour brûler des matériaux combustibles ou causer des brûlures corporelles graves.



DANGER

Si le remplacement à chaud n'est pas autorisé pour l'unité remplaçable sur site que vous remplacez, procédez comme suit avant de retirer l'unité : mettez l'ordinateur hors tension, débranchez tous les cordons d'alimentation des prises de courant, retirez le bloc de batterie et déconnectez tous les câbles d'interconnexion.



VORSICHT

Bevor nach einem FRU-Austausch der Computer wieder angeschlossen wird, muß sichergestellt werden, daß keine Schrauben, Federn oder andere Kleinteile fehlen oder im Gehäuse vergessen wurden. Der Computer muß geschüttelt und auf Klappergeräusche geprüft werden. Metallteile oder-splitter können Kurzschlüsse erzeugen.



VORSICHT

Die Bereitschaftsbatterie, die sich unter dem Diskettenlaufwerk befindet, kann geringe Mengen Nickel und Cadmium enthalten. Sie darf nur durch die Verkaufsstelle oder den IBM Kundendienst ausgetauscht werden. Sie darf nicht zerlegt, wiederaufgeladen, kurzgeschlossen, oder Feuer oder Wasser ausgesetzt werden. Die Batterie kann schwere Verbrennungen oder Verätzungen verursachen. Bei der Entsorgung die örtlichen Bestimmungen für Sondermüll beachten. Beim Ersetzen der Bereitschafts-oder Systembatterie nur Batterien des Typs verwenden, der in der Ersatzteilliste aufgeführt ist. Der Einsatz falscher Batterien kann zu Entzündung oder Explosion führen.



VORSICHT

Akkus enthalten geringe Mengen von Nickel. Sie dürfen nicht zerlegt, wiederaufgeladen, kurzgeschlossen, oder Feuer oder Wasser ausgesetzt werden. Bei der Entsorgung die örtlichen Bestimmungen für Sondermüll beachten. Beim Ersetzen der Batterie nur Batterien des Typs verwenden, der in der Ersatzteilliste aufgeführt ist. Der Einsatz falscher Batterien kann zu Entzündung oder Explosion führen.



VORSICHT

Die Systembatterie ist eine Lithiumbatterie. Sie kann sich entzünden, explodieren oder schwere Verbrennungen hervorrufen. Batterien dieses Typs dürfen nicht aufgeladen, zerlegt, über 100 C erhitzt oder verbrannt werden. Auch darf ihr Inhalt nicht mit Wasser in Verbindung gebracht oder der zur richtigen Polung angebrachte Verbindungsstecker entfernt werden. Bei der Entsorgung die örtlichen Bestimmungen für Sondermüll beachten. Beim Ersetzen der Batterie nur Batterien des Typs verwenden, der in der Ersatzteilliste aufgeführt ist. Der Einsatz falscher Batterien kann zu Entzündung oder Explosion führen.



VORSICHT

Die Leuchtstoffröhre im LCD-Bildschirm enthält Quecksilber. Bei der Entsorgung die örtlichen Bestimmungen für Sondermüll beachten. Der LCD-Bildschirm besteht aus Glas und kann zerbrechen, wenn er unsachgemäß behandelt wird oder der Computer auf den Boden fällt. Wenn der Bildschirm beschädigt ist und die darin befindliche Flüssigkeit in Kontakt mit Haut und Augen gerät, sollten die betroffenen Stellen mindestens 15 Minuten mit Wasser abgespült und bei Beschwerden anschließend ein Arzt aufgesucht werden.



VORSICHT

Obwohl Hauptbatterien eine niedrige Spannung haben, können sie doch bei Kurzschluß oder Erdung genug Strom abgeben, um brennbare Materialien zu entzünden oder Verletzungen bei Personen hervorzurufen.



VORSICHT

Wenn ein Austausch der FRU bei laufendem Betrieb nicht erlaubt ist, gehen Sie beim Austausch der FRU wie folgt vor: Schalten Sie den Computer aus, ziehen Sie alle Netzkabel von den Netzsteckdosen ab, entfernen Sie den Akku und ziehen Sie alle miteinander verbundenen Kabel ab.



סכנה

לפני הפעלת המחשב לאחר החלפת FRU יש לוודא שכל הברגים, הקפיצים, וחלקים קטנים אחרים נמצאים במקומם ואינם חופשיים לזוז בתוך המחשב. כדי לוודא זאת, יש לטלטל את המחשב ולחקשבו לגילוי קולות שקשוק. חלקי או שבבי מתכת עלולים לגרום לקצרים חשמליים.



סכנה

סוללות המתנה מסוימות מכילות כמות קטנה של ניקל וקדמיום. אין לפרק סוללת המתנה, לטעון אותה מחדש, להשליך אותה לאש או למים או לקצר אותה. יש לסלק את הסוללה כנדרש על ידי התקנות והחוקים המקומיים. יש להשתמש רק בסוללה המופיעה ברשימת החלקים המתאימה. שימוש בסוללה לא מתאימה עלול לגרום להצתה או התפוצצות של הסוללה.



סכנה

מארז הסוללה מכיל כמות קטנה של ניקל וקדמיום. אין לפרק את מארז הסוללה, להשליך אותו לאש או למים או לקצר אותו. יש לסלק את מארז הסוללה כנדרש על ידי התקנות והחוקים המקומיים. יש להשתמש רק בסוללה המופיעה ברשימת החלקים המתאימה בזמן החלפת מארז הסוללה. שימוש בסוללה לא מתאימה עלול לגרום להצתה או התפוצצות של הסוללה.



סכנה

סוללת הליתיום עלולה לגרום לשריפה, להתפוצצות או לכוויות קשות. אין לטעון אותה מחדש, לסלק את המחבר המקוטב שלה, לפרק אותה או לחמם אותה לטמפרטורה העולה על 100 מעלות צלזיוס. אין לשרוף את הסוללה ואין לחשוף את תוכן התא למים. יש לסלק את הסוללה כנדרש בתקנות ובחוקים המקומיים. יש להשתמש רק בסוללה המופיעה ברשימת החלקים המתאימים. שימוש בסוללה אחרת עלול לגרום לסכנת שריפה או התפוצצות.



סכנה

אם מסך הגביש הנוזלי (LCD) נשבר והנוזל מתוך המסך בא במגע עם עיניכם או ידיכם, שטפו את האזורים הנגועים מייד במים במשך 15 דקות לפחות. פנו לקבלת עזרה רפואית אם תסמינים הנובעים מחמגע עם הנוזל נמשכים לאחר חטיפה.



סכנה

אף שהסוללות הראשיות הן בעלות מתח נמוך, סוללה מקוצרת או מוארכת עלולה להפיק זרם מספיק לגרימת כוויות או להצתת חומרים דליקים.



סכנה

אלא אם כן מותרת 'החלפה חמה' של ה-FRU המוחלף, פעלו כדלהלן לפני הסרתו: כבו את המחשב, נתקו את כל כבלי החשמל מהשקעים, הוציאו את מארז הסוללות ונתקו את כל הכבלים המחוברים.



危険

FRUの交換後、ThinkPadの電源を入れる前に、ねじ、バネ、その他の小さな部品がすべて正しい位置にあり、またThinkPadの内部で緩んでいないことを確認してください。
これを確認するには、ThinkPadを振って、カチャカチャと音がしないか確かめます。金属部品や金属破片はショートの原因になることがあります。



危険

予備バッテリーの中には少量のニッケルとカドミウムが含まれているものがあります。したがって、予備バッテリーの分解、再充電、火または水の中への投棄、またはショートさせることは決して行わないでください。バッテリーを廃棄する場合は地方自治体の条例に従ってください。適切なパーツ・リストにあるバッテリーだけを使用してください。誤ったバッテリーを使用すると、バッテリーが発火したり、爆発したりすることがあります。



危険

バッテリー・パックには少量のニッケルが含まれています。バッテリー・パックを分解したり、火または水の中に投げ込んだり、ショートさせないでください。バッテリー・パックの廃棄にあたっては、地方自治体の条例または規則に従ってください。バッテリー・パックを交換するときは、適切なパーツ・リストにあるバッテリーだけを使用してください。誤ったバッテリーを使用すると、バッテリーが発火したり、爆発したりすることがあります。



危険

リチウム・バッテリーは、火災、爆発、または重症のやけどを引き起こすことがあります。バックアップ・バッテリーの充電、その極性コネクターの取り外し、バッテリー本体の分解、100 °C (212 °F) 以上への加熱、焼却、電池の中身を水に浸すことはしないでください。バッテリーを廃棄する場合は地方自治体の条例に従ってください。適切なパーツ・リストにあるバッテリーだけを使用してください。誤ったバッテリーを使用すると、バッテリーが発火したり、爆発したりすることがあります。



危険

LCDが破損し、LCDの中の液体が目に入ったり、手に触れたりした場合は、液体が触れた部分を少なくとも15分間洗い流してください。洗い流した後に、液体によって何らかの症状が現れた場合は、医師の治療を受けてください。



危険

メイン・バッテリーの電圧は低くても、ショートしたり、接地したバッテリーが、作業者にやけどを負わせたり、可燃物を燃やすだけの電流を発生させる場合があります。



危険

交換しようとしている FRU がホット・スワップに対応していない場合、それを取り外す前に、コンピューターの電源をオフにし、すべての電源コードをコンセントから抜き、バッテリー・パックを取り外して、相互接続しているケーブルをすべて切り離してください。



위험

FRU를 교체하고 나서 컴퓨터 전원을 켜기 전에 모든 나사, 스프링 및 기타 작은 부품들이 올바른 위치에 있는지, 컴퓨터 내부에 단단하게 연결되어 있는지 확인하십시오. 컴퓨터를 흔들어 달각거리는 소리가 나지 않는지 확인하십시오. 금속 부품 또는 금속 조각은 누전을 일으킬 수 있습니다.



위험

일부 보조 배터리에는 소량의 니켈 및 카트륨이 포함되어 있습니다. 보조 배터리를 분해하거나, 다시 충전하거나, 불 또는 물에 던지거나, 단락시키지 마십시오. 배터리 팩을 폐기할 때에는 해당 지역의 법률 규정을 따르십시오. 배터리 팩을 교체할 때에는 올바른 배터리만 사용하십시오. 올바르지 않은 배터리를 사용하면 배터리가 발화되거나 폭발할 수 있습니다.



위험

배터리 팩에는 소량의 니켈이 포함되어 있습니다. 배터리 팩을 분해하거나, 불 또는 물에 던지거나, 단락시키지 마십시오. 배터리 팩을 폐기할 때에는 해당 지역의 법률 규정을 따르십시오. 배터리 팩을 교체할 때에는 올바른 배터리만 사용하십시오. 올바르지 않은 배터리를 사용하면 배터리가 발화되거나 폭발할 수 있습니다.



위험

리튬 배터리는 화재, 폭발 또는 심각한 화상을 일으킬 수 있습니다. 리튬 배터리를 다시 충전하거나, 극성 커넥터를 제거하거나, 분해하거나, 100C(212F) 이상으로 가열하거나, 소각하거나, 전지 내용물을 물에 노출시키지 마십시오. 배터리를 폐기할 때에는 해당 지역을 법률 규정을 따르십시오. 올바른 배터리만 사용하십시오. 올바르지 않은 배터리를 사용하면 배터리가 발화되거나 폭발할 수 있습니다.



위험

LCD가 파손되어 LCD 내부의 액체가 눈에 들어가거나 손에 묻으면 즉시 깨끗한 물로 15분 이상 닦아 내십시오. 씻은 후에 조금이라도 이상을 느끼면 즉시 병원에 가서 의사의 진찰을 받아야 합니다.



위험

기본 배터리의 전압은 낮지만, 단락되거나 접지된 배터리는 화상을 입히기에 충분한 전류와 가연성 물질을 발생시킬 수 있습니다.



위험

FRU 교체 시 Hot Swap이 지원되지 않는 경우, FRU를 제거하기 전에 컴퓨터의 전원을 끄고, 전기 콘센트에서 전원 코드를 분리하고, 배터리를 제거한 후, 연결된 모든 케이블을 분리하십시오.



PELIGRO

Antes de encender el sistema después de sustituir una FRU, compruebe que todos los tornillos, muelles y demás piezas pequeñas se encuentran en su sitio y no se encuentran sueltas dentro del sistema. Compruébelo agitando el sistema y escuchando los posibles ruidos que provocarían. Las piezas metálicas pueden causar cortocircuitos eléctricos.



PELIGRO

Algunas baterías de reserva contienen una pequeña cantidad de níquel y cadmio. No las desmonte, ni recargue, ni las eche al fuego o al agua ni las cortocircuite. Deséchelas tal como dispone la normativa local. Utilice sólo baterías que se encuentren en la lista de piezas. La utilización de una batería no apropiada puede provocar la ignición o explosión de la misma.



PELIGRO

Las baterías contienen pequeñas cantidades de níquel. No las desmonte, ni recargue, ni las eche al fuego o al agua ni las cortocircuite. Deséchelas tal como dispone la normativa local. Utilice sólo baterías que se encuentren en la lista de piezas al sustituir la batería. La utilización de una batería no apropiada puede provocar la ignición o explosión de la misma.



PELIGRO

La batería de repuesto es una batería de litio y puede provocar incendios, explosiones o quemaduras graves. No la recargue, ni quite el conector polarizado, ni la desmonte, ni caliente por encima de los 100°C (212°F), ni la incinere ni exponga el contenido de sus celdas al agua. Deséchela tal como dispone la normativa local.



PELIGRO

Si la LCD se rompe y el fluido de su interior entra en contacto con sus ojos o sus manos, lave inmediatamente las áreas afectadas con agua durante 15 minutos como mínimo. Obtenga atención médica si se presenta algún síntoma del fluido después de lavarse.



PELIGRO

Aunque las baterías principales tienen un voltaje bajo, una batería cortocircuitada o con contacto a tierra puede producir la corriente suficiente como para quemar material combustible o provocar quemaduras en el personal.



PELIGRO

Salvo que se permita el intercambio en caliente para la unidad sustituible localmente, realice lo siguiente antes de extraerla: apague el sistema, desconecte todos los cables de alimentación de las tomas de alimentación eléctrica, extraiga la batería y desconecte los cables de interconexión.



危險

完成 FRU 更換之後，在開啟電腦的電源之前，請確定所有螺絲、彈簧及其他小零件都已歸位，沒有遺留在電腦內部。
若要確認這一點，請搖晃電腦，聽聽看是否有卡嗒的聲響。
金屬零件或儀錶的火花會造成電線短路。



危險

部分備用電池含有微量的鎳和鎘。請勿拆開備用電池、再充電、丟入火或水中，或使其形成短路。請按照當地法令或規定來棄置電池。
僅限使用零件清單中的電池。使用不適當的電池會導致電池起火或爆炸。



危險

電池套件含有微量的鎳。請勿拆開電池套件、丟入火或水中，或使其形成短路。請按照當地法令或規定來棄置電池套件。
更換電池套件時，僅限使用零件清單中的電池。使用不適當的電池會導致電池起火或爆炸。



危險

鋰電池會導致起火、爆炸或嚴重燒傷。請勿再充電、拔除其電極接頭、拆開、加熱超過 **100°C (212°F)**、焚燒，或讓電池組成物浸到水。請按照當地法令或規定來棄置電池。
僅限使用零件清單中的電池。使用不適當的電池會導致電池起火或爆炸。



危險

如果 LCD 破裂導致 LCD 流出的液體沾到您的眼睛或手，請立即以清水沖洗沾染部位至少 15 分鐘。如果在清洗後出現該液體所造成的任何症狀，請就醫治療。



危險

雖然主電池的電壓很低，但短路或接地電池所產生的電流，仍足以使人燒傷或使可燃物質起火。



危險

除非 FRU 允許以熱抽換來替換，否則請依下列方式將其移除：將電腦關機，拔除插座上所有電源線，移除電池包，並拔開任何交互連接的線材。

Important service information

This chapter presents following important service information that applies to all machine types supported by this manual:

- “Strategy for replacing FRUs” on page 30
 - “Strategy for replacing a hard disk drive” on page 30
 - “Important notice for replacing a system board” on page 31
 - “How to use error message” on page 31
- “Strategy for replacing FRUs for CTO, CMV, and GAV” on page 32
 - “Product definition” on page 32
 - “FRU identification for CTO, CMV, and GAV products” on page 32

Important:

BIOS and device driver fixes are customer-installable. The BIOS and device drivers are posted on the customer support site <http://www.lenovo.com/support>

System Disassembly/Reassembly videos that show the FRU removals or replacements for the Lenovo® authorized service technicians are available in the following support site: <http://www.lenovoservicetraining.com/ion/>

Advise customers to contact the Customer Support Center at 800-426-7378 if they need assistance in obtaining or installing any software fixes, drivers, and BIOS downloads.

Customers in Canada should call the Customer Support Center at 800-565-3344 for assistance or download information.

Customers in other countries can contact their Customer Support Centers at <http://www-307.ibm.com/pc/support/site.wss/document.do?lnocid=MIGR-4HWSE3>

Strategy for replacing FRUs

Before replacing parts:

Make sure that all software fixes, drivers, and BIOS downloads are installed before replacing any FRUs listed in this manual.

After a system board is replaced, ensure that the latest BIOS is loaded to the system board before completing the service action.

To download software fixes, drivers, and BIOS, do as follows:

1. Go to <http://www.lenovo.com/support>
2. Enter the product number of the computer or press Auto-detect button on the screen.
3. Select **Downloads and drivers**.
4. Follow the directions on the screen and install the necessary software.

Use the following strategy to prevent unnecessary expense for replacing and servicing FRUs:

- **If you are instructed to replace a FRU but the replacement does not correct the problem, reinstall the original FRU before you continue.**
- Some computers have both a processor board and a system board. If you are instructed to replace either the processor board or the system board, and replacing one of them does not correct the problem, reinstall that board, and then replace the other one.
- If an adapter or a device consists of more than one FRU, any of the FRUs may be the cause of the error. Before replacing the adapter or device, remove the FRUs, one by one, to see if the symptoms change. Replace only the FRU that changed the symptoms.

Attention: The setup configuration on the computer you are servicing may have been customized. Running Automatic Configuration may alter the settings. Note the current configuration settings (using the View Configuration option); then, when service has been completed, verify that those settings remain in effect.

Strategy for replacing a hard disk drive

Always try to run a low-level format before replacing a hard disk drive. This will cause all customer data on the hard disk to be lost. Be sure that the customer has a current backup of the data before doing this task.

Attention: The drive startup sequence in the computer you are servicing may have been changed. Be extremely careful during write operations such as copying, saving, or formatting. If you select an incorrect drive, data or programs can be overwritten.

Important notice for replacing a system board

Some components mounted on a system board are very sensitive. Improper handling of a system board can cause damage to those components, and may cause a system malfunction.

Attention: When handling a system board:

- Do not drop a system board or apply any excessive force to it.
- Avoid rough handling of any kind.
- Avoid bending a system board and hard pushing to prevent cracking at each BGA (Ball Grid Array) chipset.

How to use error message

Use the error codes displayed on the screen to diagnose failures. If more than one error code is displayed, begin the diagnosis with the first error code. Whatever causes the first error code may also cause false error codes. If no error code is displayed, see whether the error symptom is listed in the Symptom-to-FRU Index for the computer you are servicing.

Strategy for replacing FRUs for CTO, CMV, and GAV

Product definition

Dynamic Configure To Order (CTO)

This provides the ability for a customer to configure an IBM® or a Lenovo solution from an eSite, and have this configuration sent to fulfillment, where it is built and shipped directly to the customer. The machine label, Product Entitlement Warehouse (PEW), eSupport, and the HMM will load these products as the 4-digit MT and 3-digit model, where model = "CTO" (Example: 1829-CTO).

Custom Model Variant (CMV)

This is a unique configuration that has been negotiated between IBM or Lenovo and the customer. A unique 4-digit MT and 3-digit model is provided to the customer to place orders (Example: 1829-W15). A CMV is a special bid offering. Therefore, it is NOT generally announced.

- The MTM portion of the machine label is the 4-digit MT and 3-digit model, where model = "CTO" (Example: 1829-CTO). The PRODUCT ID portion of the machine label is the 4-digit MT and 3-digit CMV model (Example: 1829-W15).
- The PEW record is the 4-digit MT and 3-digit model, where model = "CTO" (Example: 1829-CTO).
- eSupport will show both the CTO and CMV machine type models (Example: 1829-CTO and 1829-W15 will be found on the eSupport site.)
- The HMM will have the 4-digit MT and 3-digit CTO model only (Example: 1829-CTO). Again, CMVs are custom models and are not found in the HMM.

General Announce Variant (GAV)

This is a standard model (fixed configuration). GAVs are announced and offered to all customers. The MTM portion of the machine label is a 4-digit MT and 3-digit model, where model = a "fixed part number", not "CTO" (Example: 1829-F1U). Also, PEW, eSupport, and the HMM will list these products under the same fixed model number.

FRU identification for CTO, CMV, and GAV products

There are three information resources to identify which FRUs are used to support CTO, CMV, and GAV products. These sources are PEW, eSupport, and the HMM.

Using PEW

- PEW is the primary source for identifying FRU part numbers and FRU descriptions for the key commodities for CTO, CMV and GAV products at a MT - serial number level. An example of key commodities are hard disk drives, system boards, microprocessors, Liquid Crystal Displays (LCDs), and memory.
- Remember, all CTO and CMV products are loaded in PEW under the 4-digit MT and 3-digit model, where model = "CTO" (Example: 1829-CTO). GAVs are loaded in PEW under the 4-digit MT and 3-digit model, where model = a "fixed part number", not "CTO" (Example: 1829-F1U).
- PEW can be accessed at the following Web site:
<http://www.lenovo.com/support/site.wss/document.do?lndocid=LOOK-WARNTY>
Select Warranty lookup. Input the MT and the Serial number and the list of key commodities will be returned in the PEW record under COMPONENT INFORMATION.

- **Business Partners** using Eclaim will access PEW when performing Entitlement Lookup. Business Partners will enter Loc ID, MT and Serial, and the key commodities will be returned in the Eclaim record under SYSTEM DETAILS.
- Authorized IBM Business Partners can access Eclaim at the following Web site: <https://wca.eclaim.com>

Using eSupport

For Key Commodities (Examples - hard disk drive, system board, microprocessor, LCD, and memory)

- eSupport can be used to view the list of key commodities built in a particular machine serial (this is the same record found in PEW).
- eSupport can be accessed at the following Web site: <http://www.lenovo.com/support>
- To view the key commodities, click on PARTS INFORMATION, then PARTS LOOKUP. Type in the model type and serial number. The key commodities will be returned in the eSupport record under PARTS SHIPPED WITH YOUR SYSTEM.

For the Remaining FRUs (the complete list of FRUs at the MT Model level)

- eSupport can be used to view the complete list of FRUs for a machine type and model.
- To view the complete list of FRUs, type in the machine type and model (Example: 1829-CTO) under QUICK PATH. Under "View by Document Type" select PARTS INFORMATION. Under "Filter by Category" select SERVICE PARTS. Under "Parts Information by Date" select SYSTEM SERVICE PARTS. The list of service parts by description, with applicable machine type model and FRU will be displayed.

Using the HMM

For Key Commodities (Examples - hard disk drive, system board, microprocessor, LCD, and memory)

Use the HMM as a back-up to PEW and eSupport to view the complete list of FRUs at the MT Model level.

General checkout

This chapter presents following information:

- “What to do first” on page 36
- “Checkout guide” on page 37
 - “Diagnostics using PC-Doctor for DOS” on page 37
 - “Lenovo ThinkVantage Toolbox (Lenovo System Toolbox)” on page 40
 - “PC-Doctor for Rescue and Recovery” on page 40
 - “FRU tests” on page 41
- “Power system checkout” on page 43

The descriptions in this chapter apply to any ThinkPad model that supports the PC-Doctor® for DOS diagnostics program. Some descriptions might not apply to your particular computer.

Before you go to the checkout guide, be sure to read the following important notes.

Important notes:

- **Only certified trained personnel should service the computer.**
- **Before replacing any FRU, read the entire page on removing and replacing FRUs.**
- **When you replace FRUs, use new nylon-coated screws.**
- **Be extremely careful during such write operations as copying, saving, or formatting.** Drives in the computer that you are servicing sequence might have been altered. If you select an incorrect drive, data or programs might be overwritten.
- **Replace a FRU only with another FRU of the correct model.** When you replace a FRU, make sure that the model of the machine and the FRU part number are correct by referring to the FRU parts list.
- **A FRU should not be replaced because of a single, unreproducible failure.** Single failures can occur for a variety of reasons that have nothing to do with a hardware defect, such as cosmic radiation, electrostatic discharge, or software errors. Consider replacing a FRU only when a problem recurs. If you suspect that a FRU is defective, clear the error log and run the test again. If the error does not recur, do not replace the FRU.
- **Be careful not to replace a nondefective FRU.**

What to do first

When you do return a FRU, you must include the following information in the parts exchange form or parts return form that you attach to it:

- ___ 1. Name and phone number of service technician
- ___ 2. Date of service
- ___ 3. Date on which the machine failed
- ___ 4. Date of purchase
- ___ 5. Failure symptoms, error codes appearing on the display, and beep symptoms
- ___ 6. Procedure index and page number in which the failing FRU was detected
- ___ 7. Failing FRU name and part number
- ___ 8. Machine type, model number, and serial number
- ___ 9. Customer's name and address

Note for warranty: During the warranty period, the customer may be responsible for repair costs if the computer damage was caused by misuse, accident, modification, unsuitable physical or operating environment, or improper maintenance by the customer.

Following is a list of some common items that are not covered under warranty and some symptoms that might indicate that the system was subjected to stress beyond normal use.

Before checking problems with the computer, determine whether the damage is covered under the warranty by referring to the following list:

The following are not covered under warranty:

- LCD panel cracked from the application of excessive force or from being dropped
- Scratched (cosmetic) parts
- Distortion, deformation, or discoloration of the cosmetic parts
- Plastic parts, latches, pins, or connectors that have been cracked or broken by excessive force
- Damage caused by liquid spilled into the system
- Damage caused by the improper insertion of a PC Card or the installation of an incompatible card
- Improper disc insertion or use of an optical drive
- Diskette drive damage caused by pressure on the diskette drive cover, foreign material in the drive, or the insertion of a diskette with multiple labels
- Damaged or bent diskette eject button
- Fuses blown by attachment of a nonsupported device
- Forgotten computer password (making the computer unusable)
- Sticky keys caused by spilling a liquid onto the keyboard
- Use of an incorrect AC adapter on laptop products

The following symptoms might indicate damage caused by nonwarranted activities:

- Missing parts might be a symptom of unauthorized service or modification.
- If the spindle of a hard disk drive becomes noisy, it may have been subjected to excessive force, or dropped.

Checkout guide

Use the following procedures as a guide in identifying and correcting problems with the ThinkPad Notebook.

Note: The diagnostic tests are intended to test only ThinkPad products. The use of non-ThinkPad products, prototype cards, or modified options can lead to false indications of errors and invalid system responses.

1. Identify the failing symptoms in as much detail as possible.
2. Verify the symptoms. Try to re-create the failure by running the diagnostic test or by repeating the operation.

Diagnostics using PC-Doctor for DOS

The ThinkPad Notebook has a test program called PC-Doctor for DOS (hereafter called *PC-Doctor*.) You can detect errors by running the diagnostics test included in PC-Doctor.

Note:

PC-Doctor for DOS is available at the following Web site: <http://www.lenovo.com/support>

To create the PC-Doctor diagnostic CD, follow the instructions on the Web site.

For some possible configurations of the computer, PC-Doctor might not run correctly. To avoid this problem, you need to initialize the computer setup by use of the BIOS Setup Utility before you run PC-Doctor.

To enter BIOS Setup Utility, do as follows:

1. Turn on the computer.
2. When the ThinkPad logo comes up, immediately press F1 to enter the BIOS Setup Utility.

Note: If a supervisor password has been set by the customer, BIOS Setup Utility menu appears after the password is entered. You can start the utility by pressing Enter instead of entering the supervisor password; however, you cannot change the parameters that are protected by the supervisor password.

On the BIOS Setup Utility screen, press F9, Enter, F10, and then Enter.

Note: When you initialize the computer configuration, some devices are disabled, such as the serial port. If you test one of these devices, you will need to enable it by using Configuration utility for DOS. The utility is available on the following Web site: <http://www.lenovo.com/support>

PC-Doctor cannot be used to test a device that is in the docking station, even if the computer supports the docking station. To test a USB device, connect it to the USB connector of the computer.

Testing the computer

In this product, you need an external optical drive to use the PC-Doctor diagnostic CD to test the hardware features.

Note: The PC-Doctor diagnostic CD does not support any external optical drives connected through USB devices or any others.

To run the test, do as follows:

1. Turn off the computer.
2. Attach an external optical drive through the USB connector to the computer.
3. Set the external optical drive as a startup device.
4. Turn off the computer.
5. Turn on the computer.

If the computer cannot be powered on, go to “Power system checkout” on page 43, and check the power sources.

If an error code appears, go to “Symptom-to-FRU index” on page 53.

6. When the ThinkPad logo comes up, immediately press F12 to enter the Boot Menu.
7. Insert the PC-Doctor CD into the external optical drive.
8. Press cursor keys to select **ATAPI CDx** (x: 0, 1, ...) and then press Enter.
9. Follow the instructions on the screen.
10. The main panel of PC-Doctor appears.
11. Select **Diagnostics** with the arrow keys, and press Enter.

Note: You can select an item not only with the arrow keys, but also with the TrackPoint® pointer. Instead of pressing Enter, click the left button.

A pull-down menu appears. (Its exact form depends on the model.)

Note: PC-Doctor menu does not mean the formal support device list. Some unsupported device names may appear in the PC-Doctor menu.

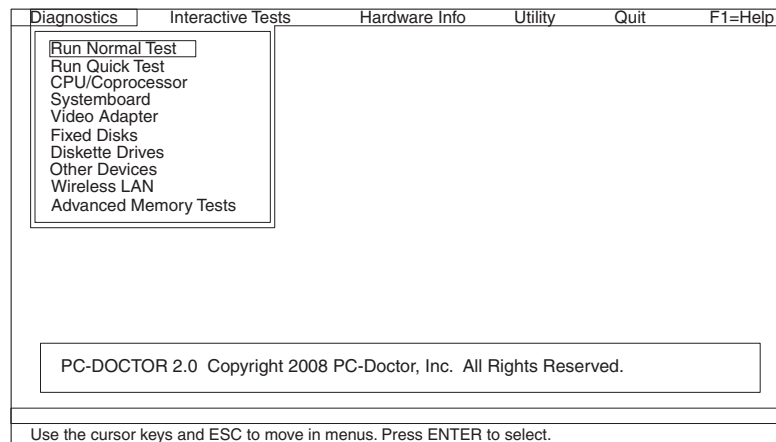

The options on the test menu are as follows:

Diagnostics	Interactive Tests
<ul style="list-style-type: none"> • Run Normal Test • Run Quick Test • CPU/Coprocessor • System board • Video Adapter • Fixed Disks • Diskette Drives • Other Devices • Wireless LAN • Advanced Memory Tests 	<ul style="list-style-type: none"> • Keyboard • Video • Internal Speaker • Mouse • Diskette • System Load • Optical Drive Test • Intel WLAN Radio Test
<p>Note:</p> <ul style="list-style-type: none"> • In the Keyboard test in Interactive Tests, the Fn key should be held down for at least 2 seconds; otherwise, it cannot be sensed. • Video Adapter test supports only the LCD display on the ThinkPad Notebook. If you have an external monitor attached to your computer, detach it before running PC-Doctor for DOS. • To test Digital Signature Chip, the security chip must be set to Active. 	

12. Run the applicable function test.
13. Follow the instructions on the screen. If there is a problem, PC-Doctor shows messages describing it.
14. To exit the test, select **Quit — Exit Diag.**
To cancel the test, press Esc.

Note: After running PC-Doctor, check the time and date on the system and reset them if they are incorrect.

Detecting system information with PC-Doctor

PC-Doctor can detect the following system information:

Hardware Info

- System Configuration
- Memory Contents
- Physical Disk Drives
- Logical Disk Drives
- VGA Information
- IDE Drive Info
- PCI Information
- PNPISA Info
- SMBIOS Info
- VESA LCD Info
- Hardware Events Log

Utility

- Run External Tests
- Surface Scan Hard Disk
- Benchmark System
- DOS Shell
- Tech Support Form
- Battery Rundown
- View Test Log

- Print Log
- Save Log
- Full Erase Hard Drive
- Quick Erase Hard Drive

Lenovo ThinkVantage Toolbox (Lenovo System Toolbox)

Lenovo ThinkVantage® Toolbox is a diagnostic program that works through the Windows operating system. It enables you to view symptoms of computer problems and solutions for them, and includes automatic notification when action is required, computing assistance, advanced diagnostics, and diagnostic history.

Note:

The latest Lenovo ThinkVantage Toolbox is available at the following Web site:
<http://www.lenovo.com/support>

To install the latest Lenovo ThinkVantage Toolbox on the computer, follow the instructions on the Web site.

To run this program, do as follows:

Click **Start --> Control Panel --> System and Security --> Lenovo's System Health and Diagnostics.**

Follow the instructions on the screen. Lenovo ThinkVantage Toolbox (Lenovo System Toolbox) also has problem determination aids that determine software and usage problems.

For additional information about this program, see the Help for the program.

PC-Doctor for Rescue and Recovery

By using PC-Doctor from the Rescue and Recovery® workspace, you can diagnose the hardware features of the computer without starting up the operating system.

To run the test, do as follows:

1. Power off the computer, and then power it on again.
2. When the ThinkPad logo comes up, immediately press **Enter** key. The Rescue and Recovery workspace opens.
3. Click **Launch advanced Rescue and Recovery.**
4. Click **Diagnose hardware.**

For more information about PC-Doctor, see the Help for the program.

FRU tests

The following table shows the test for each FRU.

Table 1. FRU tests

FRU	Applicable test
System board	<ol style="list-style-type: none"> 1. Diagnostics --> CPU/Coprocessor 2. Diagnostics --> Systemboard
Power	Diagnostics --> ThinkPad Devices --> AC Adapter, Battery 1 (Battery2)
LCD unit	<ol style="list-style-type: none"> 1. Diagnostics --> Video Adapter 2. Interactive Tests --> Video
Audio	Enter the BIOS Setup Utility and change Serial ATA (SATA) setting to Compatibility , and run Diagnostics --> Other Device --> Conexant Audio
Speaker	<p>Interactive Tests --> Internal Speaker</p> <p>Note: Once Audio test is done, the no sound is heard this test. In this case, turn off and turn on the computer. Then, run this test again.</p>
Keyboard	<ol style="list-style-type: none"> 1. Diagnostics --> Systemboard --> Keyboard 2. Interactive Tests --> Keyboard
Hard disk drive or solid state drive	<p>Enter the BIOS Setup Utility and change Serial ATA (SATA) setting to Compatibility, and run Diagnostics --> Fixed Disks</p> <p>You can also diagnose the drive without starting up the operating system. To diagnose the drive from the BIOS Setup Utility, do as follows:</p> <ol style="list-style-type: none"> 1. Remove any diskette from the diskette drive, and then turn off the computer. 2. Turn on the computer. 3. While the message, "To interrupt normal startup, press Enter," is displayed at the lower left of the screen, press F1 to enter the BIOS Setup Utility. 4. Using cursor keys, select HDD diagnostic program. Press enter. 5. Using cursor keys, select Main hard disk drive. 6. Press Enter to start the diagnostic program.
Diskette drive	<ol style="list-style-type: none"> 1. Diagnostics --> Diskette Drives 2. Interactive Tests --> Diskette
Memory	<ol style="list-style-type: none"> 1. If two DIMMs are installed, remove one of them and run Diagnostics --> Advanced Memory Tests. 2. If the problem does not recur, return the DIMM to its place, remove the other one, and run the test again.
TrackPoint or pointing device	<p>If the TrackPoint does not work, check the configuration as specified in the BIOS Setup Utility. If the TrackPoint is disabled, select Automatic to enable it.</p> <p>After you use the TrackPoint, the pointer may drift on the screen for a short time. This drift can occur when a slight, steady pressure is applied to the TrackPoint pointer. This symptom is not a hardware problem. If the pointer stops after a short time, no service action is necessary.</p> <p>If enabling the TrackPoint does not correct the problem, continue with the following:</p> <ul style="list-style-type: none"> • Interactive Tests --> Mouse

Table 1. FRU tests (continued)

FRU	Applicable test
Touch Pad	If the Touch Pad does not work, check the configuration as specified in the BIOS Setup Utility. If the Touch Pad is disabled, select Automatic to enable it. If enabling the Touch Pad does not correct the problem, continue with the following: <ul style="list-style-type: none">• Interactive Tests --> Mouse

Power system checkout

To verify a symptom, do the following:

1. Turn off the computer.
2. Remove the battery pack.
3. Connect the AC adapter.
4. Check that power is supplied when you turn on the computer.
5. Turn off the computer.
6. Disconnect the AC adapter and install the charged battery pack.
7. Check that the battery pack supplies power when you turn on the computer.

If you suspect a power problem, see the appropriate one of the following power supply checkouts:

- "Checking the AC adapter"
- "Checking operational charging" on page 44
- "Checking the battery pack" on page 44
- "Checking the backup battery" on page 45

Checking the AC adapter

You are here because the computer fails only when the AC adapter is used.

- If the power problem occurs only when the docking station or the port replicator is used, replace the docking station or the port replicator.
- If the power-on indicator does not turn on, check the power cord of the AC adapter for correct continuity and installation.
- If the computer does not charge during operation, go to "Checking operational charging" on page 44.

To check the AC adapter, do the following:

1. Unplug the AC adapter cable from the computer.
2. Measure the output voltage at the plug of the AC adapter cable. See the following figure:

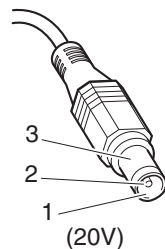

Pin	Voltage (V dc)
1	+20
2	0
3	Ground

Note: Output voltage of pin no.2 of the AC adapter may differ from the one you are servicing.

3. If the voltage is not correct, replace the AC adapter.
4. If the voltage is acceptable, do the following:
 - Replace the system board.
 - If the problem persists, go to "FRU tests" on page 41.

Note: Noise from the AC adapter does not always indicate a defect.

Checking operational charging

To check whether the battery charges properly during operation, use a discharged battery pack or a battery pack that has less than 50% of the total power remaining when installed in the computer.

Perform operational charging. If the battery status indicator or icon does not turn on, remove the battery pack and let it return to room temperature. Reinstall the battery pack. If the charge indicator or icon still does not turn on, replace the battery pack.

If the charge indicator still does not turn on, replace the system board. Then reinstall the battery pack. If it is still not charged, go to the next section.

Checking the battery pack

Battery charging does not start until the Power Manager Battery Gauge shows that less than 96% of the total power remains; under this condition the battery pack can charge to 100% of its capacity. This protects the battery pack from being overcharged or from having a shortened life.

To check your battery, move your cursor to the Power Manager Battery Gauge icon in the icon tray of the Windows taskbar and wait for a moment (but do not click), and the percentage of battery power remaining is displayed. To get detailed information about the battery, double-click the Power Manager Battery Gauge icon.

Note: If the battery pack becomes hot, it may not be able to charge. Remove it from the computer and leave it at room temperature for a while. After it cools down, reinstall and recharge it.

To check the battery pack, do the following:

1. Power off the computer.
2. Remove the battery pack and measure the voltage between battery terminals 1 (+) and 7 (-). See the following figure:

Note: ThinkVantage Toolbox through the "System Health" or through Diagnostics" features will proactively determine if the replacement of battery pack is required. A "POOR" condition indicates battery replacement is required for proper operation.

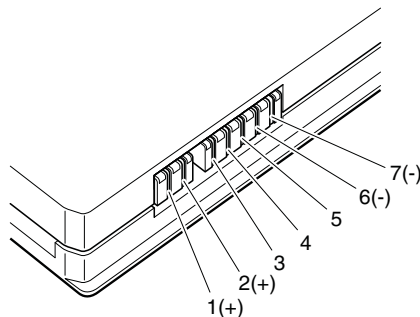

Terminal	Voltage (V dc)
1	+ 0 to + 12.6
7	Ground (-)

3. If the voltage is less than +11.0 V dc, the battery pack has been discharged.

Note: Recharging will take at least 3 hours, even if the indicator does not turn on.

If the voltage is still less than +11.0 V dc after recharging, replace the battery.

4. If the voltage is more than +11.0 V dc, measure the resistance between battery terminals 5 and 7. The resistance must be 4 to 30 K Ω .

If the resistance is not correct, replace the battery pack. If the resistance is correct, replace the system board.

Checking the backup battery

Do the following:

1. Power off the computer, and unplug the AC adapter from it.
2. Turn the computer upside down.
3. Remove the battery pack (see "1010 Battery pack" on page 68).
4. Remove the backup battery (see "1090 Backup battery" on page 86).
5. Measure the voltage of the backup battery. See the following figure.

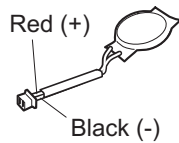

Wire	Voltage (V dc)
Red	+2.5 to +3.2
Black	Ground

- If the voltage is correct, replace the system board.
- If the voltage is not correct, replace the backup battery.
- If the backup battery discharges quickly after replacement, replace the system board.

Related service information

This chapter presents following information:

- “Restoring the factory contents by using Recovery Disc Set”
- “Passwords” on page 48
- “Power management” on page 52
- “Symptom-to-FRU index” on page 53

Service Web site:

When the latest maintenance diskette and the system program service diskette become available, they will be posted on <http://www.lenovo.com/spm>

Restoring the factory contents by using Recovery Disc Set

When the hard disk drive (HDD) or solid state drive (SSD) is replaced because of a failure, no product recovery program is on the new drive. In this case, you must use the Recovery Disc Set for the computer. Order the Recovery Disc Set and the drive at the same time so that you can recover the new drive with the pre-installed software when they arrive. For information on which discs to order, see “Recovery discs” on page 132.

The recovery disc set consists of the user instructions and the following set of DVDs to restore the computer to the original factory configuration.

Operating System Recovery Disc (one disc)

This disc restores the Microsoft® Windows operating system. Use this disc to start the recovery process.

Applications and Drivers Recovery Disc (one or more discs)

This disc restores the preinstalled applications and drivers on the computer.

Supplemental Recovery Disc

This disc contains additional content, such as updates to the software that was preinstalled on the computer. Not all recovery disc sets come with a *Supplemental Recovery Disc*.

Notes:

- You must have a DVD drive to use the recovery discs. If you do not have an internal DVD drive, you can use an external USB DVD drive.
- During the recovery process, all data on the drive will be deleted. If possible, copy any important data or personal files that you want to keep onto removable media or a network drive before you start the recovery process.

To restore the computer to the original factory configuration using the recovery disc set, do the following:

Note: Recovery takes several hours. The length of time depends on the method you use. If you use recovery discs, recovery takes at least five hours.

1. Make the CD/DVD drive the first startup device in the startup sequence using the following procedure:
 - a. Press and hold down the F1 key, and then turn on the computer. When the logo screen is displayed or if you hear repeating beeps, release the F1 key. The Setup Utility program opens.
 - b. Use the arrow keys to select **Startup** → **Boot**.
 - c. Select the CD/DVD drive as the **1st Boot Device**.
2. Insert the *Operating System Recovery Disc* into the DVD drive.
3. Press F10 to save the Setup Utility configuration changes. Follow the instructions on the screen to begin the recovery process.
4. Select your language and click **Next**.
5. Read the license. If you agree with the terms and conditions, select **I accept these terms and conditions** and then click **Next**. If you do not agree with the terms and conditions, follow the instructions on the screen.
6. Click **Yes** in the displayed window to begin the operating system recovery process.
7. Insert the *Applications and Drivers Recovery Disc* when prompted and then click **OK** to begin the applications and drivers recovery process.
8. If you have a *Supplemental Recovery Disc*, insert it when prompted and click **Yes**. If you do not have a *Supplemental Recovery Disc*, click **No**.
9. When all of the data has been copied from the last disc in the set and has been processed, remove the disc and restart the computer.

Note: The rest of the recovery process is fully automated and no action is required by you. The computer will restart into the Microsoft Windows desktop several times and you might experience periods when no activity is apparent on the screen for several minutes at a time. This is normal.

10. When the recovery process is complete, the Set Up Windows screen is displayed. Follow the instructions on the screen to complete the Windows setup.
11. After you have completed the Windows setup, you might want to restore the original startup sequence. Start the Setup Utility program and then press F9 to restore the default settings. Press F10 to save and exit the Setup Utility.

Note: After restoring a drive to the factory default settings, you might need to reinstall some device drivers.

Passwords

As many as three passwords may be needed for any ThinkPad Notebook: the power-on password (POP), the hard-disk password (HDP), and the supervisor password (SVP).

If any of these passwords has been set, a prompt for it appears on the screen whenever the computer is turned on. The computer does not start until the password is entered.

Exception: If only an SVP is installed, the password prompt does not appear when the operating system is booted.

Power-on password

A power-on password (POP) protects the system from being powered on by an unauthorized person. The password must be entered before an operating system can be booted. For how to remove the POP, see “How to remove the power-on password.”

Hard-disk password

There are two hard-disk passwords (HDPs):

- User HDP—for the user
- Master HDP—for the system administrator, who can use it to get access to the hard disk even if the user has changed the user HDP

Note: There are two modes for the HDP: **User only** and **Master + User**. The **Master + User** mode requires two HDPs; the system administrator enters both in the same operation. The system administrator then provides the user HDP to the system user.

Attention: If the user HDP has been forgotten, check whether a master HDP has been set. If it has, it can be used for access to the hard disk drive. If no master HDP is available, neither Lenovo nor Lenovo authorized service technicians provide any services to reset either the user or the master HDP, or to recover data from the hard disk drive. The hard disk drive can be replaced for a scheduled fee.

For how to remove the POP, see “How to remove the hard-disk password” on page 50.

Supervisor password

A supervisor password (SVP) protects the system information stored in the BIOS Setup Utility. The user must enter the SVP in order to get access to the BIOS Setup Utility and change the system configuration.

Attention: If the SVP has been forgotten and cannot be made available to the service technician, there is no service procedure to reset the password. The system board must be replaced for a scheduled fee.

How to remove the power-on password

To remove a POP that you have forgotten, do the following:

(A) *If no SVP has been set:*

1. Turn off the computer.
2. Remove the battery pack.
For how to remove the battery pack, see “1010 Battery pack” on page 68.
3. Remove the backup battery.
For how to remove the backup battery, see “1090 Backup battery” on page 86.
4. Turn on the computer and wait until the POST ends.

After the POST ends, the password prompt does not appear. The POP has been removed.

5. Reinstall the backup battery and the battery pack.

(B) *If an SVP has been set and is known by the service technician:*

1. Turn on the computer.
2. When the ThinkPad logo comes up, immediately press F1 to enter BIOS Setup Utility.

For models supporting the Passphrase function, press F1 while the POP icon is appearing on the screen; then enter the POP. For the other models, enter the POP.

Note: To check whether the ThinkPad Notebook you are servicing supports the Passphrase function, enter the BIOS Setup Utility and go to **Security --> Password**. If the **Using Passphrase** item is displayed in the menu, this function is available on the ThinkPad Notebook.

3. Select **Security**, using the cursor directional keys to move down the menu.
4. Select **Password**.
5. Select **Power-On Password**.
6. Type the current SVP in the **Enter Current Password** field. then leave the **Enter New Password** field blank, and press Enter twice.
7. In the Changes have been saved window, press Enter.
8. Press F10; then, in the Setup confirmation window, select **Yes**.

How to remove the hard-disk password

Attention: If **User only** mode is selected and the user HDP has been forgotten and cannot be made available to the service technician, neither Lenovo nor Lenovo authorized service technicians provide any services to reset the user HDPs or to recover data from the hard disk drive. The hard disk drive can be replaced for a scheduled fee.

To remove a user HDP that has been forgotten, when the SVP and the master HDP are known, do the following:

1. Turn on the computer.
2. When the ThinkPad logo comes up, immediately press F1 to enter BIOS Setup Utility.

For models supporting the Passphrase function, press F1 while HDP icon is appearing on the screen; then enter the master HDP. For the other models, enter the master HDP.

Note: To check whether the ThinkPad Notebook you are servicing supports the Passphrase function, enter the BIOS Setup Utility and go to **Security --> Password**. If **Using Passphrase** item is displayed in the menu, this function is available on the ThinkPad Notebook.

3. Select **Security**, using the cursor directional keys to move down the menu.
4. Select **Password**.
5. Select **Hard-disk x password**, where *x* is the letter of the hard disk drive. A pop-up window opens.
6. Select **Master HDP**.

7. Type the current master HDP in the **Enter Current Password** field. then leave the **Enter New Password** field blank, and press Enter twice.
8. Press F10.
9. Select **Yes** in the Setup Configuration window.
Both user HDP and master HDP will have been removed.

Power management

To reduce power consumption, the computer has three power management modes: screen blank, sleep, and hibernation.

Screen blank mode

To put the computer into screen blank mode, do as follows:

1. Right-click the Power Manager Battery Gauge in the task bar.
2. Select **Power off display**.

Sleep mode

When the computer enters sleep mode, the following events occur in addition to what occurs in screen blank mode:

- The LCD is powered off.
- The hard disk drive is powered off.
- The CPU stops.

To enter sleep mode, do as follows:

1. Click **Start**.
2. Click the triangle mark on the right side of the **Shut down** icon; then select **Sleep**.

To return from sleep mode, press the Fn key.

Hibernation mode

By using this mode, you can turn off your computer completely without saving files or exiting from any applications that are running. When you enter hibernation, all open applications, folders, and files are saved to the hard disk, and then the computer turns off.

To enter hibernation mode, do as follows:

1. Click **Start**.
2. Click the triangle mark on the right side of the **Shut down** icon; then select **Hibernate**.

To return from hibernation mode, press the power button for more than 4 seconds.

Symptom-to-FRU index

This section contains following information:

- “Numeric error codes”
- “Error messages” on page 56
- “No-beep symptoms” on page 56
- “LCD-related symptoms” on page 57
- “Intermittent problems” on page 58
- “Undetermined problems” on page 58

The symptom-to-FRU index in this section lists symptoms and errors and their possible causes. The most likely cause is listed first, in boldface type.

Note: Do the FRU replacement or other actions in the sequence shown in the column headed “FRU or action, in sequence.” If replacing a FRU does not solve the problem, put the original part back in the computer. Do not replace a nondefective FRU.

This index can also help you determine, during regular servicing, what FRUs are likely to need to be replaced next.

A numeric error is displayed for each error detected in POST or system operation. In the displays, **n** can be any number.

If no numeric code is displayed, check the narrative descriptions of symptoms. If the symptom is not described there, go to “Intermittent problems” on page 58.

Note:

For a device not supported by diagnostic codes in the ThinkPad Notebooks, see the manual for that device.

Numeric error codes

Table 2. Numeric error codes

Symptom or error (beeps, if any)	FRU or action, in sequence
0187 EAIA data access error—The access to EEPROM is failed. (two short beeps)	System board.
0189 Invalid RFID configuration information area—The EEPROM checksum is not correct. (two short beeps)	System board.
0190 Critical low-battery error (two short beeps)	1. Charge the battery pack. 2. Battery pack.
0191 System Security—Invalid Remote Change requested.	1. Run BIOS Setup Utility, and then save current setting by pressing F10. 2. System board.
0210 Stuck Key (two short beeps)	Change keyboard, and restart the computer.

Table 2. Numeric error codes (continued)

Symptom or error (beeps, if any)	FRU or action, in sequence
0211 Keyboard error (two short beeps)	Run interactive tests of the keyboard and the auxiliary input device.
0230 Shadow RAM error—Shadow RAM fails at offset nnnn. (two short beeps)	System board.
0231 System RAM error—System RAM fails at offset nnnn. (two short beeps)	1. DIMM. 2. System board.
0232 Extended RAM error— Extended RAM fails at offset nnnn. (two short beeps)	1. DIMM. 2. System board.
0250 System battery error—System battery is dead. (two short beeps)	1. Charge the backup battery for more than 8 hours by connecting the ac adapter. 2. Replace the backup battery and run BIOS Setup Utility to reset the time and date.
0251 System CMOS checksum bad— Default configuration used. (two short beeps)	1. Charge the backup battery for more than 8 hours by connecting the ac adapter. 2. Replace the backup battery and run BIOS Setup Utility to reset the time and date.
0254 System NV7 Volume checksum bad- Default configuration used (two short beeps)	Turn off the computer and discharge CMOS. Then restart the computer.
0260 System timer error. (two short beeps)	1. Charge the backup battery for more than 8 hours by connecting the ac adapter. 2. Replace the backup battery and run BIOS Setup Utility to reset the time and date. 3. System board.
0270 Real-time clock error. (two short beeps)	1. Charge the backup battery for more than 8 hours by connecting the ac adapter. 2. Replace the backup battery and run BIOS Setup Utility to reset the time and date. 3. System board.
0271 Date and time error—Neither the date nor the time is set in the computer. (two short beeps)	Run BIOS Setup Utility to reset the time and date.
0280 Previous boot incomplete— Default configuration used. (two short beeps)	1. Load “Setup Default” in BIOS Setup Utility. 2. DIMM. 3. System board.
02D0 System cache error. (two short beeps)	1. CPU. 2. System board.

Table 2. Numeric error codes (continued)

Symptom or error (beeps, if any)	FRU or action, in sequence
02F0 CPU ID:xx Failed.	1. CPU. 2. System board.
02F5 DMA test failed. (two short beeps)	1. DIMM. 2. System board.
02F6 Software NMI failed (two short beeps)	1. DIMM. 2. System board.
02F7 Fail-safe timer NMI failed (two short beeps)	1. DIMM. 2. System board.
1802 Unauthorized network card is plugged in—Turn off and remove the miniPCI network card. (two short beeps)	1. Remove the Mini PCI network card. 2. System board.
1804 Unauthorized WAN card is plugged in—Power off and remove the WAN card.	1. Remove the wireless WAN card. 2. System board.

Error messages

Table 3. Error messages

Symptom or error (beeps, if any)	FRU or action, in sequence
Bad CRC2. Enter BIOS Setup Utility, and load Setup defaults. (two short beeps)	Press F1 to enter BIOS Setup Utility. Press F9 , and Enter to load the default setting. Then save the current setting by pressing F10 , and restart the computer.
Fan error. (four short beeps, one long beep)	<ol style="list-style-type: none"> 1. Fan. 2. Thermal grease. 3. System board.
DRAM is unplugged. (one short beep, pause, three short beeps, pause, three short beeps, pause, one short beep.)	Memory card is not installed. Install memory card.
DRAM is not well plugged. (one short beep, pause, three short beeps, pause, three short beeps, pause, one short beep.)	Reinstall the memory card.
Operating system not found.	<ol style="list-style-type: none"> 1. Check that the operating system has no failure and is installed correctly. 2. Enter BIOS Setup Utility and see whether the hard disk drive is properly identified. If you still see the same error message, check the boot sequence. 3. Reinstall the hard disk drive. 4. Reinstall the operating system.
System Configuration Data Read Error (two short beeps)	Press F1 to enter BIOS Setup Utility. Press F9 , and Enter to load the default setting. Then save the current setting by pressing F10 , and restart the computer.

No-beep symptoms

Table 4. No-beep symptoms

Symptom or error	FRU or action, in sequence
No beep, power-on indicator on, LCD blank, and no POST.	<ol style="list-style-type: none"> 1. Make sure that every connector is connected tightly and correctly. 2. DIMM. 3. System board.
No beep, power-on indicator on, and LCD blank during POST.	<ol style="list-style-type: none"> 1. Reseat DIMM. 2. System board.
The power-on password prompt appears.	A power-on password or a supervisor password is set. Type the password and press Enter .
The hard-disk password prompt appears.	A hard-disk password is set. Type the password and press Enter .

LCD-related symptoms

Important: The TFT LCD for the notebook computer contains many thin-film transistors (TFTs). The presence of a small number of dots that are missing, discolored, or always lighted is characteristic of TFT LCD technology, but excessive pixel problems can cause viewing concerns.

If the LCD you are servicing has two or less visible defective pixels, it should not be considered faulty. However, if the LCD has three or more visible defective pixels, it will be deemed as defective by Lenovo and it should be replaced.

Notes:

- This policy applies to all ThinkPad Notebooks purchased on 1 January, 2008 or later.
- Lenovo will not provide replacement if the LCD is within specification as we cannot guarantee that any replacement LCD will have zero pixel defects.
- One pixel consists of R, G, B sub-pixels.

Table 5. LCD-related symptoms

Symptom or error	FRU or action, in sequence
No beep, power-on indicator on, and a blank LCD during POST.	System board.
<ul style="list-style-type: none"> • LCD backlight not working. • LCD too dark. • LCD brightness cannot be adjusted. • LCD contrast cannot be adjusted. 	<ol style="list-style-type: none"> 1. Reseat the LCD connectors. 2. LCD assembly. 3. System board.
<ul style="list-style-type: none"> • LCD screen unreadable. • Characters missing pixels. • Screen abnormal. • Wrong color displayed. 	<ol style="list-style-type: none"> 1. See important note for “LCD-related symptoms.” 2. Reseat all LCD connectors. 3. LCD assembly. 4. System board.
Horizontal or vertical lines displayed on LCD.	LCD assembly.

Intermittent problems

Intermittent system hang problems can be due to a variety of causes that have nothing to do with a hardware defect, such as cosmic radiation, electrostatic discharge, or software errors. FRU replacement should be considered only when a problem recurs.

When analyzing an intermittent problem, do the following:

1. Run the diagnostic test for the system board in loop mode **at least 10 times**.
2. If no error is detected, do **not** replace any FRUs.
3. If any error is detected, replace the FRU shown by the FRU code. Rerun the test to verify that no more errors exist.

Undetermined problems

If the diagnostic tests did not identify the adapter or device that has failed, if wrong devices are installed, or if the system simply is not operating, follow these procedures to isolate the failing FRU (do not isolate FRUs that have no defects).

Verify that all attached devices are supported by the computer.

Verify that the power supply being used at the time of the failure is operating correctly. (See "Power system checkout" on page 43.)

1. Turn off the computer.
2. Visually check each FRU for damage. Replace any damaged FRU.
3. Remove or disconnect all of the following devices:
 - a. Non-ThinkPad devices
 - b. Devices attached to the docking station or the port replicator
 - c. Printer, mouse, and other external devices
 - d. Battery pack
 - e. Hard disk drive
 - f. External diskette drive or optical drive
 - g. DIMM
 - h. Optical disk or diskette in the internal drive
 - i. PC Cards
4. Turn on the computer.
5. Determine whether the problem has been solved.
6. If the problem does not recur, reconnect the removed devices one at a time until you find the failing FRU.
7. If the problem remains, replace the following FRUs one at a time (do not replace a nondefective FRU):
 - a. System board
 - b. LCD assembly

Status indicators

This chapter presents the system status indicators that show the status of the computer.

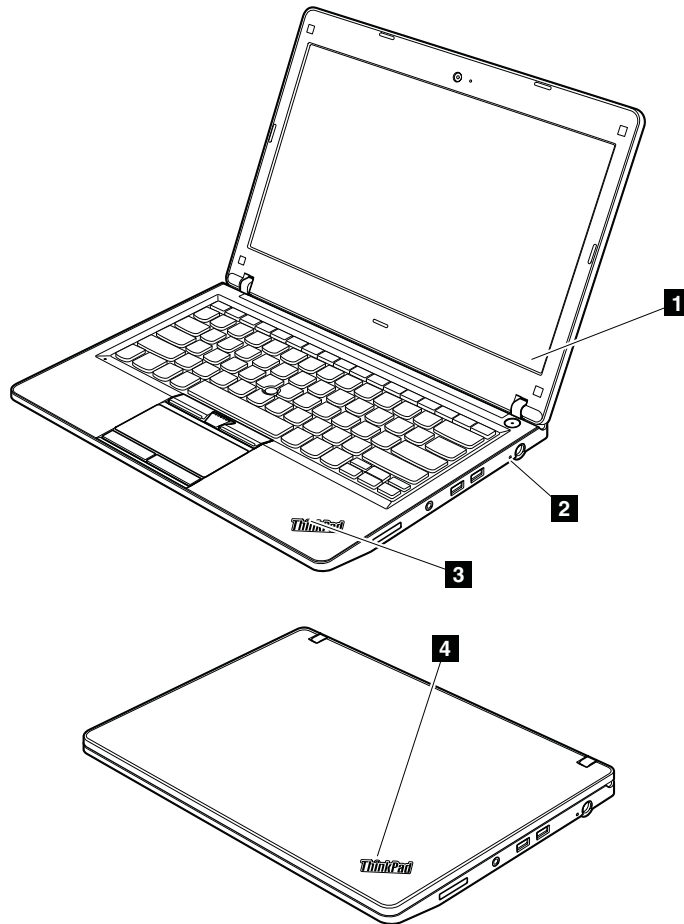

Table 6. Status indicators



Indicator	Meaning
1 On-screen indicators	<p>Caps lock:</p>  <p>Caps Lock mode is enabled. You can enter all alphabetic characters (A-Z) in uppercase without pressing the Shift key.</p> <p>Wireless status:</p> <p>Press F9 to enable or disable the wireless features. You can quickly change the power state of each feature in the list.</p>
2 Power status	<p>Green: The AC adapter is connected. If a battery is installed on the computer, it is charged when this indicator is on.</p> <p>Off: The AC adapter is not connected.</p>

Table 6. Status indicators (continued)

Indicator	Meaning
<p>3 Sleep (standby) status</p> 	<p>The illumination dot in the ThinkPad logo on the outer lid of the computer and on the palm rest works as a system-status indicator: it shows whether the computer is in sleep (standby), hibernation, or normal model.</p> <p>Red: The computer is on (in normal mode).</p> <p>Fast blinking red:</p>
<p>4 Sleep (standby) status</p> 	<p>The computer is entering sleep (standby) or hibernation mode.</p> <p>Slow blinking red: The computer is in sleep (standby) mode.</p> <p>Off: The computer is off or in hibernation mode.</p>

Special keys

This computer has several special keys at the upper row of the keyboard. To use each function, directly press the desired key.

Note: To use F1 - F12 functions, press Fn and the desired function key simultaneously; this is the default setting.

The following table shows the function of each special key.

Table 7. Fn key combinations













Special key	Description
Speaker mute (F1) 	If you mute the sound and then turn off the computer, the sound will remain muted when you turn on the computer again. To turn on the sound, press the Speaker volume up or Speaker volume down keys.
Speaker volume down (F2) 	
Speaker volume up (F3) 	
Microphone mute (F4) 	When you press the microphone mute key, all of the recording devices are set on mute or unmute; this is the default setting.
Camera mute (F5) 	During a video conference, you can control the video streaming from the integrated camera by pressing this key. The video output will be grayed out, and the audio streaming will continue.
Switching a display output location (F6) 	<p>For Windows 7: Switch between the computer display and an external monitor. Windows will show these display options:</p> <ul style="list-style-type: none"> • Computer display only (LCD) • Computer display and external monitor (same image) • Computer display and external monitor (extended desktop function) • External monitor only <p>Note: To switch between the computer display and an external monitor, the Win+P key combination is also available.</p>
Display brightness down (F7) 	<p>The computer display becomes dimmer.</p> <p>The purpose of this method is to change the brightness level temporarily. To change the default brightness level, change the settings of the Power Option in the Control Panel or use the Power Manager.</p>
Display brightness up (F8) 	<p>The computer display becomes brighter.</p> <p>The purpose of this method is to change the brightness level temporarily. To change the default brightness level, change the settings of the Power Option in the Control Panel or use the Power Manager.</p>

Table 7. Fn key combinations (continued)

Special key	Description
Wireless radio control (F9) 	Enable or disable the built-in wireless networking features. If you press this key, a list of wireless features is displayed. You can quickly change the power state of each feature in the list. Note: To use this function, following device drivers must be installed on the computer beforehand: <ul style="list-style-type: none"> • Power Management driver • OnScreen Display Utility • Wireless device drivers
Previous track/scene (F10) 	For Multimedia control.
Play/pause (F11) 	
Next track/scene (F12) 	

FRU replacement notices

This chapter presents notices related to removing and replacing parts. Read this chapter carefully before replacing any FRU.

Screw notices

Loose screws can cause a reliability problem. In the ThinkPad Notebook, this problem is addressed with special nylon-coated screws that have the following characteristics:

- They maintain tight connections.
- They do not easily come loose, even with shock or vibration.
- They are harder to tighten.
- Each one should be used only once.

Do the following when you service this machine:

- Keep the screw kit (for the P/N, see “Miscellaneous parts” on page 130) in your tool bag.
- Always use new screws.
- Use a torque screwdriver if you have one.

Tighten screws as follows:

- **Plastic to plastic**

Turn an additional **90 degrees** after the screw head touches the surface of the plastic part:

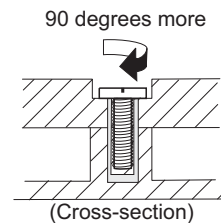

- **Logic card to plastic**

Turn an additional **180 degrees** after the screw head touches the surface of the logic card:

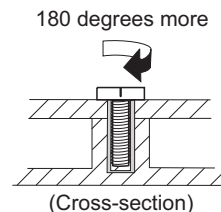

- **Torque driver**

If you have a torque driver, refer to the “Torque” column for each step.

- Make sure that you use the correct screw. If you have a torque screwdriver, tighten all screws firmly to the torque shown in the table. **Never use a screw that you removed. Use a new one. Make sure that all of the screws are tightened firmly.**
- Ensure torque screw drivers are calibrated correctly following country specifications.

Retaining serial numbers

This section includes the following descriptions:

- “Restoring the serial number of the system unit”
- “Retaining the UUID”
- “Reading or writing the ECA information” on page 65

Restoring the serial number of the system unit

When the computer was manufactured, the EEPROM on the system board was loaded with the serial numbers of the system and all major components. These numbers need to remain the same throughout the life of the computer.

If you replace the system board, you must restore the serial number of the system unit to its original value.

Before replacing the system board, save the original serial number by doing the following:

1. Install the LENOVO ThinkPad Hardware Maintenance Diskette Version 1.76 or later, and restart the computer.
2. From the main menu, select **1. Set System Identification**.
3. Select **2. Read S/N data from EEPROM**.

The serial number of each device in your computer is displayed; the serial number of the system unit is listed as follows:

- 20: Serial number

Write down that number.

Note: The serial number of the system unit is also written on the label attached to the bottom of the computer.

After you have replaced the system board, restore the serial number by doing the following:

1. Install the LENOVO ThinkPad Hardware Maintenance Diskette Version 1.76 or later and restart the computer.
2. From the main menu, select **1. Set System Identification**.
3. Select **1. Add S/N data from EEPROM**.
Follow the instructions on the screen.

If the MTM and Product ID numbers differ from each other on the rear label, use what is shown for the Product ID field. See example below:

MTM on rear label:

TTTT-CTO S/N SSSSSS

Product ID on rear label:

TTTT-MMM (Use this number when setting Serial Number)

In the example, the Serial Number to be input is '1STTTTMMMSSSSSS'.

Retaining the UUID

The Universally Unique Identifier (UUID) is a 128-bit number uniquely assigned to your computer at production and stored in the EEPROM of your system board.

The algorithm that generates the number is designed to provide unique IDs until the year A.D. 3400. No two computers in the world have the same number.

When you replace the system board, you must set the UUID on the new system board as follows:

1. Install the LENOVO ThinkPad Hardware Maintenance Diskette Version 1.76 or later, and restart the computer.
2. From the main menu, select **4. Assign UUID.**

A new UUID is created and written. If a valid UUID already exists, it is not overwritten.

Reading or writing the ECA information

Information on Engineering Change Announcements (ECA) are stored in the EEPROM of the system board. The electronic storage of this information simplifies the procedure to check if the ECA has been previously applied to a machine. The machine does not need to be disassembled to check for the ECA application.

To check what ECAs have been previously applied to the machine, use the ECA Information Read/Write function on the LENOVO ThinkPad Hardware Maintenance Diskette Version 1.76 or later.

1. Insert the LENOVO ThinkPad Hardware Maintenance Diskette Version 1.76 or later, and restart the computer.
2. From the main menu, select **6. Set ECA Information.**
3. To read ECA information, select **2. Read ECA/rework number from EEPROM** and follow the instruction.
4. To read box build date, select **5. Read box build date from EEPROM**, and follow the instruction on the screen.

After an ECA has been applied to the machine, the EEPROM must be updated to reflect the ECA's application. Use the LENOVO ThinkPad Hardware Maintenance Diskette Version 1.76 or later to update the EEPROM.

Note: Only the ECA number is stored in the EEPROM. The machine type of the ECA is assumed be the same as the machine type of the machine that had the ECA applied to it.

1. Insert the LENOVO ThinkPad Hardware Maintenance Diskette Version 1.76 or later, and restart the computer.
2. From the main menu, select **6. Set ECA Information.**
3. To write ECA information, select **1. Write ECA/rework number from EEPROM**, and follow the instruction.
4. To write box build date, select **4. Write box build date from EEPROM**, and follow the instruction on the screen.

If the system board is being replaced, try to read the ECA information from the old system board and transfer the information to the new system. If the system board is inoperable, this will not be possible.

Removing and replacing a FRU

This chapter presents directions and drawings for use in removing and replacing a FRU. Be sure to observe the following general rules:

1. Do not try to service any computer unless you have been trained and certified. An untrained person runs the risk of damaging parts.
2. Before replacing any FRU, review “FRU replacement notices” on page 63.
3. Begin by removing any FRUs that have to be removed before the failing FRU. Any such FRUs are listed at the top of the page. Remove them in the order in which they are listed.
4. Follow the correct sequence in the steps for removing the FRU, as given in the drawings by the numbers in square callouts.
5. When turning a screw to replace a FRU, turn it in the direction as given by the arrow in the drawing.
6. When removing the FRU, move it in the direction as given by the arrow in the drawing.
7. To put the new FRU in place, reverse the removal procedure and follow any notes that pertain to replacement. For information about connecting and arranging internal cables, see “Locations” on page 115.
8. When replacing a FRU, use the correct screw as shown in the procedures.



DANGER

Before removing any FRU, turn off the computer, unplug all power cords from electrical outlets, remove the battery pack, and then disconnect any interconnecting cables.

Attention: After replacing a FRU, do not turn on the computer until you have made sure that all screws, springs, and other small parts are in place and none are loose inside the computer. Verify this by shaking the computer gently and listening for rattling sounds. Metallic parts or metal flakes can cause electrical short circuits.

Attention: The system board is sensitive to, and can be damaged by, electrostatic discharge. Before touching it, establish personal grounding by touching a ground point with one hand or by using an electrostatic discharge (ESD) strap (P/N 6405959).

1010 Battery pack

Important notice for replacing a battery pack:

ThinkVantage Toolbox has an automatic battery diagnostic that determines if the battery pack is defective. A battery pack FRU should not be replaced unless this diagnostic shows that the battery is defective.

The only exception to this is if the battery pack is physically damaged or a customer is reporting a possible safety issue.

If ThinkVantage Toolbox is not installed in the computer, the customer should download this program before a non-physically damaged battery pack is replaced. Note that a physically damaged battery pack is non-warranty replacement.

Table 8. Removal steps of battery pack



DANGER

Use only the battery specified in the parts list for your computer. Any other battery could ignite or explode.

Table 8. Removal steps of battery pack (continued)

Unlock the battery latch **1**. Holding the battery latch in the unlocked position **2**, remove the battery pack in the direction shown by arrow **3**.

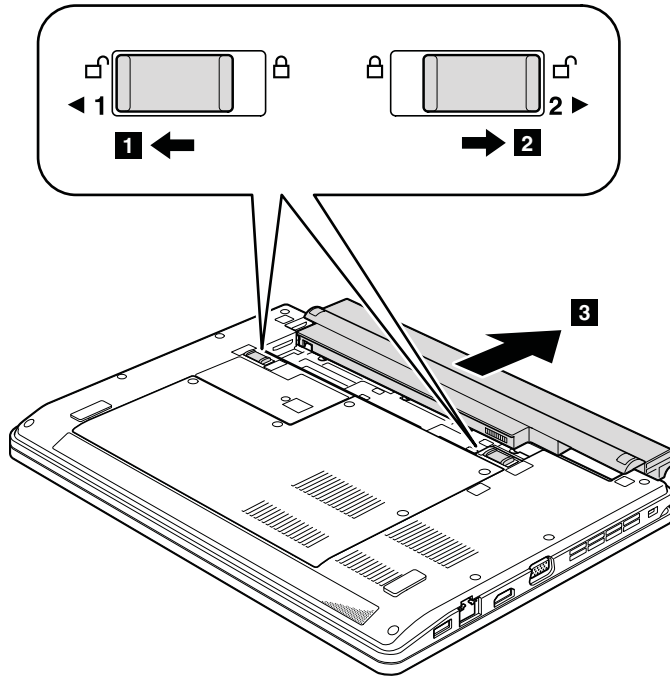

When installing: Install the battery pack in the slot, and then make sure that the battery latch is in the locked position.

1020 Bottom slot cover

For access, remove this FRU:

- "1010 Battery pack" on page 68

Table 9. Removal steps of bottom slot cover

Note: Loosen the screws **1**, but do not remove them.

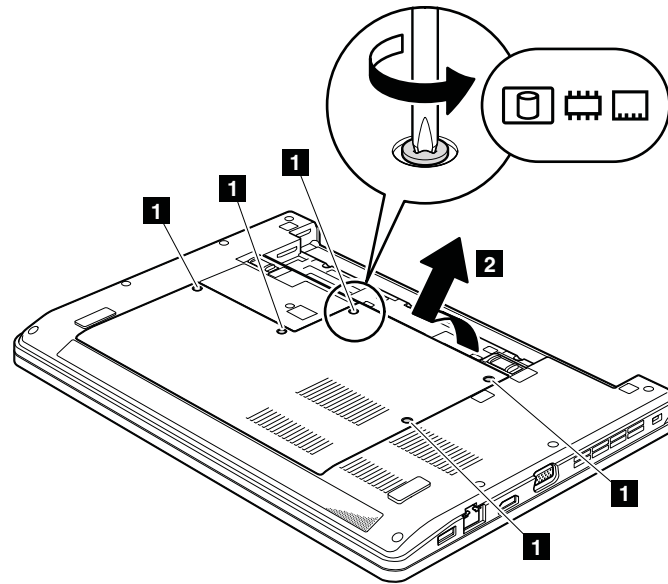

When installing: Make sure that all the projections of the cover are attached firmly to the frame. Then secure the screws.

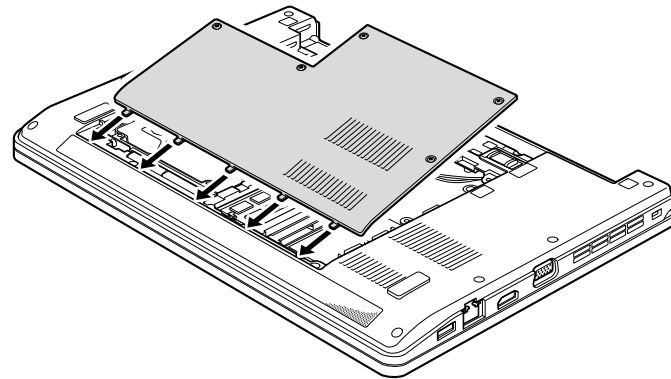

Note: Applying label to the bottom slot cover

When you replace the cover, following label needs to be peeled off from the old cover, and needs to be put on the new cover:

- 1** Asset tag label

For the label location, refer the following figure:

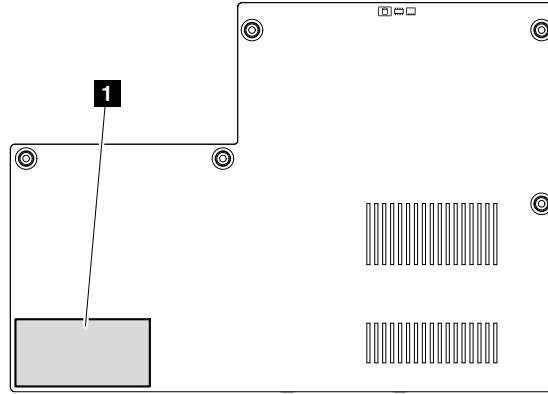

1030 DIMM

For access, remove these FRUs in order:

- “1010 Battery pack” on page 68
- “1020 Bottom slot cover” on page 70

Table 10. Removal steps of DIMM

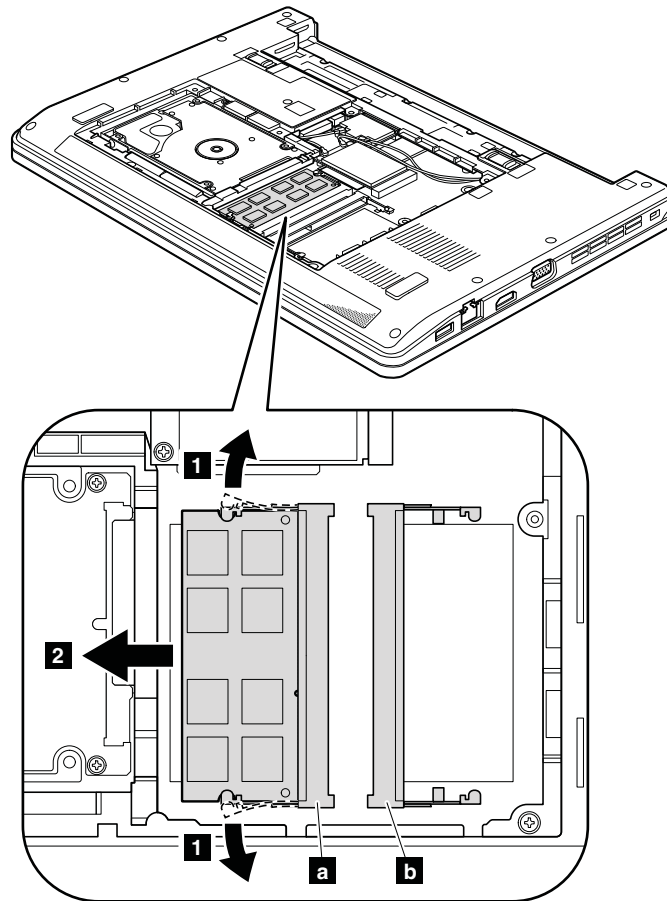

Note: If only one DIMM is used on the computer you are servicing, the card must be installed in SLOT-0 (**a**), but not in SLOT-1 (**b**).

When installing: Insert the notched end of the DIMM into the socket. Press the DIMM firmly, and pivot it until it snaps into the place. Make sure that it is firmly fixed in the slot and does not move easily.

1040 Hard disk drive (HDD)

For access, remove these FRUs in order:

- “1010 Battery pack” on page 68
- “1020 Bottom slot cover” on page 70

Attention:

- **Do not drop the drive or apply any physical shock to it.** The drive is sensitive to physical shock. Improper handling can cause damage and permanent loss of data.
- Before removing the drive, have the user make a backup copy of all the information on it if possible.
- Never remove the drive while the system is operating or is in suspend mode.

Table 11. Removal steps of HDD

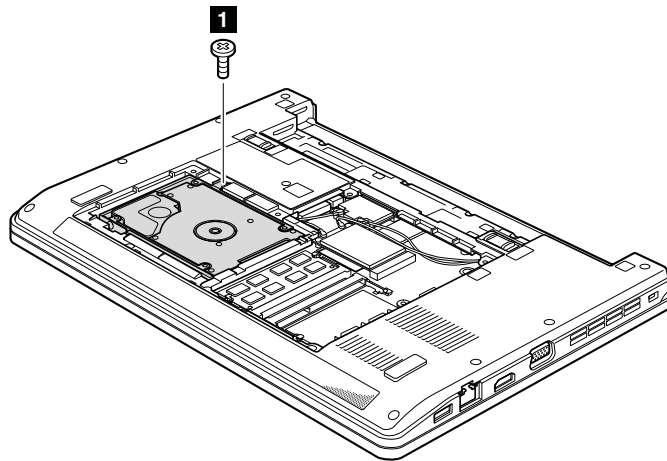

Step	Screw (quantity)	Color	Torque
1	M2 × 3 mm, wafer-head, nylon-coated (1)	Black	0.181 Nm (1.85 kgfcm)

Table 11. Removal steps of HDD (continued)

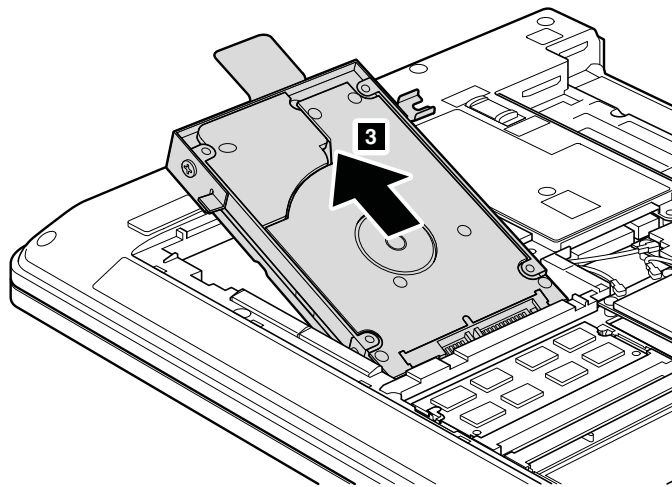
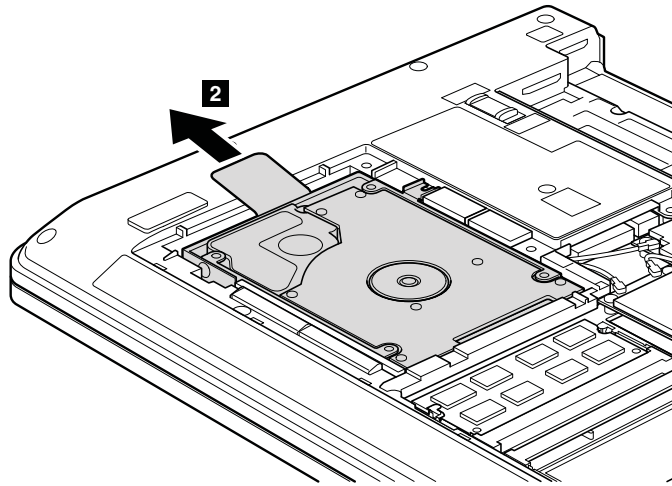

When installing: Make sure that the HDD connector is attached firmly.

1050 PCI Express Mini Card for wireless LAN

For access, remove these FRUs in order:

- “1010 Battery pack” on page 68
- “1020 Bottom slot cover” on page 70

Table 12. Removal steps of PCI Express Mini Card for wireless LAN

In step **1**, unplug the jacks by using the removal tool antenna RF connector (P/N: 08K7159) or pick the connectors with your fingers and gently unplug them in direction of the arrow.

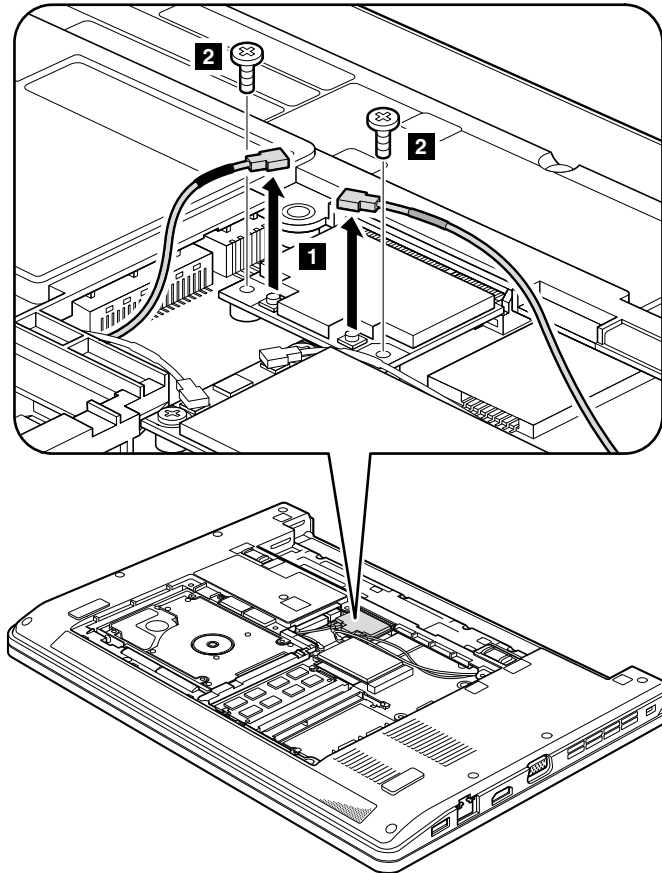

Step	Screw (quantity)	Color	Torque
2	M2 × 3 mm, wafer-head, nylon-coated (2)	Black	0.181 Nm (1.85 kgfcm)

Table 12. Removal steps of PCI Express Mini Card for wireless LAN (continued)

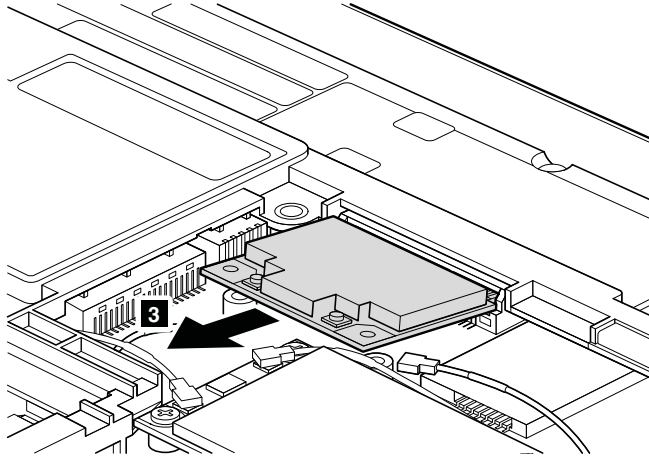

When installing: Plug the gray cable into the jack marked **MAIN** or **M**, and the black cable into the jack marked **AUX** or **A** on the card.

1060 PCI Express Mini Card for wireless WAN

For access, remove these FRUs in order:

- “1010 Battery pack” on page 68
- “1020 Bottom slot cover” on page 70

Table 13. Removal steps of PCI Express Mini Card for wireless WAN

In step **1**, unplug the jacks by using the removal tool antenna RF connector (P/N: 08K7159) or pick the connectors with your fingers and gently unplug them in direction of the arrow.

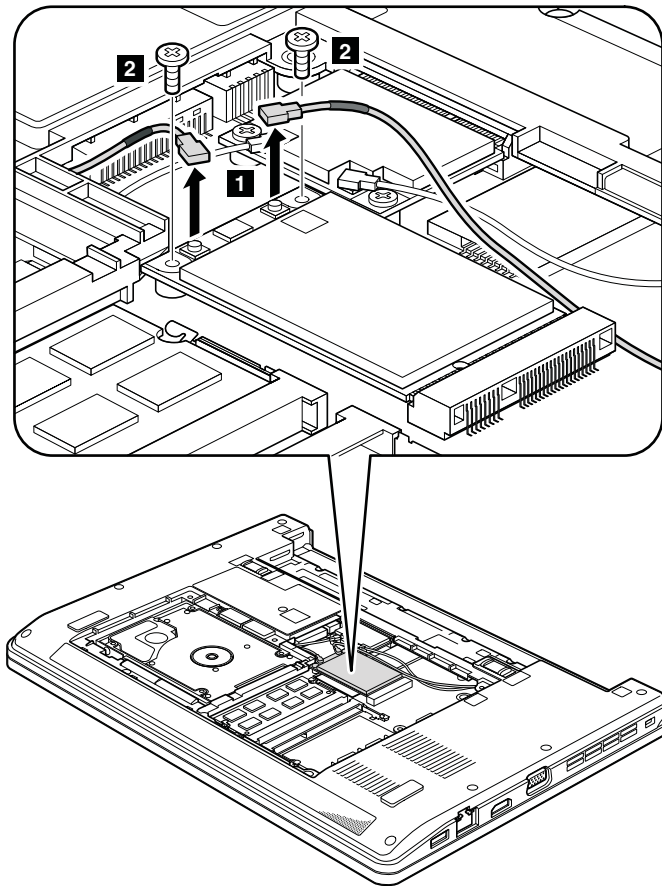

Step	Screw (quantity)	Color	Torque
2	M2 × 3 mm, wafer-head, nylon-coated (2)	Black	0.181 Nm (1.85 kgfcm)

Table 13. Removal steps of PCI Express Mini Card for wireless WAN (continued)

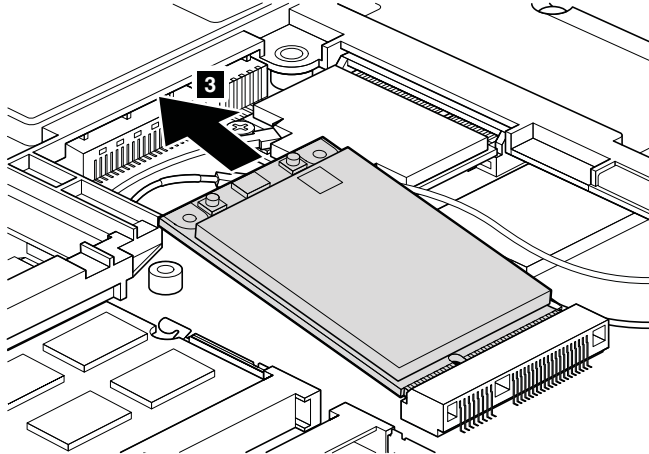

Note: Plug the red cable into the jack marked **MAIN**, and the blue cable into the jack marked **AUX** on the card.

1070 Keyboard

For access, remove these FRUs in order:

- “1010 Battery pack” on page 68
- “1020 Bottom slot cover” on page 70

Table 14. Removal steps of keyboard

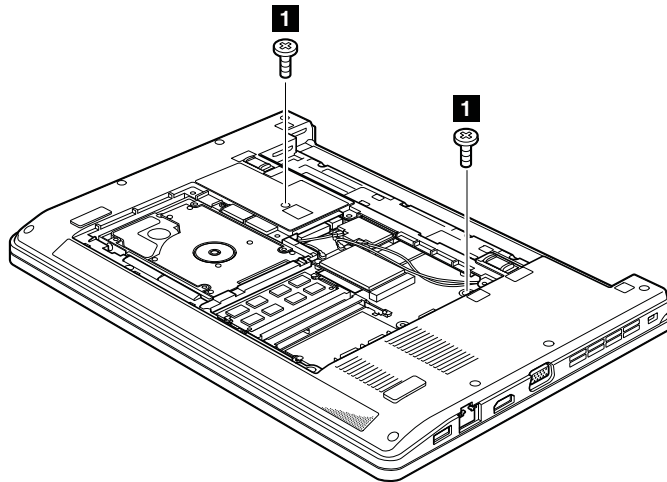

Step	Screw (quantity)	Color	Torque
1	M2 × 5 mm, wafer-head, nylon-coated (2)	Black	0.181 Nm (1.85 kgfcm)

In step **2**, by using a plastic pry tool, push the keyboard out from two square holes in the battery pack slot as shown in this figure.

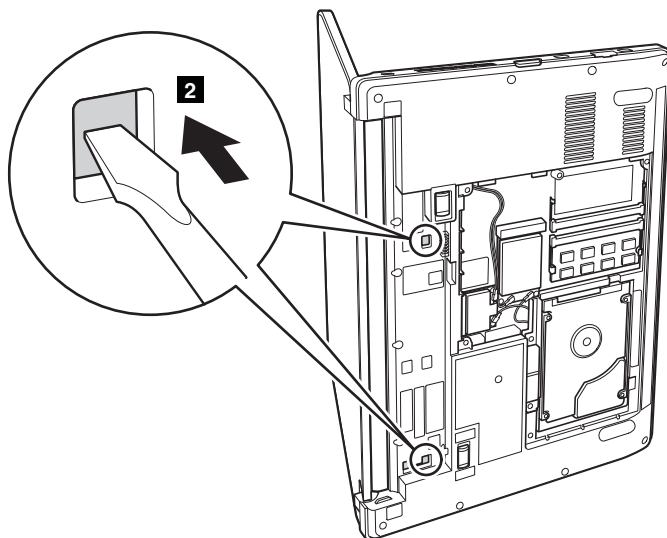

Table 14. Removal steps of keyboard (continued)

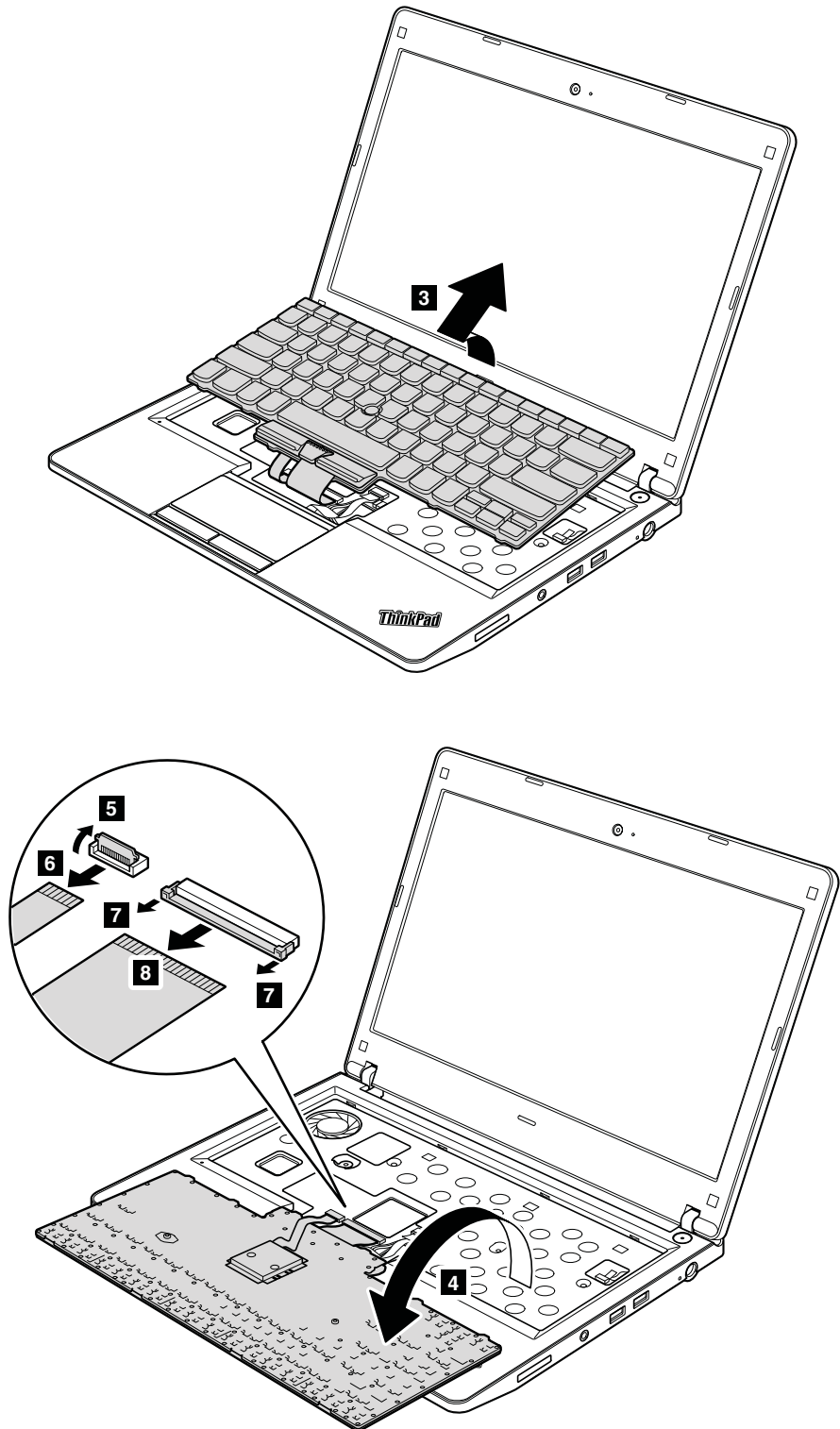
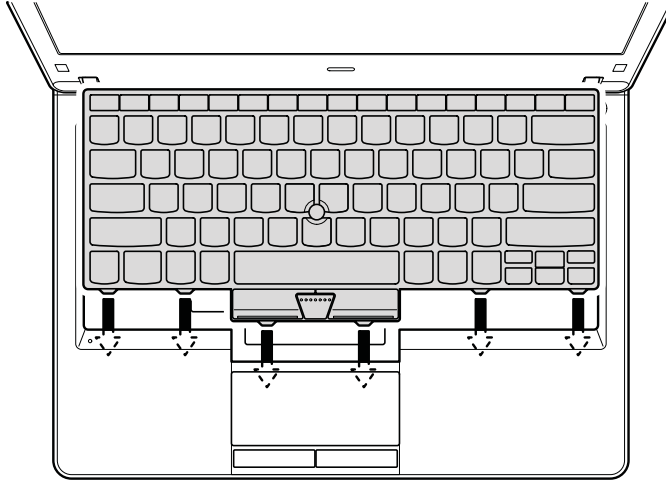

Table 15. Installation steps of keyboard

When installing the keyboard, do as follows:

1. Attach the keyboard connectors.
2. Attach the keyboard so that the keyboard front edges are under the frame as shown in this figure.



3. Secure the keyboard by tightening the screws from the bottom side of the computer.

1080 Top case assembly and microphone module

For access, remove these FRUs in order:

- “1010 Battery pack” on page 68
- “1020 Bottom slot cover” on page 70
- “1040 Hard disk drive (HDD)” on page 73
- “1070 Keyboard” on page 79

Note: Microphone module is attached on the underside of the top case assembly.

Table 16. Removal steps of top case assembly and microphone module

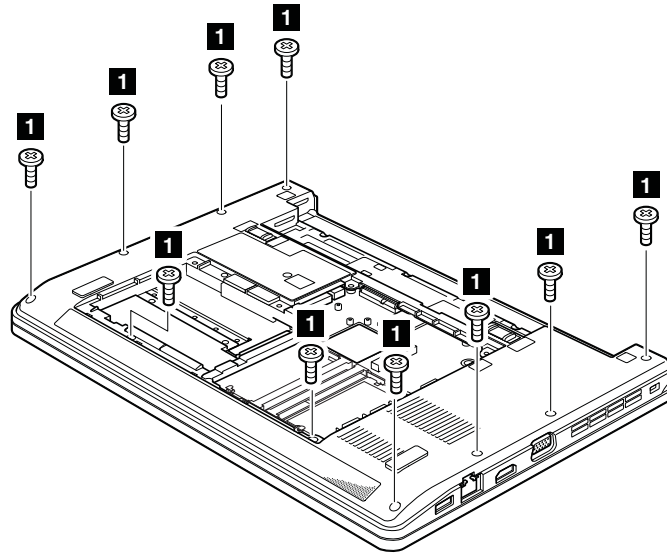

Step	Screw (quantity)	Color	Torque
1	M2 × 5 mm, wafer-head, nylon-coated (10)	Black	0.181 Nm (1.85 kgfcm)

Table 16. Removal steps of top case assembly and microphone module (continued)

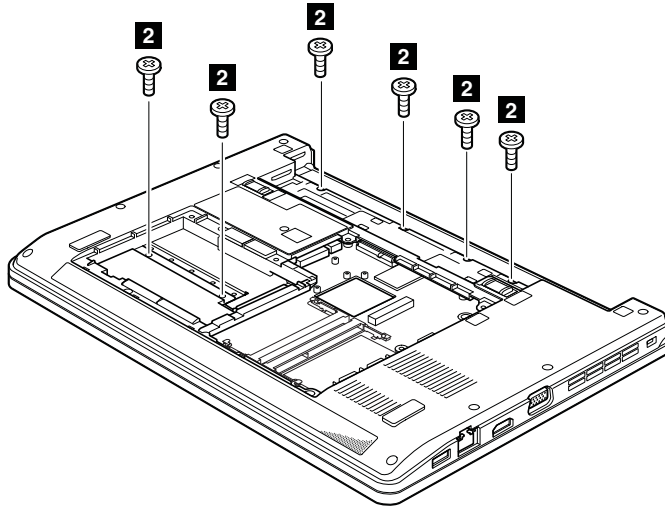

Step	Screw (quantity)	Color	Torque
2	M2 × 3 mm, wafer-head, nylon-coated (6)	Black	0.181 Nm (1.85 kgfcm)

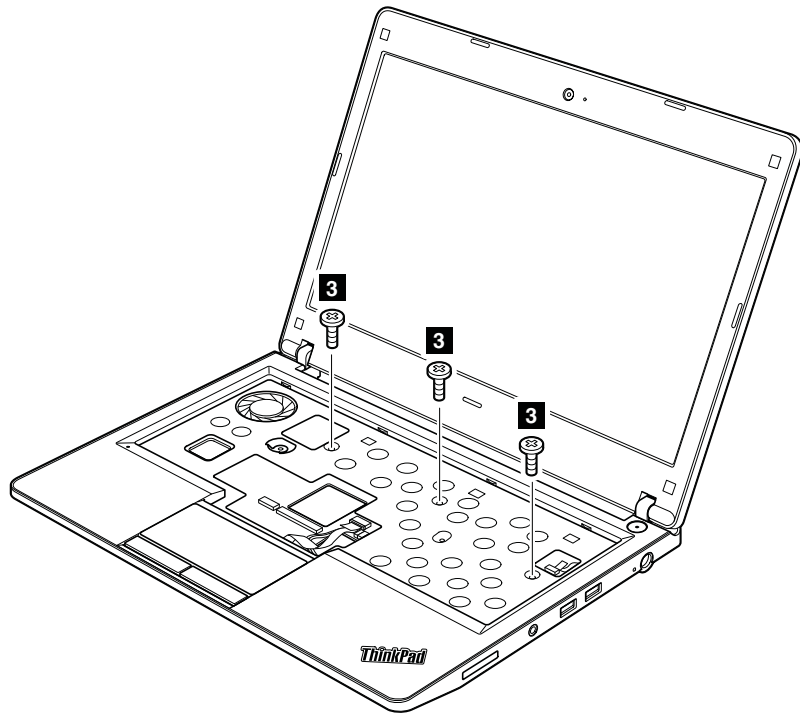

Step	Screw (quantity)	Color	Torque
3	M2 × 3 mm, wafer-head, nylon-coated (3)	Black	0.181 Nm (1.85 kgfcm)

Table 16. Removal steps of top case assembly and microphone module (continued)

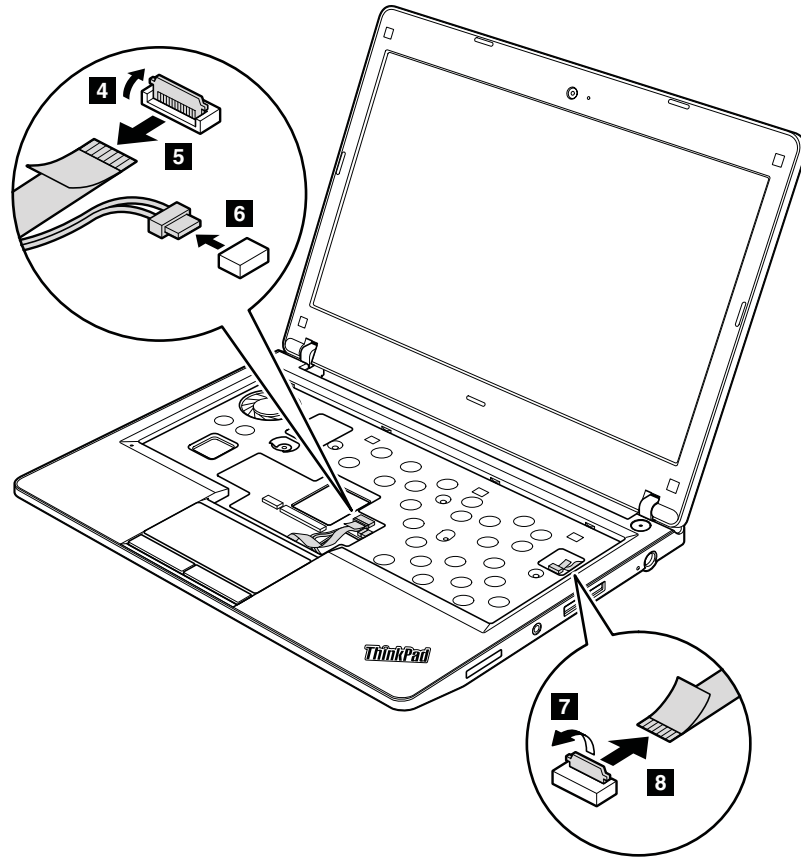

When installing: Make sure that the connectors are attached firmly.

Table 16. Removal steps of top case assembly and microphone module (continued)

In step **5**, push the top case assembly out from the frame by using a plastic pry tool as shown in this figure.

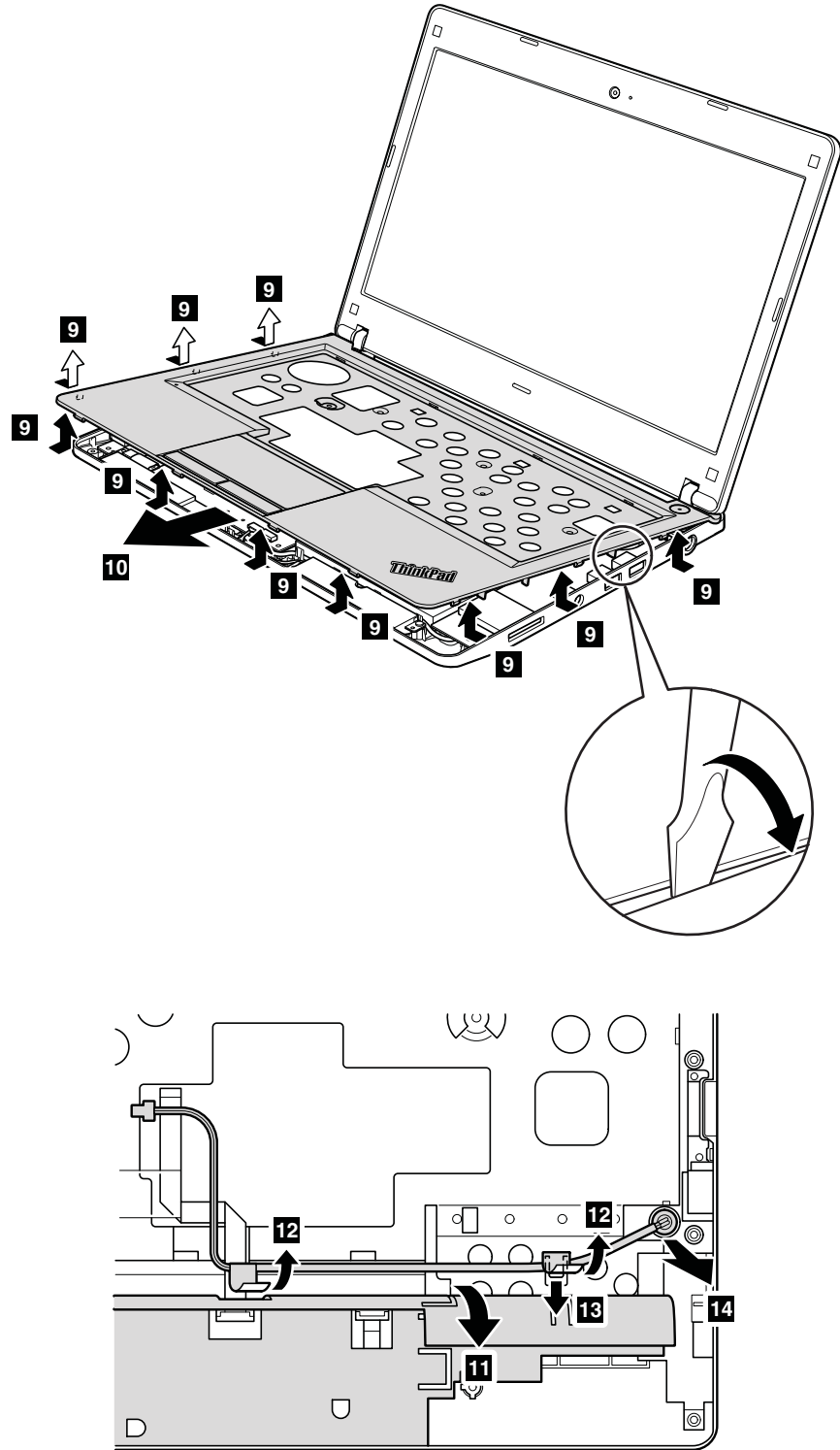

1090 Backup battery

For access, remove these FRUs in order:

- “1010 Battery pack” on page 68
- “1020 Bottom slot cover” on page 70
- “1070 Keyboard” on page 79
- “1080 Top case assembly and microphone module” on page 82

Table 17. Removal steps of backup battery



DANGER

Use only the battery specified in the parts list for your computer. Any other battery could ignite or explode.

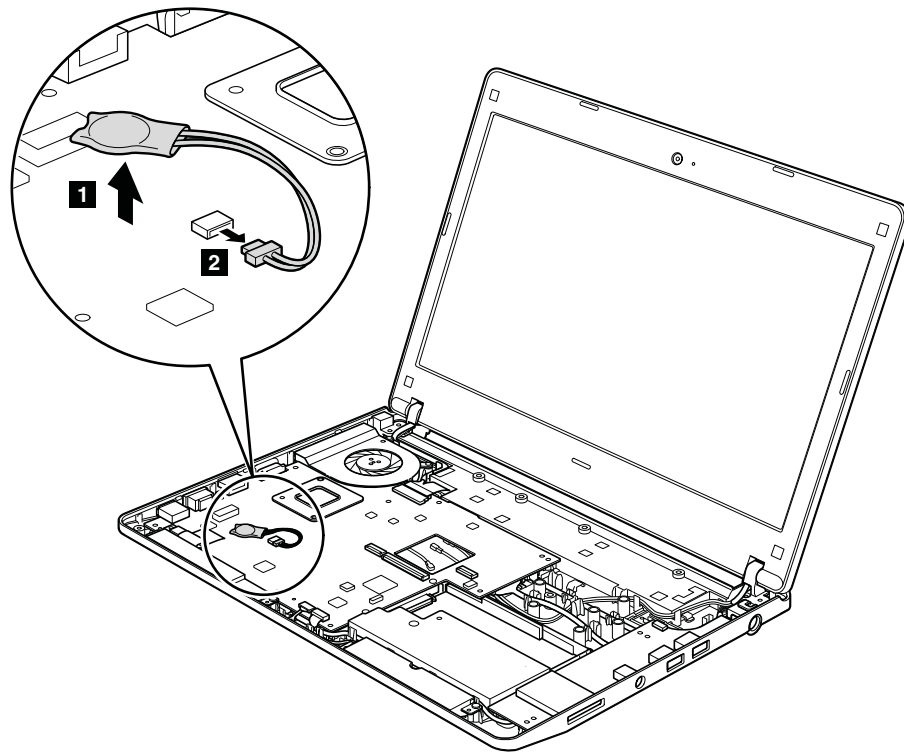

When installing: Make sure that the connector is attached firmly.

1100 Bluetooth daughter card (BDC-2)

- “1010 Battery pack” on page 68
- “1020 Bottom slot cover” on page 70
- “1070 Keyboard” on page 79
- “1080 Top case assembly and microphone module” on page 82

Table 18. Removal steps of BDC-2

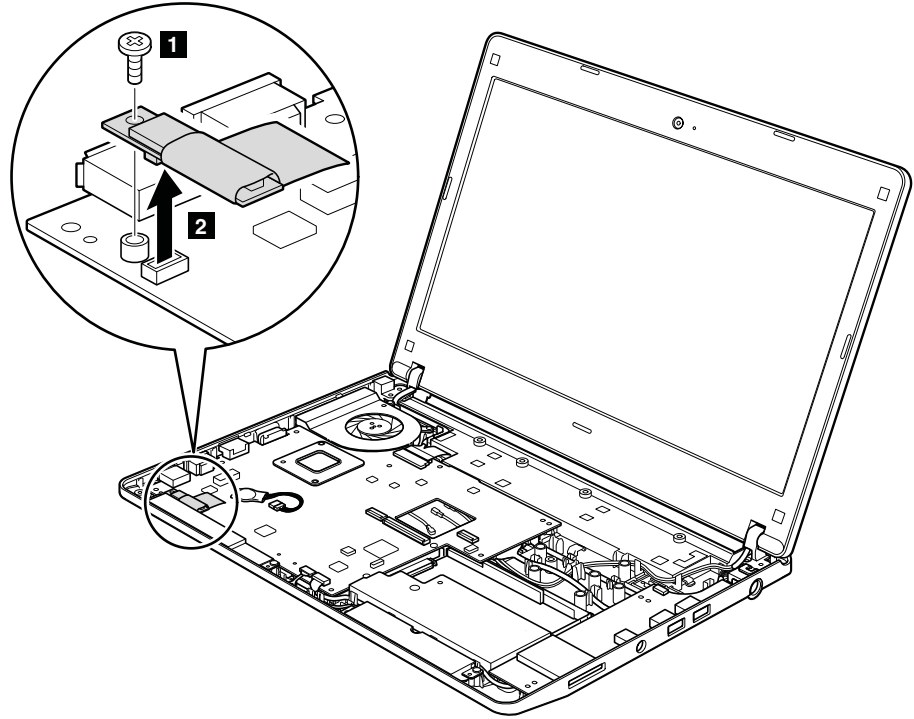

Step	Screw (quantity)	Color	Torque
1	M2 × 3 mm, wafer-head, nylon-coated (1)	Black	0.181 Nm (1.85 kgfcm)

When installing: Make sure that the connector is attached firmly.

1110 Speaker assembly

For access, remove these FRUs in order:

- “1010 Battery pack” on page 68
- “1020 Bottom slot cover” on page 70
- “1070 Keyboard” on page 79
- “1080 Top case assembly and microphone module” on page 82

Table 19. Removal steps of speaker assembly

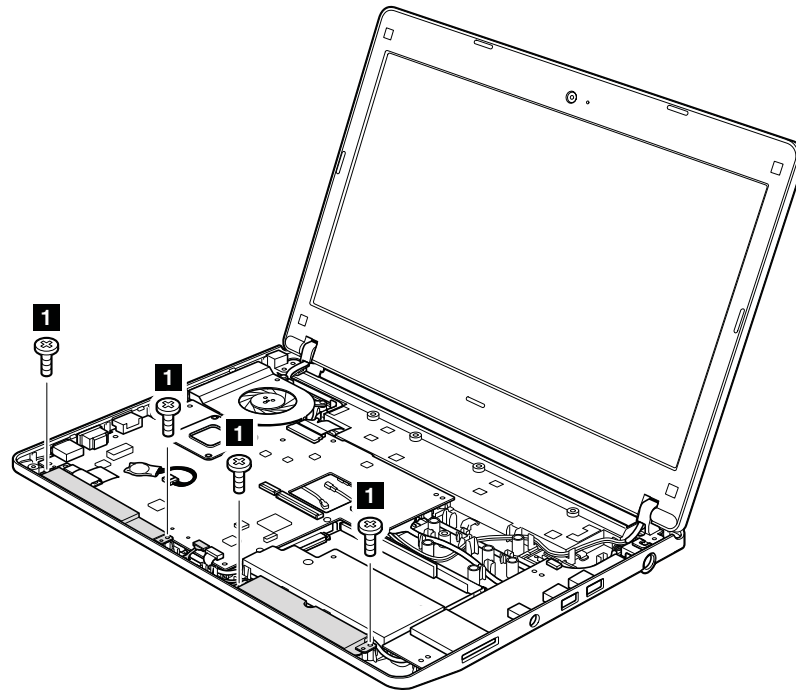

Step	Screw (quantity)	Color	Torque
2	M2 × 3 mm, wafer-head, nylon-coated (4)	Black	0.181 Nm (1.85 kgfcm)

Table 19. Removal steps of speaker assembly (continued)

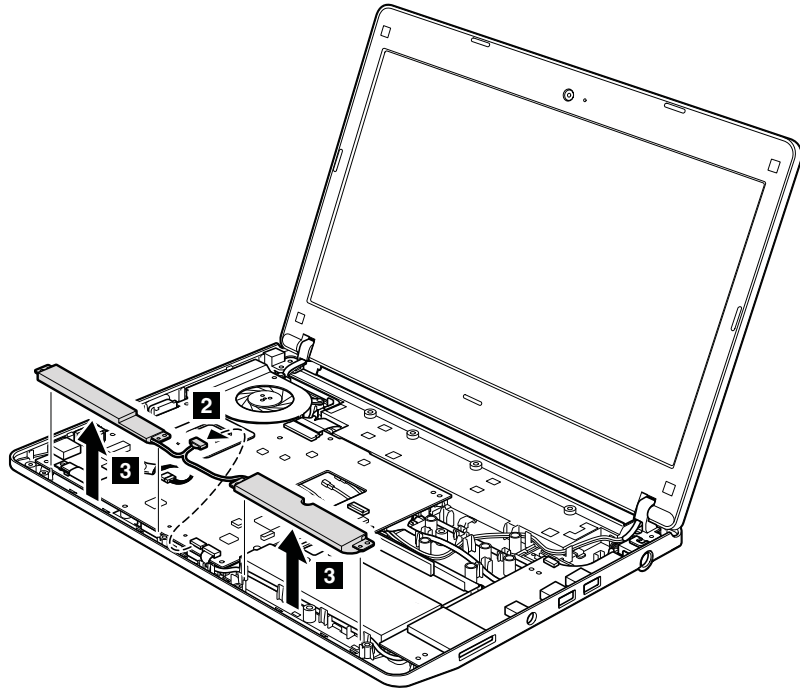

Cable routing: Make sure that the connector is attached firmly and you route the cable as shown in this figure.

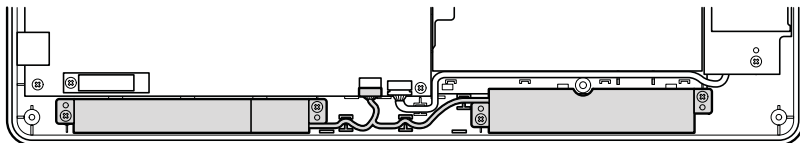

1120 System board and fan assembly

Important notices for handling the system board:

When handling the system board, bear the following in mind.

- The system board has an accelerometer, which can be broken by applying several thousands of G-forces.

Note: Dropping a system board from a height of as little as 6 inches so that it falls flat on a hard bench can subject the accelerometer to as much as 6,000 G's of shock.

- Be careful not to drop the system board on a bench top that has a hard surface, such as metal, wood, or composite.
- If a system board is dropped, you must test it, using PC-Doctor for DOS, to make sure that the HDD Active Protection still functions (see below).

Note: If the test shows that HDD Active Protection is not functioning, be sure to document the drop in any reject report, and replace the system board.

- Avoid rough handling of any kind.
- At every point in the process, be sure not to drop or stack the system board.
- If you put a system board down, be sure to put it only on a padded surface such as an ESD mat or conductive corrugated material.

After replacing the system board, run PC-Doctor for DOS to make sure that HDD Active Protection still functions. The procedure is as follows:

1. Place the computer on a horizontal surface.
2. Run **Diagnostics --> ThinkPad Devices --> HDD Active Protection Test**.

Attention: Do not apply physical shock to the computer while the test is running.

For access, remove these FRUs in order:

- "1010 Battery pack" on page 68
- "1020 Bottom slot cover" on page 70
- "1030 DIMM" on page 72
- "1040 Hard disk drive (HDD)" on page 73
- "1050 PCI Express Mini Card for wireless LAN" on page 75
- "1060 PCI Express Mini Card for wireless WAN" on page 77
- "1070 Keyboard" on page 79
- "1080 Top case assembly and microphone module" on page 82
- "1090 Backup battery" on page 86
- "1100 *Bluetooth* daughter card (BDC-2)" on page 87
- "1110 Speaker assembly" on page 88

Table 20. Removal steps of system board and fan assembly

Following components soldered on the top side of the system board are extremely sensitive. When you service the system board, avoid any kind of rough handling.

For CULV (Customer Ultra-Low Voltage) models:

- a** Accelerometer chip for the HDD Active Protection System™
- b** CPU
- c** GMCH (Graphics Memory Controller Hub)
- d** ICH (I/O Controller Hub)

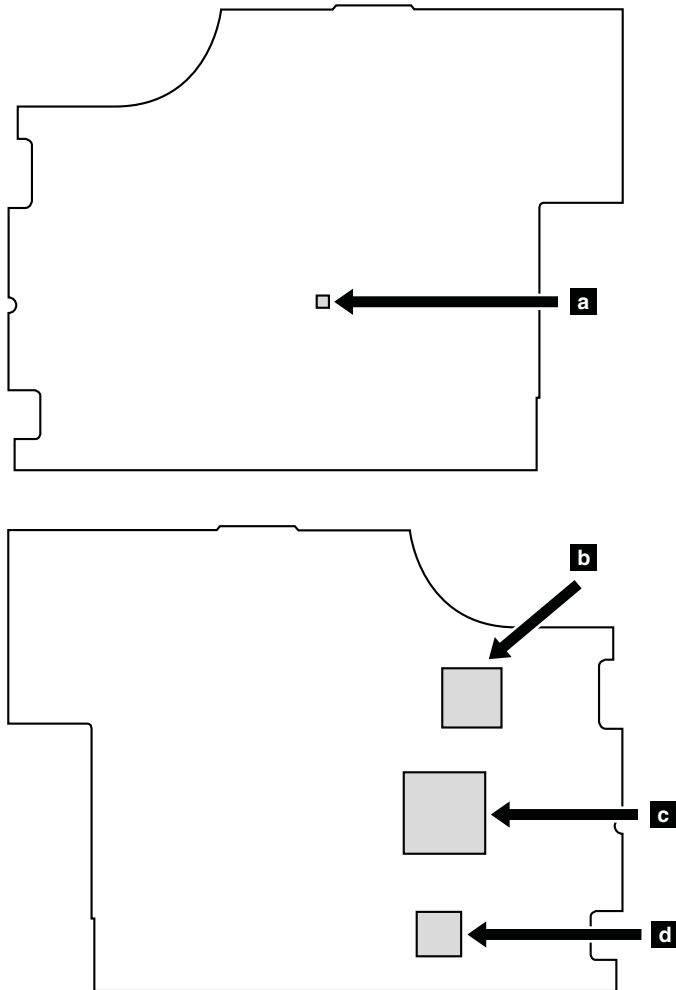

Table 20. Removal steps of system board and fan assembly (continued)

For AMD models:

- a** CPU
- b** North Bridge
- c** South Bridge
- d** Accelerometer chip for the HDD Active Protection System

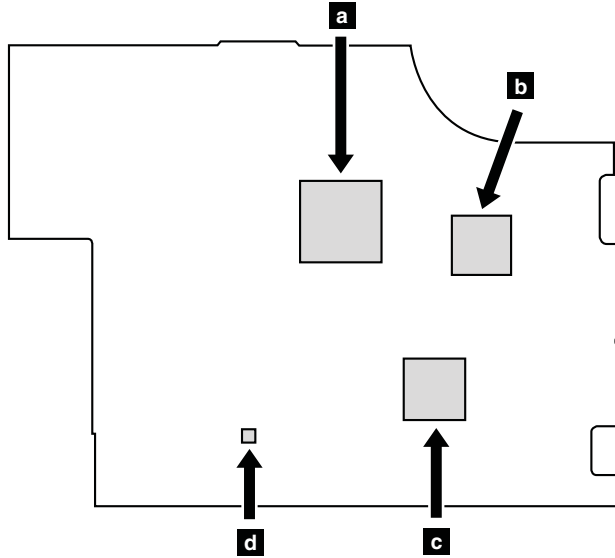
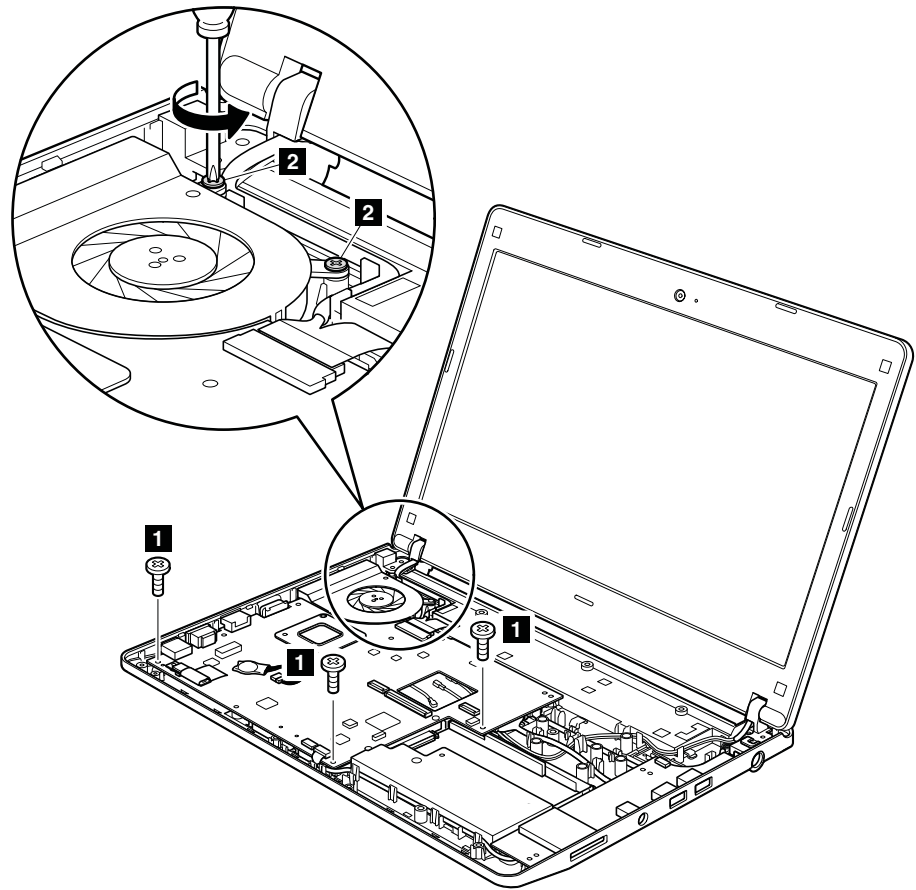

Table 20. Removal steps of system board and fan assembly (continued)



Step	Screw (quantity)	Color	Torque
1	M2 × 3 mm, wafer-head, nylon-coated (3)	Black	0.181 Nm (1.85 kgfcm)

Note: Loosen the screws **2**, but do not remove them.

Table 20. Removal steps of system board and fan assembly (continued)

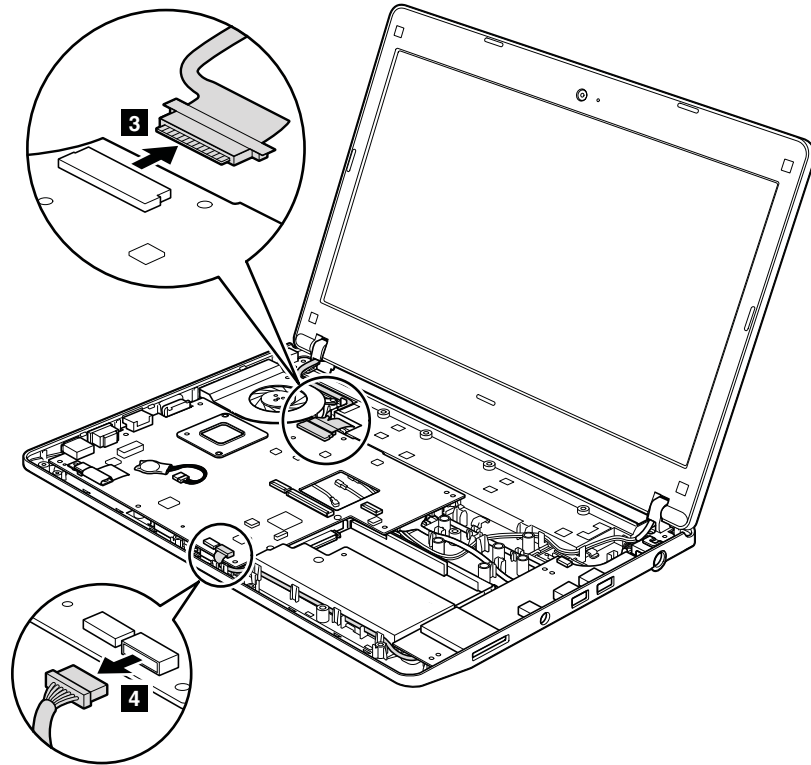

When installing: Make sure that the connectors are attached firmly.

Table 20. Removal steps of system board and fan assembly (continued)

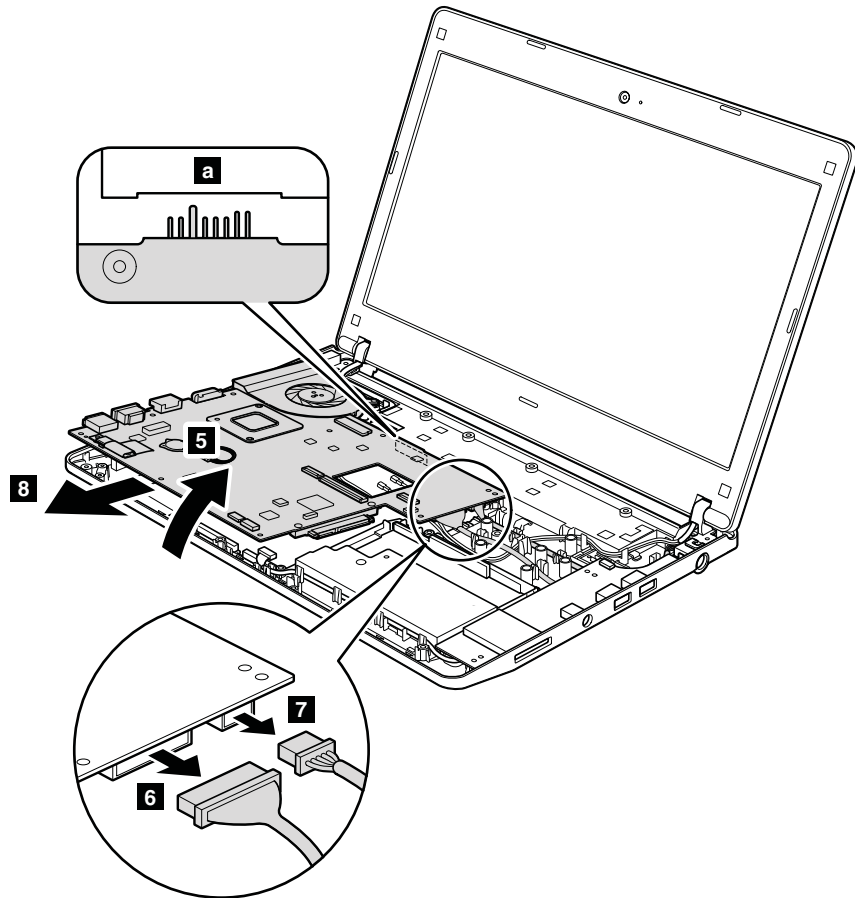

When installing: Attach the system board so that the battery pins of the system board are attached firmly to the guide hole of the base cover as shown in **a** in this figure.

Make sure that the connectors are attached firmly.

Table 20. Removal steps of system board and fan assembly (continued)

Note: Loosen the screws **9**, but do not remove them.

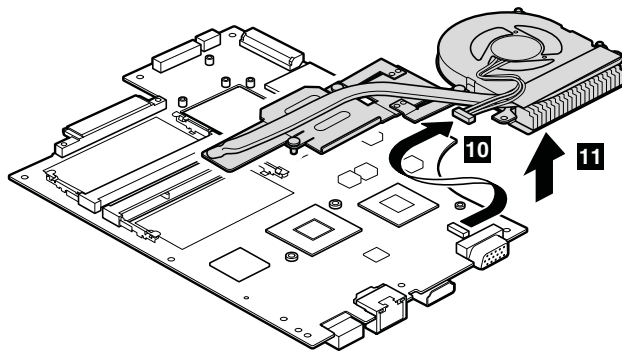
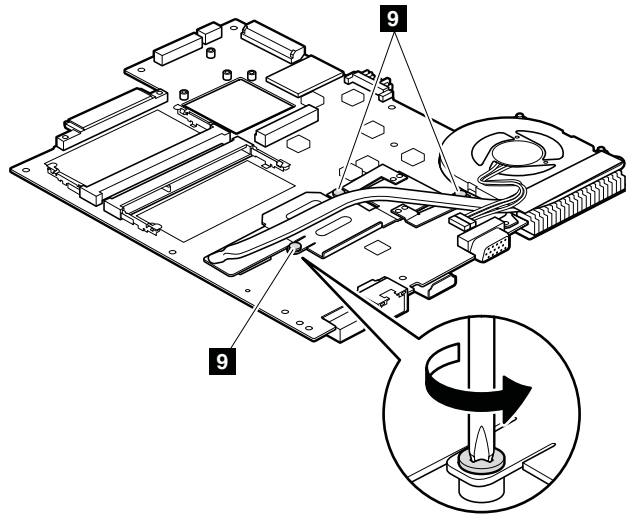
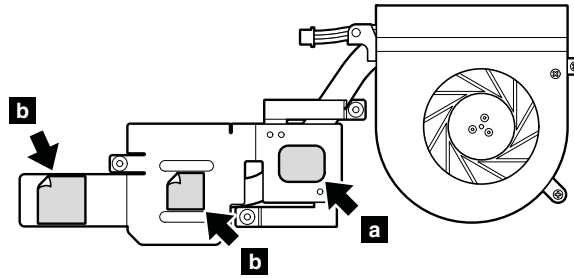

Table 20. Removal steps of system board and fan assembly (continued)

When installing:

- Before you attach the fan assembly to the computer, apply thermal grease, at an amount of 0.2 grams, on the part marked **a** as in the following figure. Either too much or too less application of grease can cause a thermal problem due to imperfect contact with a component. You need to peel the thin film off from the rubbers **b**.

For MT0196 and MT0492:



For MT0197:

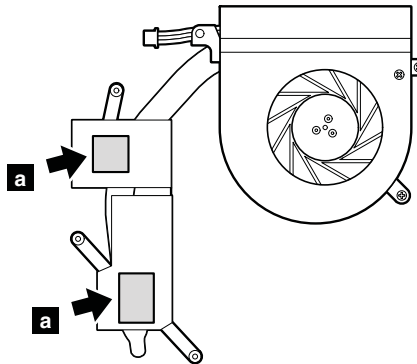

- Make sure that the fan connector is attached firmly.

1130 I/O card assembly, audio cable, and I/O cable

For access, remove these FRUs in order:

- “1010 Battery pack” on page 68
- “1020 Bottom slot cover” on page 70
- “1040 Hard disk drive (HDD)” on page 73
- “1050 PCI Express Mini Card for wireless LAN” on page 75
- “1060 PCI Express Mini Card for wireless WAN” on page 77
- “1070 Keyboard” on page 79
- “1080 Top case assembly and microphone module” on page 82
- “1110 Speaker assembly” on page 88
- “1120 System board and fan assembly” on page 90

Table 21. Removal steps of I/O card assembly, audio cable, and I/O cable

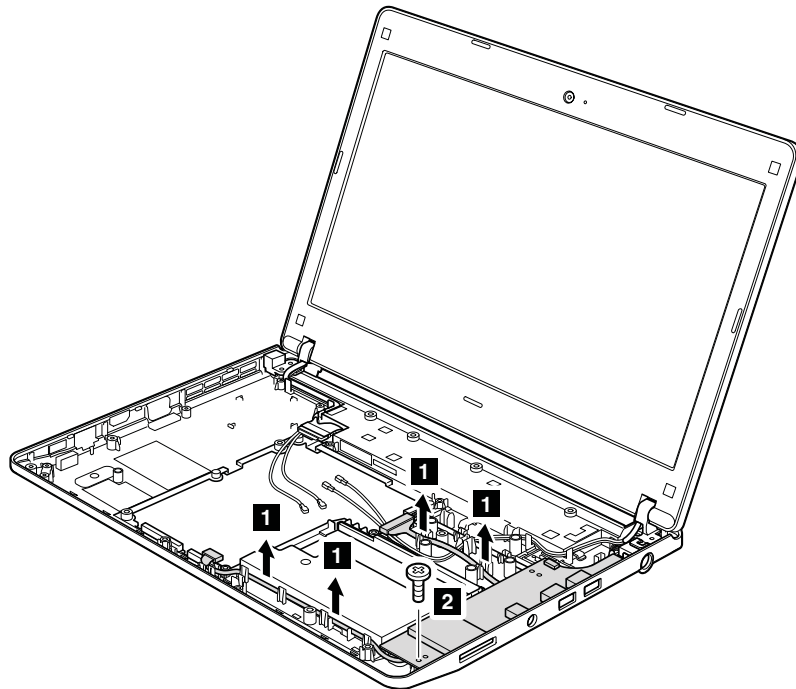

Step	Screw (quantity)	Color	Torque
2	M2 × 3 mm, wafer-head, nylon-coated (1)	Black	0.181 Nm (1.85 kgfcm)

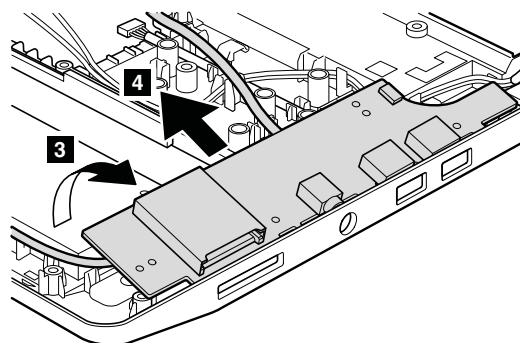
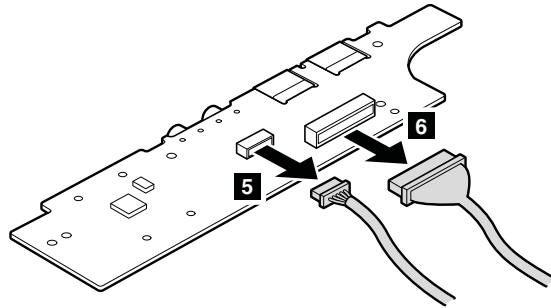
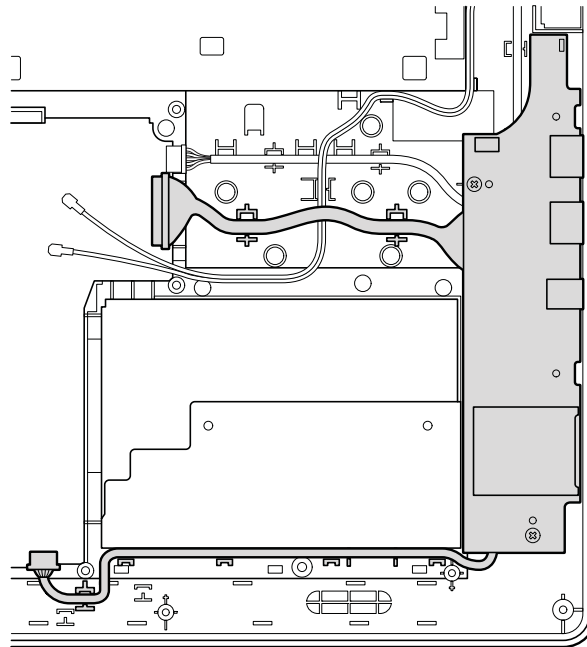

Table 21. Removal steps of I/O card assembly, audio cable, and I/O cable (continued)



Cable routing: Make sure that the connectors are attached firmly and you route the cables as shown in this figure.



1140 LCD unit

For access, remove these FRUs in order:

- “1010 Battery pack” on page 68
- “1020 Bottom slot cover” on page 70
- “1040 Hard disk drive (HDD)” on page 73
- “1050 PCI Express Mini Card for wireless LAN” on page 75
- “1060 PCI Express Mini Card for wireless WAN” on page 77
- “1070 Keyboard” on page 79
- “1080 Top case assembly and microphone module” on page 82
- “1110 Speaker assembly” on page 88
- “1120 System board and fan assembly” on page 90

Table 22. Removal steps of LCD unit

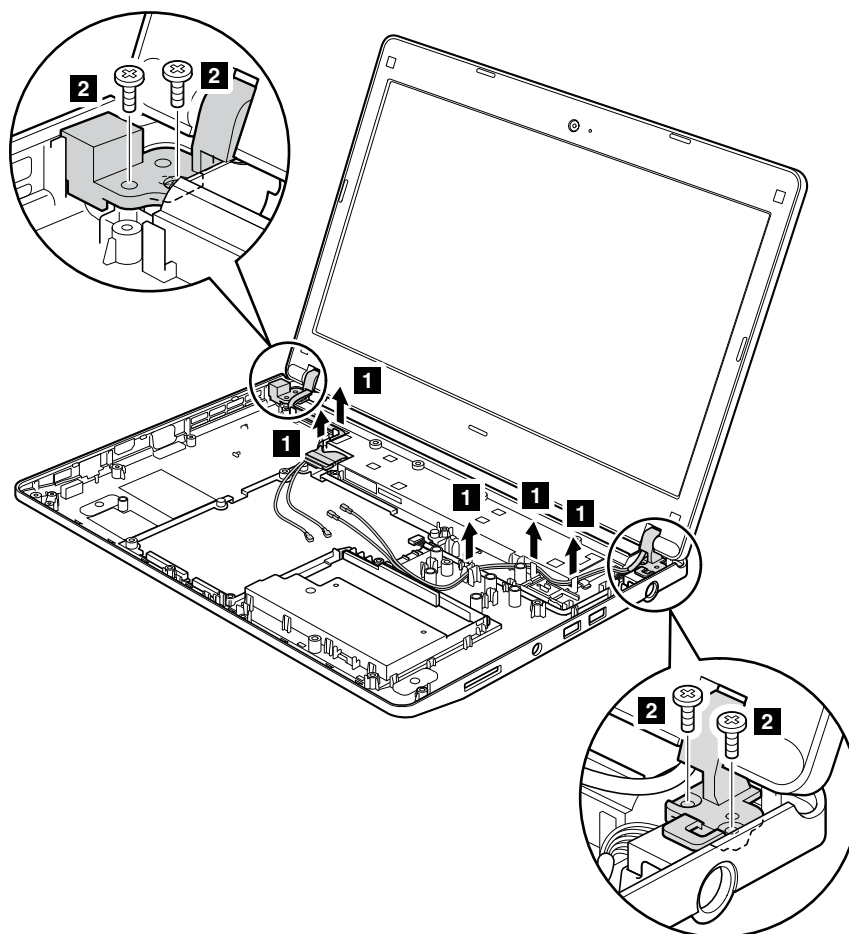

Step	Screw (quantity)	Color	Torque
2	M2 × 5 mm, wafer-head, nylon-coated (2)	Black	0.181 Nm (1.85 kgfcm)

Table 22. Removal steps of LCD unit (continued)

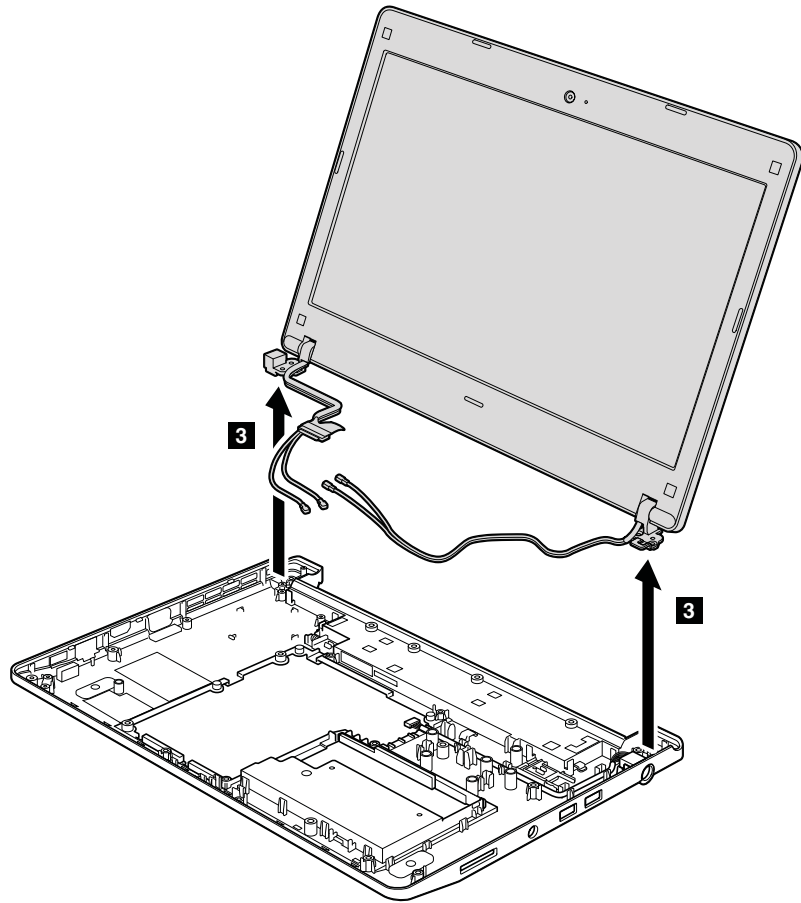

Cable routing: Make sure that the cables are attached to the cable guides as shown in this figure. When you route the cables, make sure that they are not subjected to any tension. Tension could cause the cables to be damaged by the cable guides, or a wire to be broken.

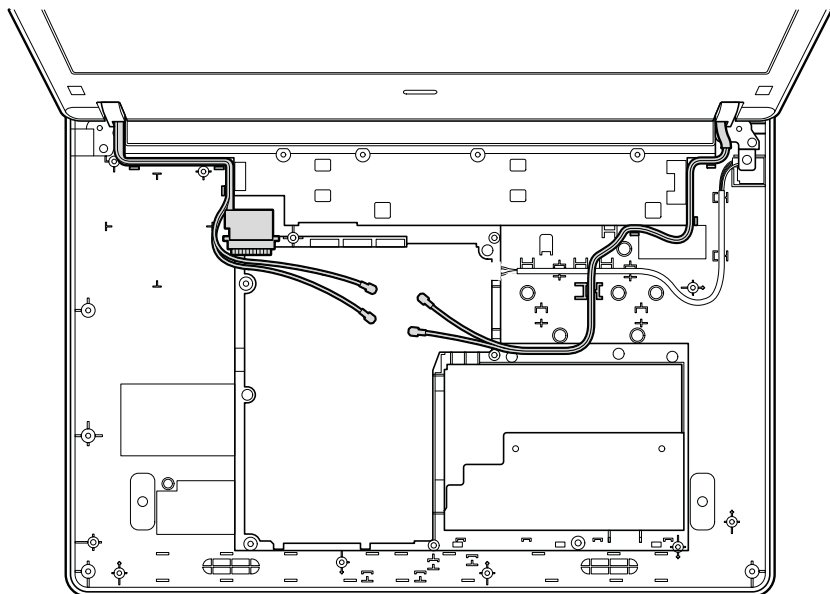

1150 Base cover assembly and DC-in cable

For access, remove these FRUs in order:

- "1010 Battery pack" on page 68
- "1020 Bottom slot cover" on page 70
- "1040 Hard disk drive (HDD)" on page 73
- "1050 PCI Express Mini Card for wireless LAN" on page 75
- "1060 PCI Express Mini Card for wireless WAN" on page 77
- "1070 Keyboard" on page 79
- "1080 Top case assembly and microphone module" on page 82
- "1110 Speaker assembly" on page 88
- "1120 System board and fan assembly" on page 90
- "1140 LCD unit" on page 100

Table 23. Removal steps of base cover assembly and DC-in cable

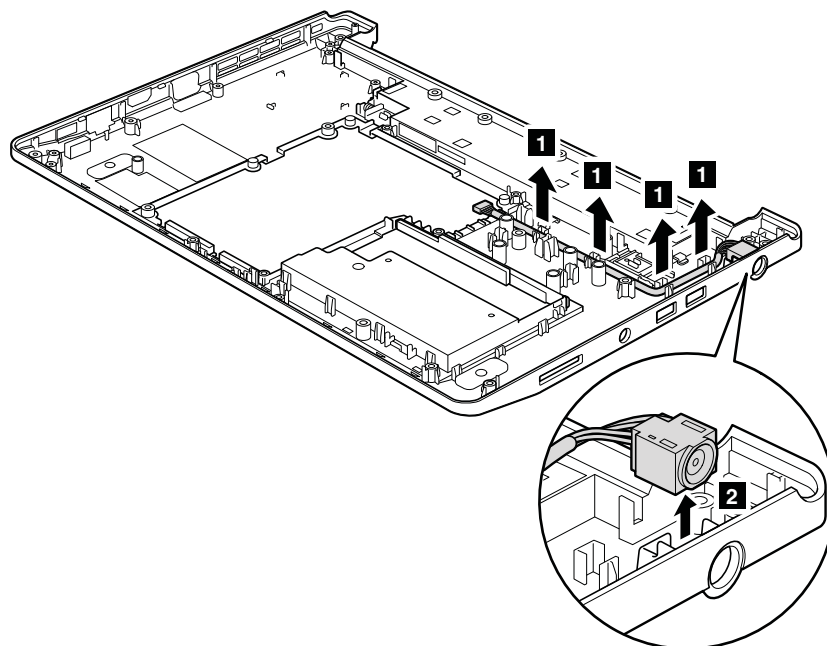
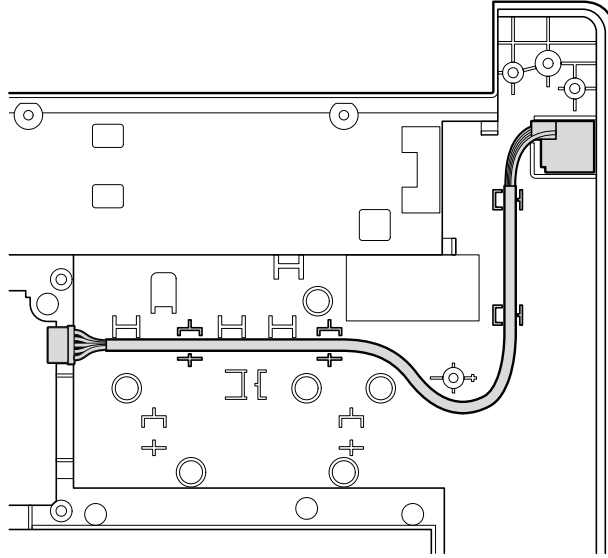

Table 23. Removal steps of base cover assembly and DC-in cable (continued)

Cable routing: Make sure that the cable is attached to the cable guides as shown in this figure. When you route the cables, make sure that they are not subjected to any tension. Tension could cause the cables to be damaged by the cable guides, or a wire to be broken.



Note: Applying labels to the base cover

The new base cover FRU is shipped with a kit containing labels of several kinds. When you replace the base cover, you need to apply the following labels:

- 4** Information label under battery
- 6** FCC label
- 7** Homologation label
- 13** Serial number blank label

Following labels need to be peeled off from the old base cover, and need to be put on the new base cover.

- 1** Ethernet label
- 2** Windows license label (COA)
- 3** SID card label
- 5** SIM ICCID label
- 8** Brazil ANATEL wireless LAN label
- 9** Israel label
- 10** SIRM label
- 11** China wireless WAN label
- 12** Brazil ANATEL *Bluetooth* label
- 14** Wireless WAN label
- 15** Wireless LAN label

For some models, you also need to apply one or two FCC labels. Check the old base cover; if it has one or two FCC labels, find duplicates of them in the label kit and apply them to the new base cover.

For the location of each label, refer the following figure:

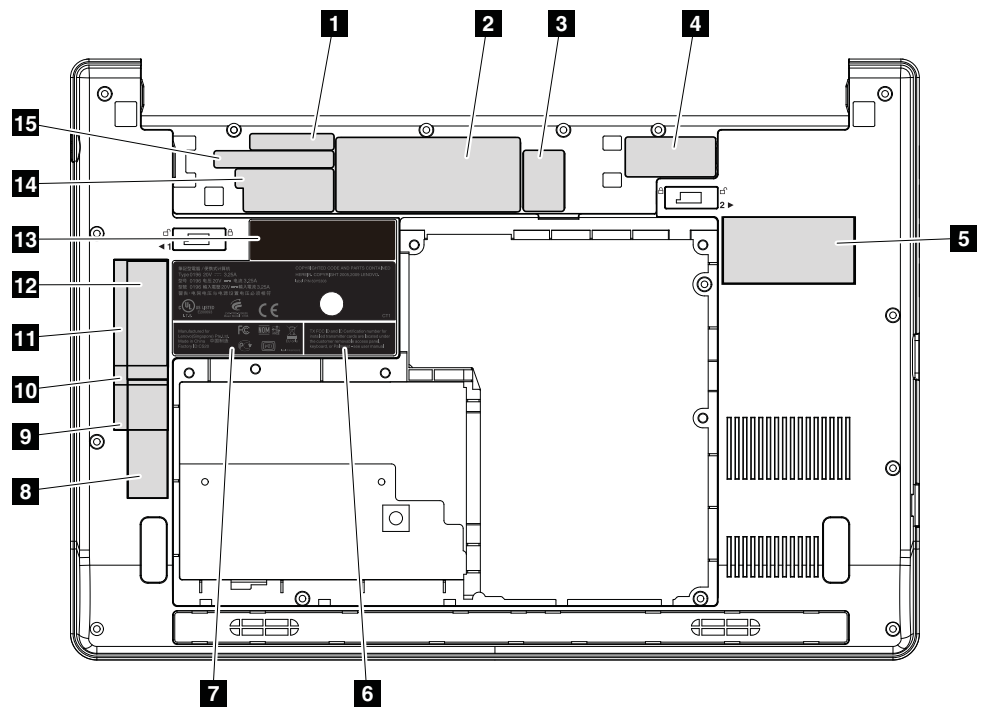



2010 LCD bezel assembly

For access, remove this FRU:

- "1010 Battery pack" on page 68

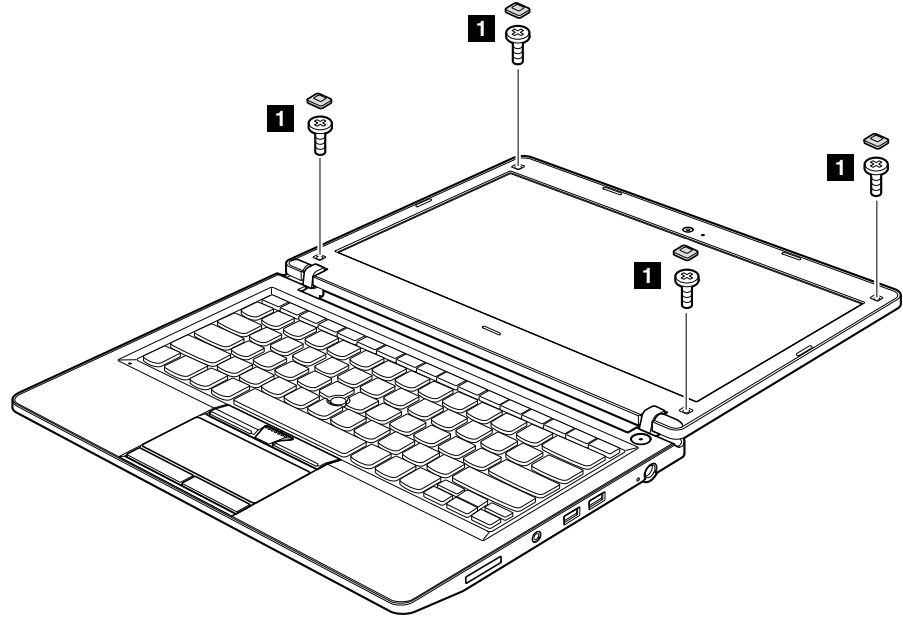
Table 24. Removal steps of LCD bezel assembly



Step	Screw cap	Screw (quantity)	Color	Torque
1		M2 × 3 mm, wafer-head, nylon-coated (4)	Black	0.181 Nm (1.85 kgfcm)

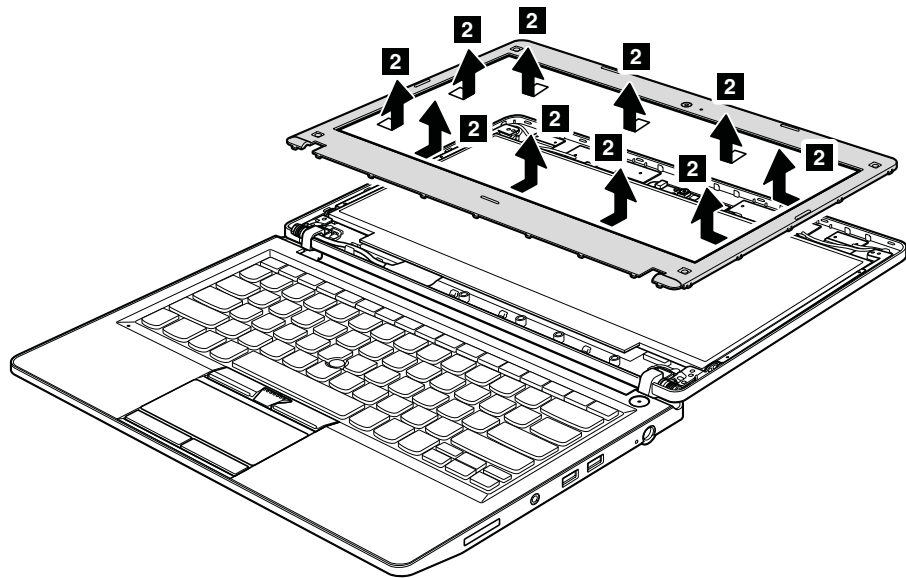

2020 Integrated camera

For access, remove these FRUs in order:

- “1010 Battery pack” on page 68
- “2010 LCD bezel assembly” on page 105

Table 25. Removal steps of integrated camera

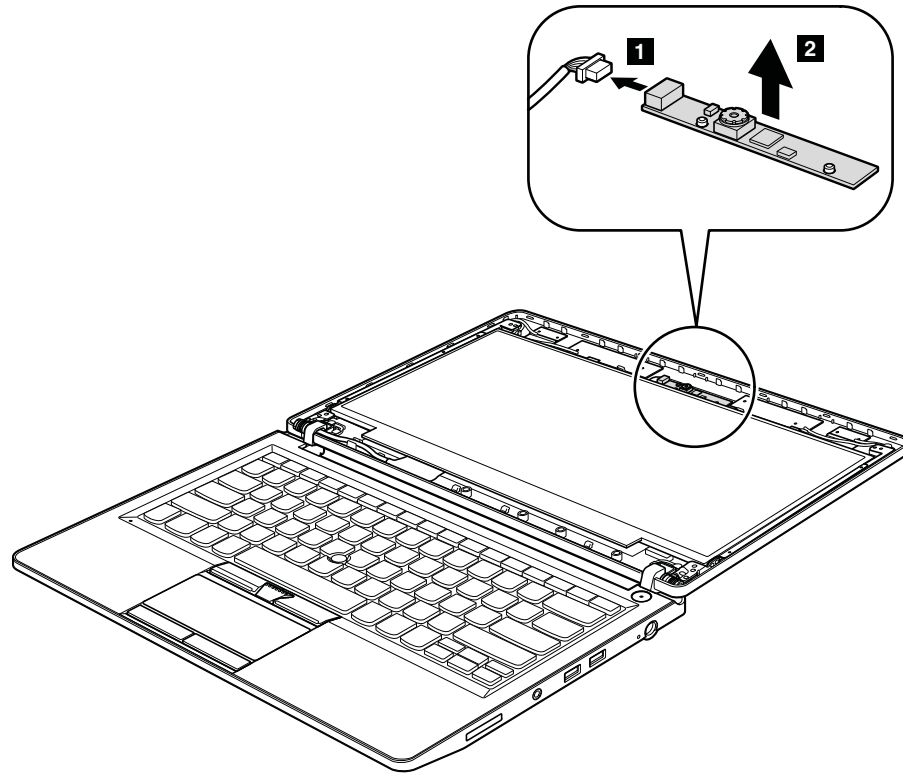

When installing: Make sure that the connector of the integrated camera is attached firmly.

2030 LCD panel and LCD cable

For access, remove these FRUs in order:

- “1010 Battery pack” on page 68
- “1020 Bottom slot cover” on page 70
- “1040 Hard disk drive (HDD)” on page 73
- “1050 PCI Express Mini Card for wireless LAN” on page 75
- “1060 PCI Express Mini Card for wireless WAN” on page 77
- “1070 Keyboard” on page 79
- “1080 Top case assembly and microphone module” on page 82
- “1110 Speaker assembly” on page 88
- “1120 System board and fan assembly” on page 90
- “1140 LCD unit” on page 100

Table 26. Removal steps of LCD panel and LCD cable

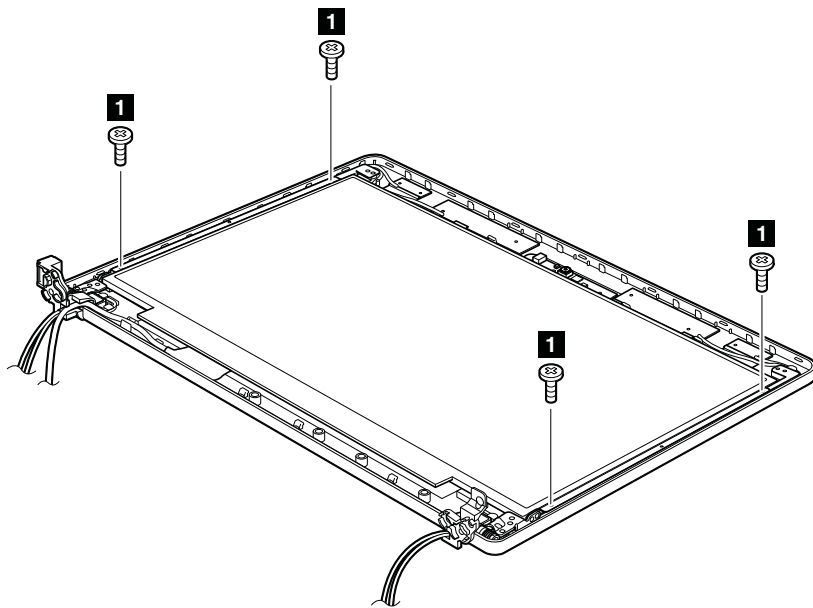

Step	Screw (quantity)	Color	Torque
1	M2 × 3 mm, wafer-head, nylon-coated (4)	Silver	0.181 Nm (1.85 kgfcm)

Table 26. Removal steps of LCD panel and LCD cable (continued)

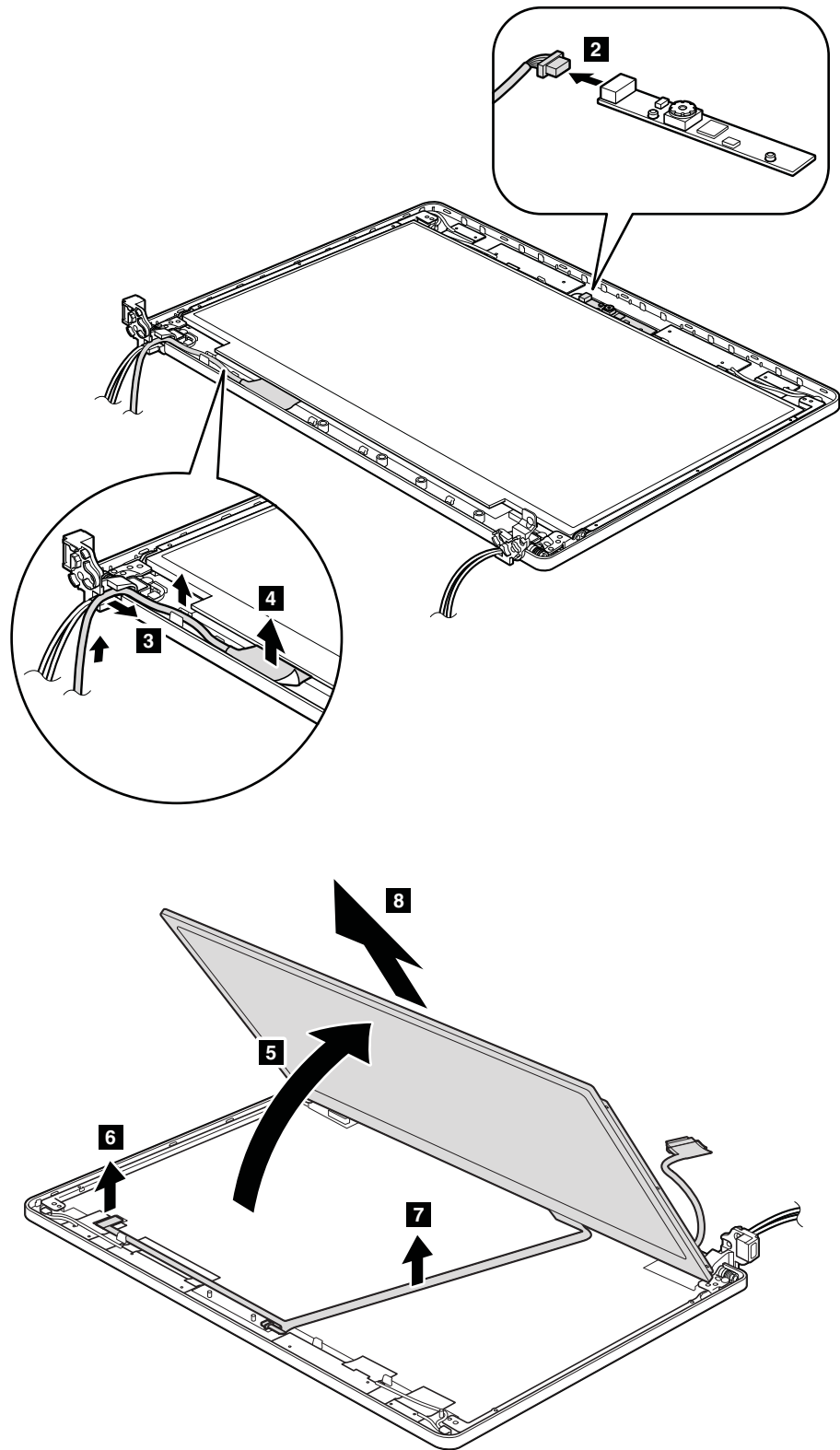
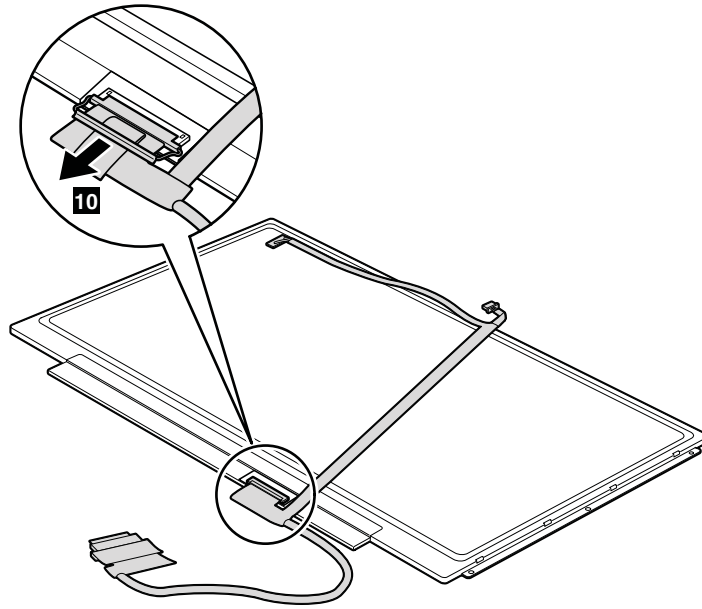

Table 26. Removal steps of LCD panel and LCD cable (continued)



2070 Hinge kit

For access, remove these FRUs in order:

- "1010 Battery pack" on page 68
- "1020 Bottom slot cover" on page 70
- "1040 Hard disk drive (HDD)" on page 73
- "1050 PCI Express Mini Card for wireless LAN" on page 75
- "1060 PCI Express Mini Card for wireless WAN" on page 77
- "1070 Keyboard" on page 79
- "1080 Top case assembly and microphone module" on page 82
- "1110 Speaker assembly" on page 88
- "1120 System board and fan assembly" on page 90
- "1140 LCD unit" on page 100
- "2030 LCD panel and LCD cable" on page 107

Table 27. Removal steps of hinge kit

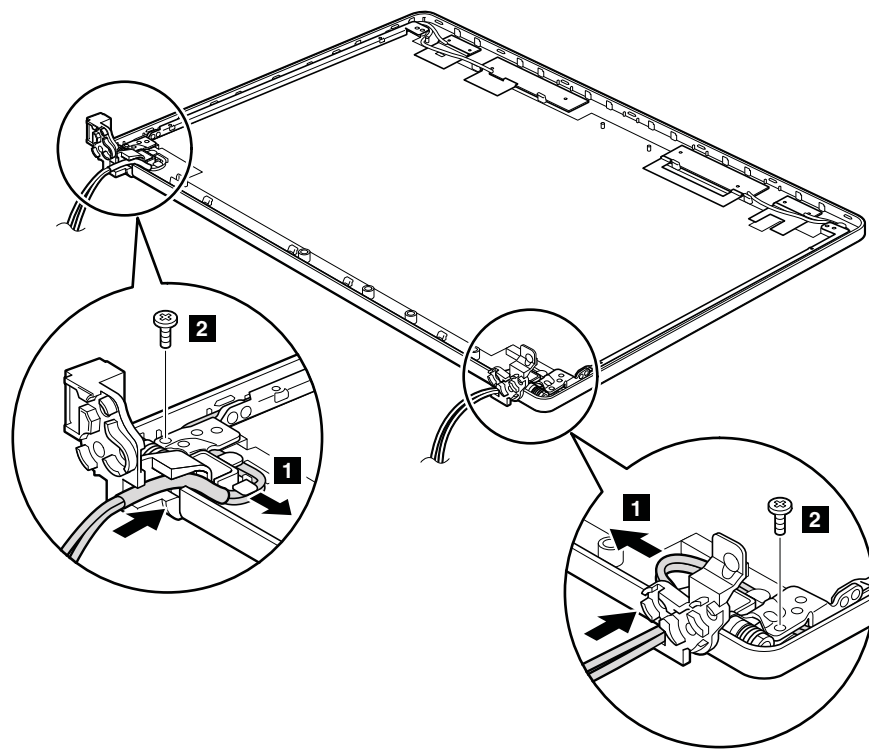

Step	Screw (quantity)	Color	Torque
2	M2 × 3 mm, wafer-head, nylon-coated (2)	Black	0.181 Nm (1.85 kgfcm)

Table 27. Removal steps of hinge kit (continued)

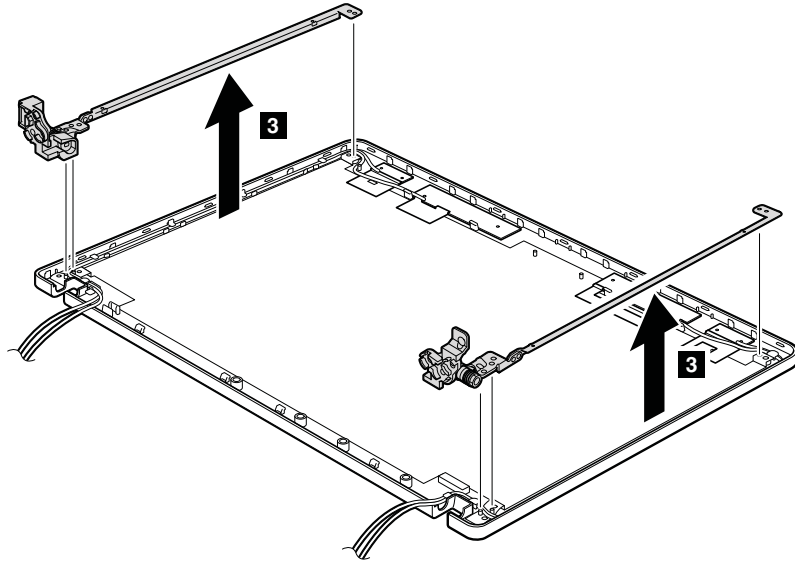

2050 Wireless LAN antenna assembly, wireless WAN antenna assembly, and LCD rear cover assembly

For access, remove these FRUs in order:

- "1010 Battery pack" on page 68
- "1020 Bottom slot cover" on page 70
- "1040 Hard disk drive (HDD)" on page 73
- "1050 PCI Express Mini Card for wireless LAN" on page 75
- "1060 PCI Express Mini Card for wireless WAN" on page 77
- "1070 Keyboard" on page 79
- "1080 Top case assembly and microphone module" on page 82
- "1110 Speaker assembly" on page 88
- "1120 System board and fan assembly" on page 90
- "1140 LCD unit" on page 100
- "2030 LCD panel and LCD cable" on page 107
- "2070 Hinge kit" on page 110

Table 28. Removal steps of wireless LAN antenna assembly, wireless WAN antenna assembly, and LCD rear cover assembly

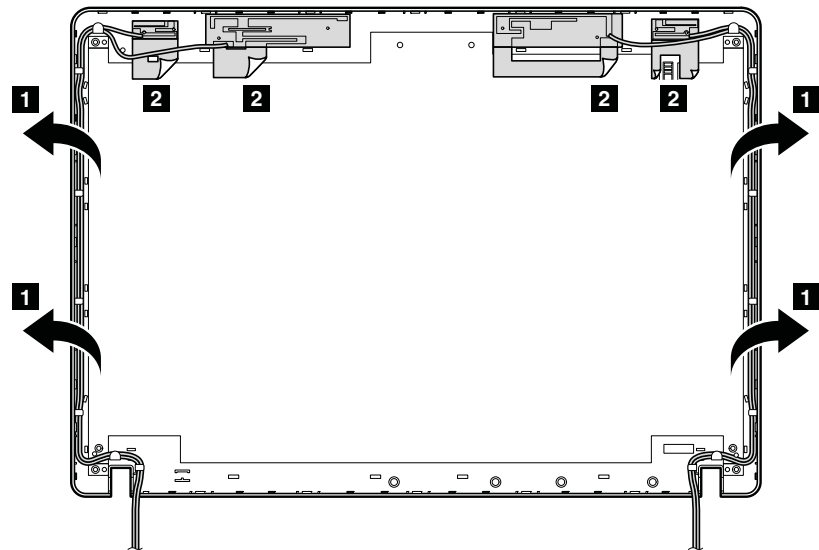
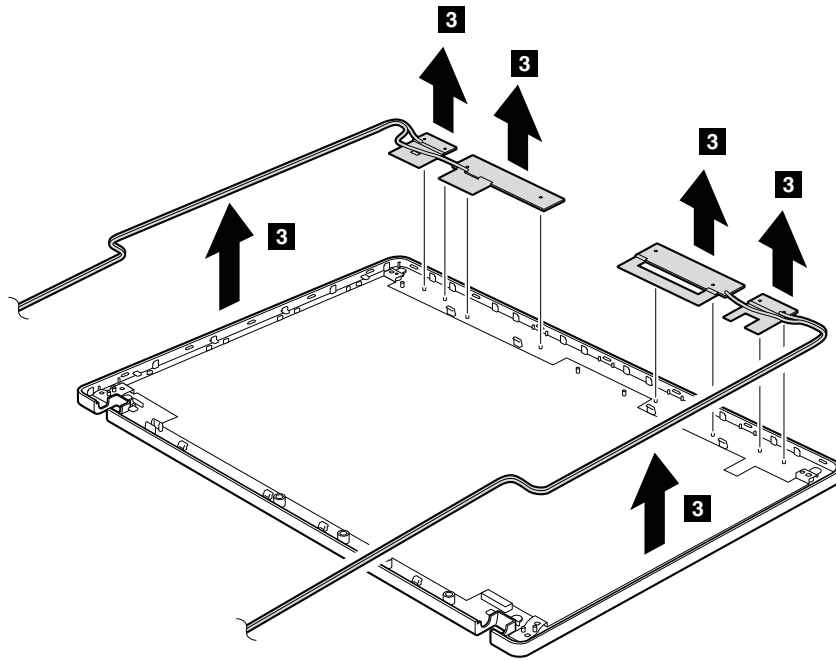
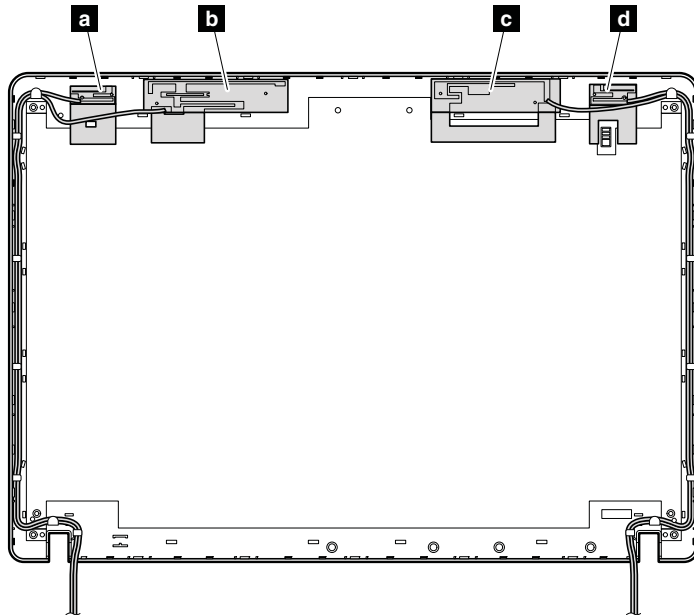

Table 28. Removal steps of wireless LAN antenna assembly, wireless WAN antenna assembly, and LCD rear cover assembly (continued)



Cable routing: When you install the antenna assembly, route the cables as shown in the figures below. As you route the cables, make sure that they are not subjected to any tension. Tension could cause the cables to be damaged by the cable guides, or a wire to be broken.

- a** : Wireless LAN MAIN antenna (gray)
- b** : Wireless WAN MAIN antenna (red)
- c** : Wireless WAN AUX antenna (blue)
- d** : Wireless LAN AUX antenna (black)



Locations

This chapter presents the location of ThinkPad Edge 13" features and hardware.

Front view

- 1** Integrated camera (for some models)
- 2** Power switch
- 3** AC power connector
- 4** Status indicators
Note: For the description of each indicator, see "Status indicators" on page 59.
- 5** Universal serial bus (USB) connectors
- 6** Combo audio jack
- 7** Media Card Reader slot
- 8** Status indicators
Note: For the description of each indicator, see "Status indicators" on page 59.
- 9** TrackPoint pointing stick
- 10** TrackPoint buttons
- 11** Touch pad buttons
- 12** Touch pad
- 13** UltraNav
- 14** Built-in microphone

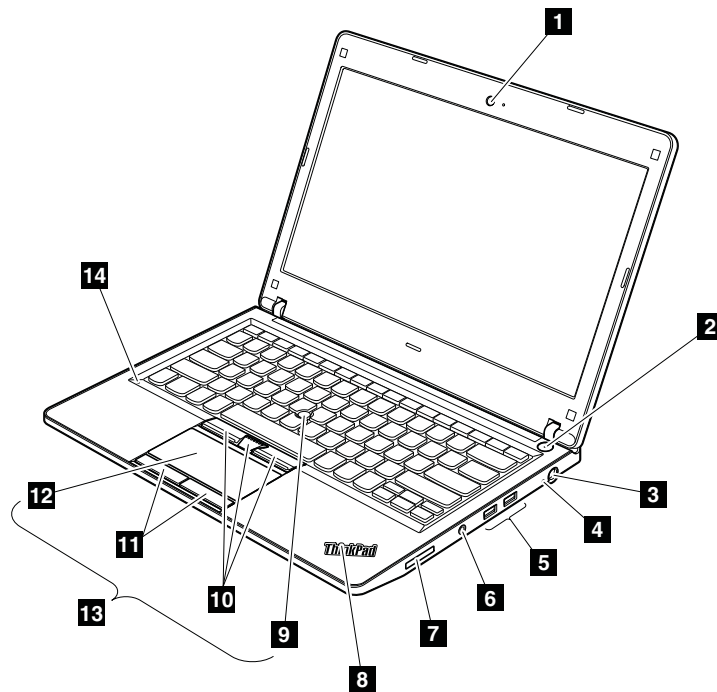

Bottom view

- 1** Battery pack latch
- 2** Battery pack
- 3** Security keyhole
- 4** External monitor connector
- 5** HDMI port
- 6** RJ-45 (Ethernet) connector
- 7** USB connector
- 8** Built-in stereo speakers
- 9** HDD slot door

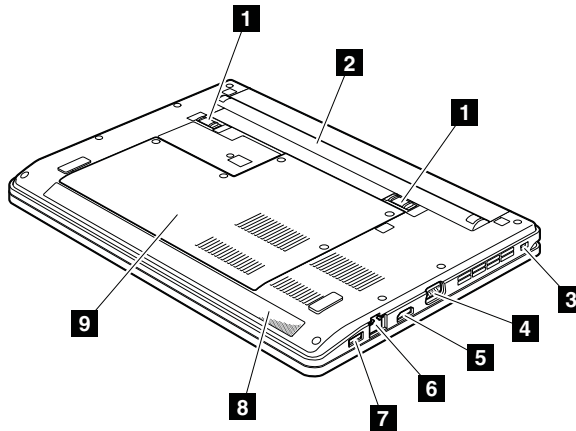

Parts list

This chapter contains following lists of the service parts.

- “Overall” on page 118
- “LCD FRUs” on page 126
- “Keyboard” on page 129
- “AC adapters” on page 130
- “Miscellaneous parts” on page 130
- “Power cords” on page 131
- “Recovery discs” on page 132
- “Common service tools” on page 136

Notes:

- Each FRU is available for all types or models, unless specific types or models are specified.
- FRU with specific models listed and described as xxU (where U is an example of a country designator) should be used for all models ending in U.
- FRU with specific models listed and described as 3Dx (where 3D is an example of a unique configuration) should be used for all of these models, unless specific country or region designator is specified.
- A CRU (customer replaceable unit) is identified by a single asterisk (*) or two asterisks (**) in the CRU ID column. An N in the CRU ID column means that the part is not a CRU. A single asterisk (*) means that the part is a Self-service CRU; two asterisks (**) means that the part is an Optional-service CRU.

ThinkPad Notebooks contain the following types of CRUs:

Self-service CRUs

These CRUs unplug or are held by no more than two screws.

Examples of these types of CRUs include an AC adapter, a power cord, a battery, and a hard disk drive. Other Self-service CRUs depending on product design may include a memory, a wireless card, a keyboard, and a palm rest with finger print reader and touchpad.

Optional-service CRUs

These CRUs are isolated parts within the computer that are concealed by an access panel that is typically secured by more than two screws.

Once the access panel is removed, the specific CRU is visible.

- FRUs marked with **OP** are available as options.

Overall

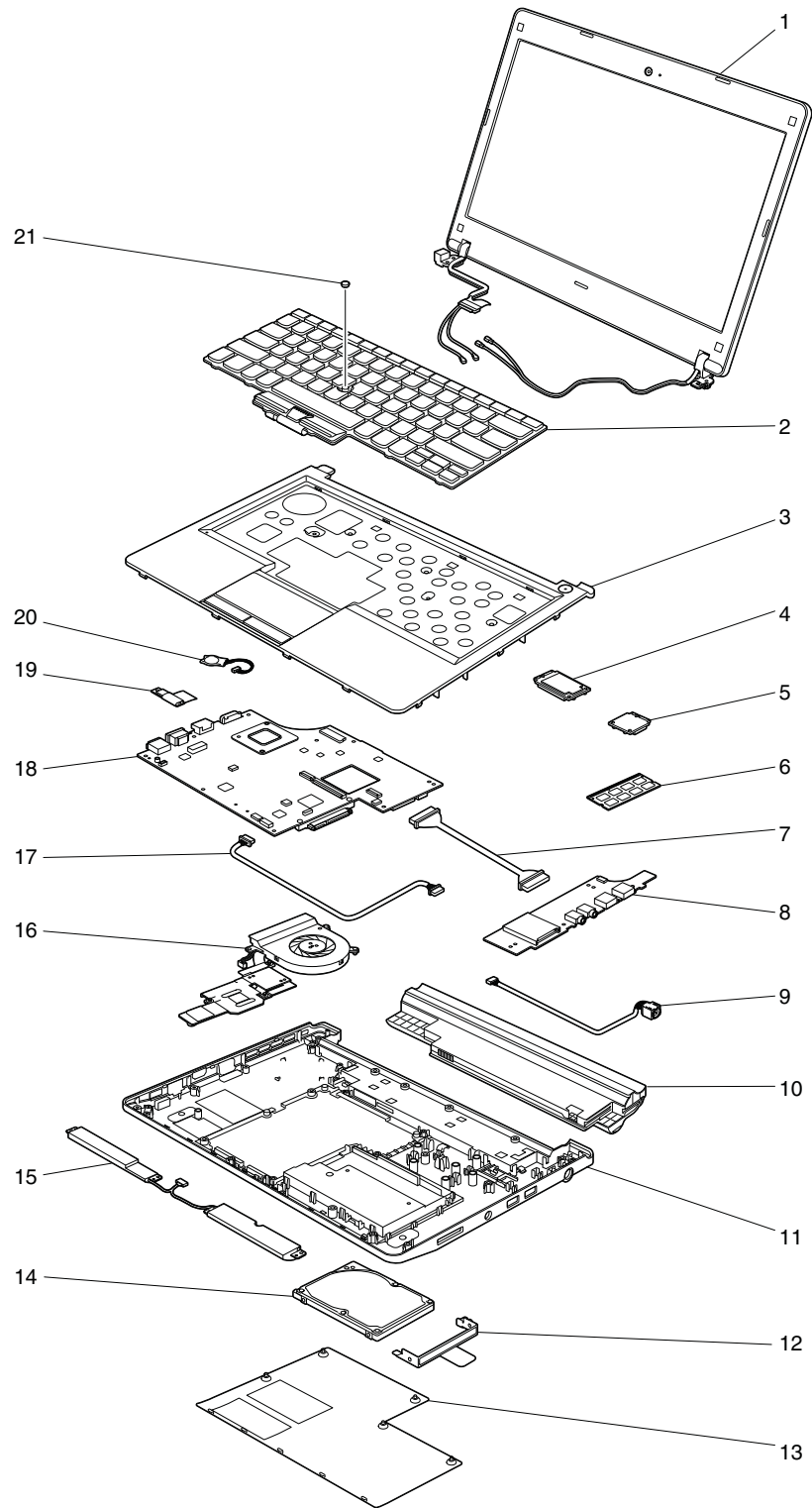

Table 29. Parts list—Overall

No.	FRU (Overall)	FRU no.	CRU ID
1	LCD unit (see “LCD FRUs” on page 126.)		
2	Keyboard (see “Keyboard” on page 129.)		
3	Top case assembly	60Y5520	N
—	Microphone module	60Y5753	N
4	Qualcom Gobi-2000 WWAN <ul style="list-style-type: none"> • 0196-CTO, 22x, 2Ex, 2Gx, 2Jx, 2Lx, 2Qx, 2Tx, 2Ux, 2Vx, 34x, 36x, 38x, 3Ax, 3Cx, 4Ux • 0197-CTO, 22x, 23x 2Qx, 2Tx, 2Ux, 2Vx, 36x, 3Dx, 3Jx, 4Qx, 4Sx, 4Ux, 5Zx, 62x, 64x, 65x, 67x, 68x, 6Kx, 6Mx, 6Px • 0492-CTO, 24x, 28x, 34x, 35x, 36x 	60Y3183	**
4	Leadcore LC5730D WWAN for China mobile <ul style="list-style-type: none"> • 0196-CTO • 0197-CTO • 0492-CTO 	60Y3225	**
4	Huawei EM660 WWAN for China telecom <ul style="list-style-type: none"> • 0196-CTO • 0197-CTO • 0492-CTO 	60Y3227	**
5	ThinkPad 11b/g/n Wireless LAN Mini-PCI Express Adapter II <ul style="list-style-type: none"> • 0196-CTO, 27x, 28x, 29x, 2Cx, 2Hx, 2Jx, 2Mx, 2Rx, 2Zx, 32x, 33x, 34x, 35x, 36x, 37x, 38x, 39x, 3Ax, 3Bx, 3Yx, 3Zx, 42x, 43x, 44x, 45x, 46x, 47x, 48x, 49x, 4Ax, 4Bx • 0197-CTO, 22x, 23x, 24x, 25x, 26x, 27x, 28x, 29x, 2Ax, 2Cx, 2Dx, 2Ex, 2Fx, 2Hx, 2Jx, 2Kx, 2Lx, 2Mx, 2Nx, 2Px, 2Qx, 2Rx, 2Sx, 2Tx, 2Ux, 2Vx, 2Wx, 2Zx, 32x, 33x, 34x, 35x, 36x, 37x, 38x, 39x, 3Ax, 3Bx, 3Cx, 3Dx, 3Ex, 3Fx, 3Gx, 3Hx, 3Jx, 3Kx, 3Lx, 3Mx, 3Nx, 3Px, 3Qx, 3Rx, 3Sx, 3Tx, 3Ux, 3Vx, 3Wx, 3Xx, 3Yx, 3Zx, 42x, 43x, 44x, 45x, 46x, 47x, 48x, 49x, 4Ax, 4Bx, 4Cx, 4Dx, 4Ex, 4Fx, 4Gx, 4Hx, 4Jx, 4Kx, 4Lx, 4Mx, 4Nx, 4Px, 4Qx, 4Rx, 4Sx, 4Tx, 4Ux, 4Vx, 4Wx, 4Xx, 4Yx, 4Zx, 52x, 53x, 54x, 55x, 56x, 57x, 58x, 59x, 5Ax, 5Bx, 5Cx, 5Dx, 5Ex, 5Fx, 5Gx, 5Hx, 5Jx, 5Kx, 5Lx, 5Mx, 5Nx, 5Px, 5Qx, 5Rx, 5Sx, 5Tx, 5Ux, 5Vx, 5Wx, 5Xx, 5Yx, 5Zx, 62x, 63x, 64x, 65x, 66x, 67x, 68x, 69x, 6Ax, 6Bx, 6Cx, 6Dx, 6Ex, 6Gx, 6Hx, 6Jx, 6Kx, 6Lx, 6Mx, 6Nx, 6Px, 6Qx, 6Rx, 6Sx, 6Tx, 6Ux, 6Vx, 6Wx, 6Xx, 6Yx, 6Zx, 72x, 73x • 0492-CTO, 22x, 23x, 26x, 28x, 29x, 2Ax, 2Bx, 2Cx, 2Dx, 2Ex, 2Fx, 2Gx, 2Mx, 2Nx, 2Px, 2Qx, 2Rx, 2Sx, 2Tx, 2Ux, 2Vx, 2Wx, 2Xx, 2Yx, 2Zx, 32x, 33x, 34x, 35x, 36x, 37x, 38x, 39x, 3Ax, 3Bx, 3Cx 	43Y6553	**
5	ThinkPad 11b/g/n Wireless LAN Mini-PCI Express Adapter II <ul style="list-style-type: none"> • 0196-CTO, 27x, 28x, 29x, 2Cx, 2Hx, 2Jx, 2Mx, 2Rx, 2Zx, 32x, 33x, 34x, 35x, 36x, 37x, 38x, 39x, 3Ax, 3Bx, 3Yx, 3Zx, 42x, 43x, 44x, 45x, 46x, 47x, 48x, 49x, 4Ax, 4Bx, • 0197-CTO, 22x, 23x, 24x, 25x, 26x, 27x, 28x, 29x, 2Ax, 2Cx, 2Dx, 2Ex, 2Fx, 2Hx, 2Jx, 2Kx, 2Lx, 2Mx, 2Nx, 2Px, 2Qx, 2Rx, 2Sx, 2Tx, 2Ux, 2Vx, 2Wx, 2Zx, 32x, 33x, 34x, 35x, 36x, 37x, 38x, 39x, 3Ax, 3Bx, 3Cx, 3Dx, 3Ex, 3Fx, 3Gx, 3Hx, 3Jx, 3Kx, 3Lx, 3Mx, 3Nx, 3Px, 3Qx, 3Rx, 3Sx, 3Tx, 3Ux, 3Vx, 3Wx, 3Xx, 3Yx, 3Zx, 42x, 43x, 44x, 45x, 46x, 47x, 48x, 49x, 4Ax, 4Bx, 4Cx, 4Dx, 4Ex, 4Fx, 4Gx, 4Hx, 4Jx, 4Kx, 4Lx, 4Mx, 4Nx, 4Px, 4Qx, 4Rx, 4Sx, 4Tx, 4Ux, 4Vx, 4Wx, 4Xx, 4Yx, 4Zx, 52x, 53x, 54x, 55x, 56x, 57x, 58x, 59x, 5Ax, 5Bx, 5Cx, 5Dx, 5Ex, 5Fx, 5Gx, 5Hx, 5Jx, 5Kx, 5Lx, 5Mx, 5Nx, 5Px, 5Qx, 5Rx, 5Sx, 5Tx, 5Ux, 5Vx, 5Wx, 5Xx, 5Yx, 5Zx, 62x, 63x, 64x, 65x, 66x, 67x, 68x, 69x, 6Ax, 6Bx, 6Cx, 6Dx, 6Ex, 6Gx, 6Hx, 6Jx, 6Kx, 6Lx, 6Mx, 6Nx, 6Px, 6Qx, 6Rx, 6Sx, 6Tx, 6Ux, 6Vx, 6Wx, 6Xx, 6Yx, 6Zx, 72x, 73x • 0492-CTO, 22x, 23x, 26x, 28x, 29x, 2Ax, 2Bx, 2Cx, 2Dx, 2Ex, 2Fx, 2Gx, 2Mx, 2Nx, 2Px, 2Qx, 2Rx, 2Sx, 2Tx, 2Ux, 2Vx, 2Wx, 2Xx, 2Yx, 2Zx, 32x, 33x, 34x, 35x, 36x, 37x, 38x, 39x, 3Ax, 3Bx, 3Cx 	60Y3177	**

Table 29. Parts list—Overall (continued)

No.	FRU (Overall)	FRU no.	CRU ID
5	Intel Centrino Wireless-N 1000 <ul style="list-style-type: none"> • 0196-CTO, 23x, 24x, 25x, 26x, 2Ax, 2Bx, 2Dx, 2Ex, 2Fx, 2Gx, 2Kx, 2Lx, 2Px, 2Qx, 2Tx, 2Ux, 2Vx, 2Wx, 2Xx, 2Yx, 3Cx, 3Dx, 3Ex, 3Fx, 3Gx, 3Hx, 3Jx, 3Kx, 3Lx, 3Mx, 3Nx, 3Px, 3Qx, 3Rx, 3Sx, 3Tx, 3Ux, 4Cx, 4Dx, 4Ex, 4Fx, 4Gx, 4Jx, 4Lx, 4Mx, 4Nx, 4Px, 4Ux, 4Vx, 4Wx, 4Xx, 4Yx, 53x, 54x • 0197-CTO • 0492-CTO, 24x, 25x, 2Hx, 2Jx, 2Kx, 2Lx, 3Dx, 3Ex, 3Fx, 3Gx, 3Hx, 3Jx 	60Y3203	**
5	Intel Centrino Advanced-N + WiMAX 6250, WW SKU <ul style="list-style-type: none"> • 0196-CTO, 22x, 4Qx, 4Rx, 4Sx • 0197-CTO • 0492-CTO 	60Y3195	**
5	Intel Centrino Advanced-N + WiMAX 6250, Russia SKU <ul style="list-style-type: none"> • 0196-CTO • 0197-CTO • 0492-CTO, 3Kx 	60Y3209	**
6	1-GB DDR2-667 SDRAM SO-DIMM (PC2-5300) card <ul style="list-style-type: none"> • 0197-CTO, 25x, 27x, 29x, 2Cx, 2Ex, 2Fx, 2Mx, 32x, 33x, 34x, 35x, 37x, 39x, 3Fx, 3Hx, 3Rx, 3Wx, 43x, 48x, 4Dx, 4Jx, 6Xx, 72x 	40Y8403	**
6	2-GB DDR2-667 SDRAM SO-DIMM (PC2-5300) card <ul style="list-style-type: none"> • 0197-CTO, 22x, 23x, 24x, 25x, 26x, 27x, 28x, 29x, 2Ax, 2Cx, 2Dx, 2Ex, 2Fx, 2Hx, 2Jx, 2Kx, 2Lx, 2Mx, 2Nx, 2Px, 2Qx, 2Rx, 2Sx, 2Tx, 2Ux, 2Vx, 2Wx, 2Zx, 32x, 36x, 38x, 39x, 3Ax, 3Bx, 3Cx, 3Dx, 3Ex, 3Gx, 3Jx, 3Kx, 3Lx, 3Mx, 3Nx, 3Px, 3Qx, 3Sx, 3Tx, 3Ux, 3Vx, 3Xx, 3Yx, 3Zx, 42x, 44x, 45x, 46x, 47x, 49x, 4Ax, 4Bx, 4Cx, 4Ex, 4Fx, 4Gx, 4Hx, 4Kx, 4Lx, 4Mx, 4Nx, 4Px, 4Qx, 4Rx, 4Sx, 4Tx, 4Ux, 4Vx, 4Wx, 4Xx, 4Yx, 4Zx, 52x, 53x, 54x, 55x, 56x, 57x, 58x, 59x, 5Ax, 5Bx, 5Cx, 5Dx, 5Ex, 5Fx, 5Gx, 5Hx, 5Jx, 5Kx, 5Lx, 5Mx, 5Nx, 5Px, 5Qx, 5Rx, 5Sx, 5Tx, 5Ux, 5Vx, 5Wx, 5Xx, 5Yx, 5Zx, 62x, 63x, 64x, 65x, 66x, 67x, 68x, 69x, 6Ax, 6Bx, 6Cx, 6Dx, 6Ex, 6Gx, 6Hx, 6Jx, 6Kx, 6Lx, 6Mx, 6Nx, 6Px, 6Qx, 6Rx, 6Sx, 6Tx, 6Ux, 6Vx, 6Wx, 6Yx, 6Zx, 72x, 73x 	40Y8404	**
6	1-GB DDR3-1066 SDRAM SO-DIMM (PC3-8500) card <ul style="list-style-type: none"> • 0196-CTO, 24x, 2Bx, 36x, 39x, 3Dx, 3Qx, 4Ex, 4Fx, 4Yx • 0492-CTO, 25x, 26x, 2Hx, 36x, 3Bx 	55Y3712	**
6	2-GB DDR3-1066 SDRAM SO-DIMM (PC3-8500) card <ul style="list-style-type: none"> • 0196-CTO, 22x, 23x, 24x, 25x, 26x, 27x, 28x, 29x, 2Ax, 2Bx, 2Cx, 2Dx, 2Ex, 2Fx, 2Gx, 2Hx, 2Jx, 2Kx, 2Lx, 2Mx, 2Px, 2Qx, 2Rx, 2Tx, 2Ux, 2Vx, 2Wx, 2Xx, 2Yx, 2Zx, 32x, 33x, 34x, 35x, 36x, 37x, 38x, 3Ax, 3Bx, 3Cx, 3Ex, 3Fx, 3Gx, 3Hx, 3Jx, 3Kx, 3Lx, 3Mx, 3Nx, 3Px, 3Rx, 3Sx, 3Tx, 3Ux, 3Yx, 3Zx, 42x, 43x, 44x, 45x, 46x, 47x, 48x, 49x, 4Ax, 4Bx, 4Cx, 4Dx, 4Ex, 4Gx, 4Jx, 4Lx, 4Mx, 4Nx, 4Px, 4Qx, 4Rx, 4Sx, 4Ux, 4Vx, 4Wx, 4Xx, 53x, 54x • 0492-CTO, 22x, 23x, 24x, 25x, 26x, 28x, 29x, 2Ax, 2Bx, 2Cx, 2Dx, 2Ex, 2Fx, 2Gx, 2Jx, 2Kx, 2Lx, 2Mx, 2Nx, 2Px, 2Qx, 2Rx, 2Sx, 2Tx, 2Ux, 2Vx, 2Wx, 2Xx, 2Yx, 2Zx, 32x, 33x, 34x, 35x, 37x, 38x, 39x, 3Ax, 3Cx, 3Dx, 3Ex, 3Fx, 3Gx, 3Hx, 3Jx, 3Kx, 52x 	55Y3713	**
7	I/O cable	45M2905	N
8	Function board assembly	63Y2127	N
9	DC-in cable	45M2901	N

Table 29. Parts list—Overall (continued)

No.	FRU (Overall)	FRU no.	CRU ID
10	Battery pack, Li-ion (4 cell) 73 <ul style="list-style-type: none"> • 0196-CTO, 23x, 27x, 2Cx, 2Ex, 2Fx, 2Hx, 2Jx, 2Ux, 2Xx, 3Jx, 3Nx, 3Px, 3Rx, 3Sx, 3Tx, 3Ux, 47x, 48x, 49x, 4Ax, 4Bx, 4Cx, 4Dx, 4Ex, 4Gx, 4Jx, 4Lx, 4Mx, 4Nx, 4Px, 4Yx • 0197-CTO, 27x, 29x, 2Mx, 2Rx, 2Sx, 2Tx, 2Ux, 2Vx, 3Tx, 3Ux, 3Vx, 3Wx, 3Xx, 3Yx, 3Zx, 42x, 43x, 44x, 45x, 46x, 47x, 48x, 49x, 4Ax, 4Bx, 4Cx, 4Dx, 4Ex, 4Fx, 4Gx, 4Hx, 4Jx, 4Kx, 4Lx, 4Mx, 4Nx, 4Px, 4Qx, 4Sx, 4Ux, 4Wx, 4Xx, 4Yx, 4Zx, 52x, 53x, 54x, 55x, 56x, 57x, 58x, 59x, 5Ax, 5Bx, 5Cx, 5Dx, 5Ex, 5Fx, 5Gx, 5Hx, 5Jx, 5Kx, 5Lx, 5Mx, 5Nx, 5Px, 5Qx, 5Rx, 5Sx, 5Tx, 5Ux, 5Vx, 5Wx, 6Hx, 6Jx, 6Kx, 6Lx, 6Mx, 6Nx, 6Xx • 0492-CTO, 22x, 26x, 28x, 29x, 2Ax, 2Bx, 2Cx, 2Fx, 2Gx, 2Jx, 2Kx, 2Lx, 2Mx, 2Nx, 2Px, 2Qx, 2Rx, 2Sx, 2Tx, 2Ux, 2Vx, 2Wx, 2Xx, 2Yx, 2Zx, 32x, 36x, 37x, 38x, 39x, 3Ax, 3Bx, 3Cx, 3Kx 	42T4805	*
10	Battery pack, Li-ion (4 cell) 73 <ul style="list-style-type: none"> • 0196-CTO, 23x, 27x, 2Cx, 2Ex, 2Fx, 2Hx, 2Jx, 2Ux, 2Xx, 3Jx, 3Nx, 3Px, 3Rx, 3Sx, 3Tx, 3Ux, 47x, 48x, 49x, 4Ax, 4Bx, 4Cx, 4Dx, 4Ex, 4Gx, 4Jx, 4Lx, 4Mx, 4Nx, 4Px, 4Yx • 0197-CTO, 27x, 29x, 2Mx, 2Rx, 2Sx, 2Tx, 2Ux, 2Vx, 3Tx, 3Ux, 3Vx, 3Wx, 3Xx, 3Yx, 3Zx, 42x, 43x, 44x, 45x, 46x, 47x, 48x, 49x, 4Ax, 4Bx, 4Cx, 4Dx, 4Ex, 4Fx, 4Gx, 4Hx, 4Jx, 4Kx, 4Lx, 4Mx, 4Nx, 4Px, 4Qx, 4Sx, 4Ux, 4Wx, 4Xx, 4Yx, 4Zx, 52x, 53x, 54x, 55x, 56x, 57x, 58x, 59x, 5Ax, 5Bx, 5Cx, 5Dx, 5Ex, 5Fx, 5Gx, 5Hx, 5Jx, 5Kx, 5Lx, 5Mx, 5Nx, 5Px, 5Qx, 5Rx, 5Sx, 5Tx, 5Ux, 5Vx, 5Wx, 6Hx, 6Jx, 6Kx, 6Lx, 6Mx, 6Nx, 6Xx • 0492-CTO, 22x, 26x, 28x, 29x, 2Ax, 2Bx, 2Cx, 2Fx, 2Gx, 2Jx, 2Kx, 2Lx, 2Mx, 2Nx, 2Px, 2Qx, 2Rx, 2Sx, 2Tx, 2Ux, 2Vx, 2Wx, 2Xx, 2Yx, 2Zx, 32x, 36x, 37x, 38x, 39x, 3Ax, 3Bx, 3Cx, 3Kx 	42T4807	*
10	Battery pack, Li-ion (6 cell) 73+ <ul style="list-style-type: none"> • 0196-CTO, 22x, 24x, 25x, 26x, 28x, 29x, 2Ax, 2Bx, 2Dx, 2Gx, 2Kx, 2Lx, 2Mx, 2Px, 2Qx, 2Rx, 2Tx, 2Vx, 2Wx, 2Yx, 2Zx, 32x, 33x, 34x, 35x, 36x, 37x, 38x, 39x, 3Ax, 3Bx, 3Cx, 3Dx, 3Ex, 3Fx, 3Gx, 3Hx, 3Kx, 3Lx, 3Mx, 3Qx, 3Yx, 3Zx, 42x, 43x, 44x, 45x, 46x, 4Fx, 4Qx, 4Rx, 4Sx, 4Ux, 4Vx, 4Wx, 4Xx, 53x, 54x • 0197-CTO, 23x, 24x, 25x, 26x, 28x, 2Ax, 2Cx, 2Dx, 2Ex, 2Fx, 2Hx, 2Jx, 2Kx, 2Lx, 2Nx, 2Px, 2Qx, 2Wx, 2Zx, 32x, 33x, 34x, 35x, 36x, 37x, 38x, 39x, 3Ax, 3Bx, 3Cx, 3Dx, 3Ex, 3Fx, 3Gx, 3Hx, 3Jx, 3Kx, 3Lx, 3Mx, 3Nx, 3Px, 3Qx, 3Rx, 3Sx, 4Rx, 4Tx, 4Vx, 5Xx, 5Yx, 5Zx, 62x, 63x, 64x, 65x, 66x, 67x, 68x, 69x, 6Ax, 6Bx, 6Cx, 6Dx, 6Ex, 6Gx, 6Px, 6Qx, 6Rx, 6Sx, 6Tx, 6Ux, 6Vx, 6Wx, 6Yx, 6Zx, 72x, 73x • 0492-CTO, 23x, 24x, 25x, 2Dx, 2Ex, 2Hx, 33x, 34x, 35x, 3Dx, 3Ex, 3Fx, 3Gx, 3Hx, 3Jx 	42T4813	*
10	Battery pack, Li-ion (6 cell) 73+ <ul style="list-style-type: none"> • 0196-CTO, 22x, 24x, 25x, 26x, 28x, 29x, 2Ax, 2Bx, 2Dx, 2Gx, 2Kx, 2Lx, 2Mx, 2Px, 2Qx, 2Rx, 2Tx, 2Vx, 2Wx, 2Yx, 2Zx, 32x, 33x, 34x, 35x, 36x, 37x, 38x, 39x, 3Ax, 3Bx, 3Cx, 3Dx, 3Ex, 3Fx, 3Gx, 3Hx, 3Kx, 3Lx, 3Mx, 3Qx, 3Yx, 3Zx, 42x, 43x, 44x, 45x, 46x, 4Fx, 4Qx, 4Rx, 4Sx, 4Ux, 4Vx, 4Wx, 4Xx, 53x, 54x • 0197-CTO, 23x, 24x, 25x, 26x, 28x, 2Ax, 2Cx, 2Dx, 2Ex, 2Fx, 2Hx, 2Jx, 2Kx, 2Lx, 2Nx, 2Px, 2Qx, 2Wx, 2Zx, 32x, 33x, 34x, 35x, 36x, 37x, 38x, 39x, 3Ax, 3Bx, 3Cx, 3Dx, 3Ex, 3Fx, 3Gx, 3Hx, 3Jx, 3Kx, 3Lx, 3Mx, 3Nx, 3Px, 3Qx, 3Rx, 3Sx, 4Rx, 4Tx, 4Vx, 5Xx, 5Yx, 5Zx, 62x, 63x, 64x, 65x, 66x, 67x, 68x, 69x, 6Ax, 6Bx, 6Cx, 6Dx, 6Ex, 6Gx, 6Px, 6Qx, 6Rx, 6Sx, 6Tx, 6Ux, 6Vx, 6Wx, 6Yx, 6Zx, 72x, 73x • 0492-CTO, 23x, 24x, 25x, 2Dx, 2Ex, 2Hx, 33x, 34x, 35x, 3Dx, 3Ex, 3Fx, 3Gx, 3Hx, 3Jx 	42T4815	*
11	Base cover assembly for 0196	60Y5528	N
11	Base cover assembly for 0197	60Y5530	N
11	Base cover assembly for 0492	60Y5529	N
12	HDD cover bracket	60Y5532	N
13	HDD slot cover	60Y5517	N

Table 29. Parts list—Overall (continued)

No.	FRU (Overall)	FRU no.	CRU ID
14	SATA hard disk drive, 160 GB, 5,400 rpm <ul style="list-style-type: none"> • 0196-CTO, 3Cx, 3Ux, 4Fx • 0197-CTO, 2Mx, 2Nx, 2Ux, 3Bx, 3Hx • 0492-CTO, 2Hx 	60Y4755	**
14	SATA hard disk drive, 160 GB, 5,400 rpm <ul style="list-style-type: none"> • 0196-CTO, 3Cx, 3Ux, 4Fx • 0197-CTO, 2Mx, 2Nx, 2Ux, 3Bx, 3Hx • 0492-CTO, 2Hx 	60Y4747	**
14	SATA hard disk drive, 160 GB, 5,400 rpm <ul style="list-style-type: none"> • 0196-CTO, 3Cx, 3Ux, 4Fx • 0197-CTO, 2Mx, 2Nx, 2Ux, 3Bx, 3Hx • 0492-CTO, 2Hx 	60Y4763	**
14	SATA hard disk drive, 250 GB, 5,400 rpm <ul style="list-style-type: none"> • 0196-CTO, 23x, 27x, 29x, 2Xx, 3Dx, 3Hx, 3Jx, 3Kx, 3Lx, 3Mx, 3Qx, 44x, 48x, 49x, 4Ax, 4Dx, 4Ex, 4Jx • 0197-CTO, 27x, 28x, 29x, 2Kx, 2Px, 2Rx, 2Vx, 2Zx, 34x, 35x, 36x, 37x, 3Cx, 3Dx, 3Ex, 3Gx, 3Jx, 3Kx, 3Lx, 3Tx, 3Ux, 3Yx, 3Zx, 45x, 46x, 4Ax, 4Bx, 4Fx, 4Gx, 4Lx, 4Mx, 4Xx, 4Yx, 53x, 54x, 57x, 58x, 5Bx, 5Cx, 5Fx, 5Gx, 5Kx, 5Lx, 5Px, 5Qx, 5Tx, 5Ux, 6Zx, 72x • 0492-CTO, 22x, 2Fx, 2Px, 2Wx, 32x, 33x, 35x, 36x, 39x, 3Bx, 3Cx, 3Kx 	60Y4757	**
14	SATA hard disk drive, 250 GB, 5,400 rpm <ul style="list-style-type: none"> • 0196-CTO, 23x, 27x, 29x, 2Xx, 3Dx, 3Hx, 3Jx, 3Kx, 3Lx, 3Mx, 3Qx, 44x, 48x, 49x, 4Ax, 4Dx, 4Ex, 4Jx • 0197-CTO, 27x, 28x, 29x, 2Kx, 2Px, 2Rx, 2Vx, 2Zx, 34x, 35x, 36x, 37x, 3Cx, 3Dx, 3Ex, 3Gx, 3Jx, 3Kx, 3Lx, 3Tx, 3Ux, 3Yx, 3Zx, 45x, 46x, 4Ax, 4Bx, 4Fx, 4Gx, 4Lx, 4Mx, 4Xx, 4Yx, 53x, 54x, 57x, 58x, 5Bx, 5Cx, 5Fx, 5Gx, 5Kx, 5Lx, 5Px, 5Qx, 5Tx, 5Ux, 6Zx, 72x • 0492-CTO, 22x, 2Fx, 2Px, 2Wx, 32x, 33x, 35x, 36x, 39x, 3Bx, 3Cx, 3Kx 	60Y4749	**
14	SATA hard disk drive, 250 GB, 5,400 rpm <ul style="list-style-type: none"> • 0196-CTO, 23x, 27x, 29x, 2Xx, 3Dx, 3Hx, 3Jx, 3Kx, 3Lx, 3Mx, 3Qx, 44x, 48x, 49x, 4Ax, 4Dx, 4Ex, 4Jx • 0197-CTO, 27x, 28x, 29x, 2Kx, 2Px, 2Rx, 2Vx, 2Zx, 34x, 35x, 36x, 37x, 3Cx, 3Dx, 3Ex, 3Gx, 3Jx, 3Kx, 3Lx, 3Tx, 3Ux, 3Yx, 3Zx, 45x, 46x, 4Ax, 4Bx, 4Fx, 4Gx, 4Lx, 4Mx, 4Xx, 4Yx, 53x, 54x, 57x, 58x, 5Bx, 5Cx, 5Fx, 5Gx, 5Kx, 5Lx, 5Px, 5Qx, 5Tx, 5Ux, 6Zx, 72x • 0492-CTO, 22x, 2Fx, 2Px, 2Wx, 32x, 33x, 35x, 36x, 39x, 3Bx, 3Cx, 3Kx 	60Y4765	**
14	SATA hard disk drive, 320 GB, 5,400 rpm <ul style="list-style-type: none"> • 0196-CTO, 22x, 28x, 2Ax, 2Bx, 2Cx, 2Ex, 2Fx, 2Hx, 2Jx, 2Lx, 2Mx, 2Px, 2Qx, 2Rx, 2Tx, 2Ux, 2Zx, 32x, 33x, 34x, 35x, 36x, 3Bx, 3Ex, 3Fx, 3Gx, 3Nx, 3Px, 3Rx, 3Sx, 3Tx, 3Yx, 3Zx, 42x, 43x, 47x, 4Bx, 4Cx, 4Lx, 4Nx, 4Qx, 4Rx, 4Sx, 4Ux, 4Vx, 4Wx, 4Xx, 53x, 54x • 0197-CTO, 2Fx, 2Hx, 2Jx, 2Lx, 2Qx, 2Sx, 2Tx, 2Wx, 32x, 39x, 3Ax, 3Fx, 3Mx, 3Nx, 3Px, 3Qx, 3Rx, 3Sx, 3Vx, 42x, 47x, 4Cx, 4Hx, 4Nx, 4Sx, 4Ux, 4Wx, 4Zx, 52x, 55x, 56x, 59x, 5Ax, 5Dx, 5Ex, 5Hx, 5Jx, 5Mx, 5Nx, 5Rx, 5Sx, 5Vx, 5Wx, 5Xx, 5Yx, 5Zx, 62x, 64x, 65x, 67x, 68x, 6Ax, 6Bx, 6Cx, 6Dx, 6Ex, 6Gx, 6Hx, 6Jx, 6Kx, 6Lx, 6Mx, 6Nx, 6Rx, 6Sx, 6Tx, 6Ux, 6Vx, 6Wx, 6Xx, 6Yx • 0492-CTO, 23x, 24x, 26x, 28x, 29x, 2Ax, 2Bx, 2Cx, 2Gx, 2Lx, 2Qx, 2Tx, 2Ux, 2Vx, 2Xx, 2Yx, 2Zx, 34x, 37x, 3Dx, 3Ex, 3Fx, 3Gx, 3Hx, 3Jx 	60Y4759	**

Table 29. Parts list—Overall (continued)

No.	FRU (Overall)	FRU no.	CRU ID
14	SATA hard disk drive, 320 GB, 5,400 rpm <ul style="list-style-type: none"> • 0196-CTO, 22x, 28x, 2Ax, 2Bx, 2Cx, 2Ex, 2Fx, 2Hx, 2Jx, 2Lx, 2Mx, 2Px, 2Qx, 2Rx, 2Tx, 2Ux, 2Zx, 32x, 33x, 34x, 35x, 36x, 3Bx, 3Ex, 3Fx, 3Gx, 3Nx, 3Px, 3Rx, 3Sx, 3Tx, 3Yx, 3Zx, 42x, 43x, 47x, 4Bx, 4Cx, 4Lx, 4Nx, 4Qx, 4Rx, 4Sx, 4Ux, 4Vx, 4Wx, 4Xx, 53x, 54x • 0197-CTO, 2Fx, 2Hx, 2Jx, 2Lx, 2Qx, 2Sx, 2Tx, 2Wx, 32x, 39x, 3Ax, 3Fx, 3Mx, 3Nx, 3Px, 3Qx, 3Rx, 3Sx, 3Vx, 42x, 47x, 4Cx, 4Hx, 4Nx, 4Sx, 4Ux, 4Wx, 4Zx, 52x, 55x, 56x, 59x, 5Ax, 5Dx, 5Ex, 5Hx, 5Jx, 5Mx, 5Nx, 5Rx, 5Sx, 5Vx, 5Wx, 5Xx, 5Yx, 5Zx, 62x, 64x, 65x, 67x, 68x, 6Ax, 6Bx, 6Cx, 6Dx, 6Ex, 6Gx, 6Hx, 6Jx, 6Kx, 6Lx, 6Mx, 6Nx, 6Rx, 6Sx, 6Tx, 6Ux, 6Vx, 6Wx, 6Xx, 6Yx • 0492-CTO, 23x, 24x, 26x, 28x, 29x, 2Ax, 2Bx, 2Cx, 2Gx, 2Lx, 2Qx, 2Tx, 2Ux, 2Vx, 2Xx, 2Yx, 2Zx, 34x, 37x, 3Dx, 3Ex, 3Fx, 3Gx, 3Hx, 3Jx 	60Y4751	**
14	SATA hard disk drive, 320 GB, 5,400 rpm <ul style="list-style-type: none"> • 0196-CTO, 22x, 28x, 2Ax, 2Bx, 2Cx, 2Ex, 2Fx, 2Hx, 2Jx, 2Lx, 2Mx, 2Px, 2Qx, 2Rx, 2Tx, 2Ux, 2Zx, 32x, 33x, 34x, 35x, 36x, 3Bx, 3Ex, 3Fx, 3Gx, 3Nx, 3Px, 3Rx, 3Sx, 3Tx, 3Yx, 3Zx, 42x, 43x, 47x, 4Bx, 4Cx, 4Lx, 4Nx, 4Qx, 4Rx, 4Sx, 4Ux, 4Vx, 4Wx, 4Xx, 53x, 54x • 0197-CTO, 2Fx, 2Hx, 2Jx, 2Lx, 2Qx, 2Sx, 2Tx, 2Wx, 32x, 39x, 3Ax, 3Fx, 3Mx, 3Nx, 3Px, 3Qx, 3Rx, 3Sx, 3Vx, 42x, 47x, 4Cx, 4Hx, 4Nx, 4Sx, 4Ux, 4Wx, 4Zx, 52x, 55x, 56x, 59x, 5Ax, 5Dx, 5Ex, 5Hx, 5Jx, 5Mx, 5Nx, 5Rx, 5Sx, 5Vx, 5Wx, 5Xx, 5Yx, 5Zx, 62x, 64x, 65x, 67x, 68x, 6Ax, 6Bx, 6Cx, 6Dx, 6Ex, 6Gx, 6Hx, 6Jx, 6Kx, 6Lx, 6Mx, 6Nx, 6Rx, 6Sx, 6Tx, 6Ux, 6Vx, 6Wx, 6Xx, 6Yx • 0492-CTO, 23x, 24x, 26x, 28x, 29x, 2Ax, 2Bx, 2Cx, 2Gx, 2Lx, 2Qx, 2Tx, 2Ux, 2Vx, 2Xx, 2Yx, 2Zx, 34x, 37x, 3Dx, 3Ex, 3Fx, 3Gx, 3Hx, 3Jx 	60Y4767	**
14	SATA hard disk drive, 500 GB, 5,400 rpm <ul style="list-style-type: none"> • 0196-CTO, 2Dx, 2Gx, 2Kx, 2Vx, 2Wx, 2Yx, 38x, 39x, 3Ax, 4Gx, 4Mx, 4Px, 4Yx • 0197-CTO, 25x, 26x, 38x, 3Wx, 3Xx, 43x, 44x, 48x, 49x, 4Dx, 4Ex, 4Jx, 4Kx, 4Px, 4Qx, 4Rx, 4Tx, 4Vx, 6Px, 6Qx • 0492-CTO, 25x, 2Dx, 2Ex, 2Jx, 2Kx, 2Mx, 2Nx, 2Rx, 2Sx, 38x, 3Ax 	60Y4761	**
14	SATA hard disk drive, 500 GB, 5,400 rpm <ul style="list-style-type: none"> • 0196-CTO, 2Dx, 2Gx, 2Kx, 2Vx, 2Wx, 2Yx, 38x, 39x, 3Ax, 4Gx, 4Mx, 4Px, 4Yx • 0197-CTO, 25x, 26x, 38x, 3Wx, 3Xx, 43x, 44x, 48x, 49x, 4Dx, 4Ex, 4Jx, 4Kx, 4Px, 4Qx, 4Rx, 4Tx, 4Vx, 6Px, 6Qx • 0492-CTO, 25x, 2Dx, 2Ex, 2Jx, 2Kx, 2Mx, 2Nx, 2Rx, 2Sx, 38x, 3Ax 	60Y4753	**
14	SATA hard disk drive, 500 GB, 5,400 rpm <ul style="list-style-type: none"> • 0196-CTO, 2Dx, 2Gx, 2Kx, 2Vx, 2Wx, 2Yx, 38x, 39x, 3Ax, 4Gx, 4Mx, 4Px, 4Yx • 0197-CTO, 25x, 26x, 38x, 3Wx, 3Xx, 43x, 44x, 48x, 49x, 4Dx, 4Ex, 4Jx, 4Kx, 4Px, 4Qx, 4Rx, 4Tx, 4Vx, 6Px, 6Qx • 0492-CTO, 25x, 2Dx, 2Ex, 2Jx, 2Kx, 2Mx, 2Nx, 2Rx, 2Sx, 38x, 3Ax 	60Y4769	**
14	SATA hard disk drive, 250 GB, 7,200 rpm <ul style="list-style-type: none"> • 0196-CTO • 0197-CTO • 0492-CTO 	60Y4775	**
14	SATA hard disk drive, 250 GB, 7,200 rpm <ul style="list-style-type: none"> • 0196-CTO • 0197-CTO • 0492-CTO 	60Y4771	**
14	SATA hard disk drive, 250 GB, 7,200 rpm <ul style="list-style-type: none"> • 0196-CTO • 0197-CTO • 0492-CTO 	60Y4781	**
14	SATA hard disk drive, 320 GB, 7,200 rpm <ul style="list-style-type: none"> • 0196-CTO, 24x, 25x, 26x, 37x, 45x, 46x • 0197-CTO, 23x, 24x, 2Ax, 2Cx, 2Dx, 2Ex, 33x, 63x, 66x, 69x, 73x • 0492-CTO 	60Y4777	**

Table 29. Parts list—Overall (continued)

No.	FRU (Overall)	FRU no.	CRU ID
14	SATA hard disk drive, 320 GB, 7,200 rpm <ul style="list-style-type: none"> • 0196-CTO, 24x, 25x, 26x, 37x, 45x, 46x • 0197-CTO, 23x, 24x, 2Ax, 2Cx, 2Dx, 2Ex, 33x, 63x, 66x, 69x, 73x • 0492-CTO 	60Y4773	**
14	SATA hard disk drive, 320 GB, 7,200 rpm <ul style="list-style-type: none"> • 0196-CTO, 24x, 25x, 26x, 37x, 45x, 46x • 0197-CTO, 23x, 24x, 2Ax, 2Cx, 2Dx, 2Ex, 33x, 63x, 66x, 69x, 73x • 0492-CTO 	45N7281	**
14	SATA hard disk drive, 500 GB, 7,200 rpm <ul style="list-style-type: none"> • 0196-CTO • 0197-CTO • 0492-CTO 	60Y4779	**
14	SATA hard disk drive, 500 GB, 7,200 rpm <ul style="list-style-type: none"> • 0196-CTO • 0197-CTO • 0492-CTO 	60Y4785	**
15	Speaker assembly	60Y5754	N
16	Thermal module with fan, for Intel chipset <ul style="list-style-type: none"> • 0196-all • 0492-all 	60Y5518	N
16	Thermal module with fan, for AMD chipset <ul style="list-style-type: none"> • 0197-all 	60Y5519	N
17	Audio cable	45M2904	N
18	System board assembly, Intel Core 2 Duo processor SU7300 <ul style="list-style-type: none"> • 0196-CTO, 22x, 23x, 24x, 25x, 26x, 27x, 28x, 29x, 2Ax, 2Bx, 2Cx, 2Dx, 2Ex, 2Fx, 2Gx, 2Hx, 2Jx, 2Kx, 2Lx, 2Mx, 2Px, 2Qx, 2Rx, 2Tx, 2Ux, 2Vx, 2Wx, 2Xx, 2Yx, 2Zx, 32x, 33x, 34x, 35x, 36x, 37x, 38x, 39x, 3Ax, 3Bx, 3Cx, 3Dx, 3Ex, 3Fx, 3Gx, 3Hx, 3Jx, 3Kx, 3Lx, 3Mx, 3Nx, 3Px, 3Qx, 3Rx, 3Sx, 3Tx, 3Ux, 3Yx, 3Zx, 42x, 43x, 44x, 45x, 46x, 47x, 48x, 49x • 0492-CTO, 22x, 23x, 24x, 25x, 26x, 28x, 29x, 2Ax, 2Bx, 2Cx, 2Dx, 2Ex, 2Fx, 2Gx, 2Jx, 2Kx, 2Lx, 2Mx, 2Nx, 2Px, 2Qx, 2Rx, 2Sx, 2Tx, 2Ux, 2Vx, 3Gx, 3Hx, 3Jx 	63Y2042	N
18	System board assembly, Intel Core 2 Solo processor Retail (SU4100) <ul style="list-style-type: none"> • 0196-CTO, 4Ax, 4Bx, 4Cx, 4Dx, 4Ex, 4Fx, 4Gx, 4Jx, 4Lx, 4Mx, 4Nx, 4Px, 4Qx, 4Rx, 4Sx, 4Ux, 4Vx, 4Wx, 4Xx, 4Yx, 53x, 54x • 0492-CTO, 2Hx, 2Wx, 2Xx, 2Yx, 2Zx, 32x, 33x, 34x, 35x, 36x, 37x, 38x, 39x, 3Ax, 3Bx, 3Cx, 3Dx, 3Ex, 3Fx, 3Kx 	60Y5701	N
18	System board assembly, Intel Celeron processor SU2300 <ul style="list-style-type: none"> • 0196-CTO • 0492-CTO 	63Y2104	N
18	System board assembly, AMD Turion Neo X2 Dual-Core L625 <ul style="list-style-type: none"> • 0197-CTO, 23x, 24x, 25x, 2Ex, 2Jx, 2Qx, 2Sx, 2Tx, 2Vx, 2Wx, 32x, 33x, 35x, 36x, 38x, 3Ax, 3Bx, 3Cx, 3Dx, 3Ex, 3Fx, 3Mx, 3Nx, 3Px, 3Qx, 3Rx, 3Sx, 3Yx, 3Zx, 42x, 43x, 44x, 4Ax, 4Bx, 4Cx, 4Dx, 4Ex, 4Lx, 4Mx, 4Nx, 4Px, 4Qx, 4Rx, 4Tx, 4Vx, 4Xx, 4Yx, 4Zx, 52x, 53x, 54x, 55x, 56x, 5Fx, 5Gx, 5Hx, 5Jx, 5Kx, 5Lx, 5Mx, 5Nx, 5Yx, 5Zx, 62x, 63x, 64x, 65x, 66x, 67x, 68x, 69x, 6Ax, 6Px, 6Qx, 6Vx, 6Wx, 6Xx, 6Yx 	60Y5703	N
18	System board assembly, AMD Athlon Neo X2 Dual-Core L325 <ul style="list-style-type: none"> • 0197-CTO, 26x, 27x, 28x, 29x, 2Ax, 2Cx, 2Dx, 2Fx, 2Hx, 2Kx, 2Lx, 2Mx, 2Nx, 2Px, 2Rx, 2Ux, 2Zx, 34x, 37x, 39x, 3Gx, 3Hx, 3Jx, 3Kx, 3Lx, 3Tx, 3Ux, 3Vx, 3Wx, 3Xx, 45x, 46x, 47x, 48x, 49x, 4Fx, 4Gx, 4Hx, 4Jx, 4Kx, 4Sx, 4Ux, 4Wx, 57x, 58x, 59x, 5Ax, 5Bx, 5Cx, 5Dx, 5Ex, 5Px, 5Qx, 5Rx, 5Sx, 5Tx, 5Ux, 5Vx, 5Wx, 5Xx, 6Bx, 6Cx, 6Dx, 6Ex, 6Gx, 6Hx, 6Jx, 6Kx, 6Lx, 6Mx, 6Nx, 6Rx, 6Sx, 6Tx, 6Ux, 6Zx, 72x, 73x 	60Y5705	N

Table 29. Parts list—Overall (continued)

No.	FRU (Overall)	FRU no.	CRU ID
18	System board assembly, AMD Athlon Neo X2 Single-Core MV-40 • 0197-CTO	60Y5707	N
19	Bluetooth daughter card (BDC-2.1) • 0196-CTO, 22x, 23x, 24x, 25x, 26x, 27x, 28x, 29x, 2Ax, 2Bx, 2Cx, 2Dx, 2Ex, 2Fx, 2Gx, 2Hx, 2Jx, 2Kx, 2Lx, 2Mx, 2Px, 2Qx, 2Rx, 2Tx, 2Ux, 2Vx, 2Wx, 2Xx, 2Yx, 2Zx, 32x, 33x, 34x, 35x, 36x, 37x, 38x, 39x, 3Ax, 3Bx, 3Cx, 3Dx, 3Ex, 3Fx, 3Gx, 3Jx, 3Kx, 3Lx, 3Mx, 3Nx, 3Px, 3Qx, 3Rx, 3Sx, 3Tx, 3Yx, 3Zx, 42x, 43x, 45x, 46x, 47x, 48x, 49x, 4Ax, 4Bx, 4Cx, 4Ex, 4Mx, 4Qx, 4Rx, 4Sx, 4Ux, 4Vx, 4Wx, 4Xx • 0197-CTO, 23x, 24x, 2Ax, 2Cx, 2Dx, 2Ex, 2Fx, 2Hx, 2Jx, 2Kx, 2Lx, 2Px, 2Qx, 2Rx, 2Sx, 2Tx, 2Ux, 2Vx, 2Wx, 2Zx, 32x, 33x, 34x, 35x, 36x, 37x, 38x, 39x, 3Ax, 3Bx, 3Cx, 3Dx, 3Ex, 3Gx, 3Hx, 3Jx, 3Kx, 3Mx, 3Nx, 3Px, 3Qx, 3Rx, 3Sx, 3Xx, 44x, 49x, 4Ex, 4Kx, 4Qx, 4Rx, 4Sx, 4Tx, 4Ux, 4Vx, 4Wx, 4Xx, 4Yx, 4Zx, 52x, 53x, 54x, 55x, 56x, 57x, 58x, 59x, 5Ax, 5Bx, 5Cx, 5Dx, 5Ex, 5Fx, 5Gx, 5Hx, 5Jx, 5Kx, 5Lx, 5Mx, 5Nx, 5Px, 5Qx, 5Rx, 5Sx, 5Tx, 5Ux, 5Vx, 5Wx, 5Xx, 5Yx, 5Zx, 62x, 63x, 64x, 65x, 66x, 67x, 68x, 69x, 6Ax, 6Ex, 6Gx, 6Hx, 6Jx, 6Kx, 6Lx, 6Mx, 6Nx, 6Px, 6Qx, 6Rx, 6Sx, 6Tx, 6Ux, 6Vx, 6Wx, 6Xx, 6Yx, 73x • 0492-CTO, 22x, 23x, 24x, 25x, 26x, 28x, 29x, 2Ax, 2Bx, 2Cx, 2Dx, 2Ex, 2Hx, 2Kx, 2Nx, 2Sx, 2Tx, 2Ux, 2Vx, 2Wx, 2Xx, 2Yx, 32x, 33x, 34x, 35x, 38x, 3Dx, 3Ex, 3Fx, 3Gx, 3Hx, 3Jx, 3Kx	60Y3199	N
19	Bluetooth daughter card (BDC-2.1) • 0196-CTO, 22x, 23x, 24x, 25x, 26x, 27x, 28x, 29x, 2Ax, 2Bx, 2Cx, 2Dx, 2Ex, 2Fx, 2Gx, 2Hx, 2Jx, 2Kx, 2Lx, 2Mx, 2Px, 2Qx, 2Rx, 2Tx, 2Ux, 2Vx, 2Wx, 2Xx, 2Yx, 2Zx, 32x, 33x, 34x, 35x, 36x, 37x, 38x, 39x, 3Ax, 3Bx, 3Cx, 3Dx, 3Ex, 3Fx, 3Gx, 3Jx, 3Kx, 3Lx, 3Mx, 3Nx, 3Px, 3Qx, 3Rx, 3Sx, 3Tx, 3Yx, 3Zx, 42x, 43x, 45x, 46x, 47x, 48x, 49x, 4Ax, 4Bx, 4Cx, 4Ex, 4Mx, 4Qx, 4Rx, 4Sx, 4Ux, 4Vx, 4Wx, 4Xx • 0197-CTO, 23x, 24x, 2Ax, 2Cx, 2Dx, 2Ex, 2Fx, 2Hx, 2Jx, 2Kx, 2Lx, 2Px, 2Qx, 2Rx, 2Sx, 2Tx, 2Ux, 2Vx, 2Wx, 2Zx, 32x, 33x, 34x, 35x, 36x, 37x, 38x, 39x, 3Ax, 3Bx, 3Cx, 3Dx, 3Ex, 3Gx, 3Hx, 3Jx, 3Kx, 3Mx, 3Nx, 3Px, 3Qx, 3Rx, 3Sx, 3Xx, 44x, 49x, 4Ex, 4Kx, 4Qx, 4Rx, 4Sx, 4Tx, 4Ux, 4Vx, 4Wx, 4Xx, 4Yx, 4Zx, 52x, 53x, 54x, 55x, 56x, 57x, 58x, 59x, 5Ax, 5Bx, 5Cx, 5Dx, 5Ex, 5Fx, 5Gx, 5Hx, 5Jx, 5Kx, 5Lx, 5Mx, 5Nx, 5Px, 5Qx, 5Rx, 5Sx, 5Tx, 5Ux, 5Vx, 5Wx, 5Xx, 5Yx, 5Zx, 62x, 63x, 64x, 65x, 66x, 67x, 68x, 69x, 6Ax, 6Ex, 6Gx, 6Hx, 6Jx, 6Kx, 6Lx, 6Mx, 6Nx, 6Px, 6Qx, 6Rx, 6Sx, 6Tx, 6Ux, 6Vx, 6Wx, 6Xx, 6Yx, 73x • 0492-CTO, 22x, 23x, 24x, 25x, 26x, 28x, 29x, 2Ax, 2Bx, 2Cx, 2Dx, 2Ex, 2Hx, 2Kx, 2Nx, 2Sx, 2Tx, 2Ux, 2Vx, 2Wx, 2Xx, 2Yx, 32x, 33x, 34x, 35x, 38x, 3Dx, 3Ex, 3Fx, 3Gx, 3Hx, 3Jx, 3Kx	60Y3213	N
20	Backup battery	93P4905	N
21	TrackPoint caps	91P9642	*
—	AC adapter (see “AC adapters” on page 130.)		

LCD FRUs

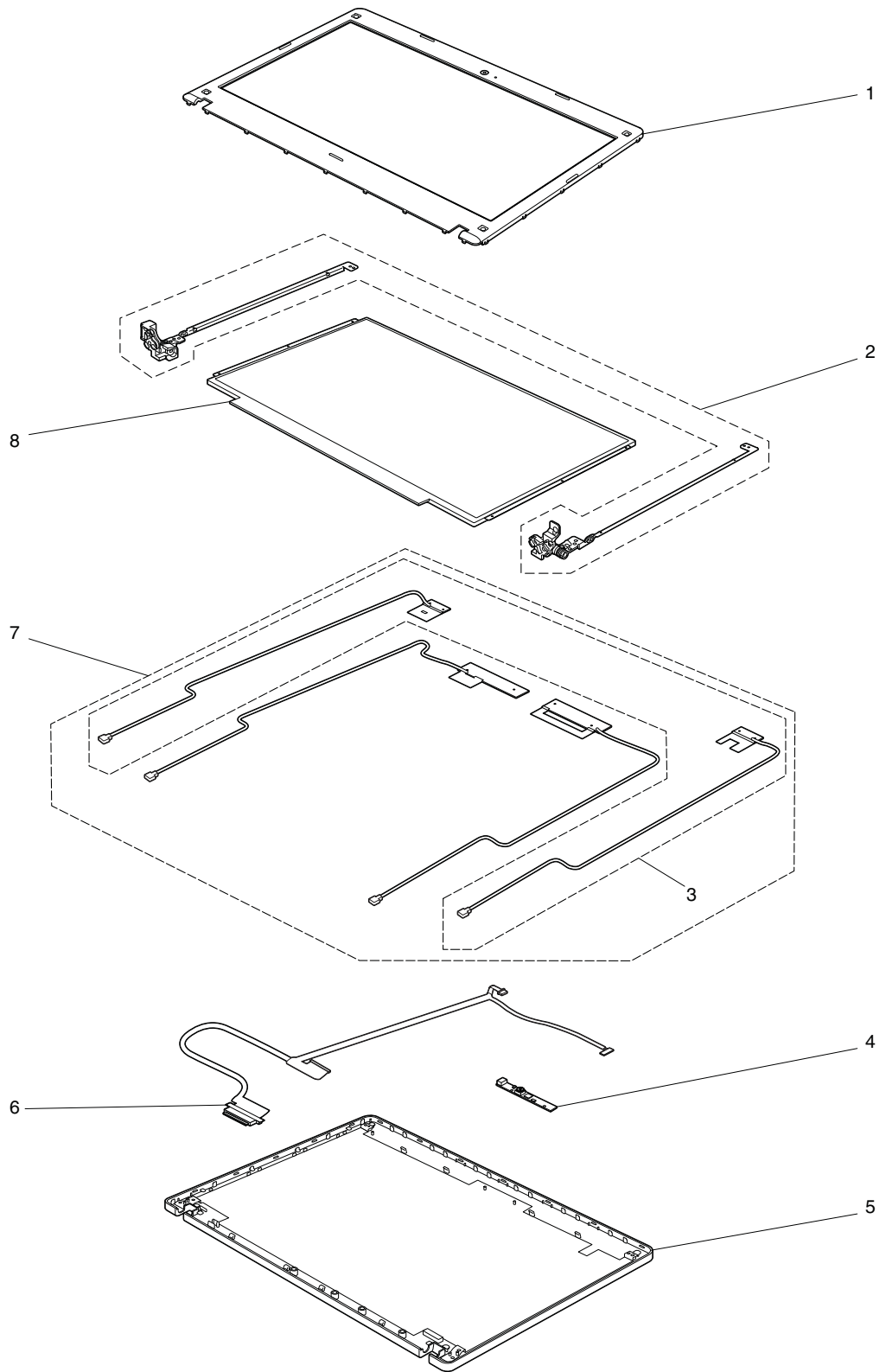

Table 30. Parts list—13.3-inch HD LED-backlight LCD

No.	FRU (13.3-inch HD LED-backlight LCD)	FRU no.	CRU ID
1	LCD bezel assembly	60Y5527	N
2	<p>Hinges, black</p> <ul style="list-style-type: none"> • 0196-CTO, 22x, 24x, 25x, 26x, 27x, 28x, 2Ax, 2Bx, 2Cx, 2Dx, 2Ex, 2Fx, 2Gx, 2Hx, 2Mx, 2Px, 2Rx, 2Tx, 2Vx, 2Wx, 2Xx, 2Yx, 32x, 33x, 35x, 36x, 38x, 39x, 3Cx, 3Ex, 3Gx, 3Hx, 3Kx, 3Lx, 3Nx, 3Px, 3Qx, 3Rx, 3Ux, 3Yx, 3Zx, 42x, 43x, 44x, 46x, 47x, 48x, 49x, 4Ax, 4Bx, 4Cx, 4Dx, 4Ex, 4Fx, 4Gx, 4Jx, 4Lx, 4Mx, 4Sx, 4Ux, 4Wx, 4Xx, 4Yx, 54x • 0197-CTO, 22x, 23x, 25x, 27x, 28x, 29x, 2Ax, 2Dx, 2Ex, 2Fx, 2Jx, 2Kx, 2Mx, 2Nx, 2Px, 2Qx, 2Rx, 2Sx, 2Ux, 2Vx, 2Wx, 32x, 33x, 36x, 37x, 38x, 3Ax, 3Bx, 3Cx, 3Fx, 3Gx, 3Hx, 3Kx, 3Lx, 3Mx, 3Nx, 3Px, 3Qx, 3Tx, 3Ux, 3Vx, 3Wx, 3Xx, 3Yx, 3Zx, 42x, 43x, 44x, 45x, 46x, 47x, 48x, 49x, 4Ax, 4Bx, 4Cx, 4Dx, 4Ex, 4Rx, 4Sx, 4Tx, 4Ux, 4Xx, 4Yx, 4Zx, 52x, 53x, 54x, 55x, 56x, 57x, 58x, 59x, 5Ax, 5Bx, 5Cx, 5Dx, 5Ex, 5Xx, 5Yx, 5Zx, 65x, 66x, 67x, 68x, 69x, 6Ax, 6Bx, 6Dx, 6Ex, 6Gx, 6Jx, 6Lx, 6Mx, 6Qx, 6Rx, 6Sx, 6Tx, 6Vx, 6Wx, 6Zx, 73x • 0492-CTO, 22x, 23x, 25x, 28x, 2Bx, 2Cx, 2Fx, 2Gx, 2Hx, 2Jx, 2Kx, 2Lx, 2Mx, 2Sx, 2Tx, 2Vx, 33x, 35x, 36x, 37x, 38x, 39x, 3Ax, 3Dx, 3Fx, 3Gx, 3Jx, 3Kx 	60Y5525	N
2	<p>Hinges, black</p> <ul style="list-style-type: none"> • 0196-CTO, 22x, 24x, 25x, 26x, 27x, 28x, 2Ax, 2Bx, 2Cx, 2Dx, 2Ex, 2Fx, 2Gx, 2Hx, 2Mx, 2Px, 2Rx, 2Tx, 2Vx, 2Wx, 2Xx, 2Yx, 32x, 33x, 35x, 36x, 38x, 39x, 3Cx, 3Ex, 3Gx, 3Hx, 3Kx, 3Lx, 3Nx, 3Px, 3Qx, 3Rx, 3Ux, 3Yx, 3Zx, 42x, 43x, 44x, 46x, 47x, 48x, 49x, 4Ax, 4Bx, 4Cx, 4Dx, 4Ex, 4Fx, 4Gx, 4Jx, 4Lx, 4Mx, 4Sx, 4Ux, 4Wx, 4Xx, 4Yx, 54x • 0197-CTO, 22x, 23x, 25x, 27x, 28x, 29x, 2Ax, 2Dx, 2Ex, 2Fx, 2Jx, 2Kx, 2Mx, 2Nx, 2Px, 2Qx, 2Rx, 2Sx, 2Ux, 2Vx, 2Wx, 32x, 33x, 36x, 37x, 38x, 3Ax, 3Bx, 3Cx, 3Fx, 3Gx, 3Hx, 3Kx, 3Lx, 3Mx, 3Nx, 3Px, 3Qx, 3Tx, 3Ux, 3Vx, 3Wx, 3Xx, 3Yx, 3Zx, 42x, 43x, 44x, 45x, 46x, 47x, 48x, 49x, 4Ax, 4Bx, 4Cx, 4Dx, 4Ex, 4Rx, 4Sx, 4Tx, 4Ux, 4Xx, 4Yx, 4Zx, 52x, 53x, 54x, 55x, 56x, 57x, 58x, 59x, 5Ax, 5Bx, 5Cx, 5Dx, 5Ex, 5Xx, 5Yx, 5Zx, 65x, 66x, 67x, 68x, 69x, 6Ax, 6Bx, 6Dx, 6Ex, 6Gx, 6Jx, 6Lx, 6Mx, 6Qx, 6Rx, 6Sx, 6Tx, 6Vx, 6Wx, 6Zx, 73x • 0492-CTO, 22x, 23x, 25x, 28x, 2Bx, 2Cx, 2Fx, 2Gx, 2Hx, 2Jx, 2Kx, 2Lx, 2Mx, 2Sx, 2Tx, 2Vx, 33x, 35x, 36x, 37x, 38x, 39x, 3Ax, 3Dx, 3Fx, 3Gx, 3Jx, 3Kx 	60Y5526	N
2	<p>Hinges, silver</p> <ul style="list-style-type: none"> • 0196-CTO, 23x, 29x, 2Jx, 2Kx, 2Lx, 2Qx, 2Ux, 2Zx, 34x, 37x, 3Ax, 3Bx, 3Dx, 3Fx, 3Jx, 3Mx, 3Sx, 3Tx, 45x, 4Nx, 4Px, 4Qx, 4Rx, 4Vx, 53x • 0197-CTO, 24x, 26x, 2Cx, 2Hx, 2Lx, 2Tx, 2Zx, 34x, 35x, 39x, 3Dx, 3Ex, 3Jx, 3Rx, 3Sx, 4Fx, 4Gx, 4Hx, 4Jx, 4Kx, 4Lx, 4Mx, 4Nx, 4Px, 4Qx, 4Vx, 4Wx, 5Fx, 5Gx, 5Hx, 5Jx, 5Kx, 5Lx, 5Mx, 5Nx, 5Px, 5Qx, 5Rx, 5Sx, 5Tx, 5Ux, 5Vx, 5Wx, 62x, 63x, 64x, 6Cx, 6Hx, 6Kx, 6Nx, 6Px, 6Ux, 6Xx, 6Yx, 72x • 0492-CTO, 24x, 26x, 29x, 2Ax, 2Dx, 2Ex, 2Nx, 2Px, 2Qx, 2Rx, 2Ux, 2Wx, 2Xx, 2Yx, 2Zx, 32x, 34x, 3Bx, 3Cx, 3Ex, 3Hx 	75Y4451	N
2	<p>Hinges, silver</p> <ul style="list-style-type: none"> • 0196-CTO, 23x, 29x, 2Jx, 2Kx, 2Lx, 2Qx, 2Ux, 2Zx, 34x, 37x, 3Ax, 3Bx, 3Dx, 3Fx, 3Jx, 3Mx, 3Sx, 3Tx, 45x, 4Nx, 4Px, 4Qx, 4Rx, 4Vx, 53x • 0197-CTO, 24x, 26x, 2Cx, 2Hx, 2Lx, 2Tx, 2Zx, 34x, 35x, 39x, 3Dx, 3Ex, 3Jx, 3Rx, 3Sx, 4Fx, 4Gx, 4Hx, 4Jx, 4Kx, 4Lx, 4Mx, 4Nx, 4Px, 4Qx, 4Vx, 4Wx, 5Fx, 5Gx, 5Hx, 5Jx, 5Kx, 5Lx, 5Mx, 5Nx, 5Px, 5Qx, 5Rx, 5Sx, 5Tx, 5Ux, 5Vx, 5Wx, 62x, 63x, 64x, 6Cx, 6Hx, 6Kx, 6Nx, 6Px, 6Ux, 6Xx, 6Yx, 72x • 0492-CTO, 24x, 26x, 29x, 2Ax, 2Dx, 2Ex, 2Nx, 2Px, 2Qx, 2Rx, 2Ux, 2Wx, 2Xx, 2Yx, 2Zx, 32x, 34x, 3Bx, 3Cx, 3Ex, 3Hx 	75Y4452	N

Table 30. Parts list—13.3-inch HD LED-backlight LCD (continued)

No.	FRU (13.3-inch HD LED-backlight LCD)	FRU no.	CRU ID
3	<p>Wireless LAN antenna cable set</p> <ul style="list-style-type: none"> 0196-CTO, 23x, 24x, 25x, 26x, 27x, 28x, 29x, 2Ax, 2Cx, 2Ex, 2Fx, 2Hx, 2Jx, 2Qx, 2Rx, 2Tx, 2Ux, 2Vx, 2Xx, 2Zx, 32x, 33x, 34x, 35x, 36x, 37x, 38x, 39x, 3Ax, 3Bx, 3Cx, 3Dx, 3Ex, 3Fx, 3Gx, 3Hx, 3Jx, 3Kx, 3Lx, 3Mx, 3Nx, 3Px, 3Qx, 3Rx, 3Sx, 3Tx, 3Ux, 3Yx, 3Zx, 43x, 44x, 45x, 46x, 47x, 48x, 49x, 4Bx, 4Cx, 4Dx, 4Ex, 4Fx, 4Gx, 4Jx, 4Lx, 4Mx, 4Nx, 4Px, 4Qx, 4Vx, 4Wx, 4Xx, 4Yx, 53x, 54x 0197-CTO, 25x, 26x, 27x, 28x, 29x, 2Ax, 2Cx, 2Dx, 2Ex, 2Fx, 2Hx, 2Jx, 2Kx, 2Lx, 2Mx, 2Nx, 2Px, 2Qx, 2Rx, 2Tx, 2Ux, 32x, 33x, 34x, 35x, 36x, 37x, 39x, 3Ax, 3Bx, 3Cx, 3Dx, 3Ex, 3Gx, 3Hx, 3Jx, 3Kx, 3Mx, 3Nx, 3Px, 3Qx, 3Rx, 3Sx, 3Tx, 3Ux, 3Vx, 3Wx, 3Xx, 3Yx, 3Zx, 42x, 43x, 44x, 45x, 46x, 47x, 48x, 49x, 4Ax, 4Bx, 4Cx, 4Dx, 4Ex, 4Fx, 4Gx, 4Hx, 4Jx, 4Kx, 4Lx, 4Mx, 4Nx, 4Px, 4Qx, 4Rx, 4Tx, 4Vx, 4Xx, 4Yx, 4Zx, 52x, 53x, 54x, 55x, 56x, 57x, 58x, 59x, 5Ax, 5Bx, 5Cx, 5Dx, 5Ex, 5Fx, 5Gx, 5Hx, 5Jx, 5Kx, 5Lx, 5Mx, 5Nx, 5Px, 5Qx, 5Rx, 5Sx, 5Tx, 5Ux, 5Vx, 5Wx, 5Xx, 5Yx, 5Zx, 62x, 65x, 68x, 6Bx, 6Cx, 6Dx, 6Ex, 6Gx, 6Hx, 6Jx, 6Kx, 6Lx, 6Nx, 6Qx, 6Sx, 6Tx, 6Ux, 6Vx, 6Wx, 6Xx, 6Yx, 6Zx, 72x, 73x 0492-CTO, 22x, 23x, 24x, 26x, 28x, 29x, 2Bx, 2Dx, 2Fx, 2Gx, 2Hx, 2Jx, 2Kx, 2Lx, 2Mx, 2Nx, 2Px, 2Qx, 2Rx, 2Sx, 2Ux, 2Vx, 2Wx, 2Xx, 2Yx, 2Zx, 32x, 33x, 34x, 35x, 36x, 37x, 38x, 39x, 3Ax, 3Bx, 3Cx, 3Dx, 3Ex, 3Fx, 3Gx, 3Hx, 3Jx, 3Kx 	45M2902	N
4	Integrated camera, 0.3 MP	60Y5744	N
5	<p>LCD rear cover assembly (midnight black, smooth)</p> <ul style="list-style-type: none"> 0196-CTO, 24x, 26x, 28x, 2Ax, 2Bx, 2Cx, 2Dx, 2Ex, 2Px, 2Tx, 2Xx, 33x, 35x, 39x, 3Ex, 3Hx, 3Ux, 3Yx, 3Zx, 42x, 43x, 48x, 49x, 4Ax, 4Jx, 4Lx, 4Mx, 4Ux, 4Xx, 54x 0197-CTO, 25x, 27x, 28x, 2Dx, 2Kx, 2Mx, 2Nx, 2Px, 2Qx, 2Rx, 2Sx, 2Ux, 2Vx, 2Wx, 32x, 3Cx, 3Fx, 3Hx, 3Lx, 3Nx, 3Qx, 45x, 46x, 47x, 48x, 49x, 4Ax, 4Bx, 4Cx, 4Dx, 4Ex, 4Rx, 4Sx, 5Xx, 5Yx, 5Zx, 65x, 66x, 67x, 6Dx, 6Ex, 6Tx, 6Wx 0492-CTO, 25x, 2Kx, 2Lx, 2Mx, 2Sx, 2Tx, 2Vx, 35x, 39x, 3Ax, 3Dx, 3Gx, 3Kx 	60Y5522	N
5	<p>LCD rear cover assembly (midnight black, gloss)</p> <ul style="list-style-type: none"> 0196-CTO, 22x, 25x, 27x, 2Fx, 2Gx, 2Hx, 2Mx, 2Rx, 2Vx, 2Wx, 2Yx, 32x, 36x, 38x, 3Cx, 3Gx, 3Kx, 3Lx, 3Nx, 3Px, 3Qx, 3Rx, 44x, 46x, 47x, 4Bx, 4Cx, 4Dx, 4Ex, 4Fx, 4Gx, 4Sx, 4Wx, 4Yx 0197-CTO, 23x, 29x, 2Ax, 2Ex, 2Fx, 2Jx, 33x, 36x, 37x, 38x, 3Ax, 3Bx, 3Gx, 3Kx, 3Mx, 3Px, 3Tx, 3Ux, 3Vx, 3Wx, 3Xx, 3Yx, 3Zx, 42x, 43x, 44x, 4Tx, 4Ux, 4Xx, 4Yx, 4Zx, 52x, 53x, 54x, 55x, 56x, 57x, 58x, 59x, 5Ax, 5Bx, 5Cx, 5Dx, 5Ex, 68x, 69x, 6Ax, 6Bx, 6Gx, 6Jx, 6Lx, 6Mx, 6Qx, 6Rx, 6Sx, 6Vx, 6Zx, 73x 0492-CTO, 22x, 23x, 28x, 2Bx, 2Cx, 2Fx, 2Gx, 2Hx, 2Jx, 33x, 36x, 37x, 38x, 3Fx, 3Jx 	60Y5523	N
5	<p>LCD rear cover assembly (heatwave red, gloss)</p> <ul style="list-style-type: none"> 0196-CTO, 23x, 29x, 2Jx, 2Kx, 2Lx, 2Qx, 2Ux, 2Zx, 34x, 37x, 3Ax, 3Bx, 3Dx, 3Fx, 3Jx, 3Mx, 3Sx, 3Tx, 45x, 4Nx, 4Px, 4Qx, 4Rx, 4Vx, 53x 0197-CTO, 24x, 26x, 2Cx, 2Hx, 2Lx, 2Tx, 2Zx, 34x, 35x, 39x, 3Dx, 3Ex, 3Jx, 3Rx, 3Sx, 4Fx, 4Gx, 4Hx, 4Jx, 4Kx, 4Lx, 4Mx, 4Nx, 4Px, 4Qx, 4Vx, 4Wx, 5Fx, 5Gx, 5Hx, 5Jx, 5Kx, 5Lx, 5Mx, 5Nx, 5Px, 5Qx, 5Rx, 5Sx, 5Tx, 5Ux, 5Vx, 5Wx, 62x, 63x, 64x, 6Cx, 6Hx, 6Kx, 6Nx, 6Px, 6Ux, 6Xx, 6Yx, 72x 0492-CTO, 24x, 26x, 29x, 2Ax, 2Dx, 2Ex, 2Nx, 2Px, 2Qx, 2Rx, 2Ux, 2Wx, 2Xx, 2Yx, 2Zx, 32x, 34x, 3Bx, 3Cx, 3Ex, 3Hx 	60Y5524	N
6	LCD cable	45M2900	N
7	<p>Wireless LAN/WAN antenna cable set</p> <ul style="list-style-type: none"> 0196-CTO, 22x, 2Bx, 2Dx, 2Gx, 2Kx, 2Lx, 2Mx, 2Px, 2Wx, 2Yx, 42x, 4Ax, 4Rx, 4Sx, 4Ux 0197-CTO, 23x, 24x, 2Sx, 2Vx, 2Wx, 2Zx, 38x, 3Fx, 3Lx, 4Sx, 4Ux, 4Wx, 63x, 64x, 66x, 67x, 69x, 6Ax, 6Mx, 6Px, 6Rx 0492-CTO, 25x, 2Ax, 2Cx, 2Ex, 2Tx 	45M2903	N
8	LCD module, 13.3-inch High Definition (HD) LED-backlight, glair	27R2437	N
8	LCD module, 13.3-inch HD LED-backlight, glair	27R2435	N
8	LCD module, 13.3-inch HD LED-backlight, glair	27R2439	N

Keyboard

Table 31. Parts list—Keyboard

Language	FRU no.		CRU ID
Arabic	60Y9513	60Y9443	N
Belgian	60Y9514	60Y9444	
Brazilian Portuguese	60Y9512	60Y9442	
Bulgarian	60Y9515	60Y9445	
Canadian French (058)	60Y9510	60Y9440	
Canadian French (Acnor)	60Y9509	60Y9439	
Czech	60Y9516	60Y9446	
Danish	60Y9517	60Y9447	
Dutch	60Y9527	60Y9457	
Finnish, Swedish	60Y9534	60Y9464	
French	60Y9519	60Y9449	
German	60Y9520	60Y9450	
Greek (U.S. English and Greek layout)	60Y9521	60Y9451	
Hebrew	60Y9522	60Y9452	
Hungarian	60Y9523	60Y9453	
Icelandic	60Y9524	60Y9454	
Italian	60Y9525	60Y9455	
Japanese	60Y9539	60Y9469	
Kazakhstan	60Y9526	60Y9456	
Korean	60Y9540	60Y9470	
Latin American Spanish	60Y9511	60Y9441	
Norwegian	60Y9528	60Y9458	
Polish	60Y9529	60Y9459	
Portuguese	60Y9530	60Y9460	
Russian	60Y9531	60Y9461	
Slovak	60Y9532	60Y9462	
Slovenian	60Y9533	60Y9463	
Spanish	60Y9518	60Y9448	
Swiss	60Y9535	60Y9465	
Thai	60Y9542	60Y9472	
Traditional Chinese	60Y9541	60Y9471	
Turkish	60Y9536	60Y9466	
U.K. English	60Y9537	60Y9467	
U.S. English	60Y9508	60Y9438	
U.S. English (International, with a Euro symbol)	60Y9538	60Y9468	

AC adapters

Table 32. Parts list—2-pin AC adapters

FRU	FRU no.	CRU ID
2-pin (65 W, 20 V) adapter (models CTO, xxE, xxF, xxJ, xxL, xxP, xxS, xxU, xxY)	42T5282	*
2-pin (65 W, 20 V) adapter (models CTO, xxE, xxF, xxJ, xxL, xxP, xxS, xxU, xxY)	42T4423	
2-pin (65 W, 20 V) adapter (models CTO, xxE, xxF, xxJ, xxL, xxP, xxS, xxU, xxY)	42T4419	

Table 33. Parts list—3-pin AC adapters

FRU	FRU no.	CRU ID
3-pin (65 W, 20 V) adapter (models CTO, xxA, xxB, xxG, xxH, xxK, xxM, xxQ, xxT, xxV)	42T5283	*
3-pin (65 W, 20 V) adapter (models CTO, xxA, xxB, xxG, xxH, xxK, xxM, xxQ, xxT, xxV)	42T4421	
3-pin (65 W, 20 V) adapter (models CTO, xxA, xxB, xxG, xxH, xxK, xxM, xxQ, xxT, xxV)	42T4417	

Miscellaneous parts

Table 34. Parts list—Miscellaneous parts

FRU	FRU no.	CRU ID
Screw kit: <ul style="list-style-type: none">• M1.7 × 3 mm (black), wafer head (6)• M2 × 3 mm (black), wafer head (38)• M2 × 4 mm (silver), bind head (6)• M2 × 5 mm (black), wafer head (18)• M2.5 × 5 mm (black), wafer head (6)• M3 × 3.5 mm (black), wafer head (3)	60Y5521	N

Power cords

A ThinkPad power cord for a specific country or region is usually available only in that country or region:

Table 35. Parts list—2-pin power cords

Country or region	FRU no.		CRU ID
Argentina • models -CTO, xxY	42T5020	42T5105	*
Brazil • models -CTO, xxP	42T5180	42T5183	
Canada, U.S. • models -CTO, xxF, xxL, xxS, xxU	42T5008	42T5093	
Japan • models -CTO, xxE, xxJ	42T5014	42T5099	

Table 36. Parts list—3-pin power cords

Country or region	FRU no.		CRU ID
Australia, New Zealand • models -CTO, xxM	42T5050	42T5135	*
Bangladesh, Sri Lanka, South Africa • models -CTO, xxG	42T5056	42T5141	
Canada, U.S. • models -CTO, xxG, xxT	42T5004	42T5089	
China (P.R.C.) (other than Hong Kong S.A.R.) • models -CTO, xxC	42T5065	42T5150	
Denmark • models -CTO, xxG	42T5041	42T5126	
European countries • models -CTO, xxG	42T5029	42T5114	
India • models -CTO, xxQ	42T5083	42T5168	
Israel • models -CTO, xxG	42T5062	42T5147	
Italy • models -CTO, xxG	42T5047	42T5132	
Korea • models -CTO, xxK	42T5077	42T5162	
Switzerland • models -CTO, xxG	42T5044	42T5129	
Taiwan • models -CTO, xxV	42T5071	42T5156	
U.K., China (Hong Kong S.A.R.) • models -CTO, xxB, xxG, xxH	42T5035	42T5120	

Recovery discs

Windows 7 Home Basic (32 bit) DVDs

Windows 7 Home Basic (32 bit) is preinstalled as the operating system in the following models:

- 0196-CTO, 2Zx, 3Hx, 4Fx, 4Gx, 4Jx, 4Lx, 4Nx, 4Px
- 0197-CTO, 2Jx, 2Rx, 2Vx, 2Zx, 39x, 3Tx, 3Ux, 3Vx, 3Wx, 3Yx, 3Zx, 42x, 43x, 45x, 46x, 47x, 48x, 4Ax, 4Bx, 4Cx, 4Dx, 4Fx, 4Gx, 4Hx, 4Jx, 4Lx, 4Mx, 4Nx, 4Px
- 0492-CTO, 2Fx, 2Gx, 2Hx, 2Kx, 2Lx, 2Nx, 2Px, 2Qx, 2Tx, 32x, 33x, 35x, 36x, 37x, 39x, 3Ax, 3Bx, 3Cx

Table 37. Parts list—Windows 7 Home Basic (32 bit) recovery DVDs

Language	P/N	CRU ID
Brazilian Portuguese	58Y4046	*
English	58Y4053	
Russian	58Y4049	
Russian (English-enabled)	58Y4048	
Serbian-Latin	58Y4051	
Simplified Chinese	58Y4047	
Spanish	58Y4050	
Turkish	58Y4052	

Windows 7 Home Premium (32 bit) DVDs

Windows 7 Home Premium (32 bit) is preinstalled as the operating system in the following models:

- 0196-CTO, 2Lx, 2Mx, 2Px, 2Yx, 32x, 33x, 34x, 4Ax, 4Dx, 4Mx, 4Qx, 4Rx, 4Sx, 4Ux, 4Yx, 53x, 54x
- 0197-CTO, 2Sx, 2Tx, 32x, 38x, 3Mx, 3Nx, 3Rx, 3Xx, 44x, 49x, 4Ex, 4Kx, 4Qx, 63x, 64x, 66x, 67x, 69x, 6Ax, 6Bx, 6Cx, 6Dx
- 0492-CTO, 2Jx, 2Mx, 2Rx, 2Sx, 2Ux, 2Vx, 2Wx, 2Zx, 34x, 38x, 3Dx, 3Ex, 3Fx, 3Kx

Table 38. Parts list—Windows 7 Home Premium (32 bit) recovery DVDs

Language	P/N	CRU ID
Brazilian Portuguese	58Y4054	*
English	58Y4064	
Korean	58Y4058	
Russian	58Y4060	
Russian (English-enabled)	58Y4059	
Simplified Chinese	58Y4055	
Spanish	58Y4061	
Traditional Chinese	58Y4056	
Traditional Chinese (Hong Kong S.A.R.)	58Y4057	

Windows 7 Home Premium (64 bit) DVDs

Windows 7 Home Premium (64 bit) is preinstalled as the operating system in the following models:

- 0196-CTO, 2Ux, 3Qx, 3Rx, 3Sx, 3Tx, 3Ux, 4Cx
- 0197-CTO, 25x, 27x, 29x, 2Ax, 2Cx, 2Dx, 2Mx, 2Px, 4Xx, 4Zx, 53x, 55x, 57x, 59x, 5Bx, 5Dx, 5Fx, 5Hx, 5Kx, 5Mx, 5Px, 5Rx, 5Tx, 5Vx, 6Lx, 6Mx, 6Nx, 6Px
- 0492-CTO, 2Ax, 2Bx, 2Cx, 2Yx

Table 39. Parts list—Windows 7 Home Premium (64 bit) recovery DVDs

Language	P/N	CRU ID
Czech	58Y4125	*
Danish	58Y4126	
English	58Y4140	
English, Finnish, and Swedish (in Sweden)	58Y4142	
English, French, German, and Dutch (in Belgium and Luxemburg)	58Y4141	
English, French, German, and Italian (in Switzerland)	58Y4143	
French	58Y4127	
German	58Y4129	
Greek	58Y4128	
Hebrew	58Y4130	
Hungarian	58Y4131	
Italian	58Y4132	
Japanese	58Y4133	
Polish	58Y4134	
Portuguese	58Y4135	
Romanian	58Y4136	
Serbian-Latin	58Y4523	
Slovak	58Y4137	
Slovenian	58Y4138	
Spanish	58Y4139	
Turkish	58Y4524	

Windows 7 Professional (32 bit) DVDs

Windows 7 Professional (32 bit) is preinstalled as the operating system in the following models:

- 0196-CTO, 24x, 29x, 2Cx, 2Ex, 2Fx, 2Hx, 2Jx, 2Xx, 35x, 36x, 3Bx, 3Ex, 3Fx, 3Gx, 3Jx, 3Kx, 3Px, 3Yx, 3Zx, 42x, 44x, 45x, 46x
- 0197-CTO, 28x, 2Hx, 2Kx, 2Lx, 33x, 3Ax, 3Cx, 3Dx, 3Fx, 3Gx, 3Jx, 3Lx, 4Rx, 4Tx, 4Vx, 4Yx, 52x, 54x, 56x, 58x, 5Ax, 5Cx, 5Ex, 5Gx, 5Jx, 5Lx, 5Nx, 5Qx, 5Sx, 5Ux, 5Wx, 5Xx, 5Yx, 5Zx, 6Ex, 6Gx, 6Hx, 6Sx, 6Tx, 6Ux, 6Vx, 6Wx, 6Xx, 6Zx, 72x, 73x
- 0492-CTO, 22x, 24x, 26x, 3Gx, 3Hx, 3Jx

Table 40. Parts list—Windows 7 Professional (32 bit) recovery DVDs

Language	P/N	CRU ID
Arabic	58Y4065	*
Brazilian Portuguese	58Y4066	
Czech	58Y4069	
Danish	58Y4070	
English	58Y4091	
English, Finnish, and Swedish (in Sweden)	58Y4093	
English, French, German, and Dutch (in Belgium and Luxemburg)	58Y4092	
English, French, German, and Italian (in Switzerland)	58Y4094	
French	58Y4071	
German	58Y4073	
Greek	58Y4072	
Hebrew	58Y4074	
Hungarian	58Y4076	
Italian	58Y4077	
Japanese	58Y4078	
Korean	58Y4079	
Norwegian	58Y4080	
Polish	58Y4081	
Portuguese	58Y4082	
Romanian	58Y4084	
Russian	58Y4085	
Russian (English-enabled)	58Y4083	
Serbian-Latin	58Y4089	
Simplified Chinese	58Y4067	
Slovak	58Y4086	
Slovenian	58Y4087	
Spanish	58Y4088	
Traditional Chinese	58Y4068	
Traditional Chinese (Hong Kong S.A.R.)	58Y4075	
Turkish	58Y4090	

Windows 7 Professional (64 bit) DVDs

Windows 7 Professional (64 bit) is preinstalled as the operating system in the following models:

- 0196-CTO, 22x, 23x, 25x, 26x, 27x, 28x, 2Ax, 2Bx, 2Dx, 2Gx, 2Kx, 2Vx, 2Wx, 37x, 38x, 39x, 3Ax, 47x
- 0197-CTO, 23x, 24x, 26x, 2Ex, 2Fx, 2Qx, 2Wx, 3Px, 3Qx, 3Sx, 4Sx, 4Ux, 4Wx, 6Qx, 6Rx, 6Yx
- 0492-CTO, 23x, 25x, 2Dx, 2Ex

Table 41. Parts list—Windows 7 Professional (64 bit) recovery DVDs

Language	P/N	CRU ID
Arabic	58Y4095	*
Brazilian Portuguese	58Y4096	
Czech	58Y4099	
Danish	58Y4100	
English	58Y4121	
English, Finnish, and Swedish (in Sweden)	58Y4123	
English, French, German, and Dutch (in Belgium and Luxemburg)	58Y4122	
English, French, German, and Italian (in Switzerland)	58Y4124	
French	58Y4101	
German	58Y4103	
Greek	58Y4102	
Hebrew	58Y4104	
Hungarian	58Y4106	
Italian	58Y4107	
Japanese	58Y4108	
Korean	58Y4109	
Norwegian	58Y4110	
Polish	58Y4111	
Portuguese	58Y4112	
Romanian	58Y4114	
Russian	58Y4115	
Russian (English-enabled)	58Y4113	
Serbian-Latin	58Y4119	
Simplified Chinese	58Y4097	
Slovak	58Y4116	
Slovenian	58Y4117	
Spanish	58Y4118	
Traditional Chinese	58Y4098	
Traditional Chinese (Hong Kong S.A.R.)	58Y4105	
Turkish	58Y4120	

Common service tools

Table 42. Parts list—Common service tools

Tool	P/N
Screwdriver kit	95F3598
1/4" drive spinner handle	1650840
1/4" Sq. to 1/4" hex torx adapter	93F2838
TR7-TR-10 tamper resistant torx bits	00P6967
Removal tool antenna RF connector	08K7159
USB 2.0 CD-RW/DVD-ROM combo drive II	40Y8687
USB cable	40Y8704
USB floppy diskette drive for maintenance diskette	05K9283
USB floppy diskette drive tool kit	27L3452
Test card for integrated Smart Card	42W7820
LENOVO ThinkPad Hardware Maintenance Diskette Version 1.76 or later Note: Download the file from the following Web site: http://www.lenovo.com/spm	—

Notices

Lenovo may not offer the products, services, or features discussed in this document in all countries. Consult your local Lenovo representative for information on the products and services currently available in your area. Any reference to a Lenovo product, program, or service is not intended to state or imply that only that Lenovo product, program, or service may be used. Any functionally equivalent product, program, or service that does not infringe any Lenovo intellectual property right may be used instead. However, it is the user's responsibility to evaluate and verify the operation of any other product, program, or service.

Lenovo may have patents or pending patent applications covering subject matter described in this document. The furnishing of this document does not give you any license to these patents. You can send license inquiries, in writing, to:

*Lenovo (United States), Inc.
1009 Think Place - Building One
Morrisville, NC 27560
U.S.A.
Attention: Lenovo Director of Licensing*

LENOVO GROUP LTD. PROVIDES THIS PUBLICATION "AS IS" WITHOUT WARRANTY OF ANY KIND, EITHER EXPRESS OR IMPLIED, INCLUDING, BUT NOT LIMITED TO, THE IMPLIED WARRANTIES OF NON-INFRINGEMENT, MERCHANTABILITY OR FITNESS FOR A PARTICULAR PURPOSE. Some jurisdictions do not allow disclaimer of express or implied warranties in certain transactions, therefore, this statement may not apply to you.

This information could include technical inaccuracies or typographical errors. Changes are periodically made to the information herein; these changes will be incorporated in new editions of the publication. Lenovo may make improvements and/or changes in the product(s) and/or the program(s) described in this publication at any time without notice.

The products described in this document are not intended for use in implantation or other life support applications where malfunction may result in injury or death to persons. The information contained in this document does not affect or change Lenovo product specifications or warranties. Nothing in this document shall operate as an express or implied license or indemnity under the intellectual property rights of Lenovo or third parties. All information contained in this document was obtained in specific environments and is presented as an illustration. The result obtained in other operating environments may vary.

Lenovo may use or distribute any of the information you supply in any way it believes appropriate without incurring any obligation to you.

Any references in this publication to non-Lenovo Web sites are provided for convenience only and do not in any manner serve as an endorsement of those Web sites. The materials at those Web sites are not part of the materials for this Lenovo product, and use of those Web sites is at your own risk.

Any performance data contained herein was determined in a controlled environment. Therefore, the result obtained in other operating environments may

vary significantly. Some measurements may have been made on development-level systems and there is no guarantee that these measurements will be the same on generally available systems. Furthermore, some measurements may have been estimated through extrapolation. Actual results may vary. Users of this document should verify the applicable data for their specific environment.

Trademarks

The following terms are trademarks of Lenovo in the United States, other countries or both:

- Active Protection System
- Lenovo®
- Rescue and Recovery®
- ThinkPad®
- ThinkVantage®
- TrackPoint®
- UltraNav®

IBM® (used under license) is trademark of the International Business Machines Corporation in the United States, other countries, or both.

Windows® is trademark of Microsoft Corporation in the United States, other countries, or both.

Intel® is trademark of Intel Corporation or its subsidiaries in the United States, other countries, or both:

Other company, product, or service names may be the trademarks or service marks of others.

ThinkPad

Part Number: 63Y0744

(1P) P/N: 63Y0744

