

BenQ

Joybee GP1 Mini Projector

User Manual

Welcome

Table of contents

Important safety instructions	3	Freezing the image	31
Introduction	7	Operating in a high altitude environment	32
Projector features	7	Adjusting the sound.....	32
Shipping contents.....	8	Personalizing the projector menu display.....	33
Projector exterior view.....	9	Shutting down the projector	33
Controls and functions	10	Projector menu operation	34
Projector	10	Presenting From a USB Reader	42
Positioning your projector	13	Entering USB Reader main screen	42
Obtaining a preferred projected image size	13	Playing back photos and movies	42
Connection	15	"PC-less" presentations	43
Connecting a computer	15	Using USB Reader menus.....	44
Connecting Video source devices.....	16	USB Reader menu operation.....	46
Connecting a composite Video source device.....	18	Projection with iPod Dock (Optional Accessory)	51
Connecting a USB Reader source device.....	19	Maintenance	52
Connecting an iPod Dock device (Optional Accessory).....	20	Care of the projector	52
Operation	21	Troubleshooting	54
Starting up the projector	21	Specifications	55
Using the menus.....	22	Projector specifications.....	55
Utilizing the password function	23	Dimensions.....	56
Switching input signal.....	25	Timing chart.....	56
Adjusting the projected image	25	Warranty and Copyright information	57
Magnifying and searching for details.....	27	Regulation statements	58
Selecting the aspect ratio	27		
Optimizing the image.....	28		
Hiding the image	31		

Important safety instructions

Your projector is designed and tested to meet the latest standards for safety of information technology equipment. However, to ensure safe use of this product, it is important that you follow the instructions mentioned in this manual and marked on the product.

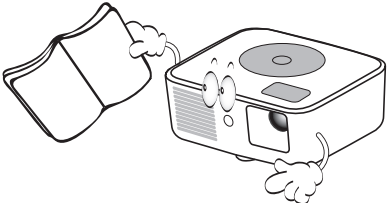
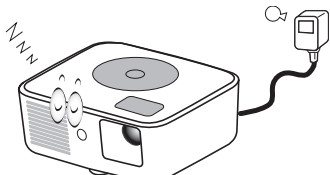
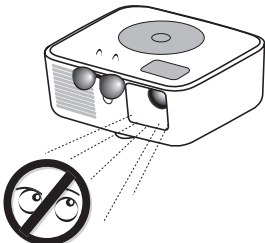
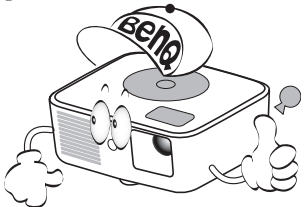
Safety Instructions	
<p>1. Please read this manual before you operate your projector. Save it for future reference.</p>	<p>4. In some countries, the line voltage is NOT stable. This projector is designed to operate safely within a mains voltage of 19 volts AC, but could fail if power cuts or surges of ± 10 volts occur. In areas where the mains voltage may fluctuate or cut out, it is recommended that you connect your projector through a power stabilizer, surge protector or uninterruptible power supply (UPS).</p>
	
<p>2. Do not look straight at the projector lens during operation. The intense light beam may damage your eyes.</p>	<p>5. Do not block the projection lens with any objects when the projector is under operation as this could cause the objects to become heated and deformed or even cause a fire. To temporarily turn off the lamp, press BLANK on the projector or remote control.</p>
	
<p>3. Refer servicing to qualified service personnel.</p>	
	

Safety Instructions (Continued)

6. Do not operate lamps beyond the rated lamp life. Excessive operation of lamps beyond the rated life could cause them to break on rare occasions.

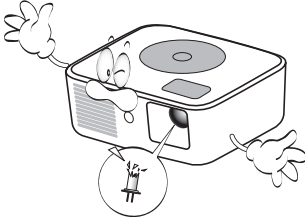

7. Never replace any electronic components unless the projector is unplugged.

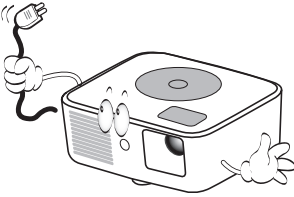

8. Do not place this product on an unstable cart, stand, or table. The product may fall, sustaining serious damage.

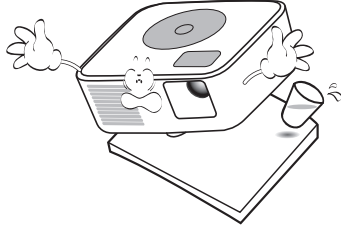

9. Do not attempt to disassemble this projector. There are dangerous high voltages inside which may cause death if you should come into contact with live parts. Refer servicing only to suitably qualified professional service personnel.

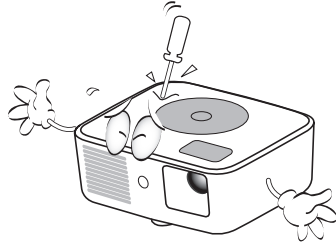

10. When the projector is under operation, you may sense some heated air and odor from its ventilation grill. It is a normal phenomenon and not a product defect.

Safety Instructions (Continued)

11. Do not place this projector in any of the following environments.
- Space that is poorly ventilated or confined. Allow at least 50 cm clearance from walls and free flow of air around the projector.
 - Locations where temperatures may become excessively high, such as the inside of a car with all windows rolled up.
 - Locations where excessive humidity, dust, or cigarette smoke may contaminate optical components, shortening the projector's life span and darkening the image.

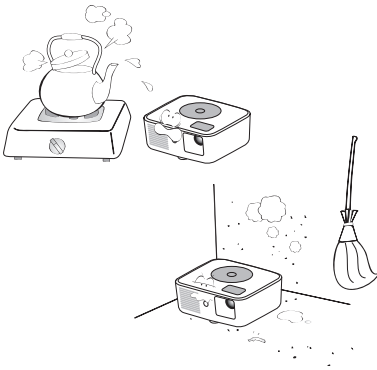

- Locations near fire alarms
- Locations with an ambient temperature above 60°C / 140°F
- Locations where the altitudes are higher than 12000 m (40000 feet).

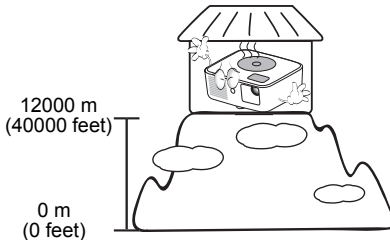

12. Do not block the ventilation holes.
- Do not place this projector on a blanket, bedding or any other soft surface.
 - Do not cover this projector with a cloth or any other item.
 - Do not place inflammables near the projector.

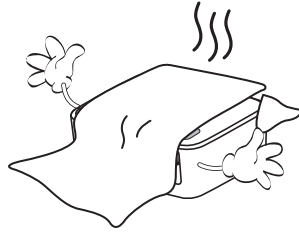

If the ventilation holes are seriously obstructed, overheating inside the projector may result in a fire.

13. Always place the projector on a level, horizontal surface during operation.

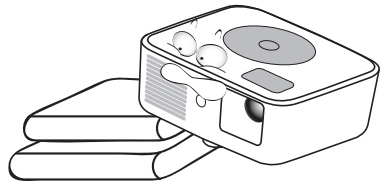

14. Do not stand the projector on end vertically. Doing so may cause the projector to fall over, causing injury or resulting in damage to the projector.

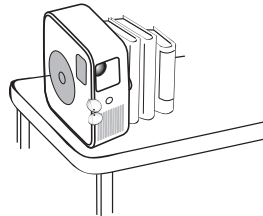

Safety Instructions (Continued)

15. Do not step on the projector or place any objects upon it. Besides probable physical damage to the projector, doing so may result in accidents and possible injury.



16. Do not place liquids near or on the projector. Liquids spilled into the projector may cause it to fail. If the projector does become wet, disconnect it from the power supply's wall socket and call BenQ to have the projector serviced.

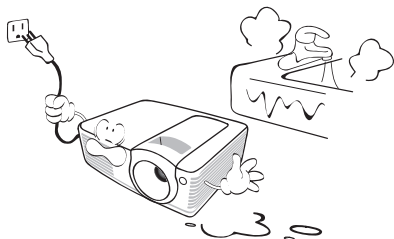

Introduction

Projector features

The projector integrates high-performance optical engine projection and a user-friendly design to deliver high reliability and ease of use.

The projector offers the following features.

- USB reader making photo and movie play quick
- Wall color correction allowing projection on surfaces of several predefined colors
- Quick auto search speeding up the signal detecting process
- Selectable password protected function
- Up to 5 sets of picture modes providing multiple choices for different projection purposes
- Digital keystone correction to correct distorted images
- Ability to display 16.7 million colors
- Multi-language On-Screen Display (OSD) menus
- Component HDTV compatibility (YPbPr)



- **The apparent brightness of the projected image will vary depending on the ambient lighting conditions, selected input signal contrast/brightness settings, and is directly proportional to projection distance.**
- **The lamp brightness will decline over time and may vary within the lamp manufacturers specifications. This is normal and expected behavior.**

Shipping contents

Carefully unpack and verify that you have all of the items shown below. If any of these items are missing, please contact your place of purchase.

Standard accessories

 The supplied accessories will be suitable for your region, and may differ from those illustrated.

*The warranty card is only supplied in some specific regions. Please consult your dealer for detailed information.

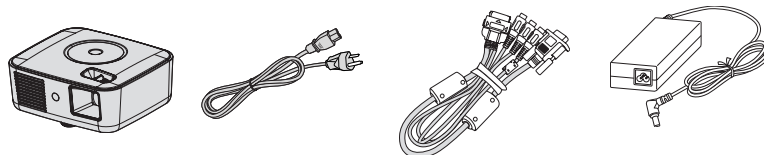

Projector

Power cord

Multi-input cable

AC adapter



Safety manual

Quick start guide

User manual CD

Warranty card*



Carrying bag

Remote control
with battery

 Pull the tab before using the remote control.

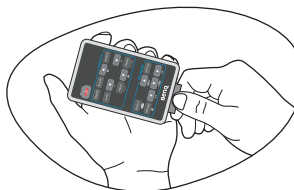

Optional accessories

1. iPod Dock with cable

2. Carrying bag

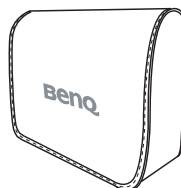
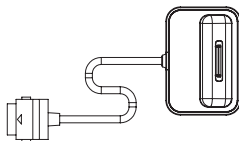

 Optional accessories may vary by retailers. Please contact your sales dealer for purchase.

* The warranty card is only supplied in some specific regions. Please contact your sales dealer for detailed information.

Projector exterior view

Front/upper side

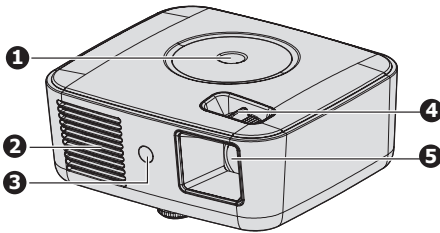

1. External control panel
(See "Projector" on page 10 for details.)
2. Vent (heated air exhaust)
3. Front IR remote sensor
4. Focus ring
5. Projection lens

Rear/lower side

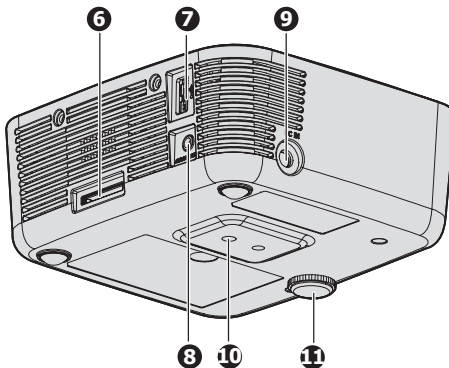

6. Multi-input socket
-RGB (PC)/Component video
(YPbPr/ YCbCr) /Composite video/
Audio input (L/R)
7. USB Reader slot
8. Audio output socket (only for USB
Reader)
9. AC adapter inlet
10. Tripod socket
11. Adjuster foot

Controls and functions

Projector

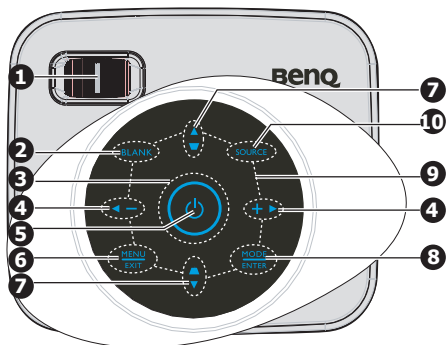

1. **Focus ring**
Adjusts the focus of the projected image.
See ["Fine-tuning the image clarity"](#) on page 26 for details.
2. **BLANK**
Used to hide the screen picture. See ["Hiding the image"](#) on page 31 for details.
3. **Power and Ring LED indicator**
Indicates the power on or off and warning status. See ["Indicators"](#) on page 53 for details.
4. **Volume/Arrow keys (◀ / -, ▶ / +)**
Magnifies or reduces the volume level. See ["Adjusting the sound"](#) on page 32 for details.
Magnifies or reduces the volume level. See ["Adjusting the sound"](#) on page 32 for details.
When the On-Screen Display (OSD) menu is activated, the #4 and #7 keys are used as directional arrows to select the desired menu items and to make adjustments. See ["Using the menus"](#) on page 22 for details.
5. **Power**
Toggles the projector between standby mode and on.
See ["Starting up the projector"](#) on page 21 and ["Shutting down the projector"](#) on page 33 for details.
6. **MENU/EXIT**
Turns on the On-Screen Display (OSD) menu. Goes back to previous OSD menu, exits and saves menu settings. See ["Using the menus"](#) on page 22 for details.
7. **Keystone/Arrow keys (◻ / ▲ Up, ◻ / ▼ Down)**
Manually corrects distorted images resulting from an angled projection. See ["Correcting keystone"](#) on page 26 for details.
8. **MODE/ENTER**
Selects an available picture setup mode. See ["Selecting a picture mode"](#) on page 28 for details.
Enacts the selected On-Screen Display (OSD) menu item. See ["Using the menus"](#) on page 22 for details.
9. **Key LED indicator**
Indicates the touch-key and source status. See ["Indicators"](#) on page 53 for details.
10. **SOURCE**
Displays the source selection bar. See ["Switching input signal"](#) on page 25 for details.

Keypad functions under USB mode

#	Keypad	Keypad Operation
2	BLANK	Used to hide the screen picture.
4	Volume/Arrow keys	Acts as fast reverse play (◀ / ◀◀) or fast forward play (▶ / ▶▶) during playback.
6	MENU/ EXIT	Stops playback and goes back to USB Reader main menu. Goes back to previous OSD menu. Press for three seconds to display Projector Menu
7	Keystone/Arrow keys	Acts as previous file selection (▲ / ◀◀) or next file selection (▼ / ▶▶).
8	MODE/ ENTER	Enacts the selected menu item. ▶ Plays back and pauses the photo and movie.

Remote control

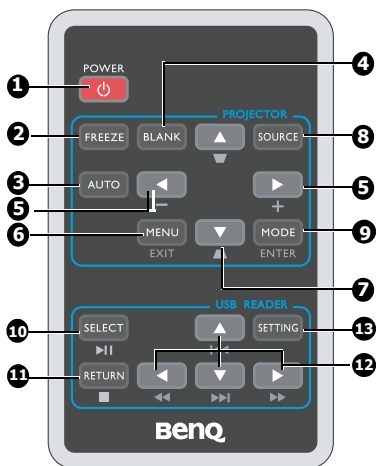

1. **POWER**
Toggles the projector between standby mode and on. See ["Starting up the projector"](#) on page 21 and ["Shutting down the projector"](#) on page 33 for details.

PROJECTOR

2. **FREEZE**
Freezes the projected image. See ["Freezing the image"](#) on page 31 for details.
3. **AUTO**
Automatically determines the best picture timings for the displayed image. See ["Auto-adjusting the image"](#) on page 26 for details.
4. **BLANK**
Used to hide the screen picture. See ["Hiding the image"](#) on page 31 for details.
5. **Volume/Arrow keys (◀/-, ▶/+)**
Magnifies or reduces the volume level. See ["Adjusting the sound"](#) on page 32 for details.
When the On-Screen Display (OSD) menu is activated, the #5 and #7 keys are used as directional arrows to select the desired menu items and to make adjustments. See ["Using the menus"](#) on page 22 for details.

6. **MENU/EXIT**
Turns on the On-Screen Display (OSD) menu. Goes back to previous OSD menu, exits and saves menu settings. See ["Using the menus"](#) on page 22 for details.

7. **Keystone/Arrow keys (◻/▲Up, ◻/▼Down)**
Manually corrects distorted images resulting from an angled projection. See ["Correcting keystone"](#) on page 26 for details.

8. **SOURCE**
Displays the source selection bar. See ["Switching input signal"](#) on page 25 for details.

9. **MODE/ENTER**
Depending upon which input signal is selected, selects an available picture setup mode. See ["Selecting a picture mode"](#) on page 28 for details.
Enacts the selected On-Screen Display (OSD) menu item. See ["Using the menus"](#) on page 22 for details.

USB READER

10. **SELECT/▶||**
Plays back and pauses the photo and movie. Enacts the selected USB On-Screen Display (OSD) menu item.
11. **RETURN/■**
Stops playback. Goes back to USB Reader main screen.
12. **Arrow keys (▲/▼/◀/▶)**
Uses ◀◀/▶▶ to play previous or next file. Use ◀/▶ to allow fast reverse play or fast forward play during playback. When the USB Reader On-Screen Display (OSD) menu is activated, arrow keys are used as directional arrows to select the desired menu items.
13. **SETTING**
Turns on the USB Reader On-Screen Display (OSD) menu. Exits and saves menu settings. See ["Using USB Reader menus"](#) on page 44 for details.

Remote control effective range

Infra-Red (IR) remote control sensor is located on the front of the projector. The remote control must be held at an angle within 30 degrees perpendicular to the projector's IR remote control sensor to function correctly. The distance between the remote control and the sensor should not exceed 7 meters (~ 23 feet).

Make sure that there are no obstacles between the remote control and the IR sensor on the projector that might obstruct the infra-red beam.

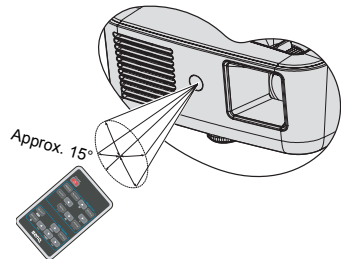

Replacing the remote control battery

1. Pull out the battery holder.

 **Please follow the illustrated instructions. Push and hold the locking arm while pulling out the battery holder.**

2. Insert the new battery in the holder. Note the positive polarity should face outward.
3. Push the holder into the remote control.



- **Avoid excessive heat and humidity.**
- **There may be battery damage if the battery is incorrectly replaced.**
- **Replace only with the same or equivalent type recommended by the battery manufacturer.**
- **Dispose of the used battery according to the battery manufacturer's instructions.**
- **Never throw a battery into a fire. There may be danger of an explosion.**
- **If the battery is dead or if you will not be using the remote control for a long time, remove the battery to prevent damage to the remote control from possible battery leakage.**

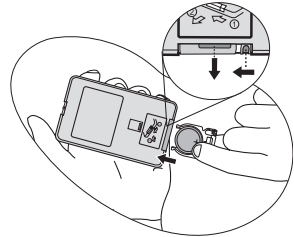

Positioning your projector

Obtaining a preferred projected image size

The distance from the projector lens to the screen, the zoom setting (if available), and the video format each factors in the projected image size.

4:3 is the native aspect ratio of this projector. To be able to project a complete 16:9 (widescreen) aspect ratio image, the projector can resize and scale a widescreen image to the projector's native aspect width. This will result in a proportionally smaller height equivalent to 75% of the projector's native aspect height.

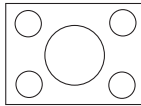

4:3 aspect image in a 4:3 aspect display area

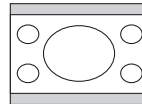

16:9 aspect image scaled to a 4:3 aspect display area

Thus, a 16:9 aspect image will not utilize 25% of the height of a 4:3 aspect image displayed by this projector. This will be seen as darkened (unlit) bars along the top and bottom (vertical 12.5% height respectively) of the 4:3 projection display area whenever displaying a scaled 16:9 aspect image in the vertical center of the 4:3 projection display area.

The projector should always be placed horizontally level (like flat on a table), and positioned directly perpendicular (90° right-angle square) to the horizontal center of the screen. This prevents image distortion caused by angled projections (or projecting onto angled surfaces).

The modern digital projector does not project directly forward (like older style reel-to-reel film projectors did). Instead, digital projectors are designed to project at a slightly upward angle above the horizontal plane of the projector. This is so that they can be readily placed on a table and will project forward and upwards onto a screen positioned so that the bottom edge of the screen is above the level of the table (and everyone in the room can see the screen).

If the projector is mounted on a ceiling, it must be mounted upside-down so that it projects at a slightly downward angle.

You can see from the diagram on page 14, that this type of projection causes the bottom edge of the projected image to be vertically offset from the horizontal plane of the projector. When ceiling mounted, this refers to the top edge of the projected image.

If the projector is positioned further away from the screen, the projected image size increases, and the vertical offset also increases proportionately.

When determining the position of the screen and projector, you will need to account for both the projected image size and the vertical offset dimension, which are directly proportional to the projection distance.

BenQ has provided a table of 4:3-aspect-ratio screen sizes to assist you in determining the ideal location for your projector. Refer to "[Projection dimensions](#)" on page 14 depending on the projector you are using. There are two dimensions to consider, the perpendicular horizontal distance from the center of the screen (projection distance), and the vertical offset height of the projector from the horizontal edge of the screen (offset).

Projection dimensions

Refer to "[Dimensions](#)" on page 56 for the center of lens dimensions of this projector before calculating the appropriate position.

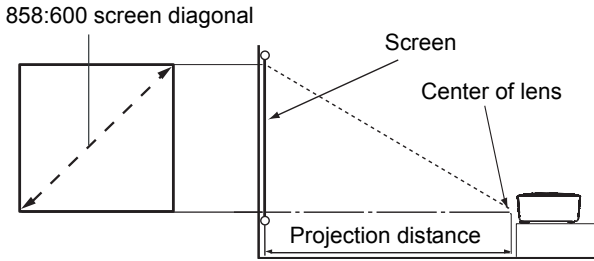

858:600 screen diagonal			Recommended projection distance from screen in mm
Feet	Inches	mm	Average
1.25	15	381	600
2.50	30	762	1200
3.75	45	1143	1800
5.00	60	1524	2400
6.67	80	2032	3200

 There is 3% tolerance among these numbers due to optical component variations. BenQ recommends that if you intend to permanently install the projector, you should physically test the projection size and distance using the actual projector in situ before you permanently install it, so as to make allowance for this projector's optical characteristics. This will help you determine the exact mounting position so that it best suits your installation location.

Connection

When connecting a signal source to the projector, be sure to:

1. Turn all equipment off before making any connections.
2. Use the correct signal cables for each source.
3. Ensure the cables are firmly inserted.

 In the connections shown below, some cables may not be included with the projector (see "Shipping contents" on page 8). They are commercially available from electronics stores.

Connecting a computer

The projector provides a VGA input socket that allows you to connect it to both IBM® compatibles and Macintosh® computers. A Mac adapter is needed if you are connecting legacy version Macintosh computers.

To connect the projector to a notebook or desktop computer:

1. Take the supplied multi-input cable and connect one end to the D-Sub output socket of the computer.
2. Connect the other end of the multi-input cable to the multi-input socket on the projector.
3. If you wish to make use of the projector speaker, take a suitable audio cable and connect one end of the cable to the audio output socket of the computer, and the other end to the audio input sockets of the multi-input cable.

The final connection path should be like that shown in the following diagram:

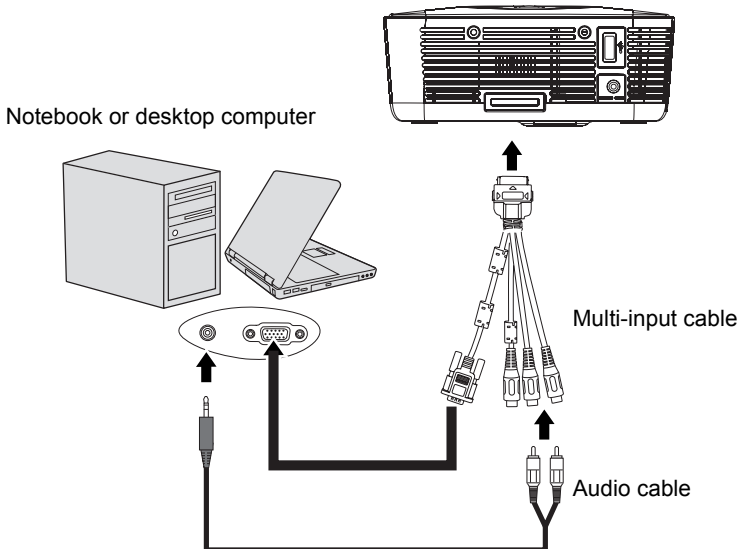

 Many notebooks do not turn on their external video ports when connected to a projector. Usually a key combo like FN + F3 or CRT/LCD key turns the external display on/off. Locate a function key labeled CRT/LCD or a function key with a monitor symbol on the notebook. Press FN and the labeled function key simultaneously. Refer to your notebook's documentation to find your notebook's key combination.

Connecting Video source devices

You can connect your projector to various Video source devices that provide any one of the following output sockets:

- Component Video
- Video (composite)

You need only connect the projector to a Video source device using just one of the above connecting methods, however each provides a different level of video quality. The method you choose will most likely depend upon the availability of matching terminals on both the projector and the Video source device as described below:

Best video quality

The best available video connection method is Component Video (not to be confused with composite Video). Digital TV tuner and DVD players output Component Video natively, so if available on your devices, this should be your connection method of choice in preference to (composite) Video.

See "[Connecting a Component Video source device](#)" on page 17 for how to connect the projector to a component video device.

Least video quality

Composite Video is an analog video and will result in a perfectly acceptable, but less than optimal result from your projector, being the least video quality of the available methods described here.

See "[Connecting a composite Video source device](#)" on page 18 for how to connect the projector to a composite Video device.

Connecting a Component Video source device

Examine your Video source device to determine if it has a set of unused Component Video output sockets available:

- If so, you can continue with this procedure.
- If not, you will need to reassess which method you can use to connect to the device.

To connect the projector to a Component Video source device:

1. Take a Component Video to VGA (D-Sub) adaptor cable and connect the end with 3 RCA type connectors to the Component Video output sockets of the Video source device. Match the color of the plugs to the color of the sockets; green to green, blue to blue, and red to red.
2. Connect the other end of the Component Video to VGA (D-Sub) adaptor cable (with a D-Sub type connector) to the multi-input cable.
3. Connect the multi-input cable to the multi-input socket on the projector.
4. If you wish to make use of the projector speaker, take a suitable audio cable and connect one end of the cable to the audio output sockets of the Video source device, and the other end to the audio input sockets of the multi-input cable.

The final connection path should be like that shown in the following diagram:

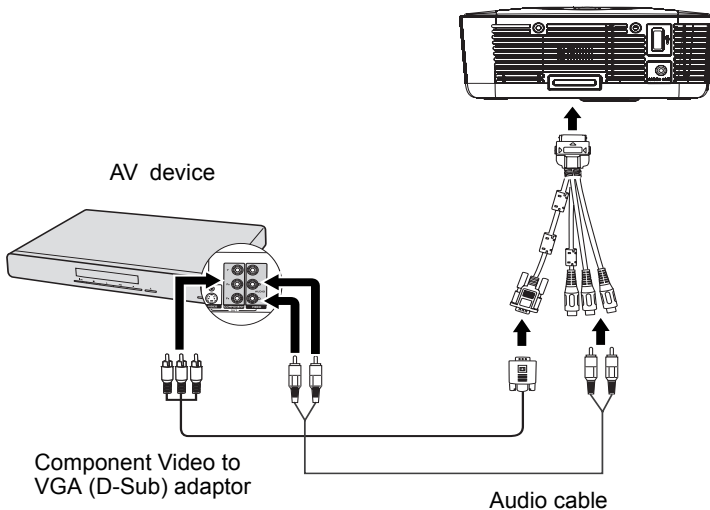

- ☞ If the selected video image is not displayed after the projector is turned on and the correct video source has been selected, check that the Video source device is turned on and operating correctly. Also check that the signal cables have been connected correctly.
- When AUDIO OUT is connected with the earphone or external speaker, the sound will not come out from the projector speaker.
- No sound will come out from the speaker or AUDIO OUT if video signals are not input. Besides, the sound cannot be adjusted either.

Connecting a composite Video source device

Examine your Video source device to determine if it has a set of unused composite Video output sockets available:

- If so, you can continue with this procedure.
- If not, you will need to reassess which method you can use to connect to the device.

To connect the projector to a composite Video source device:

1. Take a Video cable and connect one end to the composite Video output socket of the Video source device.
2. Connect the other end to the Video input socket to the multi-input cable.
3. If you wish to make use of the projector speaker, take a suitable audio cable and connect one end of the cable to the audio output sockets of the Video source device, and the other end to the audio input sockets of the multi-input cable.

The final connection path should be like that shown in the following diagram:

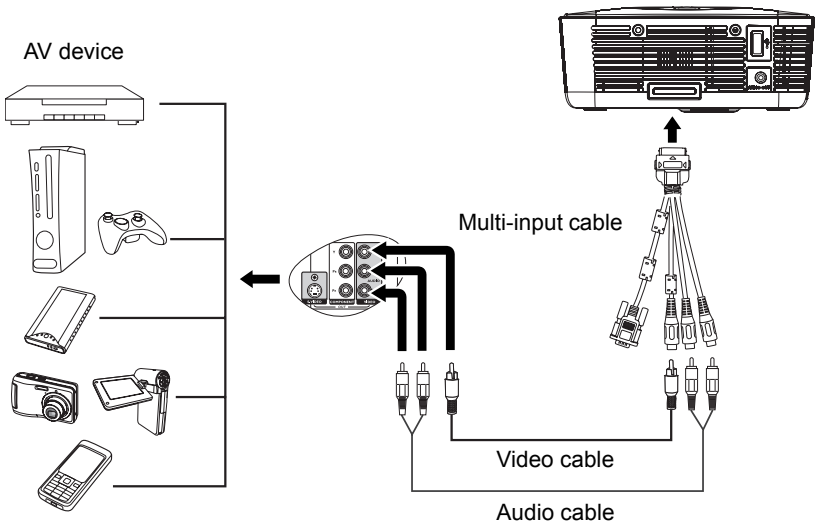

- ☞ • If the selected video image is not displayed after the projector is turned on and the correct video source has been selected, check that the Video source device is turned on and operating correctly. Also check that the signal cables have been connected correctly.
- You need only connect to this device using a composite Video connection if Component Video input is unavailable for use. See "[Connecting Video source devices](#)" on page 16 for details.

Connecting a USB Reader source device

The USB Reader function supports a mass storage device only. Examine your source device if it is a USB memory stick or portable 2.5" hard disk drive.

To connect the projector to a USB Reader source device:

1. Connect a USB Reader source device to the USB slot on the projector.
2. If you wish to make use of a speaker or other audio input equipment, take a suitable audio cable and connect one end to the audio input socket of the speaker, the other end to the **AUDIO OUT** socket of the projector. When the audio cable is connected to the **AUDIO OUT** terminal, the speaker output is muted.

The final connection path should be like that shown in the following diagram:

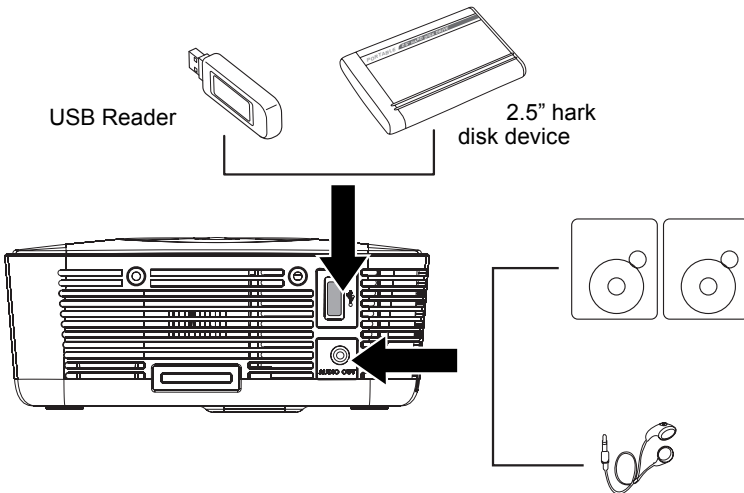

- If the USB Reader main screen is not displayed after the projector is turned on. Press **SOURCE** on the projector or remote control and select USB Reader after a source selection bar displays. See "[Presenting From a USB Reader](#)" on page 42 for details.
- The AUDIO OUT socket on the projector supports USB Reader function only.
- If you are using a 2.5" portable hard disk device, make sure that the file system is FAT32/ FAT16 and the files are saved in primary partition.

Connecting an iPod Dock device (Optional Accessory)

Read this chapter if the model you purchased is included with iPod Dock.

To connect the projector to an iPod Dock source device

1. Dock your iPod to fit the iPod connector.
2. Connect the iPod Dock cable into the multi-input socket on the projector.

The final connection path should be like that shown in the following diagram:

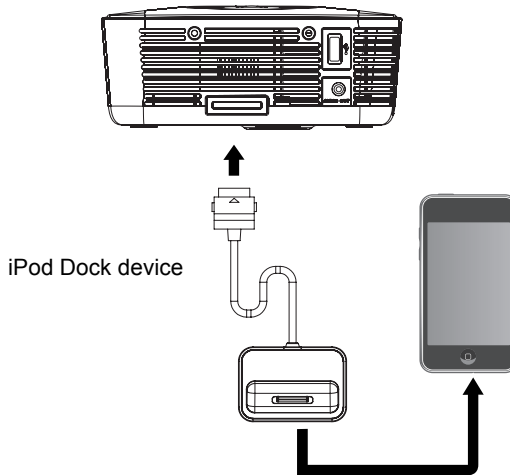

 • See ["Projection with iPod Dock \(Optional Accessory\)"](#) on page 51 for details.

Operation

Starting up the projector

1. Plug the AC adapter into the DC IN socket of the projector.
2. Plug one end of the power cord into the AC adapter.
3. Plug the other end of the power cord into a wall socket. Turn on the wall socket switch (where fitted). Check that the **Power LED indicator** on the projector flashes blue and **Ring LED indicator** lights blue after power has been applied.

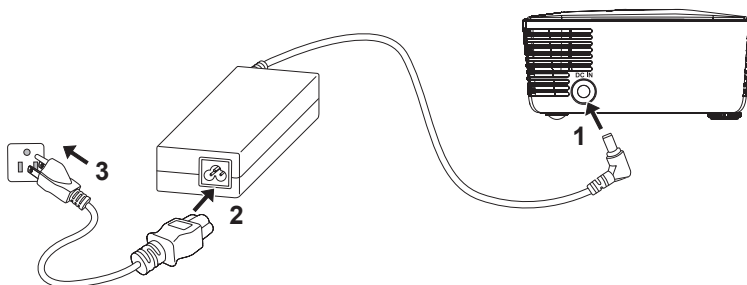

4. Press **Power** on the projector or remote control to start the projector. The **Power, Ring and Key LED indicators** light blue when the projector is on.

The start up procedure takes several seconds. In the later stage of start up, a startup logo is projected.

(If necessary) Rotate the focus ring to adjust the image clearness.

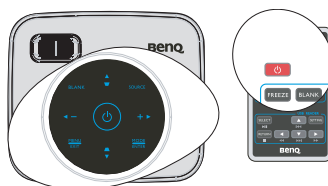

ⓘ If the projector is still hot from previous activity, it will run the cooling fan for approximately 20 seconds before energizing the lamp.

5. If you are prompted for a password, press the arrow keys to enter a six digit password. See "[Utilizing the password function](#)" on page 23 for details.
6. Switch all of the connected equipment on.
7. The projector will start to search for input signals. The current input signal being scanned displays in the upper left corner of the screen. If the projector doesn't detect a valid signal, the message '**No Signal**' will continue displaying until an input signal is found.

You can also press **SOURCE** on the projector or remote control to select your desired input signal. See "[Switching input signal](#)" on page 25 for details.

ⓘ If the frequency/resolution of the input signal exceeds the projector's operating range, you will see the message '**Out of Range**' displayed on a blank screen. Please change to an input signal which is compatible with the projector's resolution or set the input signal to a lower setting. See "[Timing chart](#)" on page 56 for details.

Using the menus

The projector is equipped with On-Screen Display (OSD) menus for making various adjustments and settings.

Below is the overview of the OSD menu.



To use the OSD menus, please set them to your familiar language first.

1. Press **MENU/EXIT** on the projector or remote control to turn the OSD menu on.
3. Highlight **Language** and press **◀/▶** to select a preferred language.



2. Use **◀/▶** to highlight the **SYSTEM SETUP: Basic** menu.
4. Press **MENU/EXIT** twice* on the projector or remote control to leave and save the settings.



***The first press leads you back to the main menu and the second press closes the OSD menu.**

Utilizing the password function

For security purposes and to help prevent unauthorized use, the projector includes an option for setting up password security. The password can be set through the On-Screen Display (OSD) menu. For details of the OSD menu operation, please refer to "Using the menus" on page 22.

You will be inconvenienced if you activate the power-on lock functionality and subsequently forget the password. Print out this manual (if necessary) and write the password you used in this manual, and keep the manual in a safe place for later recall.

Setting a password

Once a password has been set, the projector cannot be used unless the correct password is entered every time the projector is started.

1. Open the OSD menu and go to the **SYSTEM SETUP: Advanced > Security Settings** menu. Press **MODE/ENTER**. The **Security Settings** page displays.
2. Highlight **Power on lock** and select **On** by pressing **◀/▶**.
3. As pictured to the right, the four arrow keys (**▲**, **▶**, **▼**, **◀**) respectively represent 4 digits (1, 2, 3, 4). According to the password you desire to set, press the arrow keys to enter six digits for the password.
4. Confirm the new password by re-entering the new password.
Once the password is set, the OSD menu returns to the **Security Settings** page.

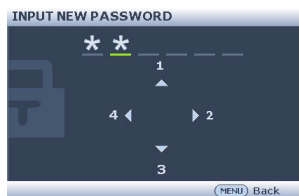

The digits being input will display as asterisks on-screen. Write your selected password down here in this manual in advance or right after the password is entered so that it is available to you should you ever forget it.

Password: _ _ _ _ _

Keep this manual in a safe place.

5. To leave the OSD menu, press **MENU/EXIT**.

If you forget the password

If the password function is activated, you will be asked to enter the six-digit password every time you turn on the projector. If you enter the wrong password, the password error message as pictured to the right displays lasting for three seconds, and the message '**INPUT PASSWORD**' follows. You can retry by entering another six-digit password, or if you did not record the password in this manual, and you absolutely do not remember it, you can use the password recall procedure. See "Entering the password recall procedure" on page 24 for details.

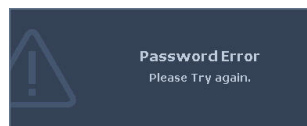

If you enter an incorrect password 5 times in succession, the projector will automatically shut down in a short time.

Entering the password recall procedure

1. Press and hold **AUTO** on the remote control for 3 seconds. The projector will display a coded number on the screen.
2. Write down the number and turn off your projector.
3. Seek help from the local BenQ service center to decode the number. You may be required to provide proof of purchase documentation to verify that you are an authorized user of the projector.

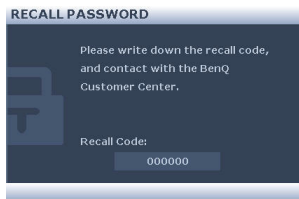

Changing the password

1. Open the OSD menu and go to the **SYSTEM SETUP: Advanced > Security Settings > Change password** menu.
2. Press **MODE/ENTER**. The message 'INPUT CURRENT PASSWORD' displays.
3. Enter the old password.
 - If the password is correct, another message 'INPUT NEW PASSWORD' displays.
 - If the password is incorrect, the password error message displays lasting for three seconds, and the message 'INPUT CURRENT PASSWORD' displays for your retry. You can press **MENU/EXIT** to cancel the change or try another password.
4. Enter a new password.

 **The digits being input will display as asterisks on-screen. Write your selected password down here in this manual in advance or right after the password is entered so that it is available to you should you ever forget it.**

Password: _____

Keep this manual in a safe place.

5. Confirm the new password by re-entering the new password.
6. You have successfully assigned a new password to the projector. Remember to enter the new password next time the projector is started.
7. To leave the OSD menu, press **MENU/EXIT**.

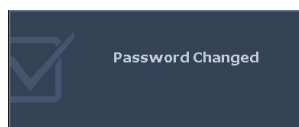

Disabling the password function

To disable password protection, go back to the **SYSTEM SETUP: Advanced > Security Settings > Power on lock** menu after opening the OSD menu system. Select **Off** by pressing **◀ / ▶**. The message 'INPUT PASSWORD' displays. Enter the current password.

- If the password is correct, the OSD menu returns to the **Security Settings** page with 'Off' shown in the row of **Power on lock**. You will not have to enter the password next time you turn on the projector.
- If the password is incorrect, the password error message displays lasting for three seconds, and the message 'INPUT PASSWORD' displays for your retry. You can press **MENU/EXIT** to cancel the change or try another password.

 **Though the password function is disabled, you need to keep the old password in hand should you ever need to re-activate the password function by entering the old password.**

Switching input signal

The projector can be connected to multiple devices at the same time. However, it can only display one full screen at a time.

Be sure the **Quick Auto Search** function in the **SOURCE** menu is **On** (which is the default of this projector) if you want the projector to automatically search for the signals.

You can also manually cycle through the available input signals.

1. Press **SOURCE** on the projector or remote control. A source selection bar displays.
2. Press **▲ / ▼** until your desired signal is selected and press **MODE/ENTER**.
Once detected, the selected source information will display on the screen for seconds. If there is multiple equipment connected to the projector, repeat steps 1-2 to search for another signal.

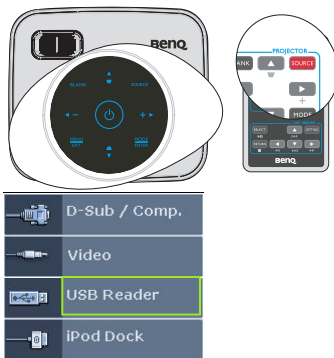

- **The brightness level of the projected image will change accordingly when you switch between different input signals. Data (graphic) "PC" presentations using mostly static images are generally brighter than "Video" using mostly moving images (movies).**
- **The input signal type effects the options available for the Picture Mode. See "Selecting a picture mode" on page 28 for details.**
- **The native display resolution of this projector is in a 4:3 aspect ratio. For best display picture results, you should select and use an input signal which outputs at this resolution. Any other resolutions will be scaled by the projector depending upon the 'aspect ratio' setting, which may cause some image distortion or loss of picture clarity. See "Selecting the aspect ratio" on page 27 for details.**

Adjusting the projected image

Adjusting the image height

The projector is equipped with 1 adjuster foot. This adjuster changes the image height. To adjust the projector:

1. Screw the adjuster foot to adjust the image height.

To retract the foot, screw the adjuster foot in a reverse direction.

If the projector is not placed on a flat surface or the screen and the projector are not perpendicular to each other, the projected image becomes trapezoidal. To correct this situation, see "[Correcting keystone](#)" on page 26 for details.

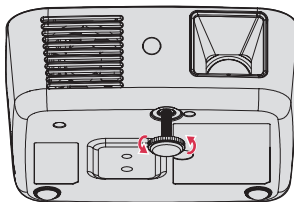

- **Do not look into the lens while the lamp is on. The strong light from the lamp may cause damage to your eyes.**
- **Be careful when you screw the adjuster foot as it is close to the exhaust vent where hot air comes from.**

Auto-adjusting the image

In some cases, you may need to optimize the picture quality.

- Using the remote control

Press **AUTO**.

- Using the OSD menu

1. Press **MENU/EXIT** and then press ◀ / ▶ until the **DISPLAY** menu is highlighted.
2. Press ▼ to highlight **Auto** and press **MODE/ENTER**.

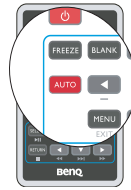

Within 3 seconds, the built-in Intelligent Auto

Adjustment function will re-adjust the values of Frequency and Clock to provide the best picture quality.

The current source information will be displayed in the upper left corner of the screen for 3 seconds.



- **The screen will be blank while AUTO is functioning.**
- **This function is only available when PC signal (analog RGB) is selected.**

Fine-tuning the image clarity

1. Rotate the focus ring to sharpen the image.

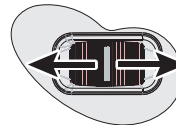

Correcting keystone

Keystoning refers to the situation where the projected image is noticeably wider at either the top or bottom. It occurs when the projector is not perpendicular to the screen.

To correct this, besides adjusting the height of the projector, you will need to manually correct it following one of these steps.

- Using the remote control

Press ◻ / ◼ on the projector or remote control to display the Keystone correction page. Press ◻ to correct keystone at the top of the image. Press ◼ to correct keystone at the bottom of the image.

- Using the OSD menu

1. Press **MENU/EXIT** and then press ◀ / ▶ until the **DISPLAY** menu is highlighted.
2. Press ▼ to highlight **Keystone** and press **MODE/ENTER**. The **Keystone** correction page displays.
3. Press ◻ to correct keystone at the top of the image or press ◼ to correct keystone at the bottom of the image.



Press ◻ / ▲.

Press ◼ / ▼.

Magnifying and searching for details

If you need to find the details on the projected picture, magnify the picture. Use the direction arrow keys for navigating the picture.

1. Press **MENU/EXIT** and then press **◀ / ▶** until the **DISPLAY** menu is highlighted.
2. Press **▼** to highlight **Digital Zoom** and press **MODE/ENTER**. The Zoom bar displays.
3. Press **▲** on the projector repeatedly to magnify the picture to a desired size.
4. To navigate the picture, press **MODE/ENTER** to switch to the panning mode and press the directional arrows (**▲**, **▼**, **◀**, **▶**) to navigate the picture.
5. Use the directional arrows (**▲**, **▼**, **◀**, **▶**) on the projector or remote control to navigate the picture.
6. To reduce size of the picture, press **MODE/ENTER** to switch back to the zoom in/out functionality, and press **AUTO** to restore the picture to its original size. You can also press **▼** repeatedly until it is restored to the original size.

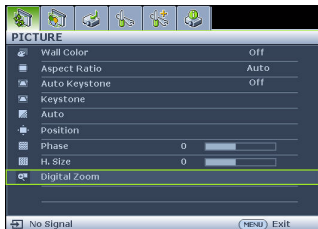

 **The picture can only be navigated after the picture is magnified. You can further magnify the picture while searching for details.**

Selecting the aspect ratio

The 'aspect ratio' is the ratio of the image width to the image height. Most analog TV and computers are in 4:3 ratio, which is the default for this projector, and digital TV and DVDs are usually in 16:9 ratio.

With the advent of digital signal processing, digital display devices like this projector can dynamically stretch and scale the image output to a different aspect than that of the image input signal.

To change the projected image ratio (no matter what aspect the source is):

1. Press **MENU/EXIT** and then press **◀ / ▶** until the **DISPLAY** menu is highlighted.
2. Press **▼** to highlight **Aspect Ratio**.
3. Press **◀ / ▶** to select an aspect ratio to suit the format of the video signal and your display requirements.

About the aspect ratio

 **In the pictures below, the black portions are inactive areas and the white portions are active areas. OSD menus can be displayed on those unused black areas.**

1. **Auto:** Scales an image proportionally to fit the projector's native resolution in its horizontal width. This is suitable for the incoming image which is neither in 4:3 nor 16:9 and you want to make most use of the screen without altering the image's aspect ratio.

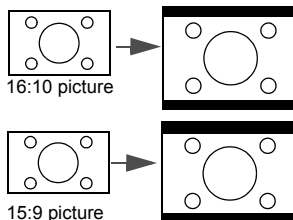

2. **Real:** The image is projected as its original resolution, and resized to fit within the display area. For input signals with lower resolutions, the projected image will display smaller than if resized to full screen. You could adjust the zoom setting or move the projector towards the screen to increase the image size if necessary. You may also need to refocus the projector after making these adjustments.
3. **Full Screen:** Any types of resolution always fill the whole screen.
4. **4:3:** Scales an image so that it is displayed in the center of the screen with a 4:3 aspect ratio. This is most suitable for 4:3 images like computer monitors, standard definition TV and 4:3 aspect DVD movies, as it displays them without aspect alteration.
5. **16:9:** Scales an image so that it is displayed in the center of the screen with a 16:9 aspect ratio. This is most suitable for images which are already in a 16:9 aspect, like high definition TV, as it displays them without aspect alteration.

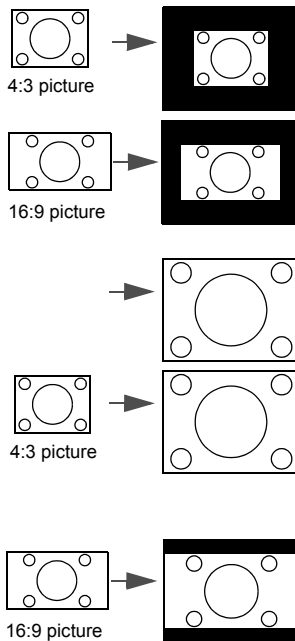

Optimizing the image

Selecting a picture mode

The projector is preset with several predefined picture modes so that you can choose one to suit your operating environment and input signal picture type.

To select an operation mode that suits your need, you can follow one of the following steps.

- Press **MODE/ENTER** on the remote control or projector repeatedly until your desired mode is selected.
- Go to the **PICTURE > Picture Mode** menu and press **◀/▶** to select a desired mode.

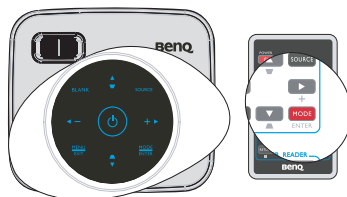

Picture modes for different types of signals

The picture modes available for different types of signals are listed below.

1. **Brightness mode (Default):** Maximizes the brightness of the projected image. This mode is suitable for environments where extra-high brightness is required, such as using the projector in well lit rooms.
2. **PC mode:** Is designed for presentations. The brightness is emphasized in this mode to match PC and notebook coloring.

3. **Photo mode:** Maximizes the purity of RGB colors to provide true-to-life images regardless of brightness setting. It is most suitable for viewing photos taken with an sRGB compatible and properly calibrated camera, and for viewing PC graphic and drawing applications such as AutoCAD.
4. **Movie mode:** Is appropriate for playing colorful movies, video clips from digital cameras or DVs through the PC input for best viewing in a blackened (little light) environment.
5. **User mode:** Recalls the settings customized based on the current available picture modes. See "[Setting the User mode](#)" on page 29 for details.

Setting the User mode

There are two user-definable modes if the current available picture modes are not suitable for your need. You can use one of the picture modes (except the **User**) as a starting point and customize the settings.

1. Press **MENU/EXIT** to open the On-Screen Display (OSD) menu.
2. Go to the **PICTURE > Picture Mode** menu.
3. Press **◀/▶** to select **User**.
4. Press **▼** to highlight **Reference Mode**.



This function is only available when User mode is selected up in the Picture Mode sub-menu item.

5. Press **◀/▶** to select a picture mode that is closest to your need.
6. Press **▼** to select a sub-menu item to be changed and adjust the value with **◀/▶**. See "[Fine-tuning the image quality in user modes](#)" below for details.
7. When all settings have been done, highlight **Save Settings** and press **MODE/ENTER** to store the settings.
8. The confirmation message '**Setting Saved**' displays.

Using Wall Color

In the situation where you are projecting onto a colored surface such as a painted wall which may not be white, the **Wall Color** feature can help correct the projected picture's color to prevent possible color difference between the source and projected pictures.

To use this function, go to the **DISPLAY > Wall Color** menu and press ◀/▶ to select a color which is the closest to the color of the projection surface. There are several precalibrated colors to choose from: **Light Yellow**, **Pink**, **Light Green**, **Blue**, and **Blackboard**.

Fine-tuning the image quality in user modes

According to the detected signal type, there are some user-definable functions available when **User 1** or **User 2** mode is selected. You can make adjustments to these functions based on your needs.

Adjusting Brightness

Highlight **Brightness** in the **PICTURE** menu and adjust the values by pressing ◀/▶ on the projector or remote control.

The higher the value, the brighter the image. And lower the setting, darker the image. Adjust this control so the black areas of the image appear just as black and that detail in the dark areas is visible.



Adjusting Contrast

Highlight **Contrast** in the **PICTURE** menu and adjust the values by pressing ◀/▶ on the projector or remote control.

The higher the value, the greater the contrast. Use this to set the peak white level after you have previously adjusted the **Brightness** setting to suit your selected input and viewing environment.



Adjusting Color

Highlight **Color** in the **PICTURE** menu and adjust the values by pressing ◀/▶ on the projector or remote control.

Lower setting produces less saturated colors. If the setting is too high, colors on the image will be overpowering, which makes the image unrealistic.

Adjusting Tint

Highlight **Tint** in the **PICTURE** menu and adjust the values by pressing ◀/▶ on the projector or remote control.

The higher the value, the more reddish the picture becomes. The lower the value, the more greenish the picture becomes.

Adjusting Sharpness

Highlight **Sharpness** in the **PICTURE** menu and adjust the values by pressing ◀/▶ on the projector or remote control.

The higher the value, the sharper the picture becomes. The lower the value, the softer the picture becomes.

Selecting a Color Temperature

Highlight **Color Temperature** in the **PICTURE** menu and adjust the values by pressing ◀/▶ on the projector or remote control.

The options available for color temperature* settings vary according to the signal type selected.

1. **T1:** With the highest color temperature, T1 makes the image appear the most bluish white than other settings.
2. **T2:** Makes images appear bluish white.
3. **T3:** Maintains normal colorings for white.

***About color temperatures:**

There are many different shades that are considered to be "white" for various purposes. One of the common methods of representing white color is known as the "color temperature". A white color with a low color temperature appears to be reddish white. A white color with a high color temperature appears to have more blue in it.

Hiding the image

In order to draw the audience's full attention to the presenter, you can use **BLANK** on the projector or remote control to hide the screen image. Press any key on the projector or remote control to restore the image. The word '**BLANK**' appears at the lower right corner of the screen while the image is hidden.

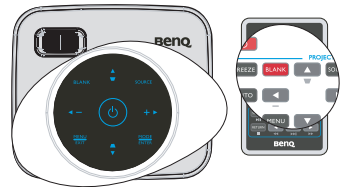

You can set the blank time in the **SYSTEM SETUP: Basic > Blank Timer** menu to let the projector return the image automatically after a period of time when there is no action taken on the blank screen.

 Once **BLANK** is pressed, the projector enters **Economic mode** automatically.

 Do not block the projection lens from projecting as this could cause the blocking object to become heated and deformed or even cause a fire.

Freezing the image

Press **FREEZE** on the remote control to freeze the image. The word '**FREEZE**' will display in the upper left corner of the screen. To release the function, press any key on the projector or remote control.

Even if an image is frozen on the screen, the pictures are running on the video or other device. If the connected devices have active audio output, you will still hear the audio even though the image is frozen on screen.

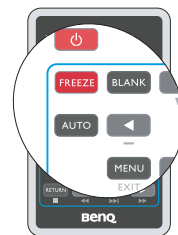

Operating in a high altitude environment

We recommend you use the **High Altitude Mode** when your environment is between 1500 m –4000 m above sea level, and temperature is between 5°C–35°C.

 **Do not use the High Altitude Mode if your altitude is between 0 m and 1500 m and temperature is between 5°C and 35°C. The projector will be over cooled, if you turn the mode on under such a condition.**

To activate the **High Altitude Mode**:

1. Press **MENU/EXIT** and then press **◀ / ▶** until the **SYSTEM SETUP: Advanced** menu is highlighted.
2. Press **▼** to highlight **High Altitude Mode** and press **◀ / ▶** to select **On**. A confirmation message displays.
3. Highlight **Yes** and press **MODE/ENTER**.

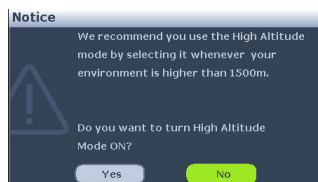

Operation under "**High Altitude Mode**" may cause a higher decibel operating noise level because of increased fan speed necessary to improve overall system cooling and performance.

If you use this projector under other extreme conditions excluding the above, it may display auto shut-down symptoms, which is designed to protect your projector from over-heating. In cases like this, you should switch to High Altitude mode to solve these symptoms. However, this is not to state that this projector can operate under any and all harsh or extreme conditions.

Adjusting the sound

The sound adjustments made as below will have an effect on the projector speaker(s). Be sure you have made a correct connection to the projector audio input. See "[Connection](#)" on [page 15](#) for how the audio input is connected.

Muting the sound

To temporarily turn off the sound:

1. Press **MENU/EXIT** and then press **◀ / ▶** until the **SYSTEM SETUP: Advanced** menu is highlighted.
2. Press **▼** to highlight **Audio Settings** and press **MODE/ENTER**. The **Audio Settings page** displays.
3. Highlight **Mute** and press **◀ / ▶** to select **On**.



Adjusting the sound level

To adjust the sound level, press **◀ / ▶** :

1. Repeat steps 1-2 above.
2. Press to highlight **Volume** and press **◀ / ▶** to select a desired sound level.

Personalizing the projector menu display

The On-Screen Display (OSD) menus can be set according to your preferences. The following settings do not affect the projection settings, operation, or performance.

- **Menu display time** in the **SYSTEM SETUP: Advanced > Menu Settings** menu sets the length of time the OSD will remain active after your last key press. The time length ranges from 5 to 30 seconds in 5-second increments. Use ◀/▶ to select a suitable time frame.
- **Menu position** in the **SYSTEM SETUP: Advanced > Menu Settings** menu sets the OSD position in five locations. Use ◀/▶ to select a preferred position.
- **Language** in the **SYSTEM SETUP: Basic** menu sets your familiar language for the OSD menus. Use ◀/▶ to select your language.
- **Splash Screen** in the **SYSTEM SETUP: Basic** menu sets a preferred logo screen to be displayed during projector start-up. Use ◀/▶ to select a screen.

Shutting down the projector

1. Press **Power** and a confirmation message displays prompting you.
If you don't respond in a few seconds, the message will disappear.
2. Press **Power** a second time. The **Power LED indicator** flashes blue fast and **Ring LED indicator** lights blue, the projection lamp shuts down, and the fans will continue to run for approximately 90 seconds to cool down the projector.
3. Once the cooling process finishes, the **Power LED indicator** flashes blue slowly and **Ring LED indicator** lights blue and fans stop.
4. Disconnect the power cord from the wall socket if the projector will not be used in an extended period of time.

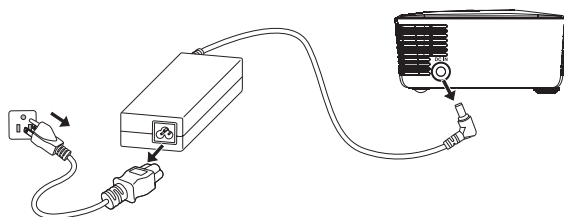
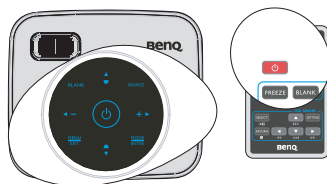

- ☞ **To protect the lamp, the projector will not respond to any commands during the cooling process.**
- **Do not unplug the power cord before the projector shutdown sequence is complete or during the 90-second cooling down process.**
- **If the projector is not properly shut down, to protect the lamp, when you attempt to re-start the projector, the fans will run for a few minutes to cool down. Press Power again to start the projector after the fans stop and the Power LED indicator flashes blue slowly and Ring LED indicator lights blue.**

Projector menu operation

Please note that the on-screen display (OSD) menus vary according to the signal type selected.

Simple menu system

Main menu	Sub-menu	Options
Wall Color		Off/Light/Yellow/Pink/ LightGreen/Blue/Blackboard
Aspect Ratio		Full Screen/4:3/16:9/Auto/Real
Picture Mode		Brightest/PC/Movie/Photo/ User
Language		English/Français/Deutsch/ Italiano/Español/Русский/ 繁體中文/ 简体中文/ 日本語/ 한국어/ Svenska/ Nederlands/ Türkçe/ Čeština/ Português/ ไทย/ Polski
Quick Auto Search		On/Off
Projector Position		Front Table/Rear Table/Rear/ Ceiling/Front Ceiling
Menu Settings	Menu display time	5 sec/10 sec/15 sec/20 sec/25 sec/30 sec
	Menu position	Center/Top-Left/Top-Right/ Bottom-Right/Bottom-Left
Security Settings	Change password	
	Change Security Settings <ul style="list-style-type: none"> Power on Lock 	On/Off
Information	FAQ-Image and Installation	
	FAQ-Features and Service	
	Current System Status <ul style="list-style-type: none"> Source Picture Mode Resolution Color System System Hour FW Version 	
	Reset All Settings	
Menu Type		Simple/Complete



Complete menu system

Main menu	Sub-menu	Options
1. DISPLAY	Wall Color	Off/Light Yellow/Pink/Light Green/Blue/Blackboard
	Aspect Ratio	Full Screen/4:3/16:9/Auto/Real
	Auto Keystone	On/Off
	Keystone	
	Auto	
	Position	
	Phase	
	H. Size	
	Digital Zoom	
2. PICTURE	Picture Mode	Brightest/PC/Movie/Photo/User
	• Reference Mode	Brightest/PC/Movie/Photo/User
	• Brightness	
	• Contrast	
	• Color	
	• Tint	
	• Sharpness	
	• Color Temperature	T1/T2/T3
Save Settings		
3. SOURCE	Quick Auto Search	On/Off
	Test Pattern	On/Off
4. SYSTEM SETUP: Basic	Language	English/Français/Deutsch/Italiano/Español/Русский/繁體中文/简体中文/日本語/ 한국어/Svenska/Nederlands/ Türkçe/Čeština/ Português/ తెలుగు/ Polski
	Projector Position	Front Table/Rear Table/Rear Ceiling/Front Ceiling
	Auto Power Off	Disable/5 min/10 min/15 min/20 min/25 min/30 min
	Blank Timer	Disable/5 min/10 min/15 min/20 min/25 min/30 min
	Sleep Timer	Disable/30 min/1 hr/2 hr/3 hr/4 hr/8 hr/12 hr
	Splash Screen	BenQ/Black/Blue

5. SYSTEM SETUP: Advanced	High Altitude Mode		On/Off	
	Audio Settings	Mute	On/Off	
		Volume		
		Keypad tone	On/Off	
	Menu Settings	Menu display time	5 sec/10 sec/15 sec/20 sec/25 sec/30 sec	
		Menu position	Center/Top-Left/Top-Right/Bottom-Right/Bottom-Left	
	Security Settings	Change password		
		Change Security Settings		
		• Power on Lock		On/Off
	Reset All Settings			
6. INFORMATION	FAQ-Image and Installation			
	FAQ-Features and Service			
	Current System Status			
	<ul style="list-style-type: none"> • Source • Picture Mode • Resolution • Color System • System Hour • FW Version 			

Note that the menu items are available when the projector detects at least one valid signal. If there is no equipment connected to the projector or no signal detected, limited menu items are accessible.

Description of each menu

FUNCTION (default setting/ value)	DESCRIPTION (default setting/value)
Wall Color (Off)	Corrects the projected picture's color when the projection surface is not white. See "Using Wall Color" on page 30 for details.
Aspect Ratio (Auto)	There are four options to set the image's aspect ratio depending on your input signal source. See "Selecting the aspect ratio" on page 27 for details.
Auto Keystone (Auto)	Auto corrects any keystoneing of the image.
Keystone (0)	Corrects any keystoneing of the image. See "Correcting keystone" on page 26 for details.
Auto	Optimizes the picture quality. See "Auto-adjusting the image" on page 26 for details.  This function is only available when PC signal (analog RGB) is selected.
Position	Displays the position adjustment page. To move the projected image, use the directional arrow keys. The values shown on the lower position of the page change with every key press you made until they reach their maximum or minimum.
Phase	Adjusts the clock phase to reduce image distortion.   This function is only available when PC signal (analog RGB) is selected.
H. Size (0)	Adjusts the horizontal width of the image.
Digital Zoom (1.0X)	Magnifies or reduces the projected image. See "Magnifying and searching for details" on page 27 for details.

1. DISPLAY menu

FUNCTION (default setting/ value)	DESCRIPTION (default setting/value)
Picture Mode (Brightest)	Pre-defined picture modes are provided so you can optimize your projector image set-up to suit your program type. See "Selecting a picture mode" on page 28 for details.
Reference Mode (Brightest)	Selects a picture mode that most suits your need for the image quality and further fine-tune the image based on the selections listed on the same page below. See "Setting the User mode" on page 29 for details.
Brightness (50)	Adjusts the brightness of the image. See "Adjusting Brightness" on page 30 for details.
Contrast (0)	Adjusts the degree of difference between dark and light in the image. See "Adjusting Contrast" on page 30 for details.
Color (0)	Adjusts the color saturation level -- the amount of each color in a video image. See "Adjusting Color" on page 30 for details.
Tint (0)	Adjusts the red and green color tones of the image. See "Adjusting Tint" on page 30 for details.  The function is only available when Video with NTSC system is selected.
Sharpness (15)	Adjusts the image to make it look sharper or softer. See "Adjusting Sharpness" on page 30 for details.
Color Temperature (T1)	See "Selecting a Color Temperature" on page 30 for details.
Save Settings	Saves the settings made for User mode.

		FUNCTION (default setting/ value)	DESCRIPTION (default setting/value)
3. SOURCE menu	Quick Auto Search (On)		See " Switching input signal " on page 25 for details.
	Test Pattern (Off)		Selecting On enables the function and the projector displays the grid test pattern. It helps you adjust the image size and focus and check that the projected image is free from distortion.
4. SYSTEM SETUP: Basic menu	Language (English)		Sets the language for the On-Screen Display (OSD) menus. See " Using the menus " on page 22 for details.
	Projector Position (Front Table)		The projector can be installed on a ceiling or behind a screen, or with one or more mirrors.
	Auto Power Off (Disable)		Allows the projector to turn off automatically if no input signal is detected after a set period of time.
	Blank Timer (Disable)		Sets the image blank time when the Blank feature is activated, once elapsed the image will return to the screen. See " Hiding the image " on page 31 for details.
	Sleep Timer (Disable)		Sets the auto-shutdown timer. The timer can be set to a value between 30 minutes and 12 hours.
	Splash Screen (BenQ logo)		Allows you to select which logo screen will display during projector start-up. Three options are available: BenQ logo, Black screen, or Blue screen.

FUNCTION (default setting/ value)	DESCRIPTION (default setting/value)
High Altitude Mode (Off)	A mode for operation in high altitude areas. See " Operating in a high altitude environment " on page 32 for details.
Audio Settings	Mute (Off) Mutes the sound. See " Adjusting the sound " on page 32 for details.
	Volume (8) Adjust the volume level. See " Adjusting the sound " on page 32 for details. Keypad tone Sets the keypad tone.
Menu Settings	Menu display time (15 sec) Sets the length of time the OSD will remain active after your last key press. The range is from 5 to 30 seconds in 5-second increments.
	Menu position (Center) Sets the On-Screen Display (OSD) menu position.
Security Settings	Change password You will be asked to enter the current password before changing to a new one. Change Security Settings Power on Lock (Off) See " Utilizing the password function " on page 23 for details.
Reset All Settings	Returns all settings to the factory preset values.  The following settings will still remain: Position, Phase, H. Size, , User, Language, Projector Position, High Altitude Mode, Security Setting.

5. SYSTEM SETUP:
Advanced menu

FUNCTION (default setting/ value)		DESCRIPTION (default setting/value)
6. INFORMATION menu	FAQ-Image and Installation	Displays possible solutions to problems you may encounter.
	FAQ-Features and Service	
	Current System Status	<p>Source Shows the current signal source.</p> <p>Picture Mode Shows the selected mode in the PICTURE menu.</p> <p>Resolution Shows the native resolution of the input signal.</p> <p>Color System Shows input system format, NTSC, PAL, SECAM, or RGB.</p> <p>System Hour Displays the number of hours the projector system has been used.</p> <p>FW Version Shows current F/W version of the projector.</p>

Presenting From a USB Reader

The projector is equipped with USB Reader features for displaying photos and movies.

Entering USB Reader main screen

1. Connect your USB Reader into the projector.
2. Turn on the projector, if it is not already on. The projector will automatically search for USB Reader signal if the **Quick Auto Search** function in the **SOURCE** menu is **On**. You may also manually select USB Reader signal through the source selection bar.
3. Press **SOURCE** on the projector or remote control. A source selection bar displays.

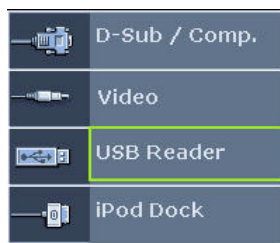
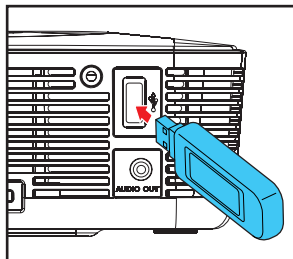

4. Press **▲ / ▼** to select **USB Reader** and press **MODE/ENTER**. Once selected, the USB Reader main screen displays.

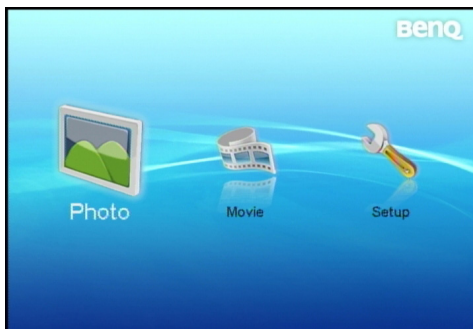

 If you want to operate Projector Menu under USB OSD, please press **MENU/EXIT** for three seconds.

Playing back photos and movies

1. Connect your USB Reader into the projector.
2. Enter USB Reader main screen.
3. Select Photo or Movie folder and press **SELECT/▶II**. The file in the selected folder displays in the screen. Uses **◀◀/▶▶** to play previous or next file. Use **◀◀/▶▶** to allow fast reverse play or fast forward play during playback.

- To stop playback, press **RETURN/■**.

"PC-less" presentations

This feature is ideal for business user to present sheets and graphics.

- Open your PowerPoint file.
- Click "File" and select "Save As".

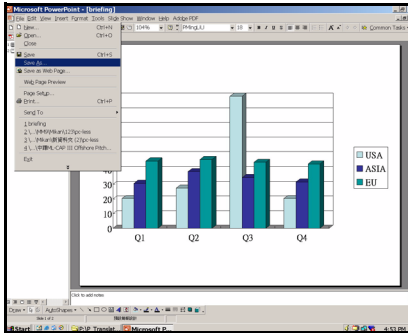

- Save the file in your USB Reader, select "*.jpg" as file type and then click "Save".

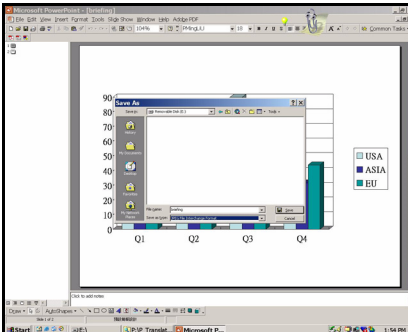

- Insert your USB Reader into the USB Reader slot on the projector.
- Execute "PC-less" presentations from your USB Reader.

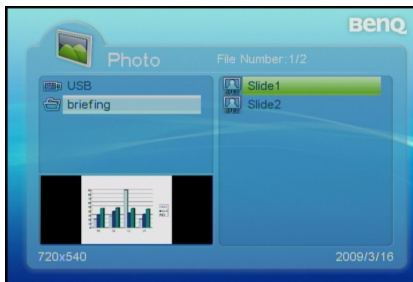

Using USB Reader menus

The Setup Menu from the USB Reader main screen is equipped with On-Screen Display (OSD) menus for making various adjustments and settings.

Below is the overview of the **Photo Setting** menu.

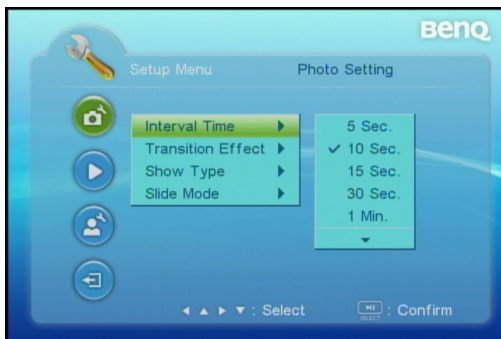

In USB Reader mode, be sure to use keys included in USB READER on the remote control for function control and menu adjustments.

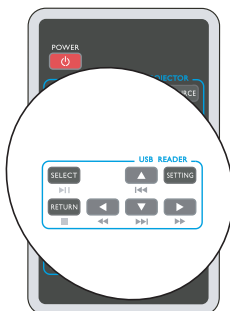

To use USB Reader OSD menus, please set them to your familiar language first.

1. Press **SETTING**.
 - You can also highlight **Setup** and press **SELECT/▶** to enter system settings.



3. Press **▶** to enter sub-menu and press **▼** to highlight **OSD Language**.



2. Use **▲ / ▼** to highlight **Custom Setup** menu.

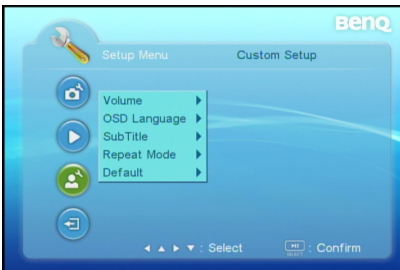

4. Press **▶** to enter options and press **▲ / ▼** to highlight a preferred language.



5. Press **SELECT/▶** to select a preferred language.
6. Press **◀** to return back to main menu.
7. Press **SETTING*** to leave and save the settings.
 - You can also directly press **SETTING** in step 6 to leave and save the settings.



USB Reader menu operation

USB Reader menu system

Please note that the on-screen display (OSD) menus vary according to the signal type selected.

Main menu	Sub-menu	Options
1. Photo Setting	Interval Time	5 Sec./10 Sec./30 Sec./1Min./3 Min./Off
	Transition Effect	No Effect/Blind Vertical/Blind Horizontal/Color Ration Ver/Color Ration Hor/Block 1- 9/ Fade In Fade Out/Random
	Show Type	Fit Screen/Full Screen
	Slide Mode	Normal/Motion
2. Auto Play	Photo	On/Off
	Movie	On/Off
	Volume	0 - 10
3. Custom Setup	OSD Language	English/Deutsch/Svenska/ Polski/繁體中文/简体中文/日本語 * The language options vary depending on regions.
	Subtitle Language	English/Deutsch/Svenska/ Polski/繁體中文/简体中文/日本語 * The language options vary depending on regions.
	Repeat Mode	Off/One/Folder/All
	Default	Read
4. Exit		

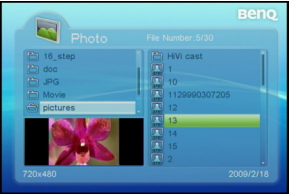
Description of each menu

	FUNCTION (default setting/ value)	DESCRIPTION (default setting/value)
1. Photo Setting menu	Interval Time (10 Sec.)	Sets the length of time for display of each image.
	Transition Effect (No Effect)	Sets the transition effect as images change.
	Show Type (Full Screen)	Selects " Full Screen " display or " Fit Screen " display for photo mode.
	Slide Mode (Normal)	Selects slide playing mode.
2. Auto Play menu	Photo (Off)	<p>Sets to whether to activate the automatic display function after entering the "Photo" mode. If this option is set to "On", then the system will enter "Slide show mode" after you enter "Photo" mode; if it is set to "Off", then the system will enter File Manager mode.</p> 
	Movie (Off)	<p>Sets to whether to initiate the automatic play function after entering "Movie" mode. If this setting is set to "On", the system will automatically play the video after entering "Movie"; if it is set to "Off", then the system will enter File Manager mode.</p> 

3. Custom Setup menu	Volume	Adjusts the volume level.
	OSD Language (English)	Sets the language for USB Reader On-Screen Display (OSD) menus. English/Deutsch/Svenska/ Polski/繁體中文/简体中文/日本語 See " Using USB Reader menus " on page 44 for details. * The language options vary depending on regions.
	Subtitle Language	Sets the character encoding of the languages.
	Repeat Mode	Sets the play repeat mode.
	Default	Returns all settings to the factory preset values.
4. Exit		Returns to USB Reader main screen.

USB Reader support format

	Extension	Detail
Photo	.jpeg	Baseline JPEG WxH = 14592x12288, Up to 179 Mega-pixel Support format: 444/ 440/ 422/ 420/ Grayscale max. file size = 40MB
		Progressive JPEG Up to 4 Mega-pixel Support format: 444/ 440/ 422/ 420/ Grayscale max. file size = 40MB
	.bmp	Up to 20 Mega-pixel Support format: 444/ 440/ 422/ 420/ Grayscale max. file size = 40MB
	.gif	WxH = 14592x12288, Up to 179 Mega-pixel Support format: version 87a/ version 89a (except animation & interlace) max. file size = 40MB
	.tiff	Up to 3200x3200 max. file size = 40MB

	Extension	Video Codec	Audio Codec	Detail
Movie	.dat/ .mpg	MPEG-1/ 2	MPEG layer 1/ 2	NTSC: max. 720x480 @ 30fps PAL: max. 720x576 @ 25 fps
	.vob	MPEG-1/ 2	AC3	NTSC: max. 720x480 @ 30fps PAL: max. 720x576 @ 25 fps
	.avi	XviD/ 3ivX	MPEG layer 1/ 2 uLaw/ aLaw/ PCM (8-bit/ 16-bit)/ AAC LC	NTSC: max. 720x480 @ 30fps PAL: max. 720x576 @ 25 fps
		MS ISO MPEG4	AAC LC	NTSC: max. 720x480 @ 30fps PAL: max. 720x576 @ 25 fps
		Motion JPEG		Baseline JPEG :VGA @ 30fps
	.mp4/ .mov/ .3gp/ .3g2	MPEG-4	MPEG layer 1/ 2 uLaw/ aLaw/ PCM (8-bit/ 16-bit)/ AAC LC	NTSC: max. 720x480 @ 30fps PAL: max. 720x576 @ 25 fps
		Motion JPEG		Baseline JPEG :VGA @ 30fps

	Format	Note
Subtitle	SMI	Text File Format
	SRT	
	SUB	
	ASS	
	SSA	
	PSB	

Projection with iPod Dock (Optional Accessory)

Read this chapter if the model you purchased is included with iPod Dock.

Multimedia base features iPod Dock, which brings your music, videos and photos together.

1. Dock your iPod to fit the iPod connector.
2. Connect the iPod Dock cable into the multi-input socket on the projector.
3. Turn on your iPod and projector.
4. Select your music, videos and photos from your iPod.

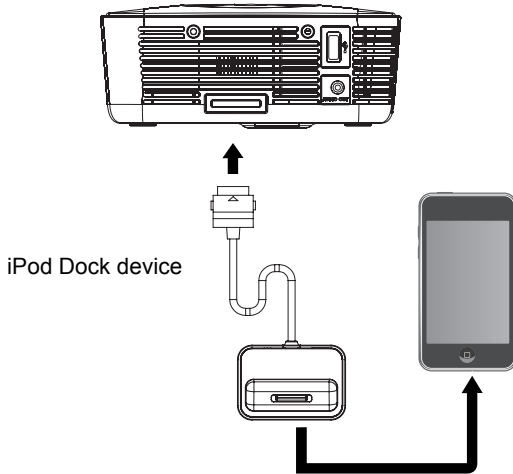

Maintenance

Care of the projector

Your projector needs little maintenance. The only thing you need to do on a regular basis is to keep the lens clean.

Never remove any parts of the projector except the lamp. Contact your dealer if other parts need replacing.

Cleaning the lens

Clean the lens whenever you notice dirt or dust on the surface.

- Use a canister of compressed air to remove dust.
- If there is dirt or smears, use lens-cleaning paper or moisten a soft cloth with lens cleaner and gently wipe the lens surface.

 **Never rub the lens with abrasive materials.**

Cleaning the projector case

Before you clean the case, turn the projector off using the proper shutdown procedure as described in "[Shutting down the projector](#)" on page 33 and unplug the power cord.

- To remove dirt or dust, wipe the case with a soft, lint-free cloth.
- To remove stubborn dirt or stains, moisten a soft cloth with water and a neutral pH detergent. Then wipe the case.

 **Never use wax, alcohol, benzene, thinner or other chemical detergents. These can damage the case.**

Storing the projector

If you need to store the projector for an extended time, please follow the instructions below:

- Make sure the temperature and humidity of the storage area are within the recommended range for the projector. Please refer to "[Specifications](#)" on page 55 or consult your dealer about the range.
- Retract the adjuster feet.
- Remove the battery from the remote control.
- Pack the projector in its original packing or equivalent.

Transporting the projector

It is recommended that you ship the projector with its original packing or equivalent.

Indicators

Status / Problems	LED indicators		
	Ring	Power	Key
Standby	Blue	Blue slow flash	Off
Power on	Blue	Blue	On
Cooling	Blue	Blue fast flash	Off
Fan1 error	Blue slow flash	Red fast flash	Off
Fan2 error	Blue slow flash	Red slow flash	Off
Temperature error	Blue slow flash	Red	Off

Troubleshooting

? The projector does not turn on.

Cause	Remedy
There is no power from the power cable.	Plug the AC adapter into the DC IN socket on the projector, plug the power cord into the AC inlet on the AC adapter, plug the power cord into the power outlet. If the power outlet has a switch, make sure that it is switched on.
Attempting to turn the projector on again during the cooling process.	Wait until the cooling down process has completed.

? No picture

Cause	Remedy
The video source is not turned on or connected correctly.	Turn the video source on and check that the signal cable is connected correctly.
The projector is not correctly connected to the input signal device.	Check the connection.
The input signal has not been correctly selected.	Select the correct input signal with the SOURCE key on the projector or remote control.

? Blurred image

Cause	Remedy
The projection lens is not correctly focused.	Adjust the focus of the lens using the focus ring.
The projector and the screen are not aligned properly.	Adjust the projection angle and direction as well as the height of the unit if necessary.

? Remote control does not work

Cause	Remedy
The battery is out of power.	Replace the battery with new one.
There is an obstacle between the remote control and the projector.	Remove the obstacle.
You are too far away from the projector.	Stand within 7 meters (23 feet) of the projector.

? The password is incorrect

Cause	Remedy
You do not remember the password.	Please see "Entering the password recall procedure" on page 24 for details.

Specifications

Projector specifications

 All specifications are subject to change without notice.

General	
Product name	Digital Projector
Model name	GP1
Optical	
Resolution	858 x 600 SVGA
Display system	1-CHIP DMD
Lens F/Number	F = 2, f = 17.67 mm
Lamp	LED
Electrical	
Power supply	AC19V, 4.74A, 50/60 Hz (Automatic)
Power consumption	60W (typical); <1W(Standby)
Mechanical	
Dimensions	136 mm (W) x 57 mm (H) x 120 mm (D)
Weight	Approx. 1.4lbs (640 g)
Input terminal	
Multi-input	
Computer input	D-Sub 15-pin (female) x 1
Component input	Analog - D-Sub <-> Component RCA jack x 3 (through RGB input)
Video input	RCA jack x 1
Audio input	RCA jack x 2
USB-A type	For USB Reader. Supports photo and movie files.
iPod input	iPod Dock with cable (optional accessory)
Output terminal	
Audio output	3.5 mm stereo mini jack (for USB Reader only)
Environmental Requirements	
Operating temperature	5°C–35°C at sea level
Operating relative humidity	35%–85% (without condensation)
Operating altitude	<ul style="list-style-type: none">• 0–1499 m at 5°C–35°C• 1500–3000 m at 5°C–30°C (with High Altitude Mode on)

Dimensions

136 mm (W) x 57 mm (H) x 120 mm (D)

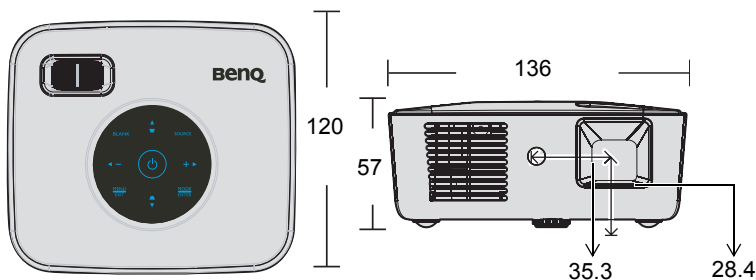

Timing chart

Supported timing for PC input

Resolution	Horizontal Frequency (kHz)	Vertical Frequency (Hz)	Mode
640 x 480	31.5	59.9	VGA
	37.9	72.8	
	37.5	75.0	
800 x 600	43.3	85.0	SVGA
	35.2	56.3	
	37.9	60.3	
	48.1	72.2	
1024 x 768	46.9	75.0	XGA
	53.7	85.1	
	48.4	60.0	
	56.5	70.1	
1152 x 864	60.0	75.0	SXGA
	64.0	60.0	
	68.7	85.0	
	71.6	84.9	
	62.8	74.9	
	49.7	59.8	

Supported timing for Component-YPbPr/Video input

Video mode	Horizontal Frequency (kHz)	Vertical Frequency (Hz)
480i	15.8	60
480p	31.5	60
576i	15.6	50
576p	31.3	50
720p	45	60
720p	37.5	50
1080i	33.8	60
1080i	28.1	50

Warranty and Copyright information

Limited warranty

BenQ warrants this product against any defects in material and workmanship, under normal usage and storage.

Proof of purchase date will be required with any warranty claim. In the event this product is found to be defective within the warranty period, BenQ's only obligation and your exclusive remedy shall be replacement of any defective parts (labor included). To obtain warranty service, immediately notify the dealer from which you purchased the product of any defects.

Important: The above warranty shall be void if the customer fails to operate the product in accordance with BenQ's written instructions, especially the ambient humidity must be in-between 10% and 90%, temperature in-between 0°C and 35°C, altitude lower than 4920 feet, and avoiding to operate the projector in a dusty environment. This warranty gives you specific legal rights, and you may have other rights which vary from country to country.

For other information, please visit www.BenQ.com.

Copyright

Copyright 2009 by BenQ Corporation. All rights reserved. No part of this publication may be reproduced, transmitted, transcribed, stored in a retrieval system or translated into any language or computer language, in any form or by any means, electronic, mechanical, magnetic, optical, chemical, manual or otherwise, without the prior written permission of BenQ Corporation.

Disclaimer

BenQ Corporation makes no representations or warranties, either expressed or implied, with respect to the contents hereof and specifically disclaims any warranties, merchantability or fitness for any particular purpose. Further, BenQ Corporation reserves the right to revise this publication and to make changes from time to time in the contents hereof without obligation to notify any person of such revision or changes.

*DLP, Digital Micromirror Device and DMD are trademarks of Texas Instruments. Others are copyrights of their respective companies or organizations.

Regulation statements

FCC statement

CLASS B: This equipment generates, uses and can radiate radio frequency energy and, if not installed and used in accordance with the instructions, may cause harmful interference to radio communications. However, there is no guarantee that interference will not occur in a particular installation. If this equipment does cause harmful interference to radio or television reception, which can be determined by turning the equipment off and on, the user is encouraged to try to correct the interference by one or more of the following measures:

- Reorient or relocate the receiving antenna.
- Increase the distance between the equipment and receiver.
- Connect the equipment into an outlet on a circuit different from that to which the receiver is connected.
- Consult the dealer or an experienced radio/TV technician for help.

EEC statement

This machine was tested against the 89/336/EEC (European Economic Community) for EMC (Electronic Magnetic Compatibility) and fulfills these requirements.

WEEE directive

Disposal of Waste Electrical and Electronic Equipment by users in private households in the European Union.

This symbol on the product or on the packaging indicates that this can not be disposed of as household waste. You must dispose of your waste equipment by handing it over to the applicable take-back scheme for the recycling of electrical and electronic equipment. For more information about recycling of this equipment, please contact your city office, the shop where you purchased the equipment or your household waste disposal service. The recycling of materials will help to conserve natural resources and ensure that it is recycled in a manner that protects human health and environment.



Accessibility Requirements for Rehabilitation Act of 1973, Section 508

BenQ's commitment to accessible products allows us to support government in making accessible technology choices. BenQ's LCD monitors and projectors are compliant with Section 508 guidelines by including the assistive features as below:

- BenQ's monitors have colored "Power" indicators. While the indicator shows green, it means that the monitor is using the full power. While the indicator shows yellow or amber, it means that the monitor is in suspend or sleep mode and is using less than 2 watts of electricity.
- BenQ's monitors have a variety of settings of pre-programmed flicker-free timing to make the screen shown on the monitor readily accessible. The default timing setting is automatically turned on every time the monitor is powered up, and thus reduces the hassle of user intervention.
- BenQ's monitors and projectors have options for brightness and contrast adjustments that text and images could be displayed differently to meet the demands of the visually impaired. Other similar adjustments are also available by using the On-Screen Display (OSD) controls on the products.
- BenQ's monitors and projectors include user-selectable color controls, such as color temperature selections (Monitor: 5800K, 6500K and 9300K, Projector: 5500K, 6500K, 7500K and 9300K), with a wide range of contrast levels.
- BenQ's multimedia monitors and projectors usually have one or two speakers for audio performance which allow users (including hearing impaired) to interact with the computer systems connected. Speaker controls are typically located on the front-panel.
- Firmware of BenQ's monitors and projectors contain unique product information that helps computer systems to identify BenQ products and activate their Plug-and-Play function when connected.
- All BenQ's monitors and projectors are compatible with the PC99 standard. For example, connectors are color-coded to help users easily connecting products to computer systems correctly.
- Some models of BenQ's monitors and projectors contain additional USB and DVI ports for connection to more devices such as a special headphone to assist the hearing impaired.
- All BenQ monitors and projectors come with user manuals on compact discs which could be easily read by commercial software such as Adobe Reader via a connected computer system. These documents are also available on the BenQ's web site (www.BenQ.com <<http://www.BenQ.com>>). Other types of documents may be available upon requests.
- BenQ's customer service provides answers and assistance to all our customers through phone calls, facsimiles, e-mails, or web sites.