

# PENTAX

EN

Digital Camera

# Optio P70

## Operating Manual

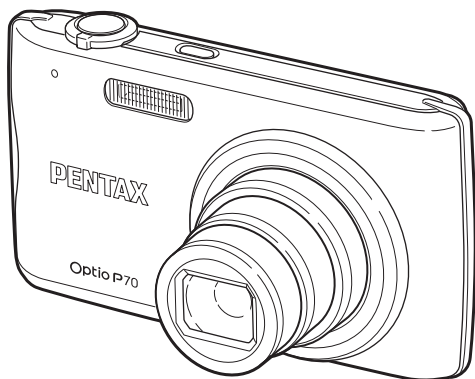

acdsee™



PictBridge



To ensure the best performance from your camera, please read the Operating Manual before using the camera.

Thank you for purchasing this PENTAX Digital Camera. Please read this manual before using the camera in order to get the most out of all the features and functions. Keep this manual safe, as it can be a valuable tool in helping you to understand all the camera capabilities.

### **Regarding copyrights**

Images taken using the PENTAX Digital Camera that are for anything other than personal enjoyment cannot be used without permission according to the rights as specified in the Copyright Act. Please take care, as there are cases where limitations are placed on taking pictures even for personal enjoyment during demonstrations, performances or of items on display. Images taken with the purpose of obtaining copyrights also cannot be used outside the scope of use of the copyright as laid out in the Copyright Act, and care should be taken here also.

### **Regarding trademarks**

- PENTAX, Optio and smc PENTAX are trademarks of HOYA CORPORATION.
- SDHC logo () is a trademark.
- ©2008 ACD Systems Ltd. All rights reserved. ACDSee and the ACDSee logo are trademarks of ACD Systems Ltd. in Canada, the U.S., Europe, Japan and other countries.
- Microsoft and Windows are registered trademarks of Microsoft Corporation in the United States and other countries. Windows Vista is either a registered trademark or trademark of Microsoft Corporation in the United States and/or other countries.
- Macintosh and Mac OS are trademarks of Apple Inc., registered in the U.S. and other countries.
- This product supports PRINT Image Matching III. PRINT Image Matching enabled digital still cameras, printers and software help photographers to produce images more faithful to their intentions. Some functions are not available on printers that are not PRINT Image Matching III compliant. Copyright 2001 Seiko Epson Corporation. All Rights Reserved. PRINT Image Matching is a trademark of Seiko Epson Corporation. The PRINT Image Matching logo is a trademark of Seiko Epson Corporation.
- All other brands or product names are trademarks or registered trademarks of their respective companies.

### **Regarding PictBridge**

PictBridge allows the user to connect the printer and digital camera directly, using the unified standard for the direct printout of images. You can print images directly from the camera through a few simple operations.

#### **Regarding Product Registration**

In order to better serve you, we request that you complete the product registration, which can be found on the CD-ROM supplied with the camera or the PENTAX website. Thank you for your cooperation.

Refer to "Connecting to a Computer" (p.199) for more information.

### To users of this camera

- Do not use or store this device in the vicinity of equipment that generates strong electromagnetic radiation or magnetic fields.  
Strong static charges or the magnetic fields produced by equipment such as radio transmitters could interfere with the monitor, damage data stored on the memory card, or affect the product's internal circuitry and cause camera misoperation.
- The liquid crystal panel used in the display is manufactured using extremely high precision technology. Although the level of functioning pixels is 99.99% or better, you should be aware that 0.01% or fewer of the pixels may not illuminate or may illuminate when they should not. However, this has no effect on the recorded image.
- There is a possibility that the illustrations and the display screen in this manual are different from the actual product.
- In this manual, both an SD Memory Card and an SDHC Memory Card are referred to as SD Memory Cards hereafter.
- In this manual, the generic term "computer(s)" refers to either a Windows PC or a Macintosh hereafter.

## USING YOUR CAMERA SAFELY

We have paid close attention to the safety of this product. When using this product, we request your special attention regarding items marked with the following symbols.



### **Warning**

This symbol indicates that violating this item could cause serious personal injuries.



### **Caution**

This symbol indicates that violating this item could cause minor or medium personal injuries, or material losses.

## About the Camera

### **Warning**

- Do not attempt to take the camera apart or remodel the camera. High voltages are present within the camera, and there is therefore a danger of electric shocks if the camera is taken apart.
- If the inside of the camera should become exposed as a result of, for example, the camera being dropped, please do not under any circumstances touch such exposed portions, as there is a danger of receiving an electric shock.
- To avoid the risk of it being swallowed by mistake, keep the SD Memory Card out of the reach of small children. Seek medical attention immediately if a card is accidentally swallowed.
- Wrapping the strap of the camera around your neck is also dangerous. Please take care that small children do not hang the strap around their necks.
- Use an AC adapter that is of the power and voltage specified for exclusive use with this product. The use of an AC adapter other than that specified exclusively for use with this product may cause fire or electric shocks.
- If the camera emits smoke or a strange smell, or in the event of any other irregularity, stop using the camera immediately, remove the battery and contact your nearest PENTAX Service Center. Continued use of the camera may result in fire or electric shock.

 **Caution**

- Do not charge any batteries other than rechargeable lithium-ion battery D-LI88. The battery could explode or catch fire.
- Do not place your finger on the flash when it is discharging as there is a risk of burns.
- Do not discharge the flash while it is touching your clothing as there is a risk of discoloring.
- If any leakage from the battery should come in contact with your eyes, it may cause a loss of sight. Flush your eyes with clean water and get medical attention immediately. Do not rub them.
- If any leakage from the battery should come in contact with skin or clothes, it may cause irritation to the skin. Wash the affected areas thoroughly with water.
- Precautions for D-LI88 Battery Usage:
  - BATTERY MAY EXPLODE OR FIRE IN MISTREATED.
  - DO NOT DISASSEMBLE OR DISPOSE OF IN FIRE.
  - DO NOT CHARGE EXCEPT SPECIFIED CHARGING CONDITION.
  - DO NOT HEAT ABOVE 140°F /60°C, OR SHORT CIRCUIT.
  - DO NOT CRUSH OR MODIFY.
- Remove the battery from the camera immediately if it becomes hot or begins to smoke. Be careful not to burn yourself during removal.
- Some portions of the camera heat up during use, so please take care, as there is a risk of low temperature burns if such portions are held for long periods of time.
- Should the LCD be damaged, be careful of glass fragments. Also, be careful not to allow the liquid crystal to get on your skin or in your eyes or in your mouth.
- Depending on your inherent factors or physical condition, the use of the camera may cause itching, rashes or blisters. In case of any abnormality, stop using the camera and get medical attention immediately.

## About the Battery Charger and the AC Adapter

### **Warning**

- Do not use the product at a voltage other than the specified voltage. Use with a power source or voltage other than that designated can cause a fire or electrical shock. The specified voltage is 100-240V AC.
- Do not disassemble or modify the product. This can cause a fire or electrical shock.
- If the generation of smoke or strange odor from the product or other abnormality occurs, immediately discontinue using and consult a PENTAX Service Center. Continuing to use the product can cause a fire or electrical shock.
- If water should happen to get inside the product, consult a PENTAX Service Center. Continuing to use the product can cause a fire or electrical shock.
- If a thunder storm should be present during use of the battery charger or AC adapter, unplug the power cord and discontinue use. Continuing to use the product can cause damage to the equipment, fire or electrical shock.
- Wipe off the plug of the power cord if it should become covered with dust. This can cause a fire.

### **Caution**

- Do not place heavy objects on the AC plug cord, allow heavy objects to drop onto it or allow the AC plug cord to become damaged due to excessive bending. If the AC plug cord becomes damaged, consult a PENTAX Service Center.
- Do not short or touch the output terminals of the product while it is still plugged in.
- Do not plug in the AC plug cord with wet hands. This can cause an electrical shock.
- Do not subject the product to strong impacts or allow it to drop onto a hard surface. This can cause a malfunction.
- Do not use the battery charger to charge batteries other than rechargeable lithium-ion battery D-LI88. This can cause overheating, explosion or malfunctions.





- To reduce the risk of hazards, use only CSA/UL Certified power supply cord set, cord is Type SPT-2 or heavier, minimum NO.18 AWG copper, one end with a molded-on male attachment plug cap (with a specified NEMA configuration), and the other is provided with a molded-on female connector body (with a specified IEC nonindustrial type configuration) or the equivalent.

## Care to be Taken During Handling

- When traveling, take the Worldwide Service Network listing that is included in the package. This will be useful if you experience problems abroad.
- When the camera has not been used for a long time, confirm that it is still working properly, particularly prior to taking important pictures (such as at a wedding or during traveling). Contents of the recording cannot be guaranteed if recording, playback or transferring your data to a computer, etc. is not possible due to a malfunction of your camera or recording media (SD Memory Card), etc.
- The lens on this camera is not interchangeable. The lens is not removable.
- Do not clean the product with organic solvents such as thinner, alcohol or benzene.
- Places of high temperature and humidity should be avoided. Particular care should be taken regarding vehicles, which can become very hot inside.
- This camera is not waterproof. Do not use this camera where it might come in contact with rain, water, or any other liquid.
- Storing the camera where pesticides and chemicals are handled should be avoided. Remove the camera from its case and store in a well-ventilated place to prevent the camera from becoming moldy during storage.
- Ensure that the camera is not subjected to substantial vibrations, shocks or pressure as this may cause damage or malfunction. Place the camera on a cushion for protection when the camera is subjected to the vibrations of a motorbike, car, ship, etc. If the camera is subjected to substantial vibrations, shocks or pressure, take your camera to your nearest PENTAX Service Center and have it checked.
- The temperature range in which the camera can be used is 0°C to 40°C (32°F to 104°F).
- The liquid crystal display will become black at a high temperature but will return to normal when normal temperatures are returned to.

- The response speed of the liquid crystal display becomes slow at low temperatures. This is due to the properties of the liquid crystal and is not a fault.
- Periodic checks are recommended every 1 to 2 years in order to maintain high performance.
- If the camera is subjected to rapid temperature changes, condensation may form on the inside and outside of the camera. Therefore put the camera in a bag or plastic bag, and take the camera out when the difference in temperature has subsided.
- Refer to “Precautions When Using an SD Memory Card” (p.37) regarding the SD Memory Card.
- Please note that formatting an SD Memory Card or the built-in memory will delete all data; however it may still be possible to recover that data using off-the-shelf data recovery software. Please manage your camera memory at your own risk.
- Please do not press forcefully on the display. This could cause breakage or malfunction.
- Be careful not to sit down with the camera in your back pocket as this may damage the exterior of the camera or the display.
- When using a tripod with the camera, be careful not to overtighten the screw in the tripod socket on the camera.
- The AC plug cord supplied with the camera is for exclusive use with the battery charger D-BC88. Do not use it with any other equipment.
- Storing the battery fully charged may decrease the battery performance. Avoid storing it especially in high temperatures.  
If the battery is left inserted and the camera is not used for a long time, the battery will over-discharge and shorten the battery’s service life.
- Charging the battery a day before use or on the day of use is recommended.

# Contents

USING YOUR CAMERA SAFELY .....	1
Care to be Taken During Handling .....	5
Contents .....	7
Composition of the Operating Manual .....	13
<b>Camera Features</b> .....	<b>14</b>
Checking the Contents of the Package .....	17
Names of Parts .....	18
Names of Operating Parts .....	19
Monitor Indications .....	20
<b>Getting Started</b> .....	<b>27</b>
<hr/>	
<b>Attaching the Strap</b> .....	<b>28</b>
<b>Powering the Camera</b> .....	<b>29</b>
Charging the Battery .....	29
Installing the Battery .....	30
Using the AC Adapter .....	33
<b>Installing the SD Memory Card</b> .....	<b>35</b>
Number of Images Recordable on an SD Memory Card .....	38
<b>Turning the Camera On and Off</b> .....	<b>39</b>
Starting-up in the Playback Mode .....	40
<b>Initial Settings</b> .....	<b>41</b>
Setting the Display Language .....	41
Setting the Date and Time .....	45
Vertical Snap Setting .....	46
<b>Common Operations</b> .....	<b>49</b>
<hr/>	
<b>Understanding the Button Functions</b> .....	<b>50</b>
 Mode .....	50
 Mode .....	52
Switching Between  Mode and  Mode .....	54
<b>Setting the Camera Functions</b> .....	<b>55</b>
Operating the Menus .....	55
Menu List .....	59

<b>Taking Still Pictures</b> .....	<b>64</b>
Taking Pictures.....	64
Setting the Shooting Mode.....	67
Using the Face Recognition Function.....	70
Taking Pictures Automatically (Auto Picture Mode).....	72
Taking Pictures in the Custom Settings (Program Mode).....	73
Taking Pictures in the Basic Mode (Green Mode).....	74
Using the Zoom.....	76
Simple Cellphone-style Picture Taking (Vertical Snap).....	78
Taking Pictures of Dark Scenes (Night Scene/Night Scene Portrait/ Digital SR/Fireworks/Candlelight Mode).....	81
Taking Pictures of People (Half-length Portrait/ Portrait/ Natural Skin Tone Mode).....	82
Taking Pictures of Children (Kids Mode).....	84
Taking Pictures of Your Pet (Pet Mode).....	85
Taking Pictures of Sports and Leisure Activities (Surf & Snow/ Sport Mode).....	86
Taking Pictures Indoors (Party Mode).....	87
Taking Pictures of Text (Text Mode).....	88
Framing Your Pictures (Frame Composite Mode).....	89
Using the Self-timer.....	91
Taking a Series of Pictures (Continuous Shooting/ Burst Shooting Mode).....	92
Using the Digital Wide Function (Digital Wide Mode).....	94
Taking Panoramic Pictures (Digital Panorama Mode).....	96
<b>Setting the Shooting Functions</b> .....	<b>99</b>
Selecting the Flash Mode.....	99
Selecting the Focus Mode.....	101
Selecting the Recorded Pixels.....	104
Setting the Exposure (EV Compensation).....	106
Adjusting the White Balance.....	107
Setting the AE Metering.....	109
Setting the Sensitivity.....	110
Setting Blink Detection.....	111
Setting Pixel Track SR.....	112
Setting the Instant Review.....	113
Setting the Image Sharpness (Sharpness).....	114
Setting the Color Saturation (Saturation).....	114
Setting the Image Contrast (Contrast).....	115
Setting the Date Imprint Function.....	116
Calling Up a Specific Function.....	117

<b>Recording Movies</b> .....	<b>119</b>
Recording a Movie .....	119
Selecting the Recorded Pixels and Frame Rate for Movies .....	121
Setting the Movie SR (Movie Shake Reduction) Function .....	122
<b>Saving the Settings (Memory)</b> .....	<b>123</b>
<b>Playing Back and Deleting Images</b> .....	<b>125</b>
<hr/>	
<b>Playing Back Images</b> .....	<b>126</b>
Playing Back Still Pictures .....	126
Playing Back a Movie .....	127
Multi-Image Display .....	128
Using the Playback Function .....	130
Slideshow .....	133
Registering/Playing Back Images in the FAVORITE Folder .....	135
Rotating the Image .....	138
Zoom Playback .....	139
Zoom In on the Subject's Face Automatically (Face Close-up Playback) .....	140
<b>Deleting Images</b> .....	<b>142</b>
Deleting a Single Image/Sound File .....	142
Deleting Selected Images and Sound Files .....	144
Deleting All Images and Sound Files .....	146
Recovering Deleted Images .....	147
Protecting Images and Sound Files from Deletion (Protect) .....	148
<b>Connecting the Camera to AV Equipment</b> .....	<b>151</b>
<b>Editing and Printing Images</b> .....	<b>153</b>
<hr/>	
<b>Editing Images</b> .....	<b>154</b>
Changing the Image Size (Resize) .....	154
Cropping Images .....	155
Using the Digital Filters .....	156
Red-eye Compensation .....	160
Adding a Frame (Frame Composite) .....	161
Editing Movies .....	164
Copying Images and Sound Files .....	166
<b>Setting the Printing Service (DPOF)</b> .....	<b>168</b>
Printing Single Images .....	168
Printing All Images .....	170

<b>Printing Using PictBridge .....</b>	<b>171</b>
Changing the USB Connection Mode.....	171
Connecting the Camera to the Printer .....	172
Printing Single Images.....	173
Printing All Images.....	175
Printing Using the DPOF Settings .....	176
Disconnecting the Cable from the Printer.....	176
<b>Recording and Playing Back Sound .....</b>	<b>177</b>
<b>Recording Sound (Voice Recording) .....</b>	<b>178</b>
Setting the Voice Recording Function .....	178
Recording Sound .....	179
Playing Back Sound .....	180
<b>Adding a Voice Memo to Images .....</b>	<b>181</b>
Recording a Voice Memo .....	181
Playing Back a Voice Memo .....	182
<b>Settings .....</b>	<b>183</b>
<b>Camera Settings.....</b>	<b>184</b>
Formatting an SD Memory Card.....	184
Changing the Sound Settings.....	185
Changing the Date and Time.....	186
Setting the World Time .....	189
Changing the Display Language .....	191
Changing the Naming Rule of the Folder .....	192
Changing the Video Output Format.....	193
Adjusting the Brightness of the Display .....	194
Using the Power Saving Function .....	195
Setting Auto Power Off .....	196
Changing the Start-up Screen .....	197
Resetting to Default Settings (Reset) .....	198
<b>Connecting to a Computer .....</b>	<b>199</b>
<b>Setting Up Your Computer.....</b>	<b>200</b>
Provided Software .....	200
System Requirements .....	201
Installing the Software .....	202
Setting the USB Connection Mode.....	206

<b>Connecting to a Windows PC .....</b>	<b>208</b>
Connecting the Camera and Windows PC .....	208
Transferring Images .....	209
Disconnecting the Camera from Your Windows PC .....	212
Starting "ACDSee for PENTAX 3.0" .....	213
Viewing Images .....	214
Details on How to Use "ACDSee for PENTAX 3.0" .....	215
<b>Connecting to a Macintosh .....</b>	<b>216</b>
Connecting the Camera and Macintosh .....	216
Transferring Images .....	217
Disconnecting the Camera from Your Macintosh .....	217
Starting "ACDSee 2 for Mac" .....	218
Viewing Images .....	219
Details on How to Use "ACDSee 2 for Mac" .....	219

## **Appendix**

**221**

---

<b>Functions Available for Each Shooting Mode.....</b>	<b>222</b>
<b>Messages.....</b>	<b>224</b>
<b>Troubleshooting.....</b>	<b>227</b>
<b>Default Settings.....</b>	<b>229</b>
<b>List of World Time Cities.....</b>	<b>234</b>
<b>Optional Accessories .....</b>	<b>235</b>
<b>Main Specifications .....</b>	<b>236</b>
<b>WARRANTY POLICY.....</b>	<b>240</b>
<b>Index.....</b>	<b>246</b>

In this manual, the method for operating the four-way controller is shown in illustrations, such as in the one below.

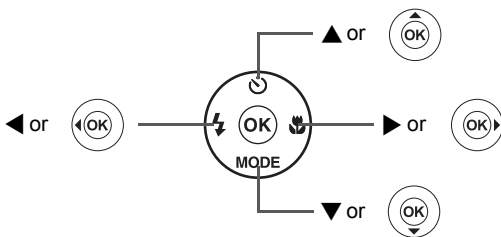

The meanings of the symbols used in this Operating Manual are explained below.

	indicates the reference page number for an explanation of the related operation.
	indicates information that is useful to know.
	indicates precautions to be taken when operating the camera.
mode	This is the mode for capturing still pictures and recording movies. In this manual, the mode for taking still pictures is referred to as the “Still Picture Capture Mode” and the mode for recording movies is referred to as the “ mode”.
mode	This is the mode for viewing still pictures and playing back movies and sound files.

# Composition of the Operating Manual

This Operating Manual contains the following chapters.

## 1 Getting Started

This chapter explains what you need to do after purchasing the camera before you start taking pictures. Be sure to read it and follow the instructions.

## 2 Common Operations

This chapter explains common operations such as the functions of the buttons and how to use the menus. For more details, refer to the respective chapters below.

## 3 Taking Pictures

This chapter explains the various ways of capturing images and how to set the relevant functions.

## 4 Playing Back and Deleting Images

This chapter explains how to view still pictures and movies on the camera or on TV and how to delete images from the camera.

## 5 Editing and Printing Images

This chapter explains the various ways of printing still pictures and how to edit images with the camera.

## 6 Recording and Playing Back Sound

This chapter explains how to record sound files or add sound (a voice memo) to an image, and how to play back sound files.

## 7 Settings

This chapter explains how to set the camera-related functions.

## 8 Connecting to a Computer

This chapter explains how to connect the camera to a computer, and includes installation instructions and a general overview of the provided software.

## 9 Appendix

This chapter deals with troubleshooting and lists the optional accessories.

1

2

3

4

5

6

7

8

9

# Camera Features

In addition to basic picture-taking, the Optio P70 has a variety of shooting modes to suit different situations. This section describes how to make the most of the key features of your camera. Together with the explanations of camera operations, it will enable you to enjoy your camera to the full.

## Easy Recording and Playback!

You can also hold it vertically to take pictures as if it was a cellphone. Even the buttons work like those on a cellphone, making picture taking a breeze. The Optio P70 also makes it easy for you to collect your favorite shots and show them to your friends.

- **Cellphone-like picture taking (p.78)**
- **Storage and simple playback of favorite shots (p.135)**

## Easy-to-Navigate Capture and Playback Functions!

The user-friendly design of the Optio P70 enables easy operation with only a few buttons. Simply by choosing the appropriate icon, you can select the shooting mode (p.67) and choose the optimal settings for the situation, or the playback mode (p.130, p.154) and enjoy the various playback and editing functions. A guide on the display lets you check the functions available in each mode and how to use them.



- **A shooting mode guide is displayed in the Capture Mode Palette and a playback mode guide in the Playback Mode Palette (p.67, p.130).**
- **Use the Green Mode to take pictures easily using standard settings (p.74).**

## Perfect for Portrait Shots!

The Optio P70 comes with a “Face Recognition” function that spots the faces in your shot and automatically adjusts the focus and exposure for the faces. It can recognize up to 32 people per shot (\*), so it will help you take perfect group shots too. It will automatically release the shutter when people are smiling, or if anyone blinked, it will tell you that so you can take the shot again until it is perfect. It also has a feature that lets you enlarge each person’s face in sequence during playback so you can quickly check their facial expressions.

\* Up to 15 face recognition frames are displayed on the monitor.

- **Face Recognition function (p.70)**
- **Modes for taking stunning pictures of people (p.82)**
- **Close-ups of people’s faces for easy checking during playback (p.140)**

## Add Various Frames to Your Pictures!

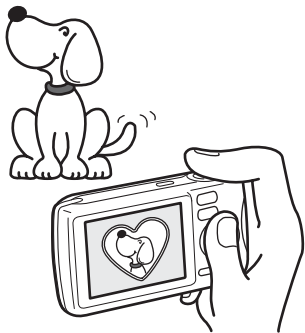

When you take a picture with the Optio P70, you can choose from a wide range of fun frames to create attractive framed shots (p.89). You can also add frames to pictures you have taken. Adjust the position of the subject in the picture or reduce or enlarge the picture size to match the frame shape and size. Now you no longer have to worry about the subject not fitting into the frame (p.161).

- **For decorating your pictures with a frame**

## Display Images and Sound Files in Calendar Format!

With the Optio P70, you can display recorded images and sound files by date in calendar format (p.129). This lets you quickly find the image or sound file you want to play back.

## Advanced Movie Recording Functions

The Optio P70 has a shake reduction function to reduce camera shake during movie recording (p.122). It also supports the 1280×720 HDTV image format so you can view your recordings as stunning wide-screen movies.

- **Use the camera to shoot fun-filled movies of your children or pets as a visual diary of their development (p.119).**

## A multitude of functions inside the camera for enjoying images without a Computer!

The Optio P70 has a variety of functions to let you enjoy playing back and editing images without having to connect the camera to your computer and transfer the images first. The camera is all you need to take and edit still pictures and movies (p.154). And no more worries about accidentally deleting images, because now, with the Optio P70, you can recover them again (p.147).

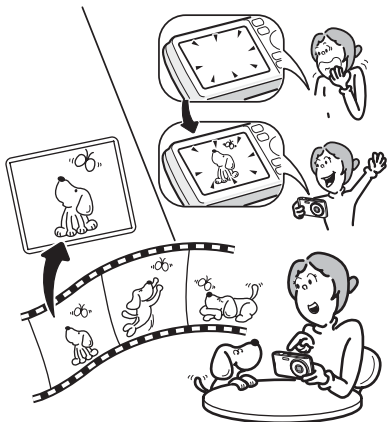

- **Resize (p.154), Cropping (p.155) and Red-eye Compensation (p.160) can be used, while the image is displayed in the playback mode.**
- **You can divide a movie into two or select a frame from a movie to save it as a still picture (p.164).**

## Checking the Contents of the Package



Camera  
Optio P70

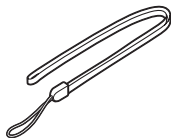

Strap  
O-ST51 (\*)

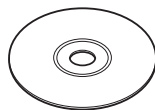

Software (CD-ROM)  
S-SW87

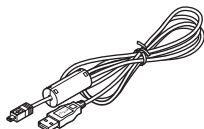

USB cable  
I-USB7 (\*)

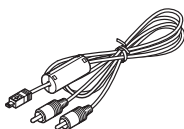

AV cable  
I-AVC7 (\*)



Rechargeable lithium-ion  
battery D-LI88 (\*)

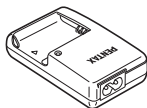

Battery charger  
D-BC88 (\*)



AC plug cord



Quick Guide



Operating Manual  
(this manual)

Items marked with an asterisk (\*) are also available as optional accessories. The battery charger and AC plug cord are only sold as a set (Battery Charger Kit K-BC88).

For other optional accessories, refer to "Optional Accessories" (p.235).

## Names of Parts

### Front

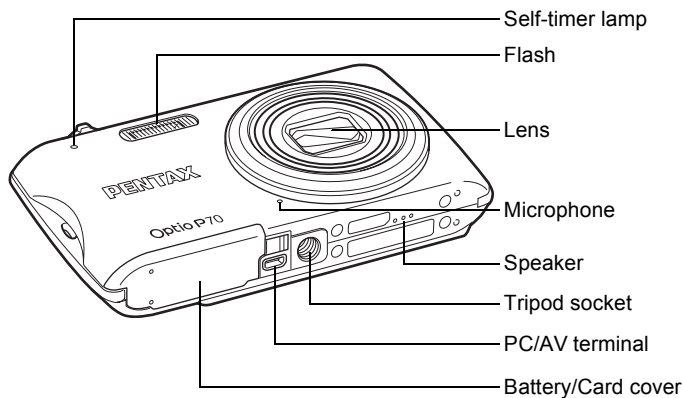

### Back

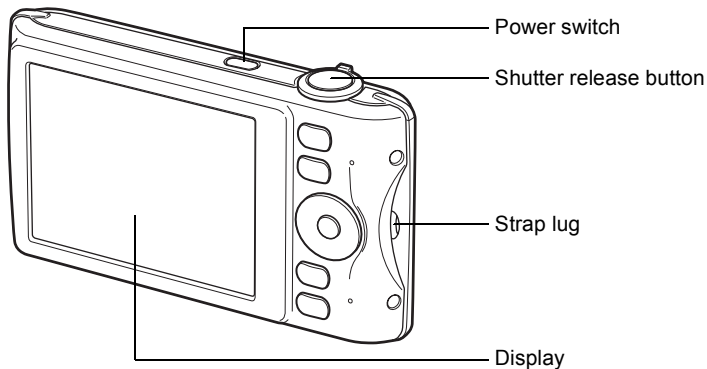

## Names of Operating Parts

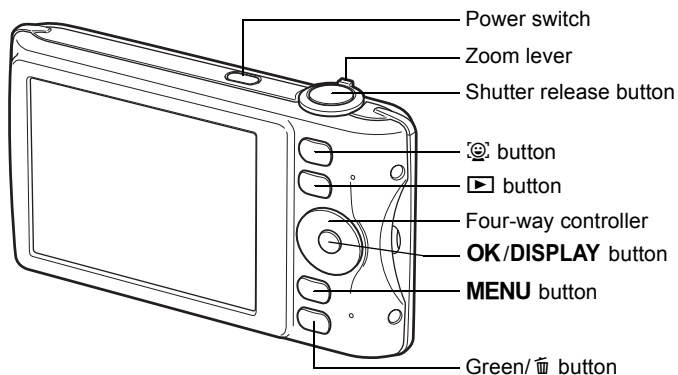



Refer to “Understanding the Button Functions” (p.50 - p.53) for an explanation of the function of each button.

# Monitor Indications

## Display in Mode

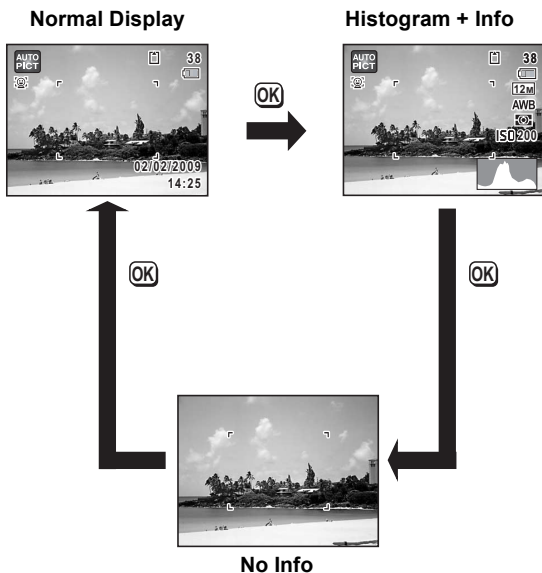
The display shows information such as the shooting conditions in the capture mode. The display changes in the following sequence each time you press the **OK/DISPLAY** button: “Normal Display”, “Histogram + Info” and “No Info”.



When the shooting mode is set to  (Green) mode, the monitor display is as shown on the right. You cannot change the information on the display by pressing the **OK/DISPLAY** button.



## Normal Display in Still Picture Capture Mode



- |   |                                     |
|---|-------------------------------------|
| 1 Shooting mode (p.67)                      | 10 Memory status (p.39)             |
| 2 Face Priority icon (p.70)                 | 11 Remaining image storage capacity |
| 3 Pixel Track SR icon (p.112)               | 12 Battery level indicator (p.32)   |
| 4 Shutter speed                             | 13 Focus frame (p.64)               |
| 5 Aperture                                  | 14 Date and time (p.45)             |
| 6 Flash Mode (p.99)                         | 15 EV Compensation (p.106)          |
| 7 Drive Mode (p.91, p.92)                   | 16 Date Imprint setting (p.116)     |
| 8 Focus Mode (p.101)                        | 17 World Time setting (p.189)       |
| 9 Digital Zoom/Intelligent Zoom icon (p.76) |                                     |

- \* For 3, appears if the shutter release button is pressed halfway when [Pixel Track SR] in the [Rec. Mode] menu is set to [Auto]. appears when [Pixel Track SR] is set to [Off].
- \* 4 and 5 appear only when the shutter release button is pressed halfway.
- \* For 8, when the focus mode is set to **AF** and the Auto-Macro function is activated, the appears on the display (p.101).
- \* Some indications may not appear depending on the shooting mode.

## Histogram + Info/No Info Display in Still Picture Capture Mode

A1 to A17 and B1 appear when “Histogram + Info” is selected. Only B1 appears when “No Info” is selected.

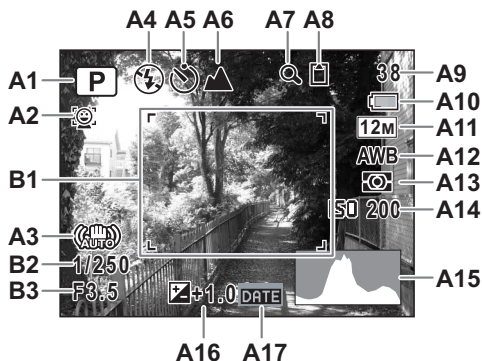

- |   |   |
|---|---|
| <b>A1</b> Shooting mode (p.67)                          | <b>A11</b> Recorded pixels (p.104)      |
| <b>A2</b> Face Priority icon (p.70)                     | <b>A12</b> White balance (p.107)        |
| <b>A3</b> Pixel Track SR icon (p.112)                   | <b>A13</b> AE Metering (p.109)          |
| <b>A4</b> Flash Mode (p.99)                             | <b>A14</b> Sensitivity (p.110)          |
| <b>A5</b> Drive Mode (p.91, p.92)                       | <b>A15</b> Histogram (p.25)             |
| <b>A6</b> Focus Mode (p.101)                            | <b>A16</b> EV Compensation (p.106)      |
| <b>A7</b> Digital Zoom/<br>Intelligent Zoom icon (p.76) | <b>A17</b> Date Imprint setting (p.116) |
| <b>A8</b> Memory status (p.39)                          | <b>B1</b> Focus frame (p.64)            |
| <b>A9</b> Remaining image storage capacity              | <b>B2</b> Shutter speed                 |
| <b>A10</b> Battery level indicator (p.32)               | <b>B3</b> Aperture                      |

- \* For A3, (AUTO) appears if the shutter release button is pressed halfway when [Pixel Track SR] in the [Rec. Mode] menu is set to [Auto]. (OFF) appears when [Pixel Track SR] is set to [Off].
- \* B2 and B3 appear only when the shutter release button is pressed halfway.
- \* When the shooting mode is **AUTO PICT** (Auto Picture) and if you press the shutter release button halfway, the automatically selected shooting mode appears in A1 even when “No Info” is selected (p.72).
- \* Some indications may not appear depending on the shooting mode.

## Display in Mode

The display shows the shooting information of the image in the playback mode. The display changes in the following sequence each time you press the **OK/DISPLAY** button: “Normal Display”, “Histogram + Info” and “No Info”.

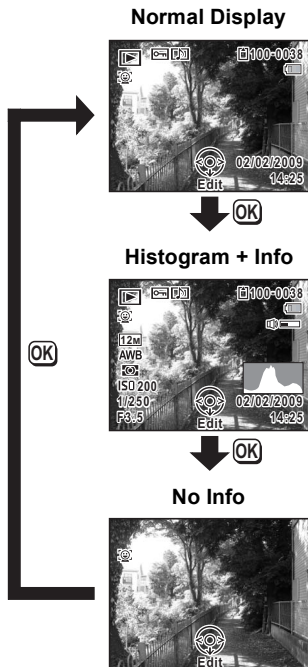

## Normal Display/Histogram + Info Display in Playback Mode

(All of the display items are displayed here for explanatory purposes.)

The display shows information such as the shooting conditions. A1 to A11 appear when “Normal Display” or “Histogram + Info” is selected. B1 to B7 appear only when “Histogram + Info” is selected.



- |  |  |
|--|--|
| <b>A1</b> Face Priority icon (p.70)  | <b>A9</b> Volume icon                    |
| <b>A2</b> Playback mode<br>▶ : Still Picture (p.126)<br>▶ : Movie (p.127)<br>▶ : Sound (p.180) | <b>A10</b> Captured date and time (p.45) |
| <b>A3</b> Protect icon (p.148)   | <b>A11</b> Four-way controller guide     |
| <b>A4</b> Voice memo icon (p.182)  | <b>B1</b> Recorded pixels (p.104)        |
| <b>A5</b> Memory status (p.39)   | <b>B2</b> White balance (p.107)          |
| <b>A6</b> Folder number (p.192)  | <b>B3</b> AE Metering (p.109)            |
| <b>A7</b> File number  | <b>B4</b> Sensitivity (p.110)            |
| <b>A8</b> Battery level indicator (p.32)   | <b>B5</b> Shutter speed                  |
|  | <b>B6</b> Aperture                       |
|  | <b>B7</b> Histogram (p.25)               |

- \* A1 appears only if the Face Recognition function worked when the image was shot.
- \* In “Normal Display”, A8 and A10 disappear if no operation is performed for two seconds.
- \* A9 appears only when the volume is being adjusted during playback of movies, sound files or voice memo. (p.127, p.180, p.182)
- \* A11 appears even when “No Info” is selected, but disappears if no operation is performed for two seconds. When no operation is performed for two seconds in “Normal Display” or “Histogram + Info”, only “Edit” disappears.

## Guide Indications

A guide for each available button operation appears as follows on the display during operation.

▲	Four-way controller (▲)
▼	Four-way controller (▼)
◀	Four-way controller (◀)
▶	Four-way controller (▶)
<b>MENU</b>	<b>MENU</b> button

	Zoom lever
<b>OK</b>	<b>OK/DISPLAY</b> button
<b>SHUTTER</b>	Shutter release button
	Green/ button
	button

## Using the Histogram

A histogram shows the brightness distribution of an image. The horizontal axis represents brightness (dark at the left and bright at the right) and the vertical axis represents the number of pixels.

The shape of the histogram before and after shooting tells you whether the brightness and contrast are correct or not, and lets you decide if you need to use EV compensation and take the picture again.

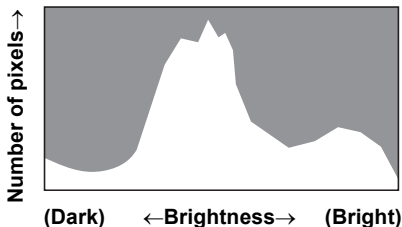

Setting the Exposure (EV Compensation) p.106

## Understanding Brightness

If the brightness is correct, the graph peaks in the middle. If the image is too dark, the peak is on the left side, and if it is too bright, the peak is on the right side.

Dark image

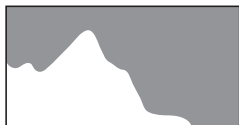

Correct image

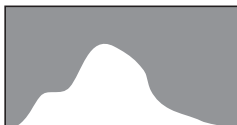

Bright image

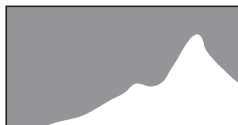

When the image is too dark, the part to the left is cut off (dark portions) and when the image is too bright, the part to the right is cut off (bright portions).

### **Understanding Contrast**

The graph peaks gradually for images in which contrast is balanced. The graph peaks on both sides but sinks in the middle for images with a large difference in contrast and low amounts of mid-level brightness.

# 1 Getting Started

---

<b>Attaching the Strap .....</b>	<b>28</b>
<b>Powering the Camera .....</b>	<b>29</b>
<b>Installing the SD Memory Card .....</b>	<b>35</b>
<b>Turning the Camera On and Off .....</b>	<b>39</b>
<b>Initial Settings .....</b>	<b>41</b>

# Attaching the Strap

Attach the strap (O-ST51) supplied with the camera.

1

Getting Started

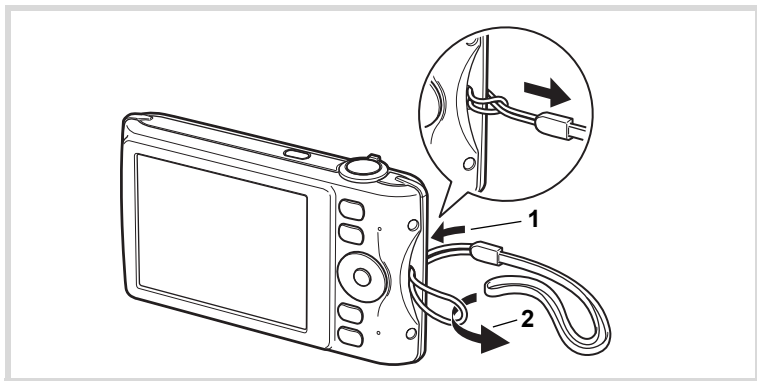

- 1** Pass the narrow end of the strap through the strap lug.
- 2** Pass the other end of the strap through the loop and pull tight.

## Charging the Battery

Use the supplied battery charger (D-BC88) to charge the supplied rechargeable lithium-ion battery (D-LI88) before using it in the camera for the first time or after a long period of non-use, or when the [Battery depleted] message appears.

Note: AC plug cord “Listed, Type SPT-2 or NISPT-2, 18/2 flexible cord, rated 125 V, 7A, minimum 6 ft (1.8 m)”

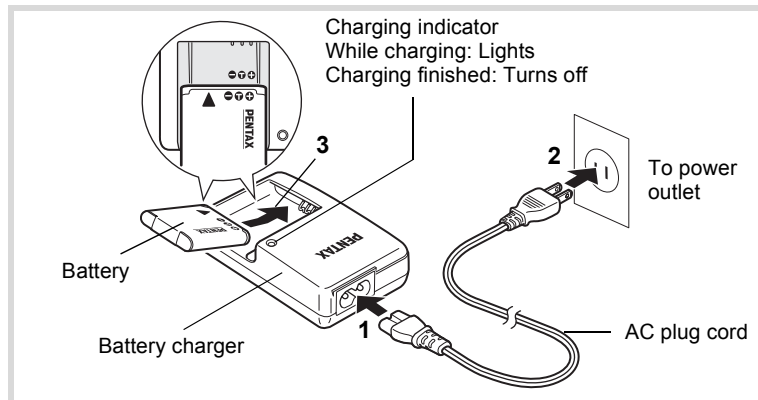

- 1** Connect the AC plug cord to the battery charger.
- 2** Plug the AC plug cord into the power outlet.
- 3** Place the battery in the battery charger so that the **PENTAX** logo is facing up.  
The charging indicator lights while the battery is charging and turns off when charging is finished.
- 4** Remove the battery from the battery charger when charging is finished.



- Do not use the supplied battery charger (D-BC88) to charge batteries other than the rechargeable lithium-ion battery D-LI88, as the battery charger may overheat or be damaged.
- The battery has reached the end of its service life when it starts to run down soon after being charged. Replace with a new battery.
- If the battery is inserted correctly but the charging indicator fails to light, the battery may be faulty. Replace with a new battery.



The time required to fully charge the battery is about 120 minutes (max.). (The charging time may vary depending on the ambient temperature and charging conditions.) The appropriate ambient temperature for charging the battery is 0°C to 40°C (32°F to 104°F).

## Installing the Battery

Use the rechargeable lithium-ion battery D-LI88 that is provided with the camera. Charge the battery before using it in the camera for the first time.

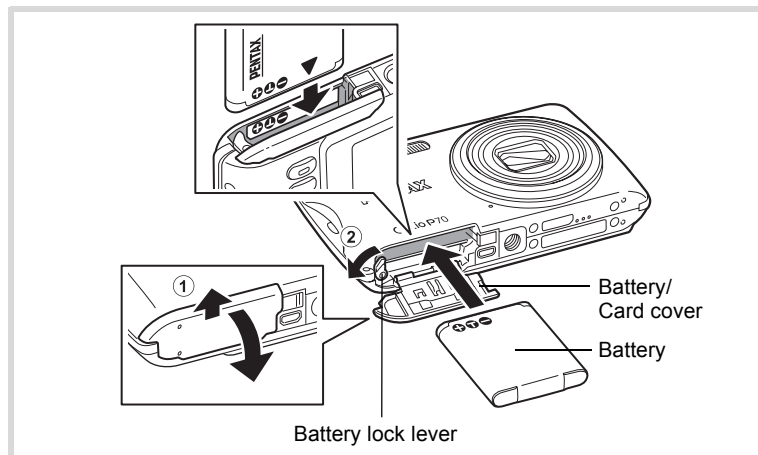

### 1 Open the battery/card cover.

Slide the battery/card cover toward the lens (1).

## 2 Press the battery lock lever in the direction of ② and insert the battery so that the PENTAX logo is facing toward the screen display.

Match the marks on the batteries to the marks inside the battery compartment and push the battery in until it is locked in place.



Make sure that the battery is inserted with the PENTAX logo pointing toward the screen display. If the battery is incorrectly oriented, malfunction may result.

## 3 Close the battery/card cover.

Close the battery/card cover and slide it toward the screen display.

### Removing the Battery

## 1 Open the battery/card cover.

## 2 Press the battery lock lever in the direction of ②.

The battery will be ejected. Take care not to drop the battery when removing it.



- This camera uses a rechargeable lithium-ion battery D-LI88. Use of any other type of battery may damage the camera and cause malfunction.
- Insert the battery correctly. If the battery is incorrectly oriented, malfunction may result.
- Do not remove the battery while the camera is turned on.
- When storing the battery for more than 6 months, charge the battery for 30 minutes using the battery charger and store the battery separately.  
Be sure to recharge the battery every 6 to 12 months. Storing the battery below room temperature is ideal. Avoid storing it in high temperatures.
- The date and time may be returned to the default setting if the camera is left without the battery for a long time.
- Be careful as the camera or the battery may become hot when the camera is used continuously for a long period of time.

- **Image Storage Capacity, Movie Recording Time, Sound Recording Time, and Playback Time**  
(at 23°C with the display on and the battery fully charged)

Image Storage Capacity <sup>*1</sup> (flash used for 50% of shots)	Movie Recording Time <sup>*2</sup>	Sound Recording Time <sup>*2</sup>	Playback Time <sup>*2</sup>
Approx. 200 pictures	Approx. 80 min.	Approx. 250 min.	Approx. 220 min.

- \*1 Recording capacity shows the approximate number of shots recorded during CIPA-compliant testing (with display on, flash used for 50% of the shots, and 23 degrees centigrade). Actual performance may vary according to operating conditions.
- \*2 According to the result of in-house testing.



- In general, battery performance may temporarily deteriorate as the temperature decreases.
- Be sure to take a spare battery with you when traveling abroad or to a cold region, or if you intend to take a lot of pictures.

### • Battery Level Indicator

You can check the battery level by the indicator on the display.

Screen Display	Battery Status
(green)	Adequate power remains.
(green)	Battery is running low.
(yellow)	Battery is running very low.
(red)	Battery is exhausted.
[Battery depleted]	The camera will turn off after this message appears.



- 6** Connect the DC terminal of the AC adapter to the DC terminal of the DC coupler.
- 7** Connect the AC plug cord to the AC adapter.
- 8** Plug the AC plug cord into the power outlet.

**Caution**

- Make sure that the camera is turned off before connecting or disconnecting the AC adapter.
- Make sure that the AC plug cord and the power cord connecting the AC adapter to the camera are inserted securely. The data may be lost if either becomes disconnected while data are being recorded on the SD Memory Card or the built-in memory.
- Use the AC adapter with due care to avoid fire or electric shock. Be sure to read “About the Battery Charger and the AC Adapter” (p.4) before using the AC adapter.
- Be sure to read the operation manual accompanying the AC adapter kit K-AC88 before using the adapter.
- When connecting the AC adapter, you cannot set the camera upright on the table because the cord from the DC coupler is extracted from the bottom side of the camera. Additionally, do not place the camera with the lens facing down because the lens extends when the camera turns on. Hold the camera in your hand or use a tripod when using the AC adapter and confirming the display to take pictures, view pictures or adjust the camera settings.

# Installing the SD Memory Card

This camera uses either an SD Memory Card or an SDHC Memory Card. (Both cards are referred to as SD Memory Cards hereafter.) Captured images and sound files are saved on the SD Memory Card if a card is inserted in the camera. They are saved in the built-in memory if a card is not inserted (p.39).



- **Be sure to use this camera to format (initialize) an SD Memory Card that is unused or has been used on other cameras or digital devices. Refer to “Formatting an SD Memory Card” (p.184) for instructions on formatting.**
- Make sure that the camera is turned off before inserting or removing the SD Memory Card.



- The still picture storage capacity varies depending on the capacity of the SD Memory Card and the selected number of recorded pixels and quality level (p.38).
- The self-timer lamp blinks while the SD Memory Card is being accessed (data are being recorded or read).

## Backing Up Data

The camera may not be able to access data in the built-in memory in the case of a malfunction. Use a computer or other device to back up important data in another location.

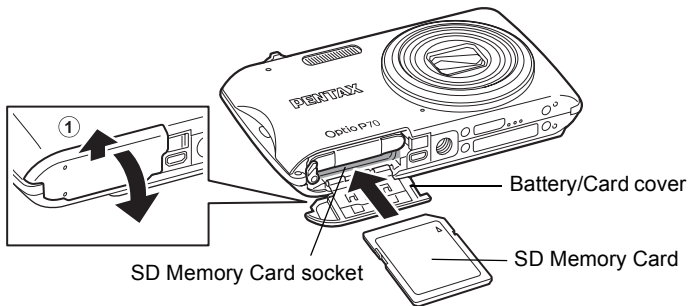



- 1 Open the battery/card cover.**  
Slide the battery/card cover toward the lens (①).
- 2 Insert the SD Memory Card into the SD Memory Card socket so that the label is facing toward the front of the camera (the side with the lens).**  
Push the card in all the way. Data may not be recorded correctly if the card is not inserted all the way.
- 3 Close the battery/card cover.**  
Close the battery/card cover and slide it toward the screen display.

#### To Remove the SD Memory Card

- 1 Open the battery/card cover.**
- 2 Push the card into the SD Memory Card socket to eject it.**  
Pull the card out.

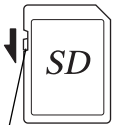
## Precautions When Using an SD Memory Card

- The SD Memory Card is equipped with a write-protect switch. Setting the switch to LOCK prevents new data from being recorded on the card, the stored data from being deleted, and the card from being formatted by the camera or computer.  
An illustration of an SD memory card with a write-protect switch on its left edge. The switch is shown in the 'LOCK' position, indicated by a downward-pointing arrow. The letters 'SD' are printed on the card's surface.

 appears on the display when the card is write-protected.
- Care should be taken when removing the SD Memory Card immediately after using the camera, as the card may be hot.
- Do not remove the SD Memory Card or turn the camera off while the data are being played back or saved to the card, or the camera is connected to a computer with the USB cable, as this may cause the data to be lost or the card to be damaged.
- Do not bend the SD Memory Card or subject it to violent impact. Keep it away from water and store away from high temperature.
- Do not remove the SD Memory Card during formatting as this may damage the card and render it unusable.
- The data on the SD Memory Card may be deleted in the following circumstances. We do not accept any liability for data that are deleted
  - (1) when the SD Memory Card is mishandled by the user.
  - (2) when the SD Memory Card is exposed to static electricity or electrical interference.
  - (3) when the SD Memory Card has not been used for a long time.
  - (4) when the SD Memory Card is ejected or the battery is removed while the data on the card are being recorded or accessed.
- If it is not used for a long time, the data on the card may become unreadable. Be sure to regularly make a backup of important data on a computer.
- Avoid using or storing the card where it may be exposed to static electricity or electrical interference.
- Avoid using or storing the card in direct sunlight or where it may be exposed to rapid changes in temperature or to condensation.
- When using an SD Memory Card with a slow recording speed, recording may stop while you are taking movies even when there is adequate space in the memory, or shooting and playback may take a long time.
- For information on compatible SD Memory Cards, visit the PENTAX website.
- Be sure to format an SD Memory Card that is unused or has been used on another camera. Refer to "Formatting an SD Memory Card" (p.184).
- Please note that formatting the SD Memory Card will not necessarily delete the data so that they cannot be recovered using off-the-shelf data recovery software. There are off-the-shelf secure data deletion software programs available that will completely delete the data. If you are going to discard, give away or sell your SD Memory Card, you should ensure that the data on the card are completely deleted or the card itself is destroyed if it contains any personal or sensitive information. In any case, the data on your SD Memory Card should be managed at your own risk.

## Number of Images Recordable on an SD Memory Card

1

Getting Started

The sizes of the recorded images differ depending on the number of recorded pixels of the images, so the number of images that will be saved on an SD Memory Card also differs.

Choose the appropriate number of recorded pixels for still pictures on the [📷 Rec. Mode] menu.

Selecting the Recorded Pixels 📷p.104

Choose the appropriate number of recorded pixels and frame rate in [Movie] on the [📷 Rec. Mode] menu.

Selecting the Recorded Pixels and Frame Rate for Movies 📷p.121

For an approximate guide to the number of images or the length of recorded movies that will be saved on an SD Memory Card, see “Main Specifications” (p.237).

# Turning the Camera On and Off

1

Getting Started

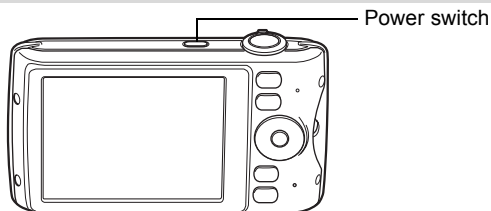

## 1 Press the power switch.

The camera turns on and the display turns on.

When you turn the camera on, the lens cover opens and the lens extends.

If the [Language/言語] screen or [Date Adjust] screen appears when you turn the camera on, follow the procedure on p.41 to set the display language and/or current date and time.

## 2 Press the power switch again.

The display turns off, the lens closes, and the camera turns off.

Taking Still Pictures p.64

## Checking the Memory Card

The memory card is checked when the camera turns on and the memory status is displayed.

	The SD Memory Card is inserted. Images and sound files will be saved on the SD Memory Card.
	The SD Memory Card is not inserted. Images and sound files will be saved in the built-in memory.
	The write-protect switch on the SD Memory Card is in the LOCK position (p.37). Images and sounds cannot be recorded.

Memory status



## Starting-up in the Playback Mode

Use this mode when you want to play back images or sound files straightaway without taking any more pictures.

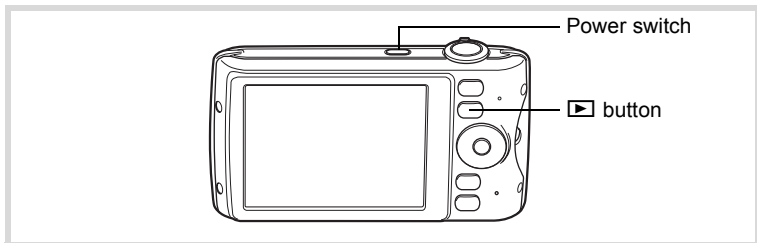

### 1 Press the power switch while holding down the ▶ button.

The display turns on with the lens retracted and the camera turns on in the playback mode.



To switch from the playback mode to the capture mode, press the ▶ button or press the shutter release button halfway.

Playing Back Still Pictures p.126

# Initial Settings

1

Getting Started

The [Language/言語] screen appears when the camera is turned on for the first time. Perform the operations in “Setting the Display Language” below to set the language, and in “Setting the Date and Time” (p.45) to set the current date and time.

The language, date, and time can be changed later. Refer to the pages below for instructions.

- To change the language, follow the steps in “Changing the Display Language” (p.191).
- To change the date and time, follow the steps in “Changing the Date and Time” (p.186).

## Setting the Display Language

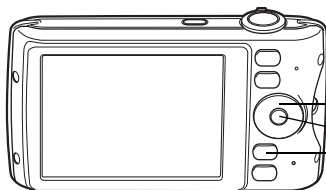

- Use the four-way controller (▲▼◀▶) to choose the display language.**

Language/言語		
English	日本語	Türkçe
Français	Dansk	Ελληνικά
Deutsch	Svenska	Русский
Español	Suomi	ไทย
Português	Polski	한국어
Italiano	Čeština	中文繁體
Nederlands	Magyar	中文简体
[MENU] Cancel		[OK] OK

## 2 Press the OK button.

The [Initial Setting] screen appears in the selected language. If the desired settings for [Hometown] and [DST] (Daylight Saving Time) appear, press the **OK** button again to display the [Date Adjust] screen. Go to “Setting the Date and Time” (p.45).

Go to Step 3 in “To Set Hometown and DST” (p.44) if the desired settings do not appear.

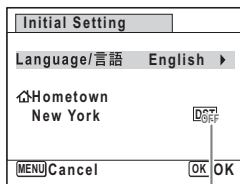

Daylight saving time

If you accidentally select another language and go to the next procedure, perform the following operation to set the language back.

● **When Another Language Has Been Inadvertently Selected**

- 1 Press the four-way controller (▶).**
- 2 Use the four-way controller (▲▼◀▶) to select the language and press the OK button.**

The [Initial Setting] screen appears in the selected language.

● **When the Screen After Step 2 Appears in Another Language**

- 1 Press the OK button.**
  - 2 Press the MENU button.**
  - 3 Press the four-way controller (▶).**
  - 4 Use the four-way controller (▼▲) to select [Language/言語].**
  - 5 Press the four-way controller (▶).**
- The [Language/言語] screen appears.
- 6 Use the four-way controller (▲▼◀▶) to select the language.**
  - 7 Press the OK button.**

The [↖ Setting] menu appears in the selected language.

The language is now switched to your desired language. To reset [Hometown], [Date] and [Time], refer to the pages below for instructions.

- To change [Hometown], follow the steps in "Setting the World Time" (☞p.189).
- To change the [Date] and [Time], follow the steps in "Changing the Date and Time" (☞p.186).

## To Set Hometown and DST

1

Getting Started

### 3 Press the four-way controller (▼).

The frame moves to [Hometown].

### 4 Press the four-way controller (▶).

The [Hometown] screen appears.

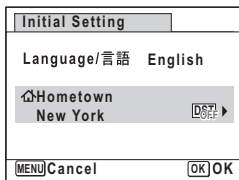

### 5 Use the four-way controller (◀▶) to choose the city.

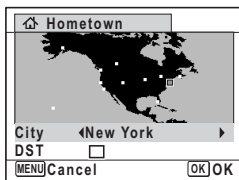

### 6 Press the four-way controller (▼).

The frame moves to [DST] (Daylight Saving Time).

### 7 Use the four-way controller (◀▶) to select (On) or (Off).

### 8 Press the OK button.

The [Initial Setting] screen appears.

### 9 Press the OK button.

The [Date Adjust] screen appears. Next, set the date and time.

The video output format (NTSC/PAL) is set to the format of the city selected in [Hometown] on the [Initial Setting] screen. Refer to "List of World Time Cities" (p.234) for the video output format of each city set as the initial setting, and "Changing the Video Output Format" (p.193) for changing the setting of the video output format.

## Setting the Date and Time

Set the current date and time and the display style.

### 1 Press the four-way controller (▶).

The frame moves to [mm/dd/yy].

### 2 Use the four-way controller (▲▼) to choose the date and time display style.

Choose from [mm/dd/yy], [dd/mm/yy] or [yy/mm/dd].

Date Adjust	
Date Style	mm/dd/yy 24h
Date	01/01/2009
Time	00:00
[MENU]Cancel [OK]OK	

### 3 Press the four-way controller (▶).

The frame moves to [24h].

### 4 Use the four-way controller (▲▼) to select [24h] (24-hour display) or [12h] (12-hour display).

Date Adjust	
Date Style	mm/dd/yy 24h
Date	01/01/2009
Time	00:00
[MENU]Cancel [OK]OK	

### 5 Press the four-way controller (▶).

The frame returns to [Date Style].

### 6 Press the four-way controller (▼).

The frame moves to [Date].

### 7 Press the four-way controller (▶).

The frame moves to the month.

Date Adjust	
Date Style	mm/dd/yy 24h
Date	▶01/01/2009
Time	00:00
[MENU]Cancel [OK]OK	

## 8 Use the four-way controller (▲▼) to change the month.

Change the day and year in the same manner. Next, change the time.

If you selected [12h] in Step 4, the setting switches between am and pm corresponding to the time.

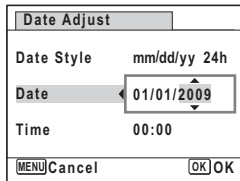

## 9 Press the OK button.

This confirms the date and time. Next, specify the Vertical Snap setting.



If you press the **OK** button in Step 9, the camera clock is reset to 00 seconds. To set the exact time, press the **OK** button when the time signal (on the TV, radio, etc.) reaches 00 seconds.

## Vertical Snap Setting

The “Vertical Snap” function enables you to take pictures with the camera held vertically, as if it was a cellphone. To use this function, first set “Vertical Snap” setting here.

See “Simple Cellphone-style Picture Taking (Vertical Snap)” (p.78) for details.

## 1 Use the four-way controller (▲▼) to select [On] or [Cancel].

- On Enables Vertical Snap shooting.
- Cancel Disables Vertical Snap shooting.

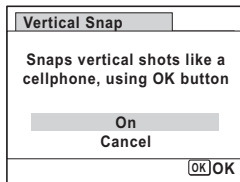

## 2 Press the OK button.

This confirms the Vertical Snap setting and completes Initial Setting. The camera returns to capture status.



When the [Initial Setting] or [Date Adjust] screen is displayed, you can cancel the setting operation and switch to the capture mode by pressing the **MENU** button. In this case, the [Initial Setting] screen will appear next time you turn the camera on.

[Language/言語], [Date], [Time], [Hometown], [DST], and [Vertical Snap] can be changed. Refer to the pages below for instructions.

- To change the language, follow the steps in “Changing the Display Language” (☞p.191).
- To change the date and time, follow the steps in “Changing the Date and Time” (☞p.186).
- To change the city or turn DST on and off, follow the steps in “Setting the World Time” (☞p.189).
- To change the Vertical Snap setting, follow the steps in “To Select Vertical Snap Setting” (☞p.80).

## Memo

# **2 Common Operations**

---

<b>Understanding the Button Functions</b>	<b>..... 50</b>
<b>Setting the Camera Functions</b>	<b>..... 55</b>

# Understanding the Button Functions

## Mode

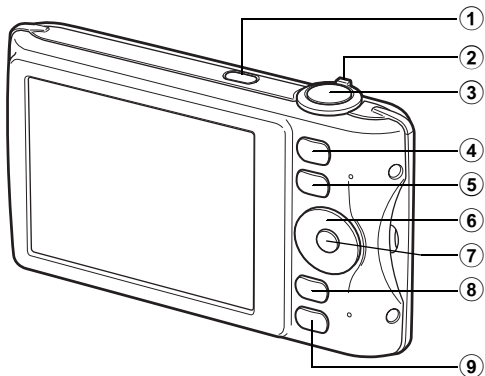

- ① **Power switch**  
Turns the camera on and off (p.39).
- ② **Zoom lever**  
Changes the captured area (p.76).
- ③ **Shutter release button**  
Focuses the camera on the subject when pressed halfway in Still Picture Capture Mode (except in **PF**, **▲** and **MF** modes).  
Takes the still picture when pressed down fully (p.65).  
Starts and stops movie recording in **Movie** mode (p.119).  
Starts and stops sound file recording in Voice Recording (p.179).
- ④ **☺ button**  
Switches the Face Recognition function (p.70). The Face Recognition function is switched as follows each time the ☺ button is pressed:  
Smile Capture → Face Priority Off → Face Priority On

- ⑤ **▶ button**  
Switches to the ▶ mode (p.54).
- ⑥ **Four-way controller**  
(▲) Changes the drive mode (p.91, p.92).  
(▼) Displays the Capture Mode Palette (p.67).  
(◀) Changes the flash mode (p.99).  
(▶) Changes the focus mode (p.101).  
(▲▼) Adjusts **MF** in **MF** mode (p.102).
- ⑦ **OK/DISPLAY button**  
Changes the information on the display (p.20).  
Turns the camera on and takes a picture in Vertical Snap mode. (p.78)
- ⑧ **MENU button**  
Displays the [📷 Rec. Mode] menu (p.55).  
Changes the flash mode in Vertical Snap mode (p.80).
- ⑨ **Green button**  
Switches to the ● (Green) mode (p.74).  
Calls up the assigned function (p.117).

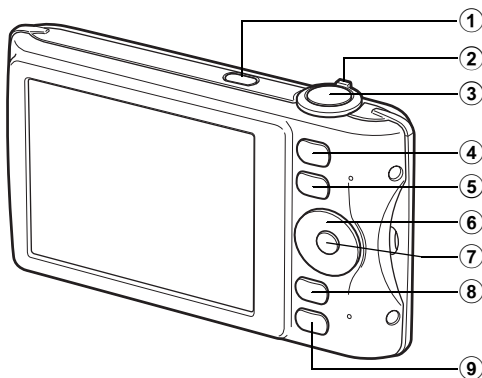

① **Power switch**

Turns the camera on and off (p.39).

② **Zoom lever**

Turn to the left (☒) during single-image display to change to four-image display. Changes to nine-image display when turned to the left again. Returns to the previous display when turned to the right (Q) (p.128).

Enlarges the image when turned to the right (Q) during single-image display. Returns to the previous display when turned to the left (☒) (p.139).

Turn to the left (☒) during nine-image display to change to folder or calendar display (p.129).

Turn to the right (Q) during folder/calendar display to change to nine-image display (p.129).



Adjusts the volume during playback of movies, sound files or voice memo (p.127, p.180, p.182).

③ **Shutter release button**



Switches to  mode (p.54).

④ **[Q] button**

Zooms in on the subject's faces in the face-recognized image in the order the faces were recognized when the picture was taken. (Face close-up playback) (p.140).

- ⑤ **▶ button**  
Switches to  mode (p.54).
- ⑥ **Four-way controller**  
(▲) Plays back and pauses a movie or sound file (p.127, p.180).  
(▼) Displays the Playback Mode Palette (p.132).  
Stops a movie or sound file during playback (p.127, p.180).  
(◀▶) Displays the previous or next image or sound file during single-image display (p.126).  
Fast-forwards, fast-reverses, frame forwards, frame reverses, reverses a movie and makes a movie play forwards during playback (p.127).  
Fast-forwards, fast-reverses, and moves to the next index in sound file playback (p.180).  
(▲▼◀▶) Moves the display area during zoom display (p.139).  
Selects an image in four-/nine-image display, a folder in folder display, and a date in calendar display (p.128, p.129).  
Moves the image when using the Frame Composite function (p.161).
- ⑦ **OK/DISPLAY button**  
Changes the information on the display (p.23).  
Returns zoom display or four-/nine-image display to single-image display (p.128, p.139).  
Changes to nine-image display of the selected folder during folder display (p.129).  
Changes to single-image display of the selected date during calendar display (p.130).
- ⑧ **MENU button**  
Displays the [ Setting] menu during single-image display (p.55).  
Returns to single-image display during Playback Mode Palette display (p.130).  
Returns zoom display or four-/nine-image display to single-image display (p.128).  
Changes to nine-image display of the selected folder during folder display (p.129).  
Changes to nine-image display of the selected date during calendar display (p.129).
- ⑨ **Green/  button**  
Switches from single-image display to the Delete screen (p.142).  
Switches from four-/nine-image display to the Select & Delete screen (p.144).  
Switches from folder display to the calendar display screen (p.129).  
Switches from calendar display to the folder display screen (p.129).

## Switching Between Mode and Mode

In this manual, the capture mode, such as for taking still pictures, is referred to as “ mode” (the capture mode). The playback mode, such as for displaying captured images on the display, is referred to as “ mode” (the playback mode). In  mode, you can perform simple editing operations on the images that are played back.

Follow the procedure below to switch between  mode and  mode.

### To Switch from Mode to Mode

#### 1 Press the button.

The camera switches to  mode.

### To Switch from Mode to Mode

#### 1 Press the button or the shutter release button halfway.

The camera switches to  mode.



### Displaying data stored in the built-in memory

When an SD Memory Card is inserted in the camera, images, movies, and sounds on the SD Memory Card are displayed. If you want to display images, movies and sounds in the built-in memory, turn the camera off and remove the SD Memory Card, or follow the procedure below to use the “Built-in memory display” function.



Make sure that the camera is turned off before inserting or removing the SD Memory Card.

#### ● Viewing images in the built-in memory while the SD Memory Card is inserted (built-in memory display)

- When you press and hold down the  button for more than one second in  mode, the lens is retracted. After the message [Display image/sound from built-in memory] appears, images, movies and sound files stored in the built-in memory are displayed.
- In the built-in memory display, you can play back still pictures (including enlarged display) (p.126, p.139), movies (p.127) and sounds (p.180), and switch between four-/nine-image display, folder display and calendar display (p.128).
- In the built-in memory display, you cannot delete data, delete a selection, display the Playback Mode Palette or display the menu. If you want to perform any of these operations on images, movies or sounds in the built-in memory, do so after removing the SD Memory Card.

# Setting the Camera Functions

To change the camera settings, press the **MENU** button to display the [📷 Rec. Mode] menu or [⚙️ Setting] menu. Menus for playing back and editing images and sound files are displayed from the Playback Mode Palette.

## Operating the Menus

Press the **MENU** button in 📷 mode to display the [📷 Rec. Mode] menu. Press the **MENU** button in ▶ mode to display the [⚙️ Setting] menu. Use the four-way controller (◀▶) to switch between [📷 Rec. Mode] menu and [⚙️ Setting] menu.

During recording

During playback

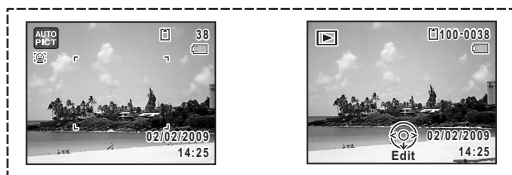

MENU

MENU

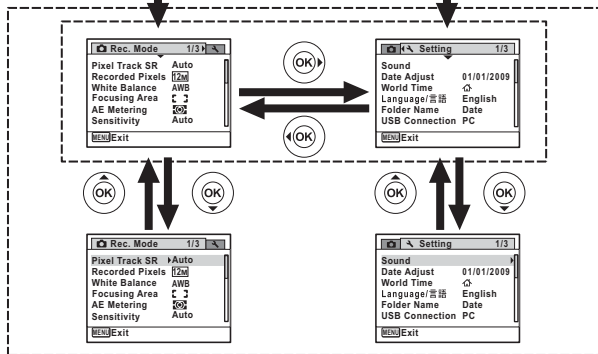

SHUTTER

MENU, OK or >

Press halfway



The setting is complete and the camera returns to mode.

The setting is complete and the camera returns to mode.



Available button operations appear on the display during menu operation.

Ex.) To set the [Focusing Area] on the [📷 Rec. Mode] menu

**1 Press the MENU button in 📷 mode.**

The [📷 Rec. Mode] menu appears.

**2 Press the four-way controller (▼).**

The frame moves to [Pixel Track SR].

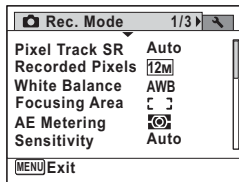

**3 Press the four-way controller (▼) three times.**

The frame moves to [Focusing Area].

**4 Press the four-way controller (▶).**

A pull-down menu appears with the items that can be selected.

The pull-down menu displays only those items that can be selected with the current camera settings.

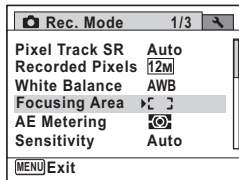

**5 Use the four-way controller (▲▼) to change the setting.**

The focusing area changes each time the four-way controller (▲▼) is pressed.

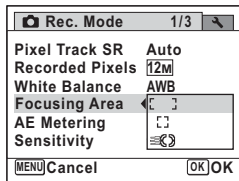

**6 Press the OK button or the four-way controller (◀).**

The setting is saved and then the camera is ready for setting the other functions. To exit the settings, press the **MENU** button.

To use another operation, refer to the alternate Step 6 options on the next page.

## To Save the Setting and Start Taking Pictures

### 6 Press the shutter release button halfway.

The setting is saved and the camera returns to capture status. When the shutter release button is pressed fully, the picture is taken.



When the [Setting] menu is displayed from [mode], you can switch to [mode] by pressing the [button] button.

## To Save the Setting and Start Playback of Images

### 6 Press the [button] button.

When the [Rec. Mode] menu is displayed from [mode], the setting is saved and the camera returns to playback status.

## To Cancel the Changes and Continue with Menu Operations

### 6 Press the MENU button.

The changes are canceled and the screen returns to Step 3.



The **MENU** button function differs depending on the screen. Refer to the guide indications.

- |        |   |
|--------|---|
| Exit   | Exits the menu and returns to the original screen.                                |
| ↶      | Returns to the previous screen with the current setting.                          |
| Cancel | Cancels the current selection, exits the menu and returns to the previous screen. |

## Menu List

This displays the items that can be set with the menus and provides descriptions of each item. See the list of default settings in the Appendix “Default Settings” (p.229) to decide whether you want the settings saved when the camera is turned off and whether you want the settings returned to the defaults when the camera is reset.

### [📷 Rec. Mode] Menu

This menu shows the functions related to taking still pictures and recording movies.

Item	Description	Page	
Pixel Track SR	For automatically correcting camera shake during shooting	p.112	
Recorded Pixels	For choosing the number of recorded pixels of still pictures	p.104	
White Balance	For adjusting the color balance according to the lighting conditions	p.107	
Focusing Area	For changing the area of the autofocus	p.103	
AE Metering	For setting the area of the screen that is metered to determine the exposure	p.109	
Sensitivity	For setting the sensitivity	p.110	
EV Compensation	For adjusting the overall brightness of the picture	p.106	
Movie	Recorded Pixels	For choosing the number of recorded pixels of movies	p.121
	Movie SR	For choosing whether or not to use the movie shake reduction function	p.122
Blink Detection	For choosing whether to use the Blink Detection function when the Face Recognition function worked	p.111	
Digital Zoom	For choosing whether or not to use the digital zoom function	p.77	
Instant Review	For choosing whether to display Instant Review	p.113	
Memory	For choosing whether to save the set values of the shooting function or return to the defaults when the camera is turned off	p.123	
Green Button	For assigning a function to the Green button in 📷 mode	p.117	
Sharpness	For choosing sharp or soft outlines	p.114	
Saturation	For setting the color saturation	p.114	
Contrast	For setting the image contrast level	p.115	
Vertical Snap	For choosing whether pictures can be taken using the <b>OK</b> button and four-way controller with the camera held vertically	p.78	
Date Imprint	For choosing whether to imprint the date and/or time when taking still pictures	p.116	

## ● [📷 Rec. Mode] Menu 1

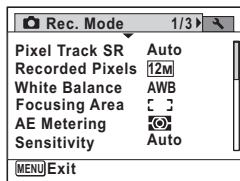

## ● [📷 Rec. Mode] Menu 2

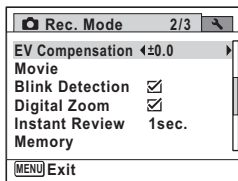

## ● [📷 Rec. Mode] Menu 3

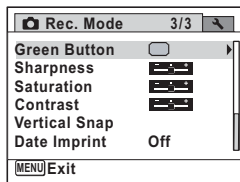

- Use the 📷 (Green) mode to enjoy easy picture-taking using standard settings, regardless of the settings in the [📷 Rec. Mode] menu (p.74).
- Assigning frequently used functions to the Green button enables you to go straight to the desired function (p.117).

## [🔧 Setting] Menu

Item	Description	Page
Sound	For adjusting the operation volume and playback volume, and setting the start-up sound, shutter sound, key operation sound and self-timer sound	p.185
Date Adjust	For adjusting the date and time	p.186
World Time	For setting the Hometown and Destination	p.189
Language/言語	For setting the language in which menus and messages appear	p.191
Folder Name	For choosing how names are assigned to folders for storing images and sound files	p.192
USB Connection	For setting the USB cable connection (to a computer or a printer)	p.171
Video Out	For setting the output format to the AV equipment	p.193
Brightness Level	For changing the brightness of the display	p.194

Item	Description	Page
Power Saving	For setting the time until the camera enters power-saving mode	p.195
Auto Power Off	For setting the time until the camera turns off automatically	p.196
Reset	For returning settings other than the date and time, language, world time and video out to their defaults	p.198
Delete all images	For deleting all the saved images and sound files at once	p.146
Format	For formatting the SD Memory Card	p.184

● [ Setting] Menu 1

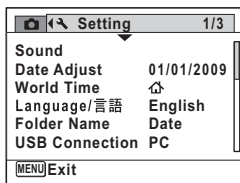

● [ Setting] Menu 2

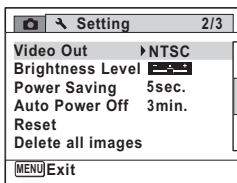

● [ Setting] Menu 3

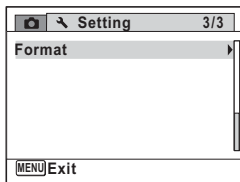

## Memo

# **3 Taking Pictures**

---

<b>Taking Still Pictures .....</b>	<b>64</b>
<b>Setting the Shooting Functions .....</b>	<b>99</b>
<b>Recording Movies .....</b>	<b>119</b>
<b>Saving the Settings (Memory) .....</b>	<b>123</b>

# Taking Still Pictures

## Taking Pictures

The Optio P70 features a wide range of shooting modes and functions to suit almost any subject or scene. This chapter describes how to take pictures with the most commonly used standard settings (the initial factory default settings).

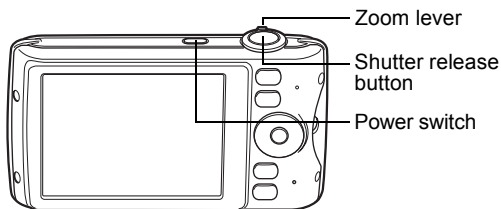

### 1 Press the power switch.

The camera turns on and is ready to take still pictures. In this manual, this is called “Still Picture Capture Mode”.

### 2 Confirm the subject and shooting information on the display.

The focus frame in the middle of the display indicates the zone of automatic focusing.

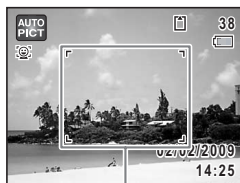

Focus frame

When the camera recognizes a person's face, the Face Recognition function is activated and the face recognition frame appears (p.70).



Face recognition frame

You can change the captured area by turning the zoom lever to the left or right (p.76).

- Right (▲) Enlarges the subject.
- Left (◆◆◆) Widens the area that is captured by the camera.

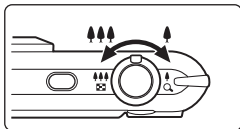

### 3 Press the shutter release button halfway.

The focus frame (or face recognition frame) on the display turns green when the camera focuses on the subject at the correct distance.



### 4 Press the shutter release button fully.

The picture is taken.  
The flash discharges automatically depending on the light conditions.  
The image appears on the display for one second (Instant Review: p.67) and is saved to the SD Memory Card or the built-in memory.



Press the Green button to switch to the ● (Green) mode and let the camera set all the shooting functions automatically (p.74).

## Using the Shutter Release Button

The shutter release button works in a two-step action as follows.

### Press halfway

This refers to pressing the shutter release button gently to the first position. This locks the focus setting and the exposure. The green focus frame lights on the display when the shutter release button is pressed halfway and the subject is in focus. If the subject is out of focus, the frame turns white.

3

### Press fully

This refers to pressing the shutter release button all the way down to the fully depressed position. This takes a picture.

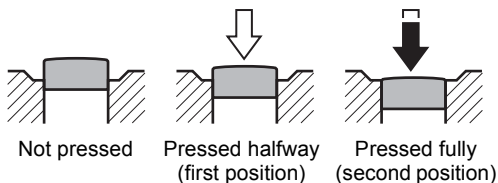

### Poor focusing conditions

The camera may not be able to focus under the following conditions. In these cases, lock the focus on an object the same distance away as the subject (by pressing and holding the shutter release button halfway), then aim the camera at your subject and press the shutter release button fully.

- Objects that lack contrast such as a blue sky or white wall
- Dark places or objects, or conditions that prevent light being reflected back
- Horizontal lines or intricate patterns
- Fast moving objects
- When there is an object in the foreground and an object in the background in the captured area
- Strongly reflected light or strong backlighting (bright background)



### 3 Press the OK button.









The shooting mode is selected and the camera returns to capture status.



There are 24 available shooting modes.

3

Shooting Mode	Description	Page
Auto Picture	Automatically selects the best capture mode.	p.72
Program	Used for basic shooting. Various functions can also be set with this mode.	p.73
Night Scene	For night time images. Use of a tripod or other support is suggested.	p.81
Night Scene Portrait	For images of people at night. Use of a tripod or other support is advised.	p.81
Half-length Portrait	For portraits with proper framing by automatic zoom. Fixed to  (2048×1536).	p.82
Movie	For recording movies.	p.119
Landscape	For capturing landscape views. Enhances colors of sky and foliage.	—
Flower	For images of flowers. The outline of the flower is softened.	—
Portrait	For capturing portraits. Reproduces a healthy and bright skin tone.	p.82
Surf & Snow	For bright images such as sand or snow. Accurately meters for bright scenes.	p.86
Sport	For a fast moving subject. Tracks the subject until the picture is taken.	p.86
Digital SR	Higher sensitivity reduces blur.	p.81
Kids	For capturing moving kids. Reproduces healthy and bright skin tone.	p.84
Pet	For capturing moving pets. Select the color according to the pet's coat.	p.85
Food	For images of food and prepared dishes. Enhances saturation and contrast.	—
Fireworks	For capturing fireworks. Use of a tripod or other support is suggested.	p.81

Shooting Mode		Description	Page
	Frame Composite	For capturing images with a frame. Recorded pixels is fixed to <b>3M</b> (2048×1536).	p.89
	Party	For capturing images at parties or in dim light. Increases ISO and clarity.	p.87
	Natural Skin Tone	For images of people. Enhances skin tones while smoothing blemishes.	p.82
	Candlelight	For capturing scenes in candlelight.	p.81
	Text	Captures text in an easy to read manner. Text contrast can be adjusted.	p.88
	Blog	Captures images for blogs or email. Recorded pixels fixed at <b>640</b> (640×480).	—
	Digital Wide	Stitches two pictures together to create a wider image.	p.94
	Digital Panorama	Stitches images taken with the camera to create a panoramic photograph.	p.96



- In shooting modes other than **P**, **M**, **A**, **S**, **(M)**, **C**, **WIDE** and **panorama**, saturation, contrast, sharpness, white balance, etc. are automatically set to the optimal settings for the selected mode.
- Some functions may not be available or may not function fully depending on the selected shooting mode. For details, refer to “Functions Available for Each Shooting Mode” (p.222).

## Using the Face Recognition Function

With the Optio P70, the Face Recognition function is available with all shooting modes. When the camera detects a person's face in the image, the Face Recognition function displays a yellow face recognition frame around the face on the display screen, sets the focus (Face Recognition AF) and compensates the exposure (Face Recognition AE).

If the subject in the face recognition frame moves, the frame also moves and changes size as it tracks the face.

The Face Recognition function can recognize up to 32 people's faces. If it recognizes multiple faces, the camera displays a yellow frame over the main face and white frames over the other face(s). It can display up to a total of 15 frames, including a main frame and white frame(s).



Face recognition frame

When the multiple faces are recognized

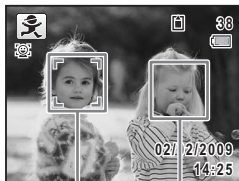

Main frame

White frame



- Face Recognition AF and AE may not work if the subject is wearing sunglasses, has part of the face covered or is not looking toward the camera.
- If the camera cannot recognize the subject's face, the camera focuses using the setting currently selected in [Focusing Area].
- When the Smile Capture function is on, the shutter may not be released automatically because the Smile Capture function may not work in some situations, such as when the recognized face is too small.

## To Switch the Face Recognition Function

By default, the Face Recognition function is set to Face Priority On. You can switch to the Smile Capture function, which automatically releases the shutter when your subject smiles. The Face Recognition function is switched as follows each time the  button is pressed: Smile Capture → Face Priority Off → Face Priority On

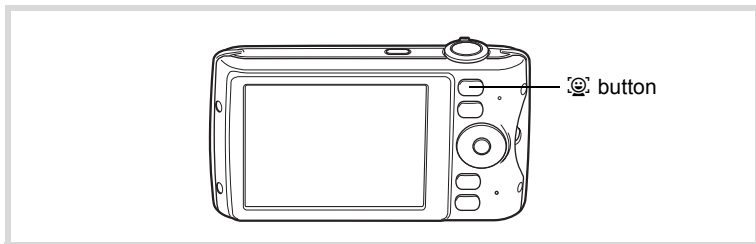

An icon indicating either Face Priority On or Smile Capture appears on the display. (The icon does not appear when the Face Recognition function is not activated.)

Face Priority On



Smile Capture



Face Priority Off

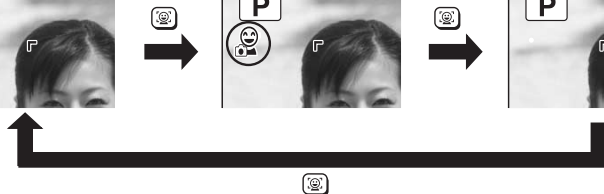

- The Face Recognition function cannot be set to off in **AUTO PICT** (Auto Picture), (Night Scene Portrait), (Half-length Portrait), (Portrait), (Kids) or (Natural Skin Tone) mode. You can select either Face Priority On or Smile Capture in these modes.
- Face Priority On is automatically selected in (Green), **AUTO PICT** (Auto Picture), (Night Scene Portrait), (Half-length Portrait), (Movie), (Portrait), (Kids) or (Natural Skin Tone) mode. When switching to another mode from one of these modes, the Face Recognition setting returns to the previous setting.
- If you use the Face Recognition function when the flash mode is set to (Auto), (Flash On + Red-eye) is automatically selected.

## Taking Pictures Automatically (Auto Picture Mode)

In **AUTO PICT** (Auto Picture) mode, the camera automatically selects the most appropriate mode depending on the situations and subjects.

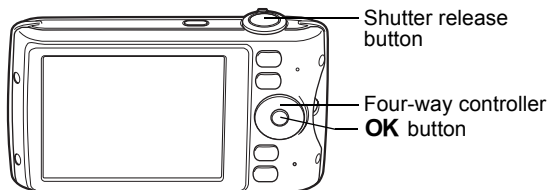

### 1 Press the four-way controller (▼) in **📷** mode.

The Capture Mode Palette appears.

### 2 Use the four-way controller (▲▼◀▶) to select **AUTO PICT**.

### 3 Press the OK button.

The **AUTO PICT** (Auto Picture) mode is selected and the camera returns to capture status.

When the camera recognizes a person's face, the Face Recognition function is activated and the face recognition frame appears (p.70).



### 4 Press the shutter release button halfway.

The selected shooting mode is displayed on the top left of the screen.

	Standard		Night Scene		Night Scene Portrait
	Landscape		Flower		Portrait
	Sport		Candlelight		

The focus frame on the display turns green when the camera focuses on the subject at the correct distance.

### 5 Press the shutter release button fully.

The picture is taken.



The following restrictions apply in **AUTO PICT** mode:

- You cannot turn the Face Recognition function off.
- The Focusing Area setting is fixed at [ ] (Multiple).
- The (Flower) mode cannot be selected when using Digital Zoom or Intelligent Zoom.
- If the (Night Scene) mode is selected when the flash mode is (Auto) or (Auto + Red-eye), the flash mode automatically changes to (Flash Off).
- If the (Night Scene Portrait) mode is selected when the flash mode is (Auto), the flash mode automatically changes to (Flash On + Red-eye) when the camera recognizes a face and determines that the flash is needed.
- The camera automatically focuses on the subject when the focus mode is set to **AF** (Standard) or (Macro).

## Taking Pictures in the Custom Settings (Program Mode)

In **P** (Program) mode, the camera automatically sets the shutter speed and aperture for taking still pictures. However, you can select other functions such as the flash mode and recorded pixels.

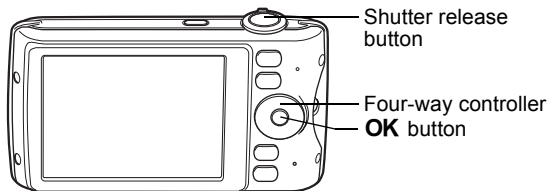

- 1 Press the four-way controller (▼) in mode.**  
The Capture Mode Palette appears.
- 2 Use the four-way controller (▲▼◀▶) to select **P**.**



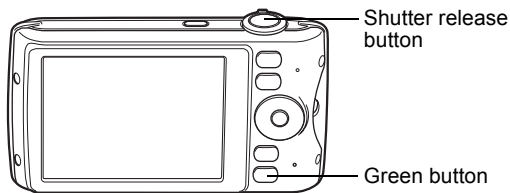

## 1 Press the Green button in mode.

The camera switches to  mode.

**Press the Green button again to return to the status before  mode was selected.**

When the camera recognizes a person's face, the Face Recognition function is activated and the face recognition frame appears (p.70).













## 2 Press the shutter release button halfway.

The focus frame on the display turns green when the camera focuses on the subject at the correct distance.

## 3 Press the shutter release button fully.

The picture is taken.





- Assign  mode to the [Green Button] on the [ Rec. Mode] for using  mode (p.117). (The default setting is  mode.)
- In  mode, you cannot change the information on the display by pressing the **OK/DISPLAY** button.
- Press the **MENU** button in  mode to display the [ Setting] menu. The [ Rec. Mode] menu cannot be displayed.
- When the camera is turned off in  mode, it turns on in  mode next time the power switch is pressed.

## Using the Zoom

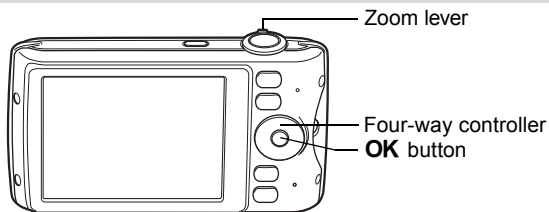
You can use the zoom to change the captured area.



### 1 Turn the zoom lever in mode.

- Right (  ) Enlarges the subject.
- Left (  ) Widens the area that is captured by the camera.

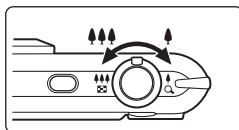

When you continue to turn to the right (  ), the camera automatically switches from optical zoom to Intelligent Zoom. Once the lever is released and turned again, the camera switches to Digital Zoom.

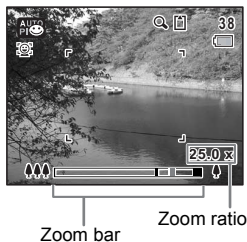

The zoom bar is displayed as follow.

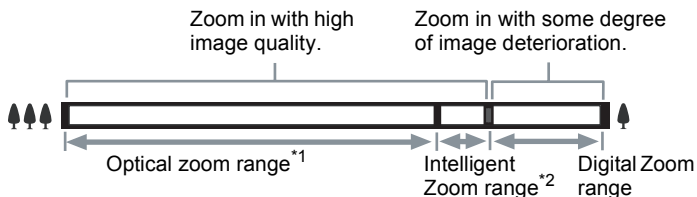

\*1 You can zoom in to a maximum of 4x optically.

\*2 The Intelligent Zoom range differs depending on the recorded pixels. See the following table.

## Recorded pixels and the maximum zoom ratio

Recorded pixels	Intelligent Zoom	Digital Zoom
/	Not Available (4× optical zoom only)	Equivalent to approx. 25.0×
	Approx. 5.2×	
	Approx. 6.2×	
	Approx. 7.8×	
	Approx. 8.3×	
	Approx. 15.6×	
	Approx. 25.0× (Same as Digital Zoom)	



- It is recommended to use a tripod to prevent camera shake when taking pictures at a high magnification rate.
- Pictures taken in the digital zoom range appear grainier than pictures taken in the optical zoom range.
- Intelligent Zoom is not available under the following conditions:
  - when the recorded pixels is set to / (4× optical zoom available)
  - in (Digital SR) mode
  - when the sensitivity is set to 3200 or 6400
- The image enlarged using Intelligent Zoom may appear rough on the display. This does not affect the quality of recorded image.
- In (Movie) mode, only Digital Zoom is available while recording.

### To Set the Digital Zoom

The digital zoom is set to  (On) in the default settings. To take pictures using only the optical zoom and Intelligent Zoom, set the digital zoom to  (Off).

## 1

**Press the MENU button in mode.**

The [ Rec. Mode] menu appears.

## 2

**Use the four-way controller ( ) to select [Digital Zoom].**

### 3 Use the four-way controller (◀▶) to select (On) or (Off).

- (On) Uses Digital Zoom
- (Off) Uses only optical zoom and Intelligent Zoom

The setting is saved.

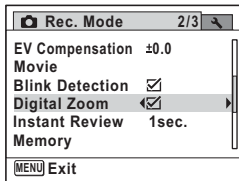

### 4 Press the **MENU** button.

The camera returns to capture status.

Saving the Digital Zoom Function setting p.123

## Simple Cellphone-style Picture Taking (Vertical Snap)

Vertical Snap lets you hold the camera vertically like a cellphone and take pictures using the **OK** button and four-way controller. If you selected [On] in “Vertical Snap Setting” (p.46) for Initial Setting, you can enjoy cellphone-style picture taking immediately by following the procedure below. If you selected [Cancel], you can set the camera for cellphone-style picture taking later using menu operations. For setting instructions, see “To Select Vertical Snap Setting” (p.80).

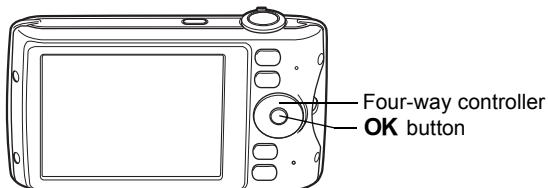

### 1 Make sure the power is turned off.

### 2 Press and hold the **OK** button.

The camera starts up in Vertical Snap mode.

### 3 Turn the camera clockwise and hold it in the vertical position.

In Vertical Snap mode, everything is displayed vertically on the display. When the camera recognizes a person's face, the Face Recognition function is activated and the face recognition frame appears (p.70).



### 4 Use the four-way controller (▲▼◀▶) to adjust the zoom and exposure.

The directions on the four-way controller are also realigned when you hold the camera vertically:

Four-way controller (▲/⚡)	Telephoto
Four-way controller (▼/👤)	Wide-angle
Four-way controller (◀/MODE)	Exposure compensation (-)
Four-way controller (▶/☺)	Exposure compensation (+)

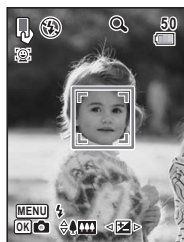

Using the Zoom p.76

Setting the Exposure (EV Compensation) p.106

### 5 Press the OK button.

The picture is taken.

### 6 To exit Vertical Snap mode, press the power switch.

The camera turns off. Press the power switch again to take a picture in normal shooting mode.



- The following settings are fixed in Vertical Snap mode:
  - Focus Mode **PF** (Pan Focus)
  - Drive Mode  (Standard)
  - Recorded Pixels **5M** (2592×1944)
- You can also use the shutter release button to take pictures in Vertical Snap mode. When you press the shutter release button halfway to set the focus, the camera takes the picture at the **AF** (Standard) setting. If the subject is out of focus, the camera takes the picture at the **PF** (Pan Focus) setting.
- The flash mode default setting for Vertical Snap is (Flash Off). By pressing the **MENU** button, you can switch between (Auto) and (Flash Off).
- Please take care not to cover the flash with your hand while taking pictures using the flash in Vertical Snap mode.
- The Green button and zoom lever do not function in Vertical Snap mode.
- The camera automatically turns off if it is not used for 5 minutes in Vertical Snap mode.

3

## To Select Vertical Snap Setting

### 1 Press the **MENU** button in mode.

The [ Rec. Mode] menu appears.

### 2 Use the four-way controller ( ) to select [Vertical Snap].

### 3 Press the four-way controller () to select [On].

The [Vertical Snap] screen appears.

### 4 Use the four-way controller ( ) to select [On] or [Cancel].

- On Enables Vertical Snap shooting.
- Cancel Disables Vertical Snap shooting.

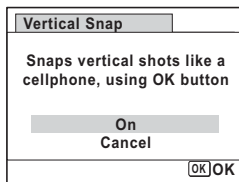

### 5 Press the **OK** button.





The setting is saved.

### 6 Press the **MENU** button.





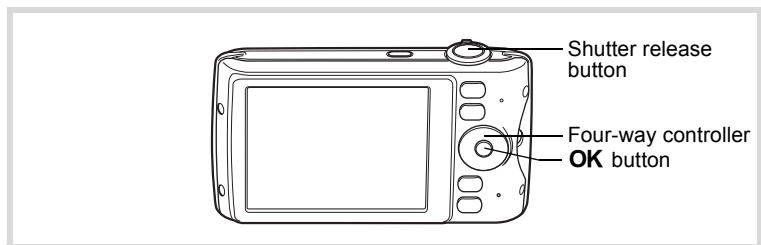

The camera returns to capture status.

## Taking Pictures of Dark Scenes (Night Scene/ Night Scene Portrait/Digital SR/Fireworks/ Candlelight Mode)

You can choose settings appropriate for taking pictures of dark scenes, such as nightscapes.

	Night Scene	For night time images. Use of a tripod or other support is suggested.
	Night Scene Portrait	For images of people at night. Use of a tripod or other support is advised.
	Digital SR	Higher sensitivity reduces blur.
	Fireworks	For capturing fireworks. Use of a tripod or other support is suggested.
	Candlelight	For capturing scenes in candlelight.



- 1 Press the four-way controller (▼) in  mode.**  
The Capture Mode Palette appears.
- 2 Use the four-way controller (▲▼◀▶) to select , , ,  or .**
- 3 Press the OK button.**  
The shooting mode is selected and the camera returns to capture status.  
When the camera recognizes a person's face, the Face Recognition function is activated and the face recognition frame appears (p.70).

#### 4 Press the shutter release button halfway.

The focus frame on the display turns green when the camera focuses on the subject at the correct distance.

#### 5 Press the shutter release button fully.

The picture is taken.





- The shutter speed tends to be slower when taking pictures of dark scenes.
- To prevent camera shake, set the Pixel Track SR function (p.112) or use a tripod and/or the self-timer function (p.91).
- In (👤) mode, the sensitivity is automatically set to Auto and the number of recorded pixels is fixed at [5M] (2592×1944).
- In (🌞) mode, the sensitivity is fixed at its minimum setting.
- If you use the Face Recognition function when the flash mode is set to  $\frac{1}{2}$  (Auto) in (👤) mode, (Flash On + Red-eye) is automatically selected.

### Taking Pictures of People (Half-length Portrait/Portrait/Natural Skin Tone Mode)

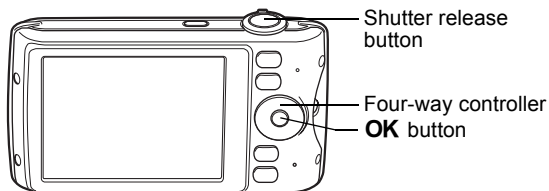

(👤) (Half-length Portrait), (👤) (Portrait) and (👤) (Natural Skin Tone) modes are suitable for taking pictures of people. Face Recognition function (p.70) operates for each shooting mode, making it easier to emphasize the subject's face when taking pictures.

	Half-length Portrait	For portraits with proper framing by automatic zoom. Fixed to [3M] (2048×1536).
	Portrait	For capturing portraits. Reproduces a healthy and bright skin tone.
	Natural Skin Tone	For images of people. Enhances skin tones while smoothing blemishes.



**1 Press the four-way controller (▼) in  mode.**

The Capture Mode Palette appears.

**2 Use the four-way controller (▲▼◀▶) to select ,  or  and press the OK button.**

The shooting mode is selected and the camera returns to capture status.

When the camera recognizes a person's face, the Face Recognition function is activated and the face recognition frame appears (p.70).

If the camera recognizes a person's face in  mode, an orange frame appears showing the area to be zoomed in.



**3 Press the shutter release button halfway.**

The focus frame on the display turns green when the camera focuses on the subject at the correct distance.

If the camera recognizes a person's face in  mode, the camera automatically zooms in to enlarge the area in the orange frame shown in Step 2.

**4 Press the shutter release button fully.**

The picture is taken.

## Taking Pictures of Children (Kids Mode)

☺ (Kids) mode is suitable for taking pictures of moving children. It also reproduces healthy and bright skin tone. Face Recognition function (p.70) operates automatically for this mode, making it easier to emphasize the subject's face when taking pictures.

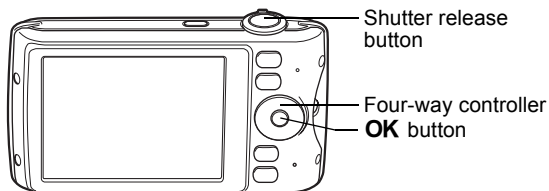

- 1 Press the four-way controller (▼) in  mode.**

The Capture Mode Palette appears.

- 2 Use the four-way controller (▲▼◀▶) to select ☺.**

- 3 Press the OK button.**

☺ (Kids) mode is selected and the camera returns to capture status.

When the camera recognizes a person's face, the Face Recognition function is activated and the face recognition frame appears (p.70).



- 4 Press the shutter release button halfway.**

The focus frame on the display turns green when the camera focuses on the subject at the correct distance.

- 5 Press the shutter release button fully.**

The picture is taken.

## Taking Pictures of Your Pet (Pet Mode)

Use this mode to keep your moving pet in focus while you take the picture and capture the color of your pet's coat. Choose the appropriate icon depending on what color your pet is (closer to black or white or in between).

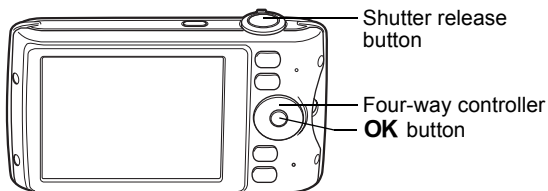

- 1 Press the four-way controller (▼) in mode.**  
The Capture Mode Palette appears.
- 2 Use the four-way controller (▲▼◀▶) to select .**

- 3 Press the OK button.**  
The Pet mode selection screen appears.

- 4 Use the four-way controller (▲▼) to select , , , , , or .**  
There are two types of icons: a cat and dog icon. Choosing either the cat or dog icon does not affect the resulting picture. Choose whichever you prefer.  
Choose an icon (white, gray, or black) whose tone best matches your pet's coat or fur.



- 5 Press the OK button.**  
Pet mode is selected and the camera returns to capture status.  
When the camera recognizes a person's face, the Face Recognition function is activated and the face recognition frame appears (p.70).



**6 Press the shutter release button halfway.**



The focus frame on the display turns green when the camera focuses on the subject at the correct distance.



The focus frame follows the subject while the shutter release button is pressed halfway.

**7 Press the shutter release button fully.**

The picture is taken.

## Taking Pictures of Sports and Leisure Activities (Surf & Snow/Sport Mode)

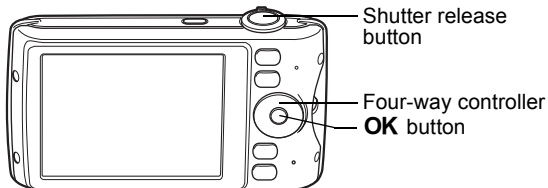
	Surf & Snow	For bright images such as sand or snow. Accurately meters for bright scenes.
	Sport	For a fast moving subject. Tracks the subject until the picture is taken.

**1 Press the four-way controller (▼) in  mode.**

The Capture Mode Palette appears.

**2 Use the four-way controller (▲▼◀▶) to select  or .****3 Press the OK button.**

The shooting mode is selected and the camera returns to capture status.

When the camera recognizes a person's face, the Face Recognition function is activated and the face recognition frame appears (p.70).



#### 4 Press the shutter release button halfway.

The focus frame on the display turns green when the camera focuses on the subject at the correct distance.

When Sport mode is selected, the focus frame follows the subject while the shutter release button is pressed halfway.

#### 5 Press the shutter release button fully.

The picture is taken.

## Taking Pictures Indoors (Party Mode)

☹ (Party) mode is perfect for taking pictures indoors, such as snapshots at parties.

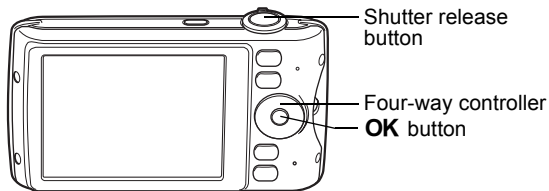

#### 1 Press the four-way controller (▼) in 📷 mode.

The Capture Mode Palette appears.

#### 2 Use the four-way controller (▲▼◀▶) to select ☹.

#### 3 Press the OK button.

Party mode is selected and the camera returns to capture status.

When the camera recognizes a person's face, the Face Recognition function is activated and the face recognition frame appears (p.70).

#### 4 Press the shutter release button halfway.





The focus frame on the display turns green when the camera focuses on the subject at the correct distance.

#### 5 Press the shutter release button fully.

The picture is taken.

## Taking Pictures of Text (Text Mode)

This mode allows you to take clear pictures of written text. This is convenient for capturing a digital copy of an important document or enhancing legibility of small print.

	Color	Maintains original colored text.
	Neg. Color	Reverses colored text.
	B & W	Turns colored text into black and white.
	Neg. B & W	Turns colored text into reversed black and white.

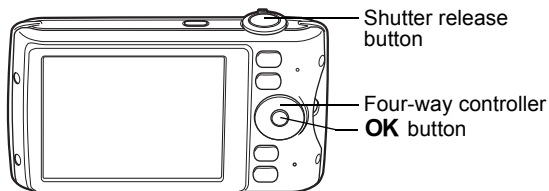

### 1 Press the four-way controller (▼) in mode.

The Capture Mode Palette appears.

### 2 Use the four-way controller (▲▼◀▶) to select .

### 3 Press the OK button.

The Text mode selection screen appears.

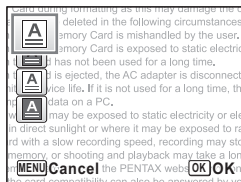

### 4 Use the four-way controller (▲▼) to select , , or .

## 5 Press the OK button.

The desired text mode is selected and the camera returns to capture status.

When the camera recognizes a person's face, the Face Recognition function is activated and the face recognition frame appears (p.70).

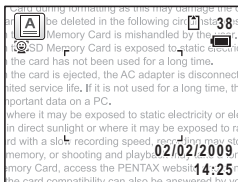

## 6 Press the shutter release button halfway.

The focus frame on the display turns green when the camera focuses on the subject at the correct distance.

## 7 Press the shutter release button fully.

The picture is taken.

## Framing Your Pictures (Frame Composite Mode)

In  (Frame Composite) mode, you can take pictures using the frames stored in the camera.

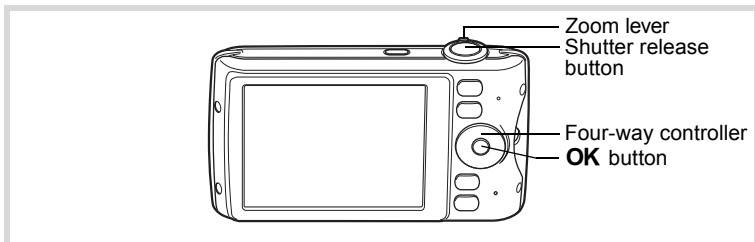

## 1 Press the four-way controller (▼) in mode.

The Capture Mode Palette appears.

## 2 Use the four-way controller (▲▼◀▶) to select and press the OK button.

The 9-frame display of the frame selection screen appears.

- 3** Use the four-way controller (▲▼◀▶) to choose the frame you want to use.

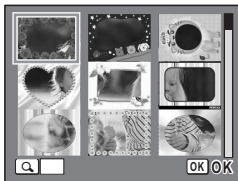

- 4** Turn the zoom lever to the right (Q).

The selected frame appears in single-image display.

You can choose another frame using either of the following operations.

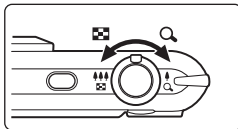

Four-way controller (◀▶)	Press to choose a different frame.
Zoom lever to the left (Q)	Turn to return to the 9-frame display of the frame selection screen, and then perform Step 3 to choose a different frame.

- 5** Press the OK button.

The frame appears on the display.

When the camera recognizes a person's face, the Face Recognition function is activated and the face recognition frame appears (p.70).





- 6** Press the shutter release button halfway.

The focus frame on the display turns green when the camera focuses on the subject at the correct distance.

- 7** Press the shutter release button fully.

The picture is taken.



- In  mode, recorded pixels is fixed at  (2048×1536).
- At shipment, the camera includes 3 default frames and 87 optional frames built-in. (The CD-ROM supplied with the camera contains a total of 90 frames, including the default frames.)

## Optional Frames



The optional frames are stored in the built-in memory in the Optio P70. These optional frames are deleted if the files on the built-in memory are deleted with a computer or the built-in memory is formatted. To reload the optional frames into the built-in memory, copy the files from the CD-ROM (S-SW87) supplied with the camera (p.163).

Adding a Frame to a captured image  p.161



## Using the Self-timer

In Self-timer mode, the picture is taken ten seconds or two seconds after the shutter release button is pressed.

Stabilize the camera with a tripod or other support when taking a picture with the self-timer.

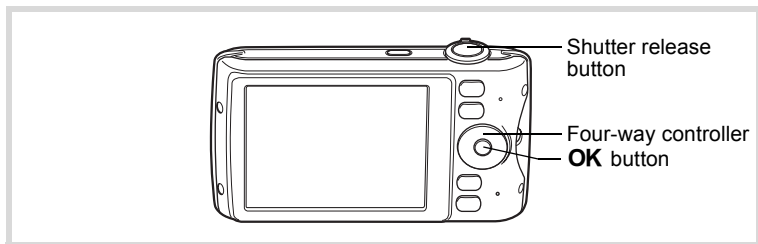
	<p>Use this mode when you want to be included in a group picture. The picture is taken approximately ten seconds after the shutter release button is pressed.</p>
	<p>Use this mode to avoid camera shake. The picture is taken approximately two seconds after the shutter release button is pressed.</p>



**1** Press the four-way controller () in  mode.

## 2 Use the four-way controller (◀▶▼) to select or and press the OK button.

The camera is ready to take the picture using the self-timer.

When the camera recognizes a person's face, the Face Recognition function is activated and the face recognition frame appears (p.70).



## 3 Press the shutter release button halfway.

The focus frame on the display turns green when the camera focuses on the subject at the correct distance.





## 4 Press the shutter release button fully.

The picture is taken ten seconds or two seconds later.





Focusing may be compromised if you move the camera while the self-timer lamp is blinking when taking still pictures.



- In  (Movie) mode, recording will start after ten seconds (or two seconds).
- Press the shutter release button halfway while the self-timer is engaged to stop the countdown and press fully to restart the countdown.
-  cannot be selected while  (Green) mode is in default setting. Select  in another shooting mode and then switch the shooting mode to .
- You cannot use the self-timer to take pictures in Vertical Snap mode.

## Taking a Series of Pictures (Continuous Shooting/Burst Shooting Mode)

In this mode, pictures are taken continuously as long as the shutter release button is pressed.

	Continuous Shooting	Each time a picture is taken, the image is saved in the memory before the next image is taken. The higher the image quality, the longer the interval between shots.
	Burst Shooting	Recorded pixels is fixed at  (2592×1944) and up to 6 pictures are taken consecutively at 3.2 frames per second (5.8 frames per second when sensitivity is 3200 or 6400).

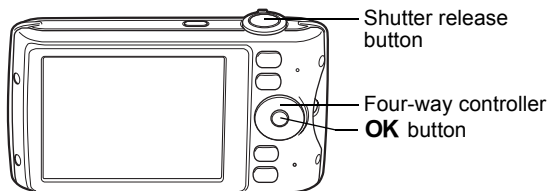

**1** Press the four-way controller (▲) in mode.

**2** Use the four-way controller (◀▶) to select or and press the OK button.

The camera is ready to take a series of pictures.



**3** Press the shutter release button halfway.

The focus frame on the display turns green when the camera focuses on the subject at the correct distance.

**4** Press the shutter release button fully.

Pictures are taken continuously as long as you keep the shutter release button pressed.



- The flash does not discharge in and modes.
- and cannot be selected in (Green), (Auto Picture), (Night Scene), (Movie), (Fireworks), (Frame Composite), (Digital Wide), (Digital Panorama) or Vertical Snap mode.



- In mode, you can continue shooting until the memory capacity of the SD Memory Card or the built-in memory is full.
- The interval of (Continuous Shooting) varies according to the Recorded Pixels and Quality Level settings.
- The focus, exposure and white balance are locked with the first shot.
- When the Face Recognition function is activated (p.70), it works only when taking the first shot.
- The Blink Detection function works only for the last shot.

## Using the Digital Wide Function (Digital Wide Mode)

In **WIDE** (Digital Wide) mode, you can stitch two captured images into a single frame up to approx. 28 mm coverage (35 mm film equivalent).

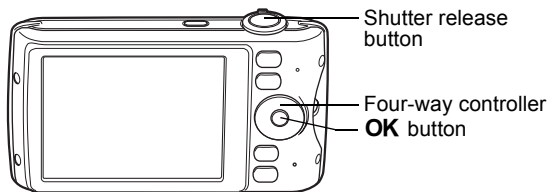
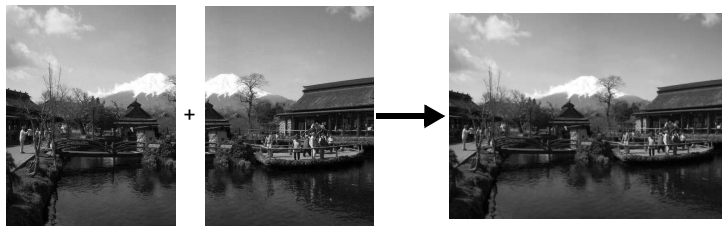

- 1 Press the four-way controller (▼) in  mode.**  
The Capture Mode Palette appears.
- 2 Use the four-way controller (▲▼◀▶) to select **WIDE**.**
- 3 Press the OK button.**

The camera enters the **WIDE** mode.  
Turn the camera 90° counterclockwise and align your first picture.  
When the camera recognizes a person's face, the Face Recognition function is activated and the face recognition frame appears (p.70).



#### 4 Press the shutter release button halfway.

The focus frame on the display turns green when the camera focuses on the subject at the correct distance.

#### 5 Press the shutter release button fully.

The first captured image is temporarily saved, and the shooting screen for the second image is displayed.



#### 6 Take the second image.

Overlap the image on the preview guide on the left of the screen to compose the second image. Repeat Steps 4 and 5 to take the second image.

The stitched first and second image appears on the display for one second (Instant Review), and then is saved.



- To minimize distortion when taking the second image, turn the camera so that it pivots around the right edge of the preview guide on the screen.
- Some distortion may result from moving objects, repeating patterns, or if nothing exists when overlapping the first and second image on the preview guide.
- When the Face Recognition function is activated (p.70), it works only when taking the first image.
- The number of recorded pixels for images captured with **WIDE** mode is fixed at **5M** (2592×1944).

## To Cancel after Taking the First Shot

- 1 When the shooting screen for the second image is displayed in Step 5 on p.95, press the **OK** button.

A confirmation dialog appears.

- 2 Use the four-way controller (**▲▼**) to select an option and press the **OK** button.

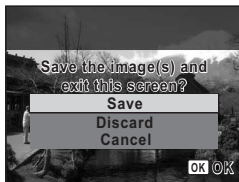

Save	Saves the first image and you can retake the first shot. The first image is saved in [3M] (2048×1536).
Discard	Discards the first image and you can retake the first shot.
Cancel	Returns to the shooting screen for the second image.

## Taking Panoramic Pictures (Digital Panorama Mode)

In **■** (Digital Panorama) mode, you can stitch two or three captured frames to create a panoramic photograph with the camera.

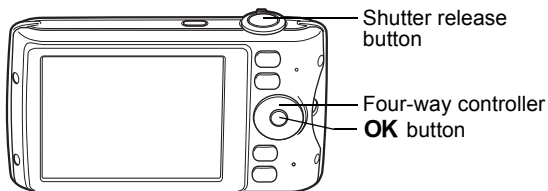

- 1 Press the four-way controller (**▼**) in **■** mode.

The Capture Mode Palette appears.

- 2 Use the four-way controller (**▲▼◀▶**) to select **■**.

### 3 Press the OK button.

The camera enters the **■■■** mode and the message [Set shift direction] is displayed.

### 4 Use the four-way controller (◀▶) to choose the direction in which the images will be joined.

The screen for taking the first frame is displayed.



When the camera recognizes a person's face, the Face Recognition function is activated and the face recognition frame appears (p.70).



### 5 Press the shutter release button halfway.

The focus frame on the display turns green when the camera focuses on the subject at the correct distance.

### 6 Press the shutter release button fully.

The screen for taking the second frame is displayed after you take the first frame.

#### If you select right (▶) in Step 4:

The right edge of the first frame appears in semi-transparent form on the left edge of the display.

#### If you select left (◀) in Step 4:

The left edge of the first frame appears in semi-transparent form on the right edge of the display.

### 7 Take the second frame.

Move the camera so that the semi-transparent image and the actual view overlap and press the shutter release button.

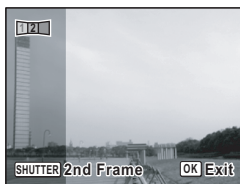

## 8 Take the third frame.

Repeat Steps 5 to 7 to take the third frame.

The panorama stitching starts and a stitched image appears.

The stitched image does not appear when the Instant Review (p.67, p.113) is off.



- Some distortion may result from moving objects, repeating patterns, or if nothing exists when overlapping the first and second frames or the second and third frames on the preview guide.
- When the Face Recognition function is activated (p.70), it works only when taking the first frame.

### To Cancel after Taking the First or Second Frame

#### 1 After shooting the first frame in Step 6 on p.97 or second frame in Step 7, press the OK button.

A confirmation dialog appears.

#### 2 Use the four-way controller (▲▼) to select an option and press the OK button.

Save	Saves the captured image(s) and you can retake the first frame. When this option is selected after shooting the second frame, the first and the second frames are stitched and saved as a panoramic photograph.
Discard	Discards the captured image(s) and you can retake the first frame.
Cancel	Returns to the previous shooting screen.

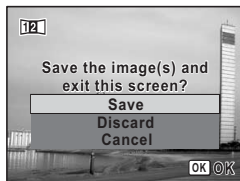

Unstitched images captured in **12** mode are fixed at **2M** (1600×1200).

# Setting the Shooting Functions

## Selecting the Flash Mode

	Auto	The flash discharges automatically depending on the light conditions.
	Flash Off	The flash does not discharge, regardless of the brightness. Use this mode to take pictures where flash photography is prohibited.
	Flash On	The flash discharges regardless of the brightness.
	Auto + Red-eye	This mode reduces the phenomenon of red eyes caused by the light from the flash being reflected in the subject's eyes. The flash discharges automatically.
	Flash On + Red-eye	This mode reduces the phenomenon of red eyes caused by the light from the flash being reflected in the subject's eyes. The flash discharges regardless of the light conditions.
	Soft Flash	This mode reduces the intensity of the flash so that the flash is not too bright even when fired at close range. The flash discharges regardless of the light conditions.



- The flash mode is fixed at in the following situations:
  - When (Movie) or (Fireworks) is selected as the capture mode
  - When (Continuous Shooting) or (Burst Shooting) is selected as the drive mode
  - When (Infinity) is selected as the focus mode.
- In (Green) mode, you can only select or .
- In (Night Scene) mode, you cannot select and .
- If you use Face Recognition function when is selected, the mode is automatically set to .
- A pre-flash discharges when using the red-eye reduction function.



Using the flash when capturing images at a close distance may cause irregularities in the image due to the light distribution.

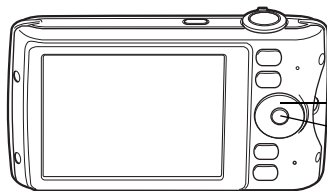

Four-way controller  
OK button

3

## 1 Press the four-way controller (◀) in mode.



The flash mode changes each time the button is pressed. You can also change the setting using the four-way controller (▲▼).



## 2 Press the OK button.



The setting is saved and the camera returns to capture status.

### About the red-eye phenomenon

Taking pictures using the flash may cause the subject's eyes to appear red in the resulting picture. This phenomenon occurs when the light from the flash is reflected in the subject's eyes. It can be reduced by illuminating the area around the subject or moving closer to the subject and zooming out to a wider angle. Setting the flash mode to  or  is also an effective way of reducing red eyes. If the subject's eyes appear red despite such precautions, they can be corrected by the red-eye compensation function (p.160).

Saving the Flash Mode setting  p.123

## Selecting the Focus Mode

<b>AF</b>	Standard	Use this mode when the distance to the subject is 40 cm (16 in.) or more. The camera is focused on the subject in the autofocus area when the shutter release button is pressed halfway.
	Macro	This mode is used when the distance to the subject is approx. 10 cm to 50 cm (4 in. to 20 in.). The camera is focused on the subject in the autofocus area when the shutter release button is pressed halfway.
<b>PF</b>	Pan Focus	This mode is used when you ask someone to take pictures for you, or when taking pictures of the scenery through the window of a car or train. The entire picture, from the front to the back, is focused.
	Infinity	This mode is used for taking distant objects. The flash is set to  (Flash Off).
<b>MF</b>	Manual Focus	This mode lets you adjust the focus manually.

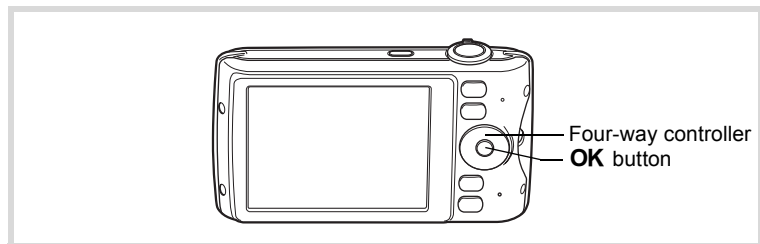

### 1 Press the four-way controller (▶) in mode.

The focus mode changes each time the button is pressed. You can also change the setting using the four-way controller (▲▼).

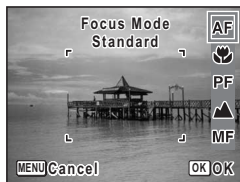

### 2 Press the OK button.

The setting is saved and the camera returns to capture status.



- In **AF** (Green) mode, you can only select **AF**, or **PF**.
- The focus mode is fixed at **MF** in (Fireworks) mode, and **PF** in Vertical Snap mode.
- When **AF** (Standard) is selected and the subject is closer than 40 cm, the camera automatically focuses from 10 cm (Auto-Macro function). In this case, appears on the display.
- When shooting with selected, if the subject is further than 50 cm away, the camera automatically focuses to  $\infty$  (Infinity). By pressing the shutter release button fully, you can also take a picture even when the focus is not set.

3

Saving the Focus Mode setting p.123

## To Set the Manual Focus

The procedure for setting the focus manually (**MF**) is described below.

**1** Press the four-way controller () in mode.

**2** Use the four-way controller () to select **MF**.

**3** Press the **OK** button.

The central portion of the image is magnified on the display to full screen.

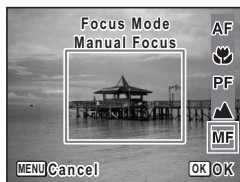

**4** Press the four-way controller (, ).

The **MF** indicator appears on the display to indicate the approximate distance to the subject. Use the four-way controller (, ) to adjust the focus using the indicator as a guide.

- ▲ for distant focus
- ▼ for closer focus

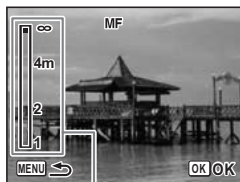

**MF** indicator

## 5 Press the OK button.

The focus is fixed and the camera returns to capture status. After the focus is fixed, you can press the four-way controller (▶) again to display the **MF** indicator and readjust the focus.



The shooting mode and drive mode cannot be changed while the **MF** indicator is displayed.



To switch from **MF** to another focus mode, press the four-way controller (▶) while the **MF** indicator is displayed.

## To Set the Focusing Area

You can change the autofocus area (Focusing Area).

[ ]	Multiple	Normal autofocus area
[ ]	Spot	The autofocus area becomes smaller.
[ ]	Automatic Tracking AF	Keeps moving subjects in focus.

## 1 Press the MENU button in mode.

The [ Rec. Mode] menu appears.

## 2 Use the four-way controller (▲▼) to select [Focusing Area].

## 3 Press the four-way controller (▶).

A pull-down menu appears.

## 4 Use the four-way controller (▲▼) to change the Focusing Area setting.

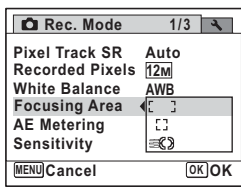

## 5 Press the OK button.

The setting is saved.

## 6 Press the MENU button.

The camera returns to capture status.



- In (Movie) and (Frame Composite) modes, Focusing Area cannot be set to .
- In (Green) and (Auto Picture) modes, Focusing Area is fixed at .
- If you change the [Focusing Area] setting frequently, you can save time by assigning it to the Green button (p.117).

3

## Selecting the Recorded Pixels

You can choose from eight recorded pixels settings for still pictures. The larger your recorded pixels, the clearer the details will appear when you print your picture. As the quality of the printed picture also depends on the image quality, exposure control, resolution of the printer and other factors, you do not need to select more than the required number of recorded pixels. **3M** is adequate for making postcard-size prints. The more pixels there are, the larger the picture and the bigger the file size. Refer to the following table for the appropriate settings according to use.

Recorded Pixels	Use
4000×3000 	Clearer For printing high quality photos or A4-size pictures or larger, or editing images on a computer.  For making postcard-size prints.  For a natural feeling of expansiveness with the same aspect ratio as HDTV.  For posting on a website or attaching to e-mail.
3072×2304	
2592×1944	
2048×1536	
1920×1080 (16 : 9)	
1024× 768	
640× 480	

The default setting is **12M**.



- Selecting **12M** provides better image quality than the **12M** setting, but with larger file sizes.
- If you select **2.1M**, the aspect ratio of the image is 16:9 and the monitor display for recording and playback is as shown on the right.



## 1 Press the **MENU** button in **📷** mode.

The [**📷** Rec. Mode] menu appears.

## 2 Use the four-way controller (**▲ ▼**) to select [**Recorded Pixels**].

## 3 Press the four-way controller (**▶**).

A pull-down menu appears.

## 4 Use the four-way controller (**▲ ▼**) to change the number of recorded pixels.

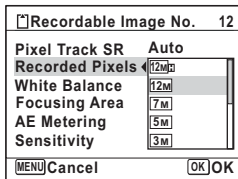

## 5 Press the **OK** button.

The setting is saved.

## 6 Press the **MENU** button.

The camera returns to capture status.



- The number of recorded pixels for images captured in (Green) mode is fixed at **12M**.
- The number of recorded pixels for images captured in (Half-length Portrait) or (Frame Composite) is fixed at **3M**.
- The number of recorded pixels for images captured in (Digital SR) or **WIDE** (Digital Wide) mode is fixed at **5M**. (The number of recorded pixels will be **3M** if you exit the Digital Wide mode without taking the second picture.)
- The number of recorded pixels for images captured in (Blog) is fixed at **640**.
- If you change the [Recorded Pixels] setting frequently, you can save time by assigning it to the Green button (p.117).

3

## Setting the Exposure (EV Compensation)

You can adjust the overall brightness of the picture.

Use this function to take pictures that are intentionally overexposed or underexposed.

### 1 Press the **MENU** button in mode.

The [ Rec. Mode] menu appears.

### 2 Use the four-way controller ( ) to select [EV Compensation].

### 3 Use the four-way controller ( ) to select the EV value.

To brighten, select a positive (+) value. To darken, select a negative (–) value.

You can choose the EV setting in the range of –2.0 EV to +2.0 EV in 1/3 EV steps.

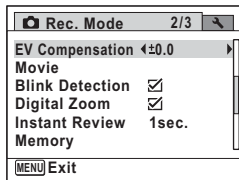

### 4 Press the **MENU** button.

The camera returns to capture status.



- When the histogram is displayed in Still Picture Capture Mode/ playback mode, you can check the exposure (p.25).
- The EV compensation function cannot be used in (Green) or (Auto Picture) mode.
- If you change the [EV Compensation] setting frequently, you can save time by assigning it to the Green button (p.117).

Saving the EV Compensation Value setting p.123

## Adjusting the White Balance

You can take pictures in natural colors by adjusting the white balance according to the light conditions at the time of shooting.

<b>AWB</b>	Auto	The camera adjusts the white balance automatically.
	Daylight	Use this mode when taking pictures outside in sunlight.
	Shade	Use this mode when taking pictures outside in the shade.
	Tungsten Light	Use this mode when taking pictures under electric or other tungsten light.
	Fluores. Light	Use this mode when taking pictures under fluorescent light.
	Manual	Use this mode when adjusting the white balance manually.



- Set another white balance if you are not satisfied with the color balance of pictures taken with the white balance set to **AWB**.
- Depending on the selected shooting mode, the white balance setting may not be changed. Refer to "Functions Available for Each Shooting Mode" (p.222) for details.

### 1 Press the MENU button in mode.

The [ Rec. Mode] menu appears.

### 2 Use the four-way controller ( ) to select [White Balance].

### 3 Press the four-way controller ()

The [White Balance] screen appears.

#### 4 Use the four-way controller (▲▼) to change the setting.

You can check the results of available white balance settings on the preview image each time you press the four-way controller (▲▼).

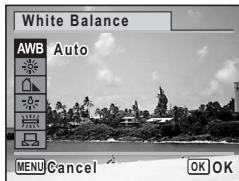

#### 5 Press the OK button.

The setting is saved.

#### 6 Press the MENU button.

The camera returns to capture status.

Refer to the following "Manual Setting" for instructions on adjusting the white balance manually.



If you change the [White Balance] setting frequently, you can save time by assigning it to the Green button (p.117).

Saving the White Balance setting p.123

### Manual Setting

Have a blank sheet of white paper or similar material ready.

#### 1 In the [White Balance] screen, use the four-way controller (▲▼) to select (Manual).

#### 2 Point the camera at the blank sheet of paper or other material so that it fills the frame displayed in the center of the screen.

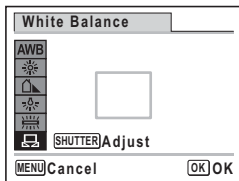

#### 3 Press the shutter release button fully.

The white balance is automatically adjusted.

**4 Press the OK button.**



The setting is saved and the screen returns to the [📷 Rec. Mode] menu.

**5 Press the MENU button.**

The camera returns to capture status.

**Setting the AE Metering**

You can set the area of the screen where the brightness is metered to determine the exposure.

	Multi-segment metering	The camera divides the image into 256 areas, meters the brightness and determines the exposure.
	Center-weighted metering	The camera takes a reading of the overall brightness of the picture with the center of the image having more influence on the exposure.
	Spot AE metering	The camera determines the exposure by metering the brightness only at the center of the image.

**1 Press the MENU button in 📷 mode.**

The [📷 Rec. Mode] menu appears.

**2 Use the four-way controller (▲▼) to select [AE Metering].****3 Press the four-way controller (▶).**

A pull-down menu appears.

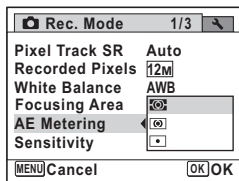
**4 Use the four-way controller (▲▼) to select the AE Metering setting.****5 Press the OK button.**

The setting is saved.

**6 Press the MENU button.**

The camera returns to capture status.



- When the shutter release button is pressed halfway, the brightness is metered and the exposure is determined.
- When the subject is outside the focusing area and you want to use spot AE metering, aim the camera at the subject and press the shutter release button halfway to lock the exposure, then compose your picture again and press the shutter release button fully.
- Depending on the selected shooting mode, the AE metering setting may not be changed. Refer to “Functions Available for Each Shooting Mode” (p.222) for details.
- If you change the [AE Metering] setting frequently, you can save time by assigning it to the Green button (p.117).

3

Saving the AE Metering setting p.123

## Setting the Sensitivity

You can select the sensitivity to suit the brightness of the surroundings.

Auto	The sensitivity is automatically adjusted by the camera. (Sensitivity 64 - 800)	
64	The lower the sensitivity, the less noise that affects the image. The shutter speed will be slower in low light conditions.	
100		
200		
400		
800		
1600		
3200		Higher sensitivity settings use faster shutter speeds in low light conditions to reduce camera shake, but the image may be affected by noise.
6400		

### 1 Press the MENU button in mode.

The [ Rec. Mode] menu appears.

### 2 Use the four-way controller ( ) to select [Sensitivity].

### 3 Press the four-way controller () .

A pull-down menu appears.

- 4 Use the four-way controller (▲▼) to change the sensitivity.**

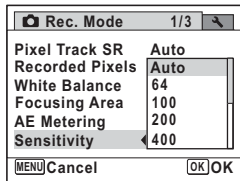

- 5 Press the OK button.**

The setting is saved.

- 6 Press the MENU button.**

The camera returns to capture status.



- When Sensitivity is set to 3200 or 6400, the number of recorded pixels is fixed at [5M] (2592×1944).
- When set to [Green] or [Movie] mode, only Auto (sensitivity 64 - 800) is available.
- When set to [Digital SR] mode, only Auto (sensitivity 64 - 6400) is available.
- When set to [Fireworks] mode, the sensitivity is fixed at its minimum setting.
- If you change the [Sensitivity] setting frequently, you can save time by assigning it to the Green button (p.117).

Saving the Sensitivity setting [p.123]

## Setting Blink Detection

This specifies whether Blink Detection works when you use the Face Recognition function. The default setting is  (On).

- 1 Press the MENU button in [Rec. Mode] mode.**

The [Rec. Mode] menu appears.

- 2 Use the four-way controller (▲▼) to select [Blink Detection].**

### 3 Use the four-way controller (◀▶) to select (On) or (Off).

- (On) Blink Detection function works.
- (Off) Blink Detection function does not work.

The setting is saved.

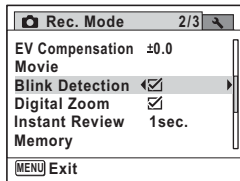

### 4 Press the MENU button.

The camera returns to capture status.

Blink Detection p.67

## Setting Pixel Track SR

You can set this function to correct for camera shake during shooting. If you set Pixel Track SR, the camera automatically corrects any camera shake in the images you shot. The default setting is [Auto].

### 1 Press the MENU button in mode.

The [ Rec. Mode] menu appears.

### 2 Use the four-way controller (▲▼) to select [Pixel Track SR].

### 3 Press the (▶) button.

A pull-down menu appears.

### 4 Use the four-way controller (▲▼) to select [Auto] or [Off].

- Auto Automatically corrects for camera shake.
- Off No correction for camera shake.

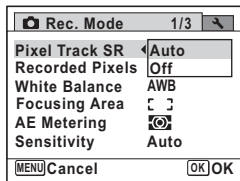

### 5 Press the OK button.

The setting is saved.

## 6 Press the MENU button.

The camera returns to capture status.



Pixel Track SR does not function in the following situations:

- When (Half-length Portrait), (Frame Composite), **WIDE** (Digital Wide) or (Digital Panorama) is selected as the shooting mode
- When (Self-timer), (Continuous Shooting) or (Burst Shooting) is selected as the drive mode
- When the flash discharges
- When the sensitivity is set to 1600 or higher
- During Movie or Voice Recording

## Setting the Instant Review

Use this setting to specify whether or not an Instant Review is displayed immediately after images are shot. The default setting is [1sec.] (displays the image for 1 second).

### 1 Press the MENU button in mode.

The [ Rec. Mode] menu appears.

### 2 Use the four-way controller (▲▼) to select [Instant Review].

### 3 Press the four-way controller (▶).

A pull-down menu appears.

### 4 Use the four-way controller (▲▼) to select [1sec.] or [Off].

- |       |   |
|-------|---|
| 1sec. | Instant Review is displayed for 1 second. |
| Off   | Instant Review is not displayed.          |

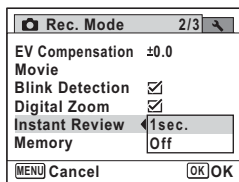

### 5 Press the OK button.

The setting is saved.

### 6 Press the MENU button.

The camera returns to capture status.



If the Blink Detection function worked when shooting, [Closed eyes have been detected.] is displayed for 3 seconds during Instant Review.

## Setting the Image Sharpness (Sharpness)

You can give the image sharp or soft outlines.

3

Taking Pictures

### 1 Press the MENU button in mode.

The [ Rec. Mode] menu appears.

### 2 Use the four-way controller (▲▼) to select [Sharpness].

### 3 Use the four-way controller (◀▶) to change the sharpness level.

- Soft
- Normal
- Sharp

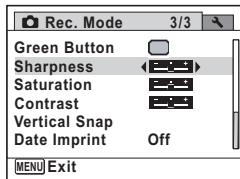

### 4 Press the MENU button.

The setting is saved and the camera returns to capture status.



If you change the [Sharpness] setting frequently, you can save time by assigning it to the Green button (p.117).

## Setting the Color Saturation (Saturation)



You can set the color saturation.

### 1 Press the MENU button in mode.

The [ Rec. Mode] menu appears.

### 2 Use the four-way controller (▲▼) to select [Saturation].

### 3 Use the four-way controller (◀▶) to change the saturation level.

-  Low
-  Normal
-  High

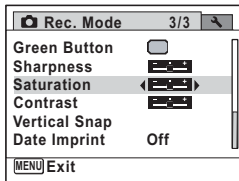

### 4 Press the MENU button.

The setting is saved and the camera returns to capture status.



If you change the [Saturation] setting frequently, you can save time by assigning it to the Green button (p.117).

## Setting the Image Contrast (Contrast)



You can set the image contrast level.

### 1 Press the MENU button in mode.

The [ Rec. Mode] menu appears.

### 2 Use the four-way controller (▲▼) to select [Contrast].

### 3 Use the four-way controller (◀▶) to change the contrast level.

-  Low
-  Normal
-  High

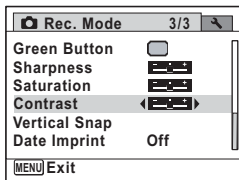

### 4 Press the MENU button.

The setting is saved and the camera returns to capture status.



If you change the [Contrast] setting frequently, you can save time by assigning it to the Green button (p.117).

## Setting the Date Imprint Function

You can choose whether to imprint the date and/or time when taking still pictures.

### 1 Press the **MENU** button in mode.

The [ Rec. Mode] appears.

### 2 Use the four-way controller ( ) to select [Date Imprint].

### 3 Press the four-way controller () .

A pull-down menu appears.

### 4 Use the four-way controller ( ) to select the Date Imprint details.

Choose from [Date], [Date & Time], [Time] or [Off].

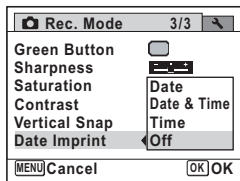

### 5 Press the **OK** button.

The setting is saved.

### 6 Press the **MENU** button.

The camera returns to capture status.



- The date and/or time imprinted with the Date Imprint function cannot be deleted.
- Note that if the printer or the image editing software is set to print the date and the images to be printed already have the date and/or time imprinted, the imprinted dates and/or times may overlap.



- **DATE** appears on the display in  mode when [Date Imprint] is set.
- The date and/or time are imprinted on the picture with the display style set in the [Date Adjust] screen (p.45).





## Calling Up a Specific Function

Assign a function to the Green button and recall it quickly by simply pressing the Green button. This is useful for going straight to the setting screens of frequently used functions.





The following functions can be assigned to the Green button:

-  (Green) Mode
- Recorded Pixels
- White Balance
- AE Metering
- Sensitivity
- EV Compensation
- Focusing Area
- Sharpness
- Saturation
- Contrast
- Voice Recording



- The Green button setting can be returned to its default setting by selecting [Reset] on the [ Setting] menu.
- The functions other than  (Green) Mode and Voice Recording can be set in the usual manner on the [ Rec. Mode] menu.
- You cannot save different settings for the same function on the Green button and on the [ Rec. Mode] menu.

### To Assign a Function to the Green Button

- 1 Press the MENU button in  mode.**  
The [ Rec. Mode] menu appears.
- 2 Use the four-way controller ( ) to select [Green Button].**
- 3 Press the four-way controller ().**  
A pull-down menu appears.

- 4** Use the four-way controller (▲▼) to choose a function and press the OK button.

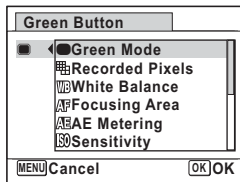

- 5** Press the MENU button.

The selected function is assigned to the Green button.

### To Use the Green Button

- 1** Press the Green button in  mode.

The function assigned to the Green button is called up.

- 2** Use the four-way controller (◀▶) to change the settings and press the OK button.

The camera returns to capture status.



If a function other than the  (Green) mode has been assigned to the Green button, the camera returns to the original screen if no operation is performed for 1 minute after the Green button is pressed.

# Recording Movies

## Recording a Movie

This mode enables you to record movies. Sound is recorded at the same time.

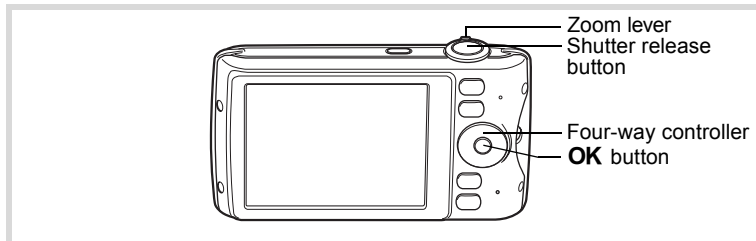

**1 Press the four-way controller (▼) in mode.**  
The Capture Mode Palette appears.

**2 Use the four-way controller (▲▼◀▶) to select (Movie).**



**3 Press the OK button.**

(Movie) mode is selected and the camera returns to capture status.

The following information appears on the display.

- 1 Movie mode icon
- 2 Recording indicator (blinks during recording)
- 3 Remaining recordable time
- 4 Focus frame (does not appear during recording)
- 5 Movie shake reduction function icon

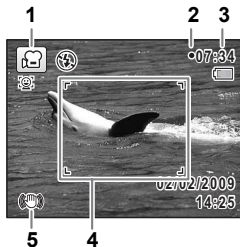

You can change the captured area by turning the zoom lever to the left or right.

- Right (▲) Enlarges the subject.
- Left (▼) Widens the area that is captured by the camera.

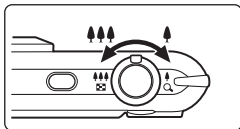

#### 4 Press the shutter release button fully.

Recording starts. You can continue recording until the built-in memory or the SD Memory Card is full, or the size of the recorded movie reaches 2 GB.

#### 5 Press the shutter release button fully.

Recording stops.

Playing Back a Movie p.127







- The flash does not discharge in (Movie) mode.
- The focus mode can be changed before recording starts.
- When the focus mode is set to **MF** (Manual Focus), you can adjust the focus before recording starts.
- You can use the optical zoom only before recording, while the digital zoom is available both before and during recording.
- Changing the display mode by pressing the **OK/DISPLAY** button while recording a movie will not display the histogram.
- When the shooting mode is set to (Movie), Face Priority is automatically set to on. You can select Smile Capture or Face Priority Off by pressing the button before starting recording a movie (p.70). When Smile Capture function is activated, movie recording starts automatically when the camera recognizes the subject's smile. However, depending on the condition of the recognized faces, movie recording may not start automatically because the Smile Capture function may not work. If this happens, press the shutter release button to start movie recording.

#### Keeping the Shutter Release Button Pressed



If you keep the shutter release button pressed for more than one second, recording will continue as long as you keep the button pressed. Shooting stops when you take your finger off the shutter release button.

## Selecting the Recorded Pixels and Frame Rate for Movies

You can choose the recorded pixels and frame rate settings for movies. The more pixels there are, the clearer the details and the bigger the file size. The more frames per second, the better the quality of the movie, but the file size becomes larger.

Setting	Recorded Pixels	Frame Rate	Use
	1280×720	15 fps	Records images in HDTV format (default setting).
	640×480	30 fps	Suitable for viewing on a TV or computer screen. Movement is recorded smoothly.
	640×480	15 fps	Suitable for viewing on a TV or computer screen. Increases the total recording time by making the file size smaller.
	320×240	30 fps	Suitable for posting on a website or attaching to e-mail. Movement is recorded smoothly.
	320×240	15 fps	Suitable for posting on a website or attaching to e-mail. Increases the total recording time by making the file size smaller.

\* The frame rate (fps) indicates the number of frames per second.

- 1 Press the MENU button in  mode.**  
The [ Rec. Mode] menu appears.
- 2 Use the four-way controller (▲▼) to select [Movie].**
- 3 Press the four-way controller (▶).**  
The [Movie] screen appears.
- 4 Use the four-way controller (▲▼) to select [Recorded Pixels].**
- 5 Press the four-way controller (▶).**  
A pull-down menu appears.

- 6** Use the four-way controller (▲▼) to change the number of recorded pixels and frame rate.

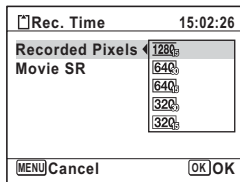

- 7** Press the **OK** button.

The setting is saved.

- 8** Press the **MENU** button twice.

The camera returns to capture status.

## Setting the Movie SR (Movie Shake Reduction) Function

In **Movie** mode, you can compensate for camera shake while you are recording a movie with the Movie SR (Movie Shake Reduction) function.

- 1** Press the **MENU** button in **Movie** mode.

The [Movie Rec. Mode] menu appears.

- 2** Use the four-way controller (▲▼) to select [Movie].

- 3** Press the four-way controller (▶).

The [Movie] screen appears.

- 4** Use the four-way controller (▲▼) to select [Movie SR].

- 5** Use the four-way controller (◀▶) to select  (On) or  (Off).

- (On) Automatically corrects for camera shake.
- (Off) No correction for camera shake.

The setting is saved.

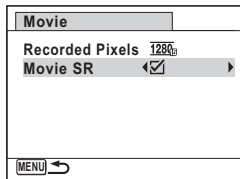

- 6** Press the **MENU** button twice.







The camera returns to capture status.

# Saving the Settings (Memory)

The Memory function is for saving the current camera settings when the camera is turned off.

For some camera settings, the Memory function is always set to  (On) (the settings are saved when the camera is turned off), while for others you can choose on or off (to choose whether the settings are saved or not when the camera is turned off). The items which can be set to  (On) or  (Off) in the Memory function are shown in the table below. (Items not listed here are always saved in the selected settings when the camera is turned off.)

If you select  (On), the settings will be saved in the status they were in immediately before the camera was turned off. If you select  (Off), the settings will be reset to the defaults when the camera is turned off. The table below also shows whether the Memory default setting for each item is on or off.

Item	Description	Default Setting	Page
Face Priority	A Face Recognition mode set by using the  button	<input type="checkbox"/>	p.70
Flash Mode	The flash mode set with the four-way controller (◀)	<input checked="" type="checkbox"/>	p.99
Drive Mode	The drive mode set with the four-way controller (▲)	<input type="checkbox"/>	p.91 p.92
Focus Mode	The focus mode set with the four-way controller (▶)	<input type="checkbox"/>	p.101
Zoom Position	The zoom position set with the zoom lever	<input type="checkbox"/>	p.76
MF Position	The manual focus position set with the four-way controller (▲▼)	<input type="checkbox"/>	p.102
White Balance	The [White Balance] setting on the [  Rec. Mode] menu	<input type="checkbox"/>	p.107
Sensitivity	The [Sensitivity] setting on the [  Rec. Mode] menu	<input type="checkbox"/>	p.110
EV Compensation	The [EV Compensation] setting on the [  Rec. Mode] menu	<input type="checkbox"/>	p.106
AE Metering	The [AE Metering] setting on the [  Rec. Mode] menu	<input type="checkbox"/>	p.109
Digital Zoom	The [Digital Zoom] setting on the [  Rec. Mode] menu	<input checked="" type="checkbox"/>	p.77
DISPLAY	The information display mode set with the <b>OK/DISPLAY</b> button	<input type="checkbox"/>	p.20
File No.	If a new SD Memory Card is inserted when On has been selected, file numbers are assigned sequentially	<input checked="" type="checkbox"/>	—

---

**1** Press the **MENU** button in **📷** mode.

The [📷 Rec. Mode] menu appears.

---

**2** Use the four-way controller (▲▼) to select [Memory].

---

**3** Press the four-way controller (▶).

The [Memory] screen appears.

---

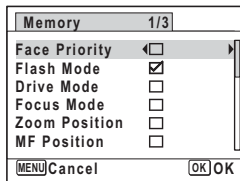
**4** Use the four-way controller (▲▼) to choose an item.

---

**5** Use the four-way controller (◀▶) to select  (On) or  (Off).

---

**6** Press the **OK** button.

The setting is saved.

---

**7** Press the **MENU** button.

The camera returns to capture status.

# 4 Playing Back and Deleting Images

---

Playing Back Images .....	126
Deleting Images .....	142
Connecting the Camera to AV Equipment .....	151

# Playing Back Images

## Playing Back Still Pictures

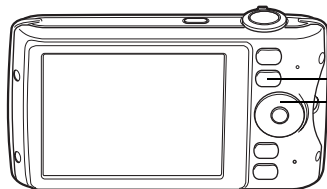

▶ button  
Four-way controller

4

Playing Back and Deleting Images

- 1 Press the ▶ button after taking a picture.

The camera enters the ▶ mode and the image appears on the display. Displaying one image in full in ▶ mode (▶ mode default setting) is called single-image display.

File number



### To Play Back the Previous or Next Image

- 2 Press the four-way controller (◀▶).

The previous or next image appears.

### To Delete the Displayed Image

Press the  button while the image is displayed to display the Delete screen. Press the four-way controller (▲) to select [Delete] and press the **OK** button.





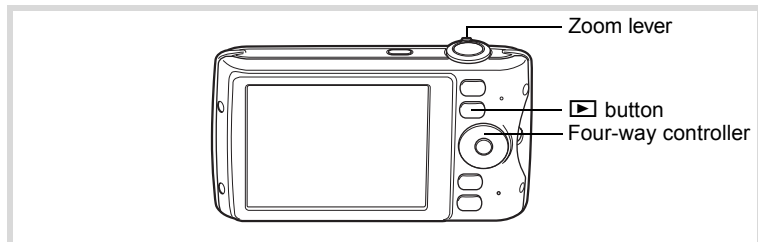

For information on other deletion procedures  p.142

## Playing Back a Movie

You can play back the movies you have taken. The sound is played back at the same time.







**1** Enter the  mode and use the four-way controller ( ) to choose the movie you want to play back.

**2** Press the four-way controller ().  
Playback starts.



The following operations can be performed during playback.

Four-way controller (  )	Pauses playback
Zoom lever to the right (  )	Increases the volume
Zoom lever to the left (  )	Reduces the volume
Four-way controller (  )	Fast-forwards playback while the button is held down
Four-way controller (  )	Plays back in reverse
	Fast-reverses playback while the button is held down

The following operations can be performed while playback is paused.

Four-way controller (  )	Resumes playback
Four-way controller (  )	Forwards the frame
Four-way controller (  )	Reverses the frame

**3** Press the four-way controller ().  
Playback stops.

## Multi-Image Display

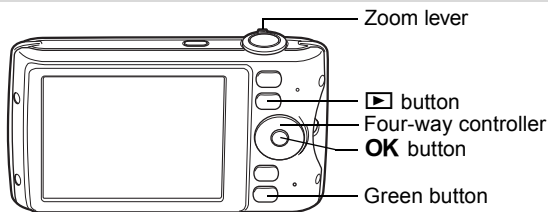

### Four-Image Display/Nine-Image Display

4

You can display four or nine thumbnails of captured images at a time.

#### 1 In ▶ mode, turn the zoom lever to the left (☒).

The four-image display appears showing a page consisting of four thumbnail images. Turn the zoom lever to the left (☒) again to switch to nine-image display.

A page consisting of four or nine thumbnail images appears. The displayed images change four or nine images at a time page by page.

Use the four-way controller (▲▼◀▶) to move the frame. If there are too many images to fit on one page, pressing the four-way controller (▲◀) while the image ① is selected will display the previous page. Similarly, if you choose image ② and press the four-way controller (▼▶), the next page appears.

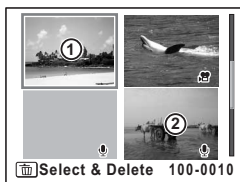
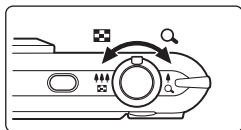

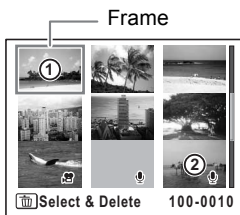

Four-Image Display





Nine-Image Display

The icons that appear on the images indicate the following:



(No icon)	Still picture without sound
 (with image)	Still picture with sound
	Movie (the first frame appears)
 (without image)	Sound file only

Press the **OK** button to switch to single-image display of the selected image.

Press the  button to switch to  mode.

## Folder Display/Calendar Display

In nine-image display, turn the zoom lever to the left () to switch to folder display or calendar display. Press the Green button to switch between folder display and calendar display.

- 1** In  mode, turn the zoom lever to the left () twice.

The screen changes to nine-image display.

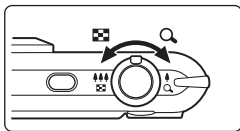



- 2** Turn the zoom lever to the left ().

The screen changes to folder display or calendar display.

### Folder display

The list of folders with recorded images and sound files appears.

Use the four-way controller () to move the frame.

Press the **OK** button or turn the zoom lever to the right () to display the images in the selected folder in nine-image display.

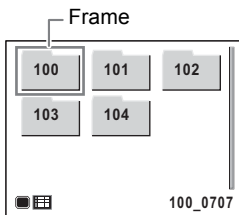

## Calendar display

Recorded images and sound files are displayed by date in calendar format. The first image recorded on a date is displayed for that date on the calendar.

 appears for dates on which a sound file was the first recorded file.

Use the four-way controller () to move the frame to a different date.

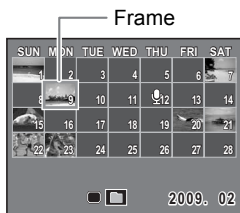

Turn the zoom lever to the right () to display the images for a date in nine-image display.

Select a date and press the **OK** button to switch to single-image display of the first image recorded on that date.





4



- Press the **MENU** button in folder display or calendar display to switch to nine-image display.
- Press the  button or half-press the shutter release button in folder display or calendar display to switch to  mode.

## Using the Playback Function



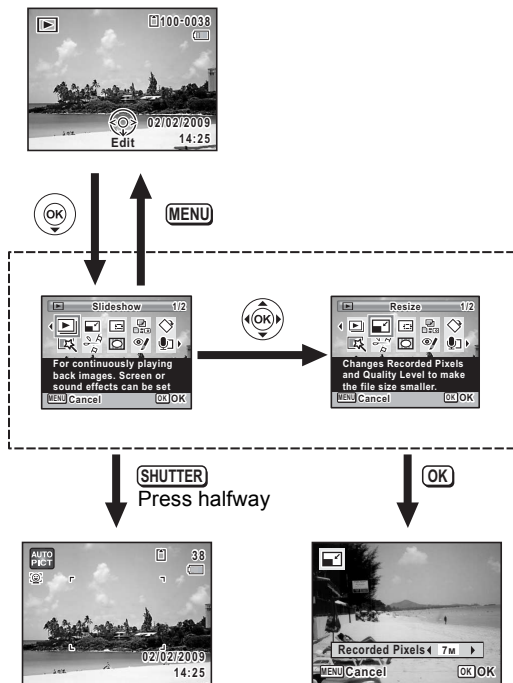











- 1 Press the four-way controller () in  mode.**  
The Playback Mode Palette appears.
- 2 Use the four-way controller () to choose an icon.**  
The guide for the selected function appears below.
- 3 Press the **OK** button.**  
The playback function is recalled.



Closes the Playback Mode Palette and goes to mode.



Goes to the screen for selected playback function.

## Playback Mode Palette

Playback Mode		Description	Page
	Slideshow	For continuously playing back images. Screen or sound effects can be set.	p.133
	Resize	Changes Recorded Pixels and Quality Level to make the file size smaller.	p.154
	Cropping	For cropping images to the size you like. Saved as a new image.	p.155
	Image/Sound Copy	For copying images and sounds between the built-in memory and SD Memory Card.	p.166
	Image Rotation	Rotates captured images. Useful when viewing vertical images on a TV.	p.138
	Digital Filter	For modifying images with a Color filter or Soft filter.	p.156
	Save as Still Image	For saving one frame from a movie as a still picture.	p.164
	Divide Movies	For dividing a movie into two.	
	Frame Composite	For composing an image with a frame. Select Overwrite or Save as to save.	p.161
	Red-eye Compensation	For compensating red-eye. May not work due to the condition of the image.	p.160
	Voice Memo	Attaches sound to images. Recording is possible till the memory card is full.	p.181
	Protect	Protects images and sounds from accidental deletion. Formatting will delete.	p.148
	DPOF	For the print settings. Useful when printing at a printing service.	p.168
	Favorites	Sets images as favorites. Copies to internal memory and resizes to [640].	p.135
	Image Recovery	For recovering image and sound files which were accidentally deleted.	p.147
	Start-up Screen	For setting a captured image as the Start-up Screen.	p.197





## Slideshow

You can play back recorded images one after another.

**1** Enter the  mode and use the four-way controller ( ) to choose the image to start the slideshow with.

**2** Press the four-way controller (.

The Playback Mode Palette appears.

**3** Use the four-way controller (   ) to select  (Slideshow).



**4** Press the **OK** button.

The slideshow setting screen appears.

**5** Press the **OK** button.

The slideshow starts.

Pressing the **OK** button during the slideshow pauses the slideshow. To resume the slideshow, press the **OK** button again.

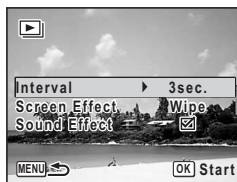

**6** Press any button other than the **OK** button.

The slideshow stops.

## To Set the Slideshow Conditions

You can set the playback interval and also a screen effect and sound effect for when one image changes to the next.

- 1 Use the four-way controller (▲▼) to select [Interval] in Step 5 on p.133.**

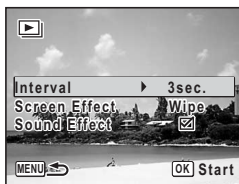

- 2 Press the four-way controller (▶).**

A pull-down menu appears.

- 3 Use the four-way controller (▲▼) to change the interval and press the OK button.**

Choose from [3sec.], [5sec.], [10sec.], [20sec.] or [30sec.].

- 4 Use the four-way controller (▲▼) to select [Screen Effect].**

After selecting [Screen Effect], press the four-way controller (▶). A pull-down menu appears with the following items. Use the four-way controller (▲▼) to select an item and press the **OK** button.

Wipe	The next image slides over the previous one from left to right
Checker	The next image appears in small square mosaic blocks
Fade	The current image gradually fades out and the next image fades in
Off	No effect

- 5 Use the four-way controller (▲▼) to select [Sound Effect].**

- 6 Use the four-way controller (◀▶) to select  (On) or  (Off).**

Except when the [Screen Effect] is set to Off, you can choose  (On) or  (Off) for the sound that is played when one image changes to the next.

- 7 Press the OK button.**

The slideshow starts using the selected interval and effect.



- The slideshow will continue until you press any button other than the **OK** button.
- Movies or pictures with sound will be played through to the end before the next picture is played back, regardless of the interval setting. However, pressing the four-way controller (▶) while playing back a movie or a picture with sound skips to the next image.
- Sound files made in Voice Recording are not played back in the slideshow.
- Panorama images will be scrolled for display from left to right in 4 seconds before the next picture is played back, regardless of the Interval or Screen Effect setting.

Connecting the Camera to AV Equipment p.151

## Registering/Playing Back Images in the FAVORITE Folder

You can select your favorite shots from the images you have captured and register them in the FAVORITE folder for easy playback later.

### To Register Images in the FAVORITE Folder



You can only register images captured with this camera in the FAVORITE folder. You cannot register the following types of files.

- Movies/sound
- Images captured at the 2.1M (1920×1080) size
- Digital Wide/Panorama images
- Images saved as still pictures from the movies recorded at the 1280s size.

**1** Enter the mode and use the four-way controller (◀▶) to select the image to be registered as a favorite.

**2** Press the four-way controller (▼).

The Playback Mode Palette appears.

- 3** Use the four-way controller (▲▼◀▶) to select  (Favorites).



- 4** Press the OK button.

The screen for selecting [Playback Favorites] or [Register as Favorite] appears.

- 5** Use the four-way controller (▲▼) to select [Register as Favorite].



- 6** Press the OK button.

The message [Register this image as a Favorite] appears.

To register another image, use the four-way controller (◀▶) to select the image.

- 7** Use the four-way controller (▲▼) to select  (On) or  (Off).

- (On) Register as favorite.
- (Off) Do not register as favorite.

To register other images, repeat Steps 6 and 7.



- 8** Press the OK button.

The image is registered as a Favorite.



- Images registered as Favorites are copied at the **640** (640×480) size and saved to the FAVORITE folder in the built-in memory. (The source images are left at their original size.)
- Images can be registered as Favorites until the built-in memory becomes full.
- All of the images registered in the FAVORITE folder are deleted if the built-in memory is formatted when an error occurs.

## To Play Back Images in the FAVORITE Folder

Use this procedure to play back the images you have registered in the FAVORITE folder. As well as viewing images one at a time, you can also view them using 4-image or 9-image display or as a slideshow.

### 1 Select [Playback Favorites] in Step 5 on p.136.

The first registered image appears.



### 2 Use the four-way controller (◀▶) to select images.

The table below shows the actions available during image playback.



OK button	Starts the slideshow. <ul style="list-style-type: none"><li>Interval: 3 seconds; Screen effect: Wipe; Sound effect: On for playback.</li><li>Plays registered images once in sequence and then stops.</li><li>Button actions during the slideshow are the same as for normal slideshows (p.133).</li></ul>
Green button	Deletes one image or all images.
Zoom lever to the left (☒)	Four-/nine-image display <ul style="list-style-type: none"><li>Pressing the Green button during four-/nine-image display switches to the Select &amp; Delete screen.</li></ul>

### 3 Press the MENU button three times.



- You cannot play back images registered in the FAVORITE folder using the regular playback mode or edit them using the Playback Mode Palette.
- You cannot specify DPOF settings for images registered in the FAVORITE folder, or print those images by connecting the camera directly to a printer (PictBridge).

## Rotating the Image

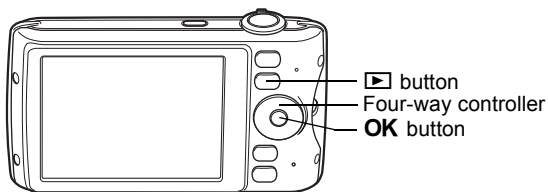

### 1 Press the button after taking a picture.

The image appears on the display.

### 2 Press the four-way controller () .

The Playback Mode Palette appears.

### 3 Use the four-way controller ( ) to select (Image Rotation) and press the OK button.

The rotation selection screen (0°, Right 90°, Left 90°, or 180°) appears.

### 4 Use the four-way controller ( ) to choose the rotation direction and press the OK button.

The rotated image is saved.

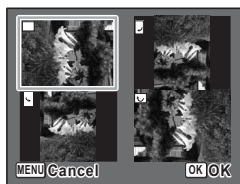

- Panoramic images and movies cannot be rotated.
- Protected images can be rotated, but they cannot be saved in a rotated state.

## Zoom Playback

You can magnify an image up to ten times.

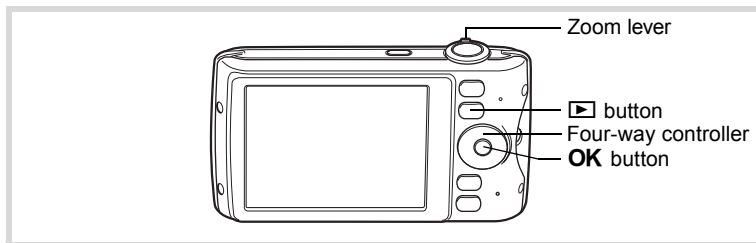

**1** Enter the mode and use the four-way controller ( ) to choose the image you want to magnify.

**2** Turn the zoom lever to the right ().

The image is magnified ( $\times 1.1$  to  $\times 10$ ). Continuing to turn the zoom lever to the right () changes the magnification continuously.

You can use the + mark of the guide at the bottom left of the screen to check which portion of the image is magnified.

The following operations can be performed while the magnified image is displayed.

Four-way controller (   )	Moves the position to be magnified
Zoom lever to the right ()	Makes the image bigger (max. $\times 10$ )
Zoom lever to the left ()	Makes the image smaller (min. $\times 1.1$ )

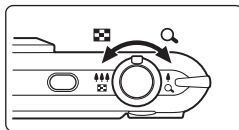

Guide

**3** Press the OK button.

The image returns to single-image display.





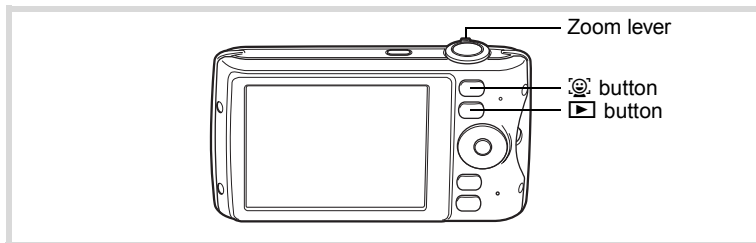

Movies cannot be magnified.

## Zoom In on the Subject's Face Automatically (Face Close-up Playback)

You can enjoy playing back images with the subject's faces zoomed up simply by pressing the  button (Face close-up playback) if the Face Recognition function operated when the images were taken.



4

- 1** Enter the  mode and use the four-way controller ( ) to choose the image you want to magnify.
- 2** Confirm that the  icon is displayed in the image and press the  button.

The image is magnified around the face first recognized when the image was taken.



If multiple faces were recognized when the image was taken, the subject's faces are zoomed up on each time the  button is pressed in order of the recognition during shooting.



The following operations can be performed during Face close-up playback mode.

Zoom lever to the right (Q)	Zooms up on the subject being displayed for face close-up playback at an equal or slightly larger magnification ratio.
Zoom lever to the left (W)	Zooms up on the subject being displayed for face close-up playback at an equal or slightly smaller magnification ratio.

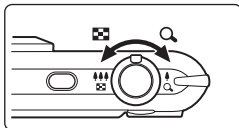

**3**

### Press the OK button.

The image returns to single-image display.



The magnification ratio for Face close-up playback may differ depending on the conditions such as the size of the face recognized when shooting.

**4**

# Deleting Images

Delete images and sound files with mistakes or that you do not want to keep.

## When images or sound files are inadvertently deleted

Deleted images and sound files can be recovered with the Optio P70 (p.147). Deleted images and sound files can be recovered even if the camera has been turned off after deletion as long as the SD Memory Card has not been removed. However, deleted images and sound files cannot be recovered after operations to write data such as taking pictures, recording movies, protecting images, saving DPOF settings, resizing images, cropping images, registering images as Favorites, deleting images saved as Favorites, or formatting have been performed.

4

## Deleting a Single Image/Sound File

You can delete a single image or sound file.



Protected images and sound files cannot be deleted (p.148).

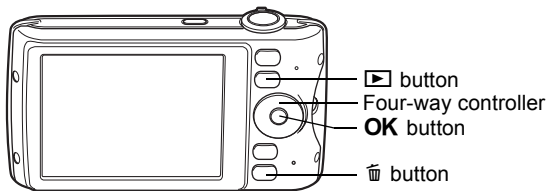

- 1 Enter the ▶ mode and use the four-way controller (◀▶) to choose the image/sound file you want to delete.**
- 2 Press the 🗑 button.**  
A confirmation screen appears.

- 3** Use the four-way controller (▲▼) to select [Delete].



- 4** Press the OK button.

The image or sound file is deleted.

Recovering Deleted Images p.147

### To Delete a Sound File

If sound (voice memo) has been recorded with an image (p.181), you can delete the sound without deleting the image.

- 1** Enter the mode and use the four-way controller (◀▶) to choose the image with sound.
- 2** Press the button.  
A confirmation screen appears.
- 3** Use the four-way controller (▲▼) to select [Delete Sound].

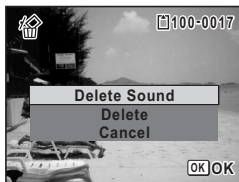

- 4** Press the OK button.

The sound file is deleted.



- Select [Delete] in Step 3 above to delete both the image and sound file.
- You cannot delete only the sound in a movie.

## Deleting Selected Images and Sound Files



You can delete several images/sound files selected from the four-/nine-image display at once.

**Caution:**

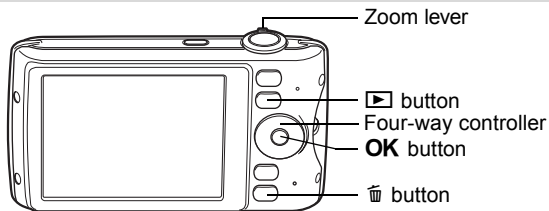
Protected images and sound files cannot be deleted (p.148).



4

- 1 In  mode, turn the zoom lever to the left () once or twice.**

Four-image display or Nine-image display appears.

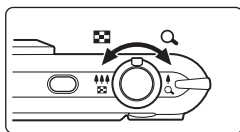

- 2 Press the  button.**

 appears on the images and sound files.



- 3** Use the four-way controller (▲▼◀▶) to choose the images and sound files that you want to delete and press the OK button.

☑ appears on the selected images and sound files.



If you select an image and turn the zoom lever to the right (Q), the selected image appears in single-image display as long as the lever is turned, enabling you to check whether you really want to delete it or not. (The display returns to four-/nine-image display when you release the lever.) However, protected images cannot be displayed in single-image display.

- 4** Press the  button.

A confirmation dialog appears.

- 5** Use the four-way controller (▲▼) to select [Select & Delete].



- 6** Press the OK button.

The selected images and sound files are deleted.

## Deleting All Images and Sound Files

You can delete all the images and sound files at once.



Protected images and sound files cannot be deleted (p.148).

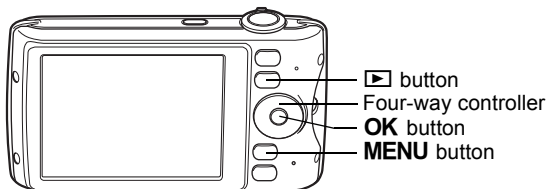

4

### 1 Press the **MENU** button in ▶ mode.

The [Setting] menu appears.

When you press the **MENU** button in 📷 mode, press the four-way controller (▶) once.

### 2 Use the four-way controller (▲▼) to select [Delete all images].

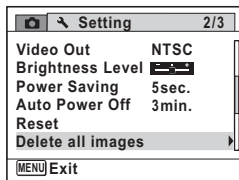

### 3 Press the four-way controller (▶).

A confirmation dialog appears.

### 4 Use the four-way controller (▲▼) to select [Delete All].

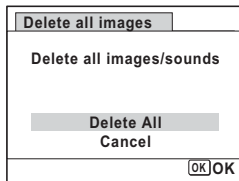

## 5 Press the OK button.

All the images and sound files are deleted.

## Recovering Deleted Images

You can recover images or sound files that were taken with this camera and then deleted.



After deleting an image, once operations to write data such as taking pictures, recording movies, protecting images, saving DPOF settings, resizing images, cropping images, registering images as Favorites, deleting images saved as Favorites, or formatting have been performed, or the SD Memory Card has been removed, the message [No image to be processed] appears in Step 3 and the deleted images and sound files cannot be recovered.

## 1 After deleting a file, press the four-way controller (▼).

The Playback Mode Palette appears.

## 2 Use the four-way controller (▲▼◀▶) to select (Image Recovery).



## 3 Press the OK button.

The number of recoverable images appears.

If there are no recoverable images, the message [No image to be processed] appears.

## 4 Use the four-way controller (▲▼) to select [Recover].



## 5 Press the OK button.

The files are recovered.



- Recovered images and sound files have the same file name as before they were deleted.
- Up to a maximum of 999 deleted image files can be recovered.
- The images deleted from the “Favorites” cannot be recovered.

## Protecting Images and Sound Files from Deletion (Protect)

You can protect stored images and sound files from being accidentally deleted.

4

Playing Back and Deleting Images

### 1 Enter the mode and use the four-way controller ( ) to choose the image you want to protect.

### 2 Press the four-way controller () .

The Playback Mode Palette appears.

### 3 Use the four-way controller ( ) to select (Protect).



### 4 Press the OK button.

The screen for selecting [Single Image/Sound] or [All Images/Sounds] appears.

### 5 Use the four-way controller ( ) to select [Single Image/Sound].



## 6 Press the OK button.

The message [Protect this image/sound] appears.

To protect another image or sound file, use the four-way controller (◀▶) to select another image or sound file.

## 7 Use the four-way controller (▲▼) to select [Protect].



## 8 Press the OK button.

The selected image or sound file is protected.



- To cancel the Protect setting, select [Unprotect] in Step 7.
-  appears on the top left of the protected images and sound files during playback.
- The maximum number of images and sound files you can protect in succession with [Single Image/Sound] cannot exceed 99.

## To Protect All Images and Sound Files

### 1 Select [All Images/Sounds] in Step 5 on p.148.

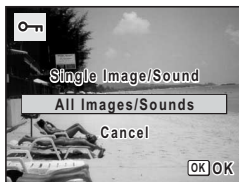

### 2 Press the OK button.

**3** Use the four-way controller (▲▼) to select [Protect].

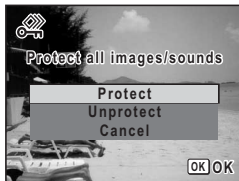

**4** Press the **OK** button.

All the images and sound files are protected.



Protected images and sound files will be deleted when the SD Memory Card is formatted (p.184).

4



To cancel the Protect setting on all your images and sound files, select [Unprotect] in Step 3.

# Connecting the Camera to AV Equipment

By using the supplied AV cable (I-AVC7), you can capture and play back images on equipment with a video IN jack, such as a TV.

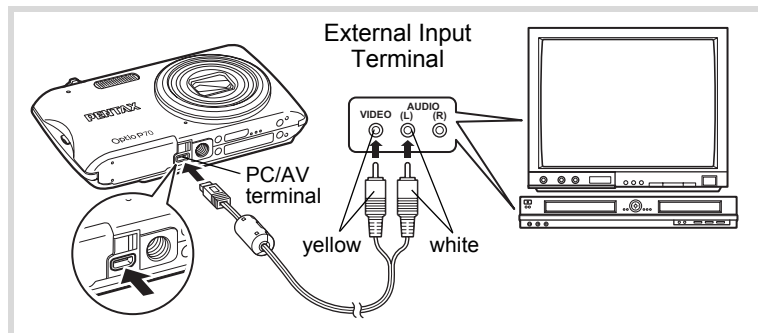

- 1 Turn the AV device and camera off.**
- 2 Connect the AV cable to the PC/AV terminal of the camera.**

Connect the terminal of the AV cable with pointing toward the ◀ on the PC/AV terminal on the bottom of the camera.
- 3 Connect the other ends of the AV cable (yellow: video, white: audio) to the video input terminal and audio input terminal of the AV device.**

When using stereo sound equipment, insert the sound terminal into the L (white) terminal.
- 4 Turn the AV device on.**

When the device that the camera is connected to and the device that plays back images are different, turn both devices on.  
When viewing images on AV equipment with multiple video input terminals (such as a TV), refer to the operation manual of the device and select the video input terminal to which the camera is connected.

## 5 Turn the camera on.



- It is recommended to use the optional AC adapter kit K-AC88 if you intend to use the camera for a long time (p.33).
- Depending on the country or region, images and sound files may fail to be played back if the video output format is set different from the one in use there. If this happens, change the video output format setting (p.193).
- The camera display turns off while the camera is connected to AV equipment.
- The volume cannot be adjusted with the zoom lever while the camera is connected to AV equipment.

# **5 Editing and Printing Images**

---

<b>Editing Images .....</b>	<b>154</b>
<b>Setting the Printing Service (DPOF) .....</b>	<b>168</b>
<b>Printing Using PictBridge .....</b>	<b>171</b>

## Changing the Image Size (Resize)

By changing the size and quality of a selected image, you can make the file size smaller than the original. You can use this function to continue taking pictures when the SD Memory Card or the built-in memory is full, by making the images smaller and overwriting the original images to make more space available.



- Images taken with 2.1M (1920×1080), panoramic images and movies cannot be resized.
- You cannot select a larger resolution than that of the original image.

**1** Enter the mode and use the four-way controller (◀▶) to choose the image you want to resize.

**2** Press the four-way controller (▼).  
The Playback Mode Palette appears.

**3** Use the four-way controller (▲▼◀▶) to select (Resize).



**4** Press the OK button.  
The screen for choosing the image size appears.

**5** Use the four-way controller (◀▶) to select [Recorded Pixels].



**6 Press the OK button.**

A confirmation dialog for overwriting the image appears.

When the selected image is protected, the resized image will be saved as a new image without the following confirmation dialog displayed on the screen.

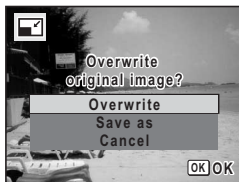
**7 Use the four-way controller (▲▼) to select [Overwrite] or [Save as].****8 Press the OK button.**

The resized image is saved.

## Cropping Images

You can delete the unwanted part of a picture and save the cropped image as a separate image.



Images taken with 2.1m (1920×1080), panoramic images and movies cannot be cropped.

**1 Enter the  mode and use the four-way controller (◀▶) to choose the image you want to crop.****2 Press the four-way controller (▼).**

The Playback Mode Palette appears.

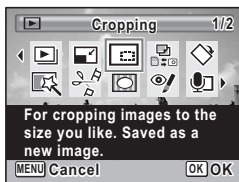
**3 Use the four-way controller (▲▼◀▶) to select  (Cropping).**

## 4 Press the OK button.

The cropping screen appears.

The largest size of cropped image is shown with a green frame on the screen. The cropped image cannot be larger than this cropping frame size.

## 5 Choose the cropping area.

The following operations move the green frame and set the area for cropping on the screen.

Zoom lever	Changes the size of the cropped section
Four-way controller (▲▼◀▶)	Moves the cropping position up, down, left and right
Green button	Rotates the cropping frame <ul style="list-style-type: none"> <li>The button is only displayed when the cropping frame size can be rotated.</li> </ul>

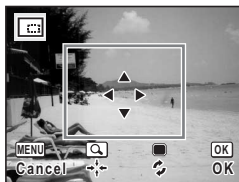

## 6 Press the OK button.

The cropped image is saved with a new file name.

The number of recorded pixels is selected automatically according to the size of the cropped section.

## Using the Digital Filters

This mode lets you change the color tones and perform special processing on a selected image.

B&W filter	Processes the image using the B&W filter.
Sepia filter	Processes the image using the sepia filter.
Color filter	Processes the image using the selected color filter. You can choose from six filters: red, pink, purple, blue, green, and yellow.
Color extraction filter	Processes the image using the selected color extraction filter. You can choose from three filters: red, green, and blue.
Soft filter	Processes the image into a soft image.
Brightness Filter	Adjusts the brightness of the image.



Panoramic images, movies or images taken with another camera cannot be edited using Digital Filter function. An error message appears if you choose this function from the Playback Mode Palette and press the **OK** button.

**1** Enter the mode and use the four-way controller (**◀▶**) to choose the image you want to edit.

**2** Press the four-way controller (**▼**).  
The Playback Mode Palette appears.

**3** Use the four-way controller (**▲▼◀▶**) to select (Digital Filter).

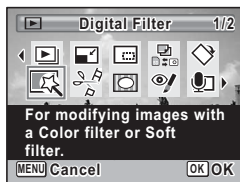

**4** Press the **OK** button.  
The digital filter selection screen appears.

- 1 B&W filter
- 2 Sepia filter
- 3 Color filter
- 4 Color extraction filter
- 5 Soft filter
- 6 Brightness Filter



### To Select a B&W Filter, Sepia Filter or Soft Filter

**5** Use the four-way controller (**▲▼**) to choose a digital filter.  
The preview image of the results of the filter effect appears.

**6** Press the **OK** button.  
A confirmation dialog for overwriting the image appears.  
When the selected image is protected, the processed image will be saved as a new image without the following confirmation dialog displayed on the screen.

- 7** Use the four-way controller (▲▼) to select [Overwrite] or [Save as].



- 8** Press the OK button.

The images processed with the filter are saved.

## To Select a Color Filter or Color Extraction Filter

- 5** Use the four-way controller (▲▼) to choose a digital filter type.

- 6** Use the four-way controller (◀▶) to choose the effect.

The color filter changes in the following sequence each time you press the four-way controller (▶): Red, Pink, Purple, Blue, Green, Yellow. The color extraction filter changes in the following sequence each time you press the four-way controller (▶): Red, Green, Blue.

- 7** Press the OK button.

A confirmation dialog for overwriting the image appears. When the selected image is protected, the processed image will be saved as a new image without the following confirmation dialog displayed on the screen.

- 8** Use the four-way controller (▲▼) to select [Overwrite] or [Save as].



- 9** Press the OK button.

The images processed with the filter are saved.

## To Select a Brightness Filter

**5** Use the four-way controller (▲▼) to choose a digital filter you want to use.

**6** Use the four-way controller (◀▶) to adjust the effect.

The brightness increases each time you press the four-way controller (▶) and decreases each time you press the four-way controller (◀).



**7** Press the OK button.

A confirmation dialog for overwriting the image appears. When the selected image is protected, the processed image will be saved as a new image without the following confirmation dialog displayed on the screen.

**8** Use the four-way controller (▲▼) to select [Overwrite] or [Save as].



**9** Press the OK button.

The images processed with the filter are saved.

## Red-eye Compensation

You can correct images where the flash has caused the subject to appear with red eyes.



- The red-eye compensation function cannot be used on panoramic images, movies or on images where red eyes cannot be detected on the camera. An error message appears in Step 4.
- The red-eye compensation function can only be used with still pictures taken with this camera.

**1** Enter the mode and use the four-way controller (◀▶) to choose the image you want to correct.

**2** Press the four-way controller (▼).  
The Playback Mode Palette appears.

**3** Use the four-way controller (▲▼◀▶) to select (Red-eye Compensation).

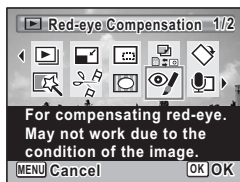

**4** Press the **OK** button.

A confirmation dialog for overwriting the image appears. When the selected image is protected, the corrected image will be saved as a new image without the following confirmation dialog displayed on the screen.

**5** Use the four-way controller (▲▼) to select **[Overwrite]** or **[Save as]**.

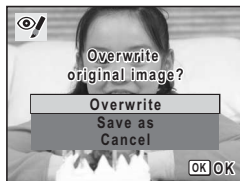

**6** Press the **OK** button.  
The edited image is saved.

## Adding a Frame (Frame Composite)

This function lets you add a decorative frame to still pictures. There are 90 frames already stored in the camera.



The Frame Composite function cannot be used on images taken with **2.1M** (1920×1080), panoramic images, movies or images of size **3M** (2048×1536) or smaller. An error message appears in Step 4.

**1** Enter the mode and use the four-way controller (◀▶) to choose the image to which you want to add a frame.

**2** Press the four-way controller (▼).  
The Playback Mode Palette appears.

**3** Use the four-way controller (▲▼◀▶) to select (Frame Composite).

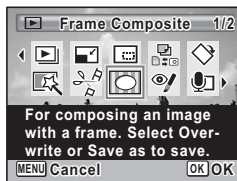

**4** Press the **OK** button.  
The 9-frame display of the frame selection screen appears.

**5** Use the four-way controller (▲▼◀▶) to choose a frame.

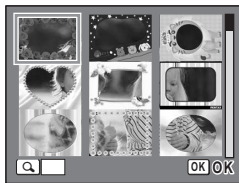

## 6 Turn the zoom lever to the right (Q).

The selected frame appears in single-image display.

You can choose another frame using either of the following operations.

Four-way controller (◀▶)	Press to choose a different frame.
Zoom lever to the left (Q)	Turn to return to the 9-frame display of the frame selection screen, and then perform Step 5 to choose a different frame.

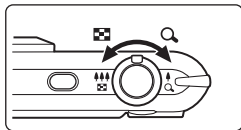

## 7 Press the OK button.

The frame position and size adjustment screen appears.

You can adjust the image using either of the following operations.

Four-way controller (▲▼◀▶)	Press to adjust the position of the image
Zoom lever	Turn to make the image larger or smaller.

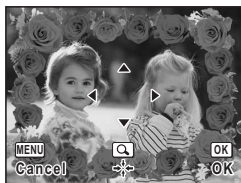

## 8 Press the OK button.

A confirmation dialog for overwriting the image appears.

When the selected image is protected, the processed image will be saved as a new image without the following confirmation dialog displayed on the screen.

## 9 Use the four-way controller (▲▼) to select [Overwrite] or [Save as].

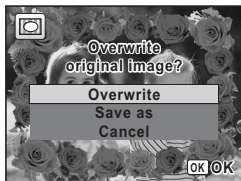

## 10 Press the OK button.

The edited image is saved with the recorded pixels of 3M (2048×1536).

## Optional Frames

The optional frames are stored in the built-in memory in the Optio P70. These optional frames are deleted if the files on the built-in memory are deleted with a computer or the built-in memory is formatted. To reload the optional frames into the built-in memory, copy the files from the CD-ROM (S-SW87) supplied with the camera.

### To Copy Frames

- 1 Remove the SD Memory Card from the camera.**  
If you leave the SD Memory Card in the camera, the frames will be copied onto the card, not into the camera's built-in memory.
- 2 Connect the camera to the computer using the provided USB cable (I-USB7).**  
Refer to "Connecting to a Computer" (p.199) for instructions on connecting the camera to a computer.
- 3 When the device detection window opens, click [Cancel].**
- 4 Insert the CD-ROM (S-SW87) into the CD-ROM drive.**
- 5 When the installer window opens, click [EXIT].**
- 6 If there is not already a "FRAME" folder in the root directory of the camera (removable disk), create the folder.**
- 7 Copy the desired files from the FRAME folder in the root directory of the CD-ROM to the FRAME folder on the camera (removable disk).**  
For information on working with files on your computer, refer to the instruction manual supplied with the computer.
- 8 Disconnect the USB cable from the computer and camera.**  
Refer to "Connecting to a Computer" (p.199) for instructions on disconnecting the cable.

- Frames can be stored both in the built-in memory and on the SD Memory Cards, but using large numbers of frames may slow down processing times.

## To Use a New Frame

The frames downloaded from the PENTAX website or other source can be used for adding a frame to pictures.



- Extract the downloaded frame and copy it to the FRAME folder in the built-in memory or the SD Memory Card.
- The FRAME folder is created when the SD Memory Card is formatted with this camera.
- For more information on downloading, refer to the PENTAX website.

## Editing Movies

You can select a frame from the recorded movie to save as a still picture or divide a movie into two.

5

**1** Enter the mode and use the four-way controller (◀▶) to choose the movie you want to edit.

**2** Press the four-way controller (▼).  
The Playback Mode Palette appears.

**3** Use the four-way controller (▲▼◀▶) to select (Movie Edit).



**4** Press the OK button.  
The movie edit selection screen appears.  
You can proceed to the following steps.



## To Save a Frame from a Movie as a Still Picture

**5** Select [Save as Still Image] on the movie edit selection screen.

**6** Press the **OK** button.

The screen appears for selecting a frame to be saved as a still picture.

**7** Use the four-way controller (**▲▼◀▶**) to choose the frame you want to save.

- ▲ Plays or pauses the movie
- ▼ Stops the movie and returns to the first frame
- ◀ Reverses the movie frame by frame
- ▶ Advances the movie frame by frame

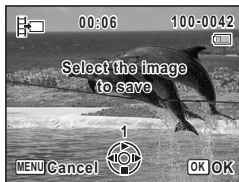

**8** Press the **OK** button.

The selected frame is saved as a still picture.

## To Divide a Movie

**5** Select [Divide Movies] on the movie edit selection screen.

**6** Press the **OK** button.

The screen for choosing the dividing position appears.

**7** Use the four-way controller (**▲▼◀▶**) to determine the dividing position.

- ▲ Plays or pauses the movie
- ▼ Stops the movie and returns to the first frame
- ◀ Reverses the movie frame by frame
- ▶ Advances the movie frame by frame



**8** Press the **OK** button.

A confirmation dialog appears.

- 9** Use the four-way controller (▲▼) to select [Divide].

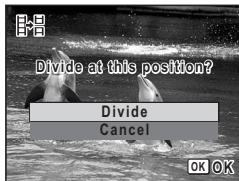

- 10** Press the OK button.

The movie is divided at the specified position, the two portions are saved as new files, and the original one is deleted.



The protected movies cannot be divided.

## Copying Images and Sound Files

5

You can copy images and sound files from the built-in memory to the SD Memory Card and vice versa. This function can only be selected when an SD Memory Card has been inserted in the camera.



Make sure that the camera is turned off before inserting or removing the SD Memory Card.

- 1** Press the four-way controller (▼) in  mode.

The Playback Mode Palette appears.

- 2** Use the four-way controller (▲▼◀▶) to select  (Image/Sound Copy).



- 3** Press the OK button.

The copying method selection screen appears.

## To Copy Files from the Built-in Memory to the SD Memory Card

All the images and sound files in the built-in memory are copied to the SD Memory Card at once. Before copying the images, make sure that there is enough space on the SD Memory Card.

- 4** Use the four-way controller (▲▼) to select [**●** → **SD**].



- 5** Press the **OK** button.

All the images and sound files are copied.

## To Copy Files from the SD Memory Card to the Built-in Memory

Selected images and sound files from the SD Memory Card are copied to the built-in memory one at a time.

- 4** Use the four-way controller (▲▼) to select [**SD** → **●**].

- 5** Press the **OK** button.

- 6** Use the four-way controller (◀▶) to select the image/sound file you want to copy.



- 7** Press the **OK** button.

The selected image/sound file is copied.



- If sound (Voice memo) has been recorded with the image, the sound file is copied with the image.
- When a file is copied from the SD Memory Card to the built-in memory, it is assigned a new file name.

# Setting the Printing Service (DPOF)

DPOF (Digital Print Order Format) is the format for storing print order data on still pictures captured with a digital camera. Once the print order data have been stored, the pictures can be printed according to the DPOF settings using a DPOF-compatible printer or photo processing lab.

You cannot store print order data for movies or sound-only files.



- If the picture already has the date and/or time imprinted on it (p.116), do not set [Date]  (On) in DPOF settings. If you select  (On), the imprinted date and/or time may overlap.
- You cannot specify DPOF settings for images registered in the "Favorites". Specify the settings for the original image.

5

## Printing Single Images

Set the following items for each image.

Copies	Choose the number of copies up to 99.
Date	Specify whether you want the date inserted on the print or not.

**1** In  mode, press the four-way controller (▼).

The Playback Mode Palette appears.

**2** Use the four-way controller (▲▼◀▶) to select  (DPOF).

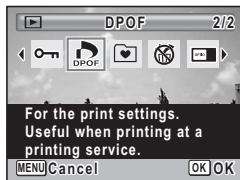

**3** Press the OK button.

The screen for selecting [Single Image] or [All Images] appears.

- 4** Use the four-way controller (▲▼) to select [Single Image].



- 5** Press the **OK** button.

The message [DPOF setting for this image] appears.

To make DPOF settings for another image, use the four-way controller (◀▶) to select another image.

If DPOF settings have already been made for an image, the previous number of copies and date setting (☑ or ☐) will be displayed.

- 6** Use the four-way controller (▲▼) to choose the number of copies.

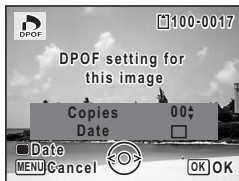

- 7** Use the **Green** button to choose whether to insert the date or not.

- (On) The date will be imprinted.
- (Off) The date will not be imprinted.

To continue setting DPOF print order data, use the four-way controller (◀▶) to choose another image and repeat Steps 6 and 7.



- 8** Press the **OK** button.

The setting is saved and the screen returns to the DPOF menu.



Depending on the printer or printing equipment at the photo processing lab, the date may not be imprinted on the pictures even if ☑ (On) is selected in the DPOF settings.



To cancel DPOF settings, set the number of copies to [00] in Step 6 and press the **OK** button.

## Printing All Images

When you choose the number of copies and whether or not to insert the date, the settings are applied to all the images stored in the camera.

**1** Select **[All Images]** in Step 4 on p.169.

**2** Press the **OK** button.

The message [DPOF setting for all images] appears.

**3** Choose the number of copies and whether to insert the date or not.

Refer to Steps 6 and 7 in “Printing Single Images” (p.169) for details of how to make the settings.



**4** Press the **OK** button.

The settings for all the images are saved and the camera returns to the DPOF setting screen.



- The number of copies specified in the DPOF settings applies to all the images. Before printing, check that the number is correct.
- Settings for single images are canceled when settings are made with [All Images].

# Printing Using PictBridge

By connecting the camera to a printer that supports PictBridge using the USB cable (I-USB7) provided, you can print images directly from the camera without using a computer. Connect the camera to the printer and select the images you want to print and the number of copies on the camera.

Caution

- It is recommended to use the optional AC adapter kit K-AC88 when the camera is connected to the printer (p.33). The printer may not work properly or the image data may be lost if the battery runs out of power while the camera is connected to the printer.
- Do not disconnect the USB cable during data transfer.
- If the image already has the date and/or time imprinted on it (p.116), do not set [Date]  (On) in PictBridge setting. If you select  (On), the imprinted date and/or time may overlap.
- Depending on the model of printer, not all the settings made on the camera (such as print settings and DPOF settings) may be valid.
- A printing error may occur if the selected number of copies exceeds 500.
- Printing the index of the images (printing multiple images on a single sheet) cannot be performed directly from the camera. Make the settings on a printer supporting index printing function or use a computer.
- You cannot use PictBridge to print images registered in the "Favorites". Print the original images.

## Changing the USB Connection Mode



Set the device to which the camera is connected with the USB cable.

Caution

Make sure to set the USB Connection mode before connecting your camera to the printer. You cannot perform the following setting if your camera is connected to the printer with the USB/AV cable.

### 1 Press the **MENU** button in mode.

The [ Setting] menu appears.

When you press the **MENU** button in  mode, press the four-way controller () once.

### 2 Use the four-way controller ( ) to select [USB Connection].

### 3 Press the four-way controller (▶).

A pull-down menu appears.

### 4 Use the four-way controller (▲▼) to select [PictBridge].

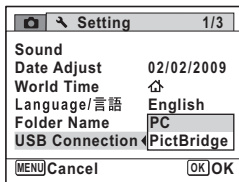

### 5 Press the OK button.

The setting is saved.



Do not connect the camera to your printer while [PC] is selected for the USB Connection mode.

5

## Connecting the Camera to the Printer

### 1 Turn off the camera.

### 2 Connect the camera to the printer using the USB cable.

### 3 Turn on the printer.

### 4 When the printer is ready to print, turn the camera on.

The printing mode selection screen appears.

Go to the following pages.

“Printing Single Images” (p.173)

“Printing All Images” (p.175)

“Printing Using the DPOF Settings”  
(p.176)

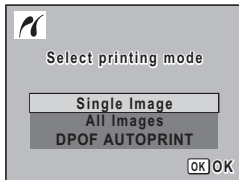

## Printing Single Images

- 1 In the printing mode selection screen, use the four-way controller (▲▼) to select [Single Image].**

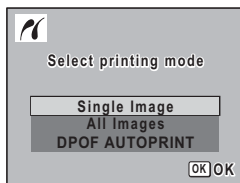

- 2 Press the OK button.**  
The setting screen appears.

- 3 Use the four-way controller (◀▶) to choose the image to print.**

- 4 Use the four-way controller (▲▼) to choose the number of copies.**  
You can print up to 99 copies.



- 5 Use the Green button to choose whether to insert the date or not.**

- (On) The date will be imprinted.
- (Off) The date will not be imprinted.

- 6 Press the OK button.**

A confirmation dialog appears.  
To print the pictures according to the print settings on the printer, press the **OK** button.

To change the print settings, go to Step 7.

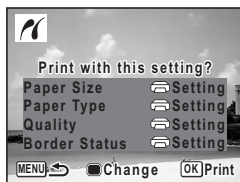

- 7 Press the Green button.**

The screen for changing the print settings appears.

## 8 Select [Paper Size] and press the four-way controller (►).

The [Paper Size] screen appears.

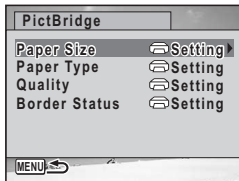

## 9 Use the four-way controller (▲▼◀▶) to choose the paper size.

You can only choose the size that is supported by your printer.

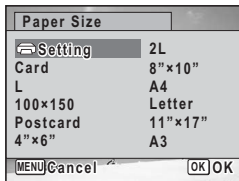

## 10 Press the OK button.

The [Paper Size] setting is saved, and the screen returns to the print settings screen.

## 11 Use the four-way controller (▲▼) to select [Paper Type] and press the four-way controller (►).

A pull-down menu appears.

## 12 Use the four-way controller (▲▼) to select the paper type and press the OK button.

The [Paper Type] setting is saved, and the screen returns to the print settings screen. Set [Quality] and [Border Status] in the same way as in Steps 11 and 12.

If you select [Setting] for each print setting, images are printed according to the settings made on the printer.

Paper Type with more ★ supports higher quality paper.

Quality with more ★ indicates higher print quality.

A confirmation dialog appears after each item has been set.

## 13 Press the MENU button.

The screen returns to the confirmation dialog.

## 14 Press the OK button.

The image is printed according to the settings.

Press the **MENU** button to cancel printing.



- The self-timer lamp lights while the camera is communicating with the printer, and blinks while the card is being accessed and during printing. Do not disconnect the USB cable while the self-timer lamp lights or blinks.
- The [Paper Size], [Paper Type], [Quality] and [Border Status] settings are reset to the defaults when the camera is turned off.

## Printing All Images

- 1 In the printing mode selection screen, use the four-way controller (▲▼) to select [All Images].**

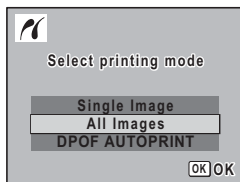

- 2 Press the OK button.**

The setting screen appears.

- 3 Choose the number of copies and whether to insert the date or not.**

The number of copies and date setting that you choose apply to all the images.

Refer to Steps 4 and 5 in “Printing Single Images” (p.173) for details of how to make the settings.

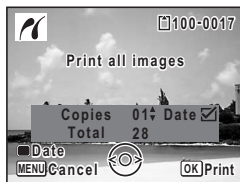

- 4 Press the OK button.**

A confirmation dialog appears.

Refer to Steps 7 to 13 of “Printing Single Images” (p.173) for details of changing print settings.

- 5 Press the OK button on the print settings confirmation screen.**

All the images are printed according to the settings.

Press the **MENU** button to cancel printing.

## Printing Using the DPOF Settings

**1** In the printing mode selection screen, use the four-way controller (▲▼) to select [DPOF AUTOPRINT].

**2** Press the **OK** button.

The DPOF settings you have made appear.

Use the four-way controller (◀▶) to check the number of copies for each picture, whether to insert the date or not, and the total number of copies. Refer to p.168 for instructions on how to make the DPOF settings.

**3** Press the **OK** button.

A confirmation dialog appears.

Refer to Steps 7 to 13 of “Printing Single Images” (p.173) for details of changing print settings.

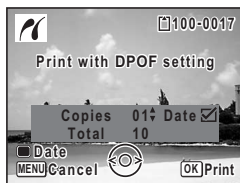

**4** Press the **OK** button.

The images are printed according to the settings.

Press the **MENU** button to cancel printing.

## Disconnecting the Cable from the Printer

Disconnect the USB cable from the camera and printer when you have finished printing.

**1** Turn off the camera and printer.

**2** Disconnect the USB cable from the camera and printer.

# **6 Recording and Playing Back Sound**

---

<b>Recording Sound (Voice Recording)</b> .....	<b>178</b>
<b>Adding a Voice Memo to Images</b> .....	<b>181</b>

# Recording Sound (Voice Recording)

You can record sound with the camera. The microphone is located on the front of the camera. When recording sound, aim the camera at the sound source to obtain the best sound quality.

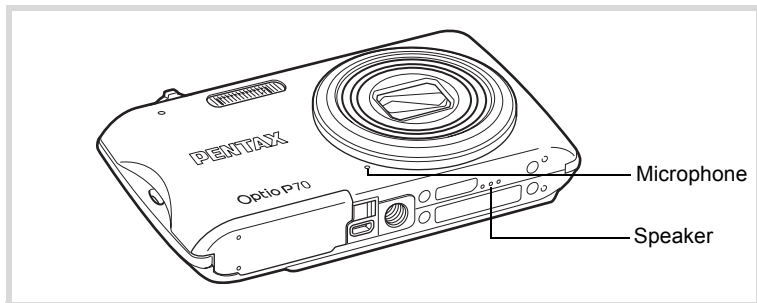

## Setting the Voice Recording Function

6

To use the Voice Recording function, assign it to the Green button first.

### 1 Press the **MENU** button in **📷** mode.

The [📷 Rec. Mode] menu appears.

### 2 Use the four-way controller (▲▼) to select [Green Button].

### 3 Press the four-way controller (▶).

A pull-down menu appears.

### 4 Use the four-way controller (▲▼) to select [Voice Recording] and press the **OK** button.

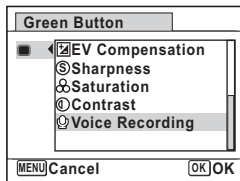

### 5 Press the **MENU** button.

The Voice Recording function is assigned to the Green button.

## Recording Sound

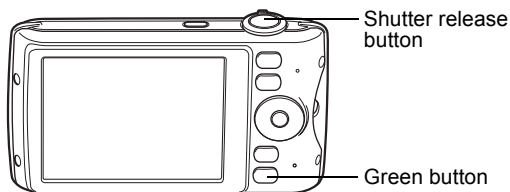

### 1 Press the Green button in mode.

The camera enters the Voice Recording mode. The remaining recordable time and the recording time of the current file appear on the display.

- 1 Recording time
- 2 Remaining recordable time

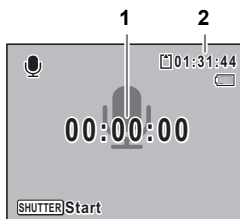

### 2 Press the shutter release button fully.

Recording starts. The self-timer lamp blinks during recording.

You can record sounds continuously for up to 24 hours.

When the Green button is pressed during recording, an index is added to the current sound file.



### 3 Press the shutter release button fully.

Recording stops.





- If you press and hold down the shutter release button for more than one second in Step 2, recording continues until you take your finger off the button. This is useful for making short sound recordings.
- The sound is saved in WAVE monaural files.

## Playing Back Sound

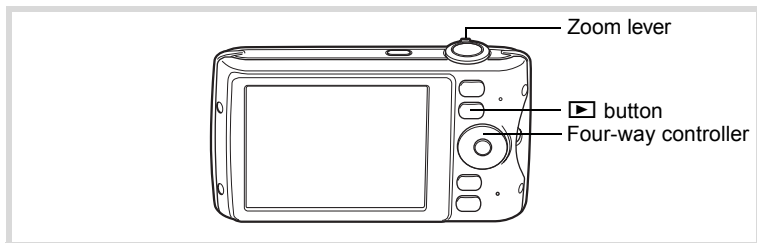
You can play back the sound files you made in Voice Recording.



- 1 Press the  button.**
- 2 Use the four-way controller ( ) to choose the sound file to play back.**



- 3 Press the four-way controller ().**

Playback starts.

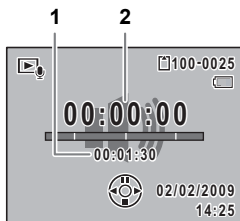

- 1 Total file recording time
- 2 Playback time





**The following operations can be performed during playback.**

- Four-way controller () Pauses playback
- Zoom lever to the right () Increases the volume
- Zoom lever to the left () Reduces the volume



If there are no recorded indexes:

- Four-way controller () Fast-reverses playback
- Four-way controller () Fast-forwards playback

If there are recorded indexes:

- Four-way controller () Plays back starting from the previous index
- Four-way controller () Plays back starting from the next index

**The following operations can be performed while playback is paused.**

- Four-way controller () Resumes playback
- Four-way controller () Rewinds approx. 5 seconds
- Four-way controller () Advances approx. 5 seconds

- 4 Press the four-way controller ().**

Playback stops.

# Adding a Voice Memo to Images

You can add a voice memo to your still pictures.

## Recording a Voice Memo

**1** Enter  mode and use the four-way controller (◀▶) to choose the still picture to which you want to add a voice memo.

**2** Press the four-way controller (▼).  
The Playback Mode Palette appears.

**3** Use the four-way controller (▲▼◀▶) to select  (Voice Memo).



**4** Press the OK button.  
Recording starts. You can record a voice memo continuously for up to 24 hours.





**5** Press the OK button.  
Recording stops.

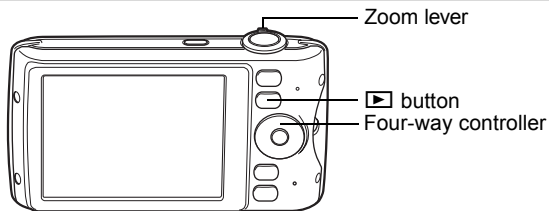

- A voice memo cannot be added to the image that already has a voice memo. Delete the old voice memo (p.143) and record a new one.
- A voice memo cannot be added to protected images (p.148).

## Playing Back a Voice Memo



- 1 Enter  mode and use the four-way controller (◀▶) to choose the still picture with the voice memo that you want to play back.**

 appears on images with voice memos in single-image display.

- 2 Press the four-way controller (▲).**

Playback starts.



**The following operations can be performed during playback.**

- Zoom lever to the right (▲) Increases the volume
- Zoom lever to the left (▼) Reduces the volume

- 3 Press the four-way controller (▼).**

Playback stops.

To Delete a Sound File  p.143

# 7 Settings

---

Camera Settings .....	184
-----------------------	-----

## Formatting an SD Memory Card



Formatting will delete all the data on the SD Memory Card. Be sure to use this camera to format (initialize) an SD Memory Card that is unused or has been used on other cameras or digital devices.



- Do not remove the SD Memory Card during formatting as this may damage the card and render it unusable.
- Formatting will delete protected images and any data recorded on the card with a computer or camera other than this camera.
- SD Memory Cards formatted on a computer or device other than the camera cannot be used. Be sure to format the card with the camera.
- The built-in memory cannot be formatted except when an error occurs.

### 1 Press the **MENU** button in mode.

The [ Setting] menu appears.

When you press the **MENU** button in  mode, press the four-way controller () once.

### 2 Use the four-way controller ( ) to select [Format].

### 3 Press the four-way controller ()

The [Format] screen appears.

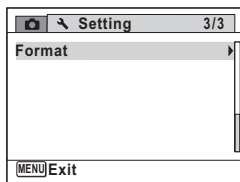

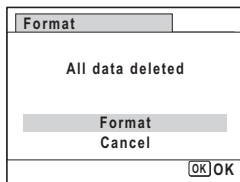

### 4 Use the four-way controller ( ) to select [Format].



## 5 Press the OK button.

Formatting starts.



When formatting is completed, the camera returns to  mode or  mode.

## Changing the Sound Settings

You can adjust the volume of operation sounds and change the type of sound.

### 1 Press the MENU button in mode.

The [ Setting] menu appears.

When you press the **MENU** button in  mode, press the four-way controller () once.

### 2 Use the four-way controller ( ) to select [Sound].

### 3 Press the four-way controller () .

The [Sound] screen appears.

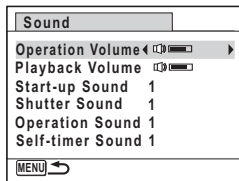

## To Change the Operation Volume/Playback Volume

### 4 Use the four-way controller ( ) to select [Operation Volume].

### 5 Use the four-way controller ( ) to adjust the volume.

Set the volume to 0 to mute the start-up sound, shutter sound, operation sound, and self-timer sound.

### 6 Change [Playback Volume] in the same way as in Steps 4 and 5.

## To Change the Sound Type

- 4 Use the four-way controller (▲▼) to select [Start-up Sound].**
- 5 Press the four-way controller (▶).**  
A pull-down menu appears.
- 6 Use the four-way controller (▲▼) to select the sound type.**  
Choose from [1], [2], [3] or [Off].
- 7 Press the OK button.**
- 8 Set [Shutter Sound], [Operation Sound] and [Self-timer Sound] in the same way as in Steps 4 to 7.**
- 9 Press the MENU button.**  
The screen returns to the [ Setting] menu.

## Changing the Date and Time

You can change the initial date and time settings (p.45). You can also set the style in which the date appears on the camera.

- 1 Press the MENU button in mode.**  
The [ Setting] menu appears.  
When you press the **MENU** button in mode, press the four-way controller (▶) once.
- 2 Use the four-way controller (▲▼) to select [Date Adjust].**
- 3 Press the four-way controller (▶).**  
The [Date Adjust] screen appears.

**4 Press the four-way controller (▶).**

The frame moves to [mm/dd/yy].  
Depending on the initial setting or previous setting, [dd/mm/yy] or [yy/mm/dd] may be displayed.

Date Adjust	
Date Style	▶mm/dd/yy 24h
Date	01/01/2009
Time	00:00
[MENU]Cancel [OK]OK	

**5 Use the four-way controller (▲▼) to choose the date and time display style.**

Choose from [mm/dd/yy], [dd/mm/yy] or [yy/mm/dd].

Date Adjust	
Date Style	◀mm/dd/yy 24h
Date	01/01/2009
Time	00:00
[MENU]Cancel [OK]OK	

**6 Press the four-way controller (▶).**

The frame moves to [24h].

**7 Use the four-way controller (▲▼) to select [24h] (24-hour display) or [12h] (12-hour display).**

Date Adjust	
Date Style	◀mm/dd/yy 24h
Date	01/01/2009
Time	00:00
[MENU]Cancel [OK]OK	

**8 Press the four-way controller (▶).**

The frame returns to [Date Style].

**9 Press the four-way controller (▼).**

The frame moves to [Date].

## 10 Press the four-way controller (▶).

The frame moves to one of the following items depending on the date style set in Step 5.

Month for [mm/dd/yy]

Day for [dd/mm/yy]

Year for [yy/mm/dd]

The following operations and screens use [mm/dd/yy] as an example. The operations are the same even if another date style has been selected.

Date Adjust	
Date Style	mm/dd/yy 24h
Date	▶01/01/2009
Time	00:00
MENU Cancel <span style="float:right">OK OK</span>	

## 11 Use the four-way controller (▲▼) to change the month.

Date Adjust	
Date Style	mm/dd/yy 24h
Date	◀ 01/01/2009 ▲
Time	00:00
MENU Cancel <span style="float:right">OK OK</span>	

## 12 Press the four-way controller (▶).

The frame moves to the day field. Use the four-way controller (▲▼) to change the day. After changing the day, change the year in the same manner.

## 13 Change the time in the same way as in Steps 8 to 12.

If you selected [12h] in Step 7, the setting switches between am and pm corresponding to the time.

## 14 Press the OK button.



## 15 Press the OK button.

The date and time settings are saved.



When you press the **OK** button in Step 15, the camera clock is reset to 00 seconds. To set the exact time, press the **OK** button when the time signal (on the TV, radio, etc.) reaches 00 seconds.



## Setting the World Time

The date and time selected in “Setting the Date and Time” (p.45) and “Changing the Date and Time” (p.186) serve as the  (Hometown) date and time. By using the world time function, you can display the time in a city other than the Hometown ( Destination). This is useful when taking pictures in a different time zone.

### To Set the Destination

#### 1 Press the MENU button in mode.

The  Setting] menu appears.

When you press the MENU button in  mode, press the four-way controller () once.

#### 2 Use the four-way controller ( ) to select [World Time].

#### 3 Press the four-way controller () .

The [World Time] screen appears.

#### 4 Use the four-way controller ( ) to select (Destination).

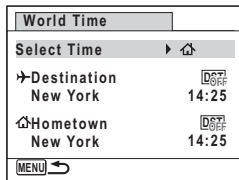

#### 5 Press the four-way controller () .

The [Destination] screen appears. The city that is currently selected blinks on the map.

#### 6 Use the four-way controller ( ) to change the Destination city.

The current time, location and time difference of the selected city appear.

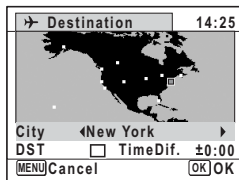

- 7** Use the four-way controller (▲▼) to select [DST].
- 8** Use the four-way controller (◀▶) to select  (On) or  (Off).  
Select  (On) if the Destination city uses daylight saving time.
- 9** Press the OK button.  
The [World Time] setting is saved.
- 10** Press the MENU button twice.  
The camera returns to capture status with the current setting.



Select (Hometown) in Step 4 to set the city and DST setting for the Hometown city.

## To Display the Time of the Destination (Select Time)

- 1** Press the MENU button in mode.  
The [ Setting] menu appears.  
When you press the MENU button in mode, press the four-way controller (▶) once.
- 2** Use the four-way controller (▲▼) to select [World Time].
- 3** Press the four-way controller (▶).  
The [World Time] screen appears.
- 4** Use the four-way controller (▲▼) to select [Select Time].

World Time	
Select Time	▶
→ Destination	<input type="checkbox"/> DST
London	20:25
Hometown	<input type="checkbox"/> DST
New York	14:25
MENU	

- 5** Press the four-way controller (▶).  
A pull-down menu appears.

## 6 Use the four-way controller (▲▼) to select ➔ (Destination) or ⏏ (Hometown).

- ➔ Displays the time of the Destination city
- ⏏ Displays the time of the Hometown city

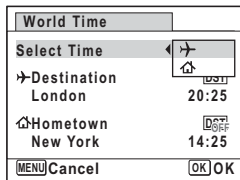

## 7 Press the OK button.

The setting is saved.

## 8 Press the MENU button twice.

The camera returns to 📷 mode or ▶ mode.

When ➔ (Destination) is selected in Step 6, the ➔ icon appears on the display to indicate that the destination date and time are displayed in 📷 mode.



## Changing the Display Language

You can change the language in which the menus, error messages, etc. are displayed.

The camera supports the following 20 languages: English, French, German, Spanish, Portuguese, Italian, Dutch, Japanese, Danish, Swedish, Finnish, Polish, Czech, Hungarian, Turkish, Greek, Russian, Thai, Korean and Chinese (traditional and simplified).

## 1 Press the MENU button in ▶ mode.

The [⏏ Setting] menu appears.

When you press the **MENU** button in 📷 mode, press the four-way controller (▶) once.

## 2 Use the four-way controller (▲▼) to select [Language/言語].

### 3 Press the four-way controller (▶).

The [Language/言語] screen appears.

### 4 Use the four-way controller (▲▼◀▶) to select the language.

Language/言語		
English	日本語	Türkçe
Français	Dansk	Ελληνικά
Deutsch	Svenska	Русский
Español	Suomi	ไทย
Português	Polski	한국어
Italiano	Čeština	中文繁體
Nederlands	Magyar	中文简体
MENU/Cancel		OK/OK

### 5 Press the OK button.

The menus and messages are displayed in the selected language.

## Changing the Naming Rule of the Folder

You can change the naming rule of the folder for storing images. When the naming rule is set to the date, pictures are saved in separate folders by the date they were taken.

Date	xxx_mmdd (3-digit folder number_month day) * xxx_ddmm (3-digit folder number_day month) when the date style is set to [dd/mm/yy]
Standard	xxxPENTX (where xxx is the 3-digit folder number)

Taken with the folder name setting [Standard].  
(e.g. September 25)

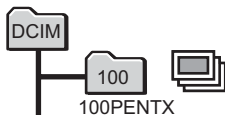

Taken with the folder name setting [Date].  
(e.g. September 25)

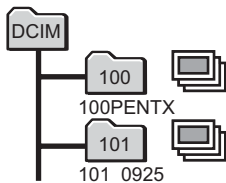

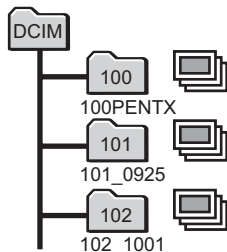

Next time, taken with the folder name setting [Date] again.  
(e.g. October 1)



- Up to 999 folders can be created.
- Up to 9999 images or sounds can be saved in a folder.

## 1 Press the MENU button in mode.

The [ Setting] menu appears.

When you press the MENU button in  mode, press the four-way controller () once.

## 2 Use the four-way controller ( ) to select [Folder Name].

## 3 Press the four-way controller () .

A pull-down menu appears.

## 4 Use the four-way controller ( ) to select [Standard] or [Date].

## 5 Press the OK button.



The setting is saved.

## Changing the Video Output Format

When you connect the camera to AV equipment, choose the appropriate video output format (NTSC or PAL) for taking and playing back images.

## 1 Press the MENU button in mode.

The [ Setting] menu appears.

When you press the MENU button in  mode, press the four-way controller () once.

## 2 Use the four-way controller ( ) to select [Video Out].

## 3 Press the four-way controller () .

A pull-down menu appears.

## 4 Use the four-way controller ( ) to select a video output format.

Choose the video output format to match the output format of the AV equipment.

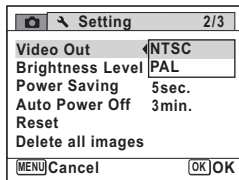

## 5 Press the OK button.

The setting is saved.



Depending on the country or region, images and sound files may fail to be played back if the video output format is set different from the one in use there. If this happens, change the video output format setting.

Connecting the Camera to AV Equipment p.151  
Video output format of each city p.234

## Adjusting the Brightness of the Display

You can adjust the brightness of the display.

### 1 Press the MENU button in mode.

The [ Setting] menu appears.

When you press the **MENU** button in mode, press the four-way controller () once.

### 2 Use the four-way controller ( ) to select [Brightness Level].

### 3 Use the four-way controller ( ) to adjust the brightness.

- Dark
- Normal
- Bright

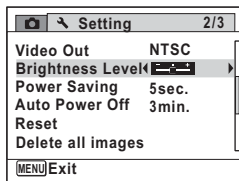

### 4 Press the MENU button.



The camera returns to mode or mode.  
The display appears with the set brightness.

## Using the Power Saving Function

You can save battery power by setting the display to dim automatically when no operation is performed for a fixed time. After the power saving function has been activated, the display returns to the ordinary brightness by pressing any of the buttons.

### 1 Press the **MENU** button in mode.

The [ Setting] menu appears.

When you press the **MENU** button in  mode, press the four-way controller () once.

### 2 Use the four-way controller ( ) to select [Power Saving].

### 3 Press the four-way controller ().

A pull-down menu appears.

### 4 Use the four-way controller ( ) to select the time until the camera enters power saving mode.

Choose from [2min.], [1min.], [30sec.], [15sec.], [5sec.] or [Off].

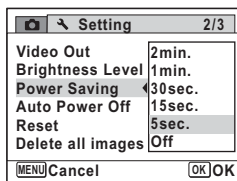

### 5 Press the **OK** button.

The setting is saved.





- Power Saving does not function in the following situations:
  - while taking pictures in Continuous Shooting mode
  - in the playback mode
  - while recording a movie
  - while the camera is connected to a computer or printer
  - when using the AC adapter
  - while a menu is being displayed
- When no operation is performed after the camera is turned on, Power Saving is activated only after 15 seconds elapse even if [5sec.] is set.

## Setting Auto Power Off

You can set the camera to turn off automatically when no operation is performed for a fixed time.

### 1 Press the **MENU** button in mode.

The [ Setting] menu appears.

When you press the **MENU** button in  mode, press the four-way controller () once.

### 2 Use the four-way controller ( ) to select [**Auto Power Off**].

### 3 Press the four-way controller ().

A pull-down menu appears.

### 4 Use the four-way controller ( ) to select the time until the camera turns off automatically.

Choose from [5min.], [3min.] or [Off].

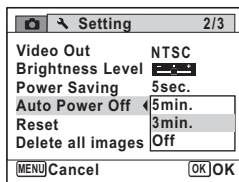

### 5 Press the **OK** button.

The setting is saved.

7

Settings



- Auto Power Off does not function in the following situations:
  - while recording sound in Voice Recording mode
  - while taking pictures in Continuous Shooting mode
  - while recording a movie
  - during a slideshow or movie/sound playback
  - while the camera is connected to a computer or printer
- In Vertical Snap mode, the camera turns off after 5 minutes regardless of the Auto Power Off setting.

## Changing the Start-up Screen

You can choose the start-up screen displayed when the camera is turned on.

You can choose any of the following images as the start-up screen:

- The Guide Display Start-up Screen showing a guide to the shooting modes and buttons
- One of the 3 Optio logos
- One of your own images (compatible images only)

### 1 In mode, press the four-way controller (▼).

The Playback Mode Palette appears.

### 2 Use the four-way controller (▲▼◀▶) to select (Start-up Screen).



### 3 Press the OK button.

The image selection screen appears.

### 4 Use the four-way controller (◀▶) to choose the image for the start-up screen.

Only images suitable for the start-up screen are displayed. You can also choose one of the 3 Optio logos or the Guide Display Start-up Screen already stored in the camera.



### 5 Press the OK button.

The setting is saved.





- Once the start-up screen has been set, it will not be deleted even if the original image is deleted or the SD Memory Card is formatted.
- Select [Off] to hide the start-up screen.
- The start-up screen is not displayed when you turn the camera on in the playback mode.

## Resetting to Default Settings (Reset)

You can reset the camera settings to their defaults. Refer to “Default Settings” (p.229) for the reset settings.

### 1 Press the **MENU** button in mode.

The [ Setting] menu appears.

When you press the **MENU** button in  mode, press the four-way controller () once.

### 2 Use the four-way controller ( ) to select [Reset].

### 3 Press the four-way controller (.

The [Reset] screen appears.

### 4 Use the four-way controller ( ) to select [Reset].

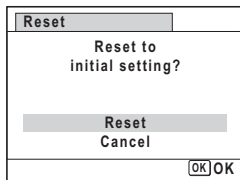

### 5 Press the **OK** button.

The settings return to the defaults.

7



The following settings are not affected by resetting:

- Date Adjust
- World Time
- Language/言語
- Video Out

# **8 Connecting to a Computer**

---

<b>Setting Up Your Computer .....</b>	<b>200</b>
<b>Connecting to a Windows PC .....</b>	<b>208</b>
<b>Connecting to a Macintosh .....</b>	<b>216</b>

# Setting Up Your Computer

By installing the software included on the provided CD-ROM on your computer and connecting the camera to your computer with the USB cable, you can transfer images and movies captured with your camera to the computer and then display and manage them. This section explains how to install the provided software and the other necessary preparations for enjoying the captured pictures and movies on your computer.

## Provided Software

The following software is included in the provided CD-ROM (S-SW87).

### Windows

- Image viewing/managing/editing software “ACDSee for PENTAX 3.0” (Nine languages: English, French, German, Spanish, Italian, Russian, Chinese [traditional and simplified], Korean, Japanese)

### Macintosh

- Image viewing/managing software “ACDSee 2 for Mac” (Six languages: English, French, German, Spanish, Italian, Japanese)



It is recommended to use the optional AC adapter kit K-AC88 when the camera is connected to the computer (p.33). If the battery runs out of power while images are being transmitted to the computer, the image data may be lost or damaged.

## System Requirements

The following system requirements must be met for you to fully enjoy the images and movies captured with the camera on your computer.

### Windows

OS	Windows 2000, Windows XP or Windows Vista <ul style="list-style-type: none"><li>The OS must be preinstalled and updated to the latest version.</li></ul>
CPU	Pentium III or higher
Memory	256 MB minimum (512 MB or more recommended)
Hard Disk Space	100 MB minimum (1 GB or more recommended)
Others	CD-ROM drive USB port as standard equipment Internet Explorer 5.0 or later DirectX 9.0 or later and Windows Media Player 9.0 or later (for playing movies)

- \* Operation is not guaranteed on all computers meeting the system requirements.
- \* The system requirements describe the minimum environment for playing and editing movies.



Windows 95, Windows 98, Windows 98SE, Windows Me and Windows NT are not supported.



The versions of Internet Explorer, Windows Media Player and DirectX required for using "ACDSee for PENTAX 3.0" are not included in the provided CD-ROM (S-SW87). Visit the following sites to download the necessary items and install/update them on your computer.

- **Internet Explorer**

<http://www.microsoft.com/windows/products/winfamily/ie/default.aspx>

- **Windows Media Player**

<http://www.microsoft.com/windows/products/winfamily/mediaplayer/default.aspx>

- **DirectX**

<http://www.microsoft.com/windows/directx/default.aspx>

## Macintosh

OS	Mac OS X (Ver.10.1.2 - 10.5) <ul style="list-style-type: none"><li>• The OS must be preinstalled and updated to the latest version.</li><li>• System requirements for using the provided software "ACDSee 2 for Mac": Mac OS X (Ver. 10.3 - 10.5)</li></ul>
CPU	Power Macintosh 233 MHz or higher
Memory	8 MB minimum
Hard Disk Space	6 MB minimum
Others	CD-ROM drive USB port as standard equipment QuickTime 4.0 or later

- \* Operation is not guaranteed on all computers meeting the system requirements.

## Installing the Software

### Windows

Install the image viewing/managing/editing software (ACDSee for PENTAX 3.0).



- Make sure your Windows PC meets the system requirements before installing the software.
- When multiple accounts have been set up in Windows 2000, Windows XP or Windows Vista, log on with an account that has administrative rights before installing the software.

8

---

**1 Turn your Windows PC on.**

---

**2 Insert the provided CD-ROM into the CD-ROM drive.**

The language selection screen appears.

### If you are using Windows Vista

When the [AutoPlay] screen appears, display the language selection screen following the steps below.

- 1) Click [Run setup.exe].
- 2) Click [Allow].

### If the language selection screen does not appear

Display the language selection screen following the steps below.

- 1) Double-click [My Computer] on the desktop.
- 2) Double-click the [CD-ROM drive (S-SW87)] icon.
- 3) Double-click the [Setup.exe] icon.

## 3 Choose a language from the displayed screen.

The “ACDSee for PENTAX 3.0” installation screen appears.



## 4 Click [Install].

The setup screen appears. Follow the on-screen guidance to input registration information and install the software.



- 5** Click **[Finish]**.  
“ACDSee for PENTAX 3.0” installation is complete.

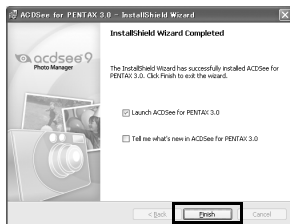

- 6** Click **[Exit]** on the installation screen.  
The window is closed.

- 7** **Reboot your Windows PC.**  
Go to “Product Registration on the Internet” (p.206).

## Macintosh

Install the image viewing/managing software (ACDSee 2 for Mac).

- 1** Turn your Macintosh on.
- 2** Insert the provided CD-ROM into the CD-ROM drive.
- 3** Double-click the CD-ROM (S-SW87) icon.
- 4** Double-click the **[ACDSee Install]** icon.

The language selection screen appears.

When the [Master Installer] icon appears, double-click it to display the language selection screen.

## 5 Choose a language from the displayed screen.

The “ACDSee 2 for Mac” installer screen appears.



## 6 Click [Install].

The setup screen appears. Follow the on-screen guidance to input registration information and install the software.



## 7 When the screen shown on the right appears, click [Yes].

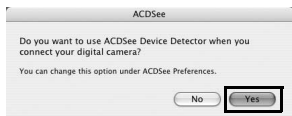

## 8 Click [Close].

“ACDSee 2 for Mac” installation is complete.



## 9 Click [Exit] on the installation screen.

The window is closed.

## Product Registration on the Internet

In order to better serve you, we request that you complete the product registration.

If your computer is connected to the Internet, please click [Product Registration] on the setup screen after the language selection screen is displayed. The world map screen shown on the right for Internet Product Registration is displayed. Click the displayed country or region and then follow the instructions to register your product.

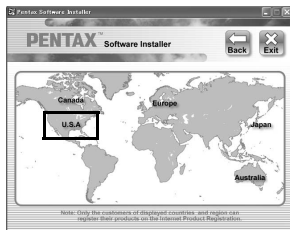

Only customers in countries and regions displayed on the software installation screen can register their products on the Internet Product Registration.

## Setting the USB Connection Mode

Set the device to which the camera is connected with the USB cable.







Make sure to set the USB Connection mode before connecting your camera to the computer. You cannot perform the following setting if the camera is connected to your computer with the USB cable.

8

- 1 Turn your camera on.**
- 2 Press the MENU button in  mode.**

The [ Setting] menu appears.

When you press the **MENU** button in  mode, press the four-way controller () once.
- 3 Use the four-way controller ( ) to select [USB Connection].**

#### 4 Press the four-way controller (▶).

A pull-down menu appears.

#### 5 Use the four-way controller (▲▼) to select [PC].

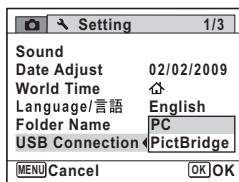

#### 6 Press the OK button.

The setting is saved.



Do not connect the camera to your computer while [PictBridge] is selected for the USB Connection mode.

Go to the following pages depending on your computer.

Connecting to a Windows PC (p.208)

Connecting to a Macintosh (p.216)

# Connecting to a Windows PC

## Connecting the Camera and Windows PC

Connect your camera to the Windows PC using the provided USB cable (I-USB7).

- 1 Turn your Windows PC on.**
- 2 Turn your camera off.**
- 3 Connect your camera to the Windows PC using the USB cable.**

Connect the terminal of the AV cable with ⇐ pointing toward the ◀ on the PC/AV terminal on the bottom of the camera.

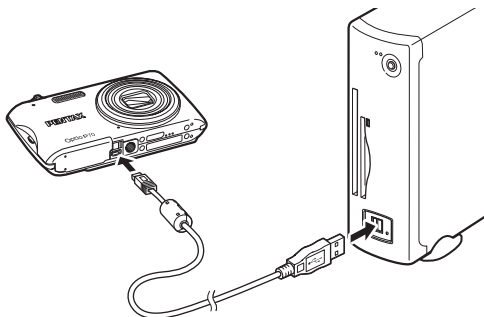

- 4 Turn your camera on.**

The “Device Detector” screen appears.  
If the “Device Detector” screen does not appear, follow the steps in “When the “Device Detector” screen does not appear” (p.210).



The self-timer lamp blinks while the camera is connected to a Windows PC.

## Transferring Images

Transfer the images captured with the camera to your Windows PC.



If there is no SD Memory Card in the camera, the images stored in the built-in memory will be transferred to your Windows PC.

- 5** Confirm that [Acquire images from the device with ACDSee] is checked and click [OK].



- 6** Click [Next].



- 7** Select an image to copy and click [Next].

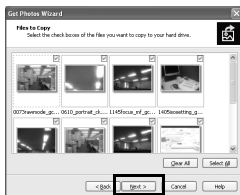

- 8** Specify [File names] and [Destination folder], and click [Next].

The images are copied to your Windows PC.

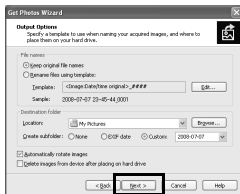

**9****Click [Finish].**

The “ACDSee for PENTAX 3.0” starts.



When the “Device Detector” screen does not appear

**5**

Double-click the [ACDSee for PENTAX 3.0] icon on the desktop.

**6**

Click [My Computer].

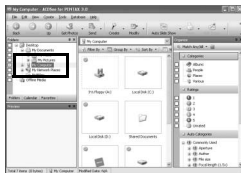
**7**

Double-click [Removable Disk].

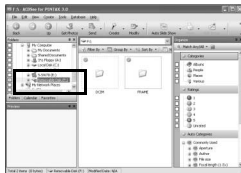
**8**

If the SD Memory Card has a volume label, the volume label name appears instead of [Removable Disk]. A new unformatted SD Memory Card may show the manufacturer name or model number.

## 8 Double-click the [DCIM] folder.

Images are stored in folders named by the shooting date (“XXX\_0202” for February 2. “XXX” is a three-digit number.).

If [Standard] is selected for [Folder Name] in the [↖ Setting] menu, a folder named “XXXPENTX” (XXX is a three-digit folder number) is displayed and images are stored here.

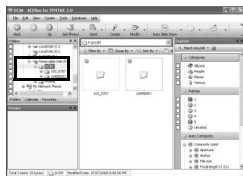

## 9 Select the folders you want to copy to the Windows PC.

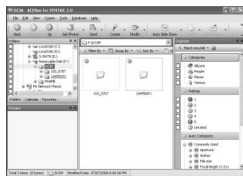

## 10 Select [Copy To Folder...] from the [Edit] menu.

The “Copy Files” screen appears.

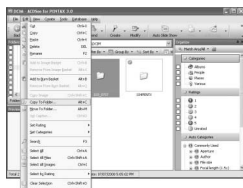

## 11 Specify the destination folder and click [OK].

The images are copied to your Windows PC.

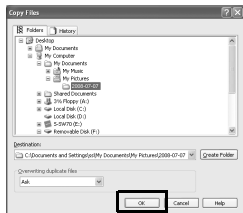

# Disconnecting the Camera from Your Windows PC

- 1 Double-click the  [Safely Remove Hardware] icon in the task bar.



The “Safely Remove Hardware” screen appears.

- 2 Select [USB Mass Storage Device] and click [Stop].

The “Stop a Hardware device” screen appears.



- 3 Select [USB Mass Storage Device] and click [OK].

A message appears indicating that the hardware can be safely removed.

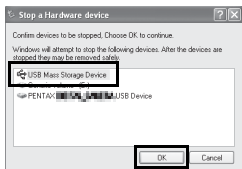

- 4 Click [OK].

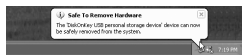

- 5 Disconnect the USB cable from your Windows PC and the camera.



- If the camera (removable disk) is being used by an application such as “ACDSee for PENTAX 3.0”, the camera cannot be disconnected until the application is closed.
- The camera will automatically switch to the playback mode when the USB cable is disconnected from your Windows PC or the camera.

## Starting “ACDSee for PENTAX 3.0”

“ACDSee for PENTAX 3.0” lets you view, edit, manage, search for, share, and print images.

### 1 Double-click the [ACDSee for PENTAX 3.0] icon on the desktop.

ACDSee starts and the main browser window appears.

## ACDSee Browser Interface

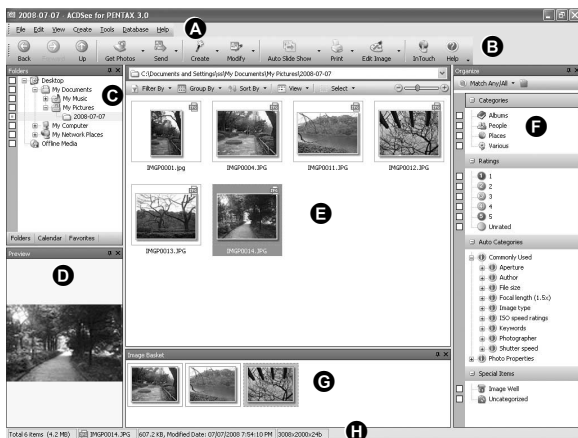

\* The screen shown is an example with the default settings.

### A Menu bar

Provides access to the various menu commands.

### B Toolbar

Provides quick access to frequently used tasks and functions.

### C Folders pane

Displays the configuration of folders in your computer. When you browse a folder, the contents of the folder appear in the File List pane.

## D Preview pane

Displays a preview of the image or media file currently selected in the File List pane. You can change the size of the preview image or play back the media file.

## E File List pane

Displays the contents of the selected folder or the results of the most recent search (the file or folder that matches the search item). It is the only pane that always appears in the browser and it cannot be hidden or closed.

## F Category pane

Displays a list of categories and priorities. By dragging and dropping files from the File List pane to here, you can set category and priority for files.

## G Image Basket pane

Displays files selected in the File List pane. By choosing images and files and putting them in the Image Basket pane, you can use the editing and creating functions on images from different folders and categories.

## H Status bar

Displays information and properties for the selected file.

# Viewing Images

- 1 Select and click the folder containing the image you want to view in the Folders pane of the ACDSee browser.**

Images are displayed in the File List pane.

- 2 Select and double-click the image you want to view in the File List pane.**

The selected image is displayed with the viewer.

With the viewer, you can enlarge/ reduce the display size of the image or edit the image. You can also play back movies or sound files.

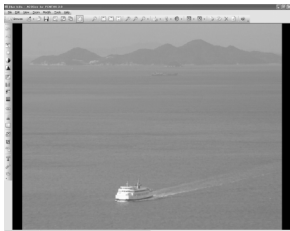



# Connecting to a Macintosh

## Connecting the Camera and Macintosh

Connect your camera to the Macintosh using the provided USB cable (I-USB7).

- 1 Turn your Macintosh on.**
- 2 Turn your camera off.**
- 3 Connect your camera to the Macintosh using the USB cable.**

Connect the terminal of the AV cable with ⇐ pointing toward the ◀ on the PC/AV terminal on the bottom of the camera.

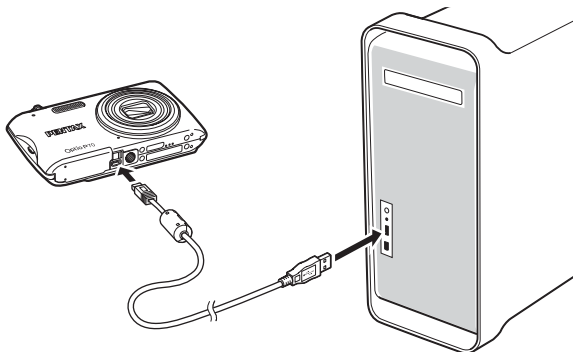

- 4 Turn your camera on.**

The camera is recognized as [NO\_NAME] on the desktop.



- If the SD Memory Card has a volume label, the volume label name appears instead of [NO\_NAME]. A new unformatted SD Memory Card may show the manufacturer name or model number.
- The self-timer lamp blinks while the camera is connected to a Macintosh.

## Transferring Images

Transfer the images captured with the camera to your Macintosh.



If there is no SD Memory Card in the camera, the images stored in the built-in memory will be transferred to your Macintosh.

**5**

**Specify a save location, make sure that [Launch ACDSee] is checked, and click [Download].**

After images are copied to your Macintosh, the “ACDSee 2 for Mac” starts.

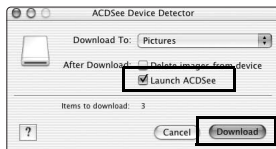

When [Delete images from device] is checked, images are deleted from the camera after transfer is complete.

## Disconnecting the Camera from Your Macintosh

**1**

**Drag [NO\_NAME] on the desktop to the trash.**

If the SD Memory Card has a volume label, drag the icon of that name to the trash.

**2**

**Disconnect the USB cable from your Macintosh and the camera.**



- If the camera (removable disk) is being used by an application such as “ACDSee 2 for Mac”, the camera cannot be disconnected until the application is closed.
- The camera will automatically switch to the playback mode when the USB cable is disconnected from your Macintosh or the camera.

## Starting “ACDSee 2 for Mac”

“ACDSee 2 for Mac” lets you display and manage images.

**1** Double-click the [ACDSee] folder inside the [Applications] folder.

**2** Double-click the [ACDSee 2 for Mac] icon.  
ACDSee starts and the main browser window appears.

### ACDSee Browser Interface



8

#### **A Menu bar**

Provides access to the various menu commands.

#### **B Toolbar**

Provides quick access to frequently used tasks and functions.

#### **C Folders pane**

Displays the configuration of folders in your Macintosh. When you browse a folder, the contents of the folder appear in the File List pane.

#### **D Preview pane**

Displays a preview of the image or media file currently selected in the File List pane. You can change the size of the preview image or play back the media file.

## E Favorites pane

You can add frequently used items (folders, etc.).

## F File List pane

Displays the contents of the selected folder or the results of the most recent search (the file or folder that matches the search item). It is the only pane that always appears in the browser and it cannot be hidden or closed.

## G Status bar

Displays information and properties for the selected file.

## Viewing Images

- 1 Select and click the folder containing the image you want to view in the Folders pane of the ACDSee browser.**

Images are displayed in the File List pane.

- 2 Select and double-click the image you want to view in the File List pane.**

The selected image is displayed.  
You can enlarge/reduce the display size of the image.



## Details on How to Use “ACDSee 2 for Mac”

You can find more information on how to use “ACDSee 2 for Mac” by using the help pages.

- 1 Select [ACDSee 2 for Mac] from [Help] on the menu bar.**  
The help screen appears.
- 2 Click the desired topic.**  
The explanation is displayed.

# Memo

# 9 Appendix

---

<b>Functions Available for Each Shooting Mode .....</b>	<b>222</b>
<b>Messages .....</b>	<b>224</b>
<b>Troubleshooting .....</b>	<b>227</b>
<b>Default Settings .....</b>	<b>229</b>
<b>List of World Time Cities .....</b>	<b>234</b>
<b>Optional Accessories .....</b>	<b>235</b>
<b>Main Specifications .....</b>	<b>236</b>
<b>WARRANTY POLICY .....</b>	<b>240</b>
<b>Index .....</b>	<b>246</b>

# Functions Available for Each Shooting Mode

Yes: Can be set.

No: Cannot be set.

Function	Shooting Mode							
Face Priority On	Yes	Yes	Yes	Yes	Yes	Yes	Yes	Yes
Smile Capture	Yes	Yes	Yes	Yes	Yes	Yes	Yes	Yes
Face Priority Off	No	Yes	Yes	Yes	Yes	No	No	Yes
Blink Detection	Yes	Yes	Yes	Yes	Yes	Yes	Yes	No
Flash Mode	(Auto)	Yes	Yes	Yes	Yes	No	Yes	No
	(Flash Off)	Yes	Yes	Yes	Yes	Yes	Yes	Yes
	(Flash On)	Yes	Yes	No	No	Yes	Yes	No
	(Auto + Red-eye)	Yes	Yes	No	No	No	Yes	No
	(Flash On + Red-eye)	Yes	Yes	No	No	Yes	Yes	No
	(Soft Flash)	Yes	Yes	No	No	Yes	Yes	No
Drive Mode	(Standard)	Yes	Yes	Yes	Yes	Yes	Yes	Yes
	(Self-timer)	Yes	Yes	Yes	No	Yes	Yes	Yes
	(2 Sec. Self-timer)	Yes	Yes	Yes	No	Yes	Yes	Yes
	(Continuous Shooting)	No	Yes	No	No	No	Yes	No
	(Burst Shooting)	No	Yes	No	No	No	Yes	No
Focus Mode	<b>AF</b> (Standard)	Yes	Yes	Yes	No*1	Yes	Yes	Yes
	(Macro)	Yes	Yes	Yes	No*1	Yes	Yes	Yes
	<b>PF</b> (Pan Focus)	Yes	Yes	Yes	No*1	Yes	Yes	Yes
	(Infinity)	Yes	Yes	No	No	Yes	Yes	Yes
	<b>MF</b> (Manual Focus)	Yes	Yes	No	No	Yes	Yes	Yes
Recorded Pixels	Yes	Yes	No*2	No*3	Yes	Yes	No*4	Yes
White Balance	No*7	Yes	No*7	No*7	Yes	No*7	No*7	Yes
Focusing Area	No*8	Yes	No*8	No*8	Yes	Yes	Yes	Yes*9
AE Metering	No*10	Yes	No*10	No*10	Yes	No*10	No*10	No*10
Sensitivity	Yes	Yes	No*11	No*11	Yes	Yes	Yes	No*11
EV Compensation	No*13	Yes	No*13	Yes	Yes	Yes	Yes	Yes
Zoom	Yes	Yes	Yes*14	Yes	Yes	Yes	Yes	Yes*14
Sharpness	Yes	Yes	Yes	Yes	Yes	Yes	Yes	Yes
Saturation	No	Yes	No	No	Yes	No	No	Yes
Contrast	No	Yes	No	No	Yes	No	No	Yes
Date Imprint	Yes	Yes	No	No	Yes	Yes	Yes	No

\*1 Fixed at **PF** (Pictures are taken at the **AF** (Standard) setting when they can be focused by pressing the shutter release button halfway.)

\*2 Fixed at

\*3 Fixed at

\*4 Fixed at

\*5 Fixed at

\*6 Fixed at (Fixed at for the first frame)

\*7 Fixed at **AWB**

\*8 Fixed at [ ] (Multiple)

Shooting menu items not listed in this chart can be set in any shooting mode except for Green Mode. However, these settings may not function properly in certain shooting modes and setting conditions even if they can be selected. For further information, please refer to the pages listed below.

	Shooting Mode						Function	Page	
Yes	Yes	Yes	Yes	Yes	Yes	Yes	Face Priority On Smile Capture	p.70	
Yes	Yes	Yes	Yes	Yes	Yes	Yes	Face Priority Off		
Yes	Yes	Yes	Yes	Yes	No	No	Blink Detection	p.67	
Yes	Yes	No	Yes	Yes	Yes	Yes	(Auto)	Flash Mode	p.99
Yes	Yes	Yes	Yes	Yes	Yes	Yes	(Flash Off)		
Yes	Yes	No	Yes	Yes	Yes	Yes	(Flash On)		
Yes	Yes	No	Yes	Yes	Yes	Yes	(Auto + Red-eye)		
Yes	Yes	No	Yes	Yes	Yes	Yes	(Flash On + Red-eye)		
Yes	Yes	No	Yes	Yes	Yes	Yes	(Soft Flash)		
Yes	Yes	Yes	Yes	Yes	Yes	Yes	(Standard)	Drive Mode	—
Yes	Yes	Yes	Yes	Yes	Yes	Yes	(Self-timer) (2 Sec. Self-timer)		
Yes	Yes	No	No	Yes	No	No	(Continuous Shooting) (Burst Shooting)		p.92
Yes	Yes	No	Yes	Yes	Yes	Yes	<b>AF</b> (Standard) (Macro) <b>PF</b> (Pan Focus)	Focus Mode	p.101
Yes	Yes	Yes	Yes	Yes	Yes	Yes	(Infinity)		
Yes	Yes	No	Yes	Yes	Yes	Yes	<b>MF</b> (Manual Focus)		
Yes	No*3	Yes	No*4	No*5	No*6	No	Recorded Pixels	p.104	
No*7	Yes	No*7	Yes	No*7	Yes	Yes	White Balance	p.107	
Yes	Yes	No*8	Yes*9	Yes	Yes	Yes	Focusing Area	p.103	
No*10	Yes	No*10	Yes	No*10	Yes	Yes	AE Metering	p.109	
Yes	No*11	No*12	Yes	Yes	Yes	Yes	Sensitivity	p.110	
Yes	Yes	Yes	Yes	Yes	Yes	Yes	EV Compensation	p.106	
Yes	Yes*15	Yes	Yes	Yes*16	No	Yes	Zoom	p.76	
No	Yes	No	Yes	No	Yes	Yes	Sharpness	p.114	
							Saturation	p.114	
							Contrast	p.115	
Yes	Yes	Yes	Yes	Yes	Yes	Yes	Date Imprint	p.116	

\*9 (Automatic Tracking AF) is not available

\*10 Fixed at (Multi-segment)

\*11 Fixed at Auto

\*12 The sensitivity is fixed at its minimum setting

\*13 Fixed at  $\pm 0.0$

\*14 Intelligent Zoom is not available

\*15 Only Optical Zoom is available

\*16 Digital Zoom is not available

# Messages

Messages such as the following may appear on the display during camera operation.

Message	Description
Battery depleted	The battery is exhausted. Charge the battery using the battery charger (p.29).
Memory card full	The SD Memory Card is full and no more images can be saved. Insert a new SD Memory Card or delete unwanted images (p.35, p.142). Change the recorded pixels or quality level of recorded images and try again (p.154).
Memory card error	Shooting and playback are impossible due to a problem with the SD Memory Card. You may be able to display or copy the images on the card using a computer.
The built-in memory is not formatted	The data within the built-in memory are damaged. Format the built-in memory.
Card is not formatted	The SD Memory Card you have inserted is unformatted or has been formatted on a computer or other device and is not compatible with this camera. Format the SD Memory Card in the camera (p.184).
Card locked	The SD Memory Card is write-protected (p.37).
Compression error	This message occurs when the camera fails to compress an image. Change the quality level or recorded pixels of the image and try shooting or saving it again.
No image/sound	There are no image/sound files on the SD Memory Card.
Movie recording stopped	This message appears when the internal temperature of the camera has exceeded normal operating limits while recording a movie.
The camera will turn off to prevent damage from overheating	The camera turned off because it has overheated. Wait until it cools down and then turn it back on.
Deleting	This message appears when deleting an image or sound file.
Camera cannot play this image and sound	You are trying to play back an image or sound in a format not supported by this camera. You may be able to play it back on another brand of camera or on your computer.
Image folder cannot be created	The largest file number (9999) has been assigned to an image in the largest folder number (999) and no more images can be saved. Insert a new SD Memory Card or format the card (p.184).

Message	Description
Protected	The image or sound file you are trying to delete is protected.
Data being recorded	Displayed when you try to switch to  mode while an image is still being recorded, or when the protect setting or DPOF setting is being changed. It disappears after the image is recorded or the setting is changed.
Data being processed	Displayed when the camera takes more than five seconds to display an image due to image processing, or when the SD Memory Card or the built-in memory is being formatted.
Built-in memory full	Displayed if the built-in memory is full when saving a file.
No image to be processed	Displayed when there are no images or sound files.
This image/sound cannot be processed	Displayed for files that cannot be processed.
No card in the camera	Displayed when no SD Memory Card is inserted.
The built-in memory is not enough to copy images/sounds	Displayed when there is insufficient built-in memory to perform copying.
Cannot process correctly	Displayed when Red-eye Compensation processing fails.
Display image/sound from built-in memory	Displayed when the camera enters the built-in memory display.
This image cannot be registered as a Favorite	The selected image is not suitable for registration as a Favorite.
No images are available to register as a Favorite	There are no images suitable for registration as a Favorite.
No image.	There are no playable images in the Favorites.





Messages such as the following may appear on the display when using the PictBridge function.

Message	Description
Low paper level in the printer	The paper level of the printer is low.
No paper in the printer	There is no paper in the printer.
Paper stuck in the printer	The paper is stuck in the printer.
Low ink level in the printer	The ink level of the printer is low.
No ink in the printer	There is no ink in the printer.
Printer error	An error message has been sent from the printer.
Data error	A data error message has been sent from the printer.

Message	Description
Connection error Check printer	Displayed when a PictBridge connection fails.
Printing	Displayed when printing is being executed.
Printing is completed. Continue printing?	Displayed when printing completes.
Print canceled	Displayed when printing is canceled.
No image to be processed	Displayed when there are no images to print.
Wrong DPOF setting	Displayed when DPOF printing cannot be performed.

# Troubleshooting

Problem	Cause	Remedy
The camera will not turn on	The battery is not installed	Check if a battery is installed. If not, install a battery.
	The battery is installed incorrectly	Check orientation of the battery. Reinsert the battery according to the ⊕ ⊖ symbols in the battery compartment (p.30).
	The battery is exhausted	Charge the battery.
No image appears on the display	The camera is connected to a computer	The display is off when the camera is connected to a computer.
	The camera is connected to a TV	The display is off when the camera is connected to a TV.
The display is hard to see	The brightness level of the display is set too dark	Adjust the brightness level in [Brightness Level] in the [Setting] menu (p.194).
	Power Saving function is on	When the Power Saving function is on, the display automatically darkens after a certain amount of time. Press a button to return to the normal brightness level. Select [Off] in [Power Saving] in the [Setting] menu to turn the Power Saving function off (p.195).
The shutter will not release	The flash is charging	Pictures cannot be taken while the flash is charging. Wait until charging is finished.
	There is no available space on the SD Memory Card or in the built-in memory	Insert an SD Memory Card with available space or delete unwanted images (p.35, p.142).
	Recording	Wait until recording is finished.
The picture is dark when using the flash	The subject is too far away in a dark environment, such as a night scene	The picture becomes dark if the subject is too far away. Take pictures within the specified flash range.

Problem	Cause	Remedy
The subject is not in focus	The subject is difficult to focus on with autofocus	The camera may have difficulty in focusing on such subjects as: low contrast subjects (a white wall, a blue sky, etc.), dark subjects, finely-patterned objects, rapidly-moving objects. It is also difficult to get proper focus when shooting through a window or a net. Try shooting using the focus lock (p.66), or Manual Focus (p.102).
	The subject is not in the focusing area	Locate the desired subject in the focus frame (focusing area) in the center of the display. If it is difficult to do so, first lock the focus on the desired subject (focus lock), and then move the camera to recompose.
The flash does not discharge	The flash mode is set to  (Flash Off)	Set to Auto or  (Flash On) (p.99).
	The drive mode is set to  The focus mode is set to  The shooting mode is set to 	The flash does not discharge in these modes.
The USB connection with a personal computer does not function properly	The USB connection setting of the camera is set to [PictBridge]	Set the USB connection mode to [PC] (p.171).
The USB connection with a printer does not function properly	The USB connection setting of the camera is set to [PC]	Set the USB connection mode to [PictBridge] (p.171).



Very occasionally, static electricity may cause camera malfunction. In this case, remove the battery and install it again. If the camera is then working properly, normal condition is restored and you can continue using the camera.

# Default Settings

The table below lists the factory default settings.

The meaning of the indications for menu items with a default setting is explained below.

## Last Memory Setting

Yes : The current setting (last memory) is saved when the camera is turned off.

No : The setting returns to the default setting when the camera is turned off.

\* : The setting depends on the [Memory] setting (p.123).

— : N/A





## Reset Setting



Yes : The setting returns to the default setting with the Reset function (p.198).

No : The setting is saved even after reset.



— : N/A

## ● [📷 Rec. Mode] Menu Items

Item	Default Setting	Last Memory Setting	Reset Setting	Page	
Pixel Track SR	Auto	Yes	Yes	p.112	
Recorded Pixels	 (4000×3000)	Yes	Yes	p.104	
White Balance	<b>AWB</b> (Auto)	*	Yes	p.107	
Focusing Area	 (Multiple)	Yes	Yes	p.103	
AE Metering	 (Multi-segment)	*	Yes	p.109	
Sensitivity	Auto	*	Yes	p.110	
EV Compensation	±0.0	*	Yes	p.106	
Movie	Recorded Pixels	 (1280×720/15 fps)	Yes	Yes	p.121
	Movie SR	<input checked="" type="checkbox"/> (On)	Yes	Yes	p.122
Blink Detection	<input checked="" type="checkbox"/> (On)	Yes	Yes	p.111	
Digital Zoom	<input checked="" type="checkbox"/> (On)	*	Yes	p.77	
Instant Review	1 sec.	Yes	Yes	p.113	

Item		Default Setting	Last Memory Setting	Reset Setting	Page
Memory	Face Priority	<input type="checkbox"/> (Off)	Yes	Yes	p.70
	Flash Mode	<input checked="" type="checkbox"/> (On)	Yes	Yes	p.99
	Drive Mode	<input type="checkbox"/> (Off)	Yes	Yes	p.91 p.92
	Focus Mode	<input type="checkbox"/> (Off)	Yes	Yes	p.101
	Zoom Position	<input type="checkbox"/> (Off)	Yes	Yes	p.76
	MF Position	<input type="checkbox"/> (Off)	Yes	Yes	p.102
	White Balance	<input type="checkbox"/> (Off)	Yes	Yes	p.107
	Sensitivity	<input type="checkbox"/> (Off)	Yes	Yes	p.110
	EV Compensation	<input type="checkbox"/> (Off)	Yes	Yes	p.106
	AE Metering	<input type="checkbox"/> (Off)	Yes	Yes	p.109
	Digital Zoom	<input checked="" type="checkbox"/> (On)	Yes	Yes	p.77
	DISPLAY	<input type="checkbox"/> (Off)	Yes	Yes	p.20
File No.	<input checked="" type="checkbox"/> (On)	Yes	Yes	—	
Green Button	Green Mode	Yes	Yes	p.117	
Sharpness	 (Normal)	Yes	Yes	p.114	
Saturation	 (Normal)	Yes	Yes	p.114	
Contrast	 (Normal)	Yes	Yes	p.115	
Vertical Snap	According to initial setting	Yes	Yes	p.78	
Date Imprint	Off	Yes	Yes	p.116	













● [  Setting ] Menu Items

Item		Default Setting	LastMemory Setting	Reset Setting	Page
Sound	Operation Volume	3	Yes	Yes	p.185
	Playback Volume	3	Yes	Yes	
	Start-up Sound	1	Yes	Yes	
	Shutter Sound	1	Yes	Yes	
	Operation Sound	1	Yes	Yes	
	Self-timer Sound	1	Yes	Yes	
Date Adjust	Date Style (date)	According to initial setting	Yes	No	p.45 p.186
	Date Style (time)	24h	Yes	No	
	Date	1/1/2009	Yes	No	
	Time	According to initial setting	Yes	No	
World Time	Select Time	Same as  Hometown	Yes	Yes	p.189
	Destination (City)	According to initial setting	Yes	No	
	Destination (DST)	<input type="checkbox"/> (Off)	Yes	No	
	Hometown (City)	According to initial setting	Yes	No	
	Hometown (DST)	<input type="checkbox"/> (Off)	Yes	No	
Language/言語		According to initial setting	Yes	No	p.41 p.191
Folder Name		Date	Yes	Yes	p.192
USB Connection		PC	Yes	Yes	p.171
Video Out		According to initial setting	Yes	No	p.193
Brightness Level			Yes	Yes	p.194
Power Saving		5 sec.	Yes	Yes	p.195
Auto Power Off		3 min.	Yes	Yes	p.196
Reset		Cancel	—	—	p.198
Delete all images		Cancel	—	—	p.146
Format		Cancel	—	—	p.184

## ● Playback Mode Palette Items

Item		Default Setting	Last Memory Setting	Reset Setting	Page
Slideshow	Interval	3 sec.	Yes	Yes	p.133
	Screen Effect	Wipe	Yes	Yes	
	Sound Effect	<input checked="" type="checkbox"/> (On)	Yes	Yes	
Resize	Recorded Pixels	Depending on the picture taken	—	—	p.154
Cropping		Depending on the picture taken	—	—	p.155
Image/Sound Copy		Built-in memory → SD Memory Card	—	—	p.166
Image Rotation		Normal	—	—	p.138
Digital Filter		B&W	No	—	p.156
Movie Edit	Save as Still Image	—	—	—	p.164
	Divide Movies	—	—	—	
Frame Composite		Default1	Yes	Yes	p.161
Red-eye Compensation		—	—	—	p.160
Voice Memo		—	—	—	p.181
Protect	Single Image/ Sound	Depending on the recorded image/sound	—	—	p.148
	All Images/Sounds	Depending on the recorded image/sound	—	—	
DPOF	Single Image	Copies: 0	—	—	p.168
	All Images	Date: <input type="checkbox"/> (Off)	—	—	
Favorites		—	—	—	p.135
Image Recovery		Cancel	—	—	p.147
Start-up Screen		Off	Yes	Yes	p.197

## ● Key Operation

Item	Function	Default Setting	Last Memory Setting	Reset Setting	Page
 button	Operation Mode	 mode	—	—	—
Zoom lever	Zoom Position	Full wide-angle	*	No	p.76
Four-way controller	 Drive Mode	 (Standard)	*	Yes	p.91 p.92
	 Shooting Mode	 (Auto Picture)	Yes	Yes	p.67
	 Flash Mode	 (Auto)	*	Yes	p.99
	 Focus Mode	<b>AF</b> (Standard)	*	Yes	p.101
<b>MENU</b> button	Menu Display	Capture mode:  Rec. Mode] menu Playback mode:  Setting] menu	—	—	p.55
<b>OK/DISPLAY</b> button	Information Display	Normal	*	Yes	p.20
 button	Operation Mode	Face Priority On	*	Yes	p.70

# List of World Time Cities

**City:** indicates cities that can be set as either the Initial Setting (p.41) or the World Time (p.189).  
**Video Output Format:** indicates the video output format of the city set as the Initial Setting.

Region	City	Video Output Format	Region	City	Video Output Format
North America	Honolulu	NTSC	Africa/ West Asia	Istanbul	PAL
	Anchorage	NTSC		Cairo	PAL
	Vancouver	NTSC		Jerusalem	PAL
	San Francisco	NTSC		Nairobi	PAL
	Los Angeles	NTSC		Jeddah	PAL
	Calgary	NTSC		Tehran	PAL
	Denver	NTSC		Dubai	PAL
	Chicago	NTSC		Karachi	PAL
	Miami	NTSC		Kabul	PAL
	Toronto	NTSC		Male	PAL
	New York	NTSC		Delhi	PAL
Halifax	NTSC	Colombo		PAL	
Central and South America	Mexico City	NTSC		Kathmandu	PAL
	Lima	NTSC		Dacca	PAL
	Santiago	NTSC	East Asia	Yangon	NTSC
	Caracas	NTSC		Bangkok	PAL
	Buenos Aires	PAL		Kuala Lumpur	PAL
	Sao Paulo	PAL		Vientiane	PAL
Rio de Janeiro	NTSC	Singapore		PAL	
Europe	Lisbon	PAL		Phnom Penh	PAL
	Madrid	PAL		Ho Chi Minh	PAL
	London	PAL		Jakarta	PAL
	Paris	PAL		Hong Kong	PAL
	Amsterdam	PAL		Beijing	PAL
	Milan	PAL		Shanghai	PAL
	Rome	PAL		Manila	NTSC
	Copenhagen	PAL		Taipei	NTSC
	Berlin	PAL		Seoul	NTSC
	Prague	PAL	Tokyo	NTSC	
	Stockholm	PAL	Guam	NTSC	
	Budapest	PAL	Oceania	Perth	PAL
	Warsaw	PAL		Adelaide	PAL
	Athens	PAL		Sydney	PAL
	Helsinki	PAL		Noumea	PAL
Moscow	PAL	Wellington		PAL	
Africa/ West Asia	Dakar	PAL		Auckland	PAL
	Algiers	PAL		Pago Pago	NTSC
	Johannesburg	PAL			

# Optional Accessories

A number of dedicated accessories are available for this camera. Products marked with an asterisk (\*) are the same as those supplied with the camera.

- **Power supply**

- Rechargeable lithium-ion battery D-LI88 (\*)**

- Battery charger kit K-BC88 (\*)**

- (Battery charger D-BC88, AC plug cord)

- AC adapter kit K-AC88**

- (AC adapter D-AC64, DC coupler D-DC88, AC plug cord)

- The battery charger and AC plug cord are only sold as a set.

- **Cable**

- USB cable I-USB7 (\*)**

- AV cable I-AVC7 (\*)**

- **Strap**

- O-ST51 (\*)**

- O-ST24**                      Genuine leather strap

- O-ST8**                         Silver chain strap

- O-ST81**                      Waterproof strap

- **Camera case**

- O-CC78**

# Main Specifications

Type	Fully automatic compact digital still camera with built-in zoom lens	
Number of Effective Pixels	Approx. 12 megapixels	
Image Sensor	1/2.3 inch CCD	
Number of Recorded Pixels	Still	<p> <math>\overline{12M}</math> (4000×3000), <math>\overline{7M}</math> (3072×2304)  <math>\overline{5M}</math> (2592×1944), <math>\overline{3M}</math> (2048×1536)  <math>\overline{2.1M}</math> (16:9) (1920×1080), <math>\overline{1024}</math> (1024×768)  <math>\overline{640}</math> (640×480)         </p> <ul style="list-style-type: none"> <li>* Fixed at <math>\overline{3M}</math> (2048×1536) in Half-length Portrait mode.</li> <li>* Fixed at <math>\overline{5M}</math> (2592×1944) in Digital SR mode.</li> <li>* Fixed at <math>\overline{3M}</math> (2048×1536) in Frame Composite mode.</li> <li>* Fixed at <math>\overline{5M}</math> (2592×1944) in Digital Wide mode, however, the first frame uses <math>\overline{3M}</math> (2048×1536).</li> <li>* Fixed at <math>\overline{2M}</math> (1600×1200) for one frame in Digital Panorama mode.</li> <li>* Fixed at <math>\overline{640}</math> (640×480) in Blog mode.</li> <li>* Fixed at <math>\overline{5M}</math> (2592×1944) when the sensitivity is set to 3200 or 6400.</li> <li>* Fixed at <math>\overline{5M}</math> (2592×1944) in Burst Shooting mode.</li> </ul>
	Movie	<p> <math>\overline{1280}</math> (1280×720/15 fps), <math>\overline{640}</math> (640×480/30 fps)  <math>\overline{640}</math> (640×480/15 fps), <math>\overline{320}</math> (320×240/30 fps)  <math>\overline{320}</math> (320×240/15 fps)         </p>
Sensitivity (Standard Output Sensitivity)	Auto (ISO 64, 100, 200, 400, 800) Manual (ISO 64, 100, 200, 400, 800, 1600, 3200, 6400)	* The sensitivity is fixed at Auto (ISO 64 - 6400) in Digital SR mode.
File Format	Still	JPEG (Exif 2.2), DCF 2.0, DPOF, PictBridge, PRINT Image Matching III
	Movie	AVI (Motion JPEG), approx. 30fps/15fps, PCM system, monaural sound, Movie SR (Movie Shake Reduction)
	Sound	Voice memo, Voice recording: WAVE (PCM) system, monaural
Storage Media	Built-in memory (approx. 33.7 MB), SD Memory Card, SDHC Memory Card	

## Approximate Image Storage Capacity and Recording Time Still Pictures

	Built-in Memory	512 MB SD Memory Card
<b>12M</b> 4000×3000	7 pictures	107 pictures
<b>12M</b> 4000×3000	15 pictures	209 pictures
<b>7M</b> 3072×2304	21 pictures	299 pictures
<b>5M</b> 2592×1944	26 pictures	368 pictures
<b>3M</b> 2048×1536	42 pictures	592 pictures
<b>2.1M</b> 1920×1080	61 pictures	863 pictures
<b>1024</b> 1024×768	127 pictures	1777 pictures
<b>640</b> 640×480	240 pictures	3358 pictures

- The image storage capacity is for reference only. The actual image storage capacity may vary depending on the SD Memory Card and the subject.

## Movie/Sound

	Built-in Memory	512 MB SD Memory Card
<b>1280</b> (1280×720/15fps)	32 sec.	7 min. 31 sec.
<b>640</b> (640×480/30fps)	32 sec.	7 min. 31 sec.
<b>640</b> (640×480/15fps)	1 min. 3 sec.	14 min. 48 sec.
<b>320</b> (320×240/30fps)	51 sec.	11 min. 59 sec.
<b>320</b> (320×240/15fps)	1 min. 38 sec.	22 min. 53 sec.
Sound	26 min. 46 sec.	6 hr. 14 min. 15 sec.

- The above figures are based on our standard shooting conditions and may vary depending on the subject, shooting conditions and type of the SD Memory Card used.
- Recording can continue until the built-in memory or the SD Memory Card is full, or the size of the recorded movie reaches 2 GB (when using an SDHC card). If recording stops at 2 GB, start recording again to continue to record the rest of the movie in blocks of 2 GB.

White Balance	Auto, Daylight, Shade, Tungsten Light, Fluorescent Light, Manual	
Lens	Focal Length	4.9 mm - 19.6 mm (approx. 27.5 mm - 110 mm in 35 mm equivalent focal length)
	Aperture	F2.6 (W) - F5.8 (T)
	Lens Composition	7 elements in 6 groups (3 aspherical elements)
	Zoom Type	Electrically driven
Optical Zoom	4×	

Intelligent Zoom	Approx. 5.2× at <b>7m</b> (3072×2304), Approx. 25.0× at <b>640</b> (640×480) (when combined with optical zoom)	
Digital Zoom	Up to approx. 6.3× (combines with 4× optical zoom to give zoom magnification equivalent to approx. 25.0×)	
Motion Blur Reduction	Still	Pixel Track SR, Hi-sensitivity shake reduction mode (Digital SR)
	Movie	Movie shake reduction (Movie SR)
Display	2.7 inch LCD, approx. 230,000 dots, Wide viewing angle	
Playback modes	Single-frame, 4-frame, 9-frame, Enlargement (max. 10×, scrollable), Face Close-up Playback, Folder Display, Calendar Display, Sound Playback, Histogram Display, Deleting Selected Images, Slideshow, Resize, Cropping, Image&Sound Copy, Image Rotation, Digital Filter, Movie Playback/Edit (Save as still images, Divide a movie), Frame Composite, Red-eye Compensation, Voice Memo, Protect, DPOF, Favorites, Image Recovery, Start-up Image Setting	
Focus Modes	Autofocus, Macro, Pan Focus, Infinity, Manual Focus	
Focus	Type	TTL contrast detection system by sensor 9-point autofocus (multiple/spot/automatic tracking AF changeable)
	Focus range (From lens face)	Standard : 0.4 m - ∞ (Wide-angle) 0.5 m - ∞ (Telephoto)
		Macro : 0.1 m - 0.5 m (Wide-angle) 0.5 m - 0.7 m (Telephoto)
	* It is possible to switch to Pan Focus, Infinity and Manual Focus.	
* Face Recognition AF is available only while the camera recognizes the subject's face.		
	Focus Lock	By half-pressing the shutter release button
Exposure control	Metering System	Multi-segment metering, Center-weighted metering, Spot metering
	Exposure Compensation	±2 EV (can be set in 1/3 EV steps)
Face Priority	Recognition of up to 32 people's faces (up to 15 faces in the face recognition frame on the display), Smile Capture, Blink Detection * Face Recognition AE is available only while the camera recognizes the subject's face.	
Shooting modes	Auto Picture, Program, Night Scene, Night Scene Portrait, Half-length Portrait, Movie, Landscape, Flower, Portrait, Surf & Snow, Sport, Digital SR, Kids, Pet, Food, Fireworks, Frame Composite, Party, Natural Skin Tone, Candlelight, Text, Blog, Digital Wide, Digital Panorama, Green, Vertical Snap	
Digital Filters	B&W, Sepia, Red, Pink, Purple, Blue, Green, Yellow, Soft, Color extraction (Red, Green, Blue), Brightness	
Movie	Continuous Recording Time	Approx. 1 second - until built-in memory or SD Memory Card is full (however, maximum size is limited to 2 GB)
Shutter Speed	1/4000 sec. - 1/4 sec., max. 4 sec. (Night Scene mode)	

Built-in Flash	Modes	Auto, Flash Off, Flash On, Auto + Red-eye, Flash On + Red-eye, Soft Flash
	Flash Range	Wide-angle: approx. 0.2 m - 4.6 m (approx. 0.66 ft - 15 ft) (Sensitivity: in Auto condition) Telephoto: approx. 0.5 m - 2.1 m (approx. 1.64 ft - 6.9 ft) (Sensitivity: in Auto condition)
Drive Modes	Single-frame, Self-timer (approx. 10 sec., approx. 2 sec.), Continuous, Burst Shooting	
Self-timer	Electronic control type, control time: Approx. 10 sec., 2 sec.	
Time Function	World Time	75 cities (28 time zones)
Power Source	Rechargeable lithium-ion battery D-LI88, AC adapter kit (optional)	
Battery Life	Number of Recordable Images approx. 200 pictures	* Recording capacity shows approximate number of shots recorded during CIPA-compliant testing (with display on, flash used for 50% of the shots, and 23 degrees centigrade). Actual performance may vary according to operating conditions.
	Playback Time approx. 220 min.	* According to the result of in-house testing. Actual time may differ depending on usage conditions.
	Movie Recording Time approx. 80 min.	
	Sound Recording Time approx. 250 min.	
Interfaces	USB 2.0 (high-speed compatible) /PC/AV terminal	
Video Output	NTSC/PAL (monaural)	
PictBridge	Printer	PictBridge-compatible printer
	Print Modes	Print One, Print All, DPOF AUTOPRINT
	Paper Size	Card, L, 2L, Postcard, 100 mm×150 mm, 4"×6", 8"×10", Letter, 11"×17", A4, A3, printer setting
	Paper Type	★★★, ★★, ★, printer setting
	Quality	★★★, ★★, ★, printer setting
	Border Status	With/without, printer setting
Dimensions	Approx. 97 (W) × 54 (H) × 21.5 (D) mm (excluding operating or protruding parts)	
Weight	Approx. 110 g (excluding battery and SD Memory Card) Approx. 125 g (including battery and SD Memory Card)	
Accessories	Rechargeable lithium-ion battery, battery charger, AC plug cord, USB cable, AV cable, software (CD-ROM), strap, Operating Manual, Quick Guide	

# WARRANTY POLICY

All PENTAX cameras purchased through authorized bona fide photographic distribution channels are guaranteed against defects of material or workmanship for a period of twelve months from date of purchase. Service will be rendered, and defective parts will be replaced without cost to you within that period, provided the equipment does not show evidence of impact, sand or liquid damage, mishandling, tampering, battery or chemical corrosion, operation contrary to operating instructions, or modification by an unauthorized repair shop. The manufacturer or its authorized representatives shall not be liable for any repair or alterations except those made with its written consent and shall not be liable for damages from delay or loss of use or from other indirect or consequential damages of any kind, whether caused by defective material or workmanship or otherwise; and it is expressly agreed that the liability of the manufacturer or its representatives under all guarantees or warranties, whether expressed or implied, is strictly limited to the replacement of parts as hereinbefore provided. No refunds will be made on repairs by non-authorized PENTAX service facilities.

## Procedure During 12-month Warranty Period

Any PENTAX which proves defective during the 12-month warranty period should be returned to the dealer from whom you purchased the equipment or to the manufacturer. If there is no representative of the manufacturer in your country, send the equipment to the manufacturer, with postage prepaid. In this case, it will take a considerable length of time before the equipment can be returned to you owing to the complicated customs procedures required. If the equipment is covered by warranty, repairs will be made and parts replaced free of charge, and the equipment will be returned to you upon completion of servicing. If the equipment is not covered by warranty, regular charges of the manufacturer or of its representatives will apply. Shipping charges are to be borne by the owner. If your PENTAX was purchased outside of the country where you wish to have it serviced during the warranty period, regular handling and servicing fees may be charged by the manufacturer's representatives in that country. Notwithstanding this, your PENTAX returned to the manufacturer will be serviced free of charge according to this procedure and warranty policy. In any case, however, shipping charges and customs clearance fees to be borne by the sender. To prove the date of your purchase when required, please keep the receipt or bills covering the purchase of your equipment for at least a year. Before sending your equipment for servicing, please make sure that you are sending it to the manufacturer's authorized representatives or their approved repair shops, unless you are sending it directly to the manufacturer. Always obtain a quotation for the service charge, and only after you accept the quoted service charge, instruct the service station to proceed with the servicing.

- This warranty policy does not affect the customer's statutory rights.
- The local warranty policies available from PENTAX distributors in some countries can supersede this warranty policy. Therefore, we recommend that you review the warranty card supplied with your product at the time of purchase, or contact the PENTAX distributor in your country for more information and to receive a copy of the warranty policy.



The CE Mark is a Directive conformity mark of the European Union.

## **For customers in USA**

### **STATEMENT OF FCC COMPLIANCE**

This device complies with Part 15 of the FCC Rules. Operation is subject to the following two conditions: (1) This device may not cause harmful interference, and (2) this device must accept any interference received, including interference that may cause undesired operation.

Changes or modifications not approved by the party responsible for compliance could void the user's authority to operate the equipment.

This equipment has been tested and found to comply with the limits for a Class B digital device, pursuant to part 15 of the FCC Rules.

These limits are designed to provide reasonable protection against harmful interference in a residential installation. This equipment generates, uses and can radiate frequency energy and, if not installed and used in accordance with the instructions, may cause harmful interference to radio communications. However, there is no guarantee that interference will not occur in a particular installation.

If this equipment does cause harmful interference to radio or television reception, which can be determined by turning the equipment off and on, the user is encouraged to try to correct the interference by one or more of the following measures:

- Reorient or relocate the receiving antenna.  
Increase the separation between the equipment and receiver.  
Connect the equipment into an outlet on a circuit different from that to which the receiver is connected.
- \* Consult the dealer or an experienced radio/TV technician for help.

## **For customers in Canada**

This Class B digital apparatus complies with Canadian ICES-003.

9

### **Pour les utilisateurs au Canada**

Cet appareil numérique de la classe B est conforme à la norme NMB-003 du Canada.

### **FOR CALIFORNIA, U.S.A. ONLY**

Perchlorate Material-special handling may apply. The lithium battery used in this camera contains perchlorate material, which may require special handling. See [www.dtsc.ca.gov/hazardouswaste/perchlorate](http://www.dtsc.ca.gov/hazardouswaste/perchlorate)

**Declaration of Conformity**  
According to 47CFR, Parts 2 and 15 for  
**Class B Personal Computers and Peripherals**

We: PENTAX Imaging Company  
A Division of PENTAX of America, Inc.

Located at: 600 12<sup>th</sup> Street, Suite 300  
Golden, Colorado 80401 U.S.A.  
Phone: 303-799-8000 FAX: 303-790-1131

Declare under sole responsibility that the product identified herein complies with 47CFR Parts 2 and 15 of the FCC rules as a Class B digital device. Each product marketed is identical to the representative unit tested and found to be compliant with the standards. Records maintained continue to reflect the equipment being produced can be expected to be within the variation accepted, due to quantity production and testing on the statistical basis as required by 47CFR §2.909. Operation is subject to the following two conditions: (1) This device may not cause harmful interference, and (2) This device must accept any interference received, including interference that may cause undesired operation. The above named party is responsible for ensuring that the equipment complies with the standards of 47CFR §15.101 to §15.109.

Product Name: PENTAX Digital Still Camera

Model Number: Optio P70

Contact person: Customer Service Manager

Date and Place: February, 2009, Colorado

## Information for Users on Collection and Disposal of Old Equipment and Used Batteries



### 1. In the European Union

These symbols on the products, packaging and/or accompanying documents mean that used electrical and electronic equipments and batteries should not be mixed with general household waste.

Used electrical/electronic equipments and batteries must be treated separately and in accordance with legislation that requires proper treatment, recovery and recycling of these products.

Following the implementation by member states, private households within the EU states may return their used electrical/electronic equipments and batteries to designated collection facilities free of charge\*.

In some countries your local retailer may also take back your old product free of charge if you purchase a similar new one.

\*Please contact your local authority for further details.



By disposing of this product correctly you will help ensure that the waste undergoes the necessary treatment, recovery and recycling and thus prevent potential negative effects on the environment and human health which could otherwise arise due to inappropriate waste handling.

### 2. In other countries outside the EU

These symbols are only valid in the European Union. If you wish to discard these items, please contact your local authorities or dealer and ask for the correct method of disposal.



Cd

For Switzerland: Used electrical/electronic equipment can be returned free of charge to the dealer, even when you don't purchase a new product. Further collection facilities are listed on the home page of [www.swico.ch](http://www.swico.ch) or [www.sens.ch](http://www.sens.ch).

Note for the battery symbol (bottom two symbol examples): This symbol might be used in combination with a designation for the chemical element or compound in use. In this case you have to comply with the requirement set by the Directive for the chemicals involved.

# Memo

## Symbols

Mode .....	12, 54
Mode .....	12, 54
button .....	51, 53
button .....	50, 52
[ Rec. Mode]	
menu .....	59, 229
[ Setting] menu .....	60, 231
Green Mode .....	74
Delete .....	126, 142
Tele .....	76
Wide .....	76
Magnify .....	139
Four-/Nine-image	
display .....	128
Self-timer .....	91
Continuous Shooting ....	92
Burst Shooting .....	92
Auto Picture .....	72
Program .....	73
Night Scene .....	81
Night Scene Portrait ....	81
Half-length Portrait ....	82
Movie .....	119
Landscape .....	68
Flower .....	68
Portrait .....	82
Surf & Snow .....	86
Sport .....	86
Digital SR .....	81
Kids .....	84
Pet .....	85
Food .....	68
Fireworks .....	81
Frame Composite .....	89
Party .....	87

Natural Skin Tone .....	82
Candlelight .....	81
Text .....	88
Blog .....	69
Digital Wide .....	94
Digital Panorama .....	96

## A



AC adapter .....	33
ACDSee .....	200
Adding sound	
(Voice Memo) .....	181
AE Metering .....	109
Auto + Red-eye  .....	99
Auto <b>AWB</b> .....	107
Auto Picture Mode .....	72
Auto Power Off .....	196
Auto  .....	99
Automatic Tracking	
AF .....	70, 103
AV cable .....	151
AV equipment .....	151

## B



B&W filter .....	156
Basic Mode .....	74
Battery level indicator .....	32
Blink Detection .....	67, 111
Blog Mode .....	69
Brightness Filter .....	156
Brightness Level .....	194
Built-in memory .....	166
Built-in memory display .....	54
Burst Shooting  .....	92

## C

Calendar display .....	129
Camera Shake .....	112, 122

Candlelight Mode .....	81
Capture Mode Palette .....	67
Center-weighted metering  .....	109
Changing volume ...	180, 185
Charging a battery .....	29
Checking the Memory	
Card .....	39
City name .....	234
Color extraction filter .....	156
Color filter .....	156
Connecting to a printer ...	172
Connecting to a TV .....	151
Continuous Shooting  ...	92
Contrast .....	115
Copy .....	166
Cropping .....	155





## D

Date and time setting .....	45, 186
Date Imprint .....	116
Daylight  .....	107
Daylight saving time .....	44
Default setting .....	41, 229
Delete  .....	126, 142
Delete all images .....	146
Deleting sounds .....	143
Destination .....	189
Digital Filter .....	156
Digital SR .....	81
Digital Wide Mode .....	94
Digital Zoom .....	76, 77
Display brightness .....	194
Display Language .....	191
Dividing movies .....	165
DPOF printing .....	176
DPOF settings .....	168
Drive Mode .....	91, 92

## E

Editing Movies .....	164
Error messages .....	224
Exposure setting .....	106

## F

Face close-up playback ...	140
Face Recognition function .....	70
Favorites .....	135
File number .....	123
Filters .....	156
Fireworks Mode .....	81
Flash Mode .....	99
Flash Off  .....	99
Flash On + Red-eye  .....	99
Flash On  .....	99
Flower Mode .....	68
Fluores. Light  .....	107
Focus Mode .....	101
Focusing .....	101
Focusing Area .....	103
Folder display .....	129
Folder Name .....	192
Food Mode .....	68
Format .....	184
Four-image display  .....	128
Four-way controller ...	51, 53
Frame Composite .....	89, 161
Frame Rate .....	121

## G

Green Button .....	51, 53, 117
Green Mode .....	74
Guide Indications .....	25

## H

Half-length Portrait Mode .....	82
Histogram .....	25
Hometown .....	44, 189

<b>I</b>	
Image Recovery .....	147
Image Storage Capacity .....	237
Infinity ▲ .....	101
Info Display .....	22
Installing a battery .....	30
Installing the Software .....	202
Instant Review .....	67, 113
Intelligent Zoom .....	76

<b>K</b>	
Kids Mode .....	84

<b>L</b>	
Landscape Mode .....	68
Language setting .....	41, 191

<b>M</b>	
Macintosh .....	202
Macro 🍃 .....	101
Magnify 🔍 .....	139
Manual Focus <b>MF</b> .....	101
Manual 📷 .....	107
Memory .....	123
<b>MENU</b> button .....	51, 53
Movie .....	119
Movie SR (Movie Shake Reduction) Function .....	122
Multi-segment metering 📷 .....	109







<b>N</b>	
Natural Skin Tone Mode ....	82
Night Scene Mode .....	81
Night Scene Portrait Mode .....	81
Nine-image display 📷 .....	128
NTSC .....	193
Number of pixels .....	104

<b>O</b>	
<b>OK/DISPLAY</b> button .....	51, 53
Opening screen .....	197
Operating the Menus .....	55
Optional accessory .....	235

<b>P</b>	
PAL .....	193
Pan Focus <b>PF</b> .....	101
Panoramic Pictures .....	96
Party Mode .....	87
Pet Mode .....	85
Photo processing lab .....	168
PictBridge .....	171
Pixel Track SR .....	112
Playback .....	126, 127, 180, 182

Playback Mode	
Palette .....	130, 232
Playing back movies .....	127
Playing back sounds .....	180
Portrait Mode .....	82
Power Saving .....	195
Power switch ....	39, 40, 50, 52
Press fully (shutter release button) .....	66
Press halfway (shutter release button) .....	66
Printing .....	171
Product Registration .....	206
Program Mode .....	73
Protect 🔒 .....	148
Provided Software .....	200

<b>R</b>	
Rec. Mode Menu .....	59, 229
Recorded Pixels .....	104, 121
Recording movies .....	119
Recording sounds .....	178

Recovering images .....	147	Strap .....	28
Red-eye Compensation ...	160	Surf & Snow Mode .....	86
Red-eye reduction  .....	99	System Requirements .....	201
Registering menu items ...	117	<b>T</b>	
Reset .....	198	Text Mode .....	88
Resize .....	154	Time imprint .....	116
Rotating .....	138	Transfer mode .....	171
<b>S</b>		Tungsten Light  .....	107
Saturation .....	114	TV .....	151
Saving as still picture (movie) .....	165	<b>U</b>	
Saving pictures by date ...	192	USB Connection .....	171, 206
Saving settings .....	123	<b>V</b>	
Screen Effect .....	134	Vertical Snap .....	46, 78
SD Memory Card .....	35	Video output format .....	193, 234
Select Time .....	190	Voice Memo .....	181
Self-timer  .....	91	Voice Recording .....	178
Sensitivity .....	110	<b>W</b>	
Sepia filter .....	156	White Balance .....	107
Setting Menu .....	60, 231	Windows .....	201
Shade  .....	107	World Time .....	189
Sharpness .....	114	<b>Z</b>	
Shooting information .....	21	Zoom /  .....	76
Shooting Mode .....	67	Zoom lever .....	50, 52
Shutter release button .....	50, 52, 66		
Slideshow .....	133		
Smile Capture function .....	70		
Soft filter .....	156		
Soft Flash  .....	99		
Sound settings .....	185		
Sound types .....	186		
Specifications .....	236		
Sport Mode .....	86		
Spot AE metering  .....	109		
Standard <b>AF</b> .....	101		
Starting-up in the Playback Mode .....	40		
Start-up screen .....	197		

# Memo

# Memo

# Memo

# Memo

**HOYA CORPORATION**

**PENTAX Imaging Systems Division**

2-36-9, Maeno-cho, Itabashi-ku, Tokyo 174-8639, JAPAN  
(<http://www.pentax.jp>)

**PENTAX Europe GmbH  
(European Headquarters)**

Julius-Vosseler-Strasse 104, 22527 Hamburg, GERMANY  
(HQ - <http://www.pentaxeurope.com>)  
(Germany - <http://www.pentax.de>)

**PENTAX U.K. Limited**

PENTAX House, Heron Drive, Langley, Slough, Berks  
SL3 8PN, U.K.  
(<http://www.pentax.co.uk>)

**PENTAX France S.A.S.**

112 Quai de Bezons, B.P. 204, 95106 Argenteuil  
Cedex, FRANCE  
(<http://www.pentax.fr>)

**PENTAX Italia S.r.l.**

Via Dione Cassio 15, 20138 Milano, ITALY  
(<http://www.pentaxitalia.it>)

**PENTAX (Schweiz) AG**

Widenholzstrasse 1, 8304 Wallisellen, Postfach 367,  
8305 Dietlikon, SWITZERLAND  
(<http://www.pentax.ch>)

**PENTAX Imaging Company**

**A Division of PENTAX of America, Inc.**

(Headquarters)  
600 12th Street, Suite 300 Golden, Colorado 80401, U.S.A.  
(PENTAX Service Department)  
12061 Tejon St. STE 600 Westminster, Colorado  
80234, U.S.A. (<http://www.pentaximaging.com>)

**PENTAX Canada Inc.**

1770 Argentia Road Mississauga, Ontario L5N 3S7,  
CANADA (<http://www.pentax.ca>)

**PENTAX Trading  
(SHANGHAI) Limited**

23D, Jun Yao International Plaza, 789 Zhaojiabang  
Road, Xu Hui District, Shanghai, 200032 CHINA  
(<http://www.pentax.com.cn>)

<http://www.pentax.jp/english>

- Specifications and external dimensions are subject to change without notice.