

lenovo

ThinkCentre
User Guide

Note

Before using this information and the product it supports, be sure to read and understand the *ThinkCentre Safety and Warranty Guide* and "Notices," on page 69.

First Edition (December 2008)

© Copyright Lenovo 2008. All rights reserved.

LENOVO products, data, computer software, and services have been developed exclusively at private expense and are sold to governmental entities as commercial items as defined by 48 C.F.R. 2.101 with limited and restricted rights to use, reproduction and disclosure.

LIMITED AND RESTRICTED RIGHTS NOTICE: If products, data, computer software, or services are delivered pursuant a General Services Administration "GSA" contract, use, reproduction, or disclosure is subject to restrictions set forth in Contract No. GS-35F-05925.

Contents

Important safety information v

Chapter 1. Product overview 1

Features	1
Specifications	4
Software overview	5
Software provided with your Windows operating system	5
Antivirus software	6
Locations	7
Locating connectors on the front of your computer	7
Locating connectors on the rear of your computer	8
Locating components	10
Locating parts on the system board	11

Chapter 2. Installing options and replacing hardware 13

Handling static-sensitive devices	13
Installing options and replacing hardware	13
Installing external options	14
Removing the computer cover	14
Accessing the system board components and drives	15
Installing or replacing a memory module	17
Installing or replacing an adapter card	19
Installing internal drives	22
Replacing the hard disk drive	26
Replacing the optical drive	28
Replacing the diskette drive or card reader	29
Replacing the battery	30
Replacing the heat sink and fan assembly	32
Replacing the system fan assembly	33
Replacing the internal speaker	34
Replacing the keyboard	36
Replacing the mouse	37
Completing the parts replacement	37
Installing security features	38
Integrated cable lock	39
Padlock	40
Password protection	40
Erasing lost or forgotten passwords (clearing CMOS)	40

Chapter 3. Recovery information 43

Creating and using Product Recovery discs	43
Performing backup and recovery operations	44
Using the Rescue and Recovery workspace	45
Creating and using rescue media	46
Creating and using a Recovery Repair diskette	47
Recovering or installing device drivers	48
Setting a rescue device in the startup sequence	48
Solving recovery problems	49

Chapter 4. Using the Setup Utility 51

Starting the Setup Utility program	51
Viewing and changing settings	51
Using passwords	51
Password considerations	52
User Password	52
Administrator Password	52
Setting, changing, and deleting a password	52
Enabling or disabling a device	52
Selecting a startup device	53
Selecting a temporary startup device	53
Selecting or changing the startup device sequence	54
Exiting from the Setup Utility program	54

Chapter 5. Updating system programs 55

Using system programs	55
Updating (flashing) BIOS from a diskette or disc	55
Updating (flashing) BIOS from your operating system	56
Recovering from a POST/BIOS update failure	56

Chapter 6. Troubleshooting and diagnostics 59

Basic troubleshooting	59
Diagnostic programs	60
Lenovo System Toolbox	61
PC-Doctor for Windows PE	61
PC-Doctor for DOS	62
Cleaning the mouse	63
Optical mouse	63
Non-optical mouse	63

Chapter 7. Getting information, help, and service 65

Information resources	65
Online Books folder	65
ThinkVantage Productivity Center	65
Access Help	66
Safety and Warranty	66
Lenovo Web site (http://www.lenovo.com)	66
Help and service	67
Using the documentation and diagnostic programs	67
Calling for service	67
Using other services	68
Purchasing additional services	68

Appendix. Notices 69

Television output notice	70
Trademarks	70

Index 71

Important safety information

CAUTION:

Before using this manual, be sure to read and understand all the related safety information for this product. Refer to the *ThinkCentre Safety and Warranty Guide* that you received with this product for the latest safety information. Reading and understanding this safety information reduces the risk of personal injury and or damage to your product.

If you no longer have a copy of the *ThinkCentre Safety and Warranty Guide*, you can obtain a Portable Document Format (PDF) version from the Lenovo® Support Web site at:

<http://www.lenovo.com/support>

Chapter 1. Product overview

This chapter provides an introduction to the features and options that are available for your computer. You can expand the capabilities of your computer by adding memory modules, drives, or adapter cards. When installing or replacing an option, use these instructions along with the instructions that come with the option.

Important: Before you install or replace any option, be sure to read and understand the “Important safety information” first. These precautions and guidelines will help you work safely.

Note: Use only computer parts provided by Lenovo.

Features

This section provides an overview of the computer features and preinstalled software.

System information

The following information covers a variety of models. For information about your specific model, use the Setup Utility. See Chapter 4, “Using the Setup Utility,” on page 51.

Microprocessor

- AMD Athlon™
- AMD Phenom™
- AMD Sempron™
- Internal cache (size varies by model type)

Memory

- Supports up to four DDR2 DIMMs (double data rate 2 dual inline memory modules)
- Flash memory for system programs (varies by model type)

Internal drives

- Diskette drive or card reader (varies by model type)
- Serial Advanced Technology Attachment (SATA) internal hard disk drive
- Optical drive (some models)

Video subsystem

- Integrated graphics controller for a VGA (Video Graphics Array) connector and a Digital Visual Interface (DVI) connector (dual display supported)
- PCI Express x16 graphics adapter card slot on the system board

Audio subsystem

- Audio line-in connector, audio line-out connector, and microphone connector on the rear panel
- High Definition (HD) with Realtek ALC662

- Microphone connector and headphone connector on the front panel
- Mono internal speaker

Connectivity

- 10/100/1000 Mbps integrated Ethernet controller
- Peripheral Component Interconnect (PCI) V.90 Data/Fax modem (some models)

System management features

- Ability to store power-on self-test (POST) hardware test results
- ASF 2.0 (Alert Standard Format Specification)
- Automatic power-on startup
- Preboot Execution Environment (PXE) and Dynamic Host Configuration Protocol (DHCP)
- Remote Administration
- System Management (SM) BIOS and SM software
- Wake on LAN[®]
- Wake on Ring (in the Setup Utility program, this feature is called Serial Port Ring Detect for an external modem)

Input/Output (I/O) features

- 9-pin serial port (some models)
- 25-pin Extended Capabilities Port (ECP)/Extended Parallel Port (EPP)
- DVI monitor connector
- Eight USB (Universal Serial Bus) connectors (two on the front panel and six on the rear panel)
- Ethernet connector
- One external Serial Advanced Technology Attachment (eSATA) connector through PCI bracket (some models)
- Standard keyboard connector
- Standard mouse connector
- Three audio connectors (audio line-in connector, audio line-out connector, and microphone connector) on the rear panel
- Two audio connectors (microphone connector and headphone connector) on the front panel
- VGA monitor connector

Expansion

- Three drive bays
- Two 32-bit PCI adapter card slots
- One PCI Express x1 adapter card slot
- One PCI Express x16 graphics adapter card slot

Power

- 280-watt auto-sensing power supply (some models)
- Automatic 50/60 Hz input frequency switching
- Advanced Configuration and Power Interface (ACPI) support

Security features

- Cover presence switch (also called intrusion switch) (some models)
- Diskette and hard disk drive I/O control
- Keyboard with fingerprint reader (some models, see the ThinkVantage® Productivity Center program for more information)
- Serial port and parallel port I/O control
- Startup sequence control
- Startup without diskette drive, keyboard, or mouse
- Support for the addition of an integrated cable lock (Kensington lock)
- Unattended start mode
- User and administrator passwords for BIOS access

Preinstalled software

Your computer might come with preinstalled software. If it does, an operating system, device drivers to support built-in features, and other support programs are included.

Operating system, preinstalled

Microsoft® Windows Vista®

Note: The Windows Vista operating system might not be available or supported in all countries or regions.

Operating systems, certified or tested for compatibility¹ (varies by model type)

- Microsoft Windows® XP
- Linux®

1. The operating systems listed here are being certified or tested for compatibility at the time this publication goes to press. Additional operating systems might be identified by Lenovo as compatible with your computer following the publication of this booklet. Corrections and additions to this list are subject to change. To determine if an operating system has been certified or tested for compatibility, check the Web site of the operating system vendor.

Specifications

This section lists the physical specifications for your computer.

Dimensions

Width: 331 mm (13.0 inches)

Height: 104 mm (4.1 inches)

Depth: 412 mm (16.2 inches)

Weight

Maximum configuration as shipped: 8.8 kg (19.4 lbs)

Environment

Air temperature:

Operating: 10° to 35°C (50° to 95°F)

Non-operating: -40° to 60°C (-40° to 140°F)

Humidity:

Operating: 10% to 80% (10% per hour, non condensing)

Non-operating: 10% to 90% (10% per hour, non condensing)

Maximum altitude:

Operating: -50 to 10,000 ft (-15.2 to 3048 m)

Non-operating: -50 to 35,000 ft (-15.2 to 10,668 m)

Electrical input

Input voltage:

Low range:

Minimum: 100 V AC

Maximum: 127 V AC

Input frequency range: 50/60 Hz

Voltage-selection switch setting: 115 V AC

High range:

Minimum: 200 V AC

Maximum: 240 V AC

Input frequency range: 50/60 Hz

Voltage-selection switch setting: 230 V AC

Software overview

The computer is manufactured with a preloaded operating system, Windows Vista, and several preloaded applications.

Software provided with your Windows operating system

This section describes the Windows applications provided with your computer.

Software provided by Lenovo

The following software applications are provided by Lenovo to help you improve productivity and reduce the cost associated with maintaining your computer.

Software provided with your computer may vary depending on your model type.

ThinkVantage Productivity Center: The ThinkVantage Productivity Center program guides you to a host of information and tools to help you set up, understand, maintain, and enhance your computer.

ThinkVantage Rescue and Recovery: The ThinkVantage Rescue and Recovery[®] (RnR) program is a one button recovery and restore solution that includes a set of self-recovery tools to help you diagnose computer problems, get help, and recover from system crashes quickly, even if the primary operating system could not start.

ThinkVantage Client Security Solution: The ThinkVantage Client Security Solution (CSS) is available on select Lenovo computers. It helps protect your information, including vital security information like passwords, encryption keys, and electronic credentials, while guarding against unauthorized user access to data.

ThinkVantage System Update: The ThinkVantage System Update (TVSU) is a software application that helps you keep the software on your system up-to-date, by downloading and installing software packages (TVT applications, device drivers, BIOS flashes, and other third party applications). Some examples of software that you should keep updated are programs provided by Lenovo, such as the Rescue and Recovery program and the Productivity Center program.

Fingerprint Software: The integrated fingerprint reader provided on some keyboards enables you to enroll your fingerprint and associate it with your power-on password, hard disk drive password, and Windows password. As a result, fingerprint authentication can replace passwords and enable simple and secure user access. A fingerprint reader keyboard is available with select computers or can be purchased for computers that support this option.

Lenovo System Toolbox

The Lenovo System Toolbox diagnostic program is preinstalled on your hard disk drive. This diagnostic program works through the Windows operating system to diagnose hardware problems and report operating-system-controlled settings that can cause hardware failures. See “Lenovo System Toolbox” on page 61 for more information.

PC-Doctor for Windows PE

The PC-Doctor for Windows PE diagnostic program is preinstalled on your hard disk drive. It is part of the Rescue and Recovery workspace on each Lenovo computer to diagnose hardware problems and report operating-system-controlled settings that can cause hardware failures. Use the PC-Doctor for Windows PE if you are unable to start the Windows operating system or if the Lenovo System Toolbox has not been successful in isolating a possible problem. See “PC-Doctor for Windows PE” on page 61 for more information.

Adobe Reader

The Adobe Reader is a tool used to view, print, and search PDF (Portable Document Format) documents.

See “Online Books folder” on page 65 for more information about accessing the online books and the Lenovo Web site.

Antivirus software

Your computer comes with antivirus software that you can use to detect and eliminate viruses. Lenovo provides a full version of antivirus software on your hard disk drive with a free 30-day subscription. After 30 days, you must renew the license to continue receiving the antivirus program updates.

For more information about updating your antivirus software, refer to the Access Help online help system. See “Access Help” on page 66 for instructions on how to open the online help system.

Locations

Locating connectors on the front of your computer

Figure 1 shows the location of the connectors on the front of your computer.

Note: Not all computer models have the following connectors.

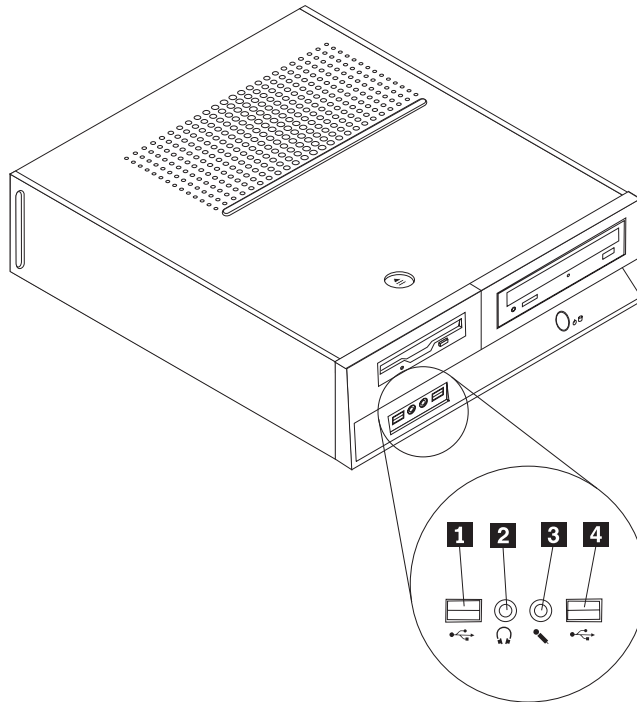

Figure 1. Front connector locations

1 USB connector

2 Headphone connector

3 Microphone connector

4 USB connector

Locating connectors on the rear of your computer

Figure 2 shows the location of the connectors on the rear of your computer. Some connectors on the rear of your computer are color-coded to help you determine where to connect the cables on your computer.

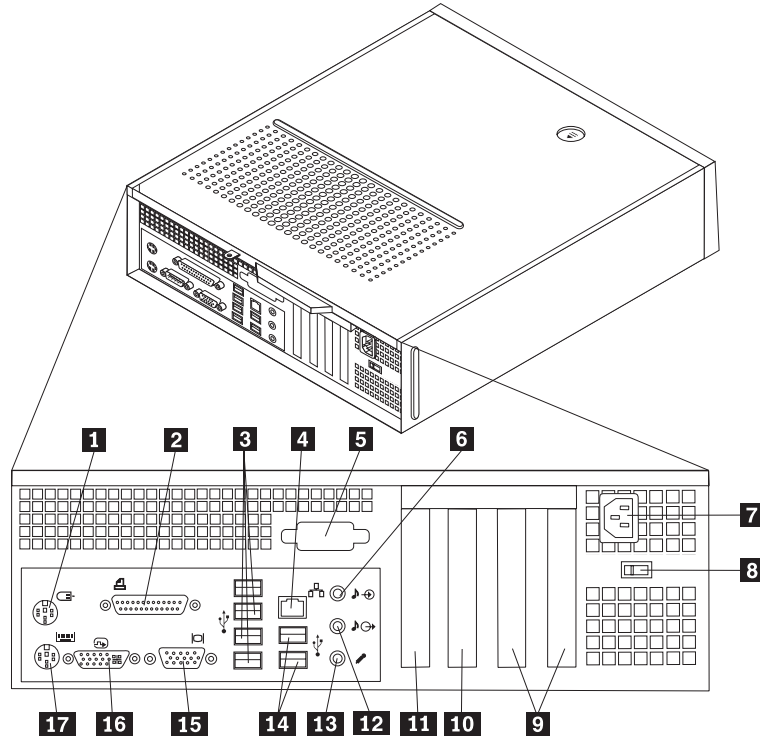

Figure 2. Rear connector locations

- | | |
|--|--|
| 1 Standard mouse connector | 10 PCI Express x16 graphics adapter card slot |
| 2 Parallel port | 11 PCI Express x1 adapter card slot |
| 3 USB connectors (4) | 12 Audio line-out connector |
| 4 Ethernet connector | 13 Microphone connector |
| 5 Serial port (some models) | 14 USB connectors (2) |
| 6 Audio line-in connector | 15 VGA monitor connector |
| 7 Power cord connector | 16 DVI monitor connector |
| 8 Voltage-selection switch
(some models) | 17 Standard keyboard connector |
| 9 Adapter card slots (2) | |

Connector	Description
Audio line-in connector	Used to receive audio signals from an external audio device, such as a stereo system. When you attach an external audio device, a cable is connected between the audio line-out connector of the device and the audio line-in connector of the computer.
Audio line-out connector	Used to send audio signals from the computer to external devices, such as powered stereo speakers (speakers with built-in amplifiers), headphones, multimedia keyboards, or the audio line-in connector on a stereo system or other external recording devices.
DVI monitor connector	Used to attach a DVI monitor or other devices that use a DVI monitor connector.
Ethernet connector	Used to attach an Ethernet cable for a local area network (LAN). Note: To operate the computer within FCC Class B limits, use a Category 5 Ethernet cable.
Microphone connector	Used to attach a microphone to your computer when you want to record sound or if you use speech-recognition software. This connector might be located on the front of the computer.
Parallel port	Used to attach a parallel printer, a parallel scanner, or other devices that use a 25-pin parallel port.
Serial port	Used to attach an external modem, a serial printer, or other devices that use a 9-pin serial port.
Standard keyboard connector	Used to attach a keyboard that uses a standard keyboard connector.
Standard mouse connector	Used to attach a mouse, trackball, or other pointing devices that use a standard mouse connector.
USB connector	Used to attach a device that requires a Universal Serial Bus (USB) connector, such as a USB keyboard, a USB mouse, a USB scanner, or a USB printer. If you have more than eight USB devices, you can purchase a USB hub, which you can use to connect additional USB devices.
VGA monitor connector	Used to attach a VGA monitor or other devices that use a VGA monitor connector.

Locating components

To remove the computer cover, see “Removing the computer cover” on page 14.

Figure 3 shows the location of the various components in your computer.

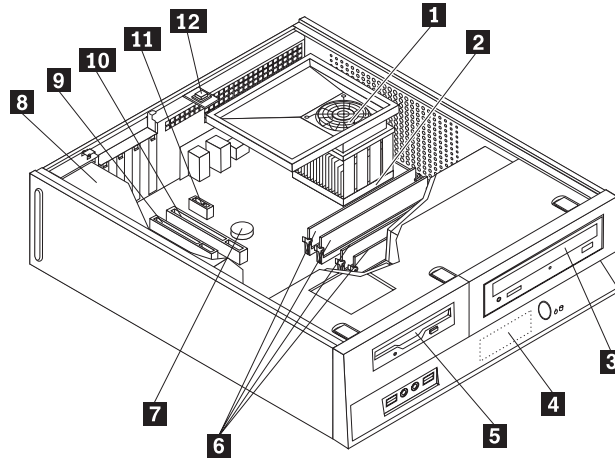

Figure 3. Component locations

- | | |
|---|--|
| 1 System fan plenum, system fan and heat sink assembly | 7 Battery |
| 2 Microprocessor | 8 Power supply assembly |
| 3 Optical drive | 9 Adapter card slot |
| 4 Hard disk drive (internal) | 10 PCI Express x16 graphics adapter card slot |
| 5 Diskette drive | 11 PCI Express x1 adapter card slot |
| 6 Memory modules (4) | 12 Cover presence (Intrusion) switch |

Locating parts on the system board

Figure 4 shows the location of the parts on the system board.

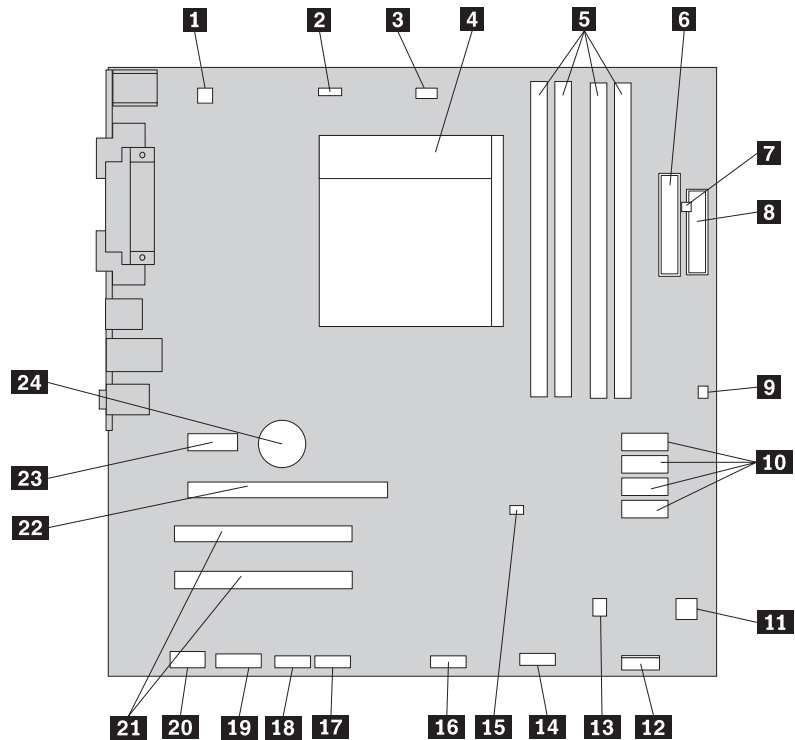

Figure 4. System board parts locations

- | | |
|--|--|
| 1 4-pin power connector | 13 Internal speaker connector |
| 2 System fan connector | 14 Front USB connector 2 |
| 3 Microprocessor fan connector | 15 Clear CMOS (Complementary Metal-Oxide Semiconductor)/Recovery jumper |
| 4 Microprocessor and heat sink assembly | 16 Front USB connector 1 |
| 5 Memory slots (4) | 17 Serial (COM2) connector |
| 6 24-pin power connector | 18 Serial (COM1) connector |
| 7 Thermal sensor connector | 19 CD-IN connector |
| 8 Diskette drive connector | 20 Front audio connector |
| 9 Cover presence (Intrusion) switch connector | 21 Adapter card slots (2) |
| 10 SATA connectors (4) | 22 PCI Express x16 graphics adapter card slot |
| 11 Power fan connector | 23 PCI Express x1 adapter card slot |
| 12 Front panel connector | 24 Battery |

Chapter 2. Installing options and replacing hardware

This chapter provides instructions for installing options and replacing hardware for your computer. You can expand the capabilities of your computer by adding memory modules, adapter cards, or drives. When installing or replacing an option, use these instructions along with the instructions that come with the option.

Handling static-sensitive devices

Do not open the static-protective package containing the new part until the defective part has been removed from the computer and you are ready to install the new part. Static electricity, although harmless to you, can seriously damage computer components and parts.

When you handle parts and other computer components, take these precautions to avoid static-electricity damage:

- Limit your movement. Movement can cause static electricity to build up around you.
- Always handle parts and other computer components carefully. Handle adapter cards, memory modules, system boards, and microprocessors by the edges. Never touch any exposed circuitry.
- Prevent others from touching the parts and other computer components.
- Before you replace a new part, touch the static-protective package containing the part to a metal expansion-slot cover or other unpainted metal surface on the computer for at least two seconds. This reduces static electricity in the package and your body.
- When possible, remove the new part from the static-protective packaging, and install it directly in the computer without setting the part down. When this is not possible, place the static-protective package that the part came in on a smooth, level surface and place the part on it.
- Do not place the part on the computer cover or other metal surface.

Installing options and replacing hardware

This section provides introductions for installing options and replacing hardware for your computer. When installing or replacing an option, use these instructions along with the instructions that come with the option.

Attention

Do not open your computer or attempt any repair before reading and understanding the "Important safety information" in the *ThinkCentre Safety and Warranty Guide* that came with your computer. To obtain a copy of the *ThinkCentre Safety and Warranty Guide*, go to: <http://www.lenovo.com/support>

Note: Use only computer parts provided by Lenovo.

Installing external options

External speakers, a printer, or a scanner can be connected to your computer. For some external options, you must install additional software in addition to making the physical connection. When installing an external option, see “Locating connectors on the front of your computer” on page 7 and “Locating connectors on the rear of your computer” on page 8 to identify the required connector, and then use the instructions that come with the option to help you make the connection and install any software or device drivers that are required for the option.

Removing the computer cover

Attention

Do not open your computer or attempt any repair before reading and understanding the “Important safety information” in the *ThinkCentre Safety and Warranty Guide* that came with your computer. To obtain a copy of the *ThinkCentre Safety and Warranty Guide*, go to: <http://www.lenovo.com/support>

This section provides instructions on how to remove the computer cover.

CAUTION:



Turn off the computer and wait three to five minutes to let the computer cool before removing the computer cover.

To remove the computer cover:

1. Remove any media from the drives, shut down your operating system, and turn off all attached devices and the computer.
2. Unplug all power cords from electrical outlets.
3. Disconnect all cables attached to the computer. This includes power cords, Input/Output (I/O) cables, and any other cables that are connected to the computer.
4. Remove any locking devices, such as a padlock that secures the computer cover.

5. Press the cover-release button on the top of the computer cover, slide the computer cover to the rear, and remove it. If your computer has screws that secure the computer cover, remove the screws, and then remove the computer cover.

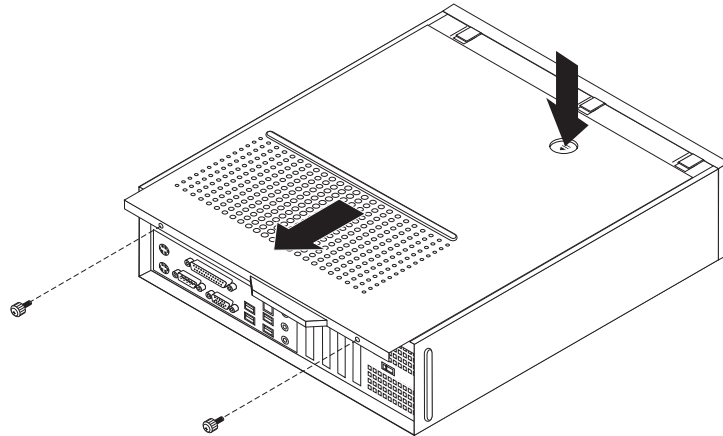

Figure 5. Removing the computer cover

Accessing the system board components and drives

Attention

Do not open your computer or attempt any repair before reading and understanding the “Important safety information” in the *ThinkCentre Safety and Warranty Guide* that came with your computer. To obtain a copy of the *ThinkCentre Safety and Warranty Guide*, go to: <http://www.lenovo.com/support>

This section provides instructions on how to access the system board components and drives. You might have to remove the drive bay assembly to access the system board components, such as memory modules and battery.

To access the system board components and drives:

1. Remove the computer cover. See “Removing the computer cover” on page 14.

2. Remove the front bezel by releasing the three tabs and pivoting the front bezel outward from the top.

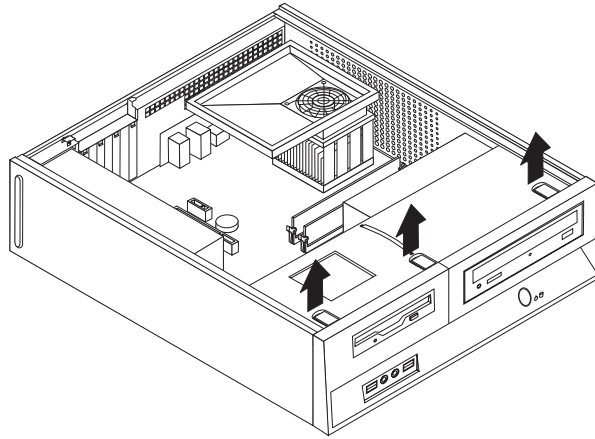

Figure 6. Removing the front bezel

3. In some models, you might have to remove the adapter cards to gain access to the system board components.

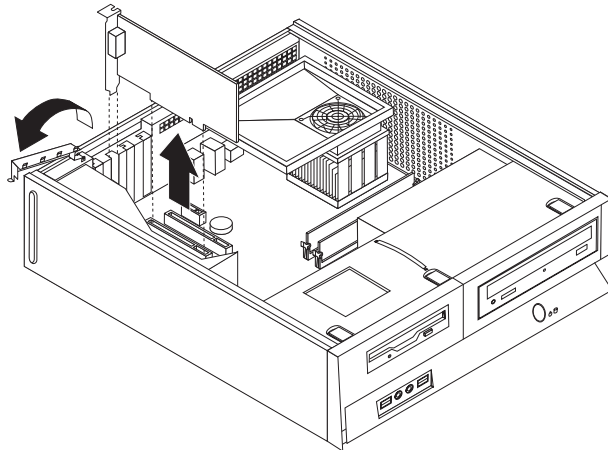

Figure 7. Removing the adapter card

- Using the blue handle **1**, lift and slide the drive bay assembly forward until the locating studs in the drive bay assembly are aligned with the slots on the sides of the chassis. Pull upward on the handle to remove the drive bay assembly completely from the chassis. Depending on what component of the computer you want to remove, you can either disconnect the cables from the rear of the drives or leave them connected.

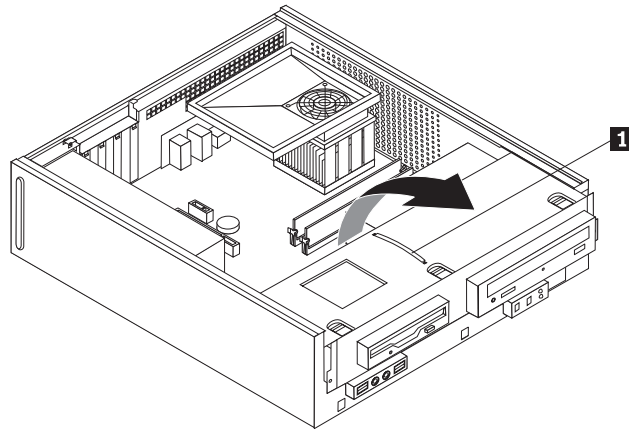

Figure 8. Removing the drive bay assembly

Installing or replacing a memory module

Attention

Do not open your computer or attempt any repair before reading and understanding the “Important safety information” in the *ThinkCentre Safety and Warranty Guide* that came with your computer. To obtain a copy of the *ThinkCentre Safety and Warranty Guide*, go to: <http://www.lenovo.com/support>

This section provides instructions on how to install or replace a memory module.

Your computer has four slots for installing or replacing DDR2 DIMMs (double data rate 2 dual inline memory modules) that provide up to a maximum of 8 GB of system memory.

When you install or replace a memory module, use the following guidelines:

- Use 1.8 V, 240-pin DDR2 SDRAM (double data rate 2 synchronous dynamic random access memory).
- Use 512 MB, 1 GB, or 2 GB memory modules in any combination up to a maximum of 8 GB.

Note: Only DDR2 SDRAM DIMMs can be used.

To install or replace a memory module:

1. Remove the computer cover. See “Removing the computer cover” on page 14.
2. You might have to remove the drive bay assembly to access the memory slots. See “Accessing the system board components and drives” on page 15.
3. Remove any parts that might prevent access to the memory slots.
4. Locate the memory slots. See Figure 4 on page 11.

5. Open the retaining clips.

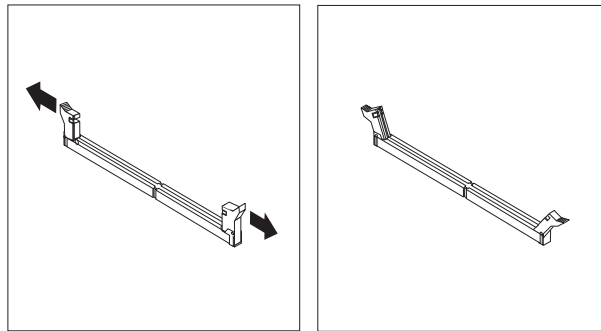

Figure 9. Opening the retaining clips

If you are replacing an old memory module, open the retaining clips and remove the memory module being replaced as shown.

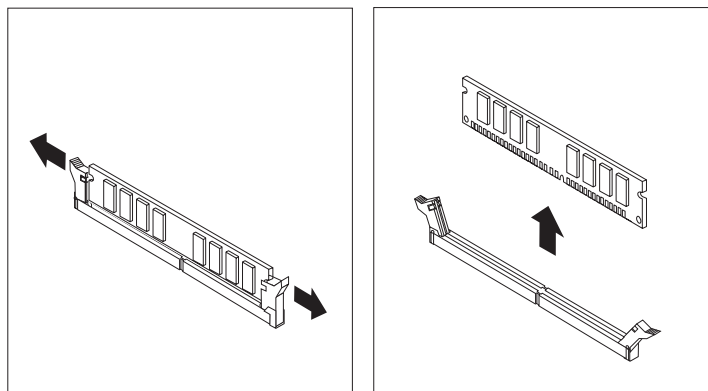

Figure 10. Removing the memory module

6. Position the memory module over the memory slot. Make sure that the notch **1** on the memory module aligns correctly with the slot key **2** on the system board. Push the memory module straight down into the slot until the retaining clips close.

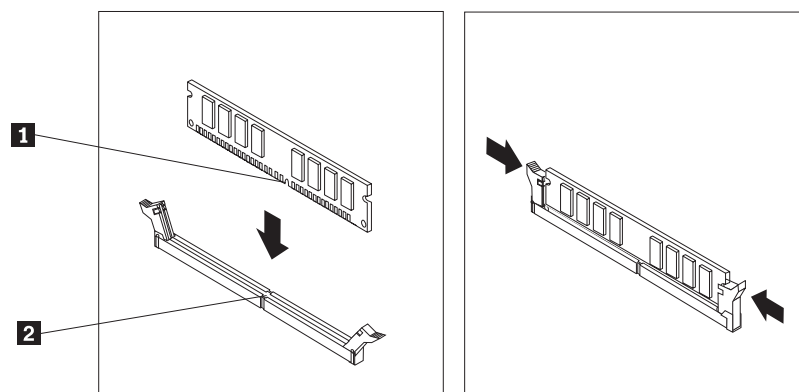

Figure 11. Installing the memory module

What to do next:

- To work with another option, go to the appropriate section.
- To complete the installation, go to “Completing the parts replacement” on page 37.

Installing or replacing an adapter card

Attention

Do not open your computer or attempt any repair before reading and understanding the “Important safety information” in the *ThinkCentre Safety and Warranty Guide* that came with your computer. To obtain a copy of the *ThinkCentre Safety and Warranty Guide*, go to: <http://www.lenovo.com/support>

This section provides instructions on how to install or replace an adapter card. Your computer has four expansion slots. There are two standard adapter card slots, one PCI Express x1 adapter card slot, and one PCI Express x16 graphics adapter card slot.

To install or replace an adapter card:

1. Remove the computer cover. See “Removing the computer cover” on page 14.
2. Open the adapter card latch and remove the slot cover for the appropriate expansion slot.

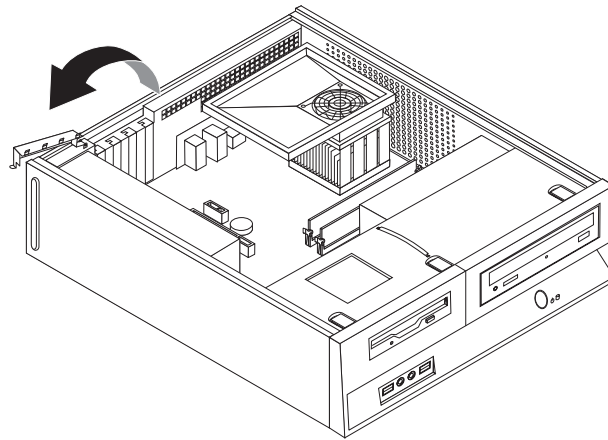

Figure 12. Opening the adapter card latch

If you are replacing an adapter card, open the adapter card latch and remove the failing adapter card.

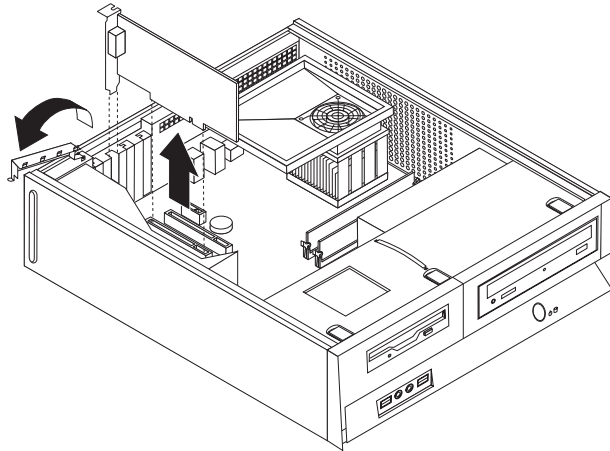
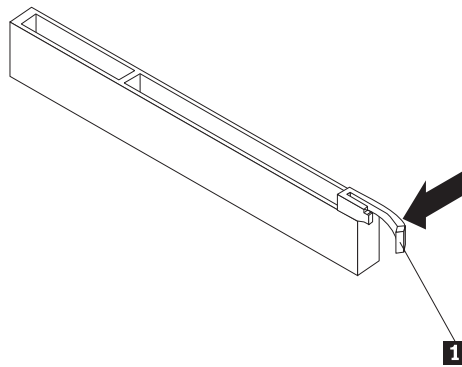

Figure 13. Removing the failing adapter card

Notes:

- a. The adapter card fits tightly into the card slot. If necessary, alternate moving each side of the adapter card a small amount until it is removed from the adapter card slot.
- b. If the adapter card is held in place by a retaining latch, press the adapter card retaining latch **1** downwards to disengage the latch. Grasp the adapter card and then gently pull the adapter card out of the slot.



3. Remove the new adapter card from its static-protective package.
4. Install the new adapter card into the appropriate slot on the system board.

5. Close the adapter card latch to secure the adapter card.

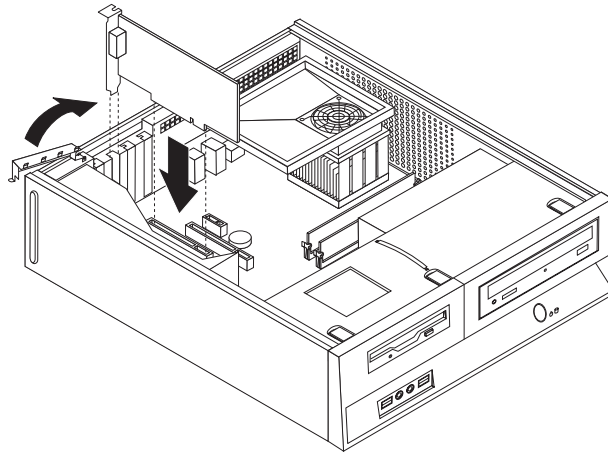

Figure 14. Installing the new adapter card

What to do next:

- To work with another option, go to the appropriate section.
- To complete the installation, go to “Completing the parts replacement” on page 37.

Installing internal drives

This section provides instructions on how to install the internal drives.

Internal drives are devices that your computer uses to read and store data. You can add drives to your computer to increase storage capacity and to enable your computer to read other types of media. Some of the types of drives that are available for your computer are:

- Serial Advanced Technology Attachment (SATA) hard disk drives
- SATA optical drives, such as CD drives or DVD drives
- Removable media drives

Note: These different drives are also referred to as integrated drive electronics (IDE) drives.

Internal drives are installed in bays. In this manual, the bays are referred to as bay 1, bay 2, and so on.

When you install an internal drive, it is important to note what type and size of drive that you can install in each bay. Also, it is important to correctly connect the internal drive cables to the installed drive.

Drive specifications

Your computer comes with the following factory-installed drives:

- An optical drive in bay 1 (some models)
- A 3.5-inch hard disk drive in bay 2
- A 3.5-inch diskette drive in bay 3 (some models)

Any bay that does not have a drive installed has a static shield and bay panel installed.

The following illustration shows the locations of the drive bays.

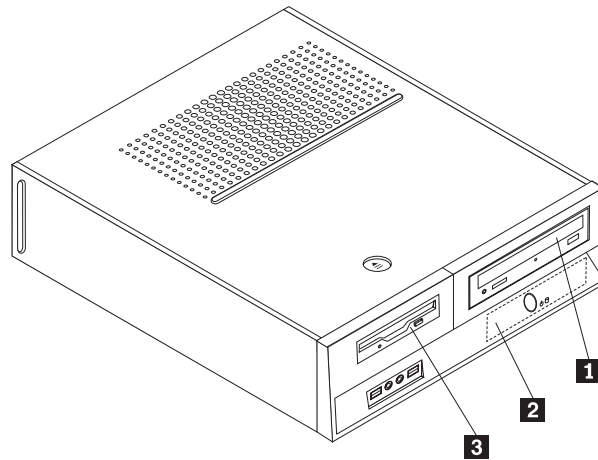

Figure 15. Drive bay locations

The following list describes the type and size of the drive that you can install in each bay:

- | | |
|---|--|
| 1 Bay 1 - Maximum height: 43.0 mm (1.7 inches) | Optical drives, such as a CD drive or a DVD drive (preinstalled in some models)
3.5-inch hard disk drive (requires a Universal Adapter Bracket, 5.25 to 3.5-inch) * |
| 2 Bay 2 - Maximum height: 26.1 mm (1.0 inch) | 3.5-inch hard disk drive (preinstalled) |
| 3 Bay 3 - Maximum height: 12.7 mm (0.5 inch) | 3.5-inch diskette drive (preinstalled in some models) |

* You can obtain a Universal Adapter Bracket, 5.25 to 3.5-inch, from a local computer retailer or by contacting the Customer Support Center.

Installing a drive in bay 1

Attention

Do not open your computer or attempt any repair before reading and understanding the “Important safety information” in the *ThinkCentre Safety and Warranty Guide* that came with your computer. To obtain a copy of the *ThinkCentre Safety and Warranty Guide*, go to: <http://www.lenovo.com/support>

To install an optical drive or an additional hard disk drive in bay 1:

1. Remove the computer cover. See “Removing the computer cover” on page 14.
2. Access the system board. See “Accessing the system board components and drives” on page 15.
3. If you are installing a drive with accessible media, such as an optical drive, remove the plastic panel in the front bezel by squeezing the plastic tabs that secure the panel on the inside of the front bezel.
4. Remove the metal shield from the drive bay.
5. For a 5.25-inch drive, install a retaining bracket on the side of the drive.

Note: If you are installing a 3.5-inch hard disk drive, you must use a Universal Adapter Bracket, 5.25 to 3.5-inch. You can obtain this bracket from a local computer retailer or by contacting the Customer Support Center.

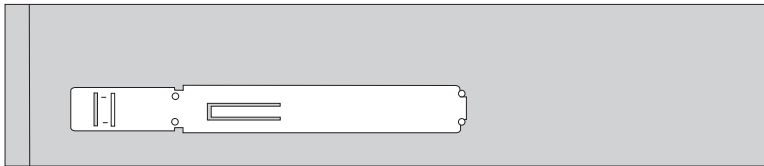

Figure 16. Retaining bracket

6. Align the drive bay assembly with the two slots and rails on the sides of the chassis, and install the drive into the drive bay until it snaps into position.

Note: When installing the Universal Adapter Bracket, if the retaining bracket is not available, install the screws to secure the Universal Adapter Bracket into the drive bay.

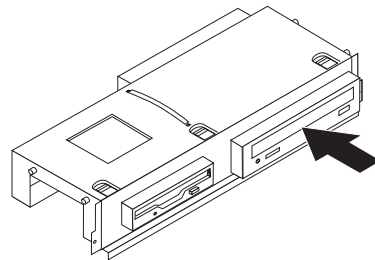

Figure 17. Installing the drive

7. Connect the new drive cable on the system board. See “Connecting a SATA drive” on page 25.

Connecting a SATA drive

A SATA optical drive or a SATA hard disk drive can be connected to any available SATA connector. To connect a SATA drive:

1. Locate the signal cable that comes with the new drive.
2. Locate the available SATA connector on the system board. See “Locating parts on the system board” on page 11.
3. Connect one end of the signal cable to the drive and the other to the available SATA connector on the system board.
4. Locate one of the extra five-wire power connectors and connect it to the drive.

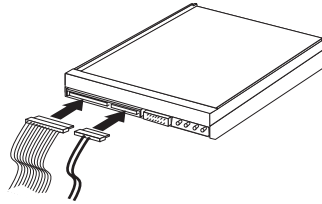

Figure 18. Connecting a serial ATA drive

What to do next:

- To work with another option, go to the appropriate section.
- To complete the installation, go to “Completing the parts replacement” on page 37.

Installing a diskette drive in bay 3

Attention

Do not open your computer or attempt any repair before reading and understanding the “Important safety information” in the *ThinkCentre Safety and Warranty Guide* that came with your computer. To obtain a copy of the *ThinkCentre Safety and Warranty Guide*, go to: <http://www.lenovo.com/support>

To install a diskette drive in bay 3:

1. Remove the computer cover. See “Removing the computer cover” on page 14.
2. Access the system board. See “Accessing the system board components and drives” on page 15.
3. Remove the metal shield from the diskette drive bay by using a flat-blade screwdriver to gently pry it loose.
4. Remove the plastic panel in the front bezel by squeezing the plastic tabs that secure the panel on the inside of the front bezel.
5. Install a retaining bracket on the side of the diskette drive.

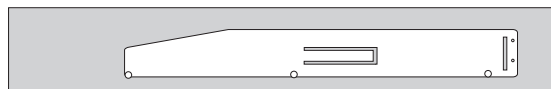

Figure 19. Retaining bracket

6. Align the drive bay assembly with the two slots and rails on the sides of the chassis, and install the diskette drive into the bay from the front until it snaps into position.

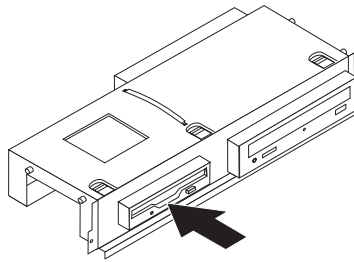

Figure 20. Installing the diskette drive

7. Connect the diskette drive cable to the appropriate connector on the system board. See “Locating parts on the system board” on page 11.
8. Connect the flat cable to the new drive.

What to do next:

- To work with another option, go to the appropriate section.
- To complete the installation, go to “Completing the parts replacement” on page 37.

Replacing the hard disk drive

Attention

Do not open your computer or attempt any repair before reading and understanding the “Important safety information” in the *ThinkCentre Safety and Warranty Guide* that came with your computer. To obtain a copy of the *ThinkCentre Safety and Warranty Guide*, go to: <http://www.lenovo.com/support>

This section provides instructions on how to replace the hard disk drive.

Important

When you receive a new hard disk drive, you also receive a set of *Product Recovery discs*. The set of *Product Recovery discs* enables you to restore the contents of the hard disk drive to the factory-installed state. For more information on recovering factory-installed software, refer to Chapter 3, “Recovery information,” on page 43.

To replace the hard disk drive:

1. Remove the computer cover. See “Removing the computer cover” on page 14.
2. Remove the front bezel and drive bay assembly. See “Accessing the system board components and drives” on page 15.

3. Use the blue handle to pivot the hard disk drive and bracket upward, slide the hard disk drive to the left until it is free from the retaining clips in the bottom of the chassis, and then completely remove it from the chassis.

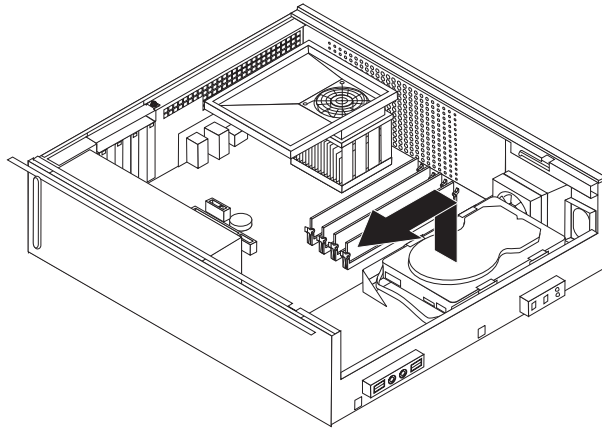

Figure 21. Removing the hard disk drive

4. Disconnect the signal and power cables from the rear of the hard disk drive.
5. To install a new hard disk drive into the blue bracket, flex the bracket and align pin **1**, pin **2**, pin **3**, and pin **4** on the bracket with the holes in the hard disk drive. Do not touch the circuit board **5** on the bottom of the hard disk drive.

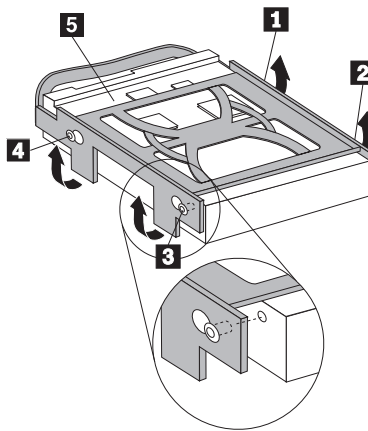

Figure 22. Aligning the pins with the holes in the hard disk drive

6. Reconnect the signal and power cables to the rear of the hard disk drive.
7. Position the hard disk drive and bracket so that it engages the retaining clips in the bottom of the chassis when you slide the bracket to the right.
8. Slide the hard disk drive and bracket to the right until it snaps into position.
9. Go to “Completing the parts replacement” on page 37.

Replacing the optical drive

Attention

Do not open your computer or attempt any repair before reading and understanding the “Important safety information” in the *ThinkCentre Safety and Warranty Guide* that came with your computer. To obtain a copy of the *ThinkCentre Safety and Warranty Guide*, go to: <http://www.lenovo.com/support>

This section provides instructions on how to replace the optical drive.

To replace the optical drive:

1. Remove the computer cover. See “Removing the computer cover” on page 14.
2. Remove the front bezel and drive bay assembly. See “Accessing the system board components and drives” on page 15.
3. Disconnect the signal and power cables from the rear of the optical drive.
4. Release the optical drive by pressing inward on the blue retainer at the side of the drive.
5. Slide the optical drive being replaced out the front of the drive bay assembly.

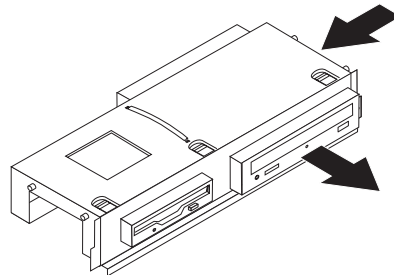

Figure 23. Removing the optical drive

6. Remove the retaining bracket from the failing optical drive and install it on the new optical drive.

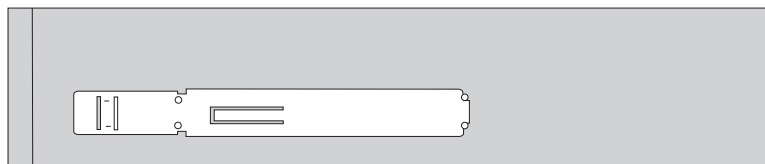

Figure 24. Retaining bracket for the optical drive

7. Install the new optical drive into the bay until it snaps into position.

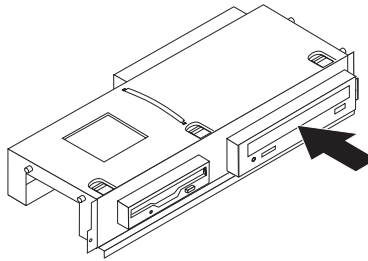

Figure 25. Installing the new optical drive

8. Reconnect the signal and power cables to the new optical drive.
9. Go to “Completing the parts replacement” on page 37.

Replacing the diskette drive or card reader

Attention

Do not open your computer or attempt any repair before reading and understanding the “Important safety information” in the *ThinkCentre Safety and Warranty Guide* that came with your computer. To obtain a copy of the *ThinkCentre Safety and Warranty Guide*, go to: <http://www.lenovo.com/support>

This section provides instructions on how to replace the diskette drive or card reader. Depending on your model type, your computer might have a diskette drive or a card reader installed.

The artwork in this section shows how to replace the diskette drive. To replace the card reader, the procedure is almost the same as replacing the diskette drive.

To replace the diskette drive or card reader:

1. Remove the computer cover. See “Removing the computer cover” on page 14.
2. Remove the front bezel and drive bay assembly. See “Accessing the system board components and drives” on page 15.
3. Disconnect the signal and power cables from the rear of the diskette drive or card reader.
4. Release the diskette drive or card reader by pressing inward on the blue retainer at the side of the drive.
5. Remove the failing diskette drive or card reader by sliding it out the front of the drive bay assembly.

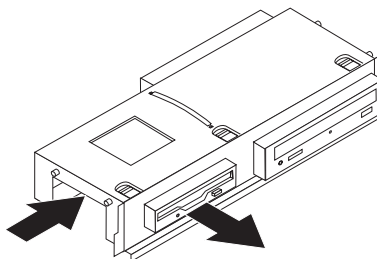

Figure 26. Removing the diskette drive or card reader

6. Remove the retaining bracket from the failing diskette drive or card reader and install it on the new diskette drive or card reader.

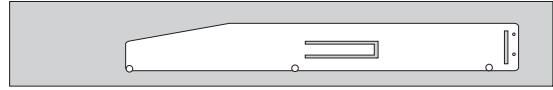

Figure 27. Retaining bracket for the diskette drive or card reader

7. Install the new diskette drive or card reader into the drive bay from the front until it snaps into position.

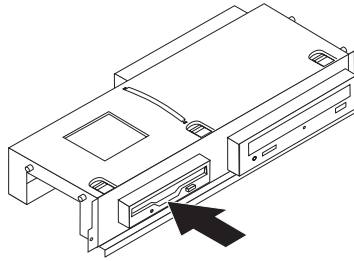

Figure 28. Installing the new diskette drive or card reader

8. Reconnect the signal and power cables to the rear of the new diskette drive or card reader.
9. Go to “Completing the parts replacement” on page 37.

Replacing the battery

Attention

Do not open your computer or attempt any repair before reading and understanding the “Important safety information” in the *ThinkCentre Safety and Warranty Guide* that came with your computer. To obtain a copy of the *ThinkCentre Safety and Warranty Guide*, go to: <http://www.lenovo.com/support>

This section provides instructions on how to replace the battery.

Your computer has a special type of memory that maintains the date, time, and settings for built-in features, such as parallel-port assignments (configuration). A battery keeps this information active when you turn off the computer.

The battery normally requires no charging or maintenance throughout its life; however, no battery lasts forever. If the battery fails, the date, time, and configuration information (including passwords) are lost. An error message is displayed when you turn on the computer.

Refer to the “Lithium battery notice” in the *ThinkCentre Safety and Warranty Guide* for information about replacing and disposing of the battery.

To replace the battery:

1. Remove the computer cover. See “Removing the computer cover” on page 14.
2. You might have to access the system board components. See “Accessing the system board components and drives” on page 15.

3. Locate the battery. See Figure 3 on page 10.
4. Remove the failing battery.

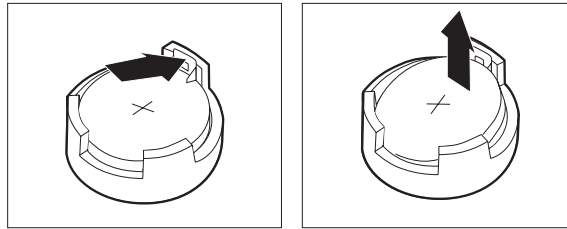

Figure 29. Removing the failing battery

5. Install a new battery.

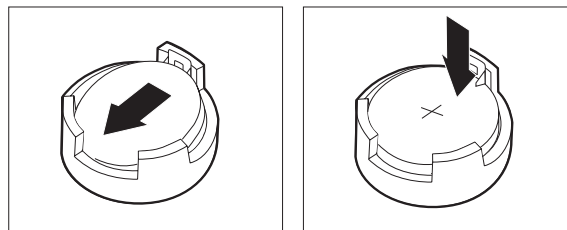

Figure 30. Installing a new battery

6. Reinstall the computer cover, and connect the cables. See “Completing the parts replacement” on page 37.

Note: When the computer is turned on for the first time after replacing the battery, an error message might be displayed. This is normal after replacing the battery.

7. Turn on the computer and all attached devices.
8. Use the Setup Utility program to set the date, time, and any passwords. See Chapter 4, “Using the Setup Utility,” on page 51.

Replacing the heat sink and fan assembly

Attention

Do not open your computer or attempt any repair before reading and understanding the “Important safety information” in the *ThinkCentre Safety and Warranty Guide* that came with your computer. To obtain a copy of the *ThinkCentre Safety and Warranty Guide*, go to: <http://www.lenovo.com/support>

This section provides instructions on how to replace the heat sink and fan assembly.

CAUTION:



The heat sink and fan assembly might be very hot. Turn off the computer and wait three to five minutes to let the computer cool before removing the computer cover.

To replace the heat sink and fan assembly:

1. Remove the computer cover. See “Removing the computer cover” on page 14.
2. Disconnect the heat sink and the fan assembly cable from the system board. See “Locating parts on the system board” on page 11.
3. Remove the fan plenum from the heat sink and fan assembly. See “Locating components” on page 10.
4. Pivot the handle **1** to release the heat sink clamp and then disengage the clamp from the plastic retention bracket.

Note: The system board for your computer might look different to the one illustrated below.

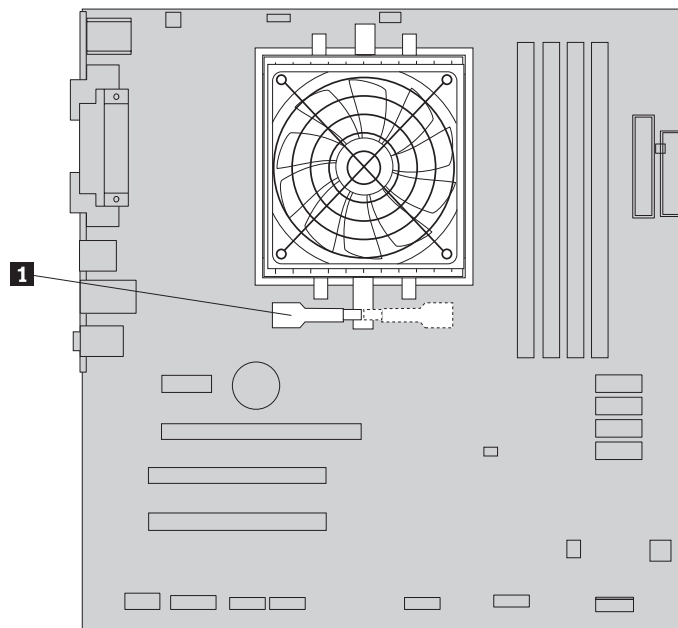

Figure 31. Removing the heat sink and fan assembly held in place by a clamp

Note: You might have to gently twist the heat sink and fan assembly to free it from the microprocessor.

5. Lift the failing heat sink and fan assembly off the system board.
6. Remove the mylar film that covers the greased side of the new heat sink and fan assembly that will face the microprocessor.
7. Position the heat sink and fan assembly on the microprocessor socket and then position the clamp on the plastic retention bracket. Pivot the handle **1** to clamp the heat sink and fan assembly to the plastic retention bracket.

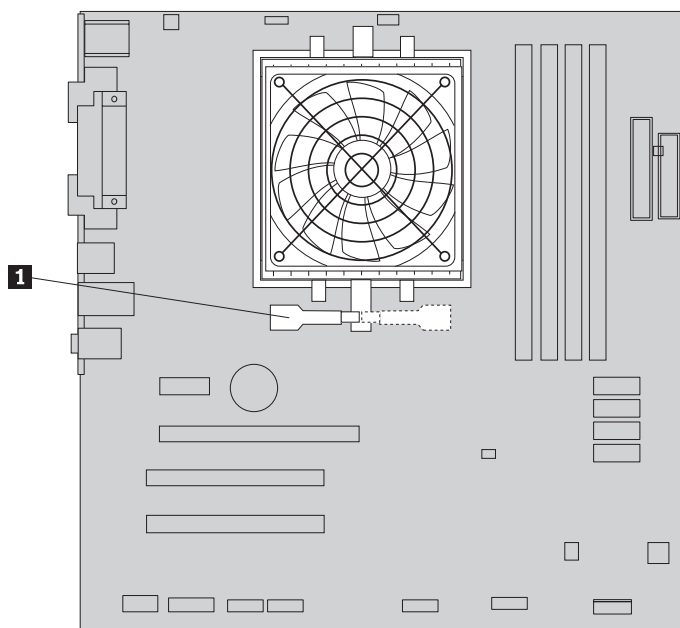

Figure 32. Clamping the heat sink and fan assembly to the plastic retention bracket

8. Reconnect the heat sink and the fan assembly cable to the microprocessor fan connector on the system board.
9. Go to “Completing the parts replacement” on page 37.

Replacing the system fan assembly

Attention

Do not open your computer or attempt any repair before reading and understanding the “Important safety information” in the *ThinkCentre Safety and Warranty Guide* that came with your computer. To obtain a copy of the *ThinkCentre Safety and Warranty Guide*, go to: <http://www.lenovo.com/support>

This section provides instructions on how to replace the system fan assembly.

To replace the system fan assembly:

1. Remove the computer cover. See “Removing the computer cover” on page 14.
2. Remove the front bezel and drive bay assembly. See “Accessing the system board components and drives” on page 15.
3. Disconnect the system fan assembly cable from the system board. See “Locating parts on the system board” on page 11.
4. Remove the hard disk drive. See “Replacing the hard disk drive” on page 26.

5. Remove the two screws that secure the system fan assembly.
6. Remove the system fan assembly by pulling the bracket outward and lifting it up from the system board to remove completely.

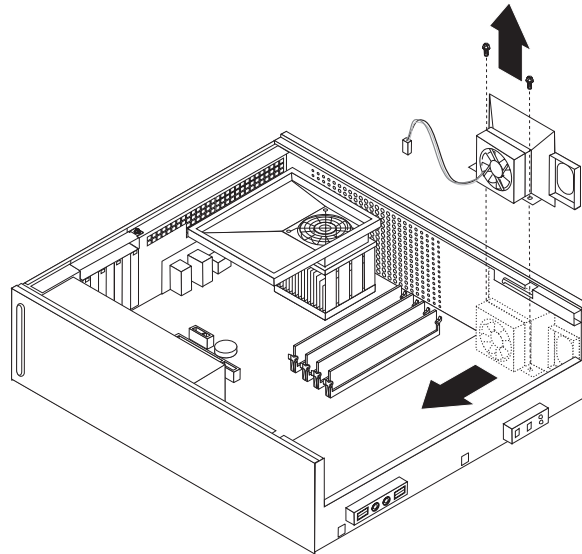

Figure 33. Removing the system fan assembly

7. Install a new system fan assembly and install the two screws that secure the system fan assembly.
8. Connect the system fan assembly cable to the system fan connector on the system board.
9. Reinstall the hard disk drive.
10. Go to “Completing the parts replacement” on page 37.

Replacing the internal speaker

Attention

Do not open your computer or attempt any repair before reading and understanding the “Important safety information” in the *ThinkCentre Safety and Warranty Guide* that came with your computer. To obtain a copy of the *ThinkCentre Safety and Warranty Guide*, go to: <http://www.lenovo.com/support>

This section provides instructions on how to replace the internal speaker.

To replace the internal speaker:

1. Remove the computer cover. See “Removing the computer cover” on page 14.
2. Remove the front bezel and drive bay assembly. See “Accessing the system board components and drives” on page 15.
3. You might have to remove the hard disk drive to gain easy access to the internal speaker. See “Replacing the hard disk drive” on page 26.
4. Locate the internal speaker connector on the system board. See “Locating parts on the system board” on page 11.
5. Disconnect the internal speaker cable from the system board.

6. Push upward on the clip that secures the internal speaker, pivot the internal speaker outward, and then completely remove it from the chassis.

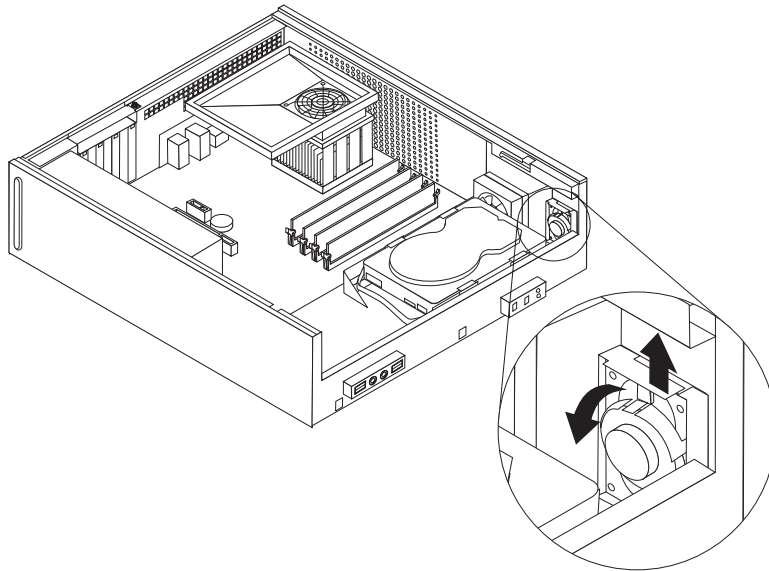

Figure 34. Removing the internal speaker

7. Position the bottom of the new internal speaker into the bracket and then pivot the top of the internal speaker until it snaps into position.
8. Connect the internal speaker cable to the system board. See “Locating parts on the system board” on page 11.
9. Reinstall the hard disk drive if it was removed.
10. Go to “Completing the parts replacement” on page 37.

Replacing the keyboard

Attention

Do not open your computer or attempt any repair before reading and understanding the “Important safety information” in the *ThinkCentre Safety and Warranty Guide* that came with your computer. To obtain a copy of the *ThinkCentre Safety and Warranty Guide*, go to: <http://www.lenovo.com/support>

This section provides instructions on how to replace the keyboard.

To replace the keyboard:

1. Remove any media from the drives, shut down your operating system, and turn off all attached devices and the computer.
2. Unplug all power cords from electrical outlets.
3. Locate the keyboard connector.

Note: Your keyboard might be connected to a standard keyboard connector **1** or a USB connector **2**. Depending on where your keyboard is connected, see “Locating connectors on the rear of your computer” on page 8 or “Locating connectors on the front of your computer” on page 7.

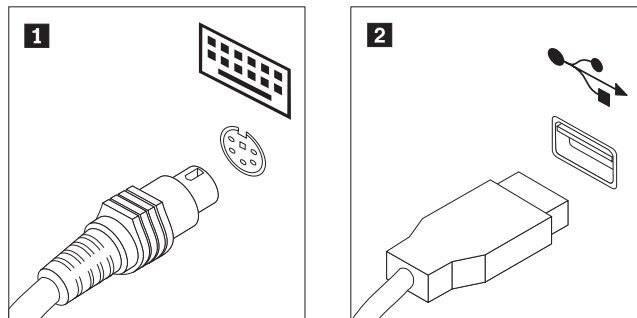

Figure 35. Keyboard connectors

4. Disconnect the failing keyboard cable from the computer.
5. Connect a new keyboard to the appropriate connector on the computer.
6. Go to “Completing the parts replacement” on page 37.

Replacing the mouse

Attention

Do not open your computer or attempt any repair before reading and understanding the “Important safety information” in the *ThinkCentre Safety and Warranty Guide* that came with your computer. To obtain a copy of the *ThinkCentre Safety and Warranty Guide*, go to: <http://www.lenovo.com/support>

This section provides instructions on how to replace the mouse.

To replace the mouse:

1. Remove any media from the drives, shut down your operating system, and turn off all attached devices and the computer.
2. Unplug all power cords from electrical outlets.
3. Locate the connector for the mouse.

Note: Your mouse might be connected to a standard mouse connector **1** or a USB connector **2**. Depending on where your mouse is connected, see “Locating connectors on the rear of your computer” on page 8 or “Locating connectors on the front of your computer” on page 7.

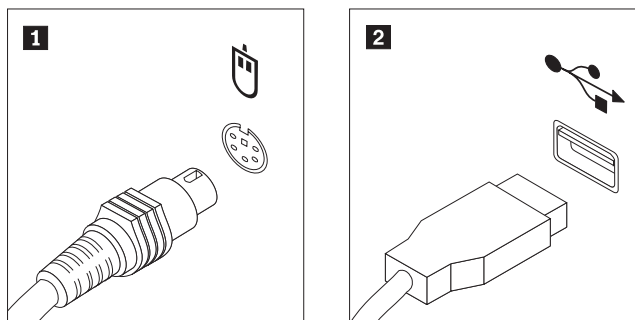

Figure 36. Mouse connectors

4. Disconnect the failing mouse cable from the computer.
5. Connect a new mouse cable to the appropriate connector on the computer.
6. Go to “Completing the parts replacement.”

Completing the parts replacement

After completing all parts replacements, you need to reinstall the computer cover and reconnect cables, including telephone lines and power cords. Depending on the parts replaced, you might need to confirm the updated information in the Setup Utility program. Refer to Chapter 4, “Using the Setup Utility,” on page 51.

To reinstall the computer cover and reconnect cables to your computer:

1. Ensure that all components have been reassembled correctly and no tools or loose screws are left inside your computer.
2. Reposition any cables that might impede the reinstallation of the computer cover.

Important

Correctly route all power supply cables to avoid interference with the drive bay assembly. Keep cables clear of the hinges and sides of the computer chassis.

3. If the drive bay assembly was removed, align it with the two slots and rails on the sides of the chassis and reconnect the drive cables to the system board.
4. Slide the drive bay assembly towards the rear of the chassis until it snaps into position.
5. Reinstall the front bezel if it was removed.
6. Position the computer cover on the chassis so that the rail guides on the sides of the cover engage the rails and push the cover to the closed position until it snaps into position. If your computer has screws that secure the computer cover, install the screws.

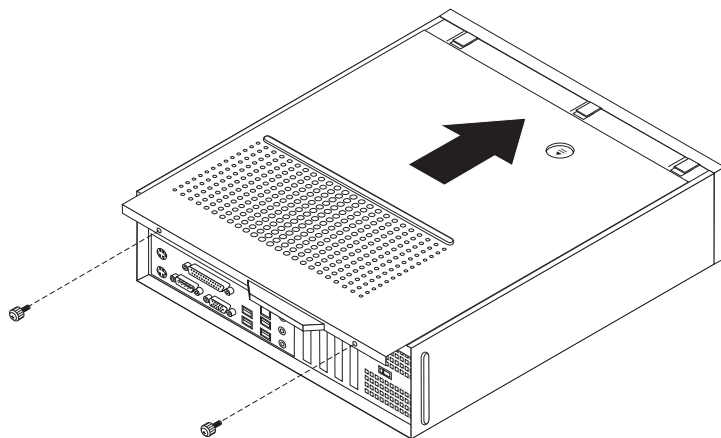

Figure 37. Installing the computer cover

7. Install any locking devices such as a padlock as necessary.
8. Reconnect the external cables and power cords to the computer. See “Locating connectors on the rear of your computer” on page 8.
9. To update your configuration, refer to Chapter 4, “Using the Setup Utility,” on page 51.

Note: In most areas of the world, Lenovo requires the return of the defective CRU. Information about this will come with the CRU or will come a few days after the CRU arrives.

Obtaining device drivers

You can obtain device drivers for operating systems that are not preinstalled at:
<http://www.lenovo.com/support>
Installation instructions are provided in readme files with the device driver files.

Installing security features

To help prevent hardware theft and unauthorized access to your computer, several security options are available. In addition to physical locks, unauthorized use of your computer can be prevented by a software lock that locks the keyboard until a correct password is typed in.

Make sure that any security cables you installed do not interfere with other computer cables.

Integrated cable lock

An integrated cable lock (sometimes referred to as the Kensington lock) can be used to secure your computer to a desk, table, or other non-permanent fixture. The cable lock attaches to a security slot at the rear of your computer and is operated with a key. See Figure 38. The cable lock also locks the buttons used to open the computer cover. This is the same type of lock used with many notebook computers. You can order a security cable directly from Lenovo by searching on *Kensington* at:
<http://www.lenovo.com/support>

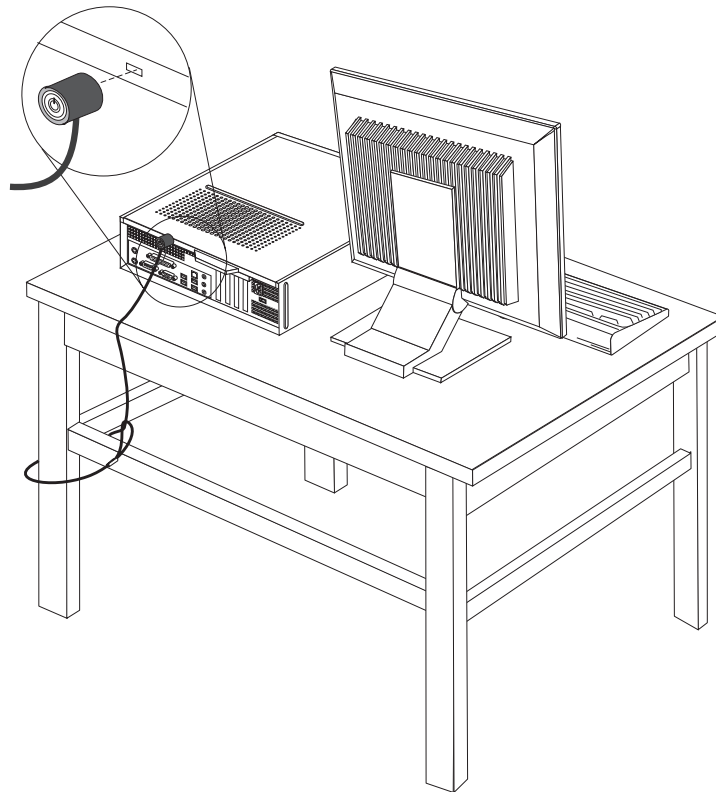

Figure 38. Integrated cable lock

Padlock

Your computer is equipped with a padlock loop so that the computer cover cannot be removed when a padlock is installed.

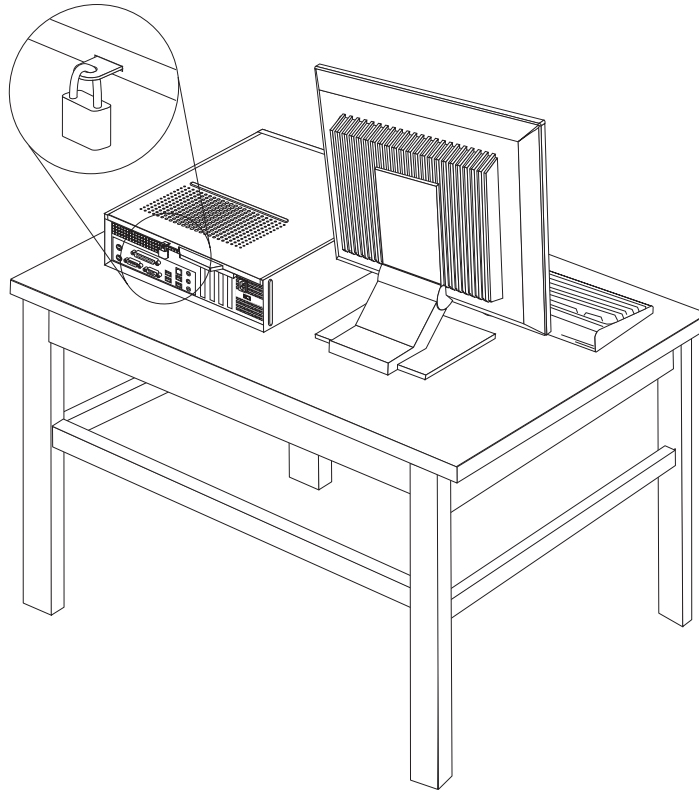

Figure 39. Installing a padlock

Password protection

To deter unauthorized use of your computer, you can use the Setup Utility program to set a password. When you turn on your computer, you are prompted to type the password to unlock the keyboard for normal use. Refer to Chapter 4, “Using the Setup Utility,” on page 51 for more information.

What to do next:

- To work with another option, go to the appropriate section.
- To complete the installation, go to “Completing the parts replacement” on page 37.

Erasing lost or forgotten passwords (clearing CMOS)

This section contains instructions on erasing some lost or forgotten passwords, such as a user password. For more information about lost or forgotten passwords, go to the ThinkVantage Productivity Center program. See “ThinkVantage Productivity Center” on page 65 for more information on how to access the ThinkVantage Productivity Center program.

To erase lost or forgotten passwords:

1. Remove the computer cover. See “Removing the computer cover” on page 14.

2. Locate the Clear CMOS/Recovery jumper on the system board. See “Locating parts on the system board” on page 11.
3. Move the jumper from the standard position (pin 1 and pin 2) to the maintenance or configure position (pin 2 and pin 3).
4. Reinstall the computer cover and connect the power cord. See “Completing the parts replacement” on page 37.
5. Restart the computer, leave it on for approximately 10 seconds. Turn off the computer by holding the power switch for approximately five seconds.
6. Repeat step 1 and step 2 on page 41.
7. Move the Clear CMOS/Recovery jumper back to the standard position (pin 1 and pin 2).
8. Reinstall the computer cover and connect the power cord. See “Completing the parts replacement” on page 37.

Chapter 3. Recovery information

This chapter will help you get familiar with recovery solutions provided by Lenovo. This chapter explains when and how to use the following recovery methods:

- Creating and using Product Recovery discs
- Performing backup and recovery operations
- Using the Rescue and Recovery workspace
- Creating and using rescue media
- Creating and using a Recovery Repair diskette
- Recovering or installing device drivers
- Setting a rescue device in the startup sequence
- Solving recovery problems

Note: There are a variety of methods to choose from when considering how to recover software in the event of a software or hardware-related problem. Some methods vary depending on the type of your operating system.

Creating and using Product Recovery discs

If your computer is equipped with a recordable CD or DVD drive, you can create a set of Product Recovery discs that enable you to restore the contents of the hard disk drive to the factory-installed state. Product Recovery discs are useful if you transfer the computer to another area, sell the computer, recycle the computer, or as a last resort to put the computer in an operational state after all other methods of recovery have failed. As a precautionary measure, it is important to create a set of Product Recovery discs as early as possible.

Note: The recovery operations you can perform using Product Recovery discs vary depending on the operating system from which they were created. Your Microsoft Windows license permits you to create only one set of Product Recovery discs, so it is important that you store the discs in a safe place after you have made them.

To create Product Recovery discs, do the following:

1. From the Windows desktop, click **Start** → **All Programs** → **ThinkVantage** → **Create Recovery Media** or **Create Product Recovery Media**.
2. Follow the instructions on the screen.

The following list explains how Product Recovery discs are used on different operating systems:

- Windows XP: use Product Recovery discs to restore your computer to the factory-installed contents, perform a custom factory recovery, or perform other rescue and recovery operations such as rescuing individual files.
- Windows Vista: use Product Recovery discs to restore your computer to the factory-installed contents only.

When using Product Recovery discs on Windows XP, you are given the option to enter the Rescue and Recovery workspace and choose from a variety of recovery operations. When using Product Recovery discs on Windows Vista, you are

prompted to insert your Product Recovery discs and are guided through the process of restoring to the factory-installed contents only.

To use Product Recovery discs on Windows XP, do the following:

Attention: When you restore the factory-installed contents from the Product Recovery discs, all files currently on the hard disk drive will be deleted and replaced by the factory-installed contents. During the restore process, you will be given the opportunity to save one or more files currently on your hard disk drive to other media before any data is removed.

1. Insert the Start Recovery disc into your optical drive.
2. Restart your computer.
3. After a short delay, the Rescue and Recovery workspace opens.

Note: If the Rescue and Recovery workspace fails to open, you might not have your startup device (CD drive or DVD drive) set correctly in your BIOS startup sequence. For more information, see “Setting a rescue device in the startup sequence” on page 48.

4. In the Rescue and Recovery menu, click **Restore your system**.
5. Follow the instructions on the screen. Insert the appropriate Product Recovery disc when prompted.

To use Product Recovery discs on Windows Vista, do the following:

Attention: When you restore the factory-installed contents from the Product Recovery discs, all files currently on the hard disk drive will be deleted and replaced by the factory contents.

1. Insert the Start Recovery disc into your optical drive.
2. Restart your computer. After a short delay, the Rescue and Recovery workspace opens.

Note: If the Rescue and Recovery workspace fails to open, you might not have your startup device (CD drive or DVD drive) set correctly in your BIOS startup sequence. For more information, see “Setting a rescue device in the startup sequence” on page 48.

3. Follow the instructions on the screen. Insert the appropriate Product Recovery disc when prompted.

Note: After restoring your hard disk drive to the factory-installed contents, you might have to reinstall some software or drivers. See “Using the Rescue and Recovery workspace” on page 45 for details.

Performing backup and recovery operations

The Rescue and Recovery program enables you to back up all your hard disk drive contents including the operating system, data files, application programs, and personal settings. You can designate where the Rescue and Recovery program stores the backup:

- On a protected area of your hard disk drive
- On a second hard disk drive installed in your computer
- On an externally attached USB hard disk drive
- On a network drive

- On recordable CDs or DVDs (a recordable CD or DVD drive is required for this option)

After you have backed up your hard disk drive, you can restore the complete contents of the hard disk drive, restore selected files only, or restore only the Windows operating system and applications.

To perform a backup operation using the Rescue and Recovery program, do the following:

1. From the Windows desktop, click **Start** → **All Programs** → **ThinkVantage** → **Rescue and Recovery**. The Rescue and Recovery program opens.
2. From the Rescue and Recovery main window, click **Back up your hard disk drive** to select backup operation options.
3. Follow the instructions on the screen.

To perform a restore operation using the Rescue and Recovery program, do the following:

1. From the Windows desktop, click **Start** → **All Programs** → **ThinkVantage** → **Rescue and Recovery**. The Rescue and Recovery program opens.
2. From the Rescue and Recovery main window, click the **Restore your system from a backup** icon.
3. Follow the instructions on the screen.

For information about performing a restore operation from the Rescue and Recovery workspace, see “Using the Rescue and Recovery workspace.”

Using the Rescue and Recovery workspace

The Rescue and Recovery workspace resides in a protected, hidden area of your hard disk drive that operates independently from the Windows operating system. This enables you to perform recovery operations even if the Windows operating system cannot be started. You can perform the following recovery operations from the Rescue and Recovery workspace:

- **Rescue files from your hard disk drive or from a backup:** The Rescue and Recovery workspace enables you to locate files on your hard disk drive and transfer them to a network drive or other recordable media, such as a USB hard disk drive or a diskette. This solution is available, even if you did not back up your files or if changes were made to the files since your last backup operation. You can also rescue individual files from a Rescue and Recovery backup located on your local hard disk drive, a USB device, or a network drive.
- **Restore your hard disk drive from a Rescue and Recovery backup:** When you perform a backup operation using the Rescue and Recovery program, you can perform restore operations from the Rescue and Recovery workspace, even if you cannot start the Windows operating system.
- **Restore your hard disk drive to the factory-installed contents:** The Rescue and Recovery workspace enables you to restore the complete contents of your hard disk drive to the factory-installed state. If you have multiple partitions on your hard disk drive, you have the option to restore the factory-installed contents to the C: partition and leave the other partitions intact. Because the Rescue and Recovery workspace operates independently from the Windows operating system, you can restore the factory-installed contents even if you cannot start the Windows operating system.

Attention: If you restore the hard disk drive from a Rescue and Recovery backup or restore the hard disk drive to the factory-installed contents, all files on the primary hard disk drive partition (usually drive C) will be deleted in the recovery process. If possible, make copies of important files. If you are unable to start the Windows operating system, you can use the Rescue files feature in the Rescue and Recovery workspace to copy files from your hard disk drive to other media.

To start the Rescue and Recovery workspace, do the following:

1. Turn off your computer.
2. Restart your computer.
3. Repeatedly press and release the F11 key.
4. When you hear beeps or see a logo screen, release the F11 key.
5. If you set a Rescue and Recovery password, type your password when prompted. The Rescue and Recovery workspace opens after a short delay.

Note: If the Rescue and Recovery workspace fails to open, see “Solving recovery problems” on page 49.

6. Do one of the of the following:
 - To rescue files from your hard disk drive or from a backup, click **Rescue files** and follow the instructions on the screen.
 - To restore your hard disk drive from a Rescue and Recovery backup or to restore your hard disk drive to the factory-installed contents, click **Restore your system** and follow the instructions on the screen.
 - For information about other features of the Rescue and Recovery workspace, click **Help**.

Notes:

1. After restoring a hard disk drive to the factory-installed contents, you might have to reinstall device drivers for some devices. See “Recovering or installing device drivers” on page 48.
2. Some computers come with Microsoft Office or Microsoft Works preinstalled. If you need to recover or reinstall your Microsoft Office or Microsoft Works applications, you must use the *Microsoft Office CD* or *Microsoft Works CD*. These CDs are provided only with computers that come with Microsoft Office or Microsoft Works preinstalled.

Creating and using rescue media

Rescue media such as a disc or a USB hard disk drive enables you to recover from failures that prevent you from gaining access to the Rescue and Recovery workspace on your hard disk drive.

Note: The recovery operations you can perform using rescue media vary depending on the operating system. The rescue disc can be started in any type of CD or DVD drive. Rescue media also contains a PC-Doctor diagnostic program, which enables you to run diagnostics from the rescue media.

To create rescue media, do the following:

1. From the Windows desktop, click **Start** → **All Programs** → **ThinkVantage** → **Create Rescue Media**.

2. In the **Rescue Media** area, select the type of rescue media you want to create. You can create rescue media using a disc, a USB hard disk drive, or a second internal hard disk drive.
3. Click **OK**.
4. Follow the instructions on the screen.

Note: For Windows Vista, use rescue media to restore to the factory-installed contents only.

To use rescue media, do one of the following:

- If your rescue media is on discs, insert the rescue disc and restart your computer.
- If your rescue media is on a USB hard disk drive, attach your USB hard disk drive to one of the USB connectors on your computer, then restart your computer.
- If you are using a second internal hard disk drive, set the startup sequence to start from that drive.

When the rescue media starts, the Rescue and Recovery workspace opens. Help for each feature is available from the Rescue and Recovery workspace. If your rescue media fails to start, you might not have your rescue device (CD drive, DVD drive, or USB device) set correctly in the BIOS startup sequence. For more information, see “Setting a rescue device in the startup sequence” on page 48.

Creating and using a Recovery Repair diskette

If you are unable to access the Rescue and Recovery workspace or the Windows environment, use a Recovery Repair diskette to repair the Rescue and Recovery workspace or repair a file needed to enter the Windows environment. It is important to create a Recovery Repair diskette as soon as possible and store it in a safe place as a precautionary measure.

To create a Recovery Repair diskette, do the following:

1. Start your computer and operating system.
2. Using an Internet browser, go to the following Web address:

<http://www.lenovo.com/think/support/site.wss/document.do?Indocid=MIGR-54483>

3. Insert a diskette into the diskette drive. Information on the diskette will be erased and the diskette will be formatted appropriately.
4. Double-click on the appropriate file name. The diskette is created.
5. Take out the diskette and label it Recovery Repair diskette.

To use the Recovery Repair diskette, do the following:

1. Shut down the operating system and turn off the computer.
2. Insert the Recovery Repair diskette into the diskette drive.
3. Turn on the computer and follow the instructions on the screen.

Note: If the repair operation finishes without error, you will be able to access the Rescue and Recovery workspace by repeatedly pressing the F11 key while you restart your computer. When you hear beeps or see a logo screen, release the F11 key. You will also be able to access the Windows environment after the repair operation finishes.

If an error message appears during the repair operation and the repair operation cannot be completed, you might have a problem with the partition that contains the Rescue and Recovery workspace. Use your rescue media to access the Rescue and Recovery workspace. For information about creating and using rescue media, see "Creating and using rescue media" on page 46.

Recovering or installing device drivers

Before you can recover or install device drivers, make sure your operating system is installed and you have the documentation and software media for the device.

Device drivers for factory-installed devices are located on the computer hard disk drive (usually drive C) in the SWTOOLS\drivers folder. Other device drivers are on the software media that come with individual devices.

The latest device drivers for factory-installed devices also are available at:
<http://www.lenovo.com/think/support>

To reinstall a device driver for a factory-installed device, do the following:

1. Start your computer and operating system.
2. Use Windows Explorer or My Computer to display the directory structure of your hard disk drive.
3. Open the C:\SWTOOLS folder.
4. Open the DRIVERS folder. Within the DRIVERS folder are several subfolders that are named for various devices installed in your computer (for example, AUDIO or VIDEO).
5. Open the appropriate device subfolder.
6. Use one of the following methods to reinstall the device driver:
 - In the device subfolder, look for a README.txt or other file with the .txt extension. This file might be named after the operating system, such as WIN98.txt. The TXT file has information on how to reinstall that device driver.
 - If the device subfolder contains a file with an .INF extension, you can use the Add New Hardware program (located in the Windows Control Panel) to reinstall the device driver. Not all device drivers can be reinstalled using this program. In the Add New Hardware program, when prompted for the device driver that you want to install, click **Have Disk** and **Browse**. Then select the appropriate device driver file from the device subfolder.
 - In the device subfolder, look for a SETUP.EXE file. Double-click **SETUP.EXE** and follow the instructions on the screen.

Setting a rescue device in the startup sequence

Before you start the Rescue and Recovery program from a CD, DVD, USB hard disk drive, or any external device, you must first change the startup sequence in the Setup Utility.

To view or change the startup sequence, do the following:

1. With the computer turned off, repeatedly press and release the F1 key while you turn on the computer.
2. When the logo screen appears, or you hear a series of beeps, release the F1 key.
3. If you are prompted for a password, type your current password.
4. From the Setup Utility main menu, use the right-arrow key to select **Startup**.

5. Arrange the startup sequence to meet your needs.
6. Press the Esc key twice to go to the Setup Utility exit menu.
7. Use the down-arrow key to select **Save and exit the Setup Utility**, then press Enter.
8. When the Setup Confirmation window appears, press Enter.
9. The computer restarts.

Note: If you are using an external device, you first must turn off your computer before connecting the external device.

For more information on Setup Utility, see Chapter 4, “Using the Setup Utility,” on page 51.

Solving recovery problems

If you are unable to access the Rescue and Recovery workspace or the Windows environment, you can:

- Use your rescue media (CD, DVD, or USB hard disk drive) to start the Rescue and Recovery workspace. See “Creating and using rescue media” on page 46 for details.
- Use a Recovery Repair diskette to repair the Rescue and Recovery workspace or repair a file needed to enter the Windows environment. See “Creating and using a Recovery Repair diskette” on page 47 for details.
- Use a set of Product Recovery discs if your intent is to restore the hard disk drive to the factory-installed contents. See “Creating and using Product Recovery discs” on page 43.

It is important to create a Recovery Repair diskette, rescue media, and a set of Product Recovery discs as soon as possible and store them in a safe place.

If you are unable to access the Rescue and Recovery workspace or the Windows environment from rescue media, a Recovery Repair diskette, or a set of Product Recovery discs, you might not have the rescue device, CD drive, DVD drive, or USB hard disk drive defined as a startup device in the BIOS startup sequence. For more information, see “Setting a rescue device in the startup sequence” on page 48.

Chapter 4. Using the Setup Utility

The Setup Utility program is used to view and change the configuration settings of your computer, regardless of which operating system you are using. However, the operating system settings might override any similar settings in the Setup Utility program.

Starting the Setup Utility program

To start the Setup Utility program, do the following:

1. If your computer is already on when you start this procedure, shut down the operating system and turn off the computer.
2. Press and hold the F1 key then turn on the computer.
3. Release the F1 key.

Notes:

- a. If you are using a USB keyboard and the Setup Utility program does not display using this method, repeatedly press and release the F1 key rather than leaving it pressed when turning on the computer.
- b. If a user password or an administrator password has been set, the Setup Utility program menu is not displayed until you type your password. For more information, see "Using passwords."

The Setup Utility program might start automatically when POST detects that hardware has been removed or new hardware has been installed in your computer.

Viewing and changing settings

The Setup Utility program menu lists items that identify system configuration topics. To view or change settings, see "Starting the Setup Utility program."

When working with the Setup Utility program menu, you must use the keyboard. The keys used to perform various tasks are displayed at the bottom of each screen.

Using passwords

By using the Setup Utility program, you can set passwords to prevent unauthorized access to your computer and data. See "Starting the Setup Utility program." The following types of passwords are available:

- User Password
- Administrator Password

You do not have to set any passwords to use your computer. However, if you decide to set any passwords, read the following sections.

Password considerations

A password can be any combination of up to 12 (1 to 12) alphabetic and numeric characters (a-z and 0-9). For security reasons, it is recommended to use a strong password that cannot be easily compromised. A strong password should adhere to the following rules:

- Have at least eight characters in length and contain at least one alphabetic character and one numeric character
- Setup Utility program and hard disk drive passwords are not case sensitive
- Not be your name or your user name
- Not be a common word or a common name
- Be significantly different from your previous password

User Password

When a User Password is set, the computer cannot be used until a valid password is typed in.

Administrator Password

When an Administrator Password is set, it deters unauthorized people from changing configuration settings. If you are responsible for maintaining the settings of several computers, you might want to set an Administrator Password.

After you set an Administrator Password, a password prompt is displayed each time you try to access the Setup Utility program.

If both the user and administrator passwords are set, you can type either password. However, to change any configuration settings, you must use your administrator password.

Setting, changing, and deleting a password

To set, change, or delete a password, do the following:

Note: A password can be any combination of up to 12 (1 to 12) alphabetic and numeric characters. For more information, see "Password considerations."

1. Start the Setup Utility program (see Chapter 4, "Using the Setup Utility," on page 51).
2. From the Setup Utility program menu, select **Security**.
3. Based on your need, select **Set User Passwords** or **Set Administrator Passwords**.
4. Read the information displayed on the right side of the screen.

Enabling or disabling a device

You can enable or disable user access to a device.

SATA 1

When this feature is set to **Disable**, all devices connected to the SATA controller (such as hard disk drives or the CD-ROM drive) are disabled and will not be displayed in the system configuration.

OnBoard Floppy Controller

When this feature is set to **Disable**, the diskette drive cannot be accessed.

To set the SATA 1, do the following:

1. Start the Setup Utility program (see “Starting the Setup Utility program” on page 51).
2. From the Setup Utility program menu, select **Devices** → **SATA Drives Setup** → **SATA 1** and press Enter.
3. Select **32 Bit Data Transfer**.
4. Select the desired settings and press Enter.
5. Return to the Setup Utility program menu and select **Exit** → **Save Changes and Exit**.

Note: If you do not want to save the settings, select **Discard Changes** or **Discard Changes and Exit**.

To set the OnBoard Floppy Controller, do the following:

1. Start the Setup Utility program (see “Starting the Setup Utility program” on page 51).
2. From the Setup Utility program menu, select **Devices** → **Floppy Drive Setup** → **OnBoard Floppy Controller**.
3. Select the desired settings and press Enter.
4. Return to the Setup Utility program menu and select **Exit** → **Save Changes and Exit**.

Note: If you do not want to save the settings, select **Discard Changes** or **Discard Changes and Exit**.

Selecting a startup device

If your computer does not start up from a device such as the CD-ROM, diskette, or hard disk drive as expected, use one of the following procedures to select a startup device.

Selecting a temporary startup device

Use this procedure to start up from any startup device.

Note: Not all CDs, hard disk drives, and diskettes are bootable.

1. Turn off your computer.
2. Press and hold the F12 key, and then turn on the computer. When the Startup Device Menu appears, release the F12 key.

Note: If you are using a USB keyboard and the Startup Device Menu does not display using this method, repeatedly press and release the F12 key rather than leaving it pressed when turning on the computer.

3. Select the desired startup device from the Startup Device Menu and press Enter to begin.

Note: Selecting a startup device from the Startup Device menu does not permanently change the startup sequence.

Selecting or changing the startup device sequence

To view or permanently change the configured startup device sequence, do the following:

1. Start the Setup Utility program (see “Starting the Setup Utility program” on page 51).
2. Select **Startup** and read the information displayed on the right side of the screen.
3. Select the devices for the Primary Boot Sequence, the Automatic Boot Sequence, and the Error Boot Sequence.
4. From the Setup Utility menu, select **Exit** → **Save Changes and Exit**.

If you have changed these settings and want to return to the default settings, select **Load Optimal Defaults** on the Exit menu.

Exiting from the Setup Utility program

After you finish viewing or changing settings, press Esc to return to the Setup Utility program menu (you might have to press Esc several times). If you want to save the new settings, select **Save Changes and Exit**. Otherwise, your changes will not be saved.

Chapter 5. Updating system programs

This chapter contains information about updating POST/BIOS and how to recover from a POST/BIOS update failure.

Using system programs

System programs are the basic layer of software built into your computer. They include the power-on self-test (POST), the basic Input/Output system (BIOS) code, and the Setup Utility program. POST is a set of tests and procedures that are performed each time you turn on your computer. BIOS is a layer of software that translates instructions from other layers of software into electrical signals that the computer hardware can execute. You can use the Setup Utility program to view and change the configuration and setup of your computer.

Your computer system board has a module called electrically erasable programmable read-only memory (EEPROM, also referred to as flash memory). You can easily update POST, BIOS, and the Setup Utility program by starting your computer using a flash update diskette or disc, or by running a special update program from your operating system.

Lenovo might make changes and enhancements to the POST/BIOS. When updates are released, they are available as downloadable files at:

<http://www.lenovo.com>

Instructions for using the POST/BIOS updates are available in a TXT file that is included with the update files. For most models, you can download either an update program to create a system-program-update (flash) diskette or disc, or an update program that can be run from the operating system.

Note: You can download a self-starting bootable CD/DVD image (known as an ISO image) of the diagnostics program to support systems without a diskette drive from:

<http://www.lenovo.com>

Updating (flashing) BIOS from a diskette or disc

This section provides instructions on how to update (flash) BIOS using a diskette or disc. System program updates are available at:

<http://www.lenovo.com/support>

1. To update (flash) BIOS:
 - From a diskette, make sure the computer is turned off and insert a system-program-update (flash) diskette. Then turn on the computer. The update begins.
 - From a disc, make sure the computer is turned on and insert the disc into the optical drive.
2. Turn on the computer. If it is on already, you must turn it off and back on again. The update begins.
3. Select a language when prompted by pressing the number on your keyboard that corresponds to the language and then press Enter.
4. When prompted to change the serial number, press Y.

5. Type in the seven character serial number of your computer and then press Enter.
6. When prompted to change the machine type/model, press Y.
7. Type in the seven character machine type/model of your computer and then press Enter.
8. Follow the instructions on the screen to complete the update.

Updating (flashing) BIOS from your operating system

Note: The Web page content (including the links referenced in the following procedure) is subject to change because of the constant improvements made to the Web site.

1. Go to:
<http://www.lenovo.com/support>
2. Locate the Downloadable files for your machine type as follows:
 - a. In the **Enter a product** field, type your machine type.
 - b. Click **Go** → **Continue** → **Downloads and drivers**.
 - c. Under the BIOS category, click the Flash BIOS update.
 - d. Click the TXT file that contains the installation instructions for the flash BIOS update (flash from the operating system version).
3. Print these instructions. This is very important because they are not on the screen after the download begins.
4. From your browser, click **Back** to return to the list of files. Carefully follow the printed instructions to download, extract, and install the update.

Recovering from a POST/BIOS update failure

If the power to your computer is interrupted while POST/BIOS is being updated (flash update), your computer might not restart correctly. If this happens, perform the following procedure which is commonly called Boot-block recovery.

1. Turn off the computer and any attached devices, such as printers, monitors, and external drives.
2. Unplug all power cords from electrical outlets and remove the computer cover. See “Removing the computer cover” on page 14.
3. Access the system board. See “Accessing the system board components and drives” on page 15.
4. Locate the Clear CMOS/Recovery jumper on the system board. See “Locating parts on the system board” on page 11.
5. Remove any cables that might prevent your access to the Clear CMOS/Recovery jumper.
6. Move the jumper from the standard position (pin 1 and pin 2) to pin 2 and pin 3.
7. Reconnect any cables that were disconnected. See “Completing the parts replacement” on page 37.
8. Reinstall the computer cover and reconnect the power cords for the computer and monitor to electrical outlets.
9. Do one of the following:
 - Insert the POST/BIOS update (flash update) diskette into the diskette drive and turn on the computer and the monitor.

- Turn on the computer and the monitor, and then insert the POST/BIOS update (flash update) disc into the optical drive. Turn the computer off and back on again.
10. The recovery session will take two to three minutes. During this time you will hear a series of beeps. After the update session is completed, there will be no video, the series of beeps will end, and the system will automatically turn off. Immediately remove the disc from the optical drive before the computer completely turns off or remove the diskette from the diskette drive.
 11. Repeat steps 2 through 5.
 12. Move the jumper back to the standard position (pin 1 and pin 2).
 13. Reconnect any cables that were disconnected. See “Completing the parts replacement” on page 37.
 14. Reinstall the computer cover and reconnect the power cords for the computer and monitor to electrical outlets.
 15. Turn on the computer to restart the operating system.

Chapter 6. Troubleshooting and diagnostics

This chapter describes some basic troubleshooting and diagnostic programs. If your computer problem is not described here, see Chapter 7, "Getting information, help, and service," on page 65 for additional troubleshooting resources.

Basic troubleshooting

The following table provides information to help you troubleshoot your computer problem.

Symptom	Action
The computer does not start when you press the power button.	<p>Verify that:</p> <ul style="list-style-type: none">• The power cord is plugged into the rear of the computer and into a working electrical outlet.• If your computer has a secondary power switch on the back of the computer, make sure that it is switched on.• The power indicator on the front of the computer is on.• The voltage is set to the correct setting for your country. <p>If you cannot correct the problem, have the computer serviced. Refer to the safety and warranty information that is provided with your computer for a list of service and support telephone numbers.</p>
The monitor screen is blank.	<p>Verify that:</p> <ul style="list-style-type: none">• The monitor cable is securely attached to the rear of the monitor and to the rear of the computer.• The monitor power cord is plugged into the monitor and into a working electrical outlet.• The monitor is turned on and the brightness and contrast controls are set correctly.• The voltage is set to the correct setting for your country.• The monitor signal cable is securely connected to the monitor and to the monitor connector on the computer. <p>Note: If your computer has two monitor connectors, verify that your monitor is connected to the option connector rather than the one in the rear of the system board. For more information, see "Connecting your computer" in the <i>ThinkCentre Safety and Warranty Guide</i>.</p> <p>If you cannot correct the problem, have the computer serviced. Refer to the safety and warranty information that is provided with your computer for a list of service and support telephone numbers.</p>

Symptom	Action
The keyboard does not work. The computer does not respond to the keyboard.	<p>Verify that:</p> <ul style="list-style-type: none"> • The computer is turned on. • The monitor is turned on and the brightness and contrast controls are set correctly. • The keyboard is securely connected to the keyboard connector on the computer. • No keys are stuck. <p>If you cannot correct the problem, have the computer serviced. Refer to the safety and warranty information that is provided with your computer for a list of service and support telephone numbers.</p>
The USB Keyboard does not work.	<p>Verify that:</p> <ul style="list-style-type: none"> • The computer is turned on. • The keyboard is securely connected to a USB connector on the front or rear of the computer. • No keys are stuck. <p>If you cannot correct the problem, have the computer serviced. Refer to the safety and warranty information that is provided with your computer for a list of service and support telephone numbers.</p>
The mouse does not work. The computer does not respond to the mouse.	<p>Verify that:</p> <ul style="list-style-type: none"> • The computer is turned on. • The mouse is securely connected to the mouse connector on the computer. • The mouse is clean. Refer to “Cleaning the mouse” on page 63 for further information. <p>If you cannot correct the problem, have the computer serviced. Refer to the safety and warranty information that is provided with your computer for a list of service and support telephone numbers.</p>
The operating system will not start.	<p>Verify that:</p> <ul style="list-style-type: none"> • There is no diskette in the diskette drive. • The startup sequence includes the device where the operating system resides. Usually, the operating system is on the hard disk drive. For more information, see “Selecting a startup device” on page 53. <p>If you cannot correct the problem, have the computer serviced. Refer to the safety and warranty information that is provided with your computer for a list of service and support telephone numbers.</p>
The computer beeps multiple times before the operating system starts.	<p>Verify that no keys are stuck down.</p> <p>If you cannot correct the problem, have the computer serviced. Refer to the safety and warranty information that is provided with your computer for a list of service and support telephone numbers.</p>

Diagnostic programs

Diagnostic programs are used to test hardware components of your computer and report operating-system-controlled settings that can cause hardware failures. There are two diagnostic programs preinstalled on your computer:

- Lenovo System Toolbox (used to diagnose problems while running the Windows operating system)
- PC-Doctor for Windows PE (used when your Windows operating system does not start)

Notes:

1. You can also download the latest version of the Lenovo System Toolbox and the PC-Doctor for DOS diagnostic programs from:
<http://www.lenovo.com/support>
See “Lenovo System Toolbox” and “PC-Doctor for DOS” on page 62 for detailed information.
2. If you are unable to isolate and repair the problem yourself after you run the Lenovo System Toolbox and the PC-Doctor for Windows PE, save and print the log files created by both diagnostic programs. You will need the log files when you speak to a Lenovo technical support representative.

Lenovo System Toolbox

The Lenovo System Toolbox is a diagnostic program that works through the Windows operating system and enables you to view symptoms and solutions for computer problems, access the Lenovo troubleshooting center, update system drivers, and review system information.

To run the Lenovo System Toolbox, click **Start** → **All Programs** → **Lenovo Services** → **Lenovo System Toolbox**. Follow the instructions on the screen. For additional information about running the diagnostic program, refer to the Lenovo System Toolbox help system.

If you still suspect a problem after the Lenovo System Toolbox runs successfully, run the PC-Doctor for Windows PE to help you diagnose the computer problem.

The Lenovo System Toolbox also has problem determination aids that determine software and usage problems.

PC-Doctor for Windows PE

The PC-Doctor for Windows PE diagnostic program is part of the Rescue and Recovery workspace on each Lenovo computer. Use the PC-Doctor for Windows PE if you are unable to start the Windows operating system or if the Lenovo System Toolbox has not been successful in isolating a possible problem.

Running diagnostics from the Rescue and Recovery workspace

You can run the PC-Doctor for Windows PE diagnostic program from the Rescue and Recovery workspace. To run diagnostics from the Rescue and Recovery workspace, do the following:

1. Shut down the operating system and turn off the computer.
2. Repeatedly press and release the F11 key when you turn on the computer.
3. When you hear beeps or see a logo screen, stop pressing the F11 key. The Rescue and Recovery workspace opens.
4. From the Rescue and Recovery workspace, select **Launch Advanced Rescue and Recovery** → **Diagnose hardware**.
5. The diagnostic program opens automatically. Select the diagnostic test you want to run. Press the F1 key for additional help.
6. Follow the instructions on the screen.

Note: Rescue media includes the PC-Doctor for Windows PE. For more information about rescue media, see “Creating and using rescue media” on page 46.

PC-Doctor for DOS

You can also download the latest version of the PC-Doctor for DOS diagnostic program from:

<http://www.lenovo.com/support>

The PC-Doctor for DOS diagnostic program is part of the Rescue and Recovery workspace and runs independently of the Windows operating system. Use PC-Doctor for DOS, if you are unable to start the Windows operating system or if the Lenovo System Toolbox and the PC-Doctor for Windows PE have not been successful in isolating a possible problem. You can run the PC-Doctor for DOS from a diagnostic CD/DVD image or diagnostic diskettes that you create. You can also run the PC-Doctor for DOS from the Rescue and Recovery workspace.

Note: It is important to create a diagnostic CD/DVD image or diagnostic diskettes in case PC-Doctor for DOS cannot be run from the Rescue and Recovery workspace.

Creating a diagnostic CD/DVD image

To create a diagnostic CD/DVD image, download a self-starting bootable CD/DVD image (known as an ISO image) of the diagnostic program from

<http://www.lenovo.com/support>

After you download the image, you can create the CD/DVD using any CD/DVD burning software.

Running diagnostics from the disc or diskettes

To run diagnostics from the diagnostic CD/DVD image or diagnostic diskettes that you created, do the following:

1. Make sure the computer is turned off.
2. If you are running diagnostics from diskettes using a USB diskette drive, plug in the USB device.
3. Insert the disc into the optical drive or the first diagnostic diskette into the diskette drive.
4. Restart the computer.

Note: If the diagnostic program does not start, you might not have your optical drive or diskette drive set as a startable device. See “Selecting a startup device” on page 53 for instructions on how to change the startup device.

5. When the diagnostics program opens, follow the instructions on the screen.

Note: If you are running diagnostics from a diskette, when prompted, remove the first diskette and insert the second diskette.

6. When the program finishes, be sure to remove the disc or diskette from the drive.
7. Select the diagnostic test you want to run. Press the F1 key for additional help.

Running diagnostics from the Rescue and Recovery workspace

To run diagnostics from the Rescue and Recovery workspace, do the following:

Note: If you did not create a diagnostic CD/DVD image, you can run the PC-Doctor for DOS diagnostic program from the Rescue and Recovery workspace.

1. Shut down the operating system and turn off the computer.
2. Repeatedly press and release the F11 key when you turn on the computer.

3. When you hear beeps or see a logo screen, stop pressing the F11 key. The Rescue and Recovery workspace opens.

Note: For some models, press the Esc key to enter the Rescue and Recovery.

4. From the Rescue and Recovery workspace, select **Launch Advanced Rescue and Recovery → Diagnose hardware**.
5. Follow the prompts on the screen. The computer will restart.
6. When the computer restarts, the diagnostic program opens automatically. Select the diagnostic test you want to run. Press the F1 key for additional help.

Cleaning the mouse

This section provides instructions on how to clean an optical or non-optical mouse.

Optical mouse

An optical mouse uses a light-emitting diode (LED) and an optical sensor to navigate the pointer. If the pointer on the screen does not move smoothly with the optical mouse, you might need to clean the mouse.

To clean the optical mouse:

1. Turn off your computer.
2. Disconnect the mouse cable from the computer.
3. Turn the mouse upside down to look at the lens.
 - a. If there is a smudge on the lens, gently clean the area with a plain cotton-tipped swab.
 - b. If there is debris in the lens, gently blow the debris away from the area.
4. Check the surface on which you are using the mouse. If you have a very intricate picture or pattern beneath the mouse it may be difficult for the digital signal processor (DSP) to determine changes in the mouse position.
5. Reconnect the mouse cable to the computer.
6. Turn your computer back on.

Non-optical mouse

The non-optical mouse uses a ball to navigate the pointer. If the pointer on the screen does not move smoothly with the mouse, you might need to clean the mouse.

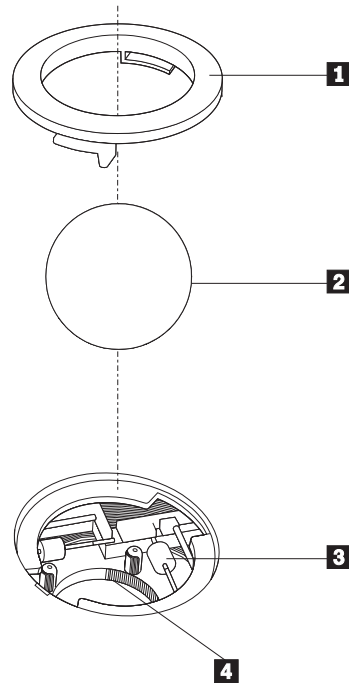

- 1** Retainer ring
- 2** Ball
- 3** Plastic rollers
- 4** Ball cage

To clean the non-optical mouse, do the following:

Note: The following illustration might be slightly different from your mouse.

1. Turn off your computer.
2. Disconnect the mouse cable from the computer.
3. Turn the mouse upside down. Twist the retainer ring **1** to the unlocked position to remove the ball.
4. Place your hand over the retainer ring and ball **2**, and then turn the mouse right-side up, so that the retainer ring and ball fall out into your hand.
5. Wash the ball in warm, soapy water then dry it with a clean cloth.
6. Blow air carefully into the ball cage **4** to dislodge dust and lint.
7. Look for a buildup of dirt on the plastic rollers **3** inside the ball cage. This buildup usually appears as a stripe running across the middle of the rollers.
8. If the rollers are dirty, clean them by using a cotton swab soaked in isopropyl (rubbing) alcohol. Turn the rollers with your finger and continue swabbing them until all the dirt is removed. Be sure the rollers are still centered in their channels after you clean them.
9. Remove any fibers from the swab that might be remaining on the rollers.
10. Replace the ball and the retainer ring. Twist the retainer ring to the locked position.
11. Reconnect the mouse cable to the computer.
12. Turn your computer back on.

Chapter 7. Getting information, help, and service

This chapter contains information about help, service, and technical assistance for products manufactured by Lenovo.

Information resources

This section describes how to access useful resources relating to your computing needs.

Online Books folder

The Online Books folder provides the *ThinkCentre User Guide* to help you set up and use your computer. The Online Books folder is preinstalled on your computer and requires no Internet access to view the publications.

To view a publication, click **Start** → **All Programs** → **Online Books** → **Online Books**. Double-click on the appropriate publication for your computer. The publications also are available on the Lenovo Web site at:
<http://www.lenovo.com>

Notes:

1. These publications are in PDF, which requires the Adobe Reader to be installed to view. If the Adobe Reader has not yet been installed on your computer, a message will appear when you attempt to view the PDF file and you will be guided through the Adobe Reader installation.
2. The publications that are preinstalled on your computer are available in other languages on the Lenovo Support Web site at:
<http://www.lenovo.com/support>
3. If you want to install a different language version of the Adobe Reader rather than the version provided on your computer, download the version you want to use from the Adobe Web site at:
<http://www.adobe.com>

ThinkVantage Productivity Center

The ThinkVantage Productivity Center program contains information sources and tools designed to make computing easier and secure.

The ThinkVantage Productivity Center program provides information about your computer and easy access to various technologies, such as:

- Rescue and Recovery
- Productivity Center
- Client Security Solution
- Factory Recovery
- System Update
- Service and support

Note: ThinkVantage Technologies are only available on select Lenovo computers.

To access the ThinkVantage Productivity Center program, click **Start** → **All Programs** → **ThinkVantage** → **Productivity Center**.

Access Help

The Access Help online help system provides information about getting started, doing basic tasks, customizing settings for your personal preference, protecting data, expanding and upgrading, and troubleshooting.

To open Access Help, open the **Start** menu from the Windows desktop, select **All Programs** → **ThinkVantage** → **Access Help**. After you have opened Access Help, use the left panel to make a selection from the **Contents** tab or the **Index** tab, or use the **Search** tab to find a particular word or phrase.

Safety and Warranty

The safety and warranty information that is provided with your computer contains information on safety, warranty, and notices. Be sure to read and understand all the safety information before using this product.

Lenovo Web site (<http://www.lenovo.com>)

The Lenovo Web site provides up-to-date information and services to help you buy, upgrade, and maintain your computer. You can also do the following:

- Shop for desktop and notebook computers, monitors, projectors, upgrades and accessories for your computer, and special offers.
- Purchase additional services, such as support for hardware, operating systems, application programs, network setup and configuration, and custom installations.
- Purchase upgrades and extended hardware repair services.
- Download the latest device drivers and software updates for your computer model.
- Access the online manuals for your products.
- Access the Lenovo Limited Warranty.
- Access troubleshooting and support information for your computer model and other supported products.
- Find the service and support phone number for your country or region.
- Find a Service Provider located near you.

Help and service

This section contains information about obtaining help and service.

Using the documentation and diagnostic programs

If you experience a problem with your computer, see Chapter 6, “Troubleshooting and diagnostics,” on page 59. For information on additional resources to help you troubleshoot your computer problem, see “Information resources” on page 65.

If you suspect a software problem, see the documentation, including readme files and online help, that comes with the operating system or application program.

Most computers come with a set of diagnostic programs that you can use to help you identify hardware problems. For instructions on using the diagnostic programs, see “Diagnostic programs” on page 60.

Lenovo maintains pages on the World Wide Web where you can get the latest technical information and download device drivers and updates. To access these pages, follow the instructions at:
<http://www.lenovo.com/support>

Calling for service

During the warranty period, you can get help and information by telephone through the Customer Support Center.

These services are available during the warranty period:

- **Problem determination** - Trained personnel are available to assist you with determining a hardware problem and deciding what action is necessary to fix the problem.
- **Hardware repair** - If the problem is caused by hardware under warranty, trained service personnel are available to provide the applicable level of service.
- **Engineering Change management** - There might be changes that are required after a product has been sold. Lenovo or your reseller will make selected Engineering Changes (ECs) that apply to your hardware available.

The following items are not covered by the warranty:

- Replacement or use of parts not manufactured for or by Lenovo or non-warranted Lenovo parts
- Identification of software problem sources
- Configuration of BIOS as part of an installation or upgrade
- Changes, modifications, or upgrades to device drivers
- Installation and maintenance of network operating systems (NOS)
- Installation and maintenance of application programs

Refer to the safety and warranty information that is provided with your computer for a complete explanation of warranty terms. You must retain your proof of purchase to obtain warranty service.

For a list of service and support phone numbers for your country or region, go to <http://www.lenovo.com/support> and click **Support phone list** or refer to the safety and warranty information provided with your computer.

Note: Phone numbers are subject to change without notice. If the number for your country or region is not provided, contact your Lenovo reseller or Lenovo marketing representative.

If possible, be at your computer when you call. Have the following information available:

- Machine type and model
- Serial numbers of your hardware products
- Description of the problem
- Exact wording of any error messages
- Hardware and software configuration information

Using other services

If you travel with your computer or relocate it to a country where your desktop or notebook computer machine type is sold, your computer might be eligible for International Warranty Service, which automatically entitles you to obtain warranty service throughout the warranty period. Service will be performed by service providers authorized to perform warranty service.

Service methods and procedures vary by country, and some services might not be available in all countries. International Warranty Service is delivered through the method of service (such as depot, carry-in, or on-site service) that is provided in the servicing country. Service centers in certain countries might not be able to service all models of a particular machine type. In some countries, fees and restrictions might apply at the time of service.

To determine whether your computer is eligible for International Warranty Service and to view a list of the countries where service is available, go to <http://www.lenovo.com/support>, click **Warranty**, and follow the instructions on the screen.

For technical assistance with the installation of or questions related to Service Packs for your preinstalled Microsoft Windows product, refer to the Microsoft Product Support Services Web site at <http://support.microsoft.com/directory/>, or you can contact the Customer Support Center. Some fees might apply.

Purchasing additional services

During and after the warranty period, you can purchase additional services, such as support for hardware, operating systems, and application programs; network setup and configuration; upgraded or extended hardware repair services; and custom installations. Service availability and service name might vary by country or region. For more information about these services, go to: <http://www.lenovo.com>

Appendix. Notices

Lenovo may not offer the products, services, or features discussed in this document in all countries. Consult your local Lenovo representative for information on the products and services currently available in your area. Any reference to a Lenovo product, program, or service is not intended to state or imply that only that Lenovo product, program, or service may be used. Any functionally equivalent product, program, or service that does not infringe any Lenovo intellectual property right may be used instead. However, it is the user's responsibility to evaluate and verify the operation of any other product, program, or service.

Lenovo may have patents or pending patent applications covering subject matter described in this document. The furnishing of this document does not give you any license to these patents. You can send license inquiries, in writing, to:

*Lenovo (United States), Inc.
1009 Think Place - Building One
Morrisville, NC 27560
U.S.A.
Attention: Lenovo Director of Licensing*

LENOVO PROVIDES THIS PUBLICATION "AS IS" WITHOUT WARRANTY OF ANY KIND, EITHER EXPRESS OR IMPLIED, INCLUDING, BUT NOT LIMITED TO, THE IMPLIED WARRANTIES OF NON-INFRINGEMENT, MERCHANTABILITY OR FITNESS FOR A PARTICULAR PURPOSE. Some jurisdictions do not allow disclaimer of express or implied warranties in certain transactions, therefore, this statement may not apply to you.

This information could include technical inaccuracies or typographical errors. Changes are periodically made to the information herein; these changes will be incorporated in new editions of the publication. Lenovo may make improvements and/or changes in the product(s) and/or the program(s) described in this publication at any time without notice.

The products described in this document are not intended for use in implantation or other life support applications where malfunction may result in injury or death to persons. The information contained in this document does not affect or change Lenovo product specifications or warranties. Nothing in this document shall operate as an express or implied license or indemnity under the intellectual property rights of Lenovo or third parties. All information contained in this document was obtained in specific environments and is presented as an illustration. The result obtained in other operating environments may vary.

Lenovo may use or distribute any of the information you supply in any way it believes appropriate without incurring any obligation to you.

Any references in this publication to non-Lenovo Web sites are provided for convenience only and do not in any manner serve as an endorsement of those Web sites. The materials at those Web sites are not part of the materials for this Lenovo product, and use of those Web sites is at your own risk.

Any performance data contained herein was determined in a controlled environment. Therefore, the result obtained in other operating environments may

vary significantly. Some measurements may have been made on development-level systems and there is no guarantee that these measurements will be the same on generally available systems. Furthermore, some measurements may have been estimated through extrapolation. Actual results may vary. Users of this document should verify the applicable data for their specific environment.

Television output notice

The following notice applies to models that have the factory-installed television-output feature.

This product incorporates copyright protection technology that is protected by method claims of certain U.S. patents and other intellectual property rights owned by Macrovision Corporation and other rights owners. Use of this copyright protection technology must be authorized by Macrovision Corporation, and is intended for home and other limited viewing uses only unless otherwise authorized by Macrovision Corporation. Reverse engineering or disassembly is prohibited.

Trademarks

The following terms are trademarks of Lenovo in the United States, other countries, or both:

- Lenovo
- Rescue and Recovery
- The Lenovo logo
- ThinkCentre
- ThinkVantage

Wake on LAN is a trademark of International Business Machines Corporation in the United States, other countries, or both.

Microsoft, Windows, and Windows Vista are trademarks of the Microsoft group of companies.

AMD, AMD Athlon, AMD Phenom, AMD Sempron, and combinations thereof are trademarks of Advanced Micro Devices, Inc.

Linux is a trademark of Linus Torvalds in the United States, other countries, or both.

Other company, product, or service names may be trademarks or service marks of others.

Index

A

- access help 66
- adapter card 19
 - installing, replacing 19
- administrator, password 52
- antivirus software 6
- audio line-in connector 9
- audio line-out connector 9
- audio subsystem 1

B

- backup and recovery operations 44
- basic troubleshooting 59
- battery, replacing 30
- bay 1, installing 24
- bay 3, installing 25
- BIOS, updating (flashing) 55, 56
- books folder, online 65
- Boot-block recovery 56

C

- cable lock, security 39
- changing
 - password 52
 - startup device sequence 54
- cleaning the mouse 63
- CMOS, clearing 40
- components, accessing system board 15
- components, internal 10
- computer cover, reinstalling 37
- connector description 9
- connectors
 - front 7
 - rear 8
- considerations, password 52
- cover
 - removing 14
- creating
 - and using a Recovery Repair diskette 47
 - and using rescue media 46
- creating and using
 - Product Recovery discs 43
- CRU
 - completing the installation 37
- customer support center 67

D

- deleting password 52
- device drivers 38
 - installing 48
 - recovering 48
- devices, handling static-sensitive 13
- diagnostics
 - Rescue and Recovery workspace 62
- diagnostics programs, using 67
- diagnostics, troubleshooting 59

- discs, creating and using Product Recovery discs 43
- diskette drive or card reader, replacing 29
- diskette, creating and using a Recovery Repair 47
- documentation, using 67
- drivers, device 38
- drives
 - bays 23
 - internal 22
 - specifications 23
- DVI monitor connector 9

E

- enabling, disabling
 - device 52
- environment, operating 4
- Ethernet 2
- Ethernet connector 9
- exiting, Setup Utility 54
- expansion adapters 2
- external options, installing 14

F

- failure, recovering from POST/BIOS 56
- features 1
- flashing BIOS 55
- folder, books online 65
- front connectors 7

G

- getting
 - help 65
 - information 65
 - service 65

H

- hard disk drive, replacing 26
- heat sink and fan assembly, replacing 32
- help
 - access 66
 - and service 67
 - getting 65

I

- important safety information v
- information
 - getting 65
 - important safety v
 - resources 65
 - safety 66
 - warranty 66
- Input/Output (I/O) features 2
- installing
 - device drivers 48
- installing drive 24

- installing options
 - adapter card 19
 - internal drives 22
 - memory module 17
 - security features 38
- installing, diskette drive 25
- internal drives 1
- internal speaker, replacing 34

K

- keyboard connector 9
- keyboard, replacing 36

L

- Lenovo System Toolbox 61
- locating components 10

M

- media, creating and using rescue 46
- memory module
 - installing, replacing 17
 - system board 17
- Microphone connector 9
- mouse
 - cleaning 63
 - non-optical 63
 - optical mouse 63
- mouse connector 9
- mouse, replacing 37

N

- non-optical mouse 63
- notice, television output 70
- notices 69

O

- Online Books folder 65
- operations, backup and recovery 44
- optical drive, replacing 28
- optical mouse 63
- options, installing internal drives 22

P

- padlock 40
- parallel port 9
- parts replacement, completing 37
- password
 - administrator 52
 - considerations 52
 - setting, changing, deleting 52
 - user 52
- password protection 40
- passwords
 - erasing 40
 - lost or forgotten 40
- passwords, using 51
- physical specifications 4

- power
 - Advanced Configuration and Power Interface (ACPI)
 - support 2
 - features 2
- power-on self-test (POST) 55
- Product Recovery discs, creating and using 43
- Productivity Center, ThinkVantage 65
- programs, updating system 55
- protection, password 40
- purchasing additional services 68

R

- rear connectors 8
- recovering
 - device drivers 48
 - from a POST/BIOS update failure 56
 - software 43
- recovery
 - Boot-block 56
 - operations, backup and 44
 - problems, solving 49
 - Recovery Repair diskette, creating and using 47
- removing cover 14
- replacing
 - battery 30
 - hard disk drive 26
 - heat sink and fan assembly 32
 - internal speaker 34
 - system fan assembly 33
- Rescue and Recovery 43
 - workspace, Rescue and Recovery 45
- Rescue and Recovery workspace 45
- rescue device, starting 48
- rescue media, creating and using 46
- resources, information 65

S

- safety v
- safety information 66
- security
 - cable lock 39
 - features 3, 38
 - padlock 40
- selecting
 - start up device 53
 - temporary startup device 53
- serial port 9
- service
 - and help 67
 - customer support center 67
 - getting 65
- services
 - other 68
 - purchasing additional 68
- setting
 - password 52
 - rescue device 48
- settings
 - changing 51
 - viewing 51
- Setup Utility 51
- Setup Utility program, starting 51
- Setup Utility, exiting 54

- software
 - recovering 43
- software overview 5
- solving recovery problems 49
- starting the Setup Utility program 51
- startup device 53
 - sequence, changing 54
 - temporary, selecting 53
- static-sensitive devices, handling 13
- system
 - management 2
 - programs 55
- system board
 - components, accessing 15
 - connectors 11
 - locating parts 11
 - location 11
 - memory module 17
- system fan assembly, replacing 33

T

- television output notice 70
- temporary startup device 53
- ThinkVantage Productivity Center 65
- trademarks 70
- troubleshooting, basic 59
- troubleshooting, diagnostics 59

U

- updating
 - (flashing) BIOS 55
 - system programs 55
- updating (flashing) BIOS 56
- USB connector 9
- user, password 52
- using
 - diagnostic programs 67
 - documentation 67
 - other services 68
 - passwords 51
 - Recovery Repair diskette, creating and using 47
 - rescue media, creating and 46
 - Setup Utility 51

V

- VGA monitor connector 9
- video subsystem 1
- viewing and changing settings 51

W

- warranty information 66
- workspace, backup and recovery 45

lenovo®

Part Number: 53Y6559

Printed in USA

(1P) P/N: 53Y6559

