

# USER'S GUIDE

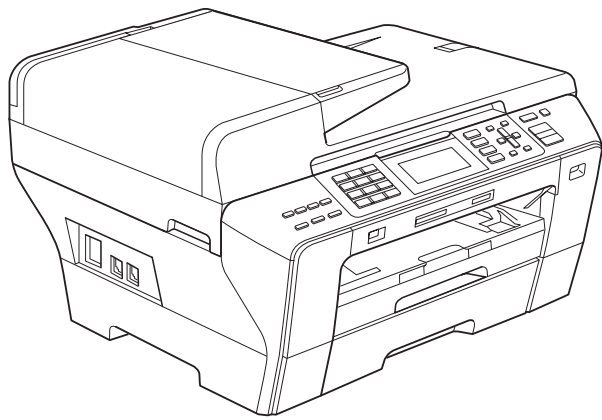

MFC-5890CN  
MFC-6490CW

## **If you need to call Customer Service**

**Please complete the following information for future reference:**

**Model Number: MFC-5890CN and MFC-6490CW (Circle your model number)**

**Serial Number: <sup>1</sup> \_\_\_\_\_**

**Date of Purchase: \_\_\_\_\_**

**Place of Purchase: \_\_\_\_\_**

**<sup>1</sup> The serial number is on the back of the unit. Retain this User's Guide with your sales receipt as a permanent record of your purchase, in the event of theft, fire or warranty service.**

**Register your product on-line at**

**<http://www.brother.com/registration/>**

By registering your product with Brother, you will be recorded as the original owner of the product. Your registration with Brother:

- may serve as confirmation of the purchase date of your product should you lose your receipt; and
- may support an insurance claim by you in the event of product loss covered by insurance.

# Approval Information and Compilation and Publication Notice

THIS EQUIPMENT IS DESIGNED TO WORK WITH A TWO WIRE ANALOGUE PSTN LINE FITTED WITH THE APPROPRIATE CONNECTOR.

## APPROVAL INFORMATION

---

Brother advises that this product may not function correctly in a country other than where it was originally purchased, and does not offer any warranty in the event that this product is used on public telecommunication lines in another country.

## Compilation and Publication Notice

---

Under the supervision of Brother Industries Ltd., this manual has been compiled and published, covering the latest product descriptions and specifications.

The contents of this manual and the specifications of this product are subject to change without notice.

Brother reserves the right to make changes without notice in the specifications and materials contained herein and shall not be responsible for any damages (including consequential) caused by reliance on the materials presented, including but not limited to typographical and other errors relating to the publication.

# EC Declaration of Conformity under the R & TTE Directive



## EC Declaration of Conformity

### Manufacturer

Brother Industries, Ltd.  
15-1, Naeshiro-cho, Mizuho-ku, Nagoya 467-8561, Japan

### Plant

Brother Industries (Shen Zhen) Ltd  
G02414-1, Bao Chang Li Bonded Transportation Industrial Park,  
Bao Long Industrial Estate, Longgang, Shenzhen, China

Herewith declare that:

Products description : Facsimile Machine  
Model Name : MFC-6490CW, MFC-5890CN

are in conformity with provisions of the R & TTE Directive (1999/5/EC) and we declare compliance with the following standards :

Standards applied :

Harmonized : Safety EN60950-1:2001+A11:2004

EMC EN55022: 2006 Class B  
EN55024: 1998 +A1: 2001 +A2: 2003  
EN61000-3-2: 2006  
EN61000-3-3: 1995 +A1: 2001 +A2:2005

Radio EN301 489-1 V1.6.1  
EN301 489-17 V1.2.1  
EN300 328 V1.7.1

※ Radio applies to MFC-6490CW only.

Year in which CE marking was first affixed : 2008

Issued by : Brother Industries, Ltd.

Date : 16th April, 2008

Place : Nagoya, Japan

Signature :

Junji Shiota  
General Manager  
Quality Management Dept.  
Printing & Solutions Company

# Table of Contents

## Section I General

<b>1</b>	<b>General Information</b>	<b>2</b>
	Using the documentation .....	2
	Symbols and conventions used in the documentation .....	2
	Accessing the Software User's Guide and Network User's Guide .....	3
	Viewing Documentation .....	3
	Accessing Brother Support (For Windows®) .....	5
	MFC-6490CW Control panel overview .....	6
	LCD screen indications .....	8
	Basic Operations .....	8
<b>2</b>	<b>Loading paper and documents</b>	<b>9</b>
	Loading paper and other print media .....	9
	Loading paper in paper tray #1 .....	9
	Loading paper in paper tray #2 (MFC-6490CW only) .....	12
	Loading envelopes and postcards .....	15
	Removing small printouts from the machine .....	16
	Printable area .....	17
	Acceptable paper and other print media .....	18
	Recommended print media .....	18
	Handling and using print media .....	19
	Choosing the right print media .....	20
	Loading documents .....	22
	Using the ADF .....	22
	Using the scanner glass .....	23
	Scannable area .....	24
<b>3</b>	<b>General setup</b>	<b>25</b>
	Power Save mode .....	25
	Putting your machine in Power Save mode .....	25
	Bringing your machine out of Power Save mode .....	25
	Power Save setting .....	25
	Mode Timer .....	26
	Paper settings .....	26
	Paper Size and Type (MFC-5890CN only) .....	26
	Paper Size and Type (MFC-6490CW only) .....	27
	Tray use in Copy mode (MFC-6490CW only) .....	28
	Tray use in Fax mode (MFC-6490CW only) .....	28
	Secure Paper Feed mode for A3 size Short Grain Paper .....	29
	Volume Settings .....	29
	Ring Volume .....	29
	Beeper Volume .....	30
	Speaker Volume .....	30
	Automatic Daylight Savings Time .....	30

Sleep Mode.....	31
LCD screen.....	31
LCD Contrast.....	31
Setting the backlight brightness.....	31
Setting the Dim Timer for the backlight .....	32
Setting the Wallpaper .....	32

## **4 Security features 33**

---

Secure Function Lock .....	33
Setting and changing the Administrator Password .....	33
Setting up and changing the Public user .....	34
Setting up and changing restricted users .....	35
Turning Secure Function Lock on/off.....	36
Switching users .....	37
Changing to the Public mode .....	37
Reset all users.....	37

## **Section II Fax**

### **5 Sending a Fax 40**

---

Entering Fax mode .....	40
Faxing from the ADF .....	40
Faxing from the scanner glass .....	41
Setting scanner glass size for faxing (MFC-5890CN only).....	41
Setting scanner glass size for faxing (MFC-6490CW only) .....	42
Colour fax transmission .....	42
How to preview an outgoing fax .....	42
Cancelling a fax in progress .....	42
Broadcasting (Monochrome only).....	43
Cancelling a Broadcast in progress.....	44
Additional sending operations.....	44
Sending faxes using multiple settings .....	44
Contrast .....	45
Changing fax resolution.....	45
Dual access (Monochrome only) .....	46
Real time transmission .....	46
Overseas Mode .....	46
Delayed Faxing (Monochrome only).....	46
Delayed Batch Transmission (Monochrome only) .....	47
Checking and cancelling waiting jobs .....	47
Setting your changes as a new default.....	47
Restoring all settings to the factory settings .....	47
Sending a fax manually .....	48
Out of Memory message .....	48

Receive modes .....	49
Choose the Receive Mode .....	49
Using receive modes .....	50
Fax only .....	50
Fax/Tel.....	50
Manual.....	50
External TAD .....	50
Receive mode settings .....	51
Ring Delay .....	51
F/T Ring Time (Fax/Tel mode only).....	51
Fax Detect .....	52
Additional receiving operations.....	52
Printing a reduced incoming fax .....	52
Setting Receiving Priority .....	53
Printing a fax from the memory .....	54
Out of Paper Reception .....	54
Memory Receive (Monochrome only).....	54
Fax Forwarding.....	55
Fax Storage .....	55
PC Fax Receive.....	56
Changing the destination PC.....	57
Turning off Memory Receive Operations.....	57
Changing Memory Receive Operations.....	58
Fax Preview (Monochrome only).....	58
How to preview a received fax.....	58
Changing the settings to turn off Fax Preview.....	60
Remote Retrieval.....	60
Setting a Remote Access Code.....	60
Using your Remote Access Code.....	61
Remote Fax commands .....	62
Retrieving fax messages .....	63
Changing your Fax Forwarding number .....	63

---

## **7 Telephone and External devices 64**

---

Voice operations .....	64
Tone or Pulse .....	64
Fax/Tel mode .....	64
Fax/Tel mode in Power Save condition .....	64
Telephone services.....	65
Caller ID (U.K. and Ireland only).....	65
Setting the Telephone Line Type.....	66
BT Call Sign (U.K. only).....	66
Connecting an external TAD (telephone answering device).....	67
Connections.....	68
Recording outgoing message (OGM) on an external TAD .....	68
Multi-line connections (PBX) .....	68
External and extension telephones.....	69
Connecting an external or extension telephone .....	69
Operation from extension telephones.....	69
Using extension telephones (For U.K. only) .....	69
Using a cordless external telephone .....	70
Using remote codes.....	70

---

## **8 Dialling and storing numbers 72**

---

How to Dial .....	72
Manual dialling.....	72
One Touch Dialling .....	72
Speed Dialling .....	72
Search .....	73
Fax Redial .....	73
Outgoing Call history .....	73
Caller ID history .....	74
Storing numbers .....	74
Storing a pause .....	74
Storing One Touch Dial numbers .....	74
Storing Speed Dial numbers.....	76
Changing One Touch or Speed Dial names or numbers.....	78
Setting up groups for broadcasting.....	79
Combining Quick Dial numbers .....	80

---

## **9 Printing Reports 82**

---

Fax reports.....	82
Transmission Verification Report.....	82
Fax Journal (activity report) .....	83
Reports .....	83
How to print a report .....	83

**10 Polling 84**

---

Polling overview..... 84  
Polling receive ..... 84  
    Setup to receive polling ..... 84  
    Setup to receive polling with secure code ..... 84  
    Setup to receive delayed polling..... 84  
    Sequential polling (Monochrome only) ..... 85  
Polled transmit (Monochrome only)..... 86  
    Setup for polled transmit..... 86  
    Setup for polled transmit with secure code..... 86

## **Section III Copy**

**11 Making copies 88**

---

How to copy ..... 88  
    Entering Copy mode..... 88  
    Making a single copy ..... 88  
    Making multiple copies ..... 88  
    Stop copying..... 88  
Copy settings ..... 89  
    Changing copy speed and quality ..... 89  
    Enlarging or reducing the image copied ..... 89  
    Making N in 1 copies or a poster (Page Layout) ..... 90  
    Sorting copies using the ADF ..... 92  
    Adjusting Brightness and Contrast ..... 92  
    Paper Options..... 93  
    Skew Adjustment (MFC-6490CW only) ..... 94  
    Book Copy ..... 94  
    Watermark Copy..... 95  
    Setting your changes as a new default..... 96  
    Restoring all settings to the factory settings ..... 96  
'Out of Memory' message..... 97

# Section IV Direct Photo Printing

<b>12</b>	<b>Printing photos from a memory card or USB Flash memory drive</b>	<b>100</b>
	PhotoCapture Center™ Operations.....	100
	Printing from a memory card or USB Flash memory drive without a PC.....	100
	Scanning to a memory card or USB Flash memory drive without a PC.....	100
	Using PhotoCapture Center™ from your computer.....	100
	Using a memory card or USB Flash memory drive.....	100
	Memory cards or a USB Flash memory drive folder structure.....	101
	Getting started.....	102
	Entering PhotoCapture mode.....	103
	Print Images.....	103
	View Photo(s).....	103
	Print Index (Thumbnails).....	104
	Printing Photos.....	105
	Enhance Photos.....	105
	Search by Date.....	108
	Print All Photos.....	108
	Slide show.....	108
	Trimming.....	109
	DPOF printing.....	109
	PhotoCapture Center™ print settings.....	110
	Print Speed and Quality.....	111
	Paper options.....	111
	Adjusting Brightness, Contrast and Colour.....	112
	Cropping.....	113
	Borderless printing.....	113
	Date Print.....	113
	Setting your changes as a new default.....	114
	Restoring all settings to the factory settings.....	114
	Scan to a memory card or USB Flash memory drive.....	114
	Entering Scan mode.....	114
	How to scan to a memory card or USB Flash memory drive.....	114
	Glass Scan Size (MFC-6490CW only).....	116
	How to change the file name.....	116
	How to set a new default.....	116
	How to reset to factory settings.....	116
	Understanding the Error Messages.....	117
<b>13</b>	<b>Printing photos from a camera</b>	<b>118</b>
	Printing photos directly from a PictBridge camera.....	118
	PictBridge requirements.....	118
	Setting your digital camera.....	118
	Printing Images.....	119
	DPOF printing.....	119
	Printing photos directly from a digital camera (without PictBridge).....	120
	Printing Images.....	120
	Understanding the Error Messages.....	121

## Section V Software

<b>14</b>	<b>Software and Network features</b>	<b>124</b>
-----------	--------------------------------------	------------

---

## Section VI Appendixes

<b>A</b>	<b>Safety and Legal</b>	<b>126</b>
----------	-------------------------	------------

---

Choosing a location .....	126
To use the machine safely.....	127
Important safety instructions.....	131
IMPORTANT - For your safety .....	132
LAN connection .....	133
Radio interference .....	133
EU Directive 2002/96/EC and EN50419.....	133
International ENERGY STAR® Compliance Statement .....	133
Legal limitations for copying .....	134
Trademarks.....	135

<b>B</b>	<b>Troubleshooting and Routine Maintenance</b>	<b>136</b>
----------	--	------------

---

Troubleshooting .....	136
If you are having difficulty with your machine .....	136
Dial Tone detection.....	143
Telephone line interference .....	143
Error and Maintenance messages.....	144
Error animations Display .....	150
Transferring your faxes or Fax Journal report .....	150
Document jam .....	151
Printer jam or paper jam (MFC-5890CN only).....	152
Printer jam or paper jam (MFC-6490CW only) .....	154
Routine maintenance.....	157
Replacing the ink cartridges .....	157
Cleaning the outside of the machine .....	160
Cleaning the scanner glass .....	161
Cleaning the machine printer platen.....	161
Cleaning the paper pick-up roller.....	162
Cleaning the print head .....	162
Checking the print quality .....	163
Checking the print alignment.....	164
Checking the ink volume .....	165
Machine Information .....	165
Checking the serial number.....	165
Packing and shipping the machine.....	165

<b>C</b>	<b>Menu and Features</b>	<b>168</b>
	On-screen programming .....	168
	Menu table .....	168
	Memory storage .....	168
	Mode and menu keys .....	168
	Menu table .....	169
	Entering Text .....	194
<b>D</b>	<b>Specifications</b>	<b>195</b>
	General .....	195
	Print media .....	197
	Fax .....	198
	Copy .....	200
	PhotoCapture Center™ .....	201
	PictBridge .....	202
	Scanner .....	203
	Printer .....	204
	Interfaces .....	205
	Computer requirements .....	206
	Consumable items .....	207
	Network (LAN) .....	208
	Wireless one-push configuration .....	209
<b>E</b>	<b>Glossary</b>	<b>210</b>
<b>F</b>	<b>Index</b>	<b>214</b>



# General

---

<b>General Information</b>	<b>2</b>
<b>Loading paper and documents</b>	<b>9</b>
<b>General setup</b>	<b>25</b>
<b>Security features</b>	<b>33</b>

## Using the documentation

Thank you for buying a Brother machine! Reading the documentation will help you make the most of your machine.

## Symbols and conventions used in the documentation

---

The following symbols and conventions are used throughout the documentation.

<b>Bold</b>	Bold typeface identifies specific buttons on the machine's control panel, or on the computer screen.
<i>Italics</i>	Italicized typeface emphasizes an important point or refers you to a related topic.
Courier New	Text in Courier New font identifies messages on the LCD of the machine.



Warnings tell you what to do to prevent possible personal injury.



Cautions specify procedures you must follow or avoid to prevent possible damage to the machine or other objects.



Electrical Hazard icons alert you to possible electrical shock.



Notes tell you how you should respond to a situation that may arise or give tips about how the operation works with other features.



Improper Setup icons alert you to devices and operations that are not compatible with the machine.

# Accessing the Software User's Guide and Network User's Guide

This User's Guide does not contain all the information about the machine such as how to use the advanced features of the Printer, Scanner, PC Fax and Network. When you are ready to learn detailed information about these operations, read the **Software User's Guide** and **Network User's Guide** that are on the CD-ROM.

## Viewing Documentation

### Viewing Documentation (For Windows®)

To view the documentation, from the **Start** menu, point to **Brother, MFC-XXXX** (where XXXX is your model name) from the programs group, and then choose **User's Guides in HTML format**.

If you have not installed the software, you can find the documentation by following the instructions below:

- 1 Turn on your PC. Insert the Brother CD-ROM into your CD-ROM drive.
- 2 If the model name screen appears, click your model name.

- 3 If the language screen appears, click your language. The CD-ROM Main Menu will appear.



### Note

If this window does not appear, use Windows® Explorer to run the start.exe program from the root directory of the Brother CD-ROM.

- 4 Click **Documentation**.
- 5 Click the documentation you want to read.
  - **HTML documents: Software User's Guide and Network User's Guide** in HTML format.  
This format is recommended for viewing on your computer.
  - **PDF documents: User's Guide for stand-alone operations, Software User's Guide and Network User's Guide** in PDF format.  
This format is recommended for printing the manuals. Click to go to the Brother Solutions Center, where you can view or download the PDF documents. (Internet access and PDF Reader software are required.)

## How to find Scanning instructions

There are several ways you can scan documents. You can find the instructions as follows:

### Software User's Guide

- *Scanning* (For Windows® 2000 Professional/Windows® XP and Windows Vista®)
- *ControlCenter3* (For Windows® 2000 Professional/Windows® XP and Windows Vista®)
- *Network Scanning*

### ScanSoft™ PaperPort™ 11SE with OCR How-to-Guides

- The complete ScanSoft™ PaperPort™ 11SE with OCR How-to-Guides can be viewed from the Help selection in the ScanSoft™ PaperPort™ 11SE application.

## How to find Network setup instructions (MFC-6490CW only)

Your machine can be connected to a wireless or wired network. You can find basic setup instructions in the Quick Setup Guide. If your wireless access point supports SecureEasySetup™, Wi-Fi Protected Setup™ or AOSS™, follow the steps in the Quick Setup Guide. For more information about network setup please see the Network User's Guide.

## Viewing Documentation (For Macintosh®)

- 1 Turn on your Macintosh®. Insert the Brother CD-ROM into your CD-ROM drive. The following window will appear.

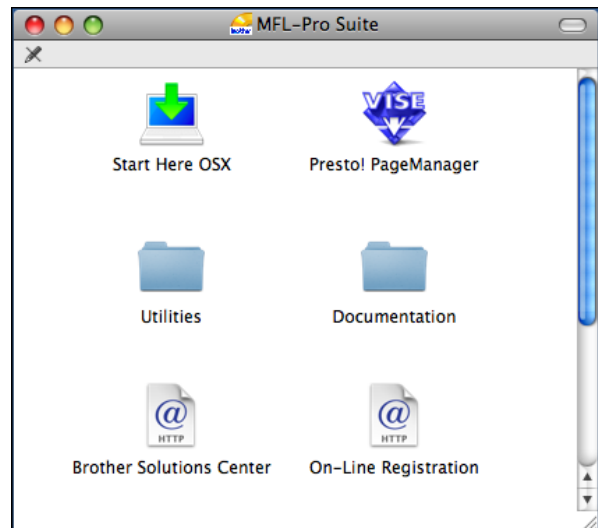

- 2 Double-click the **Documentation** icon.
- 3 Double-click your language folder.
- 4 Double-click top.html to view the **Software User's Guide** and **Network User's Guide** in HTML format.

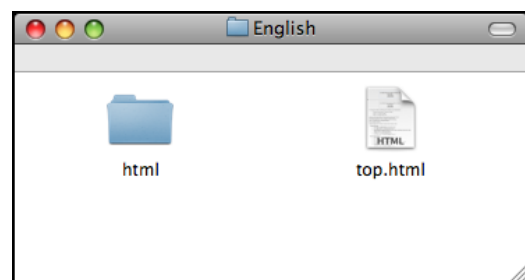

- 5 Click the documentation you want to read:
  - **Software User's Guide**
  - **Network User's Guide**

## How to find Scanning instructions

There are several ways you can scan documents. You can find the instructions as follows:

### Software User's Guide

- *Scanning* (For Mac OS® X 10.2.4 or greater)
- *ControlCenter2* (For Mac OS® X 10.2.4 or greater)
- *Network Scanning* (For Mac OS® X 10.2.4 or greater)

### Presto!® PageManager® User's Guide

- The complete Presto!® PageManager® User's Guide can be viewed from the Help selection in the Presto!® PageManager® application.

## How to find Network setup instructions (MFC-6490CW only)

Your machine can be connected to a wireless or wired network. You can find basic setup instructions in the Quick Setup Guide. If your wireless access point supports SecureEasySetup™, Wi-Fi Protected Setup™ or AOSS™, follow the steps in the Quick Setup Guide. For more information about network setup please see the Network User's Guide.

## Accessing Brother Support (For Windows®)

You can find all the contacts you will need, such as Web support (Brother Solutions Center).

- Click **Brother Support** on the main menu. The following screen will appear:



- To access our web site (<http://www.brother.com>), click **Brother Home Page**.
- For the latest news and product support information (<http://solutions.brother.com>), click **Brother Solutions Center**.
- To visit our web site for original Brother Supplies (<http://www.brother.com/original/>), click **Supplies Information**.
- To access the Brother CreativeCenter (<http://www.brother.com/creativecenter/>) for FREE photo projects and printable downloads, click **Brother CreativeCenter**.
- To return to the main page, click **Back** or if you have finished, click **Exit**.

# MFC-6490CW Control panel overview

The **MFC-5890CN** and **MFC-6490CW** have the same control panel keys.

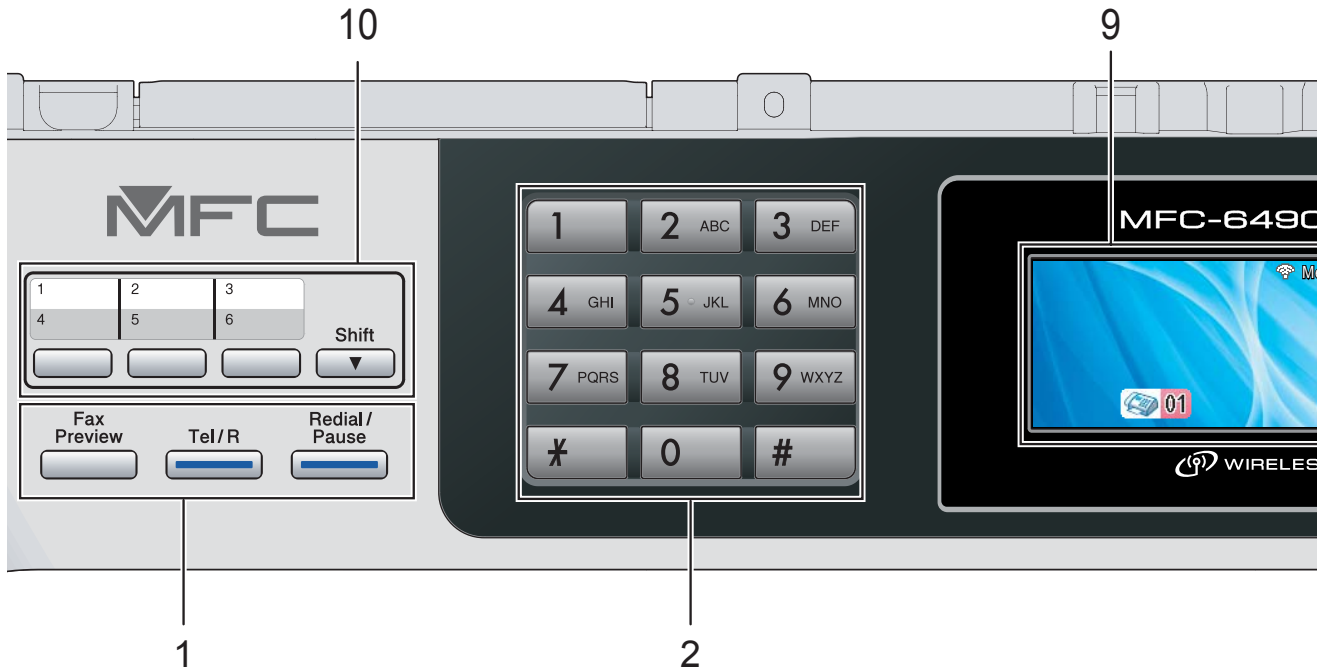

## Note

Most of the illustrations in this User's Guide show the MFC-6490CW.

### 1 Fax and telephone keys:

#### ■ Fax Preview

Lets you preview incoming and outgoing faxes on the LCD.

#### ■ Tel/R

This key is used to have a telephone conversation after picking up the external handset during the F/T pseudo-ring.

Also, when connected to a PBX, you can use this key to gain access to an outside line or to transfer a call to another extension.

#### ■ Redial/Pause

Redials the last 30 numbers called. It also inserts a pause when programming quick dial numbers.

### 2 Dial Pad

Use these keys to dial telephone and fax numbers and as a keyboard for entering information into the machine.

The **#** key lets you temporarily switch the dialling mode during a telephone call from Pulse to Tone.

### 3 Mode keys:

#### ■ Fax

Lets you access Fax mode.

#### ■ Scan

Lets you access Scan mode.

#### ■ Copy

Lets you access Copy mode.

#### ■ Photo Capture

Lets you access PhotoCapture Center™ mode.

### 4 Menu keys:

#### ■ Volume keys



When the machine is idle, you can press these keys to adjust the ring volume.

#### ■ Phone Book key



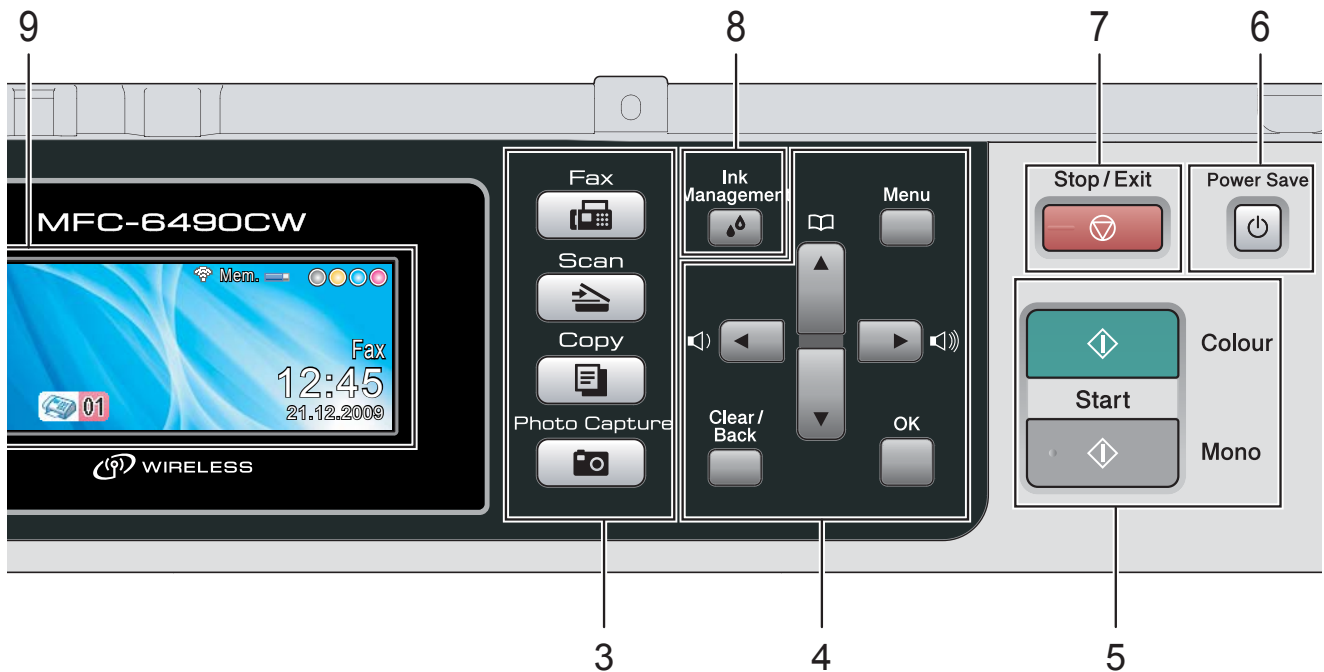

Press to store One Touch, Speed Dial and Group numbers in the machine's memory. Lets you store, look up, and dial numbers that are stored in the memory.



- ◀ or ▶  
Press to scroll backward or forward to a menu selection.  
Also, press to choose options.
- ▲ or ▼  
Press to scroll through the menus and options.
- **Menu**  
Access the main menu.
- **OK**  
Choose a setting.
- **Clear/Back**  
Press to delete characters or to go back to the previous menu level.

#### 5 Start keys:

-  **Colour Start**  
Lets you start sending faxes or making copies in full colour. Also lets you start a scanning operation (in colour or mono, depending on the scanning setting in the ControlCenter software).
-  **Mono Start**  
Lets you start sending faxes or making copies in monochrome. Also lets you start a scanning operation (in colour or mono depending on the scanning setting in the ControlCenter software).

- 6 **Power Save**  
Lets you put the machine into Power Save mode.
- 7  **Stop/Exit**  
Stops an operation or exits from a menu.
- 8 **Ink Management**  
Lets you clean the print head, check the print quality, and check the available ink volume.
- 9 **LCD (liquid crystal display)**  
Displays messages on the screen to help you set up and use your machine.  
Also, you can adjust the angle of the LCD by lifting it.
- 10 **One Touch keys**  
These 3 keys give you instant access to 6 previously stored numbers.  
**Shift**  
To access One Touch numbers 4 to 6, hold down **Shift** as you press the One Touch key.  
Also, if no number is assigned to the key, you can directly store the number by pressing the empty key.

## LCD screen indications

The LCD shows the current machine status when the machine is idle.



- 1 Wireless Status** (MFC-6490CW only)  
A four level indicator shows the current wireless signal strength if you are using a wireless connection.



- 2 Memory Status**  
Lets you see the available memory in the machine.
- 3 Ink indicator**  
Lets you see the available ink volume.
- 4 Current Receive Mode**  
Lets you see the current receive mode.
  - Fax (Fax only)
  - F/T (Fax/Tel)
  - TAD (External TAD)
  - Mn1 (Manual)

- 5 Faxes in memory**  
Shows how many received faxes are in the memory.

### Note

(MFC-6490CW)

If you receive a fax containing multiple paper sizes (for example, a page of A4 data and a page of A3 data), the machine may create and store a file for each paper size. The LCD may show that more than one fax job has been received.

## Basic Operations

The following steps show how to change a setting in the machine. In this example the Mode Timer setting is changed from 2 minutes to 30 seconds.

- Press **Menu**.
- Press **▲** or **▼** to choose **General Setup**.

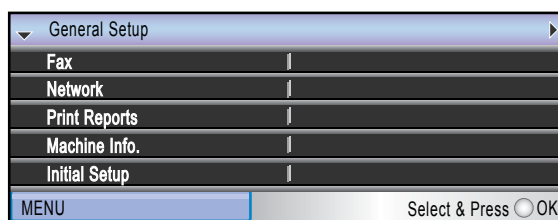

Press **OK**.

- Press **▲** or **▼** to choose **Mode Timer**.

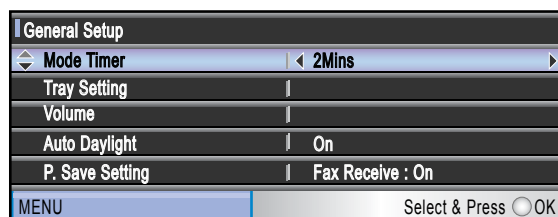

- Press **◀** or **▶** to choose **30Secs**.

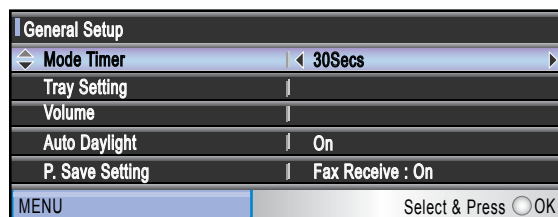

Press **OK**.

You can see the current setting on the LCD:

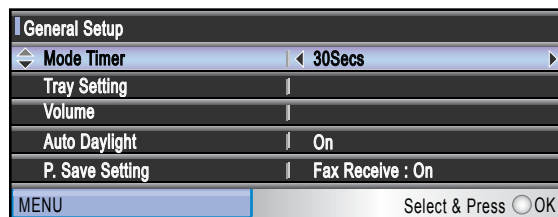

- Press **Stop/Exit**.

# 2

## Loading paper and documents

### Loading paper and other print media



#### Note

(MFC-6490CW only)

- For Tray #2, see *Loading paper in paper tray #2 (MFC-6490CW only)* on page 12.
- If the tray used for Fax mode is set to *Auto Select* you should open and close the scanner cover to reset the machine after refilling paper tray #1.

### Loading paper in paper tray #1

- 1 If the paper support flap is open, close it, and then close the paper support. Pull the paper tray completely out of the machine.

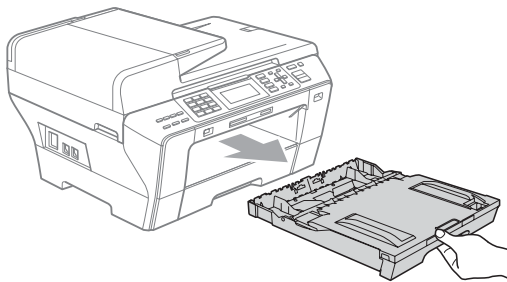

#### Note

- When you are using A3, Legal or Ledger size paper, press and hold the universal guide release button (1) as you slide out the front of the paper tray.

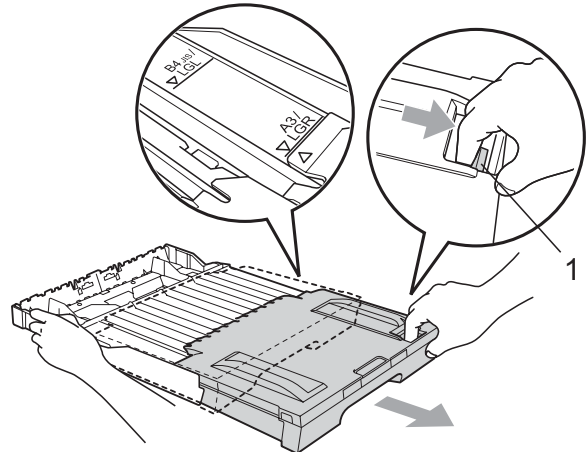

- If you are using A5 or smaller size paper, make sure that the paper tray is not extended.

2

Open the paper tray cover (1).

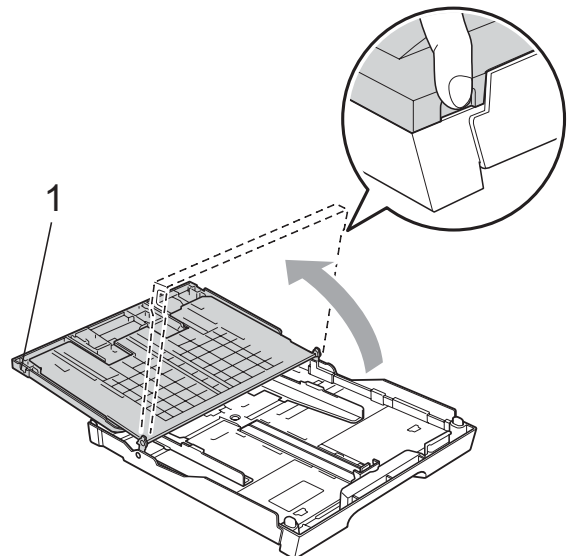

- 3 With both hands, gently press and slide the paper side guides (1) and then the paper length guide (2) to fit the paper size. Make sure that the triangular marks (3) on the paper side guides (1) and paper length guide (2) line up with the mark for the paper size you are using.

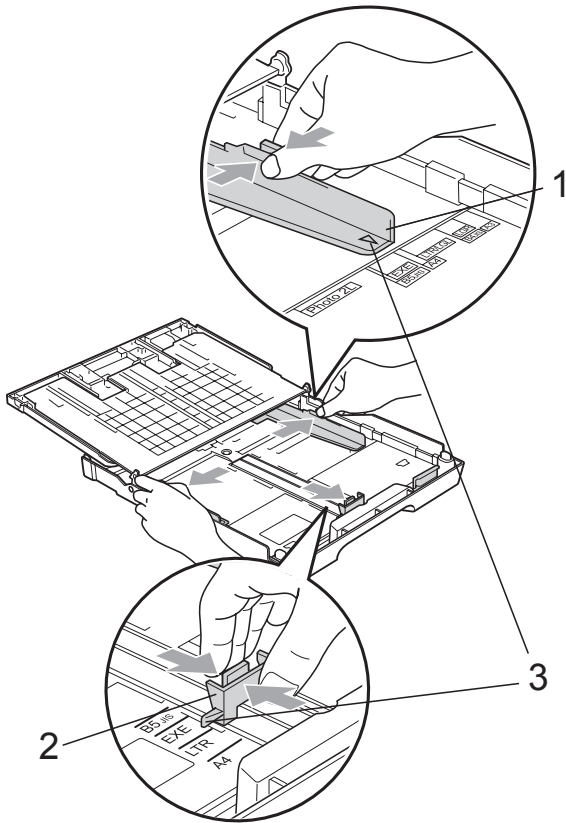

- 4 Fan the stack of paper well to avoid paper jams and misfeeds.

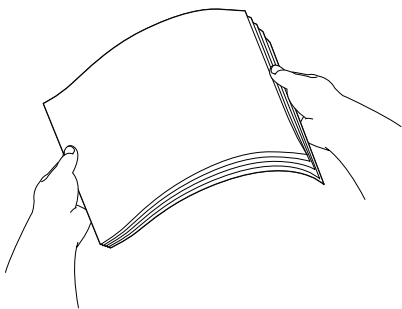

 **Note**

Always make sure that the paper is not curled.

- 5 Gently put the paper into the paper tray print side down and top edge in first. Check that the paper is flat in the tray.

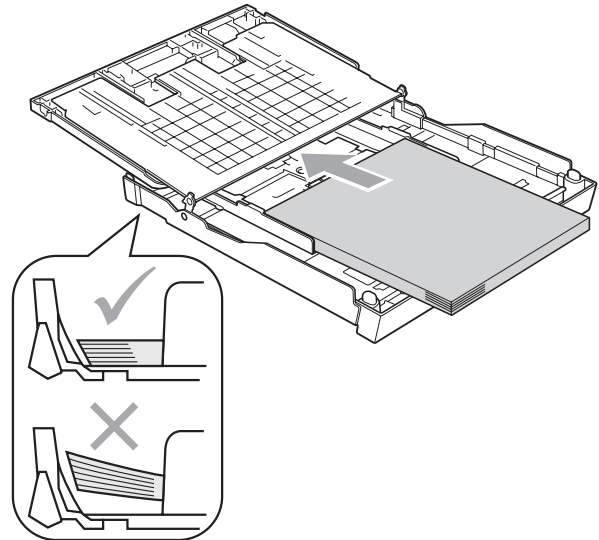

- 6 Gently adjust the paper side guides to the paper with both hands. Make sure the paper side guides touch the sides of the paper.

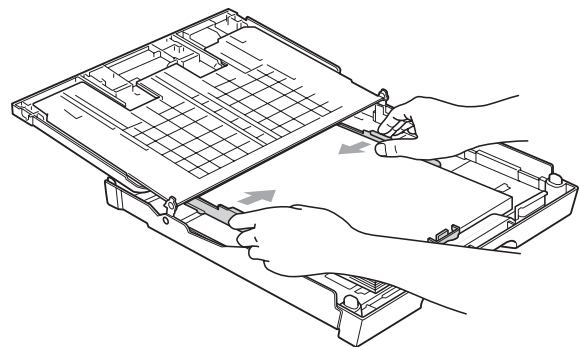

 **Note**

Be careful that you do not push the paper in too far; it may lift at the back of the tray and cause feed problems.

- 7 Close the paper tray cover. Check that the paper is flat in the tray and below the maximum paper mark (1).

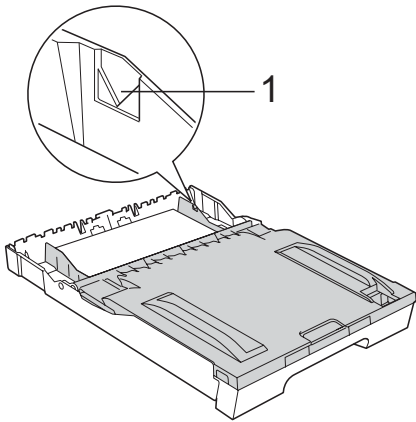

- 8 Slowly push the paper tray completely into the machine.

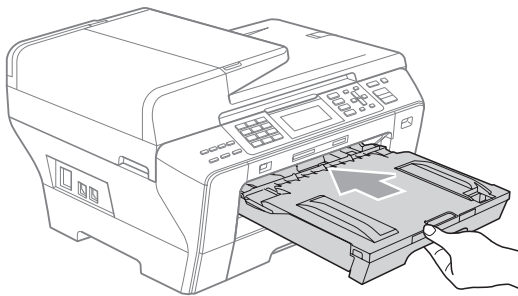

### WARNING

DO NOT push Tray #1 into the machine too quickly. Doing this may cause injury to your hand by trapping it between Tray #1 and Tray #2. Please push Tray #1 slowly.

- 9 While holding the paper tray in place, pull out the paper support (1) until it clicks and unfold the paper support flap (2).

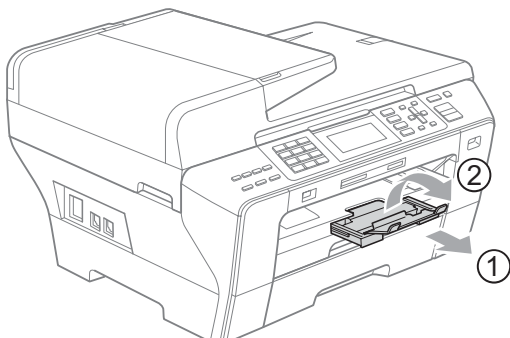

### Note

When you shorten Tray#1, take the paper out of the tray. Then shorten the tray by pressing the universal guide release button (1). Adjust the paper length guide (2) to fit the paper size you are going to use. Then put the paper into the tray.

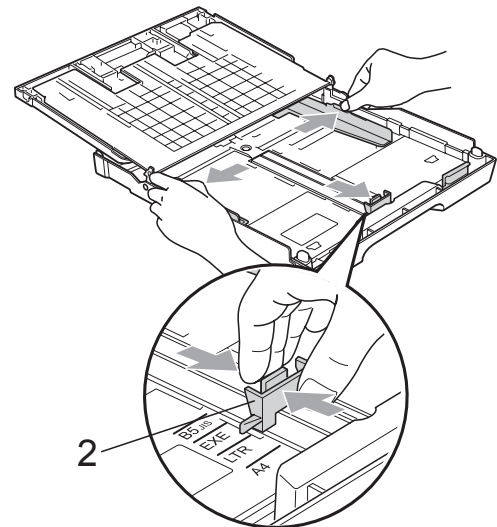
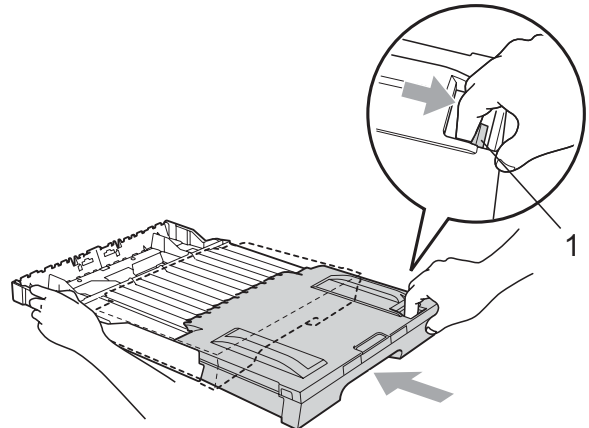

## Loading paper in paper tray #2 (MFC-6490CW only)

### Note

You can only use plain paper sizes A3, A4, Ledger, Letter, Legal or Executive in Tray #2.

- 1 Pull the paper tray completely out of the machine.

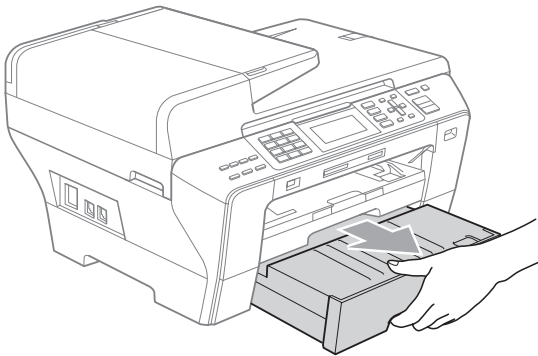

- 2 Take off the paper tray cover (1).

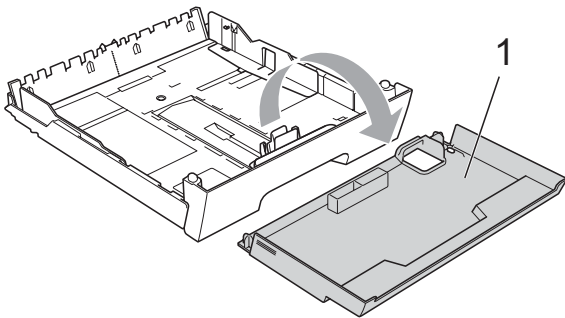

- 3 With both hands, gently press and slide the paper side guides (1) and then the paper length guide (2) to fit the paper size.

Make sure that the triangular marks (3) on the paper side guides (1) and paper length guide (2) line up with the mark for the paper size you are using.

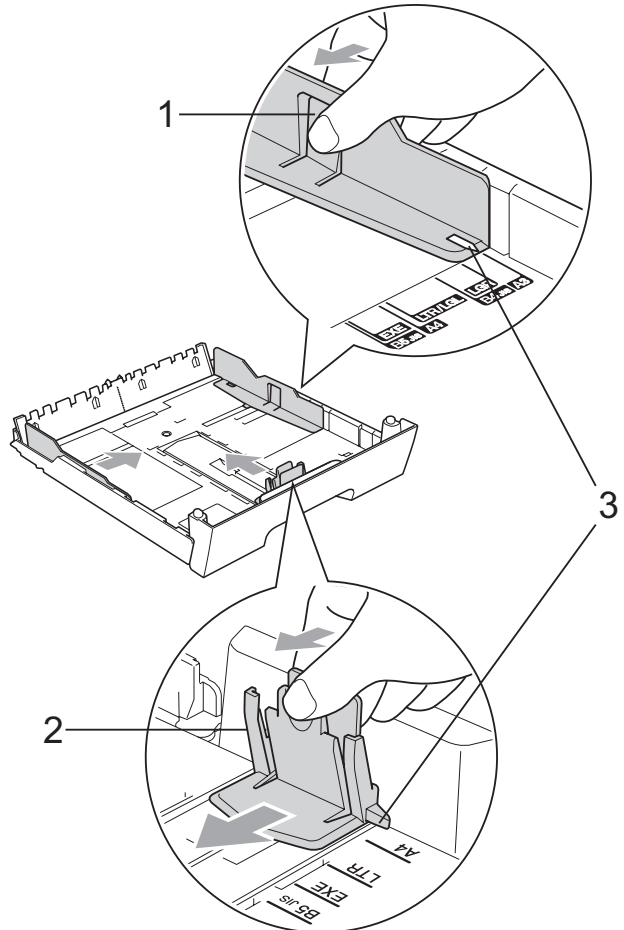

**Note**

If you are using Ledger, Legal or A3 size paper, press and hold the universal guide release button (1) as you slide out the front of the paper tray.

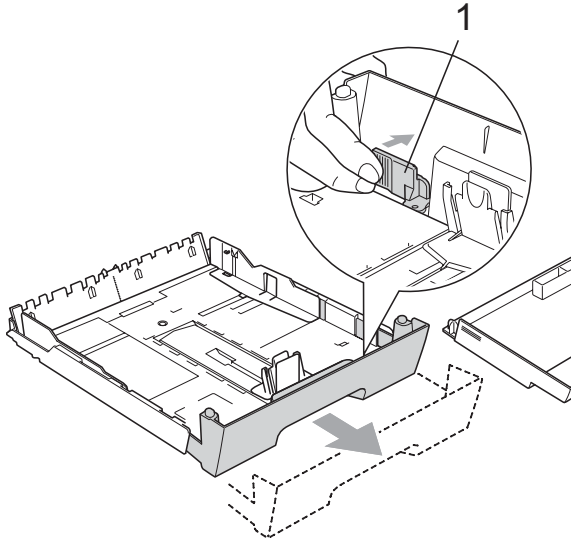

- 4 Fan the stack of paper well to avoid paper jams and misfeeds.

**Note**

Always make sure that the paper is not curled.

- 5 Gently put the paper into the paper tray print side down and top edge in first. Check that the paper is flat in the tray and below the maximum paper mark (1).

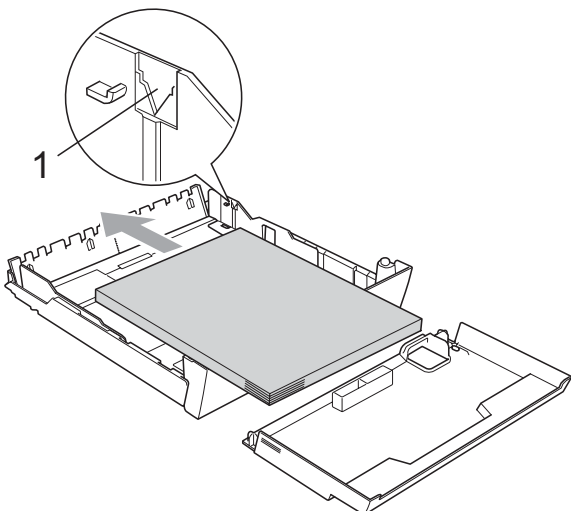

- 6 Gently adjust the paper side guides with both hands to fit the paper stack. Make sure the paper side guides touch the sides of the paper.

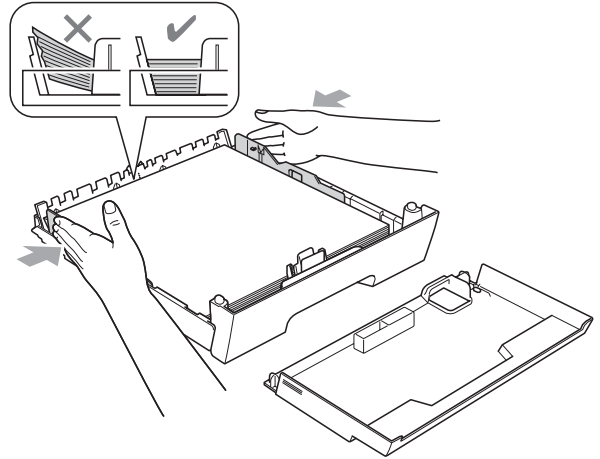
**Note**

Be careful that you do not push the paper in too far; it may lift at the back of the tray and cause feed problems.

- 7 Put on the paper tray cover.

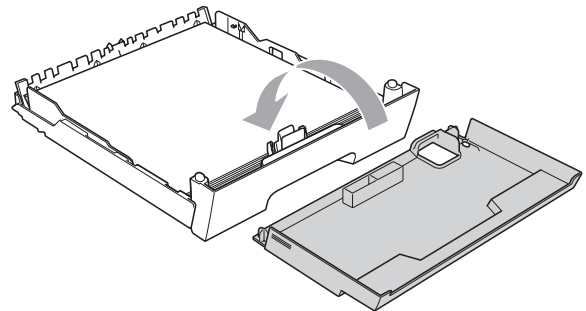

- 8 Slowly push the paper tray back into the machine.

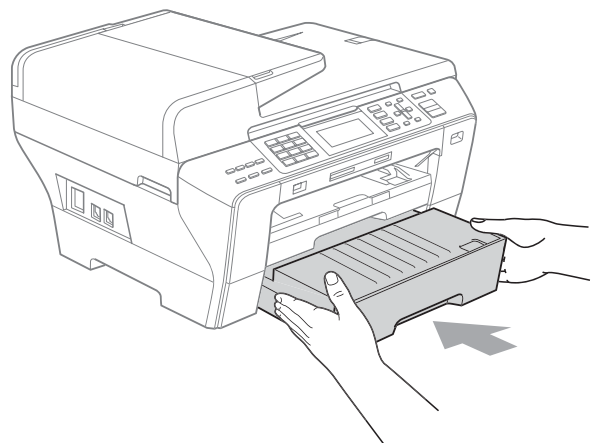

- 9 If you are using A3, Ledger or Legal size paper, complete the following steps. Pull Tray #1 out of the machine.

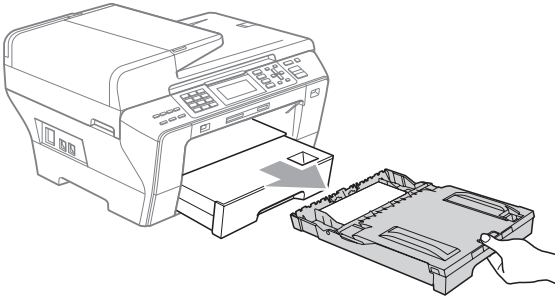

- 10 Press and hold the universal guide release button (1) as you slide out the front of the paper tray.

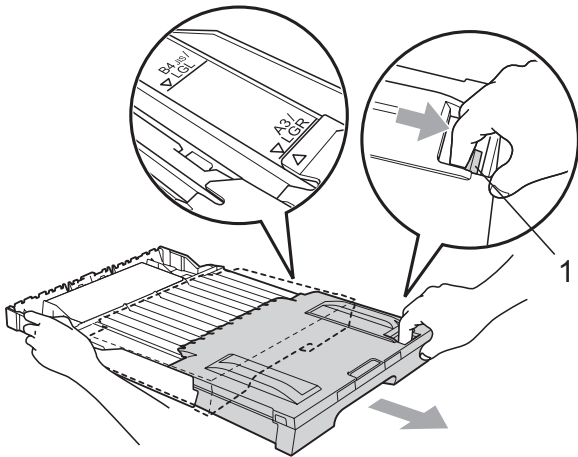

- 11 Open the paper tray cover and adjust the per length guide (1) for the paper.

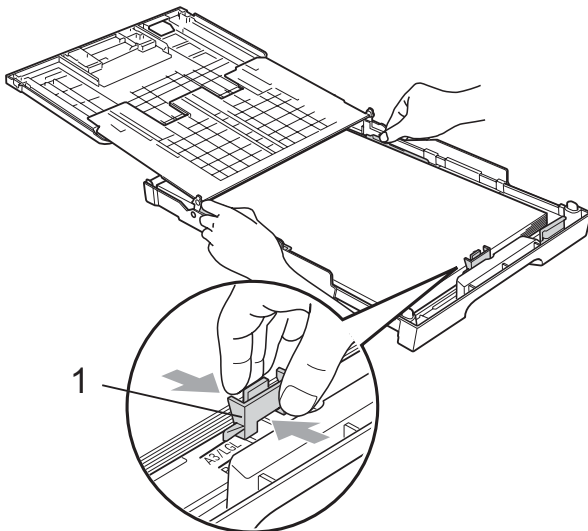

- 12 Close the paper tray cover and *slowly* push the paper tray into the machine. Pull out the paper support (1) until it clicks and unfold the paper support flap (2).

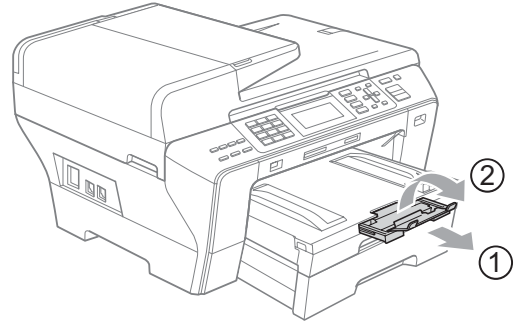

 **Note**

If you are finished using A3, Ledger or Legal size paper and want to use a smaller paper size, take the paper out of the tray. Then shorten the tray by pressing the universal guide release button (1). Adjust the paper length guide (2) to fit the paper size you are going to use. Then put the smaller paper into the tray.

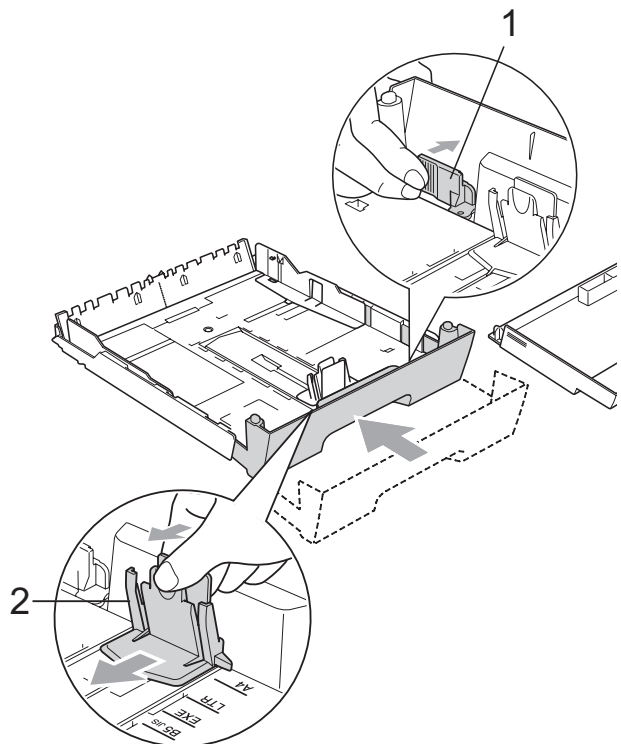

## Loading envelopes and postcards



### About envelopes

- Use envelopes that weigh between 80 to 95 g/m<sup>2</sup>.
- Some envelopes need margin settings to be set in the application. Make sure you do a test print first before printing many envelopes.

### ! CAUTION

DO NOT use any of the following types of envelopes, as they will cause paper feed problems:

- That are of a baggy construction.
- That are embossed (have raised writing on them).
- That have clasps or staples.
- That are pre-printed on the inside.

Glue	Double flap
	

Occasionally you may experience paper feed problems caused by the thickness, size and flap shape of the envelopes you are using.

### How to load envelopes and postcards

- 1 Before loading, press the corners and sides of envelopes or post cards to make them as flat as possible.



#### Note

If envelopes or post cards are 'double-feeding', put one envelope or post card in the paper tray at a time.

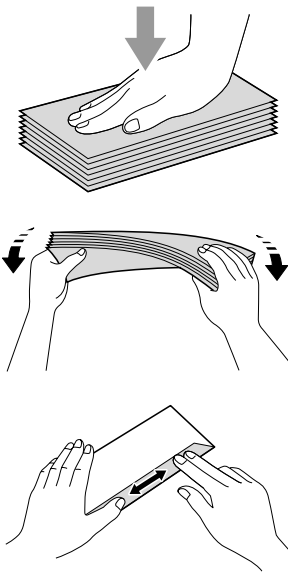

- Put envelopes or post cards in the paper tray with the address side down and the leading edge (top of the envelopes) in first. With both hands, gently press and slide the paper side guides (1) and paper length guide (2) to fit the size of the envelopes or post cards.

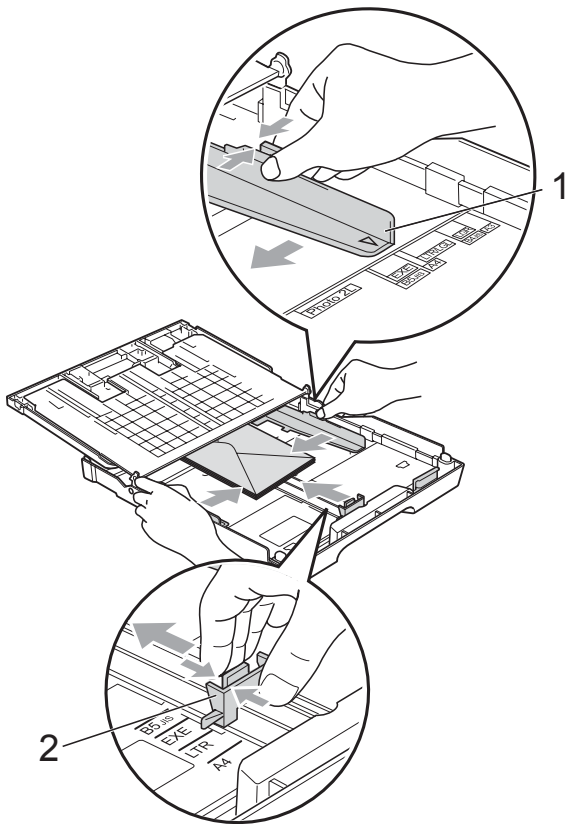

**If you have problems when printing on envelopes, try the following suggestions:**

- Make sure the flap is either to the side of the envelope or to the back edge of the envelope when printing.
- Adjust the size and margin in your application.

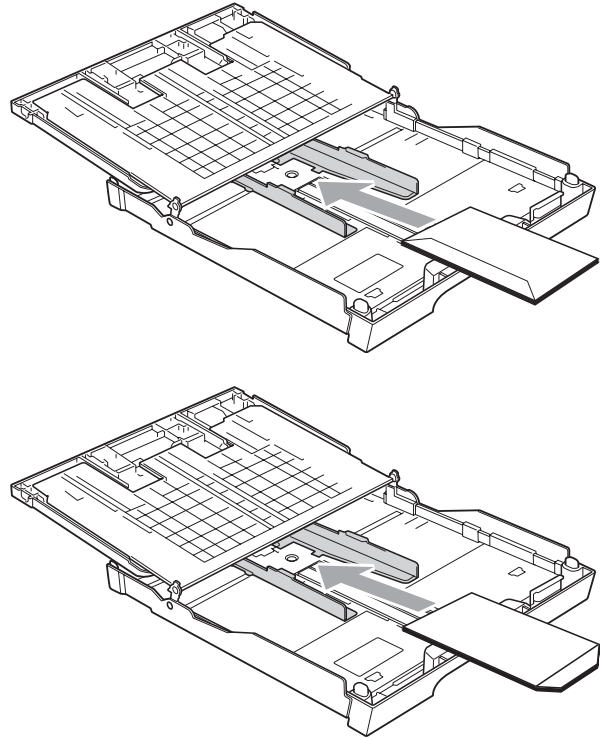

**Removing small printouts from the machine**

When the machine ejects small paper onto the output paper tray you may not be able to reach it. Make sure printing has finished, and then pull the tray completely out of the machine.

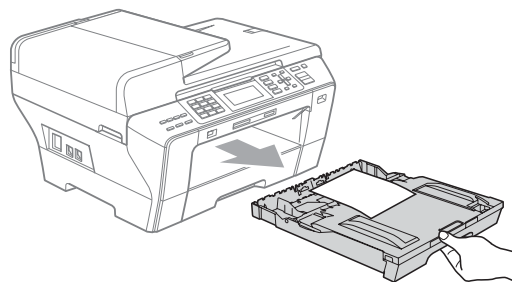

## Printable area

The printable area depends on the settings in the application you are using. The figures below show the unprintable areas on cut sheet paper and envelopes. The machine can print in the shaded areas of cut sheet paper when the Borderless print feature is available and turned on. (See *Printing for Windows*<sup>®</sup> or *Printing and Faxing for Macintosh*<sup>®</sup> in the Software User's Guide on the CD-ROM.)

### Cut Sheet Paper

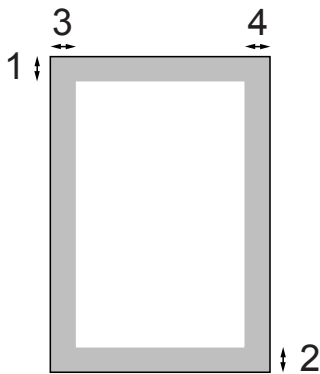

### Envelopes

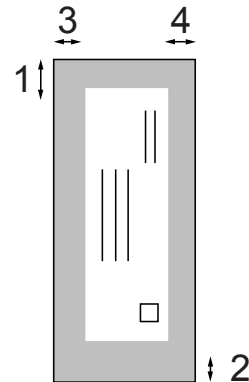

	Top (1)	Bottom (2)	Left (3)	Right (4)
Cut Sheet	3 mm	3 mm	3 mm	3 mm
Envelopes	12 mm	24 mm	3 mm	3 mm



### Note

The Borderless feature is not available for envelopes.

## Acceptable paper and other print media

The print quality can be affected by the type of paper you use in the machine.

To get the best print quality for the settings you have chosen, always set the Paper Type to match the type of paper you load.

You can use plain paper, inkjet paper (coated paper), glossy paper, transparencies and envelopes.

We recommend testing various paper types before buying large quantities.

For best results, use Brother paper.

- When you print on inkjet paper (coated paper), transparencies and photo paper, be sure to choose the correct print media in the '**Basic**' tab of the printer driver or in the Paper Type setting of the menu. (See *Paper Size and Type (MFC-6490CW only)* on page 27.)
- When you print on Brother Photo paper, load one extra sheet of the same photo paper in the paper tray. An extra sheet has been included in the paper package for this purpose.
- When you use transparencies or photo paper, remove each sheet at once to prevent smudging or paper jams.
- Avoid touching the printed surface of the paper immediately after printing; the surface may not be completely dry and may stain your fingers.

## Recommended print media

To get the best print quality, we suggest using Brother paper. (See table below.)

If Brother paper is not available in your country, we recommend testing various papers before purchasing large quantities.

We recommend using '3M Transparency Film' when you print on transparencies.

### Brother paper

Paper Type	Item
A3 Plain	BP60PA3
A3 Glossy Photo	BP71GA3
A3 Inkjet (Matte)	BP60MA3
A4 Plain	BP60PA
A4 Glossy Photo	BP71GA4
A4 Inkjet (Matte)	BP60MA
10 x 15 cm Glossy Photo	BP71GP

## Handling and using print media

- Store paper in its original packaging, and keep it sealed. Keep the paper flat and away from moisture, direct sunlight and heat.
- Avoid touching the shiny (coated) side of photo paper. Load photo paper with the shiny side facing down.
- Avoid touching either side of transparencies because they absorb water and perspiration easily, and this may cause decreased output quality. Transparencies designed for laser printers/copiers may stain your next document. Use only transparencies recommended for inkjet printing.
- You can only print on both sides of the paper with PC printing. (See *Printing* for Windows® in the Software User's Guide on the CD-ROM.)

### Improper Setup

DO NOT use the following kinds of paper:

- Damaged, curled, wrinkled, or irregularly shaped paper

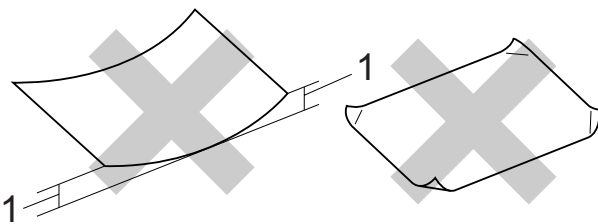

**1 2 mm or greater**

- Extremely shiny or highly textured paper
- Paper that cannot be arranged uniformly when stacked

## Paper capacity of the paper tray

Up to 50 sheets of 80 g/m<sup>2</sup> A4 paper.

- Transparencies and photo paper must be picked up from the output paper tray one page at a time to avoid smudging.

## Choosing the right print media

### Paper type and size for each operation

Paper Type	Paper Size		Usage			
			Fax	Copy	Photo Capture	Printer
Cut Sheet	Ledger	279.4 × 431.8 mm (11 × 17 in.)	Yes	Yes	Yes	Yes
	A3	297 × 420 mm (11.7 × 16.5 in.)	Yes	Yes	Yes	Yes
	Letter	215.9 × 279.4 mm (8 1/2 × 11 in.)	Yes	Yes	Yes	Yes
	A4	210 × 297 mm (8.3 × 11.7 in.)	Yes	Yes	Yes	Yes
	Legal	215.9 × 355.6 mm (8 1/2 × 14 in.)	Yes	Yes	–	Yes
	Executive	184 × 267 mm (7 1/4 × 10 1/2 in.)	–	–	–	Yes
	JIS B4	257 × 364 mm (10.1 × 14.3 in.)	–	–	–	Yes
	JIS B5	182 × 257 mm (7.2 × 10.1 in.)	–	–	–	Yes
	A5	148 × 210 mm (5.8 × 8.3 in.)	–	Yes	–	Yes
A6	105 × 148 mm (4.1 × 5.8 in.)	–	–	–	Yes	
Cards	Photo	10 × 15 cm (4 × 6 in.)	–	Yes	Yes	Yes
	Photo L	89 × 127 mm (3 1/2 × 5 in.)	–	–	–	Yes
	Photo 2L	13 × 18 cm (5 × 7 in.)	–	–	Yes	Yes
	Index Card	127 × 203 mm (5 × 8 in.)	–	–	–	Yes
	PostCard1	100 × 148 mm (3.9 × 5.8 in.)	–	–	–	Yes
	PostCard2 (Double)	148 × 200 mm (5.8 × 7.9 in.)	–	–	–	Yes
Envelopes	C5 Envelope	162 × 229 mm (6.4 × 9 in.)	–	–	–	Yes
	DL Envelope	110 × 220 mm (4.3 × 8.7 in.)	–	–	–	Yes
	COM-10	105 × 241 mm (4 1/8 × 9 1/2 in.)	–	–	–	Yes
	Monarch	98 × 191 mm (3 7/8 × 7 1/2 in.)	–	–	–	Yes
	JE4 Envelope	105 × 235 mm (4.1 × 9.3 in.)	–	–	–	Yes
Transparencies	Letter	215.9 × 279.4 mm (8 1/2 × 11 in.)	–	Yes	–	Yes
	A4	210 × 297 mm (8.3 × 11.7 in.)	–	Yes	–	Yes

## Paper weight, thickness and capacity

Paper Type		Weight	Thickness	No. of sheets
Cut Sheet	Plain Paper	64 to 120 g/m <sup>2</sup>	0.08 to 0.15 mm	150 <sup>1</sup>
	(Tray #2) Plain Paper	(MFC-6490CW) 64 to 105 g/m <sup>2</sup>	0.08 to 0.15 mm	250 <sup>2</sup>
	Inkjet Paper	64 to 200 g/m <sup>2</sup>	0.08 to 0.25 mm	20
	Glossy Paper	Up to 220 g/m <sup>2</sup>	Up to 0.25 mm	20
Cards	Photo Card	Up to 220 g/m <sup>2</sup>	Up to 0.25 mm	20
	Index Card	Up to 120 g/m <sup>2</sup>	Up to 0.15 mm	30
	PostCard	Up to 200 g/m <sup>2</sup>	Up to 0.25 mm	30
Envelopes		75 to 95 g/m <sup>2</sup>	Up to 0.52 mm	10
Transparencies		–	–	10

<sup>1</sup> Up to 150 sheets of 80 g/m<sup>2</sup> paper.

<sup>2</sup> Up to 250 sheets of 80 g/m<sup>2</sup> paper.

## Loading documents

You can send a fax, make copies, and scan from the ADF (automatic document feeder) and from the scanner glass.

### Using the ADF

The ADF can hold up to 50 pages and feeds each sheet individually. Use standard 80 g/m<sup>2</sup> paper and always fan the pages before putting them in the ADF.

### Recommended environment

Temperature:	20° C to 30° C
Humidity:	50% to 70%
Paper:	80 g/m <sup>2</sup>

### Document Sizes Supported

Length:	(MFC-5890CN) 148 to 355.6 mm (MFC-6490CW) 148 to 431.8 mm
Width:	(MFC-5890CN) 148 to 215.9 mm (MFC-6490CW) 148 to 297 mm
Weight:	64 to 90 g/m <sup>2</sup>

## How to load documents

### ! CAUTION

DO NOT pull on the document while it is feeding.

DO NOT use paper that is curled, wrinkled, folded, ripped, stapled, paper clipped, pasted or taped.

DO NOT use cardboard, newspaper or fabric.

- Make sure documents written with ink are completely dry.

- 1 Unfold the ADF Document Support (1) and the ADF Document Output Support Flap (2).

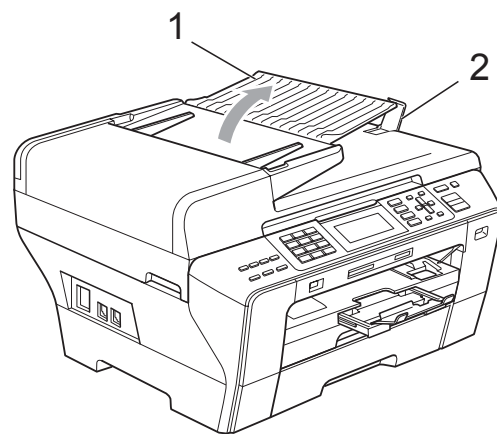

- 2 Fan the pages well.
- 3 Adjust the paper guides (1) to fit the width of your documents.

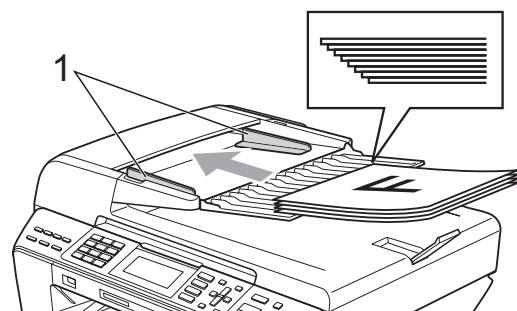

- 4 Place your documents, **face up, top edge first** in the ADF until you feel them touch the feed roller.



### Note

(MFC-6490CW only)

Insert A4/Letter documents short-edge first.

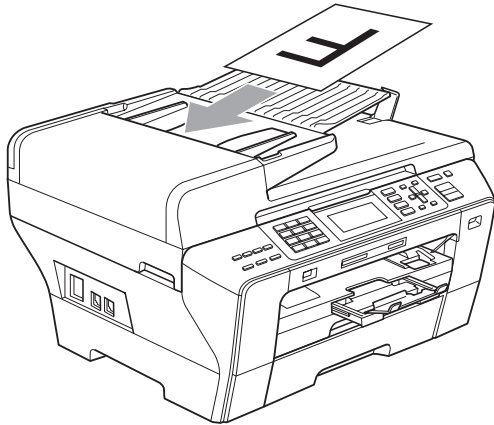

### CAUTION

DO NOT leave thick documents on the scanner glass. If you do this, the ADF may jam.

## Using the scanner glass

You can use the scanner glass to fax, copy or scan pages of a book or one page at a time.

### Document Sizes Supported

Length:	(MFC-5890CN) Up to 297 mm (MFC-6490CW) Up to 431.8 mm
Width:	(MFC-5890CN) Up to 215.9 mm (MFC-6490CW) Up to 297 mm
Weight:	Up to 2 kg

## How to load documents



### Note

To use the scanner glass, the ADF must be empty.

- 1 Lift the document cover.
- 2 Using the document guidelines on the left and top, place the document face down in the upper left corner of the scanner glass.

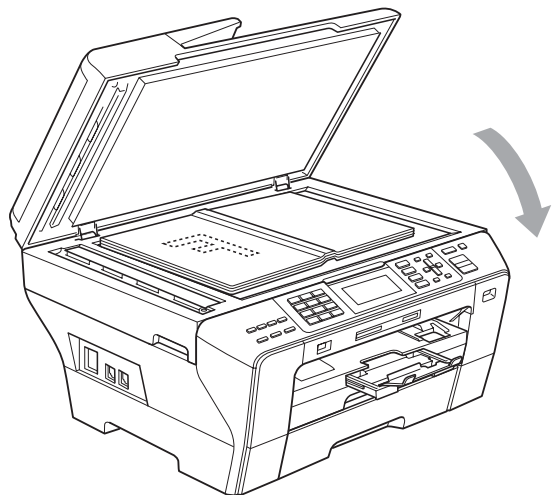
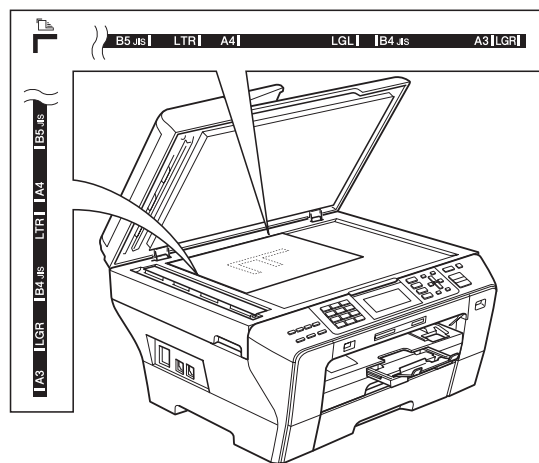

- 3 Close the document cover.



### CAUTION

If you are scanning a book or thick document, DO NOT slam the cover down or press on it.

## Scannable area

The scannable area depends on the settings in the application you are using. The figures below show the unscannable area.

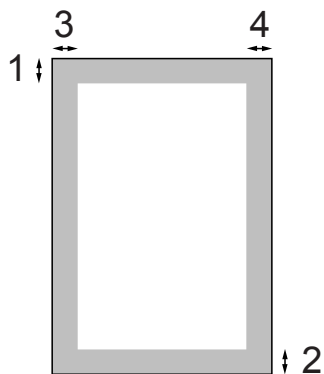

Usage	Document Size	Top (1) Bottom (2)	Left (3) Right (4)
Fax	Ledger (MFC-6490CW only)	3 mm	3.7 mm
	A3 (MFC-6490CW only)	3 mm	4.5 mm
	Letter	3 mm	4 mm
	A4	3 mm	(Scanner Glass) 3 mm (ADF) 1 mm
	Legal	3 mm	4 mm
Copy	All paper sizes	3 mm	3 mm
Scan	All paper sizes	3 mm	3 mm

## Power Save mode

To maintain print quality, prolong print head life, and provide the best ink cartridge economy, you should keep your machine connected to the power at all times.

You can put the machine into Power Save mode by pressing the **Power Save** key. You can still receive telephone calls in Power Save mode. For further information on receiving faxes in the Power Save condition, please see the table on page 25. The delayed faxes that have been set up will be sent. You can even retrieve faxes using Remote Retrieval if you are away from your machine. If you want to do other operations, you must take the machine out of Power Save mode.



### Note

If you have connected an external telephone or TAD, it is always available.

## Putting your machine in Power Save mode

- 1 Press and hold down the **Power Save** key until the LCD shows *Shutting Down*. The LCD will stay on for a few seconds before going off.

## Bringing your machine out of Power Save mode

- 1 Press the **Power Save** key. The LCD shows the date and time.



### Note

- Even if you have put the machine into Power Save mode, it will periodically clean the print head to preserve print quality.
- You can customize Power Save mode so that, apart from automatic head cleaning, no machine operations are available. (See *Power Save setting* on page 25.)

## Power Save setting

You can customize the machine's **Power Save** key. The factory setting is `Fax Receive:On`. Your machine can receive faxes or calls even when the machine is in Power Save mode. If you do not want your machine to receive faxes or calls, turn this setting to `Fax Receive:Off`.

- 1 Press **Menu**.
- 2 Press **▲** or **▼** to choose *General Setup*. Press **OK**.
- 3 Press **▲** or **▼** to choose *P.Save Setting*.
- 4 Press **◀** or **▶** to choose `Fax Receive:Off` (or `Fax Receive:On`). Press **OK**.
- 5 Press **Stop/Exit**.

On/Off setting	Receive mode	Available operations
Fax Receive: On <sup>1</sup> (factory setting)	Fax Only External TAD	Fax Receive Fax Detect Delayed Fax <sup>3</sup> Fax Forward <sup>3</sup> Fax Storage <sup>3</sup> Fax Preview <sup>3</sup> PC Fax Receive <sup>3</sup> Remote Retrieval <sup>3</sup>
	Manual Fax/Tel <sup>2</sup>	Fax Detect Delayed Fax <sup>3</sup>
Fax Receive: Off	—	No machine operations will be available other than cleaning the print head.

<sup>1</sup> You cannot receive a fax with **Mono Start** or **Colour Start**.

<sup>2</sup> You cannot receive a fax automatically if you have set the receive mode to `Fax/Tel`.

<sup>3</sup> Set before you switch off the machine.

## Mode Timer

The machine has four temporary mode keys on the control panel: **Fax**, **Scan**, **Copy** and **Photo Capture**. You can change the amount of time the machine takes after the last Scan, Copy or PhotoCapture operation before it returns to Fax mode. If you choose *Off*, the machine stays in the mode you used last.

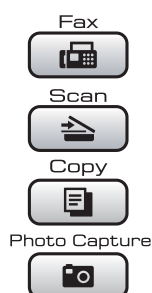

- 1 Press **Menu**.
- 2 Press **▲** or **▼** to choose **General Setup**. Press **OK**.
- 3 Press **▲** or **▼** to choose **Mode Timer**.
- 4 Press **◀** or **▶** to choose **0Sec**, **30Secs**, **1Min**, **2Mins**, **5Mins** or **Off**. Press **OK**.
- 5 Press **Stop/Exit**.

## Paper settings

### Paper Size and Type (MFC-5890CN only)

#### Paper Type

To get the best print quality, set the machine for the type of paper you are using.

- 1 Press **Menu**.
- 2 Press **▲** or **▼** to choose **General Setup**. Press **OK**.
- 3 Press **▲** or **▼** to choose **Paper Type**.
- 4 Press **◀** or **▶** to choose **Plain Paper**, **Inkjet Paper**, **Brother BP71**, **Other Glossy** or **Transparency**. Press **OK**.
- 5 Press **Stop/Exit**.



#### Note

The machine ejects paper with printed surfaces face up onto the paper tray in front of the machine. When you use transparencies or glossy paper, remove each sheet at once to prevent smudging or paper jams.

## Paper Size

You can use seven sizes of paper for printing copies: A4, A5, A3, 10 × 15 cm (4 × 6 in.), Letter, Legal and Ledger and five sizes for printing faxes: Ledger, Letter, Legal, A3 and A4. When you change the size of paper you load in the machine, you will need to change the paper size setting at the same time so your machine can fit an incoming fax on the page.

- 1 Press **Menu**.
- 2 Press **▲** or **▼** to choose **General Setup**. Press **OK**.
- 3 Press **▲** or **▼** to choose **Paper Size**.
- 4 Press **◀** or **▶** to choose A4, A5, A3, 10x15cm, Letter, Legal, and Ledger. Press **OK**.
- 5 Press **Stop/Exit**.

## Paper Size and Type (MFC-6490CW only)

To get the best print quality, set the machine for the type of paper you are using.

You can use seven sizes of paper for printing copies: A3, A4, A5, 10 × 15 cm (4 × 6 in.), Ledger, Letter and Legal and five sizes for printing faxes: A3, A4, Ledger, Letter and Legal. When you load a different size of paper in the machine, you will need to change the paper size setting at the same time so your machine can fit an incoming fax on the page.

- 1 Press **Menu**.
- 2 Press **▲** or **▼** to chose **General Setup**. Press **OK**.
- 3 Press **▲** or **▼** to chose **Tray Setting**. Press **OK**.
- 4 Press **▲** or **▼** to choose **Tray#1** or **Tray#2**. Press **OK**.

- 5 Do one of the following:
  - If you chose **Tray#1**, press **◀** or **▶** to choose **Plain Paper**, **Inkjet Paper**, **Brother BP71**, **Other Glossy** or **Transparency**. Press **OK**. Press **▲** or **▼** to choose **Paper Size** and press **◀** or **▶** to choose A4, A5, A3, 10x15cm, Letter, Legal or Ledger. Press **OK**.
  - If you chose **Tray#2**, press **▲** or **▼** to choose **Paper Size** and press **◀** or **▶** to choose A4, A3, Letter, Legal or Ledger. Press **OK**.
- 6 Press **Stop/Exit**.



### Note

- You can only use plain paper and paper sizes A3, A4, Ledger, Letter or Legal in Tray #2.
- The machine ejects paper with printed surfaces face up onto the paper tray in front of the machine. When you use transparencies or glossy paper, remove each sheet at once to prevent smudging or paper jams.

## Tray use in Copy mode (MFC-6490CW only)

---

You can change the default tray the machine will use for printing copies.

To change the default setting follow the instructions below:

- 1 Press **Menu**.
- 2 Press **▲** or **▼** to choose `General Setup`. Press **OK**.
- 3 Press **▲** or **▼** to choose `Tray Setting`. Press **OK**.
- 4 Press **▲** or **▼** to choose `Tray Use:Copy`.
- 5 Press **◀** or **▶** to choose `Tray#1` or `Tray#2`. Press **OK**.
- 6 Press **Stop/Exit**.



### Note

---

You can change the paper size and tray selection temporarily for the next copy. (See *Paper Size* on page 93 and *Tray Select (MFC-6490CW only)* on page 93.)

---

## Tray use in Fax mode (MFC-6490CW only)

---

You can change the default tray the machine will use for printing received faxes.

`Auto Select` will allow your machine to take paper from Tray #1 first, or from Tray #2 if:

- Tray #1 is out of paper.
- Tray #2 is set to a different paper size that is more suitable for the received faxes.
- Both trays are using the same size paper and Tray #1 is not set to use plain paper.

- 1 Press **Menu**.
- 2 Press **▲** or **▼** to choose `General Setup`. Press **OK**.
- 3 Press **▲** or **▼** to choose `Tray Setting`. Press **OK**.
- 4 Press **▲** or **▼** to choose `Tray Use:Fax`.
- 5 Press **◀** or **▶** to choose `Tray#1`, `Tray#2` or `Auto Select`. Press **OK**.
- 6 Press **Stop/Exit**.

## Secure Paper Feed mode for A3 size Short Grain Paper

If your print data has horizontal lines when using A3 paper, your paper may be long grain paper. Choose **A3 - Short Grain** to **Off** to avoid this problem.

- 1 Press **Menu**.
- 2 Press **▲** or **▼** to choose **General Setup**. Press **OK**.
- 3 Press **▲** or **▼** to choose **A3 - Short Grain**.
- 4 Press **◀** or **▶** to choose **Off**. Press **OK**.
- 5 Press **Stop/Exit**.



### Note

- If you are not sure about the type of paper you are using, consult the paper packaging or manufacturer for paper specifications.
- Printing will be slower when using the **A3 - Short Grain** setting **On**.

## Volume Settings

### Ring Volume

You can choose a range of ring volume levels, from **High** to **Off**.

While the machine is idle, press **◀** or **▶** to adjust the volume level. The LCD shows the current setting, and each key press will change the volume to the next level. The machine will keep the new setting until you change it. You can also change the volume through the menu, by following the instructions below:

### Setting the Ring Volume from the menu

- 1 Press **Menu**.
- 2 Press **▲** or **▼** to choose **General Setup**. Press **OK**.
- 3 Press **▲** or **▼** to choose **Volume**. Press **OK**.
- 4 Press **▲** or **▼** to choose **Ring**.
- 5 Press **◀** or **▶** to choose **Low**, **Med**, **High** or **Off**. Press **OK**.
- 6 Press **Stop/Exit**.

## Beeper Volume

---

When the beeper is on, the machine will beep when you press a key, make a mistake or after you send or receive a fax.

You can choose a range of volume levels, from *High* to *Off*.

- 1 Press **Menu**.
- 2 Press ▲ or ▼ to choose *General Setup*. Press **OK**.
- 3 Press ▲ or ▼ to choose *Volume*. Press **OK**.
- 4 Press ▲ or ▼ to choose *Beeper*.
- 5 Press ◀ or ▶ to choose *Low*, *Med*, *High* or *Off*. Press **OK**.
- 6 Press **Stop/Exit**.

## Speaker Volume

---

You can choose a range of speaker volume levels, from *High* to *Off*.

- 1 Press **Menu**.
- 2 Press ▲ or ▼ to choose *General Setup*. Press **OK**.
- 3 Press ▲ or ▼ to choose *Volume*. Press **OK**.
- 4 Press ▲ or ▼ to choose *Speaker*.
- 5 Press ◀ or ▶ to choose *Low*, *Med*, *High* or *Off*. Press **OK**.
- 6 Press **Stop/Exit**.

## Automatic Daylight Savings Time

You can set the machine to change automatically for daylight savings time. It will reset itself forward one hour in the Spring and backward one hour in the Autumn. Make sure you have set the correct date and time in the *Date&Time* setting.

- 1 Press **Menu**.
- 2 Press ▲ or ▼ to choose *General Setup*. Press **OK**.
- 3 Press ▲ or ▼ to choose *Auto Daylight*.
- 4 Press ◀ or ▶ to choose *Off* (or *On*). Press **OK**.
- 5 Press **Stop/Exit**.

## Sleep Mode

You can choose how long the machine must be idle (from 1 to 60 minutes) before it goes into sleep mode. The timer will restart if any operation is carried out on the machine.

- 1 Press **Menu**.
- 2 Press **▲** or **▼** to choose General Setup.  
Press **OK**.
- 3 Press **▲** or **▼** to choose Sleep Mode.
- 4 Press **◀** or **▶** to choose 1Min, 2Mins, 3Mins, 5Mins, 10Mins, 30Mins or 60Mins which is the length of time the machine is idle before entering sleep mode.  
Press **OK**.
- 5 Press **Stop/Exit**.

## LCD screen

### LCD Contrast

You can adjust the LCD contrast for a sharper and more vivid display. If you are having difficulty reading the LCD, try changing the contrast setting.

- 1 Press **Menu**.
- 2 Press **▲** or **▼** to choose General Setup.  
Press **OK**.
- 3 Press **▲** or **▼** to choose LCD Settings.  
Press **OK**.
- 4 Press **▲** or **▼** to choose LCD Contrast.
- 5 Press **◀** or **▶** to choose Light, Med or Dark.  
Press **OK**.
- 6 Press **Stop/Exit**.

### Setting the backlight brightness

If you are having difficulty reading the LCD, try changing the brightness setting.

- 1 Press **Menu**.
- 2 Press **▲** or **▼** to choose General Setup.  
Press **OK**.
- 3 Press **▲** or **▼** to choose LCD Settings.  
Press **OK**.
- 4 Press **▲** or **▼** to choose Backlight.
- 5 Press **◀** or **▶** to choose Light, Med or Dark.  
Press **OK**.
- 6 Press **Stop/Exit**.

## Setting the Dim Timer for the backlight

---

You can set how long the LCD backlight stays on after the last key press.

- 1 Press **Menu**.
- 2 Press **▲** or **▼** to choose `General Setup`. Press **OK**.
- 3 Press **▲** or **▼** to choose `LCD Settings`. Press **OK**.
- 4 Press **▲** or **▼** to choose `Dim Timer`.
- 5 Press **◀** or **▶** to choose `10Secs`, `20Secs`, `30Secs` or `Off`. Press **OK**.
- 6 Press **Stop/Exit**.

## Setting the Wallpaper

---

You can change the wallpaper.

- 1 Press **Menu**.
- 2 Press **▲** or **▼** to choose `General Setup`. Press **OK**.
- 3 Press **▲** or **▼** to choose `LCD Settings`. Press **OK**.
- 4 Press **▲** or **▼** to choose `Wallpaper`. Press **OK**.
- 5 Press **▲** or **▼** to choose your wallpaper from the four available designs. Press **OK**.
- 6 Press **Stop/Exit**.

## Secure Function Lock

Secure Function Lock lets you restrict public access to certain machine functions (Fax, Copy, Scan, Print<sup>1</sup> and PCC).

This feature also prevents users from changing the default settings of the machine by limiting access to the menu settings.

Before using the security features you must first enter an administrator password.

Access to restricted operations can be enabled by creating a restricted user. Restricted users must enter a user password to use the machine.

Make a careful note of your password. If you forget it, please call your Brother dealer for service.

<sup>1</sup> Print includes PC-Fax Send as well as all print jobs.

### Note

- Only administrators can set limitations and make changes for each user.
- When Print is disabled, PC print jobs will be lost without notification.
- If Fax Tx is disabled, you cannot use any function in the Fax menu.
- Polling Receive is enabled only when the both Fax Tx and Fax Rx are enabled.

## Setting and changing the Administrator Password

### Setting the password

The password you set in these steps is for the administrator. This password is used to set up users and to turn Secure Function Lock on or off. (See *Setting up and changing restricted users* on page 35 and *Turning Secure Function Lock on/off* on page 36.)

- 1 Press **Menu**.
- 2 Press **▲** or **▼** to choose **General Setup**. Press **OK**.
- 3 Press **▲** or **▼** to choose **Function Lock**. Press **OK**.
- 4 Enter a four-digit number for the password using numbers 0-9. Press **OK**.
- 5 Re-enter the password when the LCD shows **Verify:**. Press **OK**.
- 6 Press **Stop/Exit**.

## Changing the password

- 1 Press **Menu**.
- 2 Press **▲** or **▼** to choose `General Setup`. Press **OK**.
- 3 Press **▲** or **▼** to choose `Function Lock`. Press **OK**.
- 4 Press **▲** or **▼** to choose `Set Password`. Press **OK**.
- 5 Enter the registered four-digit password. Press **OK**.
- 6 Enter a four-digit number for the new password. Press **OK**.
- 7 If the LCD shows `Verify:`, re-enter the new password. Press **OK**.
- 8 Press **Stop/Exit**.

## Setting up and changing the Public user

---

Public users do not need to enter a password. You can set up one Public user.

- 1 Press **Menu**.
- 2 Press **▲** or **▼** to choose `General Setup`. Press **OK**.
- 3 Press **▲** or **▼** to choose `Function Lock`. Press **OK**.
- 4 Press **▲** or **▼** to choose `Setup User`. Press **OK**.
- 5 Enter the administrator password. Press **OK**.
- 6 Press **▲** or **▼** to choose `Public`. Press **OK**.
- 7 Do one of the following:
  - To set up the Public user, press **◀** or **▶** to choose `Enable` or `Disable` for `Fax Tx`. After you have set `Fax Tx`, press **▲** or **▼** to choose the settings for `Fax Rx`, `Copy (Color)`, `Copy (B&W)`, `Scan`, `Print` and `PCC` by repeating this step. Press **OK**
  - To change the Public user setting, press **▲** or **▼** to choose the setting you want to change. Press **◀** or **▶** to choose `Enable` or `Disable`. Repeat this step until you finish changing settings. Press **OK**



### Note

---

If you disable PC Print and PhotoCapture printings (PCC) for Public users it will also disable those functions for all restricted users.

- 8 Press **Stop/Exit**.

## Setting up and changing restricted users

---

### Setting up restricted users

You can set up users with restrictions and a password. You can set up to 20 restricted users.

- 1 Press **Menu**.
- 2 Press **▲** or **▼** to choose `General Setup`. Press **OK**.
- 3 Press **▲** or **▼** to choose `Function Lock`. Press **OK**.
- 4 Press **▲** or **▼** to choose `Setup User`. Press **OK**.
- 5 Enter the administrator password. Press **OK**.
- 6 Press **▲** or **▼** to choose `User01`. Press **OK**.
- 7 Use the numeric keys to enter the user name. (See *Entering Text* on page 194.) Press **OK**.
- 8 Enter a four-digit password for the user. Press **OK**.
- 9 Press **◀** or **▶** to choose `Enable` or `Disable` for `Fax Tx`. Press **OK**.  
After you have set `Fax Tx`, press **▲** or **▼** and repeat this step for `Fax Rx`, `Copy (Color)`, `Copy (B&W)` and `Scan`.
- 10 Press **▲** or **▼** to choose `Exit`. Press **OK**.
- 11 Repeat 6 to 10 for entering each additional user and password.
- 12 Press **Stop/Exit**.



#### Note

You cannot use the same password as another user's password.

### Changing user name, password or settings for restricted users

- 1 Press **Menu**.
- 2 Press **▲** or **▼** to choose `General Setup`. Press **OK**.
- 3 Press **▲** or **▼** to choose `Function Lock`. Press **OK**.
- 4 Press **▲** or **▼** to choose `Setup User`. Press **OK**.
- 5 Enter the administrator password. Press **OK**.
- 6 Press **▲** or **▼** to choose the existing restricted user you want to change. Press **OK**.
- 7 Press **▲** or **▼** to choose `Change`. Press **OK**.
- 8 Do one of the following:
  - If you want to change the name press **Clear/Back**, and then enter the new name. (See *Entering Text* on page 194.) Press **OK**.
  - To leave the name unchanged press **OK**.
- 9 Enter a new four-digit password for this user. Press **OK**.
- 10 Press **◀** or **▶** to choose `Enable` or `Disable` for `Fax Tx`. Press **OK**.  
After you have set `Fax Tx`, press **▲** or **▼** and repeat this step for `Fax Rx`, `Copy (Color)`, `Copy (B&W)` and `Scan`.
- 11 Press **▲** or **▼** to choose `Exit`. Press **OK**.
- 12 Repeat 6 to 11 if you want to change more users and settings.
- 13 Press **Stop/Exit**.

## Reset existing restricted users

You can reset restricted users one by one.

- 1 Press **Menu**.
- 2 Press **▲** or **▼** to choose **General Setup**. Press **OK**.
- 3 Press **▲** or **▼** to choose **Function Lock**. Press **OK**.
- 4 Press **▲** or **▼** to choose **Setup User**. Press **OK**.
- 5 Enter the administrator password. Press **OK**.
- 6 Press **▲** or **▼** to choose the existing restricted user you want to reset. Press **OK**.
- 7 Press **▲** or **▼** to choose **Reset**. Press **OK**.
- 8 Press **1** to choose **Yes**.
- 9 Do one of the following:
  - Set a new restricted user. (See *Setting up restricted users* on page 35.)
  - If you do not want to set a new restricted user, go to step 10.
- 10 Repeat 6 to 9 if you want to reset more users.
- 11 Press **Stop/Exit**.

## Turning Secure Function Lock on/off



### Note

If you enter the wrong password, the LCD will show **Wrong Password**. Re-enter the correct password.

### Turning Secure Function Lock on

- 1 Press **Menu**.
- 2 Press **▲** or **▼** to choose **General Setup**. Press **OK**.
- 3 Press **▲** or **▼** to choose **Function Lock**. Press **OK**.
- 4 Press **▲** or **▼** to choose **Lock Off→On**. Press **OK**.
- 5 Enter your four-digit administrator password. Press **OK**.

### Turning Secure Function Lock off

- 1 Press **Menu**.
- 2 Press **▲** or **▼** to choose **Lock On→Off**. Press **OK**.
- 3 Enter your four-digit administrator password. Press **OK**.

## Switching users

---

This setting allows a restricted user to log on the machine when Secure Function Lock is turned on.

- 1 Hold down **Shift** as you press **\***. Or, press **Menu**. Then press **▲** or **▼** to choose `Change User` and press **OK**.
- 2 Press **▲** or **▼** to choose your user name. Press **OK**.
- 3 Enter your four-digit password. Press **OK**.

## Changing to the Public mode

---

- 1 Press **Menu**.
- 2 Press **▲** or **▼** to choose `Go to Public`. Press **OK**.



### Note

---

After a restricted user has finished using the machine, it will return to the Public setting within the same time as the Mode Timer setting. (See *Mode Timer* on page 26.)

---

## Reset all users

---

You can reset all settings and passwords for the Public user and all restricted users.

- 1 Press **Menu**.
- 2 Press **▲** or **▼** to choose `General Setup`. Press **OK**.
- 3 Press **▲** or **▼** to choose `Function Lock`. Press **OK**.
- 4 Press **▲** or **▼** to choose `Reset All Users`. Press **OK**.
- 5 Enter your four-digit administrator password. Press **OK**.
- 6 Press **1** to reset.
- 7 Press **Stop/Exit**.





# Fax

---

<b>Sending a Fax</b>	40
<b>Receiving a Fax</b>	49
<b>Telephone and External devices</b>	64
<b>Dialling and storing numbers</b>	72
<b>Printing Reports</b>	82
<b>Polling</b>	84

# 5

## Sending a Fax

### Entering Fax mode

When you want to send a fax, or change fax send or receive settings, press the

 (**Fax**) key to illuminate it in blue.

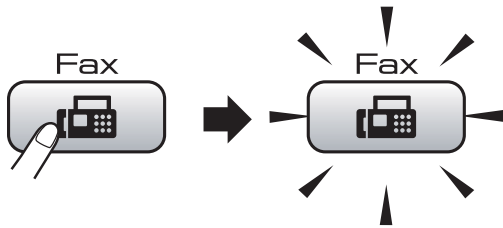

The LCD shows:

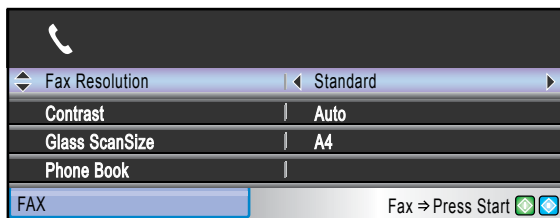

Press **▲** or **▼** to scroll through the **Fax** key options. Some functions are only available when sending monochrome faxes.

- Fax Resolution (See page 45.)
- Contrast (See page 45.)
- Glass ScanSize  
(MFC-5890CN: See page 41.)  
(MFC-6490CW: See page 42.)
- Phone Book (See page 72.)
- Outgoing Call (See page 73.)
- Caller ID hist. (See page 74.)
- Broadcasting (See page 43.)
- Delayed Fax (See page 46.)
- Batch TX (See page 47.)
- Real Time TX (See page 46.)
- Polled TX (See page 86.)
- Polling RX (See page 84.)
- Overseas Mode (See page 46.)
- Set New Default (See page 47.)
- Factory Reset (See page 47.)

When the option you want is highlighted, press **OK**.

### Faxing from the ADF

- 1 Press  (**Fax**).
- 2 Place the document face up in the ADF. (See *Using the ADF* on page 22.)
- 3 Enter the fax number using the dial pad, One Touch, Speed Dial or Search.



#### Note

You can preview a fax message before sending it by pressing **Fax Preview**. (See *How to preview an outgoing fax* on page 42.)

- 4 Press **Mono Start** or **Colour Start**. The machine starts scanning the document.



#### Note

- To cancel, press **Stop/Exit**.
- If you send a mono fax when the memory is full it will be sent in real time.
- You can send colour faxes up to A4 in size.

## Faxing from the scanner glass

You can use the scanner glass to fax pages of a book one at a time. The documents can be up to A3 size for MFC-6490CW, and A4 size for MFC-5890CN.

You cannot send colour faxes with multiple pages.

### Note

- Since you can only scan one page at a time, it is easier to use the ADF if you are sending a multiple page document.
- (MFC-6490CW only)  
You can send colour faxes up to A4 in size.

- 1 Press  (**Fax**).
- 2 Load your document face down on the scanner glass. (See *Using the scanner glass* on page 23.)
- 3 Enter the fax number using the dial pad, One Touch, Speed Dial or Search.

### Note

You can preview a fax message before sending it by pressing **Fax Preview**. For details, see *How to preview an outgoing fax* on page 42.

- 4 Press **Mono Start** or **Colour Start**.
  - If you press **Mono Start**, the machine starts scanning the first page. Go to step 5.
  - If you press **Colour Start**, the machine starts sending the document.

- 5 Do one of the following:
  - To send a single page, press **2** to choose **No** (or press **Mono Start** again).  
The machine starts sending the document.
  - To send more than one page, press **1** to choose **Yes** and go to step 6.
- 6 Place the next page on the scanner glass. Press **OK**.  
The machine starts scanning the page. (Repeat steps 5 and 6 for each additional page.)

## Setting scanner glass size for faxing (MFC-5890CN only)

When documents are Letter size, you need to set scan size to Letter. If you do not, the side portion of the faxes will be missing.

- 1 Press  (**Fax**).
- 2 Press **▲** or **▼** to choose **Glass ScanSize**.
- 3 Press **◀** or **▶** to choose **Letter** (or **A4**). Press **OK**.

### Note

- You can save the setting you use most often by setting it as default. (See *Setting your changes as a new default* on page 47.)
- This setting is only available for sending documents from the scanner glass.

## Setting scanner glass size for faxing (MFC-6490CW only)

To fax a A3, Letter, Legal or Ledger size document from the scanner glass, you need to change the glass scan size setting.

- 1 Press  (**Fax**).
- 2 Press ▲ or ▼ to choose **Glass ScanSize**.
- 3 Press ◀ or ▶ to choose **A4, A3, Letter, Legal or Ledger**.



### Note

You can save the setting you use most often by setting it as default. (See *Setting your changes as a new default* on page 47.)

## Colour fax transmission





Your machine can send a colour fax to machines that support this feature.

Colour faxes cannot be stored in the memory. When you send a colour fax, the machine will send it in real time (even if **Real Time TX** is set to **Off**).

## How to preview an outgoing fax

You can preview a fax message before you send it. You must set the **Real Time Transmission** and **Polling RX** to off before you use this feature.

- 1 Press  (**Fax**).
- 2 Load the document.
- 3 Enter the fax number using the dial pad, **One Touch** or **Speed Dial**.
- 4 Press **Fax Preview**.  
The machine starts scanning the document and the outgoing fax appears on the LCD. When the fax is open the control panel keys will perform the operations shown below.

Key	Description
	Enlarge the fax.
	Reduce the fax.
▲ or ▼	Scroll vertically.
◀ or ▶	Scroll horizontally.
	Rotate the fax clockwise.
	Go back to the previous page.
	Go to the next page.

- 5 Press **Mono Start**.



### Note

The fax message in the memory will be sent and then erased when you press **Mono Start**.

## Cancelling a fax in progress

If you want to cancel a fax while the machine is scanning, dialling or sending, press **Stop/Exit**.

## Broadcasting (Monochrome only)

Broadcasting is when the same fax message is automatically sent to more than one fax number. You can include Groups, One Touch, Speed Dial numbers and up to 50 manually dialled numbers in the same broadcast.

After the broadcast is finished, a Broadcast Report will be printed.

- 1 Press  (**Fax**).
- 2 Load your document.
- 3 Press **▲** or **▼** to choose `Broadcasting`. Press **OK**.
- 4 You can add numbers to the broadcast in the following ways:
  - Press **▲** or **▼** to choose `Add Number` and enter a number using a dial pad. Press **OK**.
  - Press **▲** or **▼** to choose `Phone Book` and **OK**. Press **▲** or **▼** to choose `Alphabetical Order` or `Numerical Order` and **OK**. Press **▲** or **▼** to select a number and **OK**.



### Note

One Touch Dial locations begin with **\***.  
Speed Dial locations begin with **#**.

- 5 After you have entered all the fax numbers by repeating step 4, press **▲** or **▼** to choose `Complete`. Press **OK**.

- 6 Press **Mono Start**.



### Note

- If you did not use up any of the numbers for Groups, you can 'broadcast' faxes to as many as 216 (MFC-5890CN) or 256 (MFC-6490CW) different numbers.
- The available memory will vary depending on the types of jobs in the memory and the number of locations used for broadcasting. If you broadcast to the maximum numbers available, you will not be able to use dual access and delayed fax.
- If the memory is full, press **Stop/Exit** to stop the job. If more than one page has been scanned, press **Mono Start** to send the portion that is in the memory.

## Cancelling a Broadcast in progress

- 1 Press **Menu**.
- 2 Press **▲** or **▼** to choose **Fax**. Press **OK**.
- 3 Press **▲** or **▼** to choose **Remaining Jobs**. Press **OK**. The LCD will show the fax number being dialled and the Broadcast job number.
- 4 Press **OK**. The LCD will ask you the following message:  
Cancel Job?  
Yes → Press 1  
No → Press 2
- 5 Press **1** to cancel the number being dialled. The LCD will then show the Broadcast job number.
- 6 Press **OK**. The LCD will ask you the following message:  
Cancel Job?  
Yes → Press 1  
No → Press 2
- 7 Press **1** to cancel the Broadcast.
- 8 Press **Stop/Exit**.

## Additional sending operations

### Sending faxes using multiple settings

When you send a fax you can choose any combination of these settings: resolution, contrast, glass scan size, overseas mode, delayed fax timer, polling transmission and real time transmission.

- 1 Press  (**Fax**). The LCD shows:

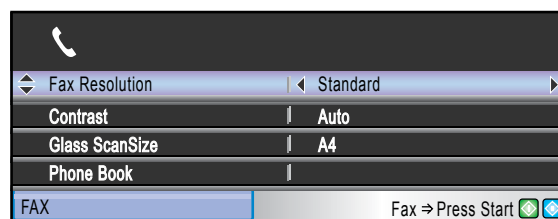

- 2 Press **▲** or **▼** to choose a setting you want to change.
- 3 Press **◀** or **▶** to choose an option.
- 4 Go back to 2 to change more settings.



#### Note

- Most settings are temporary and the machine returns to its default settings after you send a fax.
- You can save some of the settings you use most often by setting them as default. These settings will stay until you change them again. (See *Setting your changes as a new default* on page 47.)

## Contrast

If your document is very light or very dark, you may want to change the contrast. For most documents the factory setting `Auto` can be used. It automatically chooses the suitable contrast for your document.

Use `Light` when sending a light document.

Use `Dark` when sending a dark document.

- 1 Press  (**Fax**).
- 2 Press **▲** or **▼** to choose `Contrast`.
- 3 Press **◀** or **▶** to choose `Auto`, `Light` or `Dark`.  
Press **OK**.



### Note

Even if you choose `Light` or `Dark`, the machine will send the fax using the `Auto` setting in any of the following conditions:

- When you send a colour fax.
- When you choose `Photo` as the Fax Resolution.

## Changing fax resolution

The quality of a fax can be improved by changing the fax resolution.

- 1 Press  (**Fax**).
- 2 Press **▲** or **▼** to choose `Fax Resolution`.
- 3 Press **◀** or **▶** to choose the resolution you want.  
Press **OK**.



### Note

You can choose four different resolution settings for monochrome faxes and two for colour.

Monochrome	
Standard	Suitable for most typed documents.
Fine	Good for small print and transmits a little slower than Standard resolution.
S.Fine	Good for small print or artwork and transmits slower than Fine resolution.
Photo	Use when the document has varying shades of grey or is a photograph. This has the slowest transmission.

Colour	
Standard	Suitable for most typed documents.
Fine	Use when the document is a photograph. The transmission time is slower than Standard resolution.

If you choose `S.Fine` or `Photo` and then use the **Colour Start** key to send a fax, the machine will send the fax using the `Fine` setting.

## Dual access (Monochrome only)

You can dial a number and start scanning the fax into memory—even when the machine is sending from memory, receiving faxes or printing PC data. The LCD shows the new job number and available memory.

The number of pages you can scan into the memory will vary depending on the data that is printed on them.



### Note

If the **Out of Memory** message appears while scanning documents, press **Stop/Exit** to cancel or **Mono Start** to send the scanned pages.

## Real time transmission

When you are sending a fax, the machine will scan the documents into the memory before sending. Then, as soon as the telephone line is free, the machine will start dialling and sending.

If the memory is full and you are sending a black & white fax from the ADF, the machine will send the document in real time (even if **Real Time TX** is set to **Off**).

Sometimes, you may want to send an important document immediately, without waiting for memory transmission. You can turn on **Real Time TX**.

- 1 Press  (**Fax**).
- 2 Press ▲ or ▼ to choose **Real Time TX**.
- 3 Press ◀ or ▶ to choose **On** (or **Off**). Press **OK**.



### Note

In real time transmission, the automatic redial feature does not work when using the scanner glass.

## Overseas Mode

If you are having difficulty sending a fax overseas due to possible interference on the telephone line, we recommend that you turn on the **Overseas mode**. After you send a fax using this feature, the feature will turn itself off.

- 1 Press  (**Fax**).
- 2 Load your document.
- 3 Press ▲ or ▼ to choose **Overseas Mode**.
- 4 Press ◀ or ▶ to choose **On** (or **Off**). Press **OK**.

## Delayed Faxing (Monochrome only)

During the day you can store up to 50 faxes in the memory to be sent within 24-hours. These faxes will be sent at the time of day you enter in step 5.

- 1 Press  (**Fax**).
- 2 Load your document.
- 3 Press ▲ or ▼ to choose **Delayed Fax**.
- 4 Press ◀ or ▶ to choose **On**. Press **OK**.
- 5 Enter the time you want the fax to be sent (in 24-hour format). (For example, enter 19:45 for 7:45 PM.) Press **OK**.



### Note

The number of pages you can scan into the memory depends on the amount of data that is printed on each page.

## Delayed Batch Transmission (Monochrome only)

Before sending the delayed faxes, your machine will help you economize by sorting all the faxes in the memory by destination and scheduled time. All delayed faxes that are scheduled to be sent at the same time to the same fax number will be sent as one fax to save transmission time.

- 1 Press  (Fax).
- 2 Press ▲ or ▼ to choose `Batch TX`.
- 3 Press ◀ or ▶ to choose `On`. Press **OK**.
- 4 Press **Stop/Exit**.

## Checking and cancelling waiting jobs

You can check which jobs are still waiting in the memory to be sent and cancel a job. (If there are no jobs, the LCD shows `No Jobs Waiting`.)

- 1 Press **Menu**.
- 2 Press ▲ or ▼ to choose `Fax`. Press **OK**.
- 3 Press ▲ or ▼ to choose `Remaining Jobs`. Press **OK**. Any waiting jobs appear on the LCD.
- 4 Press ▲ or ▼ to scroll through the jobs and choose the job you want to cancel. Press **OK**.
- 5 Do one of the following:
  - To cancel, press **1** to choose `Yes`.  
If you want to cancel another job go to step 4.
  - To exit without cancelling, press **2** to choose `No`.
- 6 When you have finished, press **Stop/Exit**.

## Setting your changes as a new default

You can save the fax settings for `Fax Resolution`, `Contrast`, `Glass ScanSize` and `Real Time TX` you use most often by setting them as default. These settings will stay until you change them again.

- 1 Press  (Fax).
- 2 Press ▲ or ▼ to choose the menu option that you want to change. Press ◀ or ▶ to choose your new setting. Repeat this step for each setting you want to change.
- 3 After changing the last setting, press ▲ or ▼ to choose `Set New Default`. Press **OK**.
- 4 Press **1** to choose `Yes`.
- 5 Press **Stop/Exit**.

## Restoring all settings to the factory settings

You can restore all the settings you have changed to the factory settings. These settings will stay until you change them again.

- 1 Press  (Fax).
- 2 Press ▲ or ▼ to choose `Factory Reset`. Press **OK**.
- 3 Press **1** to choose `Yes`.
- 4 Press **Stop/Exit**.

## Sending a fax manually

---

Manual transmission lets you hear the dialling, ringing and fax-receiving tones while sending a fax.

- 1 Press  (**Fax**).
- 2 Load your document.
- 3 To listen for a dial tone pick up the handset of an external telephone.
- 4 Dial the fax number.
- 5 When you hear the fax tone, press **Mono Start** or **Colour Start**.  
If you are using the scanner glass press **1** on the machine to send a fax.
- 6 Replace the handset.

## Out of Memory message

---

If you get an `Out of Memory` message while scanning the first page of a fax, press **Stop/Exit** to cancel the fax.

If you get an `Out of Memory` message while scanning a subsequent page, you will have the option to press **Mono Start** or **Colour Start** to send the pages scanned so far, or to press **Stop/Exit** to cancel the operation.

### **Note**

---

If you do not want to delete your stored faxes to clear the memory, you can change the setting to send the fax in real time. (See *Real time transmission* on page 46.)

---

# 6

## Receiving a Fax

### Receive modes

You must choose a receive mode depending on the external devices and telephone services you have on your line.

### Choose the Receive Mode

By default, your machine will automatically receive any faxes that are sent to it. The diagram below will help you choose the correct mode.

For more detailed information on the receive modes, see *Using receive modes* on page 50.

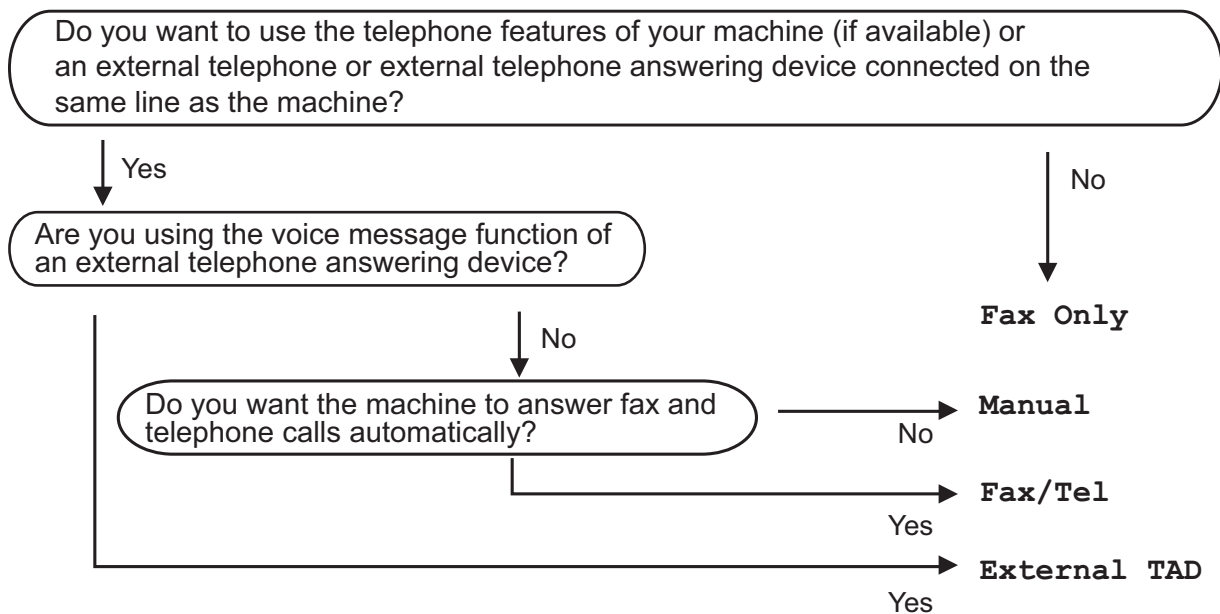

To set a receive mode follow the instructions below.

- 1 Press **Menu**.
- 2 Press **▲** or **▼** to choose *Initial Setup*. Press **OK**.
- 3 Press **▲** or **▼** to choose *Receive Mode*.
- 4 Press **◀** or **▶** to choose *Fax Only*, *Fax/Tel*, *External TAD* or *Manual*. Press **OK**.
- 5 Press **Stop/Exit**.  
The LCD will display the current receive mode.

## Using receive modes

Some receive modes answer automatically (**Fax Only** and **Fax/Tel**). You may want to change the ring delay before using these modes. (See *Ring Delay* on page 51.)

### Fax only

---

Fax only mode will automatically answer every call as a fax call.

### Fax/Tel

---

Fax/Tel mode helps you automatically manage incoming calls, by recognizing whether they are fax or voice calls and dealing with them in one of the following ways:

- Faxes will be automatically received.
- Voice calls will start the F/T ring to tell you to pick up the line. The F/T ring is a fast double ring made by your machine.

(Also see *F/T Ring Time (Fax/Tel mode only)* on page 51 and *Ring Delay* on page 51.)

### Manual

---

Manual mode turns off all automatic answering functions unless you are using the BT Call Sign feature.

To receive a fax in manual mode lift the handset of an external telephone. When you hear fax tones (short repeating beeps), press **Mono Start** or **Colour Start** and choose **Receive**. You can also use the Fax Detect feature to receive faxes by lifting a handset on the same line as the machine.

(Also see *Fax Detect* on page 52.)

## External TAD

---

External TAD mode lets an external answering device manage your incoming calls. Incoming calls will be dealt with in one of the following ways:

- Faxes will be automatically received.
- Voice callers can record a message on the external TAD.

(For more information see *Connecting an external TAD (telephone answering device)* on page 67.)

## Receive mode settings

### Ring Delay

The Ring Delay sets the number of times the machine rings before it answers in `Fax Only` or `Fax/Tel` mode. If you have external or extension telephones on the same line as the machine choose the maximum number of rings.

(See *Operation from extension telephones* on page 69 and *Fax Detect* on page 52.)

- 1 Press **Menu**.
- 2 Press **▲** or **▼** to choose `Fax`. Press **OK**.
- 3 Press **▲** or **▼** to choose `Setup Receive`. Press **OK**.
- 4 Press **▲** or **▼** to choose `Ring Delay`.
- 5 Press **◀** or **▶** to choose how many times the line rings before the machine answers. Press **OK**.  
If you choose 0, the line will not ring at all.
- 6 Press **Stop/Exit**.

### F/T Ring Time (Fax/Tel mode only)

When somebody calls your machine, you and your caller will hear the normal telephone ring sound. The number of rings is set by the ring delay setting.

If the call is a fax, then your machine will receive it; however, if it is a voice call the machine will sound the F/T ring (a fast double-ring) for the time you have set in the F/T ring time setting. If you hear the F/T ring it means that you have a voice caller on the line.

Because the F/T ring is made by the machine, extension and external telephones will *not* ring; however, you can still answer the call on any telephone. (For more information see *Using remote codes* on page 70.)

- 1 Press **Menu**.
- 2 Press **▲** or **▼** to choose `Fax`. Press **OK**.
- 3 Press **▲** or **▼** to choose `Setup Receive`. Press **OK**.
- 4 Press **▲** or **▼** to choose `F/T Ring Time`.
- 5 Press **◀** or **▶** to choose how long the machine will ring to alert you that you have a voice call (20, 30, 40 or 70 seconds). Press **OK**.
- 6 Press **Stop/Exit**.



#### Note

Even if the caller hangs up during the pseudo/double-ringing, the machine will continue to ring for the set time.

## Fax Detect

---

### If Fax Detect is On:

The machine receives a fax call automatically, even if you answer the call. When you see *Receiving* on the LCD or when you hear “chirps” through the handset you are using, just replace the handset. Your machine will do the rest.

### If Fax Detect is Off:

If you are at the machine and answer a fax call by lifting the handset, press **Mono Start** or **Colour Start**, then press **2** to receive the fax.

If you answered at an extension telephone, press \* **5 1**. (See *Operation from extension telephones* on page 69.)



### Note

---

- If this feature is set to *On*, but your machine does not connect a fax call when you lift an extension or external telephone handset, press the remote activation code \* **5 1**.
- If you send faxes from a computer on the same telephone line and the machine intercepts them, set Fax Detect to *Off*.

- 1 Press **Menu**.
- 2 Press ▲ or ▼ to choose *Fax*. Press **OK**.
- 3 Press ▲ or ▼ to choose *Setup Receive*. Press **OK**.
- 4 Press ▲ or ▼ to choose *Fax Detect*.
- 5 Press ◀ or ▶ to choose *On* (or *Off*). Press **OK**.
- 6 Press **Stop/Exit**.

## Additional receiving operations

### Printing a reduced incoming fax

---

If you choose *On*, the machine automatically reduces each page of an incoming fax to fit on one page of A4, Letter or Legal size paper. The machine calculates the reduction ratio by using the page size of the fax and your Paper Size setting. (See *Paper Size and Type (MFC-5890CN only)* on page 26 or *Paper Size and Type (MFC-6490CW only)* on page 27.)

- 1 Press **Menu**.
- 2 Press ▲ or ▼ to choose *Fax*. Press **OK**.
- 3 Press ▲ or ▼ to choose *Setup Receive*. Press **OK**.
- 4 Press ▲ or ▼ to choose *Auto Reduction*.
- 5 Press ◀ or ▶ to choose *On* (or *Off*). Press **OK**.
- 6 Press **Stop/Exit**.

## Setting Receiving Priority

If a A3 Colour fax is sent to your machine, your machine will receive either a A3 mono fax or a A4 Colour fax depending on the Receiving Priority setting. If you choose `Mono (Max. A3)`, you will receive a A3 mono fax. If you choose `Colour (Max. A4)`, you will receive a A4 Colour fax.

### Note

The default setting is `Mono (Max. A3)`, so the machine cannot receive A4 colour fax by default.

Receiving Priority	Document Sent		Document Received	Fax Preview	Storage OFF	Memory Receive (On)	
						Fax Storage Fax Forward	PC-FAX
<b>CLR (Max. A4)</b>	Colour	A4	Colour A4	N/A (Colour Printout)	(Colour Printout)	N/A (Colour Printout)	N/A (Colour Printout)
		A3	Colour A4 <sup>1</sup> (Reduced)				
	Mono	A4	Mono A4	Available	(Mono Printout)	Available	Available (Up to A4 size)
		A3	Mono A4 <sup>1</sup> (Reduced)				
<b>Mono (Max. A3)</b>	Colour	A4	Mono A4 <sup>1</sup>				
		A3	Mono A3 <sup>1</sup>				
	Mono	A4	Mono A4				
		A3	Mono A3				

<sup>1</sup> These results may vary depending on the sending machine's ability.

- 1 Press **Menu**.
- 2 Press **▲** or **▼** to choose `Fax`. Press **OK**.
- 3 Press **▲** or **▼** to choose `Setup Receive`. Press **OK**.
- 4 Press **▲** or **▼** to choose `Mono/Colour`.
- 5 Press **◀** or **▶** to choose `Mono (Max. A3)` or `Colour (Max. A4)`. Press **OK**.
- 6 Press **Stop/Exit**.

## Printing a fax from the memory

---

If you have chosen fax storage, you can still print a fax from the memory when you are at your machine. If you have chosen **Fax Preview**, see *Fax Preview (Monochrome only)* on page 58.

- 1 Press **Menu**.
- 2 Press **▲** or **▼** to choose **Fax**. Press **OK**.
- 3 Press **▲** or **▼** to choose **Print Document**. Press **OK**.
- 4 Press **Mono Start**.
- 5 Press **Stop/Exit**.



### Note

---

When you print a fax from the memory, the fax data will be erased.

## Out of Paper Reception

---

As soon as the paper tray becomes empty during fax reception, the LCD shows **No Paper Fed**. Put some paper in the paper tray. (See *Loading paper and other print media* on page 9.)

The machine will carry on receiving the fax, with the remaining pages being stored in memory, if enough memory is available.

Further incoming faxes will also be stored into memory until the memory is full. When the memory is full the machine will stop automatically answering calls. To print the faxes, put fresh paper in the tray.

## Memory Receive (Monochrome only)

You can only use one Memory Receive operation at a time:

- Fax Forwarding
- Fax Storage
- PC Fax Receive
- Off

You can change your selection at any time. If received faxes are still in the machine's memory when you change the Memory Receive operations, a message will appear on the LCD. (See *Changing Memory Receive Operations* on page 58.)



### Note

---

When you receive a colour fax, the machine will treat the data as a colour or monochrome fax depending on the Receive Priority setting. (See *Setting Receiving Priority* on page 53.)

## Fax Forwarding

When you choose Fax Forward, your machine stores the received fax in the memory. The machine will then dial the fax number you have programmed and forward the fax message.

- 1 Press **Menu**.
- 2 Press **▲** or **▼** to choose `Fax`. Press **OK**.
- 3 Press **▲** or **▼** to choose `Setup Receive`. Press **OK**.
- 4 Press **▲** or **▼** to choose `Memory Receive`. Press **OK**.
- 5 Press **▲** or **▼** to choose `Fax Forward`. Press **OK**.
- 6 Enter the forwarding number (up to 20 digits). Press **OK**.
- 7 Press **▲** or **▼** to choose `Backup Print:On` or `Backup Print:Off`. Press **OK**.



### Note

- If you choose `Backup Print:On`, the machine will also print the fax at your machine so you will have a copy. This is a safety feature in case there is a power failure before the fax is forwarded or a problem at the receiving machine. This `Backup Print:On` feature will not work if Fax Preview is on.
- The machine can store faxes approximately 24 hours if there is a power failure.

- 8 Press **Stop/Exit**.

## Fax Storage

If you choose Fax Storage, your machine stores the received fax in the memory. You will be able to retrieve fax messages from another location using the remote retrieval commands.

If you have set Fax Storage, a backup copy will automatically be printed at the machine.

- 1 Press **Menu**.
- 2 Press **▲** or **▼** to choose `Fax`. Press **OK**.
- 3 Press **▲** or **▼** to choose `Setup Receive`. Press **OK**.
- 4 Press **▲** or **▼** to choose `Memory Receive`. Press **OK**.
- 5 Press **▲** or **▼** to choose `Fax Storage`. Press **OK**.
- 6 Press **Stop/Exit**.

## PC Fax Receive

If you turn on the PC-Fax Receive feature your machine will store received faxes in memory and send them to your PC automatically. You can then use your PC to view and store these faxes.

Even if you have turned off your PC (at night or on the weekend, for example), your machine will receive and store your faxes in its memory. The number of received faxes that are stored in the memory will appear at the bottom left side of the LCD.

When you start your PC and the PC-FAX Receiving software runs, your machine transfers your faxes to your PC automatically.

To transfer the received faxes to your PC you must have the PC-FAX Receiving software running on your PC. (For details, see *PC-FAX receiving* in the Software User's Guide on the CD-ROM.)

If you choose `Backup Print:On` the machine will also print the fax.

- 1 Press **Menu**.
- 2 Press **▲** or **▼** to choose `Fax`. Press **OK**.
- 3 Press **▲** or **▼** to choose `Setup Receive`. Press **OK**.
- 4 Press **▲** or **▼** to choose `Memory Receive`. Press **OK**.
- 5 Press **▲** or **▼** to choose `PC Fax Receive`. Press **OK**.
- 6 Press **▲** or **▼** to choose `<USB>` or the PC you want to receive. Press **OK**.
- 7 Press **▲** or **▼** to choose `Backup Print:On` or `Backup Print:Off`. Press **OK**.

- 8 Press **Stop/Exit**.



### Note

- PC Fax Receive is not supported in the Mac OS®.
- Before you can set up PC Fax Receive you must install the MFL-Pro Suite software on your PC. Make sure your PC is connected and turned on. (For details see *PC-FAX receiving* in the Software User's Guide on the CD-ROM.)
- In the event of a power failure, the machine will store your faxes in the memory for approximately 24 hours. However, if you choose `Backup Print:On` the machine will print the fax, so you will have a copy if there is a power failure before it is sent to the PC.
- If you get an error message and the machine cannot print the faxes in memory, you can use this setting to transfer your faxes to your PC. (For details, see *Error and Maintenance messages* on page 144.)

## Changing the destination PC

---

- 1 Press **Menu**.
- 2 Press **▲** or **▼** to choose **Fax**.  
Press **OK**.
- 3 Press **▲** or **▼** to choose  
**Setup Receive**.  
Press **OK**.
- 4 Press **▲** or **▼** to choose  
**Memory Receive**.  
Press **OK**.
- 5 Press **▲** or **▼** to choose  
**PC Fax Receive**.  
Press **OK**.
- 6 Press **▲** or **▼** to choose **Change**.  
Press **OK**.
- 7 Press **▲** or **▼** to choose **<USB>** or the PC  
you want to receive.  
Press **OK**.
- 8 Press **▲** or **▼** to choose  
**Backup Print:On** or  
**Backup Print:Off**.  
Press **OK**.
- 9 Press **Stop/Exit**.

## Turning off Memory Receive Operations

---

- 1 Press **Menu**.
- 2 Press **▲** or **▼** to choose **Fax**.  
Press **OK**.
- 3 Press **▲** or **▼** to choose  
**Setup Receive**.  
Press **OK**.
- 4 Press **▲** or **▼** to choose  
**Memory Receive**.  
Press **OK**.
- 5 Press **▲** or **▼** to choose **Off**.  
Press **OK**.
- 6 Press **Stop/Exit**.



### Note

---

The LCD will give you more options if there are received faxes still in your machine's memory. (See *Changing Memory Receive Operations* on page 58.)

---

## Changing Memory Receive Operations

---

If received faxes remain in your machine's memory when you change the Memory Receive Operations, the LCD will ask you one of the following questions:

■ Erase All Doc?

Yes → Press 1

No → Press 2

■ Print All Fax?

Yes → Press 1

No → Press 2

- If you press **1**, faxes in the memory will be erased or printed before the setting changes. If a backup copy has already been printed it will not be printed again.
- If you press **2**, faxes in the memory will not be erased or printed and the setting will be unchanged.

If received faxes are left in the machine's memory when you change to PC Fax Receive from another option [Fax Forward or Fax Storage], press ▲ or ▼ to choose the PC.

The LCD will ask you the following question:

■ Send Fax to PC?

Yes → Press 1

No → Press 2

- If you press **1**, faxes in the memory will be sent to your PC before the setting changes. You will be asked if you want to turn on Backup Print. (For detail, see *PC Fax Receive* on page 56.)
- If you press **2**, faxes in the memory will not be erased or transferred to your PC and the setting will be unchanged.

## Fax Preview (Monochrome only)

### How to preview a received fax

---

You can view received faxes on the LCD by pressing the **Fax Preview** key. When the machine is in Ready mode, a popup message will appear on the LCD to alert you of new faxes.

### Setting Fax Preview

- 1 Press **Fax Preview**.
- 2 Press **1** to choose **Yes**.  
LCD asks you again to make sure that faxes will not be printed.  
Press **1** to choose **OK**.



### Note

---

- When you receive colour fax, the machine will treat the data as colour fax or monochrome fax depend on your setting for Memory Receive. (See *Setting Receiving Priority* on page 53.)
  - When Fax Preview is turned On, a backup copy of received faxes will not be printed, even if you have set Backup Print On.
-

## Using Fax Preview

When you receive a fax, you will see the pop-up message on the LCD. (For example:

New Fax(es): 02)

### 1 Press **Fax Preview**.

You can see the new fax list.



#### Note

- (MFC-6490CW)  
If you receive a fax containing multiple paper sizes (for example, a page of A4 data and a page of A3 data), the machine may create and store a file for each paper size. The LCD may show that more than one fax job has been received.
- You can also see your old fax list by pressing \*. Press # to go back to your new fax list.

### 2 Press ▲ or ▼ to choose the fax you want to see.

Press **OK**.



#### Note

- If your fax is large there may be a delay before it is displayed on the LCD.
- The LCD will show the current page number and total pages of the fax message. When your fax message is over 99 pages the total number of pages will be shown as "XX".

### 3 Press **Stop/Exit**.

When a fax is open the control panel keys will perform the operations shown below.

Key	Description
	Enlarge the fax.
	Reduce the fax.
	Scroll vertically.
	Scroll horizontally.
	Rotate the fax clockwise.
	Delete the fax. Press <b>1</b> to confirm.
	Go back to the previous page.
	Go to the next page.
	Go to the next step. (Print, Back and Exit are available.)
	Go back to the fax list.
 <b>Mono Start</b>	Print the fax. Do one of the following: <ul style="list-style-type: none"> <li>■ Press <b>1</b> to print the whole message.</li> <li>■ Press <b>2</b> to print only the displayed page.</li> <li>■ Press <b>3</b> to print from the displayed page.</li> </ul> (After printing, you can choose to delete or re-print the fax.)

## How to delete all faxes in the list

- 1 Press **Fax Preview**.
- 2 Press **▲** or **▼** to choose `Delete All`. Press **OK**. Press **1** to confirm.
- 3 Press **Stop/Exit**.

## How to print all faxes in the list

- 1 Press **Fax Preview**.
- 2 Press **▲** or **▼** to choose `Print All`. Press **OK**.
- 3 Press **Stop/Exit**.

## Changing the settings to turn off Fax Preview

- 1 Press **Fax Preview**.
- 2 Press **▲** or **▼** to choose `Fax Preview → Off`. Press **OK**.
- 3 Press **1** to choose `Yes`.
- 4 Do one of the following:
  - If you do not want to print the stored faxes, press **1**. The machine asks you to confirm the deletion of the stored faxes. Press **1** to confirm.
  - If you want to print all the stored faxes, press **2**.
  - If you want to cancel the setting, press **3**. Press **Stop/Exit**.

## Remote Retrieval

You can call your machine from any touch tone telephone or fax machine, then use the remote access code and remote commands to retrieve fax messages.

## Setting a Remote Access Code

The remote access code lets you access the remote retrieval features when you are away from your machine. Before you can use the remote access and retrieval features, you have to set up your own code. The factory default code is the inactive code (---\*).

- 1 Press **Menu**.
- 2 Press **▲** or **▼** to choose `Fax`. Press **OK**.
- 3 Press **▲** or **▼** to choose `Remote Access`.
- 4 Enter a three-digit code using numbers **0-9**, **\***, or **#**. Press **OK**. (The preset `*` cannot be changed.)



### Note

Do not use the same code as your Remote Activation Code (**\* 5 1**) or Remote Deactivation Code (**# 5 1**). (See *Operation from extension telephones* on page 69.)

- 5 Press **Stop/Exit**.



### Note

You can change your code at any time by entering a new one. If you want to make your code inactive, press **Clear/Back** in step 4 to restore the inactive setting (---\*) and press **OK**.

## Using your Remote Access Code

---

- 1 Dial your fax number from a touch tone telephone or another fax machine.
- 2 When your machine answers, enter your remote access code (3 digits followed by \*) at once.
- 3 The machine signals if it has received messages:
  - **1 long beep — Fax messages**
  - **No beeps — No messages**
- 4 When the machine gives two short beeps, enter a command.  
The machine will hang up if you wait longer than 30 seconds to enter a command.  
The machine will beep three times if you enter an invalid command.
- 5 Press **9 0** to stop Remote Access when you have finished.
- 6 Hang up.



### Note

---

If your machine is set to `Manual` mode and you want to use the remote retrieval features, wait for about 100 seconds after it starts ringing, and then enter the remote access code within 30 seconds.

---

## Remote Fax commands

Follow the commands below to access features when you are away from the machine. When you call the machine and enter your remote access code (3 digits followed by \*), the system will give two short beeps and you must enter a remote command.

Remote commands		Operation details
95	<b>Change the Fax Forwarding or Fax Storage settings</b>	
	1 OFF	You can choose OFF after you have retrieved or erased all your messages.
	2 Fax Forwarding	One long beep means the change is accepted. If you hear three short beeps, the change was not accepted because something has not been set up (for example, a Fax Forwarding number has not been registered). You can register your Fax Forwarding number by entering 4. (See <i>Changing your Fax Forwarding number</i> on page 63.) Once you have registered the number, Fax Forwarding will work.
	4 Fax Forwarding number	
	6 Fax Storage	
96	<b>Retrieve a fax</b>	
	2 Retrieve all faxes	Enter the number of a remote fax machine to receive stored fax messages. (See <i>Retrieving fax messages</i> on page 63.)
	3 Erase faxes from the memory	If you hear one long beep, fax messages have been erased from the memory.
97	<b>Check the receiving status</b>	
	1 Fax	You can check whether your machine has received any faxes. If yes, you will hear one long beep. If no, you will hear three short beeps.
98	<b>Change the Receive Mode</b>	
	1 External TAD	If you hear one long beep, your change has been accepted.
	2 Fax/Tel	
	3 Fax Only	
90	<b>Exit</b>	Pressing 9 0 allows you to exit remote retrieval. Wait for the long beep, then replace the handset.

## Retrieving fax messages

---

You can call your machine from any touch tone telephone and have your fax messages sent to a machine. Before you use this feature, you have to turn on Fax Storage.

- 1 Dial your fax number.
- 2 When your machine answers, enter your remote access code (3 digits followed by \*) at once. If you hear one long beep, you have messages.
- 3 When you hear two short beeps, press **9 6 2**.
- 4 Wait for the long beep, enter the number (up to 20 digits) of the remote fax machine you want your fax messages sent to using the dial pad, then enter **# #**.



### Note

---

You cannot use \* and # as dial numbers. However, press # if you want to create a pause.

- 5 Hang up after you hear your machine beep. Your machine will call the other fax machine, which will then print your fax messages.

## Changing your Fax Forwarding number

---

You can change the default setting of your fax forwarding number from another touch tone telephone or fax machine.

- 1 Dial your fax number.
- 2 When your machine answers, enter your remote access code (3 digits followed by \*) at once. If you hear one long beep, you have messages.
- 3 When you hear two short beeps, press **9 5 4**.
- 4 Wait for the long beep, enter the new number (up to 20 digits) of the remote fax machine you want your fax messages forwarded to using the dial pad, then enter **# #**.



### Note

---

You cannot use \* and # as dial numbers. However, press # if you want to create a pause.

- 5 Press **9 0** when you have finished.
- 6 Hang up after you hear your machine beep.

## Voice operations

Voice calls can be made either with an extension or external telephone, by dialling manually, or by using Quick Dial numbers.

### Tone or Pulse

---

If you have a Pulse dialling service, but need to send Tone signals (for example, for telephone banking), follow the instructions below:

- 1 Pick up the handset of the external telephone.
- 2 Press **#** on the machine's control panel. Any digits dialled after this will send tone signals.

When you hang up, the machine will return to the Pulse dialling service.

### Fax/Tel mode

---

When the machine is in Fax/Tel mode, it will use the F/T Ring Time (pseudo/double-ringing) to alert you to pick up a voice call.

If you are at an external telephone, lift the handset of the external telephone, and then press **Tel/R** to answer.

If you are at an extension telephone, you'll need to lift the handset during the F/T Ring Time and then press **# 5 1** between the pseudo/double rings. If no one is on the line, or if someone wants to send you a fax, send the call back to the machine by pressing **\* 5 1**.

### Fax/Tel mode in Power Save condition

---

When the machine is in Power Save mode you can receive faxes if the Power Save setting is **Fax Receive:On**. (See *Power Save setting* on page 25.)

Fax/Tel mode does not work in the Power Save condition. The machine will not answer telephone or fax calls and will keep ringing. If you are at an external or extension telephone, lift the handset and talk. If you hear fax tones, hold the handset until Fax Detect activates your machine. If the other party says they want to send you a fax, activate the machine by pressing **\* 5 1**.

## Telephone services

Your machine supports the Caller ID subscriber telephone service that some telephone companies offer.

Features like Voice Mail, Call Waiting, Call Waiting/Caller ID, answering services, alarm systems or other custom features on one telephone line may create problems with the operation of your machine.



### Note

Caller ID is available for U.K. and Ireland only.

## Caller ID (U.K. and Ireland only)

The Caller ID feature lets you use the Caller ID subscriber service offered by many local telephone companies. Call your telephone company for details. This service shows the telephone number, or name if it is available, of your caller as the line rings.

After a few rings, the LCD shows the telephone number of your caller (and name, if available). Once you answer a call, the Caller ID information disappears from the LCD, but the call information stays stored in the Caller ID memory.

- You can see the first 18 characters of the number (or name).
- The ID `Unknown` message means the call originated outside your Caller ID service area.
- The ID `Withheld` message means the caller has intentionally blocked transmission of information.

You can print a list of the Caller ID information received by your machine. (See *How to print a report* on page 83.)



### Note

The Caller ID service varies with different carriers. Call your local telephone company to find out about the kind of service available in your area.

## Setting the Caller ID to On

If you have Caller ID on your line, then this function should be set to `On` to display the caller's telephone number on the LCD as the telephone rings.

- 1 Press **Menu**.
- 2 Press **▲** or **▼** to choose `Fax`. Press **OK**.
- 3 Press **▲** or **▼** to choose `Miscellaneous`. Press **OK**.
- 4 Press **▲** or **▼** to choose `Caller ID`.
- 5 Press **◀** or **▶** to choose `On` (or `Off`). Press **OK**.
- 6 Press **Stop/Exit**.

## Setting the Telephone Line Type

If you are connecting the machine to a line that features PBX or ISDN to send and receive faxes, it is also necessary to change the Telephone Line Type accordingly by completing the following steps.

- 1 Press **Menu**.
- 2 Press **▲** or **▼** to choose *Initial Setup*. Press **OK**.
- 3 Press **▲** or **▼** to choose *Phone Line Set*.
- 4 Press **◀** or **▶** to choose *PBX, ISDN (or Normal)*. Press **OK**.
- 5 Press **Stop/Exit**.

### PBX and TRANSFER

The machine is initially set to *Normal*, which lets the machine connect to a standard PSTN (Public Switched Telephone Network) line. However, many offices use a central telephone system or Private Branch Exchange (PBX). Your machine can be connected to most types of PBX. The machine's recall feature supports timed break recall only (TBR). TBR will work with most PBX systems allowing you to gain access to an outside line, or transfer calls to another extension. The feature works when **Tel/R** is pressed.



### Note

You can program a **Tel/R** key press as part of a number stored in a One Touch dial or Speed Dial location. When programming the One Touch dial or Speed Dial number, press **Tel/R** first (the LCD shows '!'), then enter the telephone number. If you do this, you do not need to press **Tel/R** each time before you dial using a One Touch dial or Speed Dial location. (See *Storing numbers* on page 74.) However, if PBX is not chosen in the Telephone Line Type setting, you cannot use the One Touch dial or Speed Dial number that the **Tel/R** press is programmed into.

## BT Call Sign (U.K. only)

This machine feature lets you use the BT Call Sign subscriber service which allows you to have at least two separate telephone numbers on one telephone line. Each telephone number has its own distinctive ringing pattern, so you know which telephone number is ringing. This is one way you can have a separate telephone number for your machine.

Your machine has a BT Call Sign compatible distinctive ringing function, allowing you to dedicate a second telephone number (on the same telephone line) just for receiving faxes.



### Note

- You can switch BT Call Sign off temporarily, then turn it back on. When you get a new fax number, make sure you reset this function. This machine will automatically answer incoming calls that use your new fax number.
- When you set the BT Call Sign feature to ON, the receive mode is set to *Manual* automatically. *Manual* mode will not respond to incoming telephone calls, since the number you use for telephone calls will use the normal ring pattern.

## To enable the machine to work with BT Call Sign (With your external telephone only)

- 1 Press **Menu**.
- 2 Press **▲** or **▼** to choose **Fax**. Press **OK**.
- 3 Press **▲** or **▼** to choose **Miscellaneous**. Press **OK**.
- 4 Press **▲** or **▼** to choose **BT Call Sign**.
- 5 Press **◀** or **▶** to choose **On (or Off)**. Press **OK**.
- 6 Press **Stop/Exit**.



### Note

If you turn off **BT Call Sign**, the receive mode stays in **Manual**. You will need to set receive mode again. (See *Choose the Receive Mode* on page 49.)

## Connecting an external TAD (telephone answering device)

You may choose to connect an external answering device. However, when you have an **external TAD** on the same telephone line as the machine, the TAD answers all calls and the machine 'listens' for fax calling (CNG) tones. If it hears them, the machine takes over the call and receives the fax. If it does not hear CNG tones, the machine lets the TAD continue playing your outgoing message so your caller can leave you a voice message.

The TAD must answer within four rings (the recommended setting is two rings). The machine cannot hear CNG tones until the TAD has answered the call, and with four rings there are only 8 to 10 seconds of CNG tones left for the fax 'handshake'. Make sure you carefully follow the instructions in this guide for recording your outgoing message. We do not recommend using the toll saver feature on your external answering machine if it exceeds five rings.



### Note

If you do not receive all your faxes, shorten the Ring Delay setting on your external TAD.

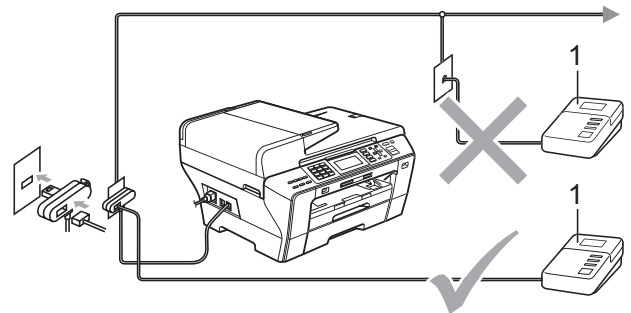

### 1 TAD

When the TAD answers a call, the LCD shows **Telephone**.

### Improper Setup

DO NOT connect a TAD elsewhere on the same telephone line.

## Connections

---

The external TAD must be connected as shown in the previous illustration.

- 1 Set your external TAD to one or two rings. (The machine's Ring Delay setting does not apply.)
- 2 Record the outgoing message on your external TAD.
- 3 Set the TAD to answer calls.
- 4 Set the Receive Mode to *External TAD*. (See *Choose the Receive Mode* on page 49.)

## Recording outgoing message (OGM) on an external TAD

---

Timing is important in recording this message. The message sets up the ways to handle both manual and automatic fax reception.

- 1 Record 5 seconds of silence at the beginning of your message. (This allows your machine time to listen for the fax CNG tones of automatic transmissions before they stop.)
- 2 Limit your speaking to 20 seconds.



### Note

---

We recommend beginning your OGM with an initial 5-second silence because the machine cannot hear fax tones over a resonant or loud voice. You may try omitting this pause, but if your machine has trouble receiving, then you must re-record the OGM to include it.

---

## Multi-line connections (PBX)

---

We suggest you ask the company who installed your PBX to connect your machine. If you have a multi line system we suggest you ask the installer to connect the unit to the last line on the system. This prevents the machine being activated each time the system receives telephone calls. If all incoming calls will be answered by a switchboard operator we recommend that you set the Receive Mode to *Manual*.

We cannot guarantee that your machine will operate properly under all circumstances when connected to a PBX. Any difficulties with sending or receiving faxes should be reported first to the company who handles your PBX.



### Note

---

Make sure the Telephone Line Type is set to PBX. (See *Setting the Telephone Line Type* on page 66.)

---

## External and extension telephones

### Connecting an external or extension telephone

You can connect a separate telephone to your machine as shown in the diagram below.

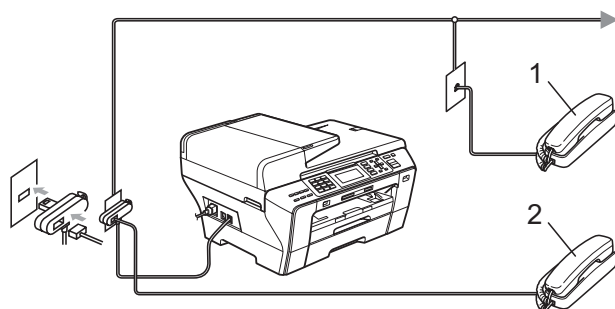

1 Extension telephone

2 External telephone

When you are using an external or extension telephone, the LCD shows *Telephone*.

### Operation from extension telephones

If you answer a fax call on an extension or an external telephone, you can make your machine take the call by using the Remote Activation Code. When you press the Remote Activation Code \* 5 1, the machine starts to receive the fax.

If the machine answers a voice call and pseudo/double-rings for you to take over, use the Remote Deactivation Code # 5 1 to take the call at an extension telephone. (See *F/T Ring Time (Fax/Tel mode only)* on page 51.)

### If you answer a call and no one is on the line:

You should assume that you're receiving a manual fax.

Press \* 5 1 and wait for the chirp or until the LCD shows *Receiving*, and then hang up.



#### Note

You can also use the Fax Detect feature to make your machine automatically take the call. (See *Fax Detect* on page 52.)

### Using extension telephones (For U.K. only)

Your premises may already be wired with parallel extension telephones, or you may plan to add extension telephones to your line, as well as your machine. While the simplest arrangement is a straightforward parallel connection, there are some problems with this arrangement, the most obvious of which is inadvertent interruption of a facsimile transmission caused by someone picking up an extension telephone to make an outgoing call. Also, remote activation code may not operate reliably in such a simple configuration.

This machine may also be set to make a delayed transmission (i.e. a transmission at a pre-set time). This pre-set job may coincide with someone picking up an extension handset.

These problems can easily be eliminated, if you arrange modification of your extension wiring circuit, such that extension devices are connected 'downstream' of your machine in a master/slave configuration (see fig. 2). In this configuration the machine can always detect whether a telephone is in use. Thus it will not attempt to seize the line during that time. This is known as 'telephone off-hook detection.'

The inadvisable configuration is shown in figure 1, and the recommended master/slave configuration is shown in figure 2.

This new connection configuration can be arranged by contacting BT, Kingston upon Hull Telecommunications, your PBX maintainer or a qualified telephone installation company as appropriate. Simply explained, the extension telephone circuit should be terminated on a normal modular plug (BT 431A style), which in turn should be put into the modular socket of the white 'T'-shaped connector provided as part of the line cord assembly.

### Inadvisable connection of extension sockets (Fig. 1.)

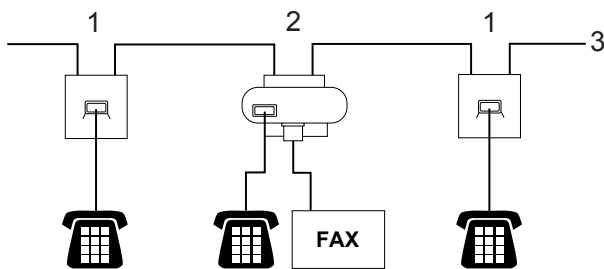

- 1 Extension socket
- 2 Master socket
- 3 Incoming line

### Recommended connection of extension sockets (Fig. 2.)

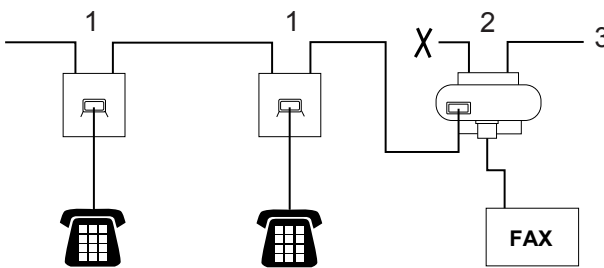

- 1 Extension socket
- 2 Master socket
- 3 Incoming line

The fax machine must be plugged into the master socket.

#### Note

These telephones are now connected as external devices (see *Connecting an external or extension telephone* on page 69), because they are connected to the fax machine via the T-connector.

## Using a cordless external telephone

If your cordless telephone is connected to the telephone line cord (See *External and extension telephones* on page 69) and you typically carry the cordless handset elsewhere, it is easier to answer calls during the Ring Delay.

If you let the machine answer first, you will have to go to the machine so you can press **Tel/R** to send the call to the cordless handset.

## Using remote codes

### Remote Activation code

If you answer a fax call on an extension telephone, you can tell your machine to receive it by dialling the Remote Activation Code \* **5 1**. Wait for the chirping sounds then replace the handset. (See *Fax Detect* on page 52.) Your caller will have to press **Start** to send the fax.

If you answer a fax call at the external telephone, you can make the machine receive the fax by pressing **Mono Start** and choose *Receive*.

### Remote Deactivation code

If you receive a voice call and the machine is in F/T mode, it will start to sound the F/T (double) ring after the initial ring delay. If you pick up the call on an extension telephone you can turn the F/T ring off by pressing **# 5 1** (make sure you press this *between* the rings).

If the machine answers a voice call and pseudo/double-rings for you to take over, you can take the call at the external telephone by pressing **Tel/R**.

## Changing the remote codes

If you want to use Remote Activation, you have to turn on the remote codes. The preset Remote Activation Code is \* 5 1. The preset Remote Deactivation Code is # 5 1. If you want to, you can replace them with your own codes.

- 1 Press **Menu**.
- 2 Press ▲ or ▼ to choose **Fax**.  
Press **OK**.
- 3 Press ▲ or ▼ to choose **Setup Receive**.  
Press **OK**.
- 4 Press ▲ or ▼ to choose **Remote Codes**.
- 5 Press ◀ or ▶ to choose **On (or Off)**.  
Press **OK**.
- 6 Enter the new Remote Activation Code.  
Press **OK**.
- 7 Press ▲ or ▼ to choose **Deact. Code**:  
and enter the new Remote Deactivation Code.  
Press **OK**.
- 8 Press **Stop/Exit**.



### Note

---

- If you are always disconnected when accessing your external TAD remotely, try changing the Remote Activation Code and Remote Deactivation Code to another three-digit code using the numbers **0-9**, \*, #.
  - Remote Codes might not work with some telephone systems.
-

# 8

# Dialling and storing numbers

## How to Dial

### Manual dialling

Press all of the digits of the fax or telephone number.



### One Touch Dialling

Your machine has 3 One Touch keys where you can store 6 fax or telephone numbers for automatic dialling.

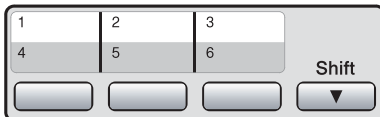



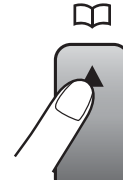

Press the One Touch key that stores the number you want to call. (See *Storing One Touch Dial numbers* on page 74.) To access numbers 4 to 6, hold down **Shift** as you press the One Touch key.

## Speed Dialling

- 1 Press  (Phone Book).



You can also choose Phone Book by pressing  (Fax).

- 2 Press  or  to choose Search. Press **OK**.
- 3 Press the two-digit Speed Dial number. (See *Storing Speed Dial numbers* on page 76.)
- 4 If you have two numbers in the location, press  or  to choose the number you want to call. Press **OK**.





### Note

If the LCD shows *Not Registered* when you enter or search a One Touch or Speed Dial number, a number has not been stored at this location.

## Search

You can search for names you have stored in the One Touch and Speed Dial memory.

- 1 Press  (**Phone Book**).  
You can also choose **Phone Book** by pressing  (**Fax**).
- 2 Press ▲ or ▼ to choose **Search**.  
Press **OK**.
- 3 Press ▲ or ▼ to choose **Alphabetical Order** or **Numerical Order**.  
Press **OK**.



### Note

- Press \* to make the LCD font size larger.
- Press # to make the LCD font size smaller.

- 4 If you chose **Alphabetical Order** in step 3, use the dial pad to enter the first letter of the name, and then press ▲ or ▼ to choose the name and number you want to call.  
Press **OK**.

## Fax Redial

If you are sending a fax manually and the line is busy, press **Redial/Pause**, and then press **Mono Start** or **Colour Start** to try again. If you want to make a second call to a number you recently dialled, you can press **Redial/Pause** and choose one of the last 30 numbers from the **Outgoing Call List**.

**Redial/Pause** only works if you dialled from the control panel. *If you are sending a fax automatically* and the line is busy, the machine will automatically redial up to three times at five minute intervals.

- 1 Press **Redial/Pause**.
- 2 Press ▲ or ▼ to choose the number you want to redial.  
Press **OK**.

- 3 Press ▲ or ▼ to choose **Send a fax**.  
Press **OK**.
- 4 Press **Mono Start** or **Colour Start**.



### Note

In **Real Time Transmission** the automatic redial feature does not work when using the scanner glass.

## Outgoing Call history

The last 30 numbers you sent a fax to will be stored in the **outgoing call history**. You can choose one of these numbers to fax to, add to **One Touch** or **Speed Dial**, or delete from the history.

- 1 Press **Redial/Pause**.  
You can also choose **Outgoing Call** by pressing  (**Fax**).
- 2 Press ▲ or ▼ to choose the number you want.  
Press **OK**.
- 3 Do one of the following:
  - To send a fax, press ▲ or ▼ to choose **Send a fax**.  
Press **OK**.  
  
Press **Mono Start** or **Colour Start**.
  - If you want to store the number, press ▲ or ▼ to choose **Add To Phone Book**.  
Press **OK**.  
  
(See *Storing One Touch numbers from Outgoing Calls* on page 75 or *Storing Speed Dial numbers from Outgoing Calls* on page 77.)
  - Press ▲ or ▼ to choose **Delete**.  
Press **OK**.  
Press 1 to confirm.
- 4 Press **Stop/Exit**.

## Caller ID history

This feature requires the Caller ID subscriber service offered by many local telephone companies. (See *Caller ID (U.K. and Ireland only)* on page 65.)

The number, or name if available, from the last 30 faxes and telephone calls you received will be stored in the Caller ID history. You can view the list or choose one of these numbers to fax to, add to One Touch or Speed Dial, or delete from the history. When the thirty-first call comes in to the machine, it replaces information about the first call.

- 1 Press  (**Fax**).
- 2 Press **▲** or **▼** to choose  
Caller ID hist.  
Press **OK**.
- 3 Press **▲** or **▼** to choose the number you want.  
Press **OK**.
- 4 Do one of the following:
  - To send a fax, press **▲** or **▼** to choose  
Send a fax.  
Press **OK**.  
Press **Mono Start** or **Colour Start**.
  - If you want to store the number, press **▲** or **▼** to choose  
Add To Phone Book.  
Press **OK**.  
(See *Storing Speed Dial numbers from Outgoing Calls* on page 77.)
  - Press **▲** or **▼** to choose **Delete**.  
Press **OK**.  
Press **1** to confirm.
- 5 Press **Stop/Exit**.

### Note

You can print the Caller ID list.  
(See *How to print a report* on page 83.)

## Storing numbers

You can set up your machine to do the following types of easy dialling: One Touch, Speed Dial and Groups for broadcasting faxes. When you dial a Quick Dial number, the LCD shows the name, if you stored it, or the number.



### Note

If you lose electrical power, the Quick Dial numbers that are in the memory will not be lost.

## Storing a pause

Press **Redial/Pause** to put a 3.5-second pause between numbers. If you are dialling overseas, you can press **Redial/Pause** as many times as needed to increase the length of the pause.

## Storing One Touch Dial numbers

Your machine has 3 One Touch keys where you can store 6 fax or telephone numbers for automatic dialling. To access numbers 4 to 6 hold down **Shift** as you press the One Touch key.

- 1 Press the One Touch key where you want to store the number.  
Press **1** to choose **Yes**.



### Note

You can also store one Touch Dial numbers pressing  (**Phone Book**).

Press **▲** or **▼** to choose  
Set One Touch Dial.  
Press **OK**.

Press **▲** or **▼** to choose the location where you want to store the number in.  
Press **OK**.

- 2 Do one of the following:
  - Enter the name (up to 16 characters) using the dial pad.  
Press **OK**.  
(To help you enter letters, see *Entering Text* on page 194.)
  - To store the number without a name, press **OK**.

- 3 Enter the fax or telephone number (up to 20 digits).  
Press **OK**.

**Note**

(MFC-6490CW only)

If you want to store an E-mail address to use with Internet fax or Scan to E-mail server, press **▲** to choose *Dial Type*, and then press **◀** or **▶** to change the option to *E-Address*. Press **▼** to choose *FAX/TEL/MAIL* and then enter the E-mail address. (See *Entering Text* on page 194.)

- 4 Press **▲** or **▼** to choose *Complete*.  
Press **OK**.
- 5 Press **Stop/Exit**.

### Storing One Touch numbers from Outgoing Calls

You can store One Touch numbers from the Outgoing Call history.

- 1 Press **Redial/Pause**.  
You can also choose *Outgoing Call* by pressing  (**Fax**).
- 2 Press **▲** or **▼** to choose the name or number you want to store.  
Press **OK**.
- 3 Press **▲** or **▼** to choose *Add To Phone Book*.  
Press **OK**.

- 4 Press **▲** or **▼** to choose the One Touch Dial number where you want to store the number.  
Press **OK**.

**Note**

One Touch Dial numbers begin with \* (for example, \* **0 2**).

- 5 Do one of the following:
  - Enter the name using the dial pad (up to 16 characters).  
Press **OK**.  
(To help you enter letters, see *Entering Text* on page 194.)
  - To store the number without a name, press **OK**.
- 6 Press **OK** to confirm the fax or telephone number.
- 7 Press **▲** or **▼** to choose *Complete*.  
Press **OK**.
- 8 Press **Stop/Exit**.

### Storing One Touch numbers from the Caller ID history

If you have the Caller ID subscriber service from your telephone company you can also store One Touch numbers from incoming calls in the Caller ID History. (See *Caller ID (U.K. and Ireland only)* on page 65.)

- 1 Press  (**Fax**).
- 2 Press **▲** or **▼** to choose *Caller ID hist.*  
Press **OK**.
- 3 Press **▲** or **▼** to choose the number you want to store.  
Press **OK**.
- 4 Press **▲** or **▼** to choose *Add To Phone Book*.  
Press **OK**.

- 5 Press ▲ or ▼ to choose the 2-digit One Touch location where you want to store the number in.  
Press **OK**.

**Note**

One Touch Dial numbers begin with \* (for example, \* 0 2).

- 6 Do one of the following:
  - Enter the name (up to 16 characters) using the dial pad.  
Press **OK**.  
(To help you enter letters, see *Entering Text* on page 194.)
  - To store the number without a name, press **OK**.
- 7 Press **OK** to confirm the fax or telephone number.
- 8 Press ▲ or ▼ to choose *Complete*.  
Press **OK**.
- 9 Press **Stop/Exit**.

## Storing Speed Dial numbers

You can store up to 80 (MFC-5890CN) or 100 (MFC-6490CW) 2-digit Speed Dial locations with a name, and each name can have two numbers. When you dial you will only have to press a few keys (For example:

(Phone Book), the two-digit number, and **Mono Start** or **Colour Start**).

- 1 Press (Phone Book).
- 2 Press ▲ or ▼ to choose *Set Speed Dial*.  
Press **OK**.
- 3 Press ▲ or ▼ to choose the Speed Dial location where you want to store the number in.  
Press **OK**.

- 4 Do one of the following:
  - Enter the name (up to 16 characters) using the dial pad.  
Press **OK**.

(To help you enter letters, see *Entering Text* on page 194.)

- To store the number without a name, press **OK**.

- 5 Enter the fax or telephone number (up to 20 digits).  
Press **OK**.

**Note**

(MFC-6490CW only)

If you want to store an E-mail address to use with Internet fax or Scan to E-mail server, press ▲ to choose *Dial Type*, and then press ◀ or ▶ to change the option to *E-Address*. Press ▼ to choose *FAX/TEL/MAIL*, and then enter the E-mail address and press **OK**. (See *Entering Text* on page 194.)

- 6 Do one of the following:
  - Enter the second fax or telephone number (up to 20 digits).  
Press **OK**.
  - If you do not want to store a second number, press **OK**.
- 7 Press ▲ or ▼ to choose *Complete*.  
Press **OK**.
- 8 Do one of the following:
  - To store another Speed Dial number, go to step 3.
  - To finish the setting, press **Stop/Exit**.

## Storing Speed Dial numbers from Outgoing Calls

You can also store Speed Dial numbers from the Outgoing Call history.

- 1 Press **Redial/Pause**.  
You can also choose *Outgoing Call* by pressing  (**Fax**).
- 2 Press **▲** or **▼** to choose the name or number you want to store.  
Press **OK**.
- 3 Press **▲** or **▼** to choose *Add To Phone Book*.  
Press **OK**.
- 4 Press **▲** or **▼** to choose the Speed Dial location you want to store the number in.  
Press **OK**.



### Note

Speed Dial numbers begin with # (for example, # 0 2).

- 5 Do one of the following:
  - Enter the name (up to 16 characters) using the dial pad.  
Press **OK**.  
(To help you enter letters, see *Entering Text* on page 194.)
  - To store the number without a name, press **OK**.
- 6 Press **OK** to confirm the fax or telephone number.
- 7 Do one of the following:
  - Enter the second fax or telephone number (up to 20 digits).  
Press **OK**.
  - If you do not want to store a second number, press **OK**.
- 8 Press **▲** or **▼** to choose *Complete*.  
Press **OK**.
- 9 Press **Stop/Exit**.

## Storing Speed Dial numbers from the Caller ID history

If you have the Caller ID subscriber service from your telephone company you can also store Speed Dial numbers from incoming calls in the Caller ID History. (See *Caller ID (U.K. and Ireland only)* on page 65.)

- 1 Press  (**Fax**).
- 2 Press **▲** or **▼** to choose *Caller ID hist.*  
Press **OK**.
- 3 Press **▲** or **▼** to choose the number you want to store.  
Press **OK**.
- 4 Press **▲** or **▼** to choose *Add To Phone Book*.  
Press **OK**.
- 5 Press **▲** or **▼** to choose the 2-digit Speed Dial location you want to store the number in.  
Press **OK**.



### Note

Speed Dial numbers begin with # (for example, # 0 2).

- 6 Do one of the following:
  - Enter the name (up to 16 characters) using the dial pad.  
Press **OK**.  
(To help you enter letters, see *Entering Text* on page 194.)
  - To store the number without a name, press **OK**.
- 7 Press **OK** to confirm the fax or telephone number.
- 8 Do one of the following:
  - Enter the second fax or telephone number (up to 20 digits).  
Press **OK**.
  - If you do not want to store a second number, press **OK**.
- 9 Press **▲** or **▼** to choose *Complete*.  
Press **OK**.
- 10 Press **Stop/Exit**.

## Changing One Touch or Speed Dial names or numbers

You can change a One Touch or Speed Dial name or number that has already been stored.

- 1 Press  (**Phone Book**).
- 2 Press **▲** or **▼** to choose **Set One Touch Dial** or **Set Speed Dial**. Press **OK**.
- 3 Press **▲** or **▼** to choose the 2-digit One Touch or Speed Dial location you want to change. Press **OK**.
- 4 Do one of the following:
  - Press **▲** or **▼** to choose **Change**. Press **OK**.
  - Press **▲** or **▼** to choose **Delete**. Press **OK**. Press **1** to confirm. Go to step 5.



### Note

*How to change the stored name or number:*

If you want to change a character, press **◀** or **▶** to position the cursor under the character you want to change, and then press **Clear/Back**. Re-enter the character.

- 5 Do one of the following:
  - If you want to change the name, press **▲** or **▼** to choose **Name**. Press **OK** and enter the name (up to 16 characters) using the dial pad. Press **OK**.  
(See *Entering Text* on page 194.)
  - If you do not want to change the name, go to step 6.
- 6 Do one of the following:
  - If you want to change the fax or telephone number, press **▲** or **▼** to choose **Fax/Tel1:**. You can also change **Fax/Tel2:** if you are changing Speed Dial. Press **OK** and enter the new fax or telephone number (up to 20 digits). Press **OK**.
  - If you do not want to change the number, go to step 7.
- 7 Press **▲** or **▼** to choose **Complete**. Press **OK**.
- 8 Press **Stop/Exit**.

## Setting up groups for broadcasting

Groups, which can be stored in a One Touch key or a Speed Dial location, allow you to send the same fax message to many fax numbers by pressing only a One Touch key or  (**Phone Book**), the two-digit location and **Mono Start**. First, you'll need to store each fax number in a One Touch key or Speed-Dial location. Then you can include them as numbers in the Group. Each Group uses up a One Touch key or Speed Dial location. You can have up to six Groups, or you can assign up to 165 (MFC-5890CN), 205 (MFC-6490CW) numbers in a large Group.

(See *Storing Speed Dial numbers* on page 76 and *Broadcasting (Monochrome only)* on page 43.)

- 1 Press  (**Phone Book**).
- 2 Press **▲** or **▼** to choose **Setup Groups**. Press **OK**.
- 3 Press **▲** or **▼** to choose **GROUP1**, **GROUP2**, **GROUP3**, **GROUP4**, **GROUP5** or **GROUP6** for the Group name where you will store the fax numbers. Press **OK**.
- 4 Press **▲** or **▼** to choose the 2-digit One Touch or Speed Dial location you want to add to the Group. Press **OK**.



### Note

Speed Dial numbers start with #.  
One Touch numbers start with \*.

- 5 Press **▲** or **▼** to choose **Add Number**. Press **OK**.

- 6 To add numbers to the group, press **▲** or **▼** to choose **Alphabetical Order** or **Numerical Order** and **OK**. Press **▲** or **▼** to select a number and **OK**.



### Note

Speed Dial numbers start with #.  
One Touch numbers start with \*.

- 7 After you have finished adding numbers by repeating steps 5 to 6, press **▲** or **▼** to choose **Complete**. Press **OK**.

- 8 Press **Stop/Exit**.



### Note

You can print a list of all the One Touch and Speed Dial numbers. Group numbers will be marked in the **GROUP** column. (See *Reports* on page 83.)

## Changing a Group name

- 1 Press  (**Phone Book**).
- 2 Press **▲** or **▼** to choose **Setup Groups**. Press **OK**.
- 3 Press **▲** or **▼** to choose the Group name you want to change. Press **OK**.
- 4 Press **▲** or **▼** to choose **Change Group Name**. Press **OK**.



### Note

*How to change the stored name or number:*

If you want to change a character, press **◀** or **▶** to position the cursor under the character you want to change, and then press **Clear/Back**. Re-enter the character.

- 5 Enter the new name (up to 16 characters) using the dial pad. Press **OK**.  
(See *Entering Text* on page 194. For example, type NEW CLIENTS.)
- 6 Press **▲** or **▼** to choose *Complete*. Press **OK**.
- 7 Press **Stop/Exit**.

### Deleting a Group

- 1 Press  (**Phone Book**).
- 2 Press **▲** or **▼** to choose *Setup Groups*. Press **OK**.
- 3 Press **▲** or **▼** to choose the Group you want to delete. Press **OK**.
- 4 Press **▲** or **▼** to choose *Delete*. Press **OK**. Press **1** to confirm.
- 5 Press **Stop/Exit**.

### Deleting a number from a Group

- 1 Press  (**Phone Book**).
- 2 Press **▲** or **▼** to choose *Setup Groups*. Press **OK**.
- 3 Press **▲** or **▼** to choose the Group you want to change. Press **OK**.
- 4 Press **▲** or **▼** to choose the number you want to delete. Press **OK**. Press **1** to confirm.
- 5 Press **▲** or **▼** to choose *Complete*. Press **OK**.
- 6 Press **Stop/Exit**.

## Combining Quick Dial numbers

---

Sometimes you may want to choose from several long distance carriers when you make a call. Rates may vary depending on the time and destination. To take advantage of low rates, you can store the access codes of long-distance carriers and credit card numbers as One Touch and Speed Dial numbers. You can store these long dialling sequences by dividing them and setting them up as separate One Touch and Speed Dial numbers in any combination. You can even include manual dialling using the dial pad. (See *Storing Speed Dial numbers* on page 76.)

For example, you might have stored '555' on Speed Dial: 03 and '7000' on One Touch: 02. You can use them both to dial '555-7000' if you press the following keys:

- 1 Press  (**Phone Book**).
- 2 Press **▲** or **▼** to choose *Search*. Press **OK**.
- 3 Press **▲** or **▼** to choose *Numerical Order*. Press **OK**.
- 4 Press **▲** or **▼** to choose #03. Press **OK**.



### Note

---

Speed Dial numbers start with #.  
One Touch numbers start with \*.

---

- 5 Press **OK** to choose *Send a fax*.
- 6 Press **▲** or **▼** to choose *Phone Book*. Press **OK**.
- 7 Press **▲** or **▼** to choose *Search*. Press **OK**.
- 8 Press **▲** or **▼** to choose *Numerical Order*. Press **OK**.

- 9 Press ▲ or ▼ to choose \*02.  
Press **OK**.
- 10 Press **OK** to choose *Send a fax*.
- 11 Press **Mono Start** or **Colour Start**.  
You will dial '555-7000'.

To temporarily change a number, you can substitute part of the number with manual dialling using the dial pad. For example, to change the number to 555-7001 you could press  (**Phone Book**), choose *Search*, press **03** and then press **7001** using the dial pad.



### Note

---

If you must wait for another dial tone or signal at any point in the dialling sequence, create a pause in the number by pressing **Redial/Pause**. Each key press adds a 3.5-second delay.

---

## Fax reports

You need to set up the Transmission Verification Report and Journal Period using the **Menu** keys.

### Transmission Verification Report

---

You can use the Transmission Verification Report as proof that you sent a fax. This report lists the time and date of transmission and whether the transmission was successful (OK). If you choose **On** or **On+Image**, the report will print for every fax you send.

If you send a lot of faxes to the same place, you may need more than the job numbers to know which faxes you must send again.

Choosing **On+Image**, **Off+Image** or **Off2+Image** (MFC-6490CW) will print a section of the fax's first page on the report to help you remember.

(MFC-5890CN)

When the Verification Report is turned **Off** or **Off+Image**, the Report will only print if there is a transmission error, and the fax could not be sent.

(MFC-6490CW)

When the Transmission Verification Report is turned **Off** or **Off+Image**, the Report will print if there is a transmission error and the fax was not sent. It will also print if there is a transmission error, with images reduced to a smaller size.

When the Transmission Verification Report is set to **Off2** or **Off2+Image**, the Report will only print if there is a transmission error, and the fax could not be sent.



#### Note

---

If you choose **On+Image** or **Off+Image** the image will only appear on the Transmission Verification Report if Real Time Transmission is set to **Off**. (See *Real time transmission* on page 46.)

---

- 1 Press **Menu**.
- 2 Press **▲** or **▼** to choose **Fax**. Press **OK**.
- 3 Press **▲** or **▼** to choose **Report Setting**. Press **OK**.
- 4 Press **▲** or **▼** to choose **XMIT Report**.
- 5 (MFC-5890CN)  
Press **◀** or **▶** to choose **On**, **On+Image**, **Off** or **Off+Image**. Press **OK**.
- (MFC-6490CW)  
Press **◀** or **▶** to choose **On**, **On+Image**, **Off**, **Off+Image**, **Off2** or **Off2+Image**. Press **OK**.
- 6 Press **Stop/Exit**.

## Fax Journal (activity report)

You can set the machine to print a journal at specific intervals (every 50 faxes, 6, 12 or 24 hours, 2 or 7 days). If you set the interval to `Off`, you can still print the report by following the steps in *How to print a report* on page 83. The factory setting is `Every 50 Faxes`.

- 1 Press **Menu**.
- 2 Press **▲** or **▼** to choose `Fax`. Press **OK**.
- 3 Press **▲** or **▼** to choose `Report Setting`. Press **OK**.
- 4 Press **▲** or **▼** to choose `Journal Period`.
- 5 Press **◀** or **▶** to choose an interval. Press **OK**.  
(If you choose 7 days, the LCD will ask you to choose the first day for the 7-day countdown.)
  - `6, 12, 24 hours, 2 or 7 days`  
The machine will print the report at the chosen time and then erase all jobs from its memory. If the machine's memory is filled with the maximum 200 jobs before the time you chose has passed, the machine will print the Journal early and then erase all jobs from the memory. If you want an extra report before it is due to print, you can print it without erasing the jobs from the memory.
  - `Every 50 Faxes`  
The machine will print the Journal when the machine has stored 50 jobs.
- 6 Enter the time to start printing in 24-hour format. Press **OK**.  
(For example: enter 19:45 for 7:45 PM.)
- 7 Press **Stop/Exit**.

## Reports

The following reports are available:

- `XMIT Verify`  
Prints a Transmission Verification Report for your last transmission.
- `Help List`  
A help list showing how to program your machine.
- `Quick Dial`  
Lists names and numbers stored in the One Touch and Speed Dial memory, in alphabetical or numerical order.
- `Fax Journal`  
Lists information about the last incoming and outgoing faxes. (TX: Transmit.) (RX: Receive.)
- `User Settings`  
Lists your settings.
- `Network Config`  
Lists your Network settings.
- `Caller ID hist.`  
Lists the available Caller ID information about the last 30 received faxes and telephone calls.

## How to print a report

- 1 Press **Menu**.
- 2 Press **▲** or **▼** to choose `Print Reports`. Press **OK**.
- 3 Press **▲** or **▼** to choose the report you want. Press **OK**.
- 4 Press **Mono Start**.
- 5 Press **Stop/Exit**.

## Polling overview

Polling lets you set up your machine so other people can receive faxes from you, but they pay for the call. It also lets you call somebody else's fax machine and receive a fax from it, so you pay for the call. The polling feature needs to be set up on both machines for this to work. Not all fax machines support polling.

## Polling receive

Polling receive lets you call another fax machine to receive a fax.

### Setup to receive polling

- 1 Press  (**Fax**).
- 2 Press ▲ or ▼ to choose `Polling RX`.
- 3 Press ◀ or ▶ to choose `Standard`. Press **OK**.
- 4 Enter the fax number you are polling.
- 5 Press **Mono Start** or **Colour Start**.

### Setup to receive polling with secure code

Secure Polling lets you restrict who can get the documents you set up to be polled.

Secure Polling only works with Brother fax machines. If you want to get a fax from a secured Brother machine you have to enter the secure code.

- 1 Press  (**Fax**).
- 2 Press ▲ or ▼ to choose `Polling RX`.

- 3 Press ◀ or ▶ to choose `Secure`. Press **OK**.
- 4 Enter a four-digit secure code. This is the same as the security code of the fax machine you are polling. Press **OK**.
- 5 Enter the fax number you are polling.
- 6 Press **Mono Start** or **Colour Start**.

### Setup to receive delayed polling

Delayed polling lets you set the machine to begin polling receive at a later time. You can only set up *one* delayed polling operation.

- 1 Press  (**Fax**).
- 2 Press ▲ or ▼ to choose `Polling RX`.
- 3 Press ◀ or ▶ to choose `Timer`. Press **OK**.
- 4 Enter the time (in 24-hour format) you want to start polling. For example, enter 21:45 for 9:45 PM. Press **OK**.
- 5 Enter the fax number you are polling.
- 6 Press **Mono Start** or **Colour Start**. The machine makes the polling call at the time you entered.

## Sequential polling (Monochrome only)

Sequential polling lets you request documents from several fax machines in one operation.

- 1 Press  (**Fax**).
- 2 Press ▲ or ▼ to choose `Polling RX`.
- 3 Press ◀ or ▶ to choose `Standard`, `Secure` or `Timer`. Press **OK**.
- 4 Do one of the following:
  - If you chose `Standard`. Press **OK** and go to step 5.
  - If you chose `Secure`, press **OK** and enter a four-digit number. Press **OK**, go to step 5.
  - If you chose `Timer`, press **OK** and enter the time (24-hour format) you want to begin polling. Press **OK**, go to step 5.
- 5 Press ▲ or ▼ to choose `Broadcasting`. Press **OK**.
- 6 Do one of the following:
  - Press ▲ or ▼ to choose `Add Number` and enter a number using a dial pad. Press **OK**.
  - Press ▲ or ▼ to choose `Phone Book` and **OK**. Press ▲ or ▼ to choose `Alphabetical Order` or `Numerical Order` and **OK**. Press ▲ or ▼ to select a number and **OK**.



### Note

One Touch Dial locations begin with \*.  
Speed Dial locations begin with #.

- 8 Press **Mono Start**.  
The machine polls each number or group in turn for a document.

Press **Stop/Exit** while the machine is dialling to cancel the polling process.

To cancel all sequential polling receive jobs, see *Checking and cancelling waiting jobs* on page 47.

## Polled transmit (Monochrome only)

Polled transmit lets you set up your machine to wait with a document so another fax machine can call and retrieve it.

The document will be stored and can be retrieved by any other fax machine until you delete it from the memory. (See *Checking and cancelling waiting jobs* on page 47.)

### Setup for polled transmit

- 1 Press  (**Fax**).
- 2 Load your document.
- 3 Press ▲ or ▼ to choose **Polled TX**.
- 4 Press ◀ or ▶ to choose **Standard**. Press **OK**.
- 5 Press ▲ or ▼ to choose any settings you want to change. Press ◀ or ▶ to choose the settings. After each setting is accepted, you can continue to change more settings.
- 6 Press **Mono Start**.
- 7 If you are using the scanner glass, the LCD will prompt you to choose one of the options.
  - Press **1** to send another page. Go to 8.
  - Press **2** or **Mono Start** to send the document.
- 8 Place the next page on the scanner glass, press **OK**. Repeat 7 and 8 for each additional page. Your machine will automatically send the fax.

## Setup for polled transmit with secure code

Secure Polling lets you restrict who can get the documents you set up to be polled.

Secure Polling only works with Brother fax machines. If another person wants to retrieve a fax from your machine, they will have to enter the secure code.

- 1 Press  (**Fax**).
- 2 Load your document.
- 3 Press ▲ or ▼ to choose **Polled TX**.
- 4 Press ◀ or ▶ to choose **Secure**. Press **OK**.
- 5 Enter a four-digit number. Press **OK**.
- 6 Press ▲ or ▼ to choose any settings you want to change. Press ◀ or ▶ to choose the settings. After each setting is accepted, you can continue to change more settings.
- 7 Press **Mono Start**.



# Copy

---

**Making copies**

**88**

# 11

## Making copies

### How to copy

#### Entering Copy mode

When you want to make a copy, press

 (**Copy**) to illuminate it in blue.

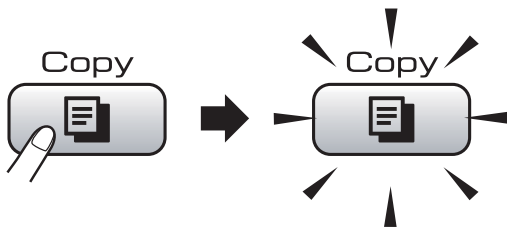

The LCD shows:

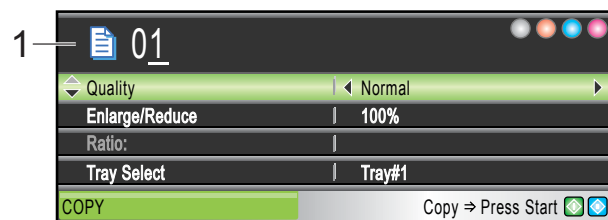

#### 1 No. of Copies

You can enter the number of copies you want by using the dial pad.

Press **▲** or **▼** to scroll through the **Copy** key options.

- Quality (See page 89.)
- Enlarge/Reduce (See page 89.)
- Tray Select (MFC-6490CW) (See page 93.)
- Paper Type (See page 93.)
- Paper Size (See page 93.)
- Brightness (See page 92.)
- Contrast (See page 93.)
- Stack/Sort (See page 92.)
- Page Layout (See page 90.)
- Skew Adjustment (MFC-6490CW) (See page 94.)
- Book Copy (See page 94.)
- Watermark Copy (See page 95.)
- Set New Default (See page 96.)
- Factory Reset (See page 96.)

When the option you want is highlighted, press **OK**.

#### Note

- The default setting is Fax mode. You can change the amount of time that the machine stays in Copy mode after the last copy operation. (See *Mode Timer* on page 26.)

- Book Copy and Watermark Copy features are supported by technology

from Reallusion, Inc. 

#### Making a single copy

- 1 Press  (**Copy**).
- 2 Load your document. (See *Loading documents* on page 22.)
- 3 Press **Mono Start** or **Colour Start**.

#### Making multiple copies

You can make up to 99 copies in one print run.

- 1 Press  (**Copy**).
- 2 Load your document. (See *Loading documents* on page 22.)
- 3 Enter the number of copies you want.
- 4 Press **Mono Start** or **Colour Start**.

#### Note

To sort the copies, press **▲** or **▼** to choose Stack/Sort. (See *Sorting copies using the ADF* on page 92.)

#### Stop copying

To stop copying, press **Stop/Exit**.

## Copy settings

You can change the copy settings temporarily for the next multiple copies.

The machine returns to its default settings after 1 minute, or if the Mode Timer returns the machine to Fax mode. (See *Mode Timer* on page 26.)

If you have finished choosing settings, press **Mono Start** or **Colour Start**.

If you want to choose more settings, press ▲ or ▼.



### Note

You can save some of the settings that you use most often by setting them as default. These settings will stay until you change them again. (See *Setting your changes as a new default* on page 96.)

## Changing copy speed and quality

You can choose from a range of quality. The factory setting is *Normal*.

### ■ Fast

Fast copy speed and lowest amount of ink used. Use to save time printing documents to be proof-read, large documents or many copies.

### ■ Normal

Normal is the recommended mode for ordinary print outs. This produces good copy quality with good copy speed.

### ■ Best

Use best mode to copy precise images such as photographs. This provides the highest resolution and slowest speed.

- 1 Press  (**Copy**).
- 2 Load your document.
- 3 Enter the number of copies you want.

- 4 Press ▲ or ▼ to choose *Quality*.
- 5 Press ◀ or ▶ to choose *Fast*, *Normal* or *Best*.  
Press **OK**.
- 6 If you do not want to change additional settings, press **Mono Start** or **Colour Start**.

## Enlarging or reducing the image copied

You can choose an enlargement or reduction ratio. If you choose *Fit to Page*, your machine will adjust the size automatically to the paper size you set.

(MFC-5890CN only)

If you use this setting, use the scanner glass.

- 1 Press  (**Copy**).
- 2 Load your document.
- 3 Enter the number of copies you want.
- 4 Press ▲ or ▼ to choose *Enlarge/Reduce*.
- 5 Press ◀ or ▶ to choose *100%*, *Enlarge*, *Reduce*, *Fit to Page* or *Custom (25-400%)*.
- 6 Do one of the following:
  - If you chose *Enlarge* or *Reduce*, press **OK** and press ◀ or ▶ to choose the enlargement or reduction ratio you want. Press **OK**.
  - If you chose *Custom (25-400%)*, press **OK** and then enter an enlargement or reduction ratio from 25% to 400%. Press **OK**.
  - If you chose *100%* or *Fit to Page*, go to step 7.

100%
198% 10x15cm→A4
186% 10x15cm→LTR
142% A4→A3, A5→A4
97% LTR→A4
93% A4→LTR
83% LGL→A4
69% A3→A4 (MFC-6490CW only), A4→A5
47% A4→10x15cm
Fit to Page
Custom (25-400%)

- 7** If you do not want to change additional settings, press **Mono Start** or **Colour Start**.



### Note

- Page Layout and Skew Adjustment are not available with Enlarge/Reduce.
- Book Copy, Sort and Watermark Copy are not available with Fit to Page.
- Fit to Page does not work properly if the document on the scanner glass is skewed by more than 3 degrees. Using the document guidelines on the left and top, place your document in the upper left hand corner, with the document face down on the scanner glass.
- Fit to Page is not available for a Legal size document.

## Making N in 1 copies or a poster (Page Layout)

The N in 1 copy feature can help you save paper by letting you copy two or four pages onto one printed page.

(MFC-6490CW) The 1 to 2 feature copies one A3 or Ledger size page onto two A4 or Letter size pages. If you use this setting, use the scanner glass.

You can also produce a poster. When you use the poster feature your machine divides your document into sections, then enlarges the sections so you can assemble them into a poster. If you want to print a poster, use the scanner glass.

### Important

- Make sure paper size is set to Letter, Ledger, A4 or A3.
- You cannot use the Enlarge/Reduce setting with the N in 1 and Poster features.
- If you are producing multiple colour copies, N in 1 copy is not available.
- (P) means Portrait and (L) means Landscape.
- You can only make one poster copy and 1 to 2 copy at a time.



### Note

- Watermark Copy, Book Copy, Sort, Enlarge/Reduce and Skew Adjustment are not available with Page Layout.
- (MFC-5890CN) 4 in 1 and Poster (3 × 3) are not available if you are using A3 or Ledger size paper.

- 1 Press  (**Copy**).
- 2 Load your document.
- 3 Enter the number of copies you want.
- 4 Press ▲ or ▼ to choose Page Layout.
- 5 (MFC-5890CN)  
Press ◀ or ▶ to choose Off(1 in 1),  
2 in 1 (P), 2 in 1 (L),  
4 in 1 (P), 4 in 1 (L),  
Poster(2 x 2) or Poster(3 x 3).  
Press **OK**.  
Go to step 7.

(MFC-6490CW)

Press ◀ or ▶ to choose Off(1 in 1),  
2 in 1 (P), 2 in 1 (L),  
4 in 1 (P), 4 in 1 (L), 1 to 2,  
Poster(2 x 2) or Poster(3 x 3).  
Press **OK**.

If you chose 2 in 1 or  
Poster(2 x 2) with A3 or Ledger, go  
to step 6 to choose the paper size of  
your document.  
If you choose another setting, go to  
step 7.

- 6 (MFC-6490CW)  
Do one of the following:
  - If you chose 2 in 1 (P) or  
2 in 1 (L), press ▲ or ▼ to choose  
Layout Format. Press ◀ or ▶ to  
choose LGRx2 → LGRx1,  
LTRx2 → LGRx1, A3x2 → A3x1 or  
A4x2 → A3x1.
  - If you chose Poster(2 x 2),  
press ▲ or ▼ to choose  
Layout Format. Press ◀ or ▶ to  
choose LGRx1 → LGRx4,  
LTRx1 → LGRx4, A3x1 → A3x4 or  
A4x1 → A3x4.

- 7 If you do not want to change additional  
settings, press **Mono Start** or  
**Colour Start** to scan the page.  
If you placed the document in the ADF  
or are making a poster, the machine  
scans the pages and starts printing.  
**If you are using the scanner glass, go  
to step 8.**
- 8 After the machine scans the page,  
press **1** to scan the next page.
- 9 Place the next page on the scanner  
glass.  
Press **OK**.  
Repeat steps 8 and 9 for each page of  
the layout.
- 10 After all the pages have been scanned,  
press **2** to finish.

**If you are copying from the ADF, insert the  
document face up in the direction shown  
below:**

■ 2 in 1 (P)



■ 2 in 1 (L)



■ 4 in 1 (P)

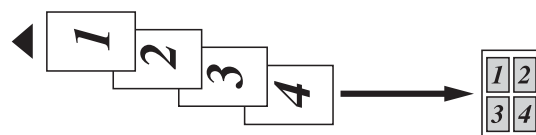

■ 4 in 1 (L)

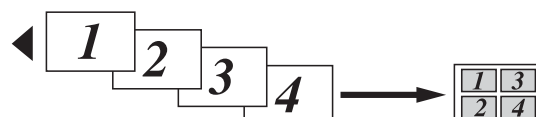

If you are copying from the scanner glass, place the document face down in the direction shown below:

■ **2 in 1 (P)**



■ **2 in 1 (L)**

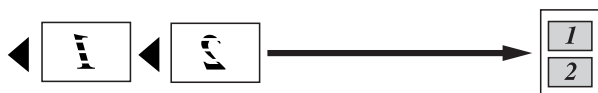

■ **1 to 2 (MFC-6490CW)**



■ **4 in 1 (P)**



■ **4 in 1 (L)**



■ **Poster (2 x 2)**

You can make a poster size copy of a photograph.

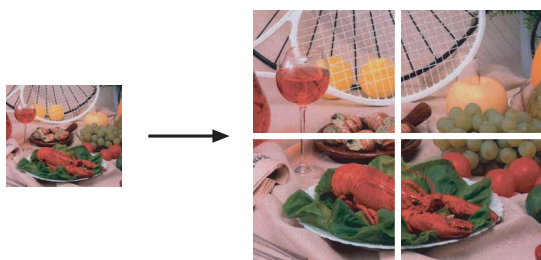

■ **Poster (3 x 3)**

You can make a poster size copy of a photograph.

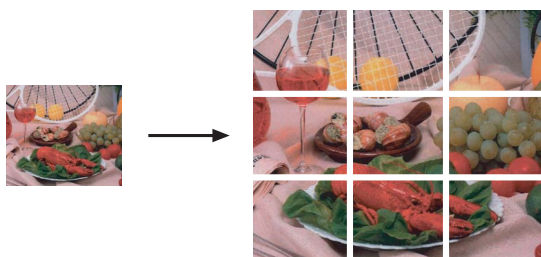

## Sorting copies using the ADF

You can sort multiple copies. Pages will be sorted in the order 321, 321, 321, and so on.

- 1 Press  (**Copy**).
- 2 Load your document.
- 3 Enter the number of copies you want.
- 4 Press ▲ or ▼ to choose *Stack/Sort*.
- 5 Press ◀ or ▶ to choose *Sort*. Press **OK**.
- 6 If you do not want to change additional settings, press **Mono Start** or **Colour Start**.



### Note

*Fit to Page*, *Page Layout* and *Book Copy* are not available with *Sort*.

## Adjusting Brightness and Contrast

### Brightness

You can adjust the copy brightness to make copies darker or lighter.

- 1 Press  (**Copy**).
- 2 Load your document.
- 3 Enter the number of copies you want.
- 4 Press ▲ or ▼ to choose *Brightness*.
- 5 Press ◀ or ▶ to make a darker or lighter copy. Press **OK**.
- 6 If you do not want to change additional settings, press **Mono Start** or **Colour Start**.

## Contrast

You can adjust the copy contrast to help an image look sharper and more vivid.

- 1 Press  (**Copy**).
- 2 Load your document.
- 3 Enter the number of copies you want.
- 4 Press ▲ or ▼ to choose **Contrast**.
- 5 Press ◀ or ▶ to change the contrast. Press **OK**.
- 6 If you do not want to change additional settings, press **Mono Start** or **Colour Start**.

## Paper Options

---

### Paper Type

If you are copying on special paper, set the machine for the type of paper you are using to get the best print quality.

- 1 Press  (**Copy**).
- 2 Load your document.
- 3 Enter the number of copies you want.
- 4 Press ▲ or ▼ to choose **Paper Type**.
- 5 Press ◀ or ▶ to choose **Plain Paper**, **Inkjet Paper**, **Brother BP71**, **Other Glossy** or **Transparency**. Press **OK**.
- 6 If you do not want to change additional settings, press **Mono Start** or **Colour Start**.

### Paper Size

If copying on paper other than A4 size, you will need to change the paper size setting. You can copy only on Ledger, A3, Letter, Legal, A4, A5 or Photo 10 cm × 15 cm paper.

- 1 Press  (**Copy**).
- 2 Load your document.
- 3 Enter the number of copies you want.
- 4 Press ▲ or ▼ to choose **Paper Size**.
- 5 Press ◀ or ▶ to choose **A4**, **A5**, **A3**, **10x15cm**, **Letter**, **Legal** or **Ledger**. Press **OK**.
- 6 If you do not want to change additional settings, press **Mono Start** or **Colour Start**.

### Tray Select (MFC-6490CW only)

You can change the tray that will be used for the next copy. To change the default tray see *Tray use in Copy mode (MFC-6490CW only)* on page 28.

- 1 Make sure you are in Copy mode.
- 2 Load your document.
- 3 Enter the number of copies you want.
- 4 Press ▲ or ▼ to choose **Tray Select**.
- 5 Press ◀ or ▶ to choose **Tray#1** or **Tray#2**. Press **OK**.
- 6 If you do not want to change additional settings, press **Mono Start** or **Colour Start**.

## Skew Adjustment (MFC-6490CW only)

If your copy is scanned skewed, your machine can correct the data automatically. This setting is only available when using the scanner glass and 100% copy.

- 1 Press  (**Copy**).
- 2 Load your document.
- 3 Enter the number of copies you want.
- 4 Press ▲ or ▼ to choose *Skew Adjustment*.
- 5 Press ◀ or ▶ to choose *Auto* (or *Off*). Press **OK**.
- 6 If you do not want to change additional settings, press **Mono Start** or **Colour Start**.



### Note

- *Page Layout*, *Enlarge/Reduce*, *Book Copy* and *Watermark Copy* are not available with *Skew Adjustment*.
- You cannot use this setting with *Ledger*, *A3* or paper smaller than 64 mm × 91 mm.
- This setting is only available for paper that is rectangular or square.
- *Skew Adjustment* is only available if the document is skewed by less than 3 degrees.
- *Skew Adjustment* may not work correctly if your document is too thick.

## Book Copy

Book copy corrects dark borders and skew. Your machine can correct the data automatically or you can make specific corrections.

If you use this setting, use the scanner glass.

- 1 Press  (**Copy**).
- 2 Load your document.
- 3 Enter the number of copies you want.
- 4 Press ▲ or ▼ to choose *Book Copy*.
- 5 Do one of the following:
  - If you want to correct the data yourself, press ◀ or ▶ to choose *On (Preview)*.  
Press **Mono Start** or **Colour Start** and go to step 6.
  - If you want the machine to correct the data automatically, press ◀ or ▶ to choose *On* and go to step 7.
- 6 Adjust the skewed data by using # or ✖. Remove the shadows by using ▲ or ▼.
- 7 If you have finished making corrections, press **Mono Start** or **Colour Start**.



### Note

*Book Copy* is not available with *Page Layout*, *Sort*, *Fit to Page*, *Skew Adjustment* or *Watermark Copy*.

## Watermark Copy

You can place a logo or text into your document as a Watermark. You can select one of the template watermarks, data from your media cards or USB Flash memory drive, or scanned data.



### Note

Watermark Copy is not available with Fit to Page, Page Layout, Skew Adjustment and Book Copy.

### Using a template

- 1 Press  (**Copy**).
- 2 Load your document.
- 3 Enter the number of copies you want.
- 4 Press ▲ or ▼ to choose Watermark Copy. Press **OK**.
- 5 Press ◀ or ▶ to choose On.
- 6 Press ▲ or ▼ to choose Current Setting. Press **OK**.
- 7 Press ▲ or ▼ to choose Template. Press **OK**.
- 8 If you want to change any of the displayed settings, press ▲ or ▼ to choose the setting, and then press ◀ or ▶ to choose the option you want.
- 9 When you are finished changing settings, press ▲ or ▼ to choose Apply. Press **OK**.
- 10 Press **Mono Start** or **Colour Start**.

### Using data from a media card or USB Flash memory drive data

- 1 Press  (**Copy**).
- 2 Load your document.
- 3 Enter the number of copies you want.
- 4 Press ▲ or ▼ to choose Watermark Copy. Press **OK**.
- 5 Press ◀ or ▶ to choose On.
- 6 Press ▲ or ▼ to choose Current Setting. Press **OK**.
- 7 Insert a media card or USB Flash memory drive. Press ▲ or ▼ to choose Media. Press **OK**.
- 8 Press ◀ or ▶ to choose the data you want to use for the watermark. Press **OK**.
- 9 If you want to change any of the displayed settings, press ▲ or ▼ to choose the setting, and then press ◀ or ▶ to choose the option you want.
- 10 When you are finished changing settings, press ▲ or ▼ to choose Apply. Press **OK**.
- 11 Press **Mono Start** or **Colour Start**.

### CAUTION

DO NOT take out the memory card or USB Flash memory drive while **Photo Capture** is blinking to avoid damaging the card, USB Flash memory drive or data stored on the card.

## Using a scanned paper document as your watermark

- 1 Press  (**Copy**).
- 2 Enter the number of copies you want.
- 3 Press ▲ or ▼ to choose `Watermark Copy`. Press **OK**.
- 4 Press ◀ or ▶ to choose `On`.
- 5 Press ▲ or ▼ to choose `Current Setting`. Press **OK**.
- 6 Press ▲ or ▼ to choose `Scan`. Press **OK**, and place the page that you want to use as a watermark on the scanner glass.
- 7 Press **Mono Start** or **Colour Start**.
- 8 Take out the watermark document you scanned and load the document you want to copy.
- 9 Press ◀ or ▶ to change the `Transparency` of the watermark. Press **OK**.
- 10 Press **Mono Start** or **Colour Start**.



### Note

You cannot enlarge or reduce the scanned watermark.

## Setting your changes as a new default

You can save the copy settings for `Quality`, `Enlarge/Reduce`, `Tray Select` (MFC-6490CW only), `Brightness`, `Contrast`, `Page Layout` or `Skew Adjustment` (MFC-6490CW only) that you use most often by setting them as the default settings. These settings will stay until you change them again.

- 1 Press  (**Copy**).
- 2 Press ▲ or ▼ to choose your new setting. Press **OK**. Repeat this step for each setting you want to change.
- 3 After changing the last setting, press ▲ or ▼ to choose `Set New Default`. Press **OK**.
- 4 Press **1** to choose `Yes`.
- 5 Press **Stop/Exit**.

## Restoring all settings to the factory settings

You can restore all the settings you have changed back to the factory settings. These settings will stay until you change them again.

- 1 Press  (**Copy**).
- 2 Press ▲ or ▼ to choose `Factory Reset`. Press **OK**.
- 3 Press **1** to choose `Yes`.
- 4 Press **Stop/Exit**.

## 'Out of Memory' message

If the `Out of Memory` message appears while scanning documents, press **Stop/Exit** to cancel or **Mono Start** or **Colour Start** to copy the scanned pages.

You will need to clear some jobs from the memory before you can continue.

To free up extra memory, do the following:

- Turn off Memory Receive. (See *Memory Receive (Monochrome only)* on page 54.)
- Print the faxes that are in the memory. (See *Printing a fax from the memory* on page 54.)

When you get an `Out of Memory` message, you may be able to make copies if you first print incoming faxes in the memory to restore the memory to 100%.





# Direct Photo Printing

---

<b>Printing photos from a memory card or USB Flash memory drive</b>	<b>100</b>
<b>Printing photos from a camera</b>	<b>118</b>

# Printing photos from a memory card or USB Flash memory drive

## PhotoCapture Center™ Operations

### Printing from a memory card or USB Flash memory drive without a PC

Even if your machine is not connected to your computer, you can print photos directly from digital camera media or a USB Flash memory drive. (See *Print Images* on page 103.)

### Scanning to a memory card or USB Flash memory drive without a PC

You can scan documents and save them directly to a memory card or USB Flash memory drive. (See *Scan to a memory card or USB Flash memory drive* on page 114.)

### Using PhotoCapture Center™ from your computer

You can access a memory card or USB Flash memory drive that is inserted in front of the machine from your PC.

(See *PhotoCapture Center™ for Windows®* or *Remote Setup & PhotoCapture Center™ for Macintosh®* in the Software User's Guide on the CD-ROM.)

## Using a memory card or USB Flash memory drive

Your Brother machine has media drives (slots) for use with the following popular digital camera media: CompactFlash®, Memory Stick®, Memory Stick Pro™, SD, SDHC, xD-Picture Card™ and USB Flash memory drives.



CompactFlash®



Memory Stick®  
Memory Stick Pro™



SD, SDHC



xD-Picture Card™

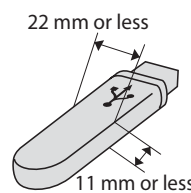

USB Flash memory drive

- miniSD™ can be used with a miniSD™ adapter.
- microSD can be used with a microSD adapter.
- Memory Stick Duo™ can be used with a Memory Stick Duo™ adapter.
- Memory Stick Pro Duo™ can be used with a Memory Stick Pro Duo™ adapter.
- Memory Stick Micro(M2) can be used with a Memory Stick Micro(M2) adapter.
- Adapters are not included with the machine. Contact a third party supplier for adapters.

The PhotoCapture Center™ feature lets you print digital photos from your digital camera at high resolution to get photo quality printing.

## Memory cards or a USB Flash memory drive folder structure

Your machine is designed to be compatible with modern digital camera image files, memory cards and USB Flash memory drive; however, please read the points below to avoid errors:

- The image file extension must be .JPG (Other image file extensions like .JPEG, .TIF, .GIF and so on will not be recognized).
- PhotoCapture Center™ printing must be performed separately from PhotoCapture Center™ operations using the PC. (Simultaneous operation is not available.)
- IBM Microdrive™ is not compatible with the machine.
- The machine can read up to 999 files on a memory card or USB Flash memory drive.
- CompactFlash® Type II is not supported.
- This product supports xD-Picture Card™ Type M / Type M+ / Type H (Large Capacity).
- The DPOF file on the memory cards must be in a valid DPOF format. (See *DPOF printing* on page 109.)

Please be aware of the following:

- When printing **Print Index** or **Print Images**, the PhotoCapture Center™ will print all the valid images, even if one or more images have been corrupted. Corrupted images will not be printed.

### ■ (memory card users)

Your machine is designed to read memory cards that have been formatted by a digital camera.

When a digital camera formats a memory card it creates a special folder into which it copies image data. If you need to modify the image data stored on a memory card with your PC, we recommend that you do not modify the folder structure created by the digital camera. When saving new or modified image files to the memory card we also recommend you use the same folder your digital camera uses. If the data is not saved to the same folder, the machine may not be able to read the file or print the image.

### ■ (USB Flash memory drive users)

This machine supports USB Flash memory drives that have been formatted by Windows®.

## Getting started

Firmly put a memory card or USB Flash memory drive into the correct slot.

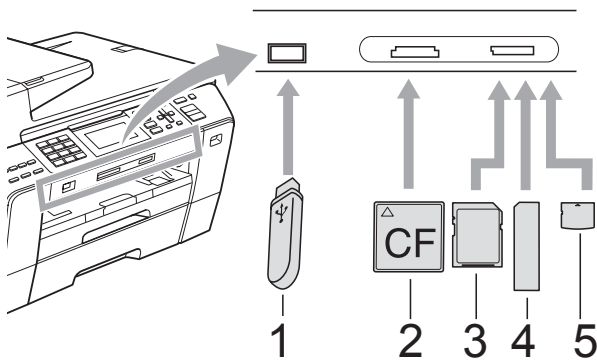

- 1 USB Flash memory drive
- 2 CompactFlash®
- 3 SD, SDHC
- 4 Memory Stick®, Memory Stick Pro™
- 5 xD-Picture Card™

### ! CAUTION

The USB direct interface supports only a USB Flash memory drive, a PictBridge compatible camera, or a digital camera that uses the USB mass storage standard. Any other USB devices are not supported.

**Photo Capture** key indications:

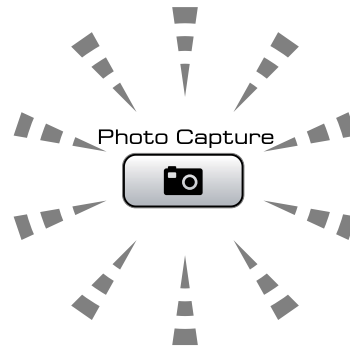

- **Photo Capture** light is on, the memory card or USB Flash memory drive is correctly inserted.
- **Photo Capture** light is off, the memory card or USB Flash memory drive is not correctly inserted.
- **Photo Capture** light is blinking, memory card or USB Flash memory drive is being read or written to.

### ! CAUTION

DO NOT unplug the power cord or remove the media from the media drive (slot) or USB direct interface while the machine is reading or writing to the media (the **Photo Capture** key is blinking). **You will lose your data or damage the card.**

The machine can only read one device at a time.

## Entering PhotoCapture mode

After you insert the memory card or USB Flash memory drive, press the

 (**Photo Capture**) key to illuminate it in blue and display the PhotoCapture options on the LCD.

The LCD shows:

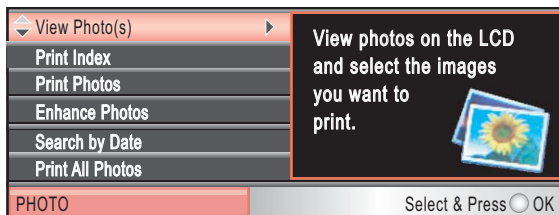

Press **▲** or **▼** to scroll through the PhotoCapture key options.

- View Photo(s) (See page 103.)
- Print Index (See page 104.)
- Print Photos (See page 105.)
- Enhance Photos (See page 105.)
- Search by Date (See page 108.)
- Print All Photos (See page 108.)
- Slide show (See page 108.)
- Trimming (See page 109.)



### Note

If your digital camera supports DPOF printing, see *DPOF printing* on page 109.

When the option you want is highlighted, press **OK**.

## Print Images

### View Photo(s)

You can preview your photos on the LCD before you print them. If your photos are large files there may be a delay before each photo is displayed on the LCD.

- 1 Make sure you have put a memory card or USB Flash memory drive in the correct slot.  
Press  (**Photo Capture**).
- 2 Press **▲** or **▼** to choose View Photo(s).  
Press **OK**.
- 3 Press **◀** or **▶** to choose your photo.



### Note

Instead of scrolling through your photos, you can use the dial pad to enter the number of the image from the index page. (See *Print Index (Thumbnails)* on page 104.)

- 4 Press **▲** or **▼** to increase or decrease the number of copies.
- 5 Repeat step 3 and step 4 until you have chosen all the photos.



### Note

Press **Clear/Back** to go back to the previous level.

- 6 After you have chosen all the photos, do one of the following:
  - Press **OK** and change the print settings. (See page 110.)
  - If you do not want to change any settings, press **Colour Start** to print.

## Print Index (Thumbnails)

The PhotoCapture Center™ assigns numbers for images (such as No.1, No.2, No.3, and so on).



→ NO.1  
DEI.JPG      01.01.2009  
100KB

The PhotoCapture Center™ uses these numbers to identify each picture. You can print a thumbnail page to show all the pictures on the memory card or USB Flash memory drive.



### Note

Only file names that are 8 characters or less will be printed correctly on the index sheet.

- 1 Make sure you have put the memory card or USB Flash memory drive in the correct slot.  
Press  (**Photo Capture**).
- 2 Press ▲ or ▼ to choose **Print Index**. Press **OK**.
- 3 Press ▲ or ▼ to choose **Layout Format**. Press ◀ or ▶ to choose **6 Images/Line** or **5 Images/Line**. Press **OK**.

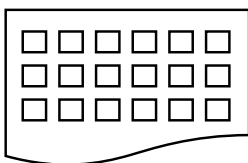

6 Images/Line



5 Images/Line

Print time for 5 Images/Line will be slower than 6 Images/Line, but the quality is better.

- 4 Do one of the following:
  - Press ▲ or ▼ to choose **Paper Type**, and press ◀ or ▶ to choose the type of paper you are using, **Plain Paper**, **Inkjet Paper**, **Brother BP71** or **Other Glossy**.  
Press **OK**.
  - Press ▲ or ▼ to choose **Paper Size** and press ◀ or ▶ to choose the paper size you are using, **A4** or **Letter**.  
Press **OK**.
  - If you do not want to change the paper settings, go to 5.
- 5 Press **Colour Start** to print.

## Printing Photos

Before you can print an individual image, you have to know the image number.

- 1 Make sure you have put a memory card or USB Flash memory drive in the correct slot.  
Press  (**Photo Capture**).
- 2 Print the Index. (See *Print Index (Thumbnails)* on page 104.)
- 3 Press **▲** or **▼** to choose `Print Photos`. Press **OK**.
- 4 Enter the image number that you want to print from the thumbnails printed on the Index page.  
Press **OK**.
- 5 Repeat step 4 until you have entered the image numbers that you want to print.

### Note

- You can enter the numbers at one time by using the \* key for a comma or the # key for a hyphen. For example, Enter **1, \*, 3, \*, 6** to print images No.1, No.3 and No.6. Enter **1, #, 5** to print images No.1 to No.5.
- You can enter up to 12 characters (including commas) for the image numbers you want to print.

- 6 After you have chosen the image numbers, press **OK** again.
- 7 Enter the number of copies you want using the dial pad.
- 8 Do one of the following:
  - Change the print settings. (See page 110.)
  - If you do not want to change any settings, press **Colour Start** to print.

## Enhance Photos

You can edit and add effects to your photos and view them on the LCD before printing.

### Note

- After adding each effect, you can enlarge the view of the image by pressing \*. To go back to the original size, press \* again.
- The Enhance Photos feature is supported by technology from Reallusion, Inc.



## Auto Correct

Auto Correct is available for most photos. The machine decides the suitable effect for your photo.

- 1 Make sure you have put a memory card or USB Flash memory drive in the correct slot.  
Press  (**Photo Capture**).
- 2 Press **▲** or **▼** to choose `Enhance Photos`.  
Press **OK**.
- 3 Press **◀** or **▶** to choose your photo.  
Press **OK**.
- 4 Press **▲** or **▼** to choose `Auto Correct`.  
Press **OK**.
- 5 Press **OK** and **▲** or **▼** to increase or decrease the number of copies.
- 6 Do one of the following.
  - Press **OK** and change the print settings. (See page 110.)
  - If you do not want to change any settings, press **Colour Start** to print.

### Note

If `Remove Red-Eye` appears on the LCD, press # to attempt to remove red-eye from your photo.

## Enhance Skin-Tone

Enhance Skin-Tone is best used for adjusting portrait photographs. It detects human skin colour in your photos and adjusts the image.

- 1 Make sure you have put a memory card or USB Flash memory drive in the correct slot.  
Press  (**Photo Capture**).
- 2 Press ▲ or ▼ to choose *Enhance Photos*.  
Press **OK**.
- 3 Press ◀ or ▶ to choose your photo.  
Press **OK**.
- 4 Press ▲ or ▼ to choose *Enhance Skin-Tone*.  
Press **OK**.
- 5 Do one of the following:
  - Press **OK** if you do not want to change any settings.
  - Press ▲ or ▼ to adjust the effect level manually.  
Press **OK** when you have finished.
- 6 Press ▲ or ▼ to increase or decrease the number of copies.
- 7 Do one of the following.
  - Press **OK** and change the print settings. (See page 110.)
  - If you do not want to change any settings, press **Colour Start** to print.

## Enhance Scenery

Enhance Scenery is best used for adjusting landscape photographs. It highlights green and blue areas in your photo, so that the landscape looks more sharp and vivid.

- 1 Make sure you have put the memory card or USB Flash memory drive in the correct slot.  
Press  (**Photo Capture**).
- 2 Press ▲ or ▼ to choose *Enhance Photos*.  
Press **OK**.
- 3 Press ◀ or ▶ to choose your photo.  
Press **OK**.
- 4 Press ▲ or ▼ to choose *Enhance Scenery*.  
Press **OK**.
- 5 Do one of the following:
  - Press **OK** if you do not want to change any settings.
  - Press ▲ or ▼ to adjust the effect level manually.  
Press **OK** when you have finished.
- 6 Press ▲ or ▼ to increase or decrease the number of copies.
- 7 Do one of the following.
  - Press **OK** and change the print settings. (See page 110.)
  - If you do not want to change any settings, press **Colour Start** to print.

## Remove Red-Eye

The machine detects eyes in your photos and will attempt to remove red-eye from your photo.



### Note

There are some cases when red-eye may not be removed.

- When the face is too small in the image.
- When the face is turning too far up, down, left or right.

- 1 Make sure you have put a memory card or USB Flash memory drive in the correct slot.  
Press  (**Photo Capture**).
- 2 Press ▲ or ▼ to choose *Enhance Photos*.  
Press **OK**.
- 3 Press ◀ or ▶ to choose your photo.  
Press **OK**.
- 4 Press ▲ or ▼ to choose *Remove Red-Eye*.  
Press **OK**.
  - When *Remove Red-Eye* is successful, the photo with the effect is shown. The adjusted part is shown in a red frame.
  - When *Remove Red-Eye* is unsuccessful, *Unable to Detect* is shown.  
Press **OK** to go back to the previous level.



### Note

Press # to try *Remove Red-Eye* once again.

- 5 Press **OK** and ▲ or ▼ to increase or decrease the number of copies.
- 6 Do one of the following.
  - Press **OK** and change the print settings. (See page 110.)
  - If you do not want to change any settings, press **Colour Start** to print.

## Monochrome

You can convert your photo to monochrome.

- 1 Make sure you have put a memory card or USB Flash memory drive in the correct slot.  
Press  (**Photo Capture**).
- 2 Press ▲ or ▼ to choose *Enhance Photos*.  
Press **OK**.
- 3 Press ◀ or ▶ to choose your photo.  
Press **OK**.
- 4 Press ▲ or ▼ to choose *Monochrome*.  
Press **OK**.
- 5 Press **OK** and ▲ or ▼ to increase or decrease the number of copies.
- 6 Do one of the following.
  - Press **OK** and change the print settings. (See page 110.)
  - If you do not want to change any settings, press **Colour Start** to print.

## Sepia

You can convert the colour of your photo to sepia.

- 1 Make sure you have put a memory card or USB Flash memory drive in the correct slot.  
Press  (**Photo Capture**).
- 2 Press ▲ or ▼ to choose *Enhance Photos*.  
Press **OK**.
- 3 Press ◀ or ▶ to choose your photo.  
Press **OK**.
- 4 Press ▲ or ▼ to choose *Sepia*.  
Press **OK**.
- 5 Press **OK** and ▲ or ▼ to increase or decrease the number of copies.
- 6 Do one of the following.
  - Press **OK** and change the print settings. (See page 110.)
  - If you do not want to change any settings, press **Colour Start** to print.

## Search by Date

You can find your photos based on date.

- 1 Make sure you have put a memory card or USB Flash memory drive in the correct slot.  
Press  (**Photo Capture**).
- 2 Press ▲ or ▼ to choose `Search by Date`.  
Press **OK**.
- 3 Press ▲ or ▼ to choose the date that you want to search from.  
Press **OK**.
- 4 Press ◀ or ▶ to choose your photo.



### Note

You can view photos with other dates by pressing ◀ or ▶ continuously. Press ◀ to view an older photo and ▶ to view a more recent photo.

- 5 Press ▲ or ▼ to increase or decrease the number of copies.
- 6 Repeat step 4 and step 5 until you have chosen all your photos.
- 7 After you have chosen all your photos, do one of the following:
  - Press **OK** and change the print settings. (See page 110.)
  - If you do not want to change any settings, press **Colour Start** to print.

## Print All Photos

You can print all the photos on your memory card or USB Flash memory drive.

- 1 Make sure you have put a memory card or USB Flash memory drive in the correct slot.  
Press  (**Photo Capture**).
- 2 Press ▲ or ▼ to choose `Print All Photos`.  
Press **OK**.

- 3 Enter the number of copies you want using the dial pad.
- 4 Do one of the following:
  - Change the print settings. (See page 110.)
  - If you do not want to change any settings, press **Colour Start** to print.

## Slide show

You can view all your photos on the LCD using Slide show. You can also choose a photo during the operation.

- 1 Make sure you have put a memory card or USB Flash memory drive in the correct slot.  
Press  (**Photo Capture**).
- 2 Press ▲ or ▼ to choose `Slide show`.  
Press **OK**.
- 3 Press **Stop/Exit** to finish Slide show.

### Printing a photo during a Slide show

- 1 Make sure you have put a memory card or USB Flash memory drive in the correct slot.  
Press  (**Photo Capture**).
- 2 Press ▲ or ▼ to choose `Slide show`.  
Press **OK**.
- 3 Press **OK** to stop at one image while Slide show is operating.
- 4 Press ▲ or ▼ to increase or decrease the number of copies.
- 5 Do one of the following:
  - Press **OK** and change the print settings. (See page 110.)
  - If you do not want to change any settings, press **Colour Start** to print.

## Trimming

You can trim your photo and print a part of the image.



### Note

If your photo is very small or has irregular proportions you may not be able to trim the photo. The LCD will display

Image Too Small. or  
Image Too Long.

- 1 Make sure you have put a memory card or USB Flash memory drive in the correct slot.  
Press  (**Photo Capture**).
- 2 Press **▲** or **▼** to choose `Trimming`. Press **OK**.
- 3 Press **◀** or **▶** to choose your photo. Press **OK**.
- 4 Adjust the red frame around your photo. The part inside of the red frame will be printed.
  - Press **\*** or **#** to enlarge or reduce the frame size.
  - Press each arrow key to move the position of the frame.
  - Press **0** to rotate the frame.
  - Press **OK** when you have finished adjusting the frame setting.
- 5 Press **▲** or **▼** to increase or decrease the number of copies.
- 6 Do one of the following:
  - Press **OK** and change the print settings. (See page 110.)
  - If you do not want to change any settings, press **Colour Start** to print.

## DPOF printing

DPOF stands for Digital Print Order Format.

Major digital camera manufacturers (Canon Inc., Eastman Kodak Company, Fuji Photo Film Co. Ltd., Matsushita Electric Industrial Co. Ltd. and Sony Corporation) created this standard to make it easier to print images from a digital camera.

If your digital camera supports DPOF printing, you will be able to choose on the digital camera display the images and number of copies you want to print.

When a memory card containing DPOF information is put into your machine, you can print the chosen image easily.

- 1 Make sure you have put a memory card in the correct slot.  
Press  (**Photo Capture**). The machine will ask you if you want to use DPOF setting.
- 2 Press **1** to choose `Yes`.
- 3 Do one of the following:
  - Change the print settings. (See page 110.)
  - If you do not want to change any settings, press **Colour Start** to print.



### Note

An Invalid DPOF File error can occur if the print order that was created on the camera has been corrupted. Delete and recreate the print order using your camera to correct this problem. For instructions on how to delete or recreate the print order, refer to your camera manufacturer's support website or accompanying documentation.

# PhotoCapture Center™ print settings

You can change the print settings temporarily.

The machine returns to its default settings after 3 minutes, or if the Mode Timer returns the machine to Fax mode. (See *Mode Timer* on page 26.)



## Note

You can save the print settings you use most often by setting them as the default. (See *Setting your changes as a new default* on page 114.)



## 1 No. of prints

(For View Photo(s), Search by Date, Slide Show)

You can see the total number of photos that will be printed.

(For Print All Photos, Print Photos, Enhance Photos, Trimming)

You can see the number of copies of each photo that will be printed.

(For DPOF printing) This does not appear.

Menu Selections	Options 1	Options 2	Page
Print Quality (Not available for DPOF printing)	Normal/Photo	—	111
Paper Type	Plain Paper/Inkjet Paper/ Brother BP71/Other Glossy	—	111
Paper Size	10x15cm/13x18cm/ A4/A3/Letter/Ledger	(When A4 or Letter is chosen) 8 x 10cm/ 9 x 13cm/ 10 x 15cm/13 x 18cm/ 15 x 20cm/Max. Size	111
Brightness (Not available when Enhance Photos is chosen)	◀0 Dark ————— Light▶	—	112
Contrast (Not available when Enhance Photos is chosen)	◀0 ————— ▶+	—	112



## Adjusting Brightness, Contrast and Colour

---

### Brightness

- 1 Press ▲ or ▼ to choose `Brightness`.
- 2 Press ◀ or ▶ to make a darker or lighter print.  
Press **OK**.
- 3 If you do not want to change additional settings, press **Colour Start** to print.

### Contrast

You can choose the contrast setting. More contrast will make an image look sharper and more vivid.

- 1 Press ▲ or ▼ to choose `Contrast`.
- 2 Press ◀ or ▶ to change the contrast.  
Press **OK**.
- 3 If you do not want to change additional settings, press **Colour Start** to print.

### Colour Enhancement

You can turn on the colour enhancement feature to print more vivid images. Printing time will be slower.

- 1 Press ▲ or ▼ to choose `Color Enhance`.  
Press **OK**.
- 2 Do one of the following:
  - If you want to customize the `White Balance`, `Sharpness` or `Colour Density`, press ◀ or ▶ to choose `On`, and then go to step 3.
  - If you do not want to customize, press ◀ or ▶ to choose `Off`.  
Press **OK** and then go to step 6.

- 3 Press ▲ or ▼ to choose `White Balance`, `Sharpness` or `Color Density`.
- 4 Press ◀ or ▶ to adjust the degree of the setting.  
Press **OK**.
- 5 Do one of the following:
  - If you want to customize another colour enhancement, press ▲ or ▼ to choose another option.
  - If you want to change other settings, press ▲ or ▼ to choose `Exit`, and then press **OK**.
- 6 If you do not want to change additional settings, press **Colour Start** to print.



### Note

---

- **White Balance**

This setting adjusts the hue of the white areas of an image. Lighting, camera settings and other influences will affect the appearance of white. The white areas of a picture may be slightly pink, yellow or some other colour. By using this setting, you can correct that effect and bring the white areas back to pure white.

- **Sharpness**

This setting enhances the detail of an image, similar to adjusting the fine focus on a camera. If the image is not in true focus and you cannot see the fine details of the picture, then adjust the sharpness.

- **Colour Density**

This setting adjusts the total amount of colour in the image. You can increase or decrease the amount of colour in an image to improve a washed out or weak picture.

---

## Cropping

If your photo is too long or wide to fit the available space on your chosen layout, part of the image will automatically be cropped.

The factory setting is **On**. If you want to print the whole image, turn this setting to **Off**. If you are also using the **Borderless** setting, turn **Borderless** to **Off**. (See *Borderless printing* on page 113.)

- 1 Press ▲ or ▼ to choose **Cropping**.
- 2 Press ◀ or ▶ to choose **Off** (or **On**). Press **OK**.
- 3 If you do not want to change additional settings, press **Colour Start** to print.

### Cropping: On

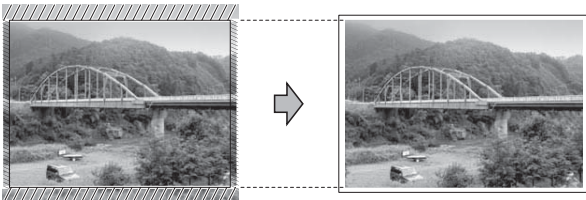

### Cropping: Off

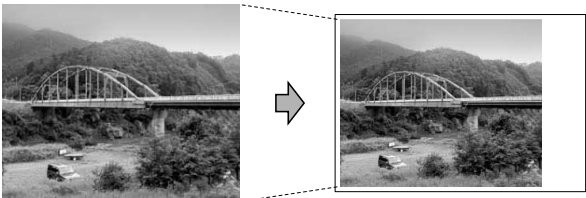

## Borderless printing

This feature expands the printable area to the edges of the paper. Printing time will be slightly slower.

- 1 Press ▲ or ▼ to choose **Borderless**.
- 2 Press ◀ or ▶ to choose **Off** (or **On**). Press **OK**.
- 3 If you do not want to change additional settings, press **Colour Start** to print.

## Date Print

You can print the date if it is already in the data on your photo. The date will be printed on the lower right corner. If the data doesn't have the date information, you cannot use this function.

- 1 Press ▲ or ▼ to choose **Date Print**.
- 2 Press ◀ or ▶ to choose **On** (or **Off**). Press **OK**.
- 3 If you do not want to change additional settings, press **Colour Start** to print.



### Note

The DPOF setting on your camera must be turned off to use Date Print.

## Setting your changes as a new default

You can save the print settings you use most often by setting them as the default settings. These settings will stay until you change them again.

- 1 Press ▲ or ▼ to choose your new setting. Press **OK**. Repeat this step for each setting you want to change.
- 2 After changing the last setting, press ▲ or ▼ to choose `Set New Default`. Press **OK**.
- 3 Press **1** to choose `Yes`.
- 4 Press **Stop/Exit**.

## Restoring all settings to the factory settings

You can restore all the settings you have changed to the factory settings. These settings will stay until you change them again.

- 1 Press ▲ or ▼ to choose `Factory Reset`. Press **OK**.
- 2 Press **1** to choose `Yes`.
- 3 Press **Stop/Exit**.

## Scan to a memory card or USB Flash memory drive

### Entering Scan mode

When you want to scan to a memory card or USB Flash memory drive, press

 (**Scan**).

The LCD shows:

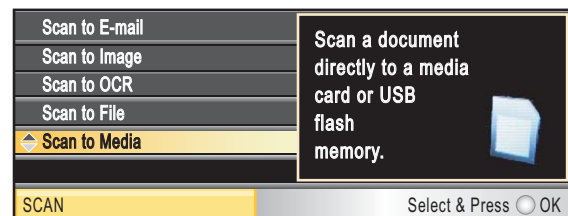

Press ▲ or ▼ to choose `Scan to Media`.

Press **OK**.

If you are not connected to your computer only the `Scan to Media` selection will appear on the LCD.

(See *Scanning for Windows*<sup>®</sup> or *Macintosh*<sup>®</sup> in the Software User's Guide on the CD-ROM for details about the other menu options.)

## How to scan to a memory card or USB Flash memory drive

You can scan monochrome and colour documents onto a memory card or USB Flash memory drive. Monochrome documents will be stored in PDF (\*.PDF) or TIFF (\*.TIF) file formats. Colour documents may be stored in PDF (\*.PDF) or JPEG (\*.JPG) file formats. The factory setting is `Color 150 dpi` and the default file format is PDF. The machine automatically creates file names based on the current date. (For details, see the Quick Setup Guide.) For example, the fifth image scanned on July 1, 2009 would be named 01070905.PDF. You can change the colour and quality.

Quality	Selectable File Format
Color 150 dpi	JPEG / PDF
Color 300 dpi	JPEG / PDF
Color 600 dpi	JPEG / PDF
B/W 200x100 dpi	TIFF / PDF
B/W 200 dpi	TIFF / PDF

- 1 Insert a CompactFlash®, Memory Stick®, Memory Stick Pro™, SD, SDHC, xD-Picture Card™ or USB Flash memory drive into your machine.

### CAUTION

DO NOT take out the memory card while **Photo Capture** is blinking to avoid damaging the card or data stored on the card.

- 2 Load your document.
- 3 Press  (**Scan**).
- 4 Press ▲ or ▼ to choose **Scan to Media**. Press **OK**.
- 5 Do one of the following:
  - To change the quality, press ▲ or ▼ to choose **Quality**. Go to step 6.
  - Press **Mono Start** or **Colour Start** to start scanning without changing additional settings.

### Note

(MFC-6490CW only)  
If you are using the scanner glass of the machine you can change the glass scan size.  
Press ▲ or ▼ to choose **Glass ScanSize** and ◀ or ▶ to choose **A4, A3, Letter, Legal** or **Ledger**.

- 6 Press ◀ or ▶ to choose  
Color 150 dpi, Color 300 dpi,  
Color 600 dpi, B/W 200x100 dpi  
or B/W 200 dpi.  
Press **OK**.
- 7 Do one of the following:
  - To change the file type, go to step 8.
  - Press **Mono Start** or **Colour Start** to start scanning without changing additional settings.
- 8 Press ▲ or ▼ to choose **File Type**. Press ◀ or ▶ to choose **JPEG, PDF** or **TIFF**. Press **OK**.

### Note

- If you chose colour in the resolution setting, you cannot choose **TIFF**.
- If you chose monochrome in the resolution setting, you cannot choose **JPEG**.

- 9 Do one of the following:
  - To change the file name, go to step 10.
  - Press **Mono Start** or **Colour Start** to start scanning without changing additional settings.
- 10 The file name is set automatically however, you can set a name of your choice using the dial pad. Press ▲ or ▼ to choose **File Name**. Enter the new name. (See *Entering Text* on page 194.) You can only change the first 6 characters. Press **OK**.

### Note

Press **Clear/Back** to delete the current name.

- 11 Press **Mono Start** or **Colour Start**.

## Glass Scan Size (MFC-6490CW only)

To scan a Letter, Legal, Ledger, or A3 size document, you need to change the `Glass ScanSize` setting. The default setting is A4.

- 1 Press  (**Scan**).
- 2 Press ▲ or ▼ to choose `Scan to Media`. Press **OK**.
- 3 Press ▲ or ▼ to choose `Glass ScanSize`.
- 4 Press ◀ or ▶ to choose `A4`, `A3`, `Letter`, `Legal` or `Ledger`.



### Note

- You can save the setting you use most often by setting it as the default. (See *Setting your changes as a new default* on page 114.)
- This setting is only available for scanning documents from the scanner glass.

## How to change the file name

You can change the file name.

- 1 Press  (**Scan**).
- 2 Press ▲ or ▼ to choose `Scan to Media`. Press **OK**.
- 3 Press ▲ or ▼ to choose `File Name`.
- 4 Enter the new name using the dial pad. You can only change the first 6 digits. (See *Entering Text* on page 194.)

## How to set a new default

You can set your own default setting.

- 1 Press  (**Scan**).
- 2 Press ▲ or ▼ to choose `Scan to Media`. Press **OK**.
- 3 Press ▲ or ▼ to choose `Set New Default`. Press **OK** and **1** to choose `Yes`.
- 4 Press **Stop/Exit**.

## How to reset to factory settings

You can restore the machine to factory settings.

- 1 Press  (**Scan**).
- 2 Press ▲ or ▼ to choose `Scan to Media`. Press **OK**.
- 3 Press ▲ or ▼ to choose `Factory Reset`. Press **OK** and **1** to choose `Yes`.
- 4 Press **Stop/Exit**.

## Understanding the Error Messages

Once you are familiar with the types of errors that can occur while you are using PhotoCapture Center™, you can easily identify and troubleshoot any problems.

### ■ Hub is Unusable.

This message will appear if a Hub or USB Flash memory drive with a Hub has been put into the USB direct interface.

### ■ Media Error

This message will appear if you put in a memory card that is either bad or not formatted, or when there is a problem with the media drive. To clear this error, take out the memory card.

### ■ No File

This message will appear if you try to access a memory card or USB Flash memory drive in the drive (slot) that does not contain a .JPG file.

### ■ Out of Memory

This message will appear if you are working with images that are too large for the machine's memory. This message will also appear when a memory card or USB Flash memory drive you are using does not have enough space available for the scanned document.

### ■ Media is Full.

This message will appear if you are trying to save more than 999 files in a memory card or USB Flash memory drive.

### ■ Unusable Device

This message will appear if a USB device or USB Flash memory drive that is not supported has been connected to the USB direct interface. For more information, visit us at <http://solutions.brother.com>. This message will also appear if you connect a broken device to the USB direct interface.

## Printing photos directly from a PictBridge camera



Your Brother machine supports the PictBridge standard, allowing you to connect to and print photos directly from any PictBridge compatible digital camera.

If your camera is using the USB Mass Storage standard, you can also print photos from a digital camera without PictBridge. (See *Printing photos directly from a digital camera (without PictBridge)* on page 120.)

### PictBridge requirements

To avoid errors, remember the following points:

- The machine and the digital camera must be connected using a suitable USB cable.
- The image file extension must be .JPG (other image file extensions like .JPEG, .TIF, .GIF and so on will not be recognized).
- PhotoCapture Center™ operations are not available when using the PictBridge feature.

### Setting your digital camera

Make sure your camera is in PictBridge mode. The following PictBridge settings may be available from the LCD of your PictBridge compatible camera.

Depending on your camera some of these settings may not be available.

Camera Menu Selections	Options
Paper Size	Ledger, A3, Letter, A4, 10x15cm, Printer Settings (Default setting) <sup>2</sup>
Paper Type	Plain Paper, Glossy Paper, Inkjet Paper, Printer Settings (Default setting) <sup>2</sup>
Layout	Borderless: On, Borderless: Off, Printer Settings (Default setting) <sup>2</sup>
DPOF setting <sup>1</sup>	-
Print Quality	Normal, Fine, Printer Settings (Default setting) <sup>2</sup>
Color Enhancement	On, Off, Printer Settings (Default setting) <sup>2</sup>
Date Print	On, Off, Printer Settings (Default setting) <sup>2</sup>

<sup>1</sup> See *DPOF printing* on page 119 for more details.

<sup>2</sup> If your camera is set to use the Printer Settings (Default setting), the machine will print your photo using the following settings.

Settings	Options
Paper Size	10x15cm
Paper Type	Glossy Paper
Layout	Borderless: On
Print Quality	Fine
Color Enhancement	Off
Date Print	Off

- When your camera does not have any menu selections, these settings are also used.
- The names and availability of each setting depends on the specification of your camera.

Please refer to the documentation supplied with your camera for more detailed information on changing PictBridge settings.

## Printing Images



### Note

Remove any memory cards or USB Flash memory drive from the machine before connecting a digital camera.

- 1 Make sure that your camera is turned off. Connect your camera to the USB direct interface (1) on the machine using the USB cable.

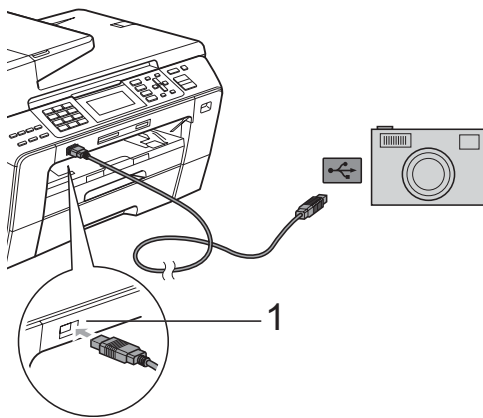

### 1 USB direct interface

- 2 Turn on the camera.  
When the machine has recognized the camera, the LCD shows `Camera Connected`.
- 3 Choose the photo you want to print following the instructions from your camera.  
When the machine starts printing a photo, the LCD will show `Printing`.



### CAUTION

To prevent damage to your machine, do not connect any device other than a digital camera or USB Flash memory drive to the USB direct interface.

## DPOF printing

DPOF stands for Digital Print Order Format.

Major digital camera manufacturers (Canon Inc., Eastman Kodak Company, Fuji Photo Film Co. Ltd., Matsushita Electric Industrial Co. Ltd. and Sony Corporation) created this standard to make it easier to print images from a digital camera.

If your digital camera supports DPOF printing, you will be able to choose on the digital camera display the images and number of copies you want to print.



### Note

An Invalid DPOF File error can occur if the print order that was created on the camera has been corrupted. Delete and recreate the print order using your camera to correct this problem. For instructions on how to delete or recreate the print order, refer to your camera manufacturer's support website or accompanying documentation.

## Printing photos directly from a digital camera (without PictBridge)

If your camera supports the USB Mass Storage standard, you can connect your camera in storage mode. This enables you to print photos from your camera.

(If you would like to print photos in PictBridge mode, see *Printing photos directly from a PictBridge camera* on page 118.)

### Note

The name, availability and operation differ among digital cameras. Please refer to the documentation supplied with your camera for detailed information, such as how to switch from PictBridge mode to USB mass storage mode.

## Printing Images

### Note

Remove any memory cards or USB Flash memory drive from the machine before connecting a digital camera.

- 1 Make sure that your camera is turned off. Connect your camera to the USB direct interface (1) on the machine using the USB cable.

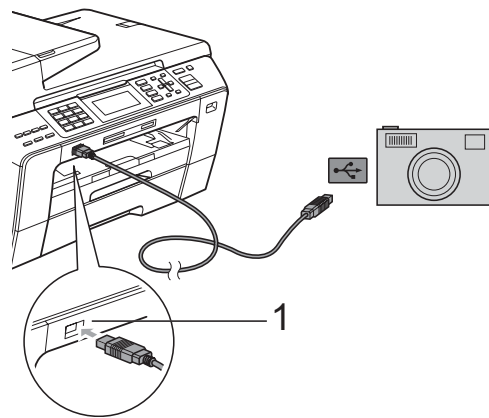

1 USB direct interface

- 2 Turn on the camera.
- 3 Follow the steps in *Print Images* on page 103.

### CAUTION

To prevent damage to your machine, do not connect any device other than a digital camera or USB Flash memory drive to the USB direct interface.

## Understanding the Error Messages

Once you are familiar with the types of errors that can occur while you are printing from a camera, you can easily identify and troubleshoot any problems.

- Out of Memory

This message will appear if you are working with images that are too large for the machine's memory.

- Unusable Device

This message will appear if you connect a camera which is not using the USB Mass Storage standard. This message will also appear if you connect a broken device to the USB direct interface.

(For more detailed solutions see *Error and Maintenance messages* on page 144.)





# Software

---

Software and Network features

124

# 14

## Software and Network features

The CD-ROM includes the Software User's Guide and Network User's Guide for features available when connected to a computer (for example, printing and scanning). These guides have easy to use links that, when clicked, will take you directly to a particular section.

You can find information on these features:

- Printing
- Scanning
- ControlCenter3 (for Windows®)
- ControlCenter2 (for Macintosh®)
- Remote Setup
- Faxing from your computer
- PhotoCapture Center™
- Network Printing
- Network Scanning
- Wired and Wireless Network (MFC-6490CW only)

### How to read HTML User's Guide

This is a quick reference for using the HTML User's Guide.

#### For Windows®



#### Note

If you have not installed the software, see *Viewing Documentation* on page 3.

- 1 From the **Start** menu, point to **Brother**, **MFC-XXXX** (where XXXX is your model number) from the programs group, then click **User's Guides in HTML format**.
- 2 Click **SOFTWARE USER'S GUIDE** (or **NETWORK USER'S GUIDE**) from the top menu.



- 3 Click the heading you would like to view from the list at the left of the window.

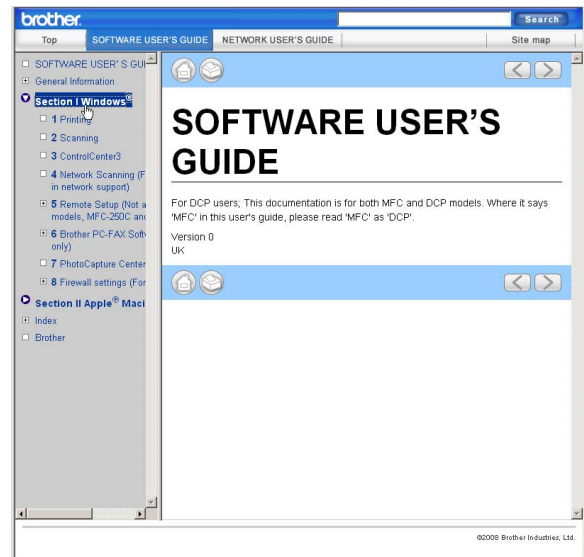

#### For Macintosh®

- 1 Make sure your Macintosh® is turned on. Insert the Brother CD-ROM into your CD-ROM drive.
- 2 Double-click the **Documentation** icon.
- 3 Double-click your language folder, and then double-click top.html.
- 4 Click **SOFTWARE USER'S GUIDE** (or **NETWORK USER'S GUIDE**) in the top menu, and then click the heading you would like to read from the list at the left of the window.

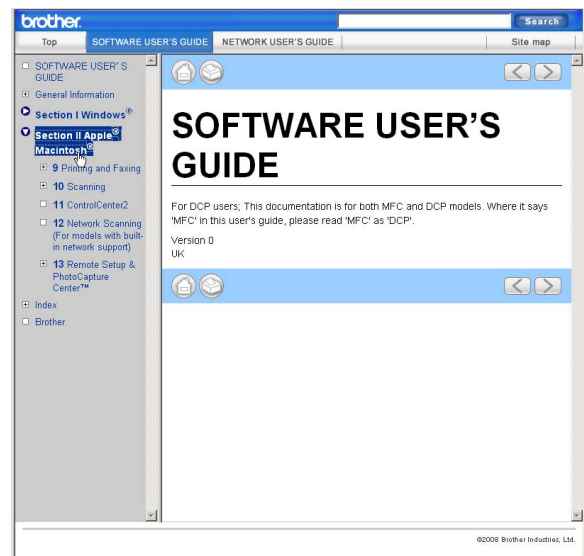



# Appendixes

---

<b>Safety and Legal</b>	126
<b>Troubleshooting and Routine Maintenance</b>	136
<b>Menu and Features</b>	168
<b>Specifications</b>	195
<b>Glossary</b>	210

# A

## Safety and Legal

### Choosing a location

Put your machine on a flat, stable surface that is free of vibration and shocks, such as a desk. Put the machine near a telephone socket and a standard grounded electrical socket. Choose a location where the temperature remains between 10° C and 35° C.



#### WARNING

DO NOT put the machine near heaters, air conditioners, refrigerators, medical equipment, chemicals or water.

DO NOT connect your machine to electrical sockets on the same circuit as large appliances or other equipment that might disrupt the power supply.



#### CAUTION

- Avoid placing your machine in a high-traffic area.
- Avoid placing your machine on a carpet.
- DO NOT expose the machine to direct sunlight, excessive heat, moisture, or dust.
- DO NOT connect your machine to electrical sockets controlled by wall switches or automatic timers.
- Disruption of power can wipe out information in the machine's memory.
- Avoid interference sources, such as other cordless telephone systems or speakers.
- DO NOT tip the machine, or place it on any tilted surface. Doing this may cause ink spillage and internal damage to your machine.



## To use the machine safely

Please keep these instructions for later reference and read them before attempting any maintenance.

### Note

If there are faxes in the machine's memory, you need to print them or save them before you unplug the machine from the AC power outlet for more than 24 hours. (To print the faxes in memory, see *Printing a fax from the memory* on page 54. To save the faxes in memory, see *Transferring faxes to another fax machine* on page 150 or *Transferring faxes to your PC* on page 150.)



### WARNING



There are high voltage electrodes inside the machine. Before you clean the inside of the machine, make sure you have unplugged the telephone line cord first and then the power cord from the electrical socket. Doing this will prevent an electrical shock.

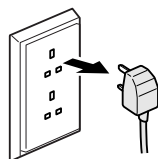

DO NOT handle the plug with wet hands. Doing this might cause an electrical shock.

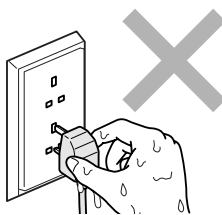

DO NOT pull on the middle of the AC power cord. Doing this might cause an electrical shock.



DO NOT put your hands on the edge of the machine under the document cover or the scanner cover. Doing this may cause injury.

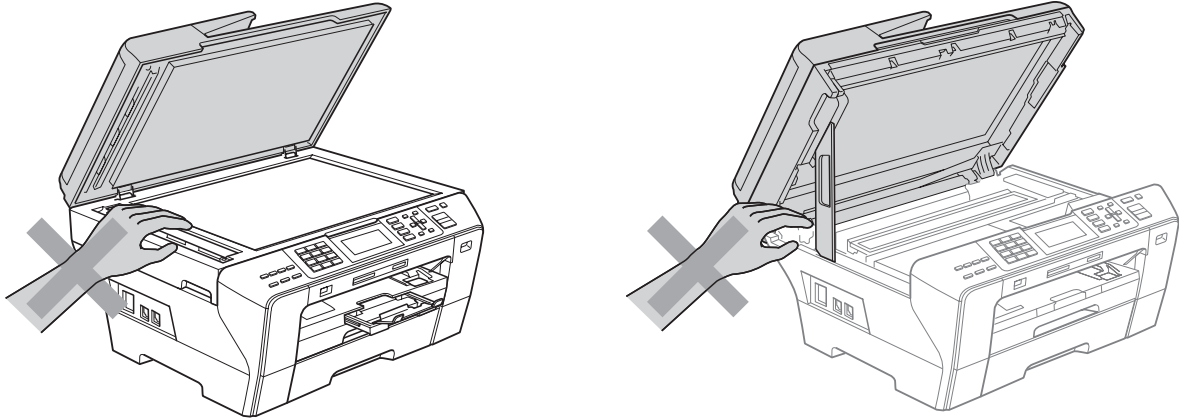

DO NOT put your hands in front of the machine under the scanner cover. Doing this may cause injury.

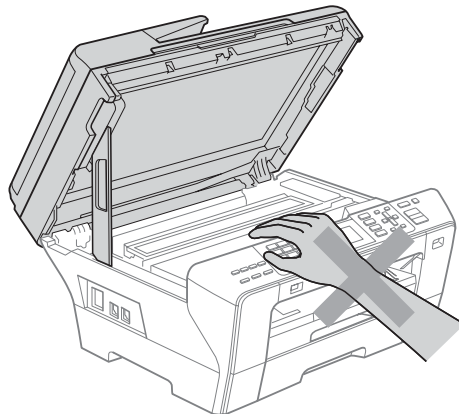

DO NOT put your hands on the edge of the paper tray under the paper tray cover. Doing this may cause injury.

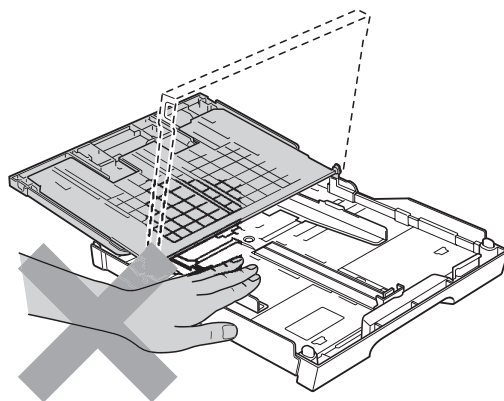



DO NOT touch the area shaded in the illustration. Doing this may cause injury.

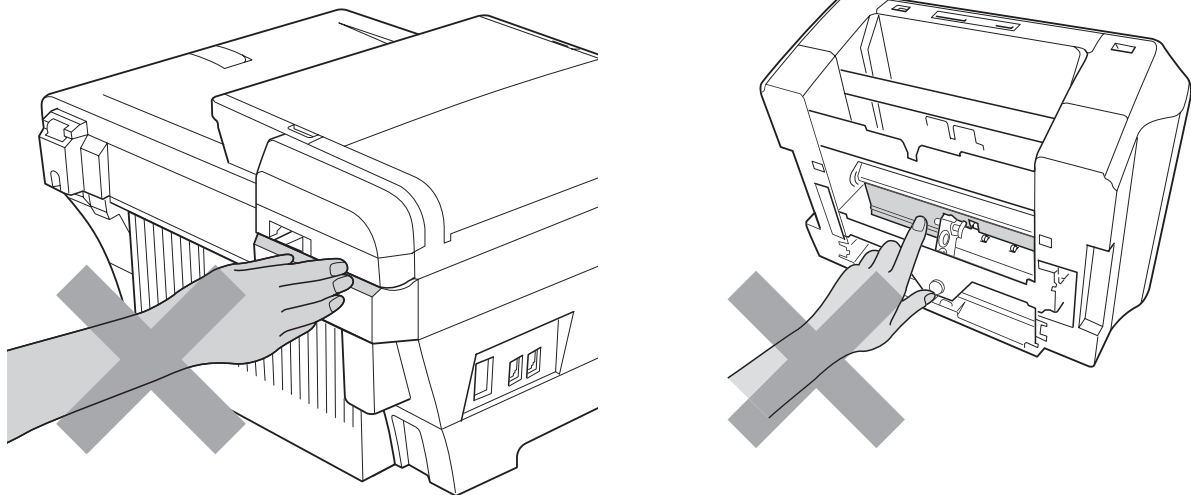

When moving the machine you must lift it from the base, by placing a hand at each side of the unit as shown in the illustration. DO NOT carry the machine by holding the scanner cover or the Jam Clear Cover.



DO NOT use flammable substances, any type of spray, liquid or aerosol cleaners to clean the inside or outside of the machine. Doing this may cause a fire or electrical shock.





If the machine becomes hot, releases smoke, or generates any strong smells, immediately unplug the machine from the electrical socket. Call your Brother dealer or Brother Customer Service.

---



If metal objects, water or other liquids get inside the machine, immediately unplug the machine from the electrical socket. Call your Brother dealer or Brother Customer Service.

---



Use caution when installing or modifying telephone lines. Never touch telephone wires or terminals that are not insulated unless the telephone line has been unplugged at the wall socket. Never install telephone wiring during a lightning storm. Never install a telephone wall socket in a wet location.

---



This product must be installed near an electrical socket that is easily accessible. In case of an emergency, you must unplug the power cord from the electrical socket to shut off the power completely.

---



This product should be connected to an AC power source within the range indicated on the rating label. DO NOT connect it to a DC power source or inverter. If you are not sure, contact a qualified electrician.

---



Always make sure the plug is fully inserted.

---



DO NOT use the machine if the power cord is frayed or damaged, doing so may cause a fire.



When using your telephone equipment, basic safety precautions should always be followed to reduce the risk of fire, electric shock and injury to people, including the following:

- 1 DO NOT use this product near water, for example, near a bath tub, wash bowl, kitchen sink or washing machine, in a wet basement or near a swimming pool.
- 2 Avoid using this product during an electrical storm. There may be a remote risk of electric shock from lightning.
- 3 DO NOT use this product to report a gas leak in the vicinity of the leak.
- 4 DO NOT dispose of batteries in a fire. They may explode. Check with local codes for possible special disposal instructions.

## Important safety instructions

- 1 Read all of these instructions.
- 2 Save them for later reference.
- 3 Follow all warnings and instructions marked on the product.
- 4 DO NOT use this product near water.
- 5 DO NOT place this product on an unstable cart, stand, or table. The product may fall, causing serious damage to the product.
- 6 Slots and openings in the cabinet and the back or bottom are provided for ventilation. To ensure reliable operation of the product and to protect it from overheating, these openings must not be blocked or covered. The openings should never be blocked by placing the product on a bed, sofa, rug, or other similar surface. This product should never be placed near or over a radiator or heater. This product should never be placed in a built-in installation unless adequate ventilation is provided.
- 7 Use only the power cord supplied with this machine.
- 8 This product is equipped with a 3-wire grounded plug, a plug having a third (grounded) pin. This plug will only fit into a grounded power outlet. This is a safety feature. If you are unable to insert the plug into the outlet, call your electrician to replace your obsolete outlet. DO NOT defeat the purpose of the grounded plug.
- 9 DO NOT allow anything to rest on the power cord. DO NOT place this product where people can walk on the cord.
- 10 DO NOT place anything in front of the machine that will block received faxes. DO NOT place anything in the path of received faxes.
- 11 Wait until pages have exited the machine before picking them up.

12 Unplug this product from the power socket and refer all servicing to Brother Authorized Service Personnel under the following conditions:

- If liquid has been spilled into the product.
- If the product has been exposed to rain or water.
- If the product does not operate normally when the operating instructions are followed, adjust only those controls that are covered by the operating instructions. Incorrect adjustment of other controls may result in damage and will often require extensive work by a qualified technician to restore the product to normal operation.
- If the product has been dropped or the casing has been damaged.
- If the product exhibits a distinct change in performance, indicating a need for service.

13 To protect your product against power surges, we recommend the use of a power protection device (Surge Protector).

14 To reduce the risk of fire, electric shock and injury to people, note the following:

- DO NOT use this product near appliances that use water, a swimming pool, or in a wet basement.

## **IMPORTANT - For your safety**

---

To ensure safe operation, the supplied three-pin plug must be inserted only into a standard three-pin electrical socket that is effectively grounded through the normal household wiring.

The fact that the equipment operates satisfactorily does not imply that the power is grounded and that the installation is completely safe. For your safety, if in any doubt about the effective grounding of the power, consult a qualified electrician.

### **Important - Wiring information (U.K. only)**

If you need to replace the plug fuse, fit a fuse that is approved by ASTA to BS1362 with the same rating as the original fuse.

Always replace the fuse cover. Never use a plug that does not have a cover.

### **Warning - This machine must be earthed.**

The wires in the mains lead are coloured in line with the following code:

- **Green and Yellow: Earth**
- **Blue: Neutral**
- **Brown: Live**

If in any doubt, call a qualified electrician.

## LAN connection

### ! CAUTION

DO NOT connect this product to a LAN connection that is subject to over-voltages.

## Radio interference

This product complies with EN55022 (CISPR Publication 22) /Class B. When connecting the machine to a computer, ensure that you use a USB cable which does not exceed 2.0 m in length.

## EU Directive 2002/96/EC and EN50419



European  
Union Only

This equipment is marked with the above recycling symbol. It means that at the end of the life of the equipment you must dispose of it separately at an appropriate collection point and not place it in the normal domestic unsorted waste stream. This will benefit the environment for all.  
(European Union only)

## International ENERGY STAR® Compliance Statement

The purpose of the International ENERGY STAR® Program is to promote the development and popularization of energy-efficient office equipment.

As an ENERGY STAR® Partner, Brother Industries, Ltd. has determined that this product meets the ENERGY STAR® guidelines for energy efficiency.



## Legal limitations for copying

It is an offence to make reproductions of certain items or documents with the intent to commit fraud. This memorandum is intended to be a guide rather than a complete list. We suggest you check with relevant legal authorities if in doubt about a particular item or document.

The following are examples of documents which may not be copied:

- Money
- Bonds or other certificates of indebtedness
- Certificates of Deposit
- Armed Forces Service or Draft papers.
- Passports
- Postage Stamps (cancelled or uncanceled)
- Immigration Papers
- Welfare documents
- Cheques or Drafts drawn by Governmental Agencies
- Identification Documents, badges or insignias

Copyrighted works cannot be copied. Sections of a copyrighted work can be copied for 'fair dealing'. Multiple copies would indicate improper use.

Works of art should be considered the equivalent of copyrighted works.

Licenses and Certificates of Title to motor vehicles may not be copied under certain state/provincial laws.

# Trademarks

The Brother logo is a registered trademark of Brother Industries, Ltd.

Brother is a registered trademark of Brother Industries, Ltd.

Multi-Function Link is a registered trademark of Brother International Corporation.

© 2008 Brother Industries, Ltd. All rights reserved.

Windows Vista is either a registered trademark or a trademark of Microsoft Corporation in the United States and other countries.

Microsoft, Windows and Windows Server are registered trademarks of Microsoft Corporation in the United States and/or other countries.

Macintosh and TrueType are registered trademarks of Apple Inc.

Nuance, the Nuance logo, PaperPort and ScanSoft are trademarks or registered trademarks of Nuance Communications, Inc. or its affiliates in the United States and/or other countries.

Presto! PageManager is a registered trademark of NewSoft Technology Corporation.

Microdrive is a trademark of International Business Machines Corporation.

CompactFlash is a registered trademark of SanDisk Corporation.

Memory Stick is a registered trademark of Sony Corporation.

SanDisk is a licensee of the SD and miniSD trademarks.

xD-Picture Card is a trademark of Fujifilm Co. Ltd., Toshiba Corporation and Olympus Optical Co. Ltd.

PictBridge is a trademark.

Memory Stick Pro, Memory Stick Pro Duo, Memory Stick Duo and MagicGate are trademarks of Sony Corporation.

BROADCOM, SecureEasySetup and the SecureEasySetup logo are trademarks or registered trademarks of Broadcom Corporation in the United States and/or other countries.

AOSS is a trademark of Buffalo Inc.

Wi-Fi, WPA and WPA2 are registered trademarks and Wi-Fi Protected Setup is a trademark of Wi-Fi Alliance.

FaceFilter Studio is a trademark of Reallusion, Inc.

Each company whose software title is mentioned in this manual has a Software License Agreement specific to its proprietary programs.

**All other brand and product names mentioned in this User's Guide are registered trademarks of their respective companies.**

# B

# Troubleshooting and Routine Maintenance

## Troubleshooting

If you think there is a problem with your machine, check the chart below and follow the troubleshooting tips.

Most problems can be easily resolved by yourself. If you need additional help, the Brother Solutions Center offers the latest FAQs and troubleshooting tips. Visit us at <http://solutions.brother.com>.

### If you are having difficulty with your machine

#### Printing

Difficulty	Suggestions
No printout	Check the interface cable on both the machine and your computer. (See the <i>Quick Setup Guide</i> .)
	Make sure the machine is plugged in and not in Power Save mode.
	Check to see if the LCD is showing an error message. (See <i>Error and Maintenance messages</i> on page 144.)
	If the LCD says <code>Cannot Print and Replace Ink</code> , see <i>Replacing the ink cartridges</i> on page 157.
	Check that the correct printer driver has been installed and chosen.
	Make sure that the machine is online. Click <b>Start</b> and then <b>Printers and Faxes</b> . Choose <b>Brother MFC-XXXX</b> (where XXXX is your model name), and make sure that <b>Use Printer Offline</b> is unchecked.
	When you choose the <b>Print Odd Pages</b> and <b>Print Even Pages</b> settings, you may see a print error message on your computer, as the machine pauses during the printing process. The error message will disappear after the machine re-starts printing.
Poor print quality	Check the print quality. (See <i>Checking the print quality</i> on page 163.)
	Make sure that the Media Type setting in the printer driver or the Paper Type setting in the machine's menu matches the type of paper you are using. (See <i>Printing for Windows</i> ® or <i>Printing and Faxing for Macintosh</i> ® in the Software User's Guide on the CD-ROM and <i>Paper Size and Type (MFC-6490CW only)</i> on page 27.)
	Make sure that your ink cartridges are fresh. The following may cause ink to clog: <ul style="list-style-type: none"> <li>■ The expiration date written on the cartridge package has passed. (Brother Original cartridges stay usable for up to two years if kept in their original packaging.)</li> <li>■ The ink cartridge was in your machine over six months.</li> <li>■ The ink cartridge may not have been stored correctly before use.</li> </ul>
	Make sure that you are using Brother Original Innobella™ ink.
	Try using the recommended types of paper. (See <i>Acceptable paper and other print media</i> on page 18.)
	The recommended environment for your machine is between 20° C to 33° C.

## Printing (continued)

Difficulty	Suggestions
White horizontal lines appear in text or graphics.	Clean the print head. (See <i>Cleaning the print head</i> on page 162.)
	Make sure that you are using Brother Original Innobella™ ink.
	Try using the recommended types of paper. (See <i>Acceptable paper and other print media</i> on page 18.)
	If you are using A3 long grain paper, you may get horizontal lines appearing on your prints. Try turning off A3 Secure Feed. (See <i>Secure Paper Feed mode for A3 size Short Grain Paper</i> on page 29.) If you are printing from a computer, change the paper size to <b>A3 (Long Grain)</b> in the driver. (See <i>Printing for Windows®</i> or <i>Printing and Faxing for Macintosh®</i> in the Software User's Guide on the CD-ROM.)
The machine prints blank pages.	Clean the print head. (See <i>Cleaning the print head</i> on page 162.)
	Make sure that you are using Brother Original Innobella™ ink.
Characters and lines are stacked.	Check the printing alignment. (See <i>Checking the print alignment</i> on page 164.)
Printed text or images are skewed.	Make sure the paper is loaded correctly in the paper tray and the paper side guides are adjusted correctly. (See <i>Loading paper and other print media</i> on page 9.)
	(MFC-6490CW) Make sure the Outer Rear Cover and Inner Rear Cover are closed correctly.
	(MFC-5890CN) Make sure the Jam Clear Cover is closed correctly.
Smudged stain at the top centre of the printed page.	Make sure the paper is not too thick or curled. (See <i>Acceptable paper and other print media</i> on page 18.)
Smudged stain at the right or left corner of the printed page.	Make sure the paper is not curled when you print on the back side of the paper with the <b>Print Odd Pages</b> and <b>Print Even Pages</b> settings.
Printing appears dirty or ink seems to run.	Make sure you are using the recommended types of paper. (See <i>Acceptable paper and other print media</i> on page 18.) Don't handle the paper until the ink is dry.
	Make sure that you are using Brother Original Innobella™ ink.
	If you are using photo paper, make sure that you have set the correct paper type. If you are printing a photo from your PC, set the <b>Media Type</b> in the <b>Basic</b> tab of the printer driver.
Stains appear on the reverse side or at the bottom of the page.	Make sure the printer platen is not dirty with ink. (See <i>Cleaning the machine printer platen</i> on page 161.)
	Make sure that you are using Brother Original Innobella™ ink.
	Make sure you are using the paper support flap. (See <i>Loading paper and other print media</i> on page 9.)
The machine prints dense lines on the page.	Check <b>Reverse Order</b> in the <b>Basic</b> tab of the printer driver.
The printouts are wrinkled.	In the printer driver <b>Advanced</b> tab, click <b>Colour Settings</b> , and uncheck <b>Bi-Directional Printing</b> for Windows® or <b>Bi-Directional Printing</b> for Macintosh®.
	Make sure that you are using Brother Original Innobella™ ink.
Cannot perform 'Page Layout' printing.	Check that the paper size setting in the application and in the printer driver are the same.

B

## Printing (continued)

Difficulty	Suggestions
Print speed is too slow.	Try changing the printer driver setting. The highest resolution needs longer data processing, sending and printing time. Try the other quality settings in the printer driver <b>Advanced</b> tab. Also, click <b>Colour Settings</b> , and make sure you uncheck <b>Colour Enhancement</b> .
	Turn the borderless feature off. Borderless printing is slower than normal printing. (See <i>Printing for Windows®</i> or <i>Printing and Faxing for Macintosh®</i> in the Software User's Guide on the CD-ROM.)
Colour Enhancement is not working correctly.	If the image data is not full colour in your application (such as 256 colour), Colour Enhancement will not work. Use at least 24 bit colour data with the Colour Enhancement feature.
Photo paper does not feed properly.	When you print on Brother Photo paper, load one extra sheet of the same photo paper in the paper tray. An extra sheet has been included in the paper package for this purpose.
	Clean the paper pick-up roller. (See <i>Cleaning the paper pick-up roller</i> on page 162.)
Machine feeds multiple pages.	Make sure the paper is loaded correctly in the paper tray. (See <i>Loading paper and other print media</i> on page 9.)
	Check that more than two types of paper are not loaded in the paper tray at any one time.
Printed pages are not stacked neatly.	Make sure you are using the paper support flap. (See <i>Loading paper and other print media</i> on page 9.)
Machine does not print from Adobe Illustrator.	Try to reduce the print resolution. (See <i>Printing for Windows®</i> or <i>Printing and Faxing for Macintosh®</i> in the Software User's Guide on the CD-ROM.)

## Printing Received Faxes

Difficulty	Suggestions
Condensed print and white streaks across the page or the top and bottom of sentences are cut off.	You probably had a bad connection, with static or interference on the telephone line. Ask the other party to send the fax again.
Vertical black lines when receiving.	The sender's scanner may be dirty. Ask the sender to make a copy to see if the problem is with the sending machine. Try receiving from another fax machine.
Received colour fax prints only in black and white.	Replace the colour ink cartridges that are empty or nearly empty, and then ask the other person to send the colour fax again. (See <i>Replacing the ink cartridges</i> on page 157.)
	Check that Setup Receive is set to Colour(Max.A4). (See <i>Setting Receiving Priority</i> on page 53.)
Left and Right margins are cut off or a single page is printed on two pages.	Turn on Auto Reduction. (See <i>Printing a reduced incoming fax</i> on page 52.)

## Telephone Line or Connections

Difficulty	Suggestions
Dialling does not work. (No dial tone)	Make sure the machine is plugged in and not in Power Save mode.
	Check the line cord connections.
	Change the Tone/Pulse setting. (See the <i>Quick Setup Guide</i> .)
	Lift the external telephone's handset, (or the machine's handset or cordless handset if available), and then dial the number to send a manual fax. Wait to hear fax receiving tones before pressing <b>Mono Start</b> or <b>Colour Start</b> .
The machine does not answer when called.	Make sure the machine is in the correct receiving mode for your setup. (See <i>Choose the Receive Mode</i> on page 49.) Check for a dial tone. If possible, call your machine to hear it answer. If there is still no answer, check the telephone line cord connection. If there is no ringing when you call your machine, ask your telephone company to check the line.

## Receiving Faxes

Difficulty	Suggestions
Cannot receive a fax.	Check all line cord connections.
	Make sure the machine is in the correct receiving mode for your setup. (See <i>Receive mode settings</i> on page 51.)
	If you often have interference on the telephone line, try changing the menu setting of Compatibility to <i>Basic (for VoIP)</i> . (See <i>Telephone line interference</i> on page 143.)
	If you connect your machine to PBX or ISDN, set the menu setting of Telephone Line Type to your telephone type. (See <i>Setting the Telephone Line Type</i> on page 66.)

## Sending Faxes

Difficulty	Suggestions
Cannot send a fax.	Check all line cord connections.
	Make sure that the Fax  key is illuminated. (See <i>Entering Fax mode</i> on page 40.)
	Ask the other party to check that the receiving machine has paper.
	Print the Transmission Verification Report and check for an error. (See <i>Reports</i> on page 83.)
Transmission Verification Report says 'Result:ERROR'.	There is probably temporary noise or static on the line. Try sending the fax again. If you send a PC FAX message and get 'Result:ERROR' on the Transmission Verification Report, your machine may be out of memory. To gain extra memory, you can turn off Memory Receive (see <i>Turning off Memory Receive Operations</i> on page 57), print fax messages in memory (see <i>Memory Receive (Monochrome only)</i> on page 54) or cancel a Delayed Fax or Polling Job (see <i>Cancelling a fax in progress</i> on page 42 or <i>Checking and cancelling waiting jobs</i> on page 47). If the problem continues, ask the telephone company to check your telephone line.
	If you often get transmission errors due to possible interference on the telephone line, try changing the menu setting of Compatibility to <i>Basic (for VoIP)</i> . (See <i>Telephone line interference</i> on page 143.)
	If you connect your machine to PBX or ISDN, set the menu setting of Telephone Line Type to your telephone type. (See <i>Setting the Telephone Line Type</i> on page 66.)

## Sending Faxes (continued)

Difficulty	Suggestions
Poor fax send quality.	Try changing your resolution to <i>Fine</i> or <i>S. Fine</i> . Make a copy to check your machine's scanner operation. If the copy quality is not good, clean the scanner. (See <i>Cleaning the scanner glass</i> on page 161.)
Vertical black lines when sending.	Black vertical lines on faxes you send are typically caused by dirt or correction fluid on the glass strip. Clean the glass strip. (See <i>Cleaning the scanner glass</i> on page 161.)

## Handling Incoming Calls

Difficulty	Suggestions
The machine 'Hears' a voice as a CNG Tone.	If Fax Detect is set to on, your machine is more sensitive to sounds. It may mistakenly interpret certain voices or music on the line as a fax machine calling and respond with fax receiving tones. Deactivate the machine by pressing <b>Stop/Exit</b> . Try avoiding this problem by turning Fax Detect to off. (See <i>Fax Detect</i> on page 52.)
Sending a fax call to the machine.	If you answered on an external or extension telephone, press your Remote Activation Code (the factory setting is * 5 1). When your machine answers, hang up.
Custom features on a single line.	If you have Call Waiting, Call Waiting/Caller ID, an alarm system or other custom feature on a single telephone line with your machine, it may create a problem sending or receiving faxes.  <b>For example:</b> If you subscribe to Call Waiting or some other custom service and its signal comes through the line while your machine is sending or receiving a fax, the signal can temporarily interrupt or disrupt the faxes. Brother's ECM (Error Correction Mode) feature should help overcome this problem. This condition is related to the telephone system industry and is common to all devices that send and receive information on a single, shared line with custom features. If avoiding a slight interruption is crucial to your business, a separate telephone line with no custom features is recommended.

## Copying Difficulties

Difficulty	Suggestions
Cannot make a copy.	Make sure that the Copy  key is illuminated. (See <i>Entering Copy mode</i> on page 88.)
Poor copy results when using the ADF.	Try using the scanner glass. (See <i>Using the scanner glass</i> on page 23.)
Vertical black lines or streaks appear in copies.	Vertical black lines or streaks on copies are typically caused by dirt or correction fluid on the glass strip. Clean the glass strip. (See <i>Cleaning the scanner glass</i> on page 161.)
Fit to Page does not work properly.	Make sure your source document is not skewed. Reposition the document and try again.

## Scanning Difficulties

Difficulty	Suggestions
TWAIN/WIA errors appear when starting to scan.	Make sure the Brother TWAIN/WIA driver is chosen as the primary source. In PaperPort™ 11SE with OCR, click <b>File, Scan or Get Photo</b> and click <b>Select</b> to choose the Brother TWAIN/WIA driver.
Poor scanning results when using the ADF.	Try using the scanner glass. (See <i>Using the scanner glass</i> on page 23.)
OCR does not work.	Try increasing the scanner resolution.

## Software Difficulties

Difficulty	Suggestions
Cannot install software or print.	Run the <b>Repair MFL-Pro Suite</b> program on the CD-ROM. This program will repair and reinstall the software.
'Device Busy'	Make sure the machine is not showing an error message on the LCD.
Cannot print images from FaceFilter Studio.	To use FaceFilter Studio, you must install the FaceFilter Studio application from the CD-ROM supplied with your machine. To install FaceFilter Studio see the <i>Quick Setup Guide</i> .  Also, before you start FaceFilter Studio for the first time, you must make sure your Brother machine is turned On, and connected to your computer. This will allow you to access all the functions of FaceFilter Studio.

## PhotoCapture Center™ Difficulties

Difficulty	Suggestions
Removable Disk does not work correctly.	<ol style="list-style-type: none"> <li>1 Have you installed the Windows® 2000 update? If not, do the following:                             <ol style="list-style-type: none"> <li>1) Unplug the USB cable.</li> <li>2) Install the Windows® 2000 update using one of the following methods.                                     <ul style="list-style-type: none"> <li>■ Install MFL-Pro Suite from the CD-ROM. (See the <i>Quick Setup Guide</i>.)</li> <li>■ Download the latest service pack from the Microsoft Web site.</li> </ul> </li> <li>3) Wait about 1 minute after you restart the PC, and then connect the USB cable.</li> </ol> </li> <li>2 Take out the memory card or USB Flash memory drive and put it back in again.</li> <li>3 If you have tried 'Eject' from within Windows®, take out the memory card or USB Flash memory drive before you continue.</li> <li>4 If an error message appears when you try to eject the memory card or USB Flash memory drive, it means the card is being accessed. Wait a while and then try again.</li> <li>5 If all of the above do not work, turn off your PC and machine, and then turn them on again. (You will have to unplug the power cord of the machine to turn it off.)</li> </ol>
Cannot access Removable Disk from Desktop icon.	Make sure that you have correctly inserted the memory card or USB Flash memory drive.
Part of my photo is missing when printed.	Make sure that Borderless Printing and Cropping are turned off. (See <i>Borderless printing</i> on page 113, and <i>Cropping</i> on page 113.)

## Network Difficulties

Difficulty	Suggestions
Cannot print over the Network.	<p>Make sure that your machine is powered on, is online and in Ready mode. Print a Network Configuration list (see <i>Reports</i> on page 83.) and check the current Network settings printed in this list. Reconnect the LAN cable to the hub to verify that the cabling and network connections are good. If possible, try connecting the machine to a different port on your hub using a different cable. If the connections are good, the machine shows LAN Active for 2 seconds.</p> <p>(If you are having Network problems, see the Network User's Guide for more information.)</p>
The network scanning feature does not work.	<p>(For Windows® users only) Firewall settings on your PC may be rejecting the necessary network connection. Follow the instructions below to configure the Firewall. If you are using personal Firewall software, see the User's Guide for your software or contact the software manufacturer.</p> <p>For Windows® XP SP2 and Windows Vista® users, see <i>Firewall settings</i> in the Software User's Guide on the CD-ROM.</p> <p>For Windows® XP SP1 users, please visit the Brother Solutions Center. (<a href="http://solutions.brother.com">http://solutions.brother.com</a>)</p>
The network PC-Fax Receive feature does not work.	
Your computer cannot find your machine.	<p>&lt;Windows® users&gt;</p> <p>Firewall settings on you PC may be rejecting the necessary network connection. For detail, see the instruction above.</p> <p>&lt;Macintosh® users&gt;</p> <p>Re-select your machine in the Device Selector application located in Macintosh HD/Library/Printers/Brother/Utilities/DeviceSelector or from the model list in ControlCenter2.</p>

## Dial Tone detection

When you send a fax automatically, by default your machine will wait for a fixed amount of time before it starts to dial the number. By changing the Dial Tone setting to `Detection` you can make your machine dial as soon as it detects a dial tone. This setting can save a small amount of time when sending a fax to many different numbers. If you change the setting and start having problems with dialling you should change back to the factory `No Detection` setting.

- 1 Press **Menu**.
- 2 Press **▲** or **▼** to choose `Initial Setup`. Press **OK**.
- 3 Press **▲** or **▼** to choose `Dial Tone`.
- 4 Press **◀** or **▶** to choose `Detection` or `No Detection`. Press **OK**.
- 5 Press **Stop/Exit**.

## Telephone line interference

If you are having problems sending or receiving a fax due to possible interference on the telephone line, you can change the compatibility setting, which reduces the modem speed to minimise errors.

- 1 Press **Menu**.
- 2 Press **▲** or **▼** to choose `Fax`. Press **OK**.
- 3 Press **▲** or **▼** to choose `Miscellaneous`. Press **OK**.
- 4 Press **▲** or **▼** to choose `Compatibility`.
- 5 Press **◀** or **▶** to choose `High`, `Normal` or `Basic (for VoIP)`.
  - `Basic (for VoIP)` cuts the modem speed to 9600 bps. Unless interference is a recurring problem on your telephone line, you may prefer to use it only when needed.
  - `Normal` sets the modem speed at 14400 bps.
  - `High` increases the modem speed to 33600 bps. (factory setting)
 Press **OK**.
- 6 Press **Stop/Exit**.



### Note

When you change the compatibility to `Basic (for VoIP)`, the ECM feature is only available for colour fax sending.

## Error and Maintenance messages

As with any sophisticated office product, errors may occur and consumable items may need to be replaced. If this happens, your machine identifies the error and shows an error message. The most common error and maintenance messages are shown below.

You can correct most errors and routine maintenance by yourself. If you need more help, the Brother Solutions Center offers the latest FAQs and troubleshooting tips.

Visit us at <http://solutions.brother.com>.

Error Message	Cause	Action
B&W Print Only	<p>One or more of the colour ink cartridges is empty.</p> <p>While this message appears on the LCD, each operation works in the following way:</p> <ul style="list-style-type: none"> <li>■ <b>Printing</b> <p>If you click <b>Greyscale</b> in the Advanced tab of the printer driver you can use the machine as a monochrome printer for approximately four weeks depending on the number of pages you print.</p> </li> <li>■ <b>Copying</b> <p>If the paper type is set to Plain Paper or Inkjet Paper you can make copies in monochrome.</p> </li> <li>■ <b>Faxing</b> <p>If the paper type is set to Plain Paper, Inkjet Paper or Transparency the machine will receive and print the faxes in monochrome.</p> <p>If a sending machine has a colour fax, the machine's 'handshake' will ask that the fax be sent as monochrome.</p> </li> </ul> <p>If the paper type is set to Other Glossy or Brother BP71, the machine will stop all print operations. If you unplug the machine, or take out the empty ink cartridge, you cannot use the machine until you change to a new ink cartridge.</p>	<p>Replace the empty ink cartridges. (See <i>Replacing the ink cartridges</i> on page 157.)</p>

Error Message	Cause	Action
BT Call Sign On (For U.K. only)	BT Call Sign is set to ON. You cannot change the Receive Mode from Manual to another mode.	Set BT Call Sign to OFF. (See <i>BT Call Sign (U.K. only)</i> on page 66.)
Cannot Detect	You installed a new ink cartridge too quickly and the machine did not detect it.	Take out the new ink cartridge and re-install it slowly until it clicks.
	If you are using non Brother Original ink the machine may not detect the ink cartridge.	Replace the cartridge with a Brother Original ink cartridge. If the error message remains, contact your Brother dealer.
	An ink cartridge is not installed correctly.	Take out the new ink cartridge and re-install it slowly until it clicks. (See <i>Replacing the ink cartridges</i> on page 157.)
Cannot Print	One or more of the ink cartridges are empty. The machine will stop all print operations. While memory is available, black and white faxes will be stored in the memory. If a sending machine has a colour fax, the machine's 'handshake' will ask that the fax be sent as monochrome.	Replace the empty ink cartridges. (See <i>Replacing the ink cartridges</i> on page 157.)
Comm.Error	Poor telephone line quality caused a communication error.	If the problem continues, call the telephone company and ask them to check your telephone line.
Connection Fail	You tried to poll a fax machine that is not in Polled Waiting mode.	Check the other fax machine's polling setup.
Cover is Open	The scanner cover is not closed completely.	Lift the scanner cover and then close it again.
	The ink cartridge cover is not completely closed.	Firmly close the ink cartridge cover until it clicks.
Data Remaining	Print data is left in the machine's memory.	Press <b>Stop/Exit</b> . The machine will cancel the job and clear it from the memory. Try to print again.
Disconnected	The other person or other person's fax machine stopped the call.	Try to send or receive again.
Document Jam	The document was not inserted or fed correctly, or the document scanned from the ADF was too long.	See <i>Using the ADF</i> on page 22. See <i>Document jam</i> on page 151.
High Temperature	The print head is too warm.	Allow the machine to cool down.
Hub is Unusable.	A Hub or USB Flash memory drive with Hub has been connected to the USB direct interface.	A Hub or USB Flash memory drive with Hub are not supported. Unplug the device from the USB direct interface.

Error Message	Cause	Action
Image Too Long.	The proportions of your photo are irregular so effects could not be added.	Choose a regularly proportioned image.
Image Too Small.	The size of your photo is too small to trim.	Choose a larger image.
Ink low	One or more of the ink cartridges are running out of ink. If a sending machine has a colour fax to send, your machine's 'handshake' will ask that the fax be sent as black and white. If the sending machine has the ability to convert it, the colour fax will be printed at your machine as a black and white fax.	Order a new ink cartridge. You can continue printing until the LCD shows <i>Cannot Print</i> . (See <i>Replacing the ink cartridges</i> on page 157.)
Low Temperature	The print head is too cold.	Allow the machine to warm up.
Media Error	The memory card is either corrupted, incorrectly formatted, or there is a problem with the memory card.	Put the card firmly into the slot again to make sure it is in the correct position. If the error remains, check the media drive (slot) of the machine by putting in another memory card that you know is working.
Media is Full.	The memory card or USB flash memory drive you are using already contains 999 files.	Your machine can only save to your memory card or USB flash memory drive if it contains less than 999 files. Try deleting unused files to free some space and try again.
No Caller ID	There is no incoming call history. You did not receive calls or you have not subscribed to the Caller ID service from your telephone company.	If you want to use the Caller ID feature call your telephone company. (See <i>Caller ID (U.K. and Ireland only)</i> on page 65.)
No Cartridge	An ink cartridge is not installed correctly.	Take out the new ink cartridge and re-install it slowly until it clicks. (See <i>Replacing the ink cartridges</i> on page 157.)
No File	The memory card or USB Flash memory drive in the media drive does not contain a .JPG file.	Put the correct memory card or USB Flash memory drive into the slot again.

Error Message	Cause	Action
No Paper Fed	The machine is out of paper or paper is not properly loaded in the paper tray.	Do one of the following: <ul style="list-style-type: none"> <li>■ Refill the paper in the paper tray, and then press <b>Mono Start</b> or <b>Colour Start</b>.</li> <li>■ Remove the paper and load it again and then press <b>Mono Start</b> or <b>Colour Start</b>.</li> </ul>
	The paper is jammed in the machine.	Remove the jammed paper by following the steps in <i>Printer jam or paper jam (MFC-5890CN only)</i> on page 152 or <i>Printer jam or paper jam (MFC-6490CW only)</i> on page 154.
	The jam clear cover (MFC-5890CN) or the outer rear cover or inner rear cover (MFC-6490CW) may not be closed properly.	(MFC-5890CN) Open the jam clear cover and then close it. Make sure the jam clear cover is closed properly.  (MFC-6490CW) Open the outer rear cover and inner rear cover. Then close the inner rear cover and outer rear cover. Make sure they are closed properly.
No Response/Busy	The number you dialled does not answer or is busy.	Verify the number and try again.
Not Registered	You tried to access a One Touch or Speed Dial number that is not programmed.	Set up the One Touch or Speed Dial number. (See <i>Storing Speed Dial numbers</i> on page 76.)
Out of Memory	The machine's memory is full.	<b>Fax sending or copy operation in progress</b> Do one of the following: <ul style="list-style-type: none"> <li>■ Press <b>Stop/Exit</b> and wait until the other operations in progress finish and then try again.</li> <li>■ Clear the data in the memory. To gain extra memory, you can turn off Memory Receive. (See <i>Memory Receive (Monochrome only)</i> on page 54.)</li> <li>■ Print the faxes that are in the memory. (See <i>Printing a fax from the memory</i> on page 54.)</li> </ul>
	The memory card or USB flash memory drive you are using does not have enough free space to scan the documents.	Delete unused files from your memory card or USB Flash memory drive to make some free space and then try again.

Error Message	Cause	Action
Paper Jam	Paper is jammed in the machine.	(MFC-6490CW) Open the Outer Rear Cover and Inner Rear Cover (at the back of the machine) and remove the jammed paper. (See <i>Printer jam or paper jam (MFC-6490CW only)</i> on page 154.)
		(MFC-5890CN) Open the Jam Clear Cover (at the back of the machine) and remove the jammed paper. (See <i>Printer jam or paper jam (MFC-5890CN only)</i> on page 152.)
		Make sure the paper length guide is adjusted to the correct paper size. Do not extend the paper tray when you load A5 or smaller size paper.
Unable to Clean XX	The machine has a mechanical problem.  —OR— A foreign object such as a clip or ripped paper is in the machine.	Open the scanner cover and remove any foreign objects inside the machine. If the error message continues, disconnect the machine from the power for several minutes, then reconnect it. (The machine can be turned off for approximately 24 hours without losing faxes stored in the memory. See <i>Transferring your faxes or Fax Journal report</i> on page 150.)
Unable to Init. XX	The machine has a mechanical problem.  —OR— A foreign object such as a clip or ripped paper is in the machine.	Open the scanner cover and remove any foreign objects inside the machine. If the error message continues, disconnect the machine from the power for several minutes, then reconnect it. (The machine can be turned off for approximately 24 hours without losing faxes stored in the memory. See <i>Transferring your faxes or Fax Journal report</i> on page 150.)
Unable to Print XX	The machine has a mechanical problem.  —OR— A foreign object such as a clip or ripped paper is in the machine.	Open the scanner cover and remove any foreign objects inside the machine. If the error message continues, disconnect the machine from the power for several minutes, then reconnect it. (The machine can be turned off for approximately 24 hours without losing faxes stored in the memory. See <i>Transferring your faxes or Fax Journal report</i> on page 150.)

Error Message	Cause	Action
Unable to Scan XX	<p>The machine has a mechanical problem.</p> <p>—OR—</p> <p>A foreign object such as a clip or ripped paper is in the machine.</p>	<p>Open the scanner cover and remove any foreign objects inside the machine. If the error message continues, disconnect the machine from the power for several minutes, then reconnect it. (The machine can be turned off for approximately 24 hours without losing faxes stored in the memory. See <i>Transferring your faxes or Fax Journal report</i> on page 150.)</p>
<p>Unusable Device</p> <p>Disconnect device from front connector &amp; turn machine off &amp; then on</p>	<p>A broken device has been connected to the USB direct interface.</p>	<p>Unplug the device from the USB direct interface, then press <b>Power Save</b> to turn the machine off and then on again.</p>
<p>Unusable Device</p> <p>Please Disconnect USB Device.</p>	<p>A USB device or USB Flash memory drive that is not supported has been connected to the USB direct interface.</p> <p>(For more information, visit us at <a href="http://solutions.brother.com">http://solutions.brother.com</a>.)</p>	<p>Unplug the device from the USB direct interface.</p>
Wrong Paper Size	<p>Paper is not the correct size.</p>	<p>(MFC-5890CN) Check that the machine's Paper Size setting matches the size of paper in the tray. (See <i>Paper Size</i> on page 27.)</p> <p>(MFC-6490CW) Make sure the machine's Paper Size setting matches the size of paper in the tray. (See <i>Paper Size and Type (MFC-6490CW only)</i> on page 27.) Also, check that the machine is set to use the tray with the paper size you want. (See <i>Tray use in Copy mode (MFC-6490CW only)</i> on page 28 and <i>Tray use in Fax mode (MFC-6490CW only)</i> on page 28.)</p>

## Error animations Display

Error animations display step-by-step instructions when paper gets jammed. You can read the steps at your own pace by pressing **▶** to see the next step and **◀** to go back. If you do not press a key after 1 minute the animation starts running automatically again.



### Note

You can press **◀**, **▶** or **OK** to pause the auto-animation and go back to step-by-step mode.

## Transferring your faxes or Fax Journal report

If the LCD shows:

- Unable to Clean XX
- Unable to Init. XX
- Unable to Print XX
- Unable to Scan XX

We recommend transferring your faxes to another fax machine or to your PC. (See *Transferring faxes to another fax machine* on page 150 or *Transferring faxes to your PC* on page 150.)

You can also transfer the Fax Journal report to see if there are any faxes you need to transfer. (See *Transferring Fax Journal report to another fax machine* on page 151.)



### Note

If there is an error message on the machine's LCD, after the faxes have been transferred, disconnect the machine from the power source for several minutes, and then reconnect it.

## Transferring faxes to another fax machine

If you have not set up your Station ID, you cannot enter fax transfer mode. (See *Enter personal information (station ID)* in the Quick Setup Guide.)

- 1 Press **Stop/Exit** to interrupt the error temporarily.
- 2 Press **Menu**.
- 3 Press **▲** or **▼** to choose *Service*. Press **OK**.
- 4 Press **▲** or **▼** to choose *Data Transfer*. Press **OK**.
- 5 Press **▲** or **▼** to choose *Fax Transfer*. Press **OK**.
- 6 Do one of the following:
  - If the LCD shows *No Data*, there are no faxes left in the machine's memory.  
Press **Stop/Exit**.
  - Enter the fax number to which faxes will be forwarded.
- 7 Press **Mono Start**.

## Transferring faxes to your PC

You can transfer the faxes from your machine's memory to your PC.

- 1 Press **Stop/Exit** to interrupt the error temporarily.
- 2 Make sure you have installed **MFL-Pro Suite** on your PC, and then turn on **PC FAX Receiving** on the PC. (For details see *PC- FAX receiving for Windows*<sup>®</sup> in the Software User's Guide on the CD-ROM.)

- 3 Make sure you have set PC Fax Receive on the machine. (See *PC Fax Receive* on page 56.)  
If faxes are in the machine's memory when you set up PC Fax Receive, the LCD will ask if you want to transfer the faxes to your PC.
- 4 Do one of the following:
  - To transfer all faxes to your PC, press **1**. You will be asked if you want a backup print.
  - To exit and leave the faxes in the memory, press **2**.
- 5 Press **Stop/Exit**.

### Transferring Fax Journal report to another fax machine

If you have not set up your Station ID, you cannot enter fax transfer mode. (See *Enter personal information (station ID)* in the Quick Setup Guide.)

- 1 Press **Stop/Exit** to interrupt the error temporarily.
- 2 Press **Menu**.
- 3 Press **▲** or **▼** to choose *Service*. Press **OK**.
- 4 Press **▲** or **▼** to choose *Data Transfer*. Press **OK**.
- 5 Press **▲** or **▼** to choose *Report Trans.* Press **OK**.
- 6 Enter the fax number to which Fax Journal report will be forwarded.
- 7 Press **Mono Start**.

## Document jam

Documents can jam in the ADF unit if they are not inserted or fed properly, or if they are too long. Follow the steps below to clear a document jam.

### Document is jammed in the top of the ADF unit

- 1 Take out any paper from the ADF that is not jammed.
- 2 Open the ADF cover.
- 3 Pull the jammed document out to the right.

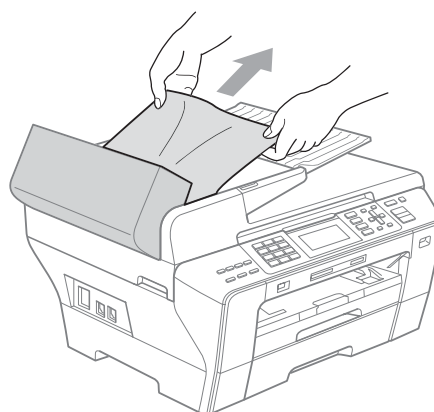

- 4 Close the ADF cover.
- 5 Press **Stop/Exit**.



#### Note

To avoid document jams close the ADF cover correctly by pushing it gently in the middle.

B

## Document is jammed inside the ADF unit

- 1 Take out any paper from the ADF that is not jammed.
- 2 Lift the document cover.
- 3 Pull the jammed document out to the right.

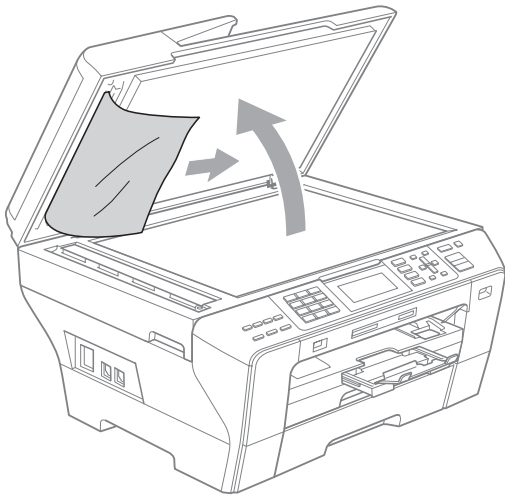

- 4 Close the document cover.
- 5 Press **Stop/Exit**.

## Printer jam or paper jam (MFC-5890CN only)

Take out the jammed paper depending on where it is jammed in the machine. Open and close the scanner cover to clear the error.

- 1 Pull the paper tray (1) out of the machine.

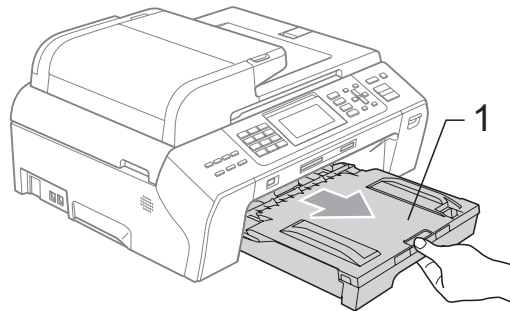

- 2 Pull out the jammed paper (1) and press **Stop/Exit**.

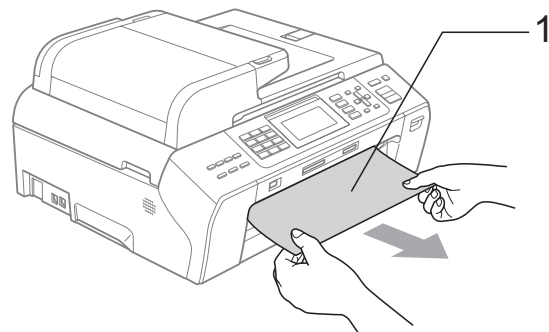

- 3 Reset the machine by lifting the scanner cover from the front of the machine and then close it.
  - If you cannot remove the jammed paper from the front side, or the error message still appears on the LCD after you remove the jammed paper, please go to the next step.

- 4 Open the Jam Clear Cover (1) from the back of the machine. Pull the jammed paper out of the machine.

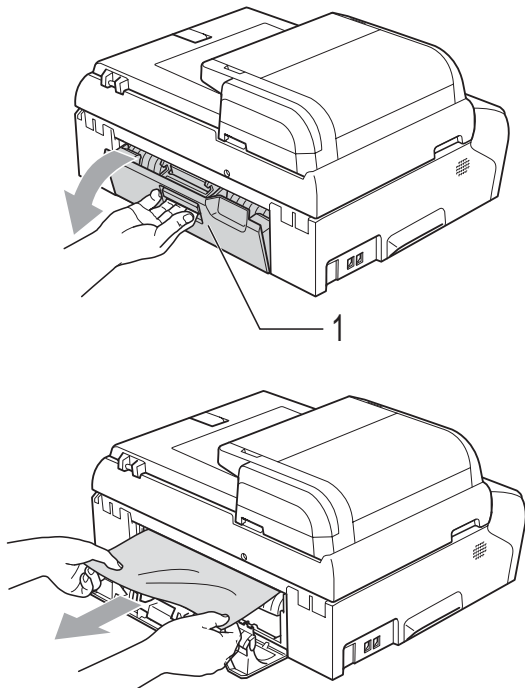

- 5 Close the Jam Clear Cover back on. Make sure the cover is set properly.

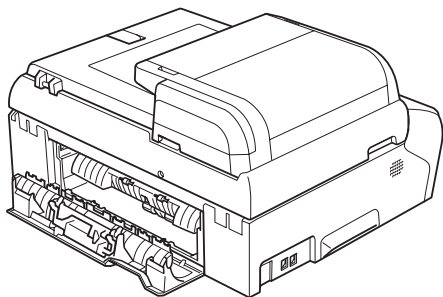

- 6 Using both hands, use the finger holds on both sides of the machine to lift the scanner cover (1) until it locks securely in the open position. Make sure that there is no jammed paper left inside the machine under the plastic covers. Check both ends of the print carriage.

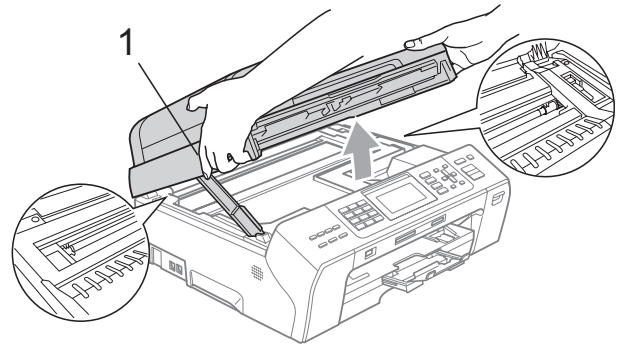

 **Note**

- If the paper is jammed under the print head, unplug the machine from the power source, and then move the print head to take out the paper.
- If the print head is at the right corner as shown in the illustration, you cannot move the print head. Hold down **Stop/Exit** until the print head moves to the middle. Then unplug the machine from the power source, and take out the paper.

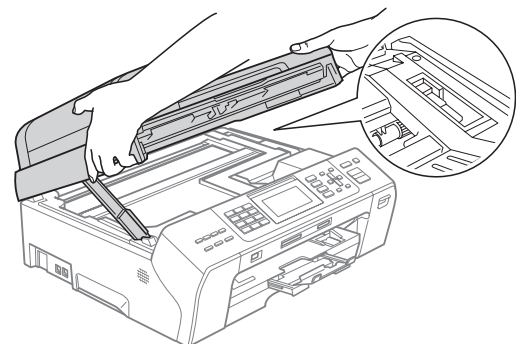

- If ink gets onto your skin, immediately wash with soap and plenty of water.

- 7 Lift the scanner cover to release the lock (1). Gently push the scanner cover support down (2) and close the scanner cover (3).

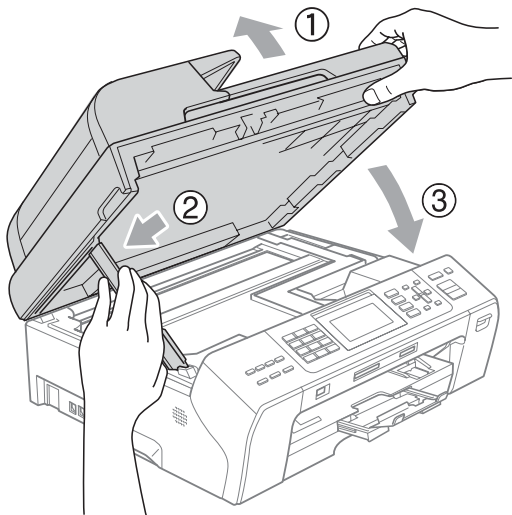

- 8 Push the paper tray firmly back into the machine.



**Note**

Make sure you pull out the paper support until it clicks.

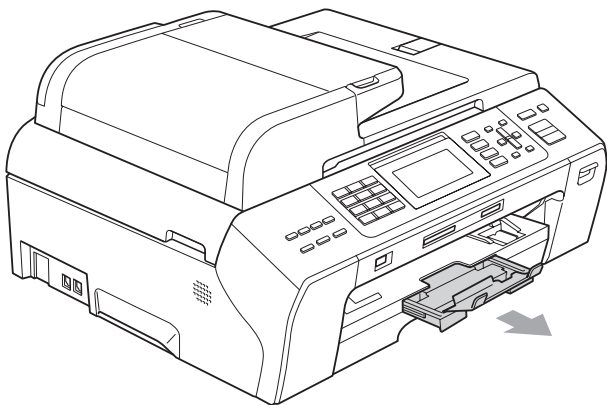

## Printer jam or paper jam (MFC-6490CW only)

Take out the jammed paper depending on where it is jammed in the machine. Open and close the scanner cover to clear the error.

- 1 Pull the paper tray (1) out of the machine.

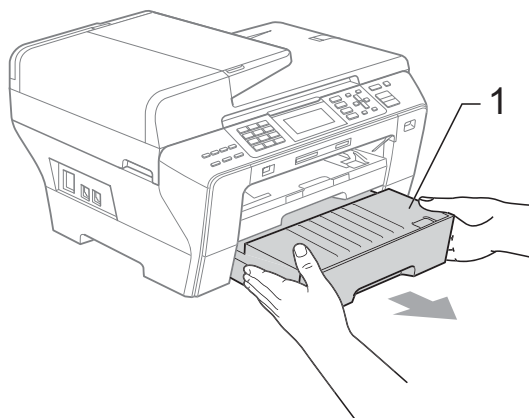
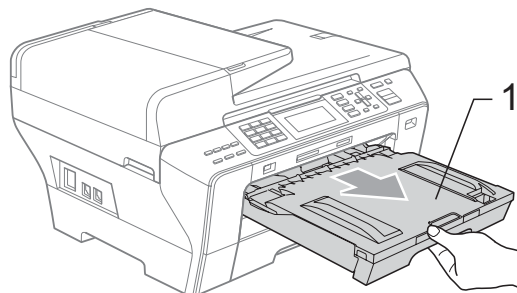

- 2 Pull out the jammed paper (1) and press **Stop/Exit**.

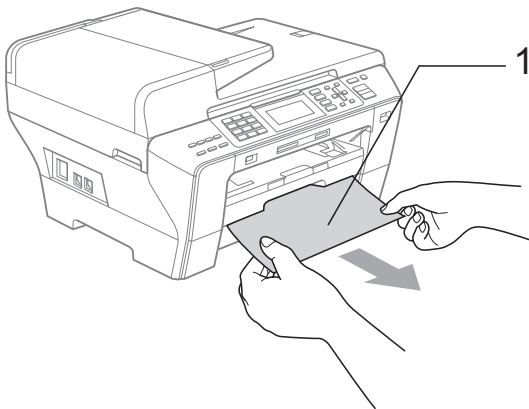
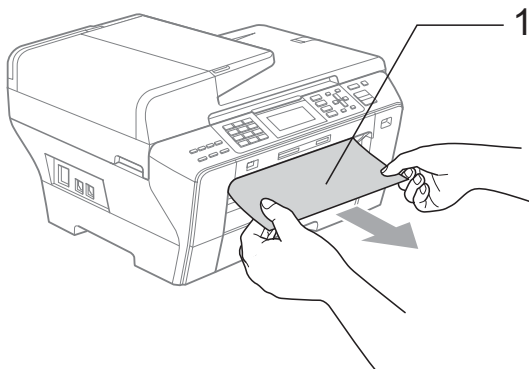

- 3 Reset the machine by lifting the scanner cover from the front of the machine and then close it.

- If you cannot remove the jammed paper from the front side, or the error message still appears on the LCD after you remove the jammed paper, please go to the next step.

- 4 Open the Outer Rear Cover (1) from the back of the machine. Pull the jammed paper out of the machine.

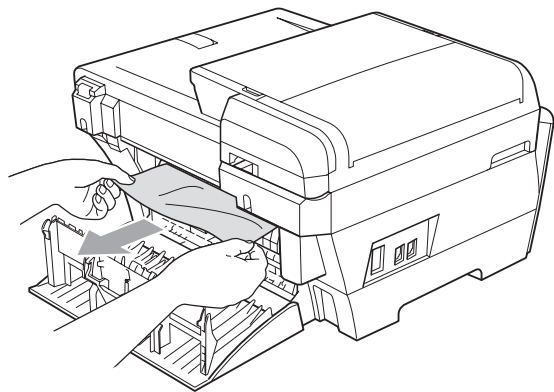
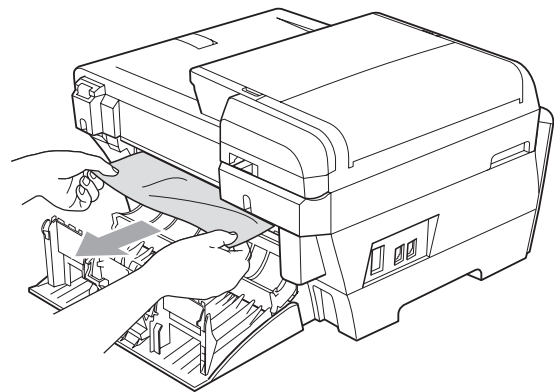
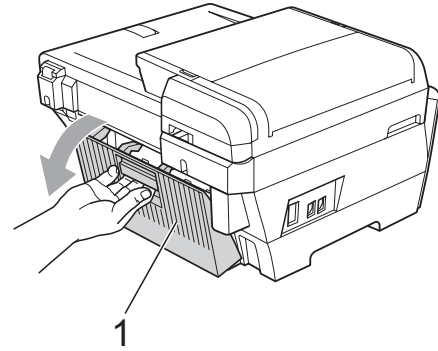

- 5 Close the Inner Rear Cover (1) if it is open like the illustration below.

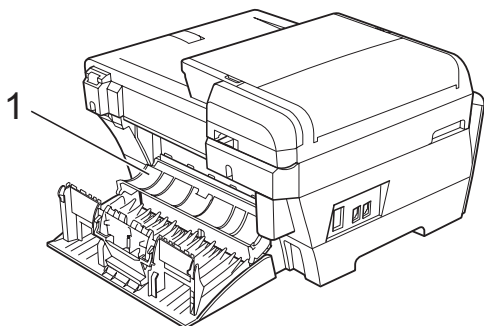

- 6 Close the Outer Rear Cover. Make sure the cover is closed correctly.

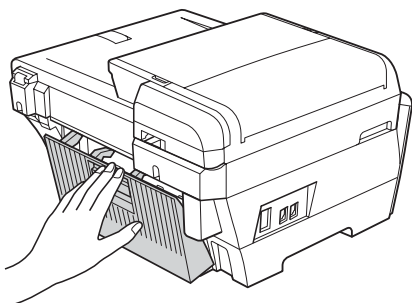

- 7 Using both hands, use the finger holds on both sides of the machine to lift the scanner cover (1) into the open position. Make sure that there is no jammed paper left in the corners of the machine.

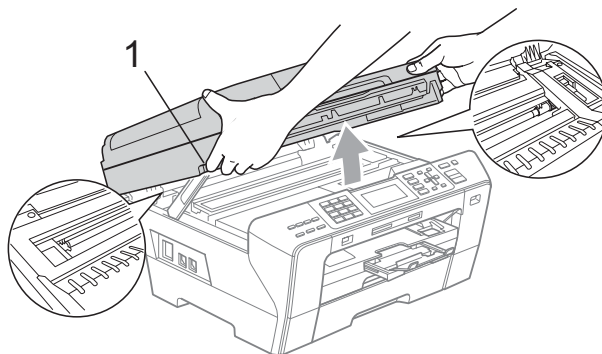

 **Note**

- If the paper is jammed under the print head, unplug the machine from the power source, and then move the print head to take out the paper.
- If the print head is at the right corner as shown in the illustration, you cannot move the print head. Hold down **Stop/Exit** until the print head moves to the middle. Then unplug the machine from the power source, and take out the paper.

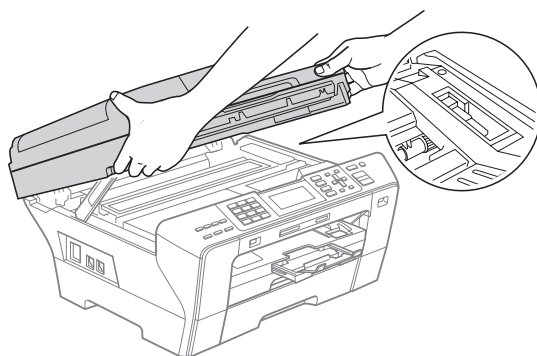

- If ink gets onto your skin, immediately wash with soap and plenty of water.

- 8 Gently close the scanner cover (1) using the finger holds on both sides of it.

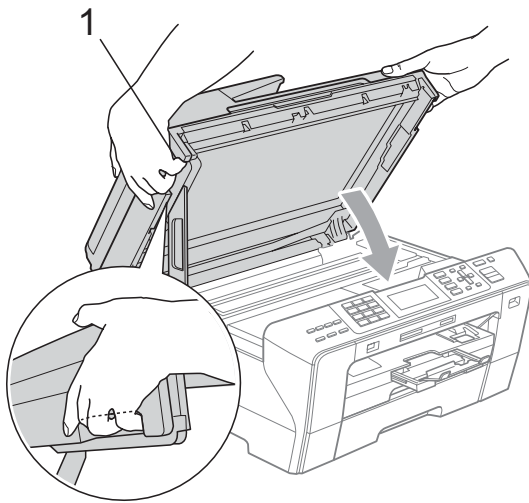

**! WARNING**

Be careful not to trap your fingers under the scanner cover.  
Always use the finger holds provided on both sides of the scanner cover when opening and closing it.

- 9 Push paper tray #1 and paper tray #2 firmly back into the machine.



**Note**

Make sure you pull out the paper support until it clicks.

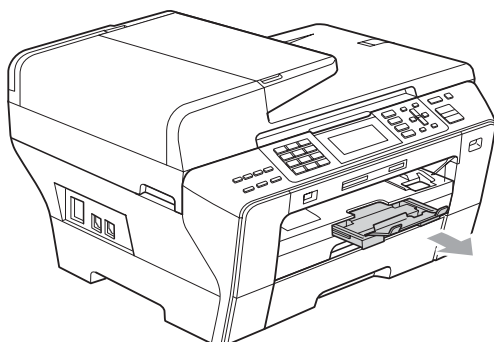

## Routine maintenance

### Replacing the ink cartridges

Your machine is equipped with an ink dot counter. The ink dot counter automatically monitors the level of ink in each of the 4 cartridges. When the machine detects an ink cartridge is running out of ink, the machine will tell you with a message on the LCD.

The LCD will tell you which ink cartridge is low or needs replacing. Be sure to follow the LCD prompts to replace the ink cartridges in the correct order.

Even though the machine tells you that an ink cartridge is empty, there will be a small amount of ink left in the ink cartridge. It is necessary to keep some ink in the ink cartridge to prevent air from drying out and damaging the print head assembly.

**! CAUTION**

Brother multifunction machines are designed to work with ink of a particular specification and will work to a level of optimum performance and reliability when used with genuine Brother Branded ink cartridges. Brother cannot guarantee this optimum performance and reliability if ink or ink cartridges of other specifications are used. Brother does not therefore recommend the use of cartridges other than genuine Brother Branded cartridges or the refilling of empty cartridges with ink from other sources. If damage is caused to the print head or other parts of this machine as a result of using other brands of ink or ink cartridges, any repairs required as a result may not be covered by the warranty.

**1** Open the ink cartridge cover. If one or more ink cartridges are empty, for example Black, the LCD shows `Cannot Print`.

**2** Press the lock release lever as shown to release the ink cartridge indicated on the LCD. Remove the cartridge from the machine.

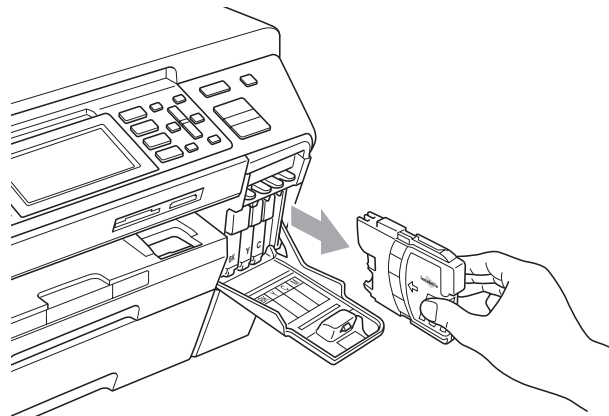
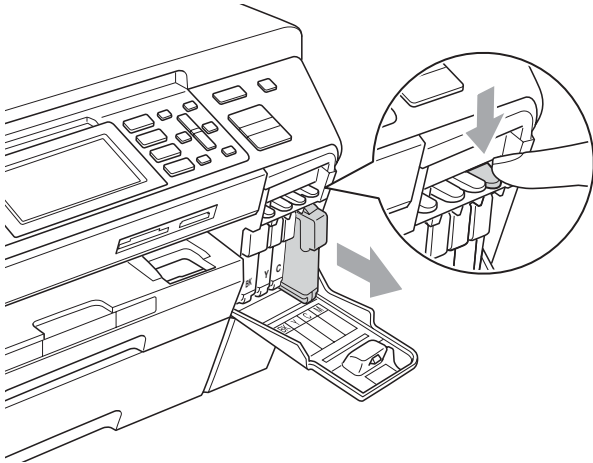

**3** Open the new ink cartridge bag for the colour shown on the LCD, and then take out the ink cartridge.

**4** Turn the green knob on the protective yellow cap clockwise until it clicks to release the vacuum seal, then remove the cap (1).

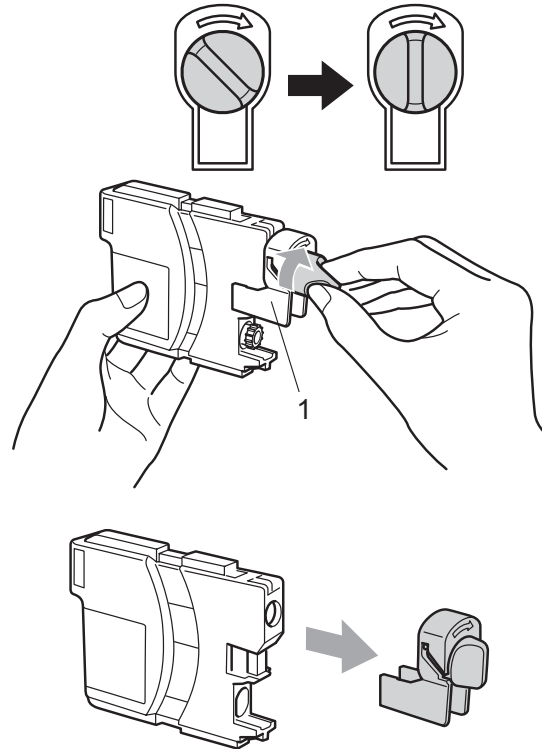

**5** Each colour has its own correct position. Insert the ink cartridge in the direction of the arrow on the label.

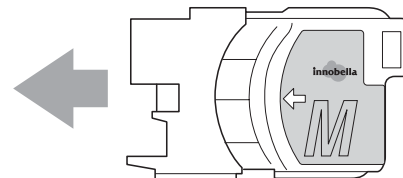

- 6 Gently push the ink cartridge until it clicks, and then close the ink cartridge cover.

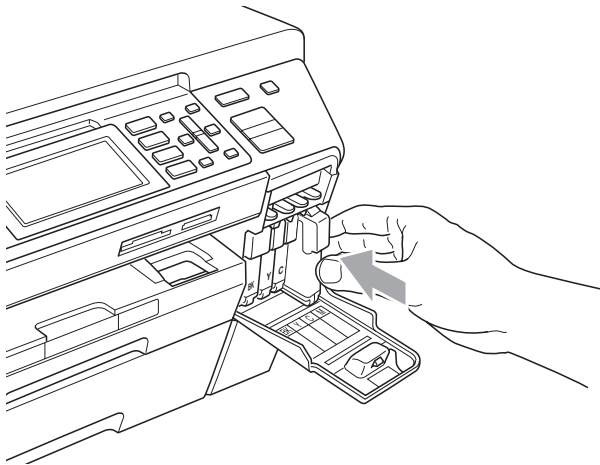

- 7 The machine will automatically reset the ink dot counter.

 **Note**

- If you replaced an ink cartridge, for example Black, the LCD may ask you to verify that it was a brand new one (for example, `Did You Change BK Black`). For each new cartridge you installed, press **1** (Yes) to automatically reset the ink dot counter for that colour. If the ink cartridge you installed is not a brand new one, be sure to press **2** (No).
- If the LCD shows `No Cartridge` or `Cannot Detect` after you install the ink cartridges, check that the ink cartridges are installed correctly.



**WARNING**

If ink gets in your eyes, wash them out with water at once and call a doctor if you are concerned.

 **CAUTION**

DO NOT take out ink cartridges if you do not need to replace them. If you do so, it may reduce the ink quantity and the machine will not know the quantity of ink left in the cartridge.

DO NOT touch the cartridge insertion slots. If you do so, the ink may stain your skin.

If ink gets on your skin or clothing immediately wash it off with soap or detergent.

If you mix the colours by installing an ink cartridge in the wrong position, clean the print head several times after correcting the cartridge installation.

Once you open an ink cartridge, install it in the machine and use it up within six months of installation. Use unopened ink cartridges by the expiration date written on the cartridge package.

DO NOT dismantle or tamper with the ink cartridge, this can cause the ink to leak out of the cartridge.

## Cleaning the outside of the machine

### ! CAUTION

Use neutral detergents. Cleaning with volatile liquids such as thinner or benzine will damage the outside surface of the machine.

DO NOT use cleaning materials that contain ammonia.

DO NOT use isopropyl alcohol to remove dirt from the control panel. It may crack the panel.

Clean the outside of the machine as follows:

- 1 Pull the paper trays (1) completely out of the machine.

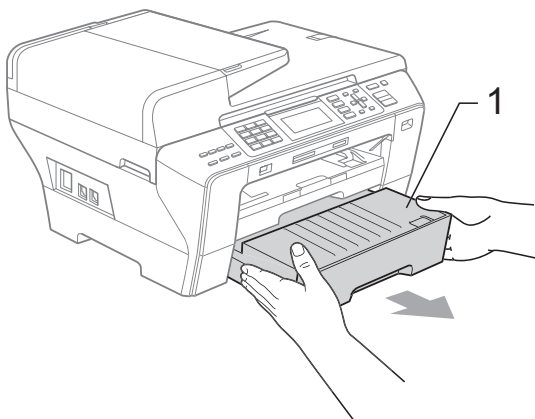
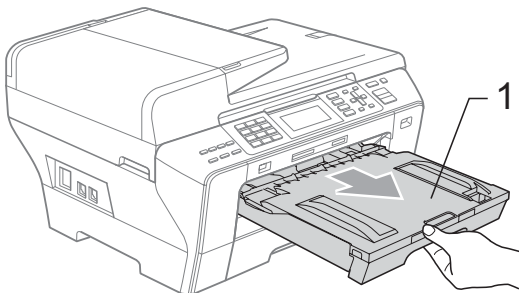

- 2 Wipe the outside of the machine with a soft cloth to remove dust.

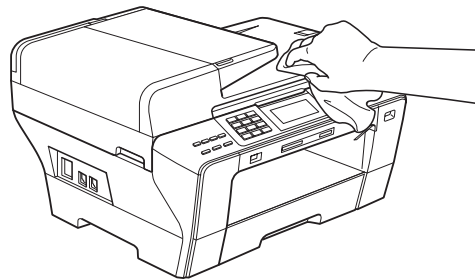

- 3 Remove anything that is stuck inside the paper tray.

- 4 Wipe the paper trays with a soft cloth to remove dust.

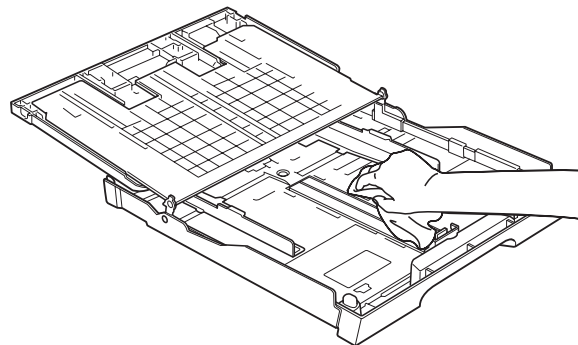

- 5 Put the paper trays firmly back in the machine.

## Cleaning the scanner glass

- 1 Lift the document cover (1). Clean the scanner glass (2) and the white plastic (3) with a soft lint-free cloth moistened with a non-flammable glass cleaner.

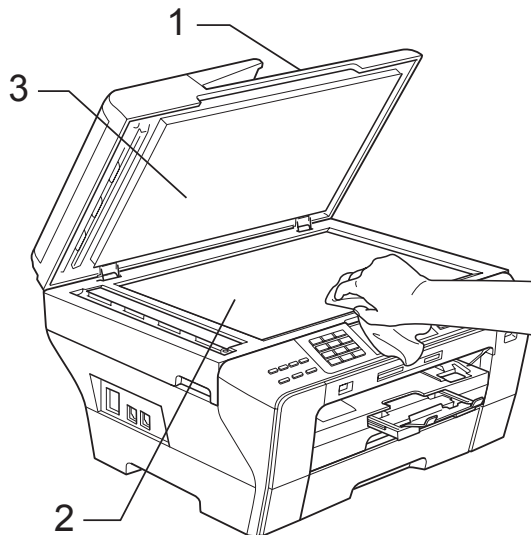

- 2 In the ADF unit, clean the white bar (1) and the glass strip (2) with a lint-free cloth moistened with a non-flammable glass cleaner.

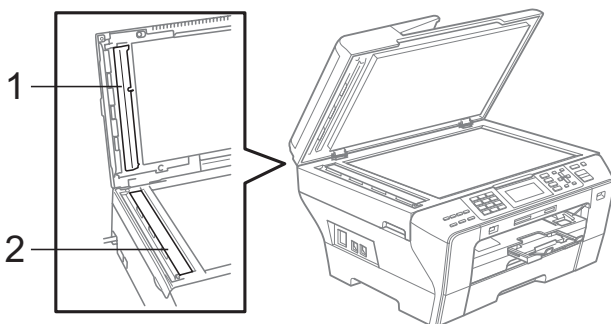

### Note

In addition to cleaning the glass strip with a non-flammable glass cleaner, run your finger tip over the glass strip to see if you can feel anything on it. If you feel dirt or debris, clean the glass strip again concentrating on that area. You may need to repeat the cleaning process three or four times. To test, make a copy after each cleaning attempt.

## Cleaning the machine printer platen

B

### WARNING

Be sure to unplug the machine from the electrical socket before cleaning the printer platen.

- 1 Using both hands, use the finger holds on both sides of the machine to lift the scanner cover until it locks securely into the open position.
- 2 Clean the machine's printer platen (1) and the area around it, wiping off any scattered ink with a soft, dry, lint-free cloth.

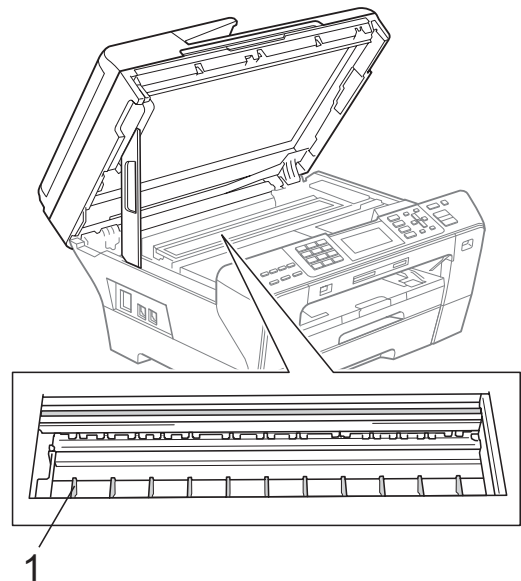

## Cleaning the paper pick-up roller

- 1 Pull the paper trays completely out of the machine.
- 2 (MFC-5890CN)  
Unplug the machine from the electrical socket and open the Jam Clear Cover (1) at the back of the machine.

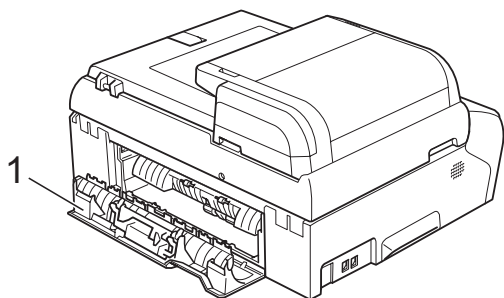

- (MFC-6490CW)  
Unplug the machine from the electrical socket and open the Outer Rear Cover (1) and Inner Rear Cover (2) from the back of the machine.

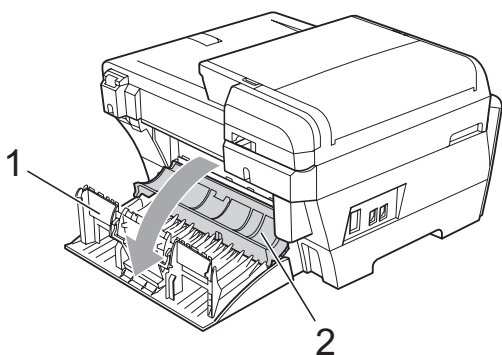

- 3 Clean the Paper Pick-up Roller (1) with isopropyl alcohol on a cotton swab.

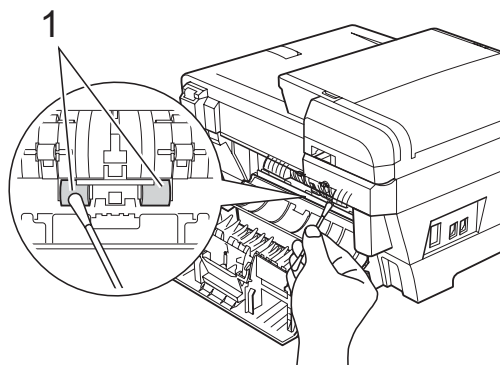

- 4 (MFC-5890CN)  
Close the Jam Clear Cover properly.  
  
(MFC-6490CW)  
Close the Inner Rear Cover and the Outer Rear Cover.  
Make sure the cover is closed correctly.
- 5 Put the paper trays firmly back in the machine.
- 6 Re-connect the power cord.

## Cleaning the print head

To maintain print quality, the machine will automatically clean the print head. You can start the cleaning process manually if there is a print quality problem.

Clean the print head and ink cartridges if you get a horizontal line or blank text in the text or graphics on your printed pages. You can clean Black only, three colours at a time (Cyan/Yellow/Magenta), or all four colours at once.

Cleaning the print head consumes ink.  
Cleaning too often uses ink unnecessarily.

### ! CAUTION

DO NOT touch the print head. Touching the print head may cause permanent damage and may void the print head's warranty.

- 1 Press **Ink Management**.
- 2 Press ▲ or ▼ to choose **Cleaning**. Press **OK**.
- 3 Press ▲ or ▼ to choose **Black, Color** or **All**. Press **OK**.  
The machine cleans the print head. When cleaning is finished, the machine will go back to standby mode automatically.



**Note**

If you clean the print head at least five times and the print has not improved, try installing a new genuine Brother Branded replacement cartridge for each problem colour. Try cleaning the print head again up to five more times. If the print has not improved call your Brother dealer.

## Checking the print quality

If faded or streaked colours and text appear on your output, some of the nozzles may be clogged. You can check this by printing the Print Quality Check Sheet and looking at the nozzle check pattern.

- 1 Press **Ink Management**.
- 2 Press ▲ or ▼ to choose **Test Print**. Press **OK**.
- 3 Press ▲ or ▼ to choose **Print Quality**. Press **OK**.
- 4 Press **Colour Start**.  
The machine begins printing the Print Quality Check Sheet.
- 5 Check the quality of the four colour blocks on the sheet.

- 6 The LCD asks you if the print quality is OK.  
Do one of the following:
  - If all lines are clear and visible, press **1 (Yes)** to finish the Print Quality check and go to step 10.
  - If you can see missing short lines as shown below, press **2** to choose **No**.

<Black>

OK



Poor



<Colour>

OK



Poor

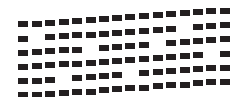

- 7 The LCD asks you if the print quality is OK for black and three colours.  
Press **1 (Yes)** or **2 (No)**.
- 8 The LCD asks you if you want to start cleaning.  
Press **1 (Yes)**.  
The machine starts cleaning the print head.
- 9 After cleaning is finished, press **Colour Start**.  
The machine starts printing the Print Quality Check Sheet again and then return to step 5.

- 10 Press **Stop/Exit**.  
If you repeat this procedure at least five times and the print quality is still poor, replace the ink cartridge for the clogged colour.  
After replacing the ink cartridge, check the print quality. If the problem still exists, repeat the cleaning and test print procedures at least five times for the new ink cartridge. If ink is still missing, call your Brother dealer.

### **CAUTION**

DO NOT touch the print head. Touching the print head may cause permanent damage and may void the print head's warranty.

### **Note**



When a print head nozzle is clogged the printed sample looks like this.



After the print head nozzle is cleaned, the horizontal lines are gone.

## Checking the print alignment

You may need to adjust the print alignment after transporting the machine, if your printed text becomes blurred or images become faded.

- 1 Press **Ink Management**.
- 2 Press **▲** or **▼** to choose `Test Print`. Press **OK**.
- 3 Press **▲** or **▼** to choose `Alignment`. Press **OK**.
- 4 Press **Mono Start** or **Colour Start**. The machine starts printing the Alignment Check Sheet.
- 5 Check the 600 dpi and 1200 dpi test prints to see if number 5 most closely matches number 0.
- 6 Do one of the following:
  - If the number 5 samples of both the 600 dpi and 1200 dpi test prints are the best matches, press **1** (`Yes`) to finish the Alignment Check and go to step 9.
  - If another test print number is a better match for either 600 dpi or 1200 dpi, press **2** (`No`) to choose it.
- 7 For 600 dpi, press the number of the test print that most closely matches the number 0 sample (1-8).
- 8 For 1200 dpi, press the number of the test print that most closely matches the number 0 sample (1-8).
- 9 Press **Stop/Exit**.

## Checking the ink volume

Although an ink volume icon appears on the LCD, you can use the **Ink Management** key to see a large graph showing the ink that is left in each cartridge.

- 1 Press **Ink Management**.
- 2 Press ▲ or ▼ to choose **Ink Volume**. Press **OK**.  
The LCD shows the ink volume.
- 3 Press **Stop/Exit**.



### Note

You can check the ink volume from your computer. (See *Printing for Windows*<sup>®</sup> or *Printing and Faxing for Macintosh*<sup>®</sup> in the Software User's Guide on the CD-ROM.)

## Machine Information

### Checking the serial number

You can see the machine's serial number on the LCD.

- 1 Press **Menu**.
- 2 Press ▲ or ▼ to choose **Machine Info**. Press **OK**.
- 3 Press ▲ or ▼ to choose **Serial No**. Press **OK**.
- 4 Press **Stop/Exit**.

## Packing and shipping the machine

When you transport the machine, use the packing materials that came with your machine. Follow the instructions below to properly pack your machine. Damage caused to your machine during transit is not covered by your warranty.



### CAUTION

It is important to allow the machine to 'park' the print head after a print job. Listen carefully to the machine before unplugging it to make sure that all mechanical noise has stopped. Not allowing the machine to finish this parking process may lead to print problems and possible damage to the print head.

- 1 Open the ink cartridge cover.
- 2 Press the lock release lever to release the ink cartridge and take out all the ink cartridges. (See *Replacing the ink cartridges* on page 157.)
- 3 Install the green protective part and then close the ink cartridge cover.

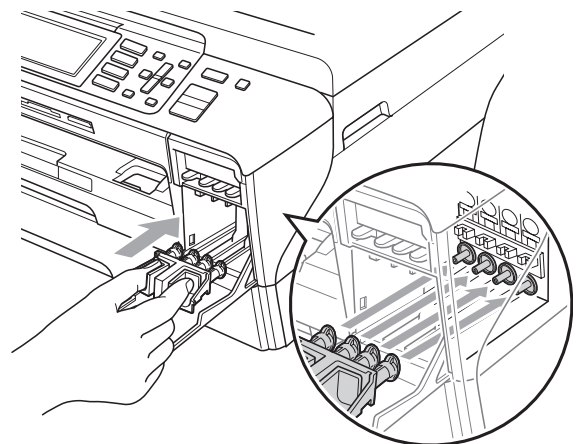

**! CAUTION**

Make sure that the plastic tabs on both sides of the green protective part (1) have securely clicked into place (2).

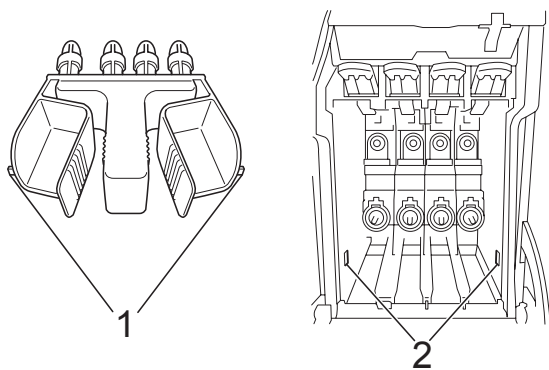

If you are not able to find the green protective part, DO NOT remove the ink cartridges before shipping. It is essential that the machine be shipped with either the green protective part or the ink cartridges in position. Shipping without them will cause damage to your machine and may void your warranty.

- 4 Unplug the machine from the telephone wall socket and take the telephone line cord out of the machine.
- 5 Unplug the machine from the electrical socket and from the machine.
- 6 (MFC-5890CN)  
Using both hands, use the finger holds on both sides of the machine to lift the scanner cover until it locks securely into the open position. Then unplug the interface cable from the machine, if it is connected.

(MFC-6490CW)

Using both hands, use the finger holds on both sides of the machine to lift the scanner cover into the open position. Then unplug the interface cable from the machine, if it is connected.

- 7 (MFC-5890CN)  
Lift the scanner cover (1) to release the lock. Gently push the scanner cover support down (2) and close the scanner cover (3).

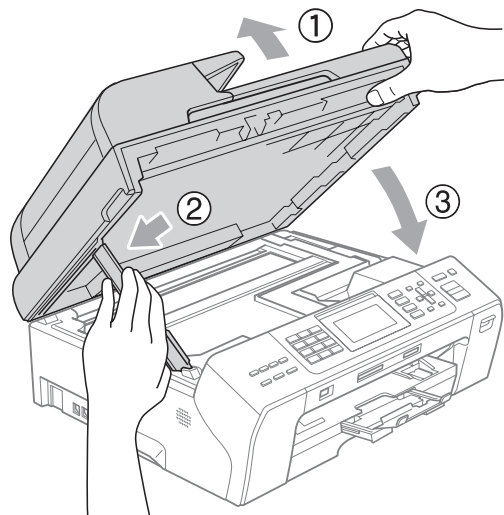

(MFC-6490CW)

Gently close the scanner cover using the finger holds on both sides of it as you push down on the Scanner Cover Support (1).

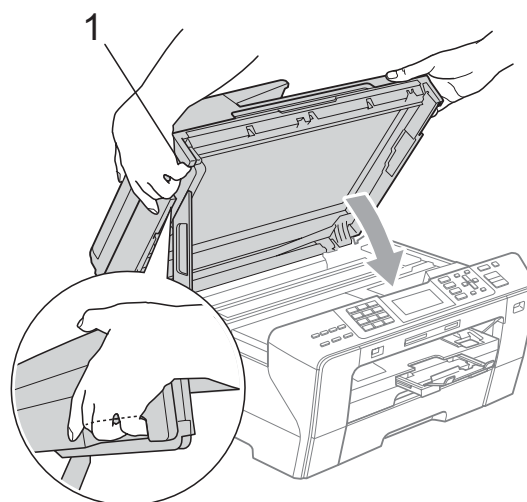

**! WARNING**

Be careful not to trap your fingers under the scanner cover.  
Always use the finger holds provided on both sides of the scanner cover when opening and closing it.

- 8 Wrap the machine in the bag.

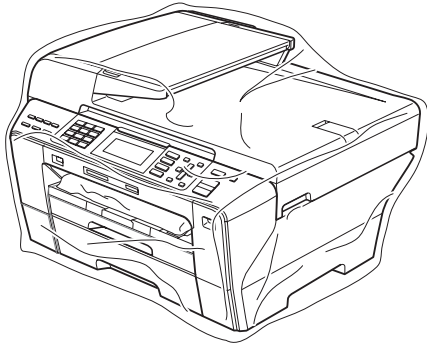

(MFC-6490CW)

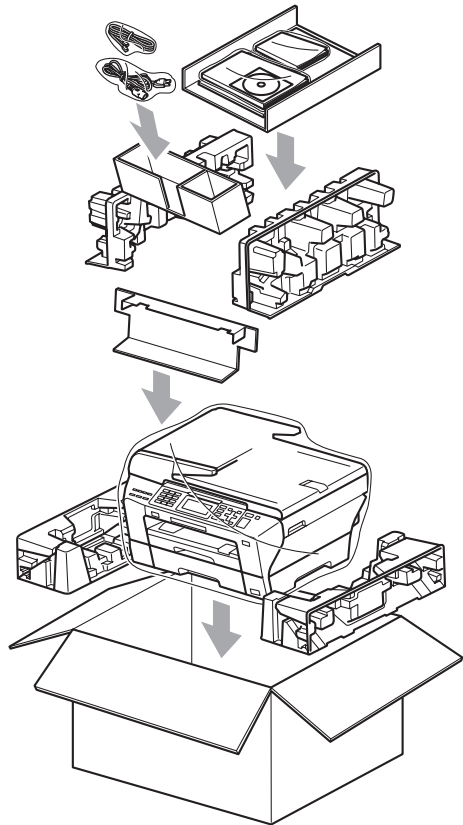

- 9 Pack the machine and the printed materials in the original carton with the original packing material as shown below. Do not pack the used ink cartridges in the carton.

(MFC-5890CN)

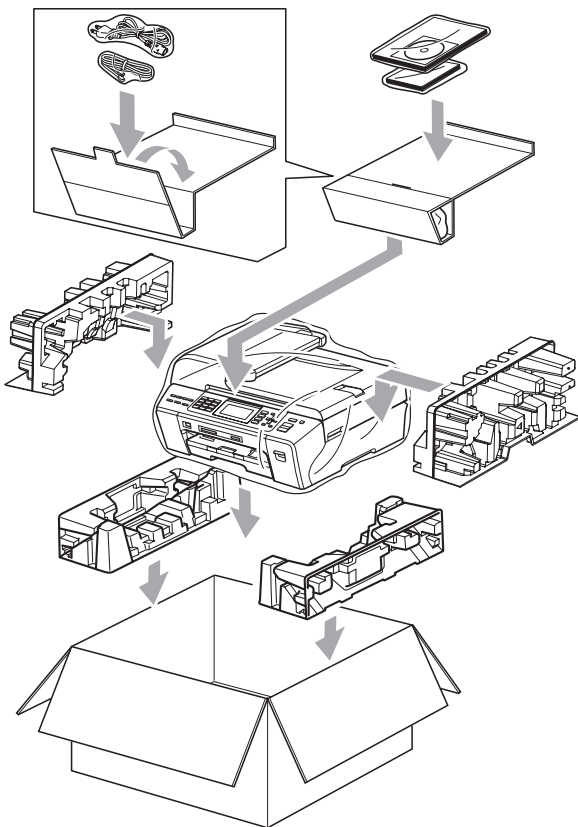

- 10 Close the carton and tape it shut.

## On-screen programming

Your machine is designed to be easy to operate with LCD on-screen programming using the menu keys. User-friendly programming helps you take full advantage of all the menu selections your machine has to offer.

Since your programming is done on the LCD, we have created step-by-step on-screen instructions to help you program your machine. All you need to do is follow the instructions as they guide you through the menu selections and programming options.

### Menu table

You can program your machine by using the Menu table that begins on page 169. These pages list the menu selections and options.













### Memory storage

Even if there is a power failure, you will not lose the settings you have chosen using the Menu key because they are stored permanently. Also, you will not lose your settings in the PhotoCapture, Fax and Copy mode key menus if you have chosen *Set New Default*. You may have to reset the date and time.

#### Note

During a power failure the machine will retain messages that are in the memory for approximately 24 hours.

## Mode and menu keys

	Access the main menu.
   	Press to access the temporary settings for each mode.
	Scroll through the current menu level.
	Scroll through the current menu level.
	Go back to the previous menu level.
	Go to the next menu level.
	<ul style="list-style-type: none"> <li>■ Go to the next menu level.</li> <li>■ Accept an option.</li> </ul>
	<ul style="list-style-type: none"> <li>■ Cancel the current operation.</li> <li>■ Go back to the previous menu level.</li> </ul>
	<ul style="list-style-type: none"> <li>■ Stop the current operation.</li> </ul>

## Menu table

The menu table will help you understand the menu selections and options that are found in the machine's programs. The factory settings are shown in Bold with an asterisk.

Menu ()

Level1	Level2	Level3	Options	Descriptions	Page
General Setup	Mode Timer	—	Off 0Sec 30Secs 1Min <b>2Mins*</b> 5Mins	Sets the time to return to Fax mode.	26
	Paper Type (MFC-5890CN)	—	<b>Plain Paper*</b> Inkjet Paper Brother BP71 Other Glossy Transparency	Sets the type of paper in the paper tray.	26
	Paper Size (MFC-5890CN)	—	<b>A4*</b> A5 A3 10x15cm Letter Legal Ledger	Sets the size of the paper in the paper tray.	27
 The factory settings are shown in Bold with an asterisk.					

Level1	Level2	Level3	Options	Descriptions	Page
General Setup (Continued)	Tray Setting (MFC-6490CW)	Tray#1	<b>Paper Type</b> (Options) <b>Plain Paper*</b> Inkjet Paper Brother BP71 Other Glossy Transparency	Sets the size and type of paper in paper tray #1.	27
			<b>Paper Size</b> (Options) <b>A4*</b> A5 A3 10x15cm Letter Legal Ledger		27
		Tray#2	<b>Paper Type</b> (Option) <b>Plain Paper</b>	Sets the size of the paper in the paper tray #2.	27
			<b>Paper Size</b> (Options) <b>A4*</b> A3 Letter Legal Ledger		



The factory settings are shown in Bold with an asterisk.

Level1	Level2	Level3	Options	Descriptions	Page	
General Setup (Continued)	Tray Setting (MFC-6490CW) (Continued)	Tray Use:Copy	Tray#1* Tray#2	Choose the tray that will be used for Copy mode.	28	
		Tray Use:Fax	Tray#1 Tray#2 <b>Auto Select*</b>	Choose the tray that will be used for Fax mode.	28	
	Volume	Ring	Off Low <b>Med*</b> High	Adjusts the ring volume.	29	
		Beeper	Off <b>Low*</b> Med High	Adjusts the volume level of the beeper.	30	
		Speaker	Off Low <b>Med*</b> High	Adjusts the speaker volume.	30	
	Auto Daylight	—	<b>On*</b> Off	Changes for Daylight Savings Time automatically.	30	
	P.Save Setting	—	<b>Fax Receive:On*</b> Fax Receive:Off	Customizes the <b>Power Save</b> key not to receive faxes in power save mode.	25	
	LCD Settings	LCD Contrast	Light <b>Med*</b> Dark	Adjusts the contrast of the LCD.	31	
		Backlight	<b>Light*</b> Med Dark	You can adjust the brightness of the LCD backlight.	31	
		Dim Timer	Off 10Secs 20Secs <b>30Secs*</b>	You can set how long the LCD backlight stays on for after the last key press.	32	
		Wallpaper	—	You can choose the wallpaper of the LCD.	32	
	 The factory settings are shown in Bold with an asterisk.					

Level1	Level2	Level3	Options	Descriptions	Page
General Setup (Continued)	Sleep Mode	—	1Min 2Mins 3Mins 5Mins <b>10Mins*</b> 30Mins 60Mins	You can choose how long the machine will remain idle before it goes into sleep mode.	31
	A3 - Short Grain	—	<b>On*</b> Off	Turn on this setting when you use A3 short grain paper.	29
	Function Lock	Set Password Lock Off-On Setup User Reset All Users	—	You can restrict selected machine operation for up to 20 restricted users and all other non-authorized Public users.	33
Fax	Setup Receive	Ring Delay	0 1 <b>2*</b> 3 4 5 6 7 8 (Example for the U.K.)	Sets the number of rings before the machine answers in Fax Only or Fax/Tel mode.	51
		F/T Ring Time	20Secs <b>30Secs*</b> 40Secs 70Secs	Sets the pseudo/double-ring time in Fax/Tel mode.	51
		Fax Detect	<b>On*</b> Off	Receives fax messages without pressing the <b>Mono Start</b> or <b>Colour Start</b> key.	52
		Remote Codes	<b>On*</b> (*51, #51) Off	Allows you to answer all calls at an extension or external telephone and use codes to turn the machine on or off. You can personalize these codes.	70
		Mono/Colour	<b>Mono (Max . A3) *</b> Colour (Max . A4)	Choose the receive options for incoming faxes.	53
		Auto Reduction	<b>On*</b> Off	Cuts the size of incoming faxes.	52



The factory settings are shown in Bold with an asterisk.

Level1	Level2	Level3	Options	Descriptions	Page	
Fax (Continued)	Setup Receive (Continued)	Memory Receive	<b>Off*</b> Fax Forward Fax Storage PC Fax Receive	You can set the machine to either forward fax messages, store incoming faxes in the memory (so you can retrieve them while you are away from your machine), or send faxes to your PC. If you choose Fax Forward or PC Fax Receive, you can turn on the safety feature Backup Print.	54	
		Report Setting	XMIT Report (MFC-5890CN)	On On+Image <b>Off*</b> Off+Image	Initial setup for Transmission Verification Report and Fax Journal Report.	82
			XMIT Report (MFC-6490CW)	On On+Image <b>Off*</b> Off+Image Off2 Off2+Image		
			Journal Period	Off <b>Every 50 Faxes*</b> Every 6 Hours Every 12 Hours Every 24 Hours Every 2 Days Every 7 Days		83
		Print Document	—	—	Prints incoming faxes stored in the memory.	54
		Remote Access	—	---*	Set your own code for Remote Retrieval.	60
		Remaining Jobs	—	—	Check which jobs are in the memory and lets you cancel chosen jobs.	47
		Miscellaneous	Compatibility	<b>High*</b> Normal Basic(for VoIP)	Adjusts the modem speed to help resolve transmission problems.	143
			BT Call Sign (U.K. Only)	On <b>Off*</b>	Uses with BT Call Sign.	66
			Caller ID (U.K. and Ireland only)	<b>On*</b> Off	View or print a list of the last 30 Caller IDs stored in the memory.	65
		 The factory settings are shown in Bold with an asterisk.				

## Network menu

Level1	Level2	Level3	Level4	Options	Descriptions
Network	Wired LAN	TCP/IP	BOOT Method	<b>Auto*</b> Static RARP BOOTP DHCP	Chooses the BOOT method that best suits your needs.
			IP Address	[000-255]. [000-255]. [000-255]. [000-255]	Enter the IP address.
			Subnet Mask	[000-255]. [000-255]. [000-255]. [000-255]	Enter the Subnet mask.
			Gateway	[000-255]. [000-255]. [000-255]. [000-255]	Enter the Gateway address.
			Node Name	BRNXXXXXXXXXXXXX	Enter the Node name.
			WINS Config	<b>Auto*</b> Static	Chooses the WINS configuration mode.
			WINS Server	(Primary) 000.000.000.000 (Secondary) 000.000.000.000	Specifies the IP address of the primary or secondary server.
			DNS Server	(Primary) 000.000.000.000 (Secondary) 000.000.000.000	Specifies the IP address of the primary or secondary server.
			APIPA	<b>On*</b> Off	Automatically allocates the IP address from the link-local address range.
See <i>Network User's Guide</i> on the CD-ROM					
 The factory settings are shown in Bold with an asterisk.					

Level1	Level2	Level3	Level4	Options	Descriptions
Network (Continued)	Wired LAN (Continued)	TCP/IP (Continued)	IPv6	On <b>Off*</b>	Enable or Disable the IPv6 protocol. If you want to use the IPv6 protocol, visit <a href="http://solutions.brother.com">http://solutions.brother.com</a> for more information.
		Ethernet	—	<b>Auto*</b> 100B-FD 100B-HD 10B-FD 10B-HD	Chooses the Ethernet link mode.
	WLAN (MFC-6490CW)	TCP/IP	BOOT Method	<b>Auto*</b> Static RARP BOOTP DHCP	Chooses the BOOT method that best suits your needs.
			IP Address	[000-255]. [000-255]. [000-255]. [000-255]	Enter the IP address.
			Subnet Mask	[000-255]. [000-255]. [000-255]. [000-255]	Enter the Subnet mask.
			Gateway	[000-255]. [000-255]. [000-255]. [000-255]	Enter the Gateway address.
			Node Name	BRWXXXXXXXXXXXX	Enter the Node name.
			WINS Config	<b>Auto*</b> Static	Chooses the WINS configuration mode.
			WINS Server	(Primary) 000.000.000.000 (Secondary) 000.000.000.000	Specifies the IP address of the primary or secondary server.
			See Network User's Guide on the CD-ROM		
	The factory settings are shown in Bold with an asterisk.				

Level1	Level2	Level3	Level4	Options	Descriptions
Network (Continued)	WLAN (MFC-6490CW) (Continued)	TCP/IP (Continued)	DNS Server	(Primary) 000.000.000.000  (Secondary) 000.000.000.000	Specifies the IP address of the primary or secondary server.
			APIPA	On*  Off	Automatically allocates the IP address from the link-local address range.
			IPv6	On  Off*	Sets the IPv6 protocol On.
		Setup Wizard	—	—	You can configure your print server.
		SES/WPS/AOSS	—	—	You can easily configure your wireless network settings using the one-button push method.
		WPS w/PIN Code	—	—	You can easily configure your wireless network settings using WPS with a PIN code.
		WLAN Status	Status	—	You can see the current wireless network status.
			Signal	—	You can see the current wireless network signal strength.
			SSID	—	You can see the current SSID.
			Comm. Mode	—	You can see the current Communication Mode.

See *Network User's Guide on the CD-ROM*



The factory settings are shown in Bold with an asterisk.

Level1	Level2	Level3	Level4	Options	Descriptions	
Network (Continued)	E-mail/IFAX (MFC-6490CW)  (Available as a download for MFC-5890CN)	Mail Address	Mail Address	—	Enter the mail address. (Up to 60 characters)	
		Setup Server	SMTP Server	Name (Up to 30 characters)	Name (Up to 30 characters)  IP Address [000-255]. [000-255]. [000-255]. [000-255]	Enter the SMTP server address.
				IP Address [000-255]. [000-255]. [000-255]. [000-255]		
				SMTP Port		
			Auth. for SMTP	None SMTP-AUTH POP bef. SMTP	Selects the Security method for E-mail notification	
			POP3 Server	Name (Up to 30 characters)	Name (Up to 30 characters)  IP Address [000-255]. [000-255]. [000-255]. [000-255]	Enter the POP3 server address.
				IP Address [000-255]. [000-255]. [000-255]. [000-255]		
			POP3 Port	[00001-65535]	Enter the POP3 port number.	
			Mailbox Name	—	Enter the mail box name. (Up to 20 characters)	
			Mailbox Pwd	—	Enter the password to login to the POP3 server. (Up to 20 characters)	
			APOP	On <b>Off*</b>	Enables or disables APOP.	
		Setup Mail RX	Auto Polling	<b>On*</b> Off	Automatically checks the POP3 server for new messages.	
			Poll Frequency	10Min (s)	Sets the interval for checking for new messages on the POP3 server.	
			Header	All Subject+From+To <b>None*</b>	Selects the contents of the mail header to be printed.	
See <i>Network User's Guide on the CD-ROM</i>						
 The factory settings are shown in Bold with an asterisk.						

Level1	Level2	Level3	Level4	Options	Descriptions	
Network (Continued)	E-mail/IFAX (MFC-6490CW)  (Available as a download for MFC-5890CN)  (Continued)	Setup Mail RX (Continued)	Del Error Mail	On* Off	Deletes error mails automatically.	
			Notification	On MDN Off*	Receives notification messages.	
			Setup Mail TX	Sender Subject	—	Displays the subject that is attached to the Internet Fax data.
				Size Limit	On Off*	Limits the size of E-mail documents.
				Notification	On Off*	Sends notification messages.
		Setup Relay	Rly Broadcast	On Off*	Relays a document to another fax machine over the internet.	
			Relay Domain	—	Registers the Domain name.	
			Relay Report	On Off*	Prints the Relay Broadcast Report.	
		Scan to FTP	Passive Mode	Off On*	—	You can set Passive Mode to OFF or ON depending on your FTP server and network firewall configuration.
			Port Number	—	—	You can change the port number used to access the FTP server.
			File Name1	—	—	In addition to the seven preset file names, you can store two user defined file names that can be used for creating an FTP Server Profile.
			File Name2	—	—	
			Setup Profile	Not Registered	—	You can setup your FTP Profile.

See *Network User's Guide on the CD-ROM*



The factory settings are shown in Bold with an asterisk.

Level1	Level2	Level3	Level4	Options	Descriptions
<b>Network</b> (Continued)	<b>Time Zone</b> (MFC-6490CW)  (Available as a download for MFC-5890CN)	—	UTC+XX:XX	—	Sets the time zone for your country.
	<b>Network I/F</b> (MFC-6490CW)	—	<b>Wired LAN*</b>  WLAN	—	You can choose the network connection type.
	<b>Factory Reset</b>	—	—	Yes No	Restores all wired and wireless network settings to the factory default.
<i>See Network User's Guide on the CD-ROM</i>					
 The factory settings are shown in Bold with an asterisk.					

Menu (  ) (continued)

Level1	Level2	Level3	Options	Descriptions	Page
Print Reports	XMIT Verify	—	—	Prints these lists and reports.	83
	Help List	—	—		
	Quick Dial	—	Alphabetical Order Numerical Order		
	Fax Journal	—	—		
	User Settings	—	—		
	Network Config	—	—		
	Caller ID hist.	—	—		
Machine Info.	Serial No.	—	—	Lets you check the serial number of your machine.	165
Initial Setup	Receive Mode	—	<b>Fax Only*</b> Fax/Tel External TAD Manual	Choose the receive mode that best suits your needs.	49
	Date&Time	—	—	Puts the date and time on the LCD and in headings of faxes you send.	See <i>Quick Setup Guide</i>
	Station ID	—	Fax: Name:	Set your name and fax number to appear on each page you fax.	
	Tone/Pulse	—	<b>Tone*</b> Pulse	Choose the dialling mode.	
	Dial Tone	—	Detection <b>No Detection*</b>	Turns Dial Tone Detection on or off.	143
	Phone Line Set	—	<b>Normal*</b> PBX ISDN	Choose the telephone line type.	66
 The factory settings are shown in Bold with an asterisk.					

Fax (  )

Level1	Level2	Level3	Options	Descriptions	Page
Fax Resolution	—	—	<b>Standard*</b> Fine S.Fine Photo	Sets the resolution for outgoing faxes.	45
Contrast	—	—	<b>Auto*</b> Light Dark	Changes the lightness or darkness of faxes you send.	45
Glass ScanSize (MFC-6490CW)	—	—	<b>A4*</b> A3 Letter Legal Ledger	Sets the glass scan size to Fax.	42
Phone Book	Search	—	Alphabetical Order Numerical Order	You can dial by pressing only a few keys (and <b>Start</b> ).	73
	Set One Touch Dial	—	—	Stores One Touch numbers, so you can dial by pressing only a few keys (and <b>Start</b> ).	74
	Set Speed Dial	—	—	Stores Speed Dial numbers, so you can dial by pressing only a few keys (and <b>Start</b> ).	76
	Setup Groups	—	—	Sets up a Group number for Broadcasting.	79
Outgoing Call	Send a fax Add To Phone Book Delete	—	—	You can choose a number from the Outgoing Call history and then make a telephone call to it, send a fax to it, add it to Speed Dial, or delete it.	73
Caller ID hist. (For U.K. and Ireland only)	Send a fax Add To Phone Book Delete	—	—	You can choose a number from the Caller ID history and then send a fax to it, add it to Speed Dial, or delete it.	74
Broadcasting	Add Number Phone Book Complete	—	—	You can send the same fax message to more than one fax number.	43
Delayed Fax	—	—	On (00:00) <b>Off*</b>	Sets the time of day in 24-hour format that the delayed faxes will be sent.	46
 The factory settings are shown in Bold with an asterisk.					

Level1	Level2	Level3	Options	Descriptions	Page
Batch TX	—	—	On <b>Off*</b>	Combines delayed faxes to the same fax number at the same time of day into one transmission.	47
Real Time TX	—	—	On <b>Off*</b>	You can send a fax without using the memory.	46
Polled TX	—	—	Standard Secure <b>Off*</b>	Sets up the document on your machine to be retrieved by another fax machine.	86
Polling RX	—	—	Standard Secure Timer <b>Off*</b>	Sets up your machine to poll another fax machine.	84
Overseas Mode	—	—	On <b>Off*</b>	If you are having difficulty sending faxes overseas, set this to On.	46
Glass ScanSize (MFC-5890CN)	—	—	<b>A4*</b> Letter	Adjust the scan area of the scanner glass to the size of the document.	41
Set New Default	—	—	Yes No	You can save your fax settings.	47
Factory Reset	—	—	Yes No	You can restore all settings to the factory settings.	47
 The factory settings are shown in Bold with an asterisk.					

Scan (  )

Level1	Option1	Option2	Option3	Descriptions	Page	
Scan to E-mail	PC	—	—	You can scan a monochrome or a colour document into your E-mail application.	See <i>Software User's Guide on the CD-ROM</i>	
	<b>E-mail Server</b> (MFC-6490CW)  (Available as a download for MFC-5890CN)	<b>Phone Book</b>		Alphabetical Order Numerical Order		You can search E-mail addresses you have stored in your machine.
		<b>Quality</b>		<b>Color 150 dpi*</b> Color 300 dpi Color 600 dpi B/W 200x100 dpi B/W 200 dpi		Chooses the file format to send the scanned data via E-mail server.
		<b>File Type</b>		(If you chose colour option in Quality setting) <b>PDF*</b> JPEG		
				(If you chose Mono option in Quality setting) <b>PDF*</b> TIFF		
		<b>Glass ScanSize</b> (MFC-6490CW)		<b>A4*</b> A3 Letter Legal Ledger		Sets the glass scan size to Scan.
		<b>Set New Default</b>		Yes No		You can save your scan settings.
		<b>Factory Reset</b>		Yes No		You can restore all settings to the factory settings.
Scan to Image	—	—	—	You can scan a colour picture into your graphics application.		
Scan to OCR	—	—	—	You can have your text document converted to an editable text file.		
 The factory settings are shown in Bold with an asterisk.						

Level1	Option1	Option2	Option3	Descriptions	Page
Scan to File	—	—	—	You can scan a monochrome or a colour document into your computer.	See <i>Software User's Guide on the CD-ROM</i>
Scan to Media (when a memory card or USB Flash memory drive is inserted)	<b>Quality</b>	—	Color 150 dpi* Color 300 dpi Color 600 dpi B/W 200x100 dpi B/W 200 dpi	You can choose the scan resolution, file format and enter a file name for your document.	114
	<b>File Type</b>	—	(If you chose colour option in Quality setting) <b>PDF*</b> JPEG		
			(If you chose Mono option in Quality setting) <b>PDF*</b> TIFF		
	<b>Glass ScanSize</b> (MFC-6490CW)	—	<b>A4*</b> A3 Letter Legal Ledger	Sets the glass scan size to Scan.	116
	<b>File Name</b>	—	—	You can rename the file.	116
	<b>Set New Default</b>	—	Yes No	You can save your scan settings.	116
	<b>Factory Reset</b>	—	Yes No	You can restore all settings to the factory settings.	116
 The factory settings are shown in Bold with an asterisk.					

Level1	Option1	Option2	Option3	Descriptions	Page
Scan to FTP	(Profile Name)	—	—	Enter the name that you want to use for the profile of the FTP server. This name will be displayed on the LCD screen.	See <i>Software User's Guide on the CD-ROM</i>
	Manual	Quality	Color 150 dpi* Color 300 dpi Color 600 dpi B/W 200x100 dpi B/W 200 dpi	Chooses the file format to send the scanned data via Media.	
		File Type	(If you chose colour option in Quality setting) <b>PDF*</b> JPEG		
			(If you chose Mono option in Quality setting) <b>PDF*</b> TIFF		
		Glass ScanSize (MFC-6490CW)	<b>A4*</b> A3 Letter Legal Ledger	Sets the glass scan size to Scan.	
		File Name	—	You can rename the file.	
		Set New Default	Yes No	You can save your scan settings.	
Factory Reset	Yes No	You can restore all settings to the factory settings.			











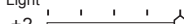

The factory settings are shown in Bold with an asterisk.

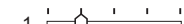
## Copy ( )

Level1	Level2	Level3	Options	Descriptions	Page
Quality	—	—	Fast <b>Normal*</b> Best	Choose the Copy resolution for your type of document.	89
Enlarge/Reduce	100%*	—	—	—	89
	Enlarge	—	198% 10x15cm→A4 186%10x15cm→LTR 142% A4→A3, A5→A4	You can choose the enlargement ratio for your type of document.	89
	Reduce	—	97% LTR→A4 93% A4→LTR 83% LGL→A4 69% A3→A4 <b>(MFC-6490CW),</b> A4→A5 47% A4→10x15cm	You can choose the reduction ratio for your type of document.	89
	Fit to Page	—	—	Your machine will adjust the size automatically to the paper size you set.	89
	Custom(25-400%)	—	—	You can choose the enlargement or reduction ratio for your type of document.	89
Tray Select (MFC-6490CW)	—	—	<b>Tray#1*</b> Tray#2	Choose the tray that will be used for Copy mode.	93
Paper Type	—	—	<b>Plain Paper*</b> Inkjet Paper Brother BP71 Other Glossy Transparency	Choose the paper type that matches the paper in the tray.	93
Paper Size	—	—	<b>A4*</b> A5 A3 10x15cm Letter Legal Ledger	Choose the paper size that matches the paper in the tray.	93



The factory settings are shown in Bold with an asterisk.

Level1	Level2	Level3	Options	Descriptions	Page
<b>Brightness</b>	—	—	Light +2  +1  0  -1  -2  Dark	Adjusts the brightness of copies.	92
<b>Contrast</b>	—	—	+2  +1  0  -1  -2 	Adjusts the contrast of copies.	93
<b>Stack/Sort</b>	—	—	<b>Stack*</b> Sort	You can choose to stack or sort multiple copies.	92
<b>Page Layout</b>	—	<b>Off (1 in 1)*</b> 2 in 1 (P) 2 in 1 (L) 4 in 1 (P) 4 in 1 (L) 1 to 2 (MFC-6490CW) Poster (2 x 2) Poster (3 x 3)	<b>(MFC-6490CW)</b> <b>If you choose A3 or Ledger.</b> <b>(When 2 in 1 is chosen)</b> LGRx2 → LGRx1 LTRx2 → LGRx1 A3x2 → A3x1 A4x2 → A3x1 <b>(When Poster(2x2) is chosen)</b> LGRx1 → LGRx4 LTRx1 → LGRx4 A4x1 → A3x4 A3x1 → A3x4	You can make N in 1, 1 to 2 or Poster copies.	90
<b>Skew Adjustment</b> (MFC-6490CW)	—	—	<b>Auto*</b> Off	If your scanned copy is skewed, your machine can correct the data automatically.	94
<b>Book Copy</b>	On	—	—	Corrects dark borders and skew when copying from the scanner glass.	94
	On (Preview)	<b>Skew Adjustment</b>	—		
		<b>Shadow Revise</b>	—		
<b>Off*</b>	—	—			
 The factory settings are shown in Bold with an asterisk.					

Level1	Level2	Level3	Options	Descriptions	Page
Watermark Copy	Watermark Copy	On <b>Off*</b>	(If you choose On, see the watermark copy settings in the following table.)	You can place a logo or text into your document as a Watermark.	95
	Current Setting	—			
	Exit	—			
Set New Default	—	—	Yes No	You can save your copy settings.	96
<b>Factory Reset</b>	—	—	Yes No	You can restore all settings to the factory settings.	96
 The factory settings are shown in Bold with an asterisk.					

## Watermark Copy Settings

Option1	Option2	Option3	Option4	Descriptions	Page
Template	—	<b>Text</b>	<b>CONFIDENTIAL*</b> DRAFT COPY	Places a text into your document as a Watermark using a template.	95
		<b>Position</b>	A B C D <b>E*</b> F G H I Pattern		
		<b>Size</b>	Small <b>Medium*</b> Large		
		<b>Angle</b>	-90° <b>-45°*</b> 0° 45° 90°		
		<b>Transparency</b>	-2 -1 <b>0*</b> +1 +2		
		<b>Colour</b>	Red Orange Yellow Blue Green Purple <b>Black*</b>		
		<b>Apply</b>	—		
		 The factory settings are shown in Bold with an asterisk.			













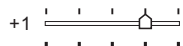
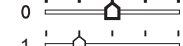

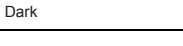
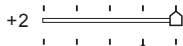

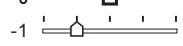
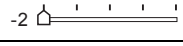

Option1	Option2	Option3	Option4	Descriptions	Page
<b>Media</b>	(Select image from media)	<b>Position</b>	A	Places a logo or text into your document as a Watermark using an image from removable media.	95
			B		
			C		
			D		
		<b>E*</b>			
		<b>Size</b>	Small		
			<b>Medium*</b>		
			Large		
		<b>Angle</b>	-90°		
			<b>-45°*</b>		
			0°		
			45°		
		<b>Transparency</b>	90°		
			-2		
			-1		
			<b>0*</b>		
			+1		
			+2		
		<b>Apply</b>	—		
<b>Scan</b>	(Set watermark document and press <b>Start</b> .)	<b>Transparency</b>	-2	Places a logo or text into your document as a Watermark using a scanned image.	96
			-1		
			<b>0*</b>		
			+1		
			+2		
		<b>Apply</b>	—		
 The factory settings are shown in Bold with an asterisk.					

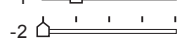
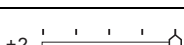
Photo Capture (  )

Level1	Level2	Level3	Options	Descriptions	Page
View Photo(s)	—	—	See the print settings in the following table.	You can preview your photos on the LCD.	103
Print Index	—	Layout Format	<b>6 Images/Line*</b> 5 Images/Line	You can print a thumbnail page.	104
		Paper Type	<b>Plain Paper*</b> Inkjet Paper Brother BP71 Other Glossy		
		Paper Size	<b>A4*</b> Letter		
Print Photos	—	—	See the print settings in the following table.	You can print an individual image.	105
Enhance Photos	Auto Correct Enhance Skin-Tone Enhance Scenery Remove Red-Eye Monochrome Sepia	—		You can adjust your photos with these settings.	105
Search by Date	—	—	—	You can search your photos from date.	108
Print All Photos	—	—	See the print settings in the following table.	You can print all photos in your memory card or USB Flash memory drive.	108
Slide show	—	—	—	The machine starts a Slide Show of your photos.	108
Trimming	—	—	—	You can trim your photo and print a part of the image.	109
 The factory settings are shown in Bold with an asterisk.					

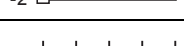
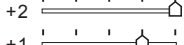
## Print Settings

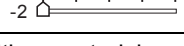
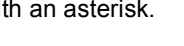
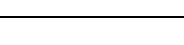
Option1	Option2	Option3	Option4	Descriptions	Page
<b>Print Quality</b> (Not available for DPOF printing)	Normal <b>Photo*</b>	—	—	Choose the print quality.	111
<b>Paper Type</b>	Plain Paper Inkjet Paper Brother BP71 <b>Other Glossy*</b>	—	—	Choose the paper type.	111
<b>Paper Size</b>	<b>10x15cm*</b> 13x18cm A4 A3 Letter Ledger	(When A4 or Letter is chosen)  8 x 10cm 9 x 13cm 10 x 15cm 13 x 18cm 15 x 20cm <b>Max. Size*</b>	—	Choose the paper and print size.	111
<b>Brightness</b> (Not available when Enhance Photos is chosen)	Light +2  +1  0  -1  -2  Dark	—	—	Adjusts the brightness.	112
<b>Contrast</b> (Not available when Enhance Photos is chosen)	+2  +1  0  -1  -2 	—	—	Adjusts the contrast.	112
<b>Color Enhance</b> (Not available when Enhance Photos is chosen)	On <b>Off*</b>	White Balance	+2  +1  0  -1  -2 	Adjusts the hue of the white areas.	112
		Sharpness	+2  +1  0  -1  -2 	Enhances the detail of the image.	
		Color Density	+2  +1  0  -1  -2 	Adjusts the total amount of colour in the image.	
 The factory settings are shown in Bold with an asterisk.					

Option1	Option2	Option3	Option4	Descriptions	Page
<b>Cropping</b>	<b>On*</b> Off	—	—	Crops the image around the margin to fit the paper size or print size. Turn this feature off if you want to print whole images or prevent unwanted cropping.	113
<b>Borderless</b>	<b>On*</b> Off	—	—	Expands the printable area to fit the edges of the paper.	113
<b>Date Print</b> (Not available for DPOF printing)	On <b>Off*</b>	—	—	Prints the date on your photo.	113
<b>Set New Default</b>	—	—	Yes No	You can save your print settings.	114
<b>Factory Reset</b>	—	—	Yes No	You can restore all the settings to factory settings.	114

 The factory settings are shown in Bold with an asterisk.

## Phone Book

Level1	Level2	Level3	Options	Descriptions	Page
<b>Search</b>	—	—	Alphabetical Order Numerical Order	You can dial by pressing only a few keys (and <b>Start</b> ).	73
<b>Set One Touch Dial</b>	—	—	—	Stores One Touch Dial numbers, so you can dial by pressing only a few keys (and <b>Start</b> ).	74
<b>Set Speed Dial</b>	—	—	—	Stores Speed Dial numbers, so you can dial by pressing only a few keys (and <b>Start</b> ).	76
<b>Setup Groups</b>	—	—	—	Sets up a Group number for Broadcasting.	79

 The factory settings are shown in Bold with an asterisk.

## Fax Preview

Level1	Level2	Level3	Options	Descriptions	Page
<b>Fax Preview</b>	—	—	On <b>Off*</b>	You can view received faxes (and faxes to be sent), on the LCD.	58

 The factory settings are shown in Bold with an asterisk.

## Entering Text

When you are setting certain menu selections, such as the Station ID, you may need to enter text into the machine. Most dial pad keys have three or four letters printed on keys. The keys for **0**, **#** and **\*** do not have printed letters because they are used for special characters.

By pressing the correct dial pad key repeatedly, you can access the character you want.

Press Key	one time	two times	three times	four times
<b>2</b>	A	B	C	2
<b>3</b>	D	E	F	3
<b>4</b>	G	H	I	4
<b>5</b>	J	K	L	5
<b>6</b>	M	N	O	6
<b>7</b>	P	Q	R	S
<b>8</b>	T	U	V	8
<b>9</b>	W	X	Y	Z

(MFC-6490CW only)

You can enter the lower case characters to set a E-mail address. Press **Shift+3** to change between upper case and lower case.

### Inserting spaces

To enter a space in a fax number, press **▶** once between numbers. To enter a space in a name, press **▶** twice between characters.

### Making corrections

If you entered an incorrect letter and want to change it, press **◀** to move the cursor under the incorrect character. Then press **Clear/Back**. Re-enter the correct character. You can also back up and insert letters.

### Repeating letters

If you need to enter a letter that is on the same key as the letter before, press **▶** to move the cursor to the right before you press the key again.

### Special characters and symbols

Press **\***, **#** or **0**, repeatedly until you see the special character or symbol you want.

Press **\*** for (space) ! " # \$ % & ' ( ) \* + , - . / €

Press **#** for : ; < = > ? @ [ ] ^ \_

Press **0** for Ä Ë Ö Ü À Ç È É 0

## General

<b>Printer Type</b>	Inkjet
<b>Print Method</b>	Mono: Piezo with 94 × 2 nozzle Colour: Piezo with 94 × 3 nozzles
<b>Memory Capacity</b>	64 MB
<b>LCD (liquid crystal display)</b>	Wide 3.3 in. (83.8 mm) Colour LCD
<b>Power Source</b>	AC 220 to 240V 50/60Hz
<b>Power Consumption</b>	(MFC-5890CN) Power Save Mode: Average 0.8 W Sleep Mode: Average 4.5 W Standby: Average 6 W Operating: Average 27 W (MFC-6490CW) Power Save Mode: Average 0.9 W Sleep Mode: Average 4.5 W Standby: Average 6 W Operating: Average 29 W

## Dimension

(MFC-5890CN)

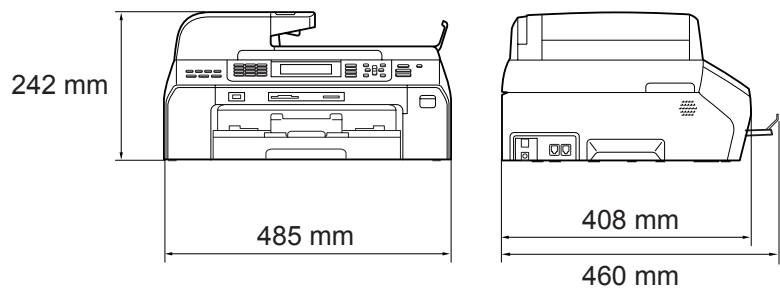

(MFC-6490CW)

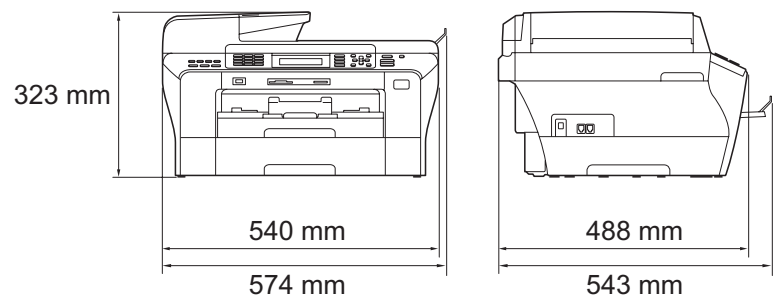

<b>Weight</b>	(MFC-5890CN)	10.9 kg
	(MFC-6490CW)	15.6 kg
<b>Noise</b>	Operating:	LPAM = 50 dB or less <sup>1</sup>
<b>Noise per ISO 9296</b>	(MFC-5890CN)	
	Operating:	LWAd = 64.3 dB (A) (Mono) LWAd = 61.6 dB (A) (Colour)
	(MFC-6490CW)	
	Operating:	LWAd = 64.1 dB (A) (Mono) LWAd = 55.2 dB (A) (Colour)
	Office equipment with LWAd > 63.0 dB (A) is not suitable for use in rooms where people do primarily intellectual work. Such equipment should be placed in separate rooms because of the noise emission.	
<b>Temperature</b>	Operating:	10 - 35° C
	Best Print Quality:	20 - 33° C
<b>Humidity</b>	Operating:	20 - 80% (without condensation)
	Best Print Quality:	20 - 80% (without condensation)
<b>ADF (automatic document feeder)</b>	Recommended environment for best results:	
	Up to 50 pages	
	Temperature: 20° C - 30° C	
	Humidity: 50% - 70%	
	Paper: 80 g/m <sup>2</sup>	
<b>Paper Tray #1</b>	150 Sheets 80 g/m <sup>2</sup> (MFC-5890CN and MFC-6490CW)	
<b>Paper Tray #2</b>	250 Sheets 80 g/m <sup>2</sup> (MFC-6490CW)	

<sup>1</sup> This depends on printing conditions.

# Print media

## Paper Input

### Paper Tray

- Paper type:

Plain paper, inkjet paper (coated paper), glossy paper <sup>2</sup>, transparencies <sup>1 2</sup> and envelopes

- Paper size:

Ledger, A3, Letter, Legal, Executive, A4, A5, A6, JIS B4, JIS B5, envelopes (commercial No.10, DL, C5, Monarch, JE4), Photo 10×15cm, Photo L, Photo 2L, Index card and Post card <sup>3</sup>.

Width: 89 mm - 297 mm

Length: 127 mm - 431.8 mm

For more details, see *Paper weight, thickness and capacity* on page 21.

- Maximum paper tray capacity:

Approx. 150 sheets of 80 g/m<sup>2</sup> plain paper

### Paper Tray #2 (MFC-6490CW only)

- Paper type:

Plain paper

- Paper size:

Ledger, A3, Letter, Legal, A4, JIS B5, JIS B4, EXE

Width: 182 mm - 297 mm

Length: 257 mm - 431.8 mm

For more details, see *Paper weight, thickness and capacity* on page 21.

- Maximum paper tray capacity:

Approx. 250 sheets of 80 g/m<sup>2</sup> plain paper

## Paper Output

Up to 50 sheets of A4 plain paper (face up print delivery to the output paper tray) <sup>2</sup>

<sup>1</sup> Use only transparencies recommended for inkjet printing.

<sup>2</sup> For glossy paper or transparencies, we recommend removing printed pages from the output paper tray immediately after they exit the machine to avoid smudging.

<sup>3</sup> See *Paper type and size for each operation* on page 20.

# Fax

<b>Compatibility</b>	ITU-T Super Group 3
<b>Coding System</b>	MH/MR/MMR/JPEG
<b>Modem Speed</b>	Automatic Fallback 33600 bps
<b>Document Size</b>	(MFC-5890CN) ADF Width: 148mm to 215.9 mm ADF Length: 148mm to 355.6 mm Scanner Glass Width: Max. 215.9 mm Scanner Glass Length: Max. 297 mm (MFC-6490CW) ADF Width: 148 mm to 297 mm ADF Length: 148 mm to 431.8 mm Scanner Glass Width: Max. 297 mm Scanner Glass Length: Max. 431.8 mm
<b>Scanning Width</b>	(MFC-5890CN) 208 mm (Letter paper) 204 mm (A4 paper) (MFC-6490CW) 288 mm
<b>Printing Width</b>	291 mm
<b>Greyscale</b>	256 levels
<b>Polling Types</b>	Standard, Secure, Timer Sequential: (Monochrome only)
<b>Contrast Control</b>	Automatic/Light/Dark (manual setting)

<b>Resolution</b>	<ul style="list-style-type: none"> <li>■ Horizontal 8 dot/mm</li> <li>■ Vertical <ul style="list-style-type: none"> <li>Standard</li> <li>3.85 line/mm (Mono)</li> <li>7.7 line/mm (Colour)</li> <li>Fine</li> <li>7.7 line/mm (Mono/Colour)</li> <li>Photo</li> <li>7.7 line/mm (Mono)</li> <li>Superfine</li> <li>15.4 line/mm (Mono)</li> </ul> </li> </ul>
<b>One Touch Dial</b>	6 (3 × 2)
<b>Speed Dial</b>	80 stations × 2 numbers (MFC-5890CN) 100 stations × 2 numbers (MFC-6490CW)
<b>Groups</b>	Up to 6
<b>Broadcasting</b> <sup>1</sup>	216 stations (MFC-5890CN) 256 stations (MFC-6490CW)
<b>Automatic Redial</b>	3 times at 5 minute intervals
<b>Ring Delay</b>	0, 1, 2, 3, 4, 5, 6, 7 or 8 rings (2, 3, 4, 5, 6, 7 or 8 rings - South Africa only) (0, 1, 2, 3, 4, or 5 rings - Nordic countries only)
<b>Communication Source</b>	Public switched telephone network.
<b>Memory Transmission</b>	Up to 480 <sup>2</sup> /400 <sup>3</sup> pages
<b>Out of Paper Reception</b>	Up to 480 <sup>2</sup> /400 <sup>3</sup> pages

<sup>1</sup> Monochrome only

<sup>2</sup> 'Pages' refers to the 'Brother Standard Chart No. 1' (a typical business letter, Standard resolution, MMR code). Specifications and printed materials are subject to change without prior notice.

<sup>3</sup> 'Pages' refers to the 'ITU-T Test Chart #1' (a typical business letter, Standard resolution, MMR code). Specifications and printed materials are subject to change without prior notice.

# Copy

## Colour/Monochrome

Yes/Yes

## Document Size

(MFC-5890CN)

ADF Width: 148 mm to 215.9 mm

ADF Length: 148 mm to 355.6 mm

Scanner Glass Width: Max. 215.9 mm

Scanner Glass Length: Max. 297 mm

Copy Width: Max. 210mm

(MFC-6490CW)

ADF Width: 148 mm to 297 mm

ADF Length: 148 mm to 431.8 mm

Scanner Glass Width: Max. 297 mm

Scanner Glass Length: Max. 431.8 mm

Copy Width: Max. 291 mm

## Resolution

■ Scans up to 1200×1200 dpi

■ Prints up to 1200×1200 dpi

# PhotoCapture Center™

D

<b>Compatible Media</b> <sup>1</sup>	CompactFlash® (Type I only) (Microdrive™ is not compatible) (Compact I/O cards such as Compact LAN card and Compact Modem card are not supported.)  Memory Stick®  Memory Stick Pro™  Memory Stick Duo™ with adapter Memory Stick Micro (M2) with adapter SD <sup>2</sup> SDHC <sup>3</sup> microSD with adapter miniSD™ with adapter xD-Picture Card™ <sup>4</sup> USB Flash memory drive <sup>5</sup>
<b>Resolution</b>	Up to 1200 × 2400 dpi
<b>File Extension</b>	
(Media Format)	DPOF, EXIF, DCF
(Image Format)	Photo Print: JPEG <sup>6</sup> Scan to Media: JPEG, PDF (Colour) TIFF, PDF (Mono)
<b>Number of Files</b>	Up to 999 files (The folder inside memory cards or USB Flash memory drive is also counted)
<b>Folder</b>	File must be stored in the 4th folder level of the memory card or USB Flash memory drive.
<b>Borderless</b>	Ledger, A3, Letter, A4, Photo (10×15 cm), Photo 2L (13×18 cm) <sup>7</sup>

<sup>1</sup> Memory cards, adapters and USB Flash memory drive are not included.

<sup>2</sup> 16MB to 2GB

<sup>3</sup> 4GB to 8GB

<sup>4</sup> xD-Picture Card™ Conventional Card from 16MB to 512MB

xD-Picture Card™ Type M from 256MB to 2GB

xD-Picture Card™ Type M+ 1GB and 2GB

xD-Picture Card™ Type H from 256MB to 2GB

<sup>5</sup> USB 2.0 Standard

USB Mass Storage standard from 16 MB to 8 GB

Support format: FAT12/FAT16/FAT32

<sup>6</sup> Progressive JPEG format is not supported.

<sup>7</sup> See *Paper type and size for each operation* on page 20.

# PictBridge

## **Compatibility**

Supports the Camera & Imaging Products Association PictBridge standard CIPA DC-001.

Visit <http://www.cipa.jp/pictbridge> for more information.

## **Interface**

USB direct interface

# Scanner

<b>Colour/Monochrome</b>	Yes/Yes
<b>TWAIN Compliant</b>	Yes (Windows® 2000 Professional/XP/XP Professional x64 Edition/Windows Vista®) Mac OS® X 10.2.4 or greater
<b>WIA Compliant</b>	Yes (Windows® XP <sup>1</sup> /Windows Vista®)
<b>Colour Depth</b>	48 bit colour Processing (Input) 24 bit colour Processing (Output) (Actual Input: 30 bit colour/Actual Output: 24 bit colour)
<b>Resolution</b>	Up to 19200 × 19200 dpi (interpolated) <sup>2</sup> Up to 1200 × 2400 dpi (optical) (Scanner Glass) Up to 1200 × 600 dpi (optical) (ADF)
<b>Scanning Speed</b>	(MFC-5890CN) Monochrome: up to 3.44 sec. Colour: up to 4.83 sec. (MFC-6490CW) Monochrome: up to 3.39 sec. Colour: up to 4.49 sec. (A4 size at 100 × 100 dpi)
<b>Document Size</b>	(MFC-5890CN) ADF Width: 148 mm to 215.9 mm ADF Length: 148 mm to 355.6 mm Scanner Glass Width: Max. 215.9 mm Scanner Glass Length: Max. 297 mm (MFC-6490CW) ADF Width: 148 mm to 297 mm ADF Length: 148 mm to 431.8 mm Scanner Glass Width: Max. 297 mm Scanner Glass Length: Max. 431.8 mm
<b>Scanning Width</b>	(MFC-5890CN) 210 mm (MFC-6490CW) Up to 291 mm
<b>Greyscale</b>	256 levels

<sup>1</sup> Windows® XP in this User's Guide includes Windows® XP Home Edition, Windows® XP Professional, and Windows® XP Professional x64 Edition.

<sup>2</sup> Maximum 1200 × 1200 dpi scanning when using the WIA Driver for Windows® XP and Windows Vista® (resolution up to 19200 × 19200 dpi can be selected by using the Brother scanner utility)

# Printer

<b>Printer Driver</b>	Windows® 2000 Professional/XP/XP Professional x64 Edition/Windows Vista® driver supporting Brother Native Compression mode
	Mac OS® X 10.2.4 or greater: Brother Ink Driver
<b>Resolution</b>	Up to 1200 × 6000 dpi 1200 × 2400 dpi 1200 × 1200 dpi 600 × 600 dpi 600 × 300 dpi 600 × 150 dpi (Colour) 450 × 300 dpi (Mono)
<b>Print Speed</b>	Up to 35 pages/minute (Mono) <sup>1</sup> Up to 28 pages/minute (Colour) <sup>1</sup>
<b>Printing Width</b>	291 mm (297 mm) <sup>2</sup> (A3 size)
<b>Borderless</b>	Ledger, A3, Letter, A4, A6, B4, Photo (10×15 cm), Photo L (89×127 mm), Photo 2L (13×18 cm), Index Card, Post Card <sup>3</sup>

<sup>1</sup> Based on Brother standard pattern.  
A4 size in draft mode.

<sup>2</sup> When you set the Borderless feature to On.

<sup>3</sup> See *Paper type and size for each operation* on page 20.

# Interfaces

**USB**<sup>1 2</sup>

A USB 2.0 interface cable that is no longer than 2.0 m.

**LAN cable**<sup>3</sup>

Ethernet UTP cable category 5 or greater.

**Wireless LAN  
(MFC-6490CW)**

Your machine supports IEEE 802.11b/g wireless communication with your wireless LAN using Infrastructure mode or a wireless Peer-to-Peer connection in Ad-hoc Mode.

- <sup>1</sup> Your machine has a Hi-speed USB 2.0 interface. The machine can also be connected to a computer that has a USB 1.1 interface.
- <sup>2</sup> Third party USB ports are not supported for Macintosh®.
- <sup>3</sup> See the *Network User's Guide* for detailed network specifications.

# Computer requirements

SUPPORTED OPERATING SYSTEMS AND SOFTWARE FUNCTIONS									
Computer Platform & Operating System Version		Supported PC Software Functions	PC Interface	Processor Minimum Speed	Minimum RAM	Recommended RAM	Hard Disk Space to install		
							For Drivers	For Applications	
Windows® Operating System <sup>1</sup>	2000 Professional <sup>5</sup>	Printing, PC Fax <sup>4</sup> , Scanning, Removable Disk	USB, 10/100 BaseTx (Ethernet), Wireless 802.11b/g (MFC-6490CW only)	Intel® Pentium® II or equivalent	64 MB	256 MB	110 MB	340 MB	
	XP Home <sup>2 5</sup>				128 MB			110 MB	340 MB
	XP Professional <sup>2 5</sup>				64-bit (Intel®64 or AMD64) supported CPU	256 MB	512 MB	110 MB	340 MB
	XP Professional x64 Edition <sup>2</sup>				Intel® Pentium® 4 or equivalent	512 MB	1 GB	600 MB	530 MB
	Windows Vista® <sup>2</sup>			64-bit (Intel®64 or AMD64) supported CPU					
Macintosh® Operating System <sup>6</sup>	Mac OS® X 10.2.4 - 10.4.3	Printing, PC Fax Send <sup>4</sup> , Scanning, Removable Disk	USB <sup>3</sup> , 10/100 BaseTx (Ethernet), Wireless 802.11b/g (MFC-6490CW only)	PowerPC G4/G5	128 MB	256 MB	80 MB	400 MB	
	Mac OS® X 10.4.4 or greater				PowerPC G3 350MHz				
				Intel® Core™ Processor					

## Conditions:

- <sup>1</sup> Microsoft® Internet Explorer 5.5 or greater.
- <sup>2</sup> For WIA, 1200 x 1200 resolution. Brother Scanner Utility enables to enhance up to 19200 x 19200 dpi.
- <sup>3</sup> Third party USB ports are not supported.
- <sup>4</sup> PC Fax supports black and white only, and does not support Ledger/A3 size paper.
- <sup>5</sup> PaperPort™ 11SE supports Microsoft® SP4 or higher for Windows® 2000 and SP2 or higher for XP.
- <sup>6</sup> Presto!® PageManager® on the CD-ROM supports Mac OS® X 10.3.9 or higher. For Mac OS® X 10.2.4-10.3.8 Presto!® PageManager® is available as a download from the Brother Solutions Center.

For the latest driver updates, visit <http://solutions.brother.com/>  
All trademarks, brand and product names are property of their respective companies.

## Consumable items

**Ink** The machine uses individual Black, Yellow, Cyan and Magenta ink cartridges that are separate from the print head assembly.

**Service Life of Ink Cartridge**

**Replacement Ink Cartridges**

The first time you install a set of ink cartridges the machine will use an amount of ink to fill the ink delivery tubes for high quality printouts. This process will only happen once. With all following ink cartridges you can print the specified number of pages.

For more information about the replacement consumables, visit us at [www.brother.com/pageyield](http://www.brother.com/pageyield).

**Replacement Consumables**

<Standard Black> LC1100BK, <High Yield Black> LC1100HY-BK  
 <Standard Cyan> LC1100C, <High Yield Cyan> LC1100HY-C  
 <Standard Magenta>LC1100M, <High Yield Magenta>LC1100HY-M  
 <Standard Yellow> LC1100Y, <High Yield Yellow> LC1100HY-Y

**What is Innobella™?**

Innobella™ is a range of genuine consumables offered by Brother. The name "Innobella™" derives from the words "Innovation" and "Bella" (meaning "Beautiful" in Italian) and is a representation of the "innovative" technology providing you with "beautiful" and "long lasting" print results.



When you print photo images, Brother recommends Innobella™ glossy photo paper (BP71 series) for high quality. Brilliant prints are made easier with Innobella™ Ink and paper.

# Network (LAN)

<b>LAN</b>	You can connect your machine to a network for Network Printing, Network Scanning, PC Fax Send, PC Fax Receive (Windows® only) and Remote Setup <sup>1</sup> . Also included is Brother BRAdmin Light <sup>2</sup> Network Management software.	
<b>Support for</b>	Windows® 2000 Professional/XP/XP Professional x64 Edition/ Windows Vista®	
	Mac OS® X 10.2.4 or greater	
	Ethernet 10/100 BASE-TX Auto Negotiation (Wired LAN)	
	IEEE 802.11 b/g (Wireless LAN)	
<b>Protocols</b>	TCP/IP for IPv4:	ARP, RARP, BOOTP, DHCP, APIPA (Auto IP), NetBIOS/WINS, LPR/LPD, Custom Raw Port/Port9100, DNS Resolver, mDNS, FTP Server, TELNET, SNMPv1, TFTP, Scanner Port, LLTD responder, Web Services, SMTP Client, POP before SMTP, SMTP-AUTH, POP3, APOP, FTP Client
	TCP/IP for IPv6:	(Turned off as default) NDP, RA, LPR/LPD, Custom Raw Port/Port9100, mDNS, FTP Server, TELNET, SNMPv1, TFTP, Scanner Port, LLTD responder, Web Services, SMTP Client, POP before SMTP, SMTP-AUTH, POP3, APOP, FTP Client
<b>Network Security</b>	SSID/ESSID, 128 (104) / 64 (40) bit WEP, WPA/WPA2-PSK (TKIP/AES)	
<b>Setup Support Utility (MFC-6490CW only)</b>	<b>SecureEasySetup™</b>	Yes (simple setup with your SecureEasySetup™-capable access point/router)
	<b>AOSS™</b>	Yes (simple setup with your AOSS™-capable access point/router)
	<b>WPS</b>	Yes (simple setup with your Wi-Fi Protected Setup™-capable access point/router)

<sup>1</sup> See the Computer Requirements chart on page 206.

<sup>2</sup> If you require more advanced printer management, use the latest Brother BRAdmin Professional utility version that is available as a download from <http://solutions.brother.com>.

## Wireless one-push configuration

---

If your wireless access point supports either SecureEasySetup™, Wi-Fi Protected Setup™ (PBC<sup>1</sup>) or AOSS™, you can configure the machine easily without a computer. By pushing a button on the wireless LAN router / access point and the machine, you can set up the wireless network and security settings. See the users guide for your wireless LAN router / access point for instructions on how to access one-push mode.

<sup>1</sup> Push Button Configuration



### Note

---

Routers or access points that support SecureEasySetup™, Wi-Fi Protected Setup™ or AOSS™ have the symbols shown below.



# E

## Glossary

This is a comprehensive list of features and terms that appear in Brother manuals. Availability of these features depends on the model you purchased.

### **ADF (automatic document feeder)**

The document can be placed in the ADF and scanned one page at a time automatically.

### **Auto Reduction**

Reduces the size of incoming faxes.

### **Automatic fax transmission**

Sending a fax without picking up the handset of an external telephone.

### **Automatic Redial**

A feature that enables your machine to redial the last fax number after five minutes if the fax did not go through because the line was busy.

### **Backup Print**

Your machine prints a copy of every fax that is received and stored in memory. This is a safety feature so you will not lose messages during a power failure.

### **Batch Transmission**

(Black and white faxes only) As a cost saving feature, all delayed faxes to the same fax number can be sent as one transmission.

### **Beeper Volume**

Volume setting for the beep when you press a key or make an error.

### **Brightness**

Changing the Brightness makes the whole image lighter or darker.

### **Broadcasting**

The ability to send the same fax message to more than one location.

### **Caller ID**

A service purchased from the telephone company that lets you see the number (or name) of the party calling you.

### **CNG tones**

The special tones (beeps) sent by fax machines during automatic transmission to tell the receiving machine that a fax machine is calling.

### **Coding method**

Method of coding the information contained in the document. All fax machines must use a minimum standard of Modified Huffman (MH). Your machine is capable of greater compression methods, Modified Read (MR), Modified Modified Read (MMR) and JPEG, if the receiving machine has the same capability.

### **Colour Enhancement**

Adjusts the colour in the image for better print quality by improving sharpness, white balance and colour density.

### **Communication error (Comm. Error)**

An error during fax sending or receiving, usually caused by line noise or static.

### **Compatibility group**

The ability of one fax unit to communicate with another. Compatibility is assured between ITU-T Groups.

### **Contrast**

Setting to compensate for dark or light documents, by making faxes or copies of dark documents lighter and light documents darker.

### **Delayed Fax**

Sends your fax at a specified time later.

### **Dual Access**

Your machine can scan outgoing faxes or scheduled jobs into memory at the same time it is sending a fax from memory or receiving or printing an incoming fax.

**ECM (Error Correction Mode)**

Detects errors during fax transmission and resends the pages of the fax that had an error.

**Extension telephone**

A telephone using the same line as your fax but plugged into a separate wall socket.

**External telephone**

A TAD (telephone answering device) or telephone that is connected to your machine.

**F/T Ring Time**

The length of time that the Brother machine rings (when the Receive Mode setting is Fax/Tel) to notify you to pick up a voice call that it answered.

**Fax Detect**

Enables your machine to respond to CNG tones if you interrupt a fax call by answering it.

**Fax Forwarding**

Sends a fax received into the memory to another pre-programmed fax number.

**Fax Journal**

Lists information about the last 200 incoming and outgoing faxes. TX means Transmit. RX means Receive.

**Fax Preview**

If you choose Fax Preview you will be able to view received faxes on the LCD by pressing the **Fax Preview** key.

**Fax Storage**

You can store received faxes in memory.

**Fax tones**

The signals sent by sending and receiving fax machines while communicating information.

**Fax/Tel**

You can receive faxes and telephone calls. Do not use this mode if you are using a telephone answering device (TAD).

**Fine resolution**

Resolution is 203 × 196 dpi. It is used for small print and graphs.

**Greyscale**

The shades of grey available for copying, scanning and faxing photographs.

**Group number**

A combination of One Touch and Speed Dial numbers that are stored on a One Touch key or in a Speed Dial location for Broadcasting.

**Help list**

A printout of the complete Menu table that you can use to program your machine when you do not have the User's Guide with you.

**Innobella™**

Innobella™ is a range of genuine consumables offered by Brother. For best quality results Brother recommends Innobella™ Ink and Paper.

**Journal Period**

The pre-programmed time period between automatically printed Fax Journal Reports. You can print the Fax Journal on demand without interrupting the cycle.

**LCD (liquid crystal display)**

The display screen on the machine that shows interactive messages during On-Screen Programming and shows the date and time when the machine is idle.

**Manual fax**

When you lift the handset of your external telephone you can hear the receiving fax machine answer before you press **Mono Start** or **Colour Start** to begin sending the fax.

**Memory Receive**

Receives faxes into the machine's memory when the machine is out of paper.

**Menu mode**

Programming mode for changing your machine's settings.

### **OCR (optical character recognition)**

The bundled ScanSoft™ PaperPort™ 11SE with OCR or Presto!®

PageManager® software application converts an image of text to text you can edit.

### **One Touch**

Keys on the machine's control panel where you can store numbers for easy dialling. You can store a second number on each key if you hold down **Shift** as you press the One Touch key.

### **Overseas Mode**

Makes temporary changes to the fax tones to accommodate noise and static on overseas telephone lines.

### **Pause**

Allows you to place a 3.5 second delay in the dialling sequence while you are dialling using the dial pad or while you are storing One Touch and Speed Dial numbers. Press **Redial/Pause** as many times as needed for longer pauses.

### **Photo resolution (Mono only)**

A resolution setting that uses varying shades of grey for the best representation of photographs.

### **PhotoCapture Center™**

Allows you to print digital photos from your digital camera at high resolution for photo quality printing.

### **PictBridge**

Allows you to print photos directly from your digital camera at high resolution for photo quality printing.

### **Polling**

The process of a fax machine calling another fax machine to retrieve waiting fax messages.

### **Pulse**

A form of rotary dialling on a telephone line.

### **Quick Dial List**

A listing of names and numbers stored in One Touch and Speed Dial memory, in numerical order.

### **Real Time Transmission**

When memory is full, you can send faxes in real time.

### **Remaining jobs**

You can check which jobs are waiting in memory and cancel jobs individually.

### **Remote Access Code**

Your own four-digit code (---\*) that allows you to call and access your machine from a remote location.

### **Remote Activation Code**

Press this code (\* 5 1) when you answer a fax call on an extension or external telephone.

### **Remote Deactivation Code (For Fax/Tel mode only)**

When the machine answers a voice call, it pseudo/double-rings. You can pick up at an extension telephone by pressing this code (# 5 1).

### **Remote Retrieval Access**

The ability to access your machine remotely from a touch tone telephone.

### **Resolution**

The number of vertical and horizontal lines per inch. See: Standard, Fine, Super Fine and Photo.

### **Ring Delay**

The number of rings before the machine answers in Fax Only and Fax/Tel modes.

### **Ring Volume**

Volume setting for the machine's ring.

### **Scan to Media**

You can scan a monochrome or colour document into a memory card or USB Flash memory drive. Monochrome images will be in TIFF or PDF file format and colour images may be in PDF or JPEG file format.

**Scanning**

The process of sending an electronic image of a paper document into your computer.

**Search**

An electronic, numerical or alphabetical listing of stored One Touch, Speed Dial and Group numbers.

**Speed Dial**

A pre-programmed number for easy dialling. You must press

 (**Phone Book**), the two digit code, and **Mono Start** or **Colour Start** to start the dialling process.

**Standard resolution**

203 × 97 dpi. It is used for regular size text and quickest transmission.

**Station ID**

The stored information that appears on the top of faxed pages. It includes the sender's name and fax number.

**Super Fine resolution (Mono only)**

392 × 203 dpi. Best for very small print and line art.

**TAD (telephone answering device)**

You can connect an external TAD to your machine.

**Temporary settings**

You can choose certain options for each fax transmission and copy without changing the default settings.

**Tone**

A form of dialling on the telephone line used for Touch Tone telephones.

**Transmission**

The process of sending faxes over the phone lines from your machine to the receiving fax machine.

**User Settings**

A printed report that shows the current settings of the machine.

**Xmit Report (Transmission Verification Report)**

A listing for each fax sent, that shows its date, time and number.

- A**
- 
- Access codes, storing and dialling .....80
  - ADF (automatic document feeder) .... 22, 40
  - Answering machine (TAD) .....67
    - connecting .....68
  - Apple® Macintosh®
    - See Software User's Guide on the CD-ROM. ....
  - Automatic
    - fax receive .....49
    - Fax Detect .....52
- B**
- 
- Broadcasting .....43
    - setting up Groups for .....79
- C**
- 
- Caller ID .....65
  - Caller ID history .....74
  - Caller ID History report .....83
  - Cancelling
    - Fax Forwarding .....62
    - jobs awaiting redial .....47
  - Cleaning
    - paper pick-up roller .....162
    - print head .....162
    - printer platen .....161
    - scanner .....161
  - Connecting
    - external TAD (answering machine) ..... 67, 68
    - external telephone .....69
  - Consumable items .....207
  - Control panel overview .....6
  - ControlCenter
    - See Software User's Guide on the CD-ROM. ....
- Copy**
- book ..... 94
  - brightness ..... 92
  - contrast ..... 93
  - enlarge/reduce ..... 89
  - enter Copy mode ..... 88
  - multiple ..... 88
  - out of memory ..... 97
  - page layout (N in 1) ..... 90
  - paper size ..... 93
  - paper type ..... 93
  - quality ..... 89
  - return to default ..... 96
  - set new default ..... 96
  - single ..... 88
  - sort (ADF only) ..... 92
  - tray use ..... 28
  - using ADF ..... 92
  - using scanner glass ..... 23
  - watermark ..... 95
    - using a media card ..... 95
    - using a paper document ..... 96
    - using a template ..... 95
    - using a USB Flash memory drive ..... 95
- Cordless telephone** ..... 70
- Custom telephone features on a single line** ..... 140
- D**
- 
- Dialling**
- a pause ..... 74
  - access codes and credit card numbers ..... 78
  - Caller ID history ..... 74
  - Groups ..... 43
  - manual ..... 72
  - One Touch ..... 72
  - Outgoing Call ..... 73
  - Speed Dial ..... 72
- Direct printing**
- from a non-PictBridge camera ..... 120
  - from a PictBridge camera ..... 118
- Document**
- loading ..... 22, 23
- Dual Access** ..... 46

## E

---

Envelopes .....	15, 20, 21
Error messages on LCD .....	144
B&W Print Only .....	144
Cannot Detect .....	145
Cannot Print .....	145
Comm. Error .....	145
Ink low .....	146
No Cartridge .....	146
No Paper Fed .....	147
Not Registered .....	72, 147
Out of Memory .....	147
while scanning a document .....	97
Unable to Clean .....	148
Unable to Init. ....	148
Unable to Print .....	148
Unable to Scan .....	149
Extension telephone, using .....	69
External telephone, connecting .....	69

## F

---

Fax codes	
changing .....	60, 71
Remote Access Code .....	60
Remote Activation Code .....	52, 69, 70
Remote Deactivation Code .....	69, 70
using .....	70
Fax Detect .....	52
Fax Forwarding	
changing remotely .....	62, 63
programming a number .....	55
Fax Storage .....	55
printing from memory .....	54
turning on .....	55
Fax, from PC	
See Software User's Guide on the CD-ROM. ....	
Fax, stand-alone	
receiving .....	49
at end of conversation .....	50
difficulties .....	136, 138
F/T Ring Time, setting .....	51
Fax Detect .....	52
Fax Forwarding .....	62
Fax Preview .....	58, 60
from extension telephone .....	69, 70
from external telephone .....	69, 70

into PC .....	56
printing from memory .....	54
reducing to fit on paper .....	52
retrieving from a remote site .....	62, 63
Ring Delay, setting .....	51
telephone line interference .....	143
tray use .....	28
sending .....	40, 84
Broadcasting .....	43
cancelling from memory .....	47
contrast .....	45
delayed batch transmission .....	47
delayed fax .....	46
enter Fax mode .....	40
from ADF .....	40
from memory (Dual Access) .....	46
from scanner glass .....	41
manual .....	48
overseas .....	46
Real Time Transmission .....	46
Resolution .....	45
return to factory setting .....	47
set new default .....	47
telephone line interference .....	143
Fax/Tel mode	
answering at extension	
telephones .....	69, 70
Remote Activation Code .....	69, 70
Remote Deactivation Code .....	69, 70
Ring Delay .....	51
Function Lock .....	33

## G

---

Greyscale .....	198, 203
Groups for Broadcasting .....	79

## H

---

Help	
LCD messages .....	168
using Mode and menu keys .....	168
Menu Table .....	168, 169

## I

Ink cartridges	
checking ink volume .....	165
ink dot counter .....	157
replacing .....	157
Innobella™ .....	207

## J

Jacks	
EXT	
external telephone .....	67
TAD (answering machine) .....	67
Jams	
document .....	151
paper .....	151

## L

LCD (liquid crystal display) .....	168
Brightness .....	31, 32
Contrast .....	31
Dim Timer .....	32
Help List .....	83
Loading envelopes and post cards .....	15
Loading paper .....	9

## M

Macintosh®	
See Software User's Guide on the CD-ROM. ....	
Maintenance, routine	
replacing ink cartridges .....	157
Manual	
dialling .....	72
receive .....	49
transmission .....	48
Memory Security .....	86
Memory Storage .....	168
Menu Table .....	168
Mode, entering	
Copy .....	88
Fax .....	40
PhotoCapture .....	6
Scan .....	6
Multi-line connections (PBX) .....	68

## N

Network	
Printing	
See Network User's Guide on the CD-ROM. ....	
Scanning	
See Software User's Guide on the CD-ROM. ....	

## O

One touch	
setting up .....	74
Out of Area (Caller ID) .....	65

## P

Packing the machine .....	165
Paper .....	15, 18, 197
capacity .....	21
loading .....	9, 12, 15
printable area .....	17
size .....	27
size of document .....	22
type .....	20, 26, 27
PaperPort™ 11SE with OCR	
See Software User's Guide on the CD-ROM and Help in the PaperPort™ 11SE application to access How-to-Guides. ....	
PhotoCapture Center™	
Adding Effect .....	105
Borderless .....	113
CompactFlash® .....	100
Cropping .....	113
DPOF printing .....	109
Enhance Photos	
Auto Correct .....	105
Enhance Scenery .....	106
Enhance Skin-Tone .....	106
Monochrome .....	107
Remove Red-Eye .....	107
Sepia .....	107
from PC	
See Software User's Guide on the CD-ROM. ....	
Memory Stick Pro™ .....	100
Memory Stick® .....	100

Preview photos .....	103
Print settings	
Brightness .....	112
Colour enhancement .....	112
Contrast .....	112
Paper type & size .....	111
Quality .....	110, 111
Return to factory setting .....	114
Set new default .....	114
Printing	
all photos .....	108
index .....	104
photos .....	105
Scan to memory card .....	114
Scan to USB flash memory .....	114
SD .....	100
SDHC .....	100
Search by Date .....	108
Slide-Show .....	108
specifications .....	201
Trimming .....	109
xD-Picture Card™ .....	100
PictBridge	
DPOF Printing .....	119
Power failure .....	168
Presto!® PageManager®	
See Help in Presto!® PageManager®	
application .....	
Print	
difficulties .....	136, 138
drivers .....	204
fax from memory .....	54
paper jams .....	152, 154
printable area .....	17
report .....	83
resolution .....	204
specifications .....	204
Printing	
on small paper .....	16
See Software User's Guide on the	
CD-ROM. ....	
Programming your machine .....	168

## Q

Quick Dial .....	74
Broadcasting .....	43
using Groups .....	43
Group dial	
changing .....	75, 77, 78
setting up Groups for Broadcasting ...	79
One Touch Dial	
custom scan profile .....	74
setting up .....	74
Search .....	73
Speed Dial	
changing .....	75, 77, 78
setting up by 2-digit location .....	76
setting up from Caller ID	
history .....	75, 77
setting up from outgoing calls .....	75, 77
using .....	72

## R

Receive Mode	
External TAD .....	49
Fax Only .....	49
Fax/Tel .....	49
Manual .....	49
Redial/Pause .....	73
Reducing	
copies .....	89
incoming faxes .....	52
Remote Retrieval .....	60
access code .....	60, 61
commands .....	62
getting your faxes .....	63
Remote Setup	
See Software User's Guide on the	
CD-ROM. ....	
Reports .....	82
Caller ID History Report .....	83
Fax Journal .....	83
Journal Period .....	83
Help List .....	83
how to print .....	83
Network Configuration .....	83
Quick Dial List .....	83
Transmission Verification .....	82, 83
User Settings .....	83

Resolution	
copy .....	200
fax .....	198
print .....	204
scan .....	203
setting for next fax .....	45
Restricted users .....	35
Ring Delay, setting .....	51

## S

---

Safety Instructions .....	127, 131
Scannable area .....	24
Scanning	
See Software User's Guide on the CD-ROM. ....	
Security	
Secure function lock	
administrator password .....	33
Public user .....	34
restricted users .....	35
Serial Number	
how to find .....	See inside front cover
Shipping the machine .....	165
Sleep Mode .....	31
Speed Dial	
changing .....	75, 77, 78
dialling .....	72
storing .....	76

## T

---

TAD (telephone answering device),	
external .....	49, 67
connecting .....	67, 68
receive mode .....	49
recording OGM .....	68
Tel/R key, using .....	6
Telephone line	
connections .....	68
difficulties .....	139
interference .....	143
multi-line (PBX) .....	68
type .....	66
Text, entering .....	194
special characters .....	194
Transferring your faxes or Fax Journal report .....	150
Transparencies .....	18, 19, 21, 197
Tray Select key .....	93

Troubleshooting .....	136
checking ink volume .....	165
document jam .....	151
error messages on LCD .....	144
if you are having difficulty	
copying .....	140
document jam .....	151
incoming calls .....	140
Network .....	142
PhotoCapture Center™ .....	141
printing .....	136
printing received faxes .....	138
receiving faxes .....	139
scanning .....	140
software .....	141
telephone line or connections .....	139
paper jam .....	152, 154

## V

---

Volume, setting	
beeper .....	30
ring .....	29
speaker .....	30

## W

---

Windows®	
See Software User's Guide on the CD-ROM. ....	
Wireless Network	
See Quick Setup Guide and Network User's Guide on the CD-ROM. ....	

# brother®

**Visit us on the World Wide Web**  
**<http://www.brother.com>**

This machine is approved for use in the country of purchase only. Local Brother companies or their dealers will only support machines purchased in their own countries.