

**WARRANTY
REGISTRATION:**
register online today for a
chance to win a FREE Tripp Lite
product—www.tripplite.com/warranty



Owner's Manual

Medical-Grade Mobile Power Retrofit Kit

Models: HCRK-54 & HCRK-36

Kit Includes: Power Supply Module, Battery Module (HCRK-54 = 54 amp-hour;
HCRK-36 = 36 amp-hour), Remote User Interface (RUI),
PowerAlert Data-Saving Software, Mounting Hardware and Cables.

Fully tested, certified and compliant with:

• UL 60601-1 • CAN/CSA-C22.2 No. 601.1-M90 • UL 1778 by



NOM **FC**



Important Safety Instructions	2
Mounting (Power Supply & Battery Module)	3
Connection / Start-Up	8
Operation	10
Features	11
Troubleshooting	13
Storage & Service	14
Safety & Regulatory Statements	15
Warranty & Warranty Registration	15



1111 W. 35th Street, Chicago, IL 60609 USA
www.tripplite.com/support

Copyright © 2010 Tripp Lite. All rights reserved.

Important Safety Instructions



Tripp Lite's Medical-Grade, Mobile Power Retrofit Kit includes two modules: a Power Supply Module and a Battery Module. When the two modules are connected (and attached to a remote user interface), they provide AC power for a variety of equipment on mobile carts. The following instructions refer to the kit as a single unit as well as its component parts.

SAVE THESE INSTRUCTIONS

This manual contains instructions and warnings that should be followed during the installation, operation and storage of all Tripp Lite Medical-Grade, Mobile Power Retrofit Kits. Failure to heed these warnings may affect your warranty.

Power Supply Module & Battery Module Location Warnings

- Your Power Supply Module incorporates fusing only in the ungrounded phase conductor. UL 60601-1 certified Power Supply Modules must not be used in countries other than the United States and Canada and must be used only in health care facilities on grounded systems where conditions of maintenance and supervision ensure that only qualified persons will service the electrical distribution system.
- Install your Power Supply Module and Battery Module indoors, away from excess moisture or heat, dust or direct sunlight and conductive contaminants.
- Although the Power Supply Module is designed to support computer equipment, do not install it in direct contact with magnetic storage media, as this may result in data corruption.
- For best performance, keep the indoor temperature between 32° F and 104° F (0° C and 40° C).
- Leave adequate space around all sides of the Power Supply Module and Battery Module for proper ventilation.

Power Supply Module Connection Warnings

- Do not operate the Power Supply Module without connecting it to a Battery Module and the Remote User Interface (RUI). The Power Supply Module will not operate (with or without utility power) until the Battery Module and RUI are connected.
- Do not allow objects to contact the Power Supply Module's two DC input terminals. Do not short or bridge these terminals together. Serious personal injury or property damage could result.
- Connect your Power Supply Module directly to a properly grounded AC power outlet. Do not plug the Power Supply Module into itself; this will damage the unit. The Power Supply Module features a hospital-grade plug. If the plug is connected to a wall outlet that is not hospital-grade, the unit may not be properly grounded.
- Do not modify the Power Supply Module's plug, and do not use an adapter that would eliminate the Power Supply Module's ground connection.
- Do not use extension cords to connect the Power Supply Module to an AC outlet.
- If the Power Supply Module receives power from a motor-powered AC generator, the generator must provide clean, filtered, computer-grade output.

Equipment Connection Warnings

- Use of this equipment in life support applications where failure of this equipment can reasonably be expected to cause the failure of the life support equipment or to significantly affect its safety or effectiveness is not recommended. Do not use this equipment in the presence of a flammable anesthetic mixture with air, oxygen or nitrous oxide.
- The Power Supply Module is designed to accept connection of equipment mounted on the same mobile cart. Connecting equipment which is not mounted on the same cart as the Power Supply Module could pose a safety hazard.
- Do not connect surge suppressors or extension cords to the output of your Power Supply Module. This may damage the Power Supply Module and may affect the surge suppressor and Power Supply Module warranties.



Battery Module Warnings

- Do not allow objects to contact the Battery Module's two DC input terminals. Do not short or bridge these terminals together. Serious personal injury or property damage could result.
- It is normal for sparks to occur when connecting the Battery Module to the Power Supply Module.
- Due to the possibility of dangerous arcing, do not unplug the Battery Module from the Power Supply Module while the Power Supply Module is operating from battery power (whenever the cart is mobile and the Power Supply Module is not plugged into a live utility wall outlet, or during a power outage).
- Your Battery Module does not require routine maintenance. Do not open your Battery Module for any reason. There are no user-serviceable parts inside. The batteries in the Battery Module will eventually wear out and be unable to provide adequate run times. Internal battery replacement must be performed by factory authorized service personnel. Because batteries present a risk of electrical shock and burn from high short-circuit current, service personnel should observe proper precautions. Unplug the Battery Module before performing battery replacement. Do not short or bridge battery terminals with any object. Use tools with insulated handles. Remove metal objects such as watches and rings before working with batteries. Do not open batteries. Replace batteries only with sealed lead-acid batteries of the same number, type, voltage and amp-hour capacity. Contact Tripp Lite for details.
- Tripp Lite offers additional replacement Battery Modules [compatible models: BP12V54 (54 amp-hour); BP12V36 (36 amp-hour)]. Contact Tripp Lite for details.
- The Battery Module's internal batteries are recyclable. Refer to local codes for disposal requirements, or visit www.triplite.com/UPSbatteryrecycling for recycling information. Do not dispose of the batteries in a fire.
- If connecting a replacement Battery Module to the Power Supply Module, the Battery Module must have the same voltage as the Power Supply Module. Use only Tripp Lite Battery Modules [compatible models: BP12V54 (54 amp-hour); BP12V36 (36 amp-hour)] with the Power Supply Module.

Labeling Symbols

AC Voltage: V ~

DC Voltage: V ==

Neutral Fusing: —

Electric Shock Hazard: ⚡

Mounting (Power Supply & Battery Module)



WARNING!

Mount the Power Supply Module and Battery Module **BEFORE** connection. The mounting brackets are only designed to support a Tripp Lite Power Supply Module and a single Battery Module. Do not mount or place any other devices on the mounting brackets. The mounting brackets will not support the additional weight and may fail. Failure to follow these warnings may lead to product damage and/or risk of personal bodily harm. It is the responsibility of the user to determine the fitness of the mounting materials, hardware and procedures before mounting. If the materials, hardware or procedures are not suitable for your application, contact Tripp Lite for assistance.

The included mounting materials are designed to adapt the Mobile Power Retrofit Kit to fit multiple cart configurations. See diagrams on the following pages to locate the mounting procedure that matches your specific cart configuration. The mounting procedures include:

Option 1: Mounting on a Center Pole

Option 2: Mounting on a Bottom Shelf (Using Existing Shelf)

Option 3: Mounting on a Bottom Shelf (Replacing Existing Shelf)

Option 4: Mounting on a 12- or 16-inch Infologix SL-Series Cart

Option 5: Mounting on a CPU Bracket

Option 1: Mounting on a Center Pole

1A Required Hardware: #10-32 x 3/8 Phillips Head Screws (4); #10-32 Star Washers (4). Attach the Power Supply Module to the mounting bracket as shown. Make sure that the Power Supply Module is oriented as shown in the diagram with its outlets facing up.

Required Hardware: #10-32 x 1 Phillips Head Screws (2); #10-32 Fender Washers (2). Attach hardware to the bottom of the mounting bracket. Fully tighten the screws. (NOTE: These screws are designed to protrude downward even when fully tightened, so as to engage the cart's legs in step 1B.)

1B Using one or more assistants, lift the Power Supply Module/mounting bracket and place it around the cart's center pole as shown. (NOTE: Since the mounting bracket is designed to accommodate a wide variety of center pole sizes, attach the screw clamps as described in step 1C.) When lowering the mounting bracket into place, make sure that the screws on the bottom of the bracket engage the cart's legs in order to prevent the retrofit kit from rotating around the cart's center pole. To minimize rotation, make sure the side of the mounting bracket is perpendicular (90°) in relation to one of the cart's legs, as shown in the "Top View" diagram. Lift and readjust if needed.

1C The mounting bracket is designed to accommodate a wide variety of center pole sizes. To secure bracket to center pole, wrap the two included screw clamps around the cart's center pole and through the raised slots on the mounting bracket. Use a screwdriver to fully tighten clamps.

1D Required Hardware: #8-32 x 3/8 Phillips Head Screws w/Washers (6). Attach the Battery Module to the mounting bracket as shown.

1E Required Hardware: 5/16-8 x 5/8 Hex Screws (4); 5/16 Flat Washers (4); 5/16 Lock Washers (4); 5/16 Nuts (4). Using one or more assistants, lift the Battery Module (with its mounting bracket) and attach it to the Power Supply Module (with its mounting bracket) as shown.

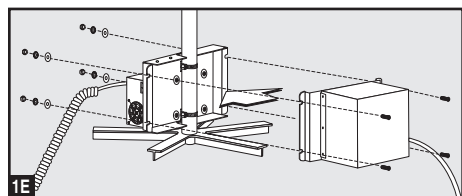
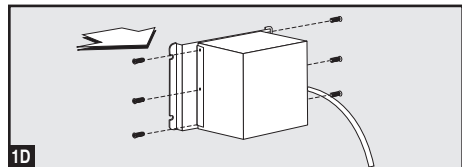
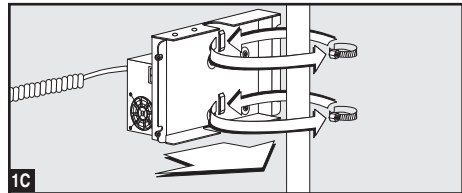
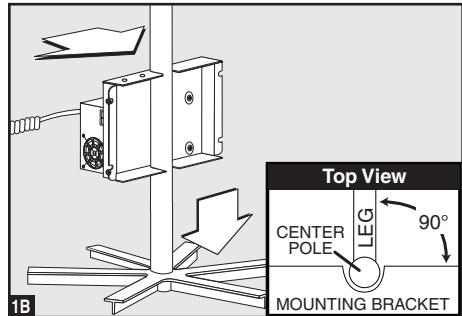
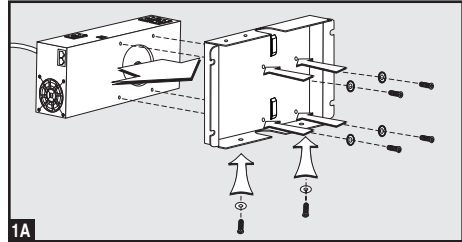

Mounting (Power Supply & Battery Module) continued

Option 2: Mounting on a Bottom Shelf (Using Existing Shelf)

Note: The diagrams below represent a suggested arrangement of the power supply and battery module. Depending on the size of the existing shelf, you can arrange the power supply and battery module any way you desire as long as you don't cover up any outlets, ports, ventilation fans/slots or other features. Secure the power supply and battery module to the shelf in a manner suitable for your specific application.

2A Required Hardware: #10-32 x 3/8 Flat Head Screws; #8 x 3/8 Pan Head Screws w/Washers. For added stability, the Power Supply Module may be secured to the Battery Module as shown.

2B Carefully lift Power Supply Module and Battery Module, and place on the existing shelf.

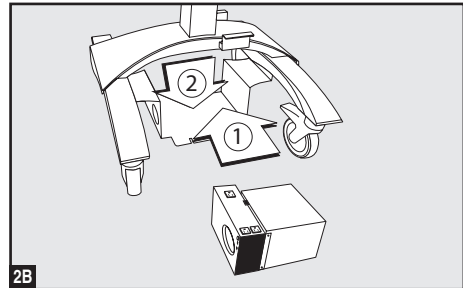
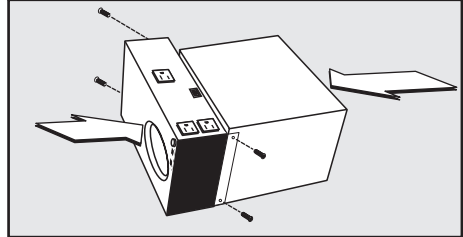
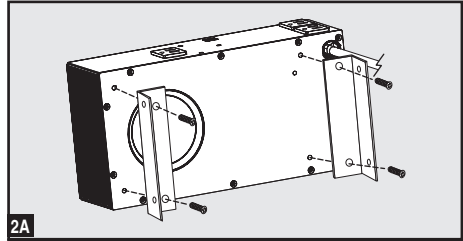

Option 3: Mounting on a Bottom Shelf (Replacing Existing Shelf)

Note: This optional 22 x 17.26-in. replacement shelf is not included with your unit; a Bottom Shelf Mounting Kit (shelf and required hardware) is available separately from Tripp Lite.

- 3A** Lay cart on its side and remove existing shelf from bottom of cart.*

** The existing shelf is not required for mounting or operation of Tripp Lite's Retrofit Kit. However, Tripp Lite's replacement shelf includes holes that will accept the blocks from the existing shelf (if desired).*

- 3B** Required Hardware: #10-32 x 3/8 Pan Head Screws (4); #10 Star Washers (4). Attach the Power Supply Module to replacement mounting shelf as shown. Make sure that the Power Supply Module outlets are facing out and will not be blocked when you mount the Battery Module in step 3E.

NOTE: The mounting tray has identical mounting holes on each side, allowing Power Supply Module and Battery Module to be mounted on either side of the cart.

- 3C** Required Hardware: 5/16-18 x 5/8 Hex Bolts (10); 5/16-18 Nuts (10); 5/16 Flat Washers (10); 5/16 Lock Washers (10). Attach the replacement mounting shelf to the bottom of cart as shown. To securely engage the cart's threaded holes, the included bolts must be installed from the outside in as shown. Access the cart's threaded holes by reaching inside the hollow crossbar that holds the cart's wheels.

- 3D** Required Hardware: #8-32 x 3/8 Phillips Head Screws w/Washers (4). Attach "L" brackets to the sides of the battery module as shown.

- 3E** Required Hardware: #8-32 x 1/2 Phillips Head Screws w/Washers (4); #8-32 Washers (4); #8-32 Nuts (4). Stand cart upright. Attach Battery Module to the replacement mounting shelf as shown.

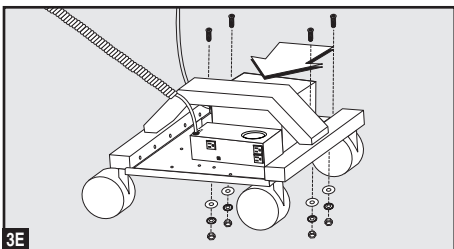
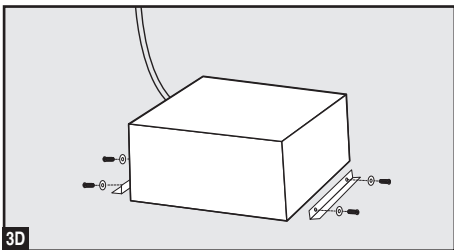
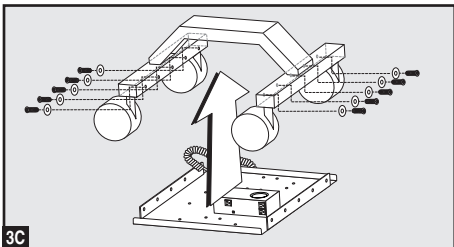
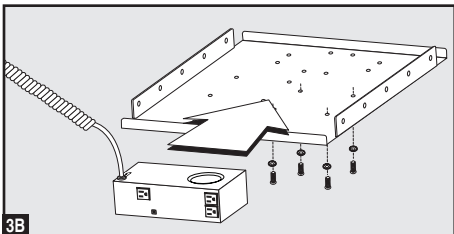
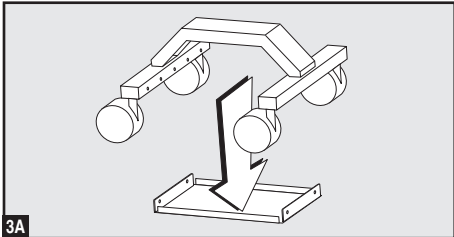

Mounting (Power Supply & Battery Module) continued

Option 4: Mounting on a 12- or 16-inch Infologix SL-Series Cart

- 4A** Required Hardware: #10-32 x 3/8 Flat Head Screws (4); #8 x 3/8 Pan Head Screws w/ Washers (4). Using the brackets provided, bolt the Power Supply Module and Battery Module together, then install the assembly on the included replacement mounting shelf as shown.
- 4B** Required Hardware (12-in. Cart): 1/4-20 x 1/2 Pan Head Screws (8). Required Hardware (16-in. Cart): 1/4-20 x 1/2 Pan Head Screws (8); 1/4-20 Nuts (4). Following the 12- or 16-inch diagram, depending on the cart size, attach the mounting brackets to the vertical sides of the mounting shelf. Mount the assembly to the underside of the cart as shown. Make sure that the cart's wheels have ample clearance.

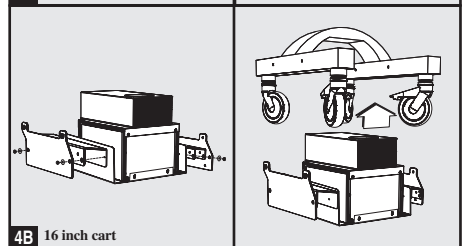
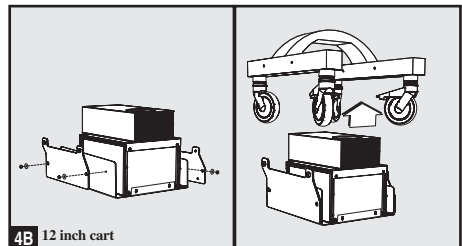
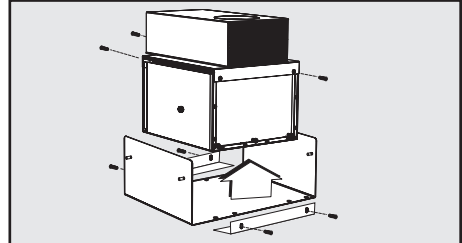
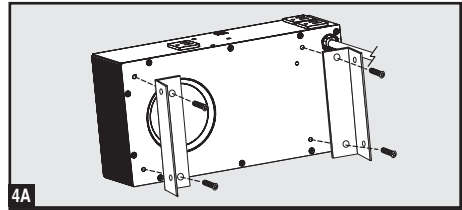

Option 5: Mounting on a CPU Bracket

- 5A** Bolt the Power Supply Module and Battery Module together as shown in step 2A.
- 5B** Slide Power Supply Module/Battery Module into mobile cart's CPU bracket as shown.

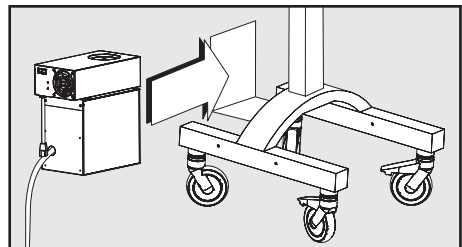

Connection / Start-Up

NOTE!

It is the user's responsibility to ensure that all of the Mobile Power Retrofit Kit's cables and cords are securely stowed after connection where they will not pose a snag or trip hazard. Several cord-management devices are included for this purpose; however the user may need to supply additional devices, depending on their application.

Mount Remote User Interface (RUI) in a convenient location on the cart using user-supplied hardware.

1 Connect the Remote User Interface (RUI) to the Power Supply Module

The Power Supply Module will not operate without the RUI connected. Connect the included grey cord* from the RUI jack labeled "COMM1 GREY" to the Power Supply Module jack labeled "COMM1 GREY". Connect the included black cord* from the RUI jack labeled "COMM2 BLACK" to the Power Supply Module jack labeled "COMM2 BLACK".

** If desired, you can substitute any standard Ethernet cable with RJ45 connectors in place of the included cords.*

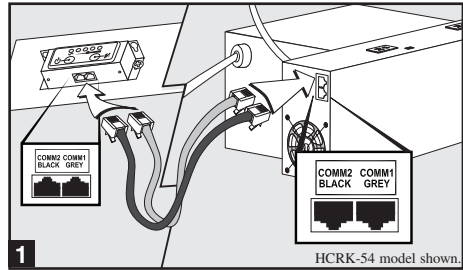

2 Connect the Battery Module to the Power Supply Module

Your Power Supply Module has no internal batteries and must be connected to a Battery Module to operate. Make sure that the Battery Module's cable is fully inserted into the Power Supply Module's connector. Small sparks may result during battery connection; this is normal.

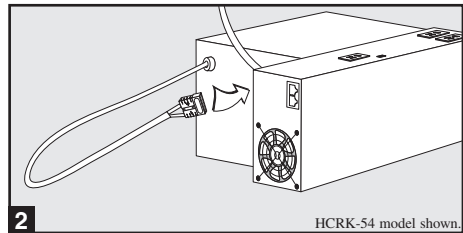

3 Plug In the Power Supply Module

Using the coiled AC power cord, plug the Power Supply Module into a live 120V AC utility wall outlet.

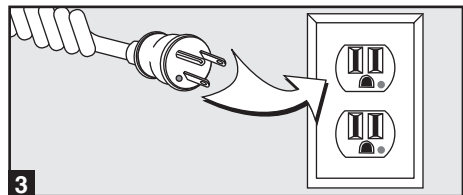

CAUTION!

The Power Supply Module features a hospital-grade plug. If the plug is connected to a wall outlet that is not hospital-grade, the unit may not be properly grounded.

4 Charge the Battery Module

When the Power Supply Module is plugged into a live AC wall outlet, it will automatically charge the Battery Module.



CAUTION!

The Power Supply Module must be plugged into a live AC utility wall outlet for 24 hours after initial installation to fully charge the Battery Module. If the Power Supply Module is plugged in and turned on, your connected equipment will receive utility-supplied AC power (if present); however, your connected equipment may not receive full battery backup when the Power Supply is mobile (disconnected from an AC outlet) until the Battery Module is fully charged.

5 Turn the Power Supply Module's Outlets ON

Press and hold the “Power” button* for one second. The alarm will beep once briefly after one second has passed. Release the button. The “Power” LED* will illuminate to indicate that the Power Supply Module's outlets are ON. The Battery Charge LED Meter* will indicate the approximate charge level of the connected Battery Module.

** Located on the Remote User Interface (RUI).*

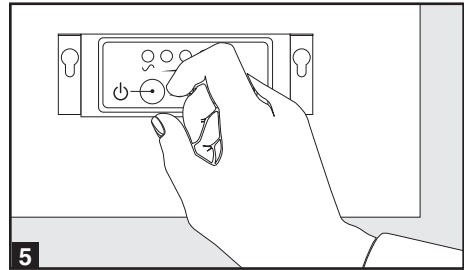

6 Plug Your AC Equipment into the Power Supply Module's Outlets

The Power Supply Module provides filtered, pure sine-wave 120V AC power for a variety of equipment—computers, monitors, diagnostic devices, scanners and more. You will overload the Power Supply Module if the total wattage for all the equipment you connect exceeds 300W (the Power Supply Module's continuous output capacity).*

** To find your equipment's wattage, look on their nameplates. If the equipment is listed in amps, multiply the number of amps by 120 to determine watts. (Example: 1 amp x 120 = 120W).*

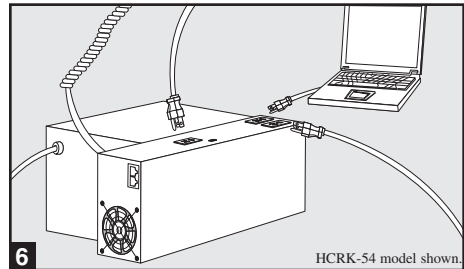

7 OPTIONAL—Install PowerAlert Data-Saving Software

This connection is optional. The Power Supply Module and Battery Module will function properly without this connection. Using the included cable*, connect the Power Supply Module's USB port to the USB port on any laptop or desktop computer mounted on the mobile cart. Insert the included PowerAlert CD and load the version of PowerAlert appropriate for the computer's operating system. Follow the setup and configuration screens for your specific application. PowerAlert documentation is also included on the CD.

** If desired, you can substitute a standard USB cable in place of the included cable.*

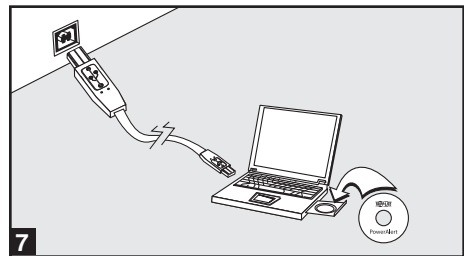

Operation



CAUTION!

The Power Supply will not provide output power to connected equipment in either of the following conditions: Battery Module or RUI disconnected;* Battery Module fully discharged.**

*The user may need to turn on the Power Supply Module manually (using the RUI's "Power" button) after reconnection.

** Battery Modules continuously left in a discharged state will suffer a permanent loss of capacity. Full recharge time is roughly equal to full discharge time.

Mobile Operation (Unplugged / Battery Discharging)

Unplug the Power Supply Module from the AC wall outlet. Ensure that the cord is safely stowed aboard the cart to reduce the risk of damage.

Use connected equipment between charges, depending on battery conditions, environmental conditions and equipment load. Contact Tripp Lite for additional solutions to meet all your runtime needs. As the Battery Module's charge is depleted, the Battery Charge LED Meter will indicate the approximate charge level (see chart).

To turn the Power Supply Module's outlets (and any connected equipment) OFF and stop the battery from discharging, press the "Power" button for one second. The alarm will beep once briefly after one second has passed. Release the button. All LEDs will be OFF.

Charge Level Indicators (Discharging)

Approximate Battery Module Charge Level	Battery Charge LED Meter Display				Low Battery Alarm*
	○	○	○	○	
90 - 100%	Green	Green	Green	Green	OFF
60% - 89%	Green	Green	Green	OFF	OFF
31% - 59%	Yellow	Yellow	OFF	OFF	ON
<= 30%	Flashing Red	OFF	OFF	OFF	ON

* The low battery alarm will beep once per second unless it is silenced by pressing the "Alarm Mute" button. Once the charge level falls below 30% (and shutdown is imminent) the alarm will resume again after one minute. The user should save open files and safely shut down connected equipment immediately. If the cart is unattended and PowerAlert Software is loaded on a computer connected to the Power Supply Module, PowerAlert will automatically save open files prior to automatic shutdown.

Stationary Operation (Plugged In / Battery Charging)

Plug the Power Supply Module into a live AC wall outlet.* The Power Supply Module will deliver AC power to connected equipment while simultaneously charging the Battery Module.

Use connected equipment indefinitely as long as the Power Supply is connected to a live AC outlet. If the utility power fails, due to a blackout or severe brownout, the Power Supply will automatically support connected equipment with AC power from the Battery Module (if adequately charged). When power resumes after a blackout, the Power Supply will automatically resume supplying AC power and recharging the Battery Module.

Charge Level Indicators (Charging)

Approximate Battery Module Charge Level	Battery Charge LED Meter Display			
	○	○	○	○
90 - 100%	Green	Green	Green	Green
60% - 89%	Green	Green	Green	Flashing Green
31% - 59%	Green	Green	OFF	Flashing Green
<= 30%	Green	OFF	OFF	Flashing Green

* Tripp Lite recommends that the Power Supply be plugged into a wall outlet, charging the battery as often as possible. Charging the batteries for brief intervals DOES NOT adversely affect battery performance. However, leaving the batteries fully discharged for long periods of time DOES adversely affect battery performance.

Features

Remote User Interface (RUI)



“Power” Button: This button turns the Power Supply Module’s outlets (and any connected equipment) on and off.

To turn the Power Supply Module’s outlets ON: Press and hold the “Power” button for one second. The alarm will beep once briefly after one second has passed. Release the button. The “Power” LED will illuminate. The “Power” button will turn the outlets on regardless of whether the Power Supply Module is plugged in or not.

To turn the Power Supply Module’s outlets OFF: Press and hold the “Power” button for one second. The alarm will beep once briefly after one second has passed. Release the button. The “Power” LED will turn off.



Alarm Mute Button: This button silences the Power Supply Module’s low battery alarm. To silence the low battery alarm, briefly press and release the Alarm Mute button. The low battery alarm will beep once per second unless it is silenced. Once the charge level falls below 30% (and shutdown is imminent) the alarm will resume again after one minute. Once the charge level falls below 30%, the user should save open files and safely shut down connected equipment immediately. If the cart is unattended and PowerAlert Software is loaded on a computer connected to the Power Supply Module, PowerAlert will automatically save open files prior to automatic shutdown.



“Power” LED: This green LED indicates whether the Power Supply Module’s outlets are ON or OFF.

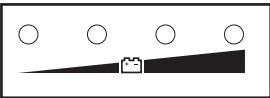

Battery Charge LED Meter: These LEDs will illuminate in several sequences to indicate the approximate charge level of the Battery Module. See “Operation” section for charts illustrating Battery Charge LED Meter Display depending on different charge levels while discharging and charging.



Communications Jacks: Connect the RUI to the Power Supply Module.

Power Supply Module

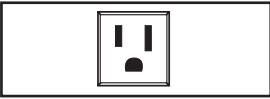

AC Outlets: Provide filtered, pure sine-wave 120V AC power for all equipment—computers, monitors, diagnostic devices, scanners and more.



Coiled AC Input Cord with Hospital-Grade Plug: Connects Power Supply Module to any 120V AC wall outlet.



CAUTION!

The Power Supply Module features a hospital-grade plug. If the plug is connected to a wall outlet that is not hospital-grade, the unit may not be properly grounded.

Power Supply Module continued



USB Port: This port connects the Power Supply Module to any cart-mounted computer (laptop or desktop) with included cable. Use with PowerAlert Data-Saving Software (included on CD) to automatically save open patient data files and safely close applications if the Battery Module is depleted or if utility power is disconnected while the cart is unattended. Consult your PowerAlert manual (included on CD) for more information.



Battery Connectors: Use to connect the Power Supply Module to the Battery Module. Contact Tripp Lite for additional solutions to meet all your runtime needs.



Cooling Fan: Quiet, efficient fan regulates internal temperature and prolongs equipment service life. Fan runs continuously on low or high, depending on temperature levels and load.



Communications Jacks: Connects the Power Supply Module to the Remote User Interface (RUI).

Isolation Transformer (Internal. Not Shown): Ensures full UL 60601-1 compliance by managing current leakage of connected equipment.

Automatic Transfer Switch—ATS (Internal. Not Shown): Works automatically, whether plugged in or mobile. Allows Power Supply Module to simultaneously run connected equipment while recharging the Battery Module.

Advanced, 3-Stage Battery Charger (Internal. Not Shown): Recharges batteries safer and faster than conventional chargers. Faster charging ensures faster cart rotation between shifts.

Battery Module

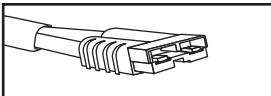

Battery Cable: Use to connect the Battery Module to the Power Supply Module.

Troubleshooting

Problem

Possible Solutions

No AC output power available at outlets.

Turn Unit ON: Turn the Power Supply Module ON using the “Power” Button. See “Connection / Start-Up” section for details.

Check Connections: Check to make sure the Power Supply Module and Battery Module are properly connected. Also, make sure the RUI is properly connected to the Power Supply Module and that the RUI cables are not crossed. The Power Supply Module will not supply AC power without these connections. The user may need to turn on the Power Supply Module manually (using the RUI’s “Power” button) after reconnection. See “Connection / Start-Up” section for details.

Recharge Battery Module: If the Battery Module is fully discharged, the Power Supply Module will be unable to supply output power through its AC outlets. Allow the Battery Module to fully charge. See “Connection / Start-Up” section for details.

Battery Module not recharging, even with AC utility power present.

Check Connections: Check to make sure the Power Supply Module and Battery Module are properly connected. Also, make sure the Power Supply Module’s power cord is plugged into a live AC wall outlet. See “Connection / Start-Up” section for details.

Replace Battery Module: The Battery Module will reliably supply backup power for several years with normal use. When the Battery Module reaches the end of its service life it will supply progressively diminishing capacity. Contact Tripp Lite for additional information.

Low battery alarm sounding.

Check Battery Charge Level LED Meter: Silence the alarm, if desired, with the “Alarm Mute” button. Check LED meter to determine the percentage of charge remaining. (See “Operation” section for charts illustrating Battery Charge LED Meter Display depending on different charge levels while discharging and charging.) When the charge level falls below 20%, the Battery Module is nearly depleted and Power Supply Module shutdown is imminent. The user should save open files and safely shut down connected equipment immediately. If the cart is unattended and PowerAlert Software is loaded on a computer connected to the Power Supply Module, PowerAlert will automatically save open files prior to automatic shutdown.

Storage & Service

Storage

For short term storage (when charging the Battery Module between shifts), see "Operation" section.



CAUTION!

Even after the Power Supply Module is unplugged, its outlets may still deliver current, until it is disconnected from the Battery Module and completely turned OFF (deactivated).

Before storing your Power Supply Module, make sure the Battery Module is fully charged. Next, turn the Power Supply Module completely OFF by following these steps: (1) unplug the Power Supply Module from the wall outlet (all LEDs and outlets should be OFF before you unplug the Power Supply Module); (2) disconnect the Power Supply Module from the Battery Module; (3) press and hold the "Power" button for at least one second to dissipate any hazardous electrical charges that might remain inside the Power Supply Module (the Power Supply Module will click and the alarm may beep briefly).

If you store the Power Supply Module and Battery Module for an extended period of time, recharge the Battery Module once per month. Follow the connection and recharge procedure in the "Connection / Start-Up" section. If you leave the Battery Module discharged for an extended period of time, it will suffer a permanent loss of capacity.

Service

Your Tripp Lite product is covered by the warranty described in this manual. A variety of Extended Warranty and On-Site Service Programs are also available from Tripp Lite. For more information on service, visit www.tripplite.com/support. Before returning your product for service, follow these steps:

1. Review the installation and operation procedures in this manual to insure that the service problem does not originate from a misreading of the instructions.
2. If the problem continues, do not contact or return the product to the dealer. Instead, visit www.tripplite.com/support.
3. If the problem requires service, visit www.tripplite.com/support and click the Product Returns link. From here you can request a Returned Material Authorization (RMA) number, which is required for service. This simple on-line form will ask for your unit's model and serial numbers, along with other general purchaser information. The RMA number, along with shipping instructions will be emailed to you. Any damages (direct, indirect, special or consequential) to the product incurred during shipment to Tripp Lite or an authorized Tripp Lite service center is not covered under warranty. Products shipped to Tripp Lite or an authorized Tripp Lite service center must have transportation charges prepaid. Mark the RMA number on the outside of the package. If the product is within its warranty period, enclose a copy of your sales receipt. Return the product for service using an insured carrier to the address given to you when you request the RMA.

Safety & Regulatory Statements

It is the user's responsibility to verify and ensure that Tripp Lite's Medical-Grade, Mobile Power Retrofit Kit is appropriate for use within their specific application (meeting all safety and regulatory requirements for the application).

Regulatory Compliance Identification Numbers

For the purpose of regulatory compliance certifications and identification, your Tripp Lite product has been assigned a unique series number. The series number can be found on the product nameplate label, along with all required approval markings and information. When requesting compliance information for this product, always refer to the series number. The series number should not be confused with the marking name or model number of the product.

UL CLASSIFICATION FOR MEDICAL EQUIPMENT: Class I, Type B, Ordinary Equipment, Continuous Operation.

UL 60601-1 APPROVAL: The Power Supply Module incorporates a Faraday-shielded isolation transformer that reduces the cumulative leakage current of all connected equipment to below 300 microamps.

UL 1778 APPROVAL: The Power Supply Module described in this manual is UL 1778 listed. It meets strict requirements for UPS protection. It provides battery backup during blackouts, switching between utility power and battery backup power in 2-4 milliseconds.

FCC Notice, Class A

This device complies with part 15 of the FCC Rules. Operation is subject to the following two conditions: (1) This device may not cause harmful interference, and (2) this device must accept any interference received, including interference that may cause undesired operation.

Note: This equipment has been tested and found to comply with the limits for a Class A digital device, pursuant to part 15 of the FCC Rules. These limits are designed to provide reasonable protection against harmful interference when the equipment is operated in a commercial environment. This equipment generates, uses, and can radiate radio frequency energy and, if not installed and used in accordance with the instruction manual, may cause harmful interference to radio communications. Operation of this equipment in a residential area is likely to cause harmful interference in which case the user will be required to correct the interference at his own expense. The user must use shielded cables and connectors with this equipment. Any changes or modifications to this equipment not expressly approved by Tripp Lite could void the user's authority to operate this equipment.

Warranty & Warranty Registration

Limited Warranty

Tripp Lite warrants its Power Supply Module to be free from defects in materials and workmanship for a period of 2 years from the date of purchase by end user. Tripp Lite warrants its Battery Module to be free from defects in materials and workmanship for a period of 6 months from the date of purchase by end user. Tripp Lite's obligation under this warranty is limited to repairing or replacing (at its sole option) any such defective products. To obtain service under this warranty you must obtain a Returned Material Authorization (RMA) number from Tripp Lite or an authorized Tripp Lite service center. Products must be returned to Tripp Lite or an authorized Tripp Lite service center with transportation charges prepaid and must be accompanied by a brief description of the problem encountered and proof of date and place of purchase. This warranty does not apply to equipment which has been damaged by accident, negligence or misapplication or has been altered or modified in any way, including opening of the unit's casing for any reason. This warranty applies only to the original purchaser who must have properly registered the product within 10 days of purchase.

EXCEPT AS PROVIDED HEREIN, TRIPP LITE MAKES NO WARRANTIES, EXPRESS OR IMPLIED, INCLUDING WARRANTIES OF MERCHANTABILITY AND FITNESS FOR A PARTICULAR PURPOSE. Some states do not permit limitation or exclusion of implied warranties; therefore, the aforesaid limitation(s) or exclusion(s) may not apply to the purchaser. EXCEPT AS PROVIDED ABOVE, IN NO EVENT WILL TRIPP LITE BE LIABLE FOR DIRECT, INDIRECT, SPECIAL, INCIDENTAL OR CONSEQUENTIAL DAMAGES ARISING OUT OF THE USE OF THIS PRODUCT, EVEN IF ADVISED OF THE POSSIBILITY OF SUCH DAMAGE. Specifically, Tripp Lite is not liable for any costs, such as lost profits or revenue, loss of equipment, loss of use of equipment, loss of software, loss of data, costs of substitutes, claims by third parties, or otherwise.

Warranty Registration

Visit www.tripplite.com/warranty today to register the warranty for your new Tripp Lite product. You'll be automatically entered into a drawing for a chance to win a FREE Tripp Lite product!

* No purchase necessary. Void where prohibited. Some restrictions apply. See website for details.

Tripp Lite has a policy of continuous improvement. Specifications are subject to change without notice.



1111 W. 35th Street, Chicago, IL 60609 USA
www.tripplite.com/support