



M170 Flat Panel Display Touch Monitor User Guide

3M Touch Systems, Inc.

Read and understand all safety information
contained in this document before using this product.

The information in this document is subject to change without notice. No part of this document may be reproduced or transmitted in any form or by any means, electronic or mechanical, for any purpose, without the express written permission of 3M Touch Systems, Inc. 3M may have patents or pending patent applications, trademarks, copyrights, or other intellectual property rights covering subject matter in this document. The furnishing of this document does not give you license to these patents, trademarks, copyrights, or other intellectual property except as expressly provided in any written license agreement from 3M Touch Systems, Inc.

The information provided in this document is intended as a guide only. For the latest detailed engineering specifications, please contact your 3M Touch Systems, Inc. Application Engineer. 3M Touch Systems, Inc., Inc is committed to continually improving product designs, as a result, product specifications may be subject to change without notification.

"RoHS Directive compliant" means that the product or part does not contain any of the following substances in excess of the following maximum concentration values in any homogeneous material, unless the substance is in an application that is exempt under RoHS: (a) 0.1% (by weight) for lead, mercury, hexavalent chromium, polybrominated biphenyls or polybrominated diphenyl ethers; or (b) 0.01% (by weight) for cadmium. Unless otherwise stated by 3M in writing, this information represents 3M's knowledge and belief based on information provided by third party suppliers to 3M.

NOTICE: Given the variety of factors that can affect the use and performance of a 3M Touch Systems, Inc. Product (the "Product"), including that solid state equipment has operation characteristics different from electromechanical equipment, some of which factors are uniquely within User's knowledge and control, it is essential that User evaluate the 3M Touch Systems, Inc. Product and software to determine whether it is suitable for User's particular purpose and suitable for User's method of application. 3M Touch Systems, Inc. statements, engineering/technical information, and recommendations are provided for User's convenience, but their accuracy or completeness is not warranted. 3M Touch Systems, Inc. products and software are not specifically designed for use in medical devices as defined by United States federal law. 3M Touch Systems, Inc. products and software should not be used in such applications without 3M Touch Systems, Inc. express written consent. User should contact its sales representative if User's opportunity involves a medical device application.

IMPORTANT NOTICE TO PURCHASER: Specifications are subject to change without notice. These 3M Touch Systems, Inc. Products and software are warranted to meet their published specifications from the date of shipment and for the period stated in the specification. **3M Touch Systems, Inc. makes no additional warranties, express or implied, including but not limited to any implied warranties of merchantability or fitness for a particular purpose.** User is responsible for determining whether the 3M Touch Systems, Inc. Products and software are fit for User's particular purpose and suitable for its method of production, including intellectual property liability for User's application. If the Product, software or software media is proven not to have met 3M Touch Systems, Inc. warranty, then 3M Touch Systems, Inc. sole obligation and User's and Purchaser's **exclusive remedy**, will be, at 3M Touch Systems, Inc. option, to repair or replace that Product quantity or software media or to refund its purchase price. 3M Touch Systems, Inc. has no obligation under 3M Touch Systems, Inc. warranty for any Product, software or software media that has been modified or damaged through misuse, accident, neglect, or subsequent manufacturing operations or assemblies by anyone other than 3M Touch Systems, Inc. **3M Touch Systems, Inc. shall not be liable in any action against it in any way related to the Products or software for any loss or damages, whether non-specified direct, indirect, special, incidental or consequential (including downtime, loss of profits or goodwill) regardless of the legal theory asserted.**

© 2003--2006 3M All rights reserved.
Printed in the United States of America.

Document Title: *M170 FPD Touch Monitor User Guide*
Document Number: 19-268, Version 03

MicroTouch, the MicroTouch logo, and ClearTek are either registered trademarks or trademarks of 3M in the United States and/or other countries.

Windows and/or other Microsoft products referenced herein are either registered trademarks or trademarks of Microsoft Corporation in the U.S. and/or other countries.

Contents

Overview

Important Safety Information	5
Intended Use	5
Explanation of Symbols	7
Service and Repair Indicators	7
3M Touch Systems Support Services	8
3M Touch Systems Worldwide Offices	8

Chapter 1

Introduction to Flat Panel Displays

Native Video Resolution on a Flat Panel Display	10
Options for Using Other Video Resolutions	10

Chapter 2

Setting Up Your M170 FPD Monitor¹¹

System Requirements	11
Unpacking Your Touch Monitor	12
Alternative Mounting Options	12
M170 Wall-Mount Locking Mechanism	15
Countertop Base Mounting Option	16
Access to the Video Controls	16
Adjusting the Viewing Angle	16
Installing the Video Card and Video Driver	17
Supported Video Display Modes and Refresh Rates	17
Configuring the Display Settings	18
Using the Standard Controls for the Video Card	18
Multimedia Features	19
Optional Card Reader Bracket	19
Supported Magnetic Stripe Readers	19
Connecting the Touch Monitor	20
Testing the M170 FPD	22
Installing Touch Software	22
Calibrating the Touch Screen	23

Chapter 3

Video Display Options

Adjusting the M170 Video Display	25
Lock Out Feature	28

Chapter 4**Maintenance and Troubleshooting**

Maintaining Your Touch Monitor	29
Touch Screen Care and Cleaning	29
Monitor Installation Problems	30
Troubleshooting the Touch Screen.....	31
Power Management	31
M170 Regulatory Agency Approvals.....	31
FCC Warning.....	32
CE Conformity for Europe.....	32

Overview

Welcome to the world of 3M Touch Systems, Inc. — a world where using a computer is as simple as touching the screen. This guide describes how to set up your M170 Flat Panel Display (FPD) touch monitor.

This document assumes you have basic computer skills. You should know how to use the mouse and keyboard, choose commands from menus, open and run application programs, and save files.

3M Touch Systems, Inc. is committed to being a premier supplier in touch systems throughout the world. As a 3M Touch Systems, Inc. customer, you are aware that we have strong internal programs that meet or exceed environmental regulations of our customers and the regions in which we conduct business.

As such, our approach to the European Union Directives 2002/96/EC (WEEE) and 2002/95/EC (RoHS) (the directives) is being addressed in the same rigorous manner. To ensure compliance with the directives, we are pleased to provide this RoHS compliant product.



Important Safety Information

Read and understand all safety information before using this product. Follow all instructions marked on the product and described in this document. Pay close attention to the following installation warnings and safety precautions.

Intended Use

The M170 flat panel display (FPD) touch monitor was designed for touch input and tested to replace an existing monitor. These monitors are intended for indoor use only and are not designed for use in hazardous locations.

Explanation of Signal Word Consequences

-  **DANGER:** Indicates a potentially hazardous situation, which, if not avoided, will result in death or serious injury and/or property damage.
-  **WARNING:** Indicates a potentially hazardous situation, which, if not avoided, could result in death or serious injury and/or property damage.
-  **CAUTION:** Indicates a potentially hazardous situation, which, if not avoided, may result in minor or moderate injury and/or property damage.
- CAUTION:** Indicates a potentially hazardous situation, which, if not avoided, may result in property damage.

⚠ DANGER

To avoid the risk of fire and/or explosion which will result in serious injury or death:
Do not install or use this product in a hazardous location.

⚠ WARNING

To avoid the risk of fire which could result in serious injury or death:

Do not remove the cover or back of the monitor.

To avoid the risk of electric shock which could result in serious injury or death:

- This device must be operated with the original power supply, part number: HJC, HASU05F.
- Do not use a damaged power supply.
- Do not use a power cord that is frayed or otherwise damaged.

⚠ CAUTION

To avoid the risk of electric shock which may result in minor or moderate injury:

- The socket-outlet should be installed near the equipment and should be easily accessible.
- Use a power cable that is properly grounded. Always use the appropriate AC cord certified for the individual country. Some examples are listed below:
 - USA UL
 - Switzerland SEV
 - Canada CSA
 - Britain BASE/BS
 - Germany VDE
 - Japan Electric Appliance Control Act
- Do not service the Flat Panel Display.
 - There are no user serviceable parts inside.
 - Refer all servicing to qualified service personnel.
 - The backlight inverter output is at high voltage.
- Do not use non-conforming replacement parts.
- Do not place wet or damp objects on the monitor.
- Do not expose the monitor to rain or other sources of water, steam, or moisture.
- Do not place foreign objects on the monitor or its cables.
- Do not remove the cover or back of the monitor.

To avoid the risk of minor or moderate personal injury or damage to the monitor:

- Never wall-mount the monitor without the locking mechanism in place.
- Use an anchoring system appropriate for the weight of the product.
- Consult a construction professional before attempting to hang the unit on the wall.

To avoid the risk of glass breakage which may result in minor or moderate injury:

- Handle the monitor with care to avoid breaking the touch screen sensor. The display contains glass parts. Dropping the display may cause the glass parts to break.
- Do not place foreign objects on the monitor.

To avoid the potentially hazardous situations associated with the use of isopropyl alcohol which may result in minor or moderate injury or property damage:

- Follow all instructions and recommendations in the manufacturer's Material Safety Data Sheet and product label.

To avoid possible environmental contamination which may result in minor or moderate injury:

- Dispose of the flat panel display according to applicable governmental regulations.

Explanation of Symbols

 Attention: Read accompanying documentation

Important Notes:

- Plug power cord into appropriate power source.
 - Plug power cord into a grounded receptacle.
 - When unplugging power supply cord, pull on plug not cord.
 - Do not connect or disconnect this product during an electrical storm.
 - Install the display in a well-ventilated area. Always maintain adequate ventilation to protect the display from overheating and to ensure reliable and continued operation.
 - Do not expose this display to heat. Passive heat may cause damage to the case and other parts.
 - Do not install this display in areas where extreme vibrations may be generated. For example, nearby manufacturing equipment may produce strong vibrations. The vibrations may cause the display to exhibit picture discoloration or poor video quality.
 - Product weight varies from 18 to 24 pounds depending on the packaging, use caution when lifting.
 - Ensure that metal does not contact the touch screen.
 - To avoid ergonomic concerns:
Do not install the monitor in a manner or location with awkward accessibility.
Extended use may result in muscle, tendon, or fixed posture strains. It is recommended you take periodic breaks from continuous use.
-

Service and Repair Indicators

Do not attempt to service this unit yourself. Removing the display cover may expose you to dangerous voltage or other risks and will void the warranty.

 WARNING
--

<p>To avoid the risk of fire which could result in serious injury or death: Do not remove the cover or back of the monitor.</p>
--

 CAUTION
--

<p>To avoid the risk of electric shock which may result in minor or moderate injury:</p> <ul style="list-style-type: none"> • Do not service the monitor. • There are no user serviceable parts inside. • Refer all servicing to qualified service personnel. • Do not remove the cover or back of the monitor.
--

Unplug the display from the power outlet and refer servicing to qualified service personnel in the event that:

- Liquid is spilled into the product or the product is exposed to rain or water.
- The product does not operate properly when operating instructions are followed.
- The product has been dropped or the case has been damaged.
- The product shows a distinct change in performance, indicating a need for service.
- The power cable or plug is damaged or frayed.

3M Touch Systems Support Services

3M Touch Systems provides extensive support services through our website and technical support organization. Visit the 3M Touch Systems website at <http://www.3mtouch.com/>, where you can download touch screen software and drivers, obtain regularly updated technical documentation on 3M Touch Systems products, and learn more about our company.

Whenever you contact Technical Support, please provide the following information:

- Part number and serial number from your monitor
- Current driver version
- Operating system used
- Information on additional peripherals

Technical Support is available Monday through Friday 8 a.m. to 8 p.m. US Eastern Standard Time – 9 a.m. to 5 p.m. throughout Europe.

You can contact 3M Touch Systems Technical Support (US only -- Eastern Standard Time) by calling the hot line, sending an email, or sending a fax.

- Technical Support Hot Line: 978-659-9200
- Technical Support Fax: 978-659-9400
- Toll Free: 1-866-407-6666 (Option 3)
- Email: US-TS-techsupport@mmm.com

3M Touch Systems Worldwide Offices

All offices can be reached through the website: <http://www.3Mtouch.com/>.

CHAPTER 1

Introduction to Flat Panel Displays

The 3M Touch Systems product line of Flat Panel Display (FPD) touch monitors offers the M170 monitor for desktop and countertop applications with built-in multimedia options.

The monitor is available with 3M Touch System's ClearTek® capacitive touch screen. Capacitive is the touch screen of choice for public access applications requiring high levels of durability and reliable performance 24 hours a day, 7 days a week.

Figure 1. The M170 Monitor

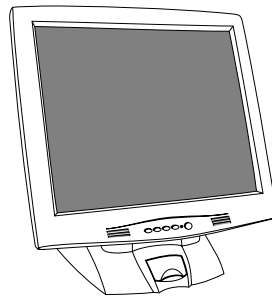

The new M170 monitor features an innovative design adjustable to approximately 90° off the vertical to accommodate different counter and user heights, a positive locking mechanism, a touch screen interface, several mounting options, and built-in cable management.

The M170 monitor also features a space saving design, high resolution, low radiation, and low power consumption. These qualities make the M170 FPD touch monitor ideal for applications that require superior color, resolution, and clarity.

The M170 FPD is a 17" diagonal screen size using active-matrix thin-film transistor (AM-TFT) liquid crystal display technology. The M170 monitor supports a full-screen resolution of 1280 x 1024.

Note: The M170 FPD has a power LED as well as four buttons for using the on-screen menu and adjusting the video display. Refer to Chapter 3 for more information on these controls.

Native Video Resolution on a Flat Panel Display

Flat panel displays, unlike CRTs, are optimized to run at one resolution. A flat panel display has discrete points that determine the exact location of a pixel. Each flat panel display has an exact number of pixels associated with it. There is a one-to-one mapping between the number of pixels and the video resolution.

A flat panel display should be used at the resolution dictated by the number of pixels on the panel for optimum performance. For example, the M170 monitor has 1280 pixels across the screen and 1024 lines of pixels down the screen and can accurately display this resolution at full screen.

Options for Using Other Video Resolutions

The M170 monitor supports all standard resolutions up to their respective native resolution for monitor setup. Refer to Table 1 for additional details. Many video cards initially display a screen image at the SVGA or VGA resolution. By supporting these resolutions, the monitor can display the desktop controls that let you change to the optimal resolution of 1280 x 1024.

CHAPTER 2

Setting Up Your M170 FPD Monitor

This chapter describes how to set up and integrate your 3M Touch Systems M170 FPD monitor into a touch application. You need to complete the following tasks:

- Unpack the components
- Connect the video, touch screen, and power cables to your computer
- Power on the monitor and test your setup
- Install the touch screen software
- Calibrate the touch screen

System Requirements

The M170 flat panel touch monitor requires a personal computer (PC). This touch monitor will not work with Apple Macintosh computers.

The requirements for your PC are as follows:

- Your PC must have an available RS-232 serial communication (COM) port or USB port. You connect the touch screen to this port.
- Your PC must have a video card and video driver already installed for the monitor. If you need to install a video card or a video driver, refer to your computer documentation for instructions.
- Your PC must have a unique interrupt request (IRQ) available to the touch screen COM port. The touch screen cannot share an IRQ with another device.

When choosing your workspace, select a sturdy, level surface. Also, make sure you can easily access the back of the touch monitor and the computer. Easy access helps ensure a smooth setup of the touch monitor.

Note: Before setting up your M170 FPD, refer to the Important Safety Information section at the beginning of this document.

Unpacking Your Touch Monitor

Carefully unpack the carton and inspect the contents. Your M170 monitor comes with most of these cables already connected as well as a touch software CD.



**DVI-I to 15-pin video cable
or DVI to DVI cable if applicable**



**9-pin RS-232 serial communication
cable (if applicable)**



**AC/DC power supply
(12V DC output)**



AC power cable



USB Cable (if applicable)



Multimedia audio cables

Alternative Mounting Options

The unit has a 100 mm VESA mounting pattern on the back to allow for different mounting capabilities. Follow the manufacturer's instructions included with the mounting device to properly attach your monitor.

In order to arm-mount the M170 FPD, you will need to remove the monitor head from the stand. Begin by removing the cable management covers.

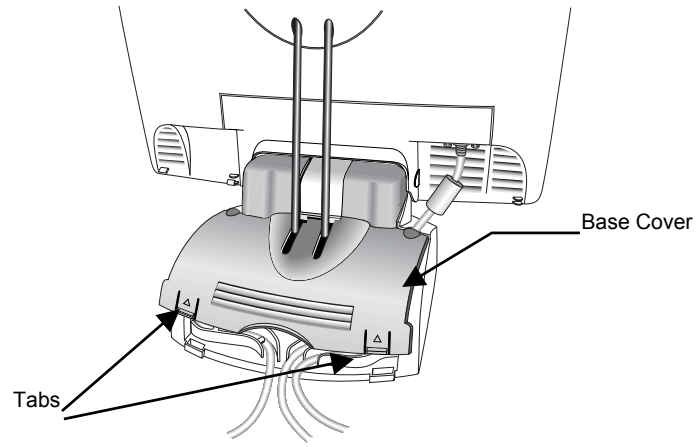
Figure 2. Removing the Base Cover

1. Make sure the monitor is in its full upright position.
2. Push in and lift up on each of the two tabs located on the left and right sides of the base cover. This action will release the base cover.
3. Slide the cover back towards you to remove.

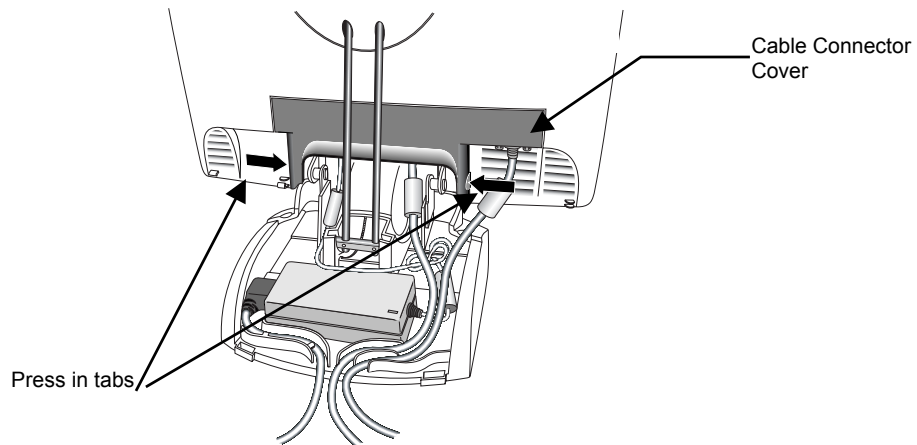
Figure 3. Releasing the Cable Connector Cover

4. Push in on the cable connector tabs as shown above to release from LCD back. Gently pull down to release tabs.

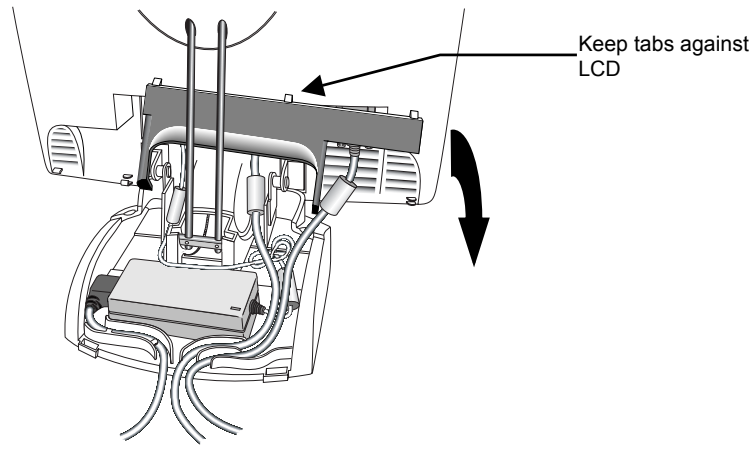
Figure 4. Removing the Cable Connector Cover

5. Lift this cover slightly so that the tabs are up against the rear of the LCD to keep them from catching on the cables below. Tilt the cover down as you slide the cover out from behind the support rods.

Figure 5. Uncovered Cable Connections

Figure 6. Disassembling the LCD from Its Base for Arm Mounting

Step 1 – Unlock front mechanism and disconnect all cables from the LCD.

Step 2 -- With the unit laying face down safely and securely on a nonabrasive surface, remove the two screws connecting the name plate and support rods to the LCD. Lift the support rods out of the base and set aside.

Step 3 -- Then remove the four screws holding the hinge in place and gently remove the base.

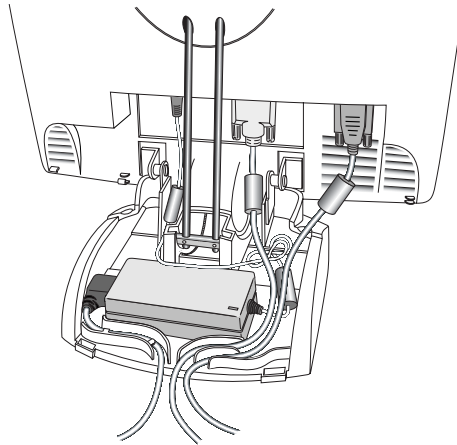
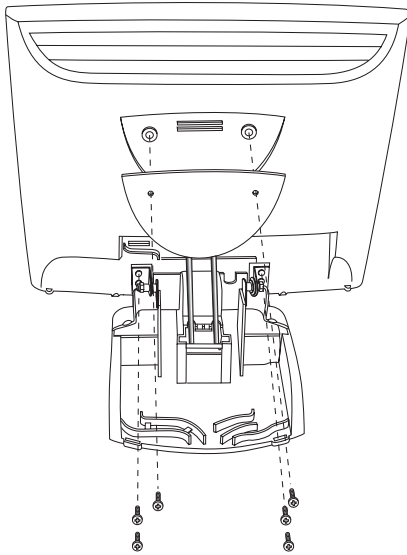
M170 Wall-Mount Locking Mechanism

⚠ CAUTION

To avoid the risk of minor or moderate personal injury or damage to the monitor:

- Never wall-mount the monitor without the locking mechanism in place.
- Use an anchoring system appropriate for the weight of the product.
- Consult a construction professional before attempting to hang the unit on the wall.

To lock the M170 in place for wall mounting, use the locking mechanism included in a separate bag with your monitor. Position the monitor to 90° flat and lock the front latch in place. As an extra measure, insert the U-shaped metal retention clip into the holes in the base as indicated in the drawing below. Tighten the screw in place and your monitor is ready to hang securely on the wall.

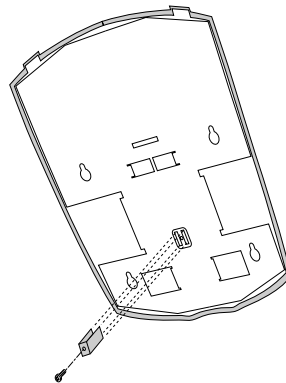
Figure 7. Wall-Mount Locking Mechanism

Countertop Base Mounting Option

Keyhole slots in the bottom of the base plate enable you to secure the unit to a desktop or countertop. Use standard screws in the desktop or countertop and then slide the base plate on for a secure fit.

Note: A full size template has been included in the back of this manual for your convenience. Simply tear out the template and drill directly through the holes indicated to secure your monitor to any surface.

Access to the Video Controls

The controls for adjusting the video display are located on the front of the M170 FPD monitor. These buttons let you display the on-screen menu which enables you to adjust the phase, image position, and contrast, as well as hot keys for volume, auto adjust and brightness. Make sure you have unobstructed access to the video controls once the M170 monitor is installed. Refer to Chapter 3 for more information on these controls.

Adjusting the Viewing Angle

The base and support rods were designed with touch stability in mind. This innovative design keeps the monitor face stable during touch. The unit can be adjusted to any locked position from -5 up to 90 degrees from vertical. This allows for users of different heights to view the monitor at the angle that best suits them with no degradation in touch stability.

Always maintain adequate ventilation to protect the display from overheating and to ensure reliable and continued operation.

Figure 8. Adjusting the Viewing Angle

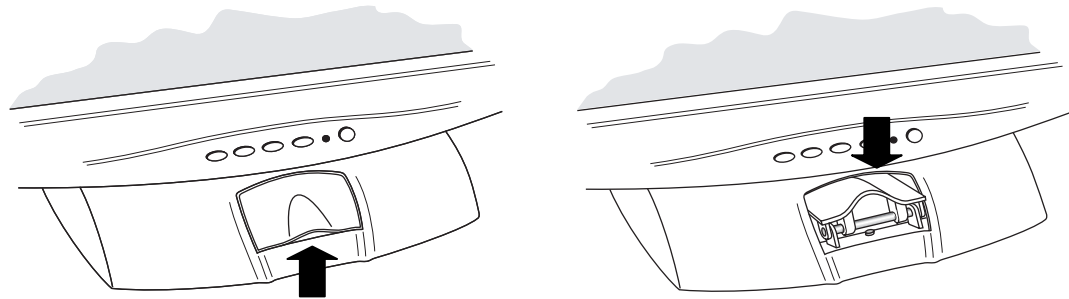

Lift up latch to release lock and raise or lower display to suit your needs.

Push down latch to engage lock and stabilize display position.

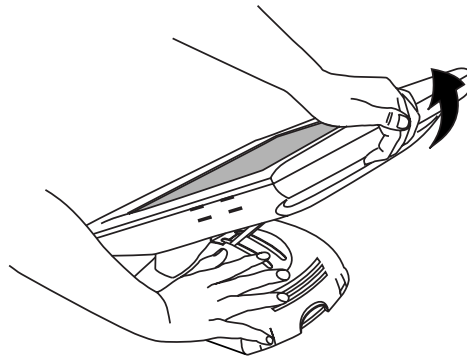

Lift up on the latch to release lock. Adjust the M170 FPD by pushing or pulling on the top front of the monitor until the screen is at the best viewing angle for you. Then push down on latch to engage locking mechanism and stabilize display position.

Installing the Video Card and Video Driver

Before you can connect your touch monitor, make sure your computer has a video card and driver already installed for the monitor. The video driver is supplied by the video card manufacturer and may be found on the disks that came with your computer. If you need information on installing a video card or video driver, refer to your computer documentation for instructions.

Supported Video Display Modes and Refresh Rates

Your video card should support one of the display modes specified in Table 1. If you select an unsupported video mode, the monitor may stop working or display unsatisfactory picture quality.

Table 1. Applicable Display Mode and Refresh Rate

Display Mode	Refresh Rate
DOS	720 x 400 at 70Hz
VGA	640 x 480 at 60Hz
	640 x 480 at 72Hz
	640 x 480 at 75Hz
SVGA	800 x 600 at 56Hz
	800 x 600 at 60Hz
	800 x 600 at 72Hz
	800 x 600 at 75Hz
XGA	1024 x 768 at 60Hz
	1024 x 768 at 70Hz
	1024 x 768 at 75Hz
SXGA	1152 x 864 at 75Hz
	1280 x 1024 at 60Hz

Configuring the Display Settings

After you connect your M170 FPD and turn on your computer, you may need to configure one or more of these display settings. The ideal settings for this monitor are as follows:

- Display mode (also called desktop area or video resolution) 1280 x 1024
- Refresh rate (also called vertical scan rate or vertical sync) 60 Hz
- Color depth (also called color palette or number of colors) at least 16-bit (high color)

Using the Standard Controls for the Video Card

In addition to the standard controls on the monitor, each video card has several controls that let you adjust the display settings. The software and driver for each video card is unique. In most cases, you adjust these settings by using a program or utility provided by the manufacturer of the video card.

For example, you can use the Windows Display Properties control panel to adjust the desktop area (resolution), color depth, and refresh rate. Whenever you change these settings or calibrate the touch screen, the image size, position, or shape may change. This behavior is normal. You can readjust the image using the monitor controls described in Chapter 3 of this guide.

For more information on adjusting the desktop area (resolution), color depth, or refresh rate, refer to your video card documentation.

Multimedia Features

The M170 FPD monitor comes with speakers built into the display bezel. The multimedia cable can be connected to the rear of the monitor for input.

Figure 9. Multimedia Cable



Optional Card Reader Bracket

The M170 FPD monitor is available with an optional card reader bracket (and (2) M3 screws) that supports IDTech and MagTech brand electronic card readers. The black version is part number 5013923 and the beige version is 5103924. The M170 has been designed with slots on either side of the bezel to accommodate this card reader bracket. Simply slide the bracket into the appropriate holes and pull down slightly to lock in place. Refer to the illustration below for wiring suggestions. Note that 3M Touch Systems does not supply the card readers.

Figure 10. Card Reader Mounting and Cable Management

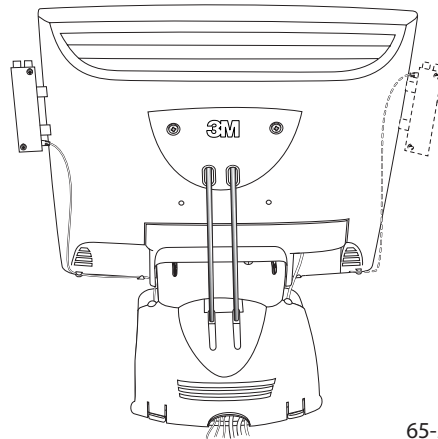

Supported Magnetic Stripe Readers

At the time of publication, the following “mini” magnetic card readers have been tested to fit the 3M Touch Systems optional card reader bracket. Consult your card reader sales representative for model numbers not listed here.

Table 2. Supported Mag Stripe Card Readers

ID Tech®		MagTek®
all MiniMag™ readers		all "mini" sized readers
IDT 3331-02U	IDT 3321-33	2180201
IDT 3331-12U	IDT 3321-33PP	2180202
IDT 3331-23U	IDT 3331-02	2180203
IDT 3331-33U	IDT 3331-12	2180204
IDT 3321-02	IDT 3331-23	2180205
IDT 3321-02PP	IDT 3331-33	2180206
IDT 3321-12	IDT3301-02	21040103
IDT 3321-12PP	IDT3301-12	21040104
IDT 3321-23	IDT3301-23	
IDT 3321-23PP	IDT3301-33	

Connecting the Touch Monitor

⚠ CAUTION

You are cautioned that any change or modification to the equipment not expressly approved by the party responsible for compliance could void your authority to operate such equipment.

The M170 comes with the cables already connected (with the exception of the audio cable), however, there may be times when you need to reconnect these cables for some reason. To connect the M170 FPD monitor:

1. Turn off your computer. You should always turn off the computer before connecting or disconnecting any device.

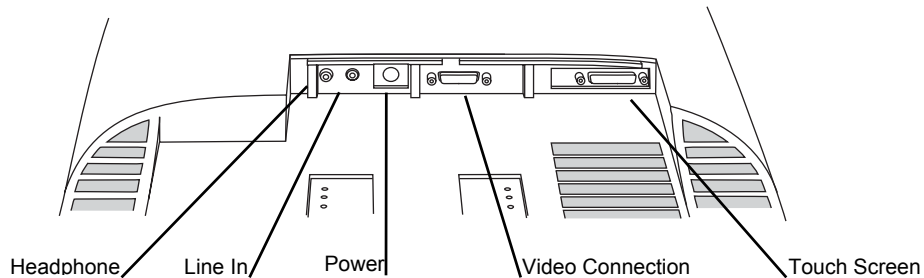
Figure 11. Identifying Your Monitor Connections

2. Connect one end of the video cable to the video connector on the FPD. Connect the other end to the video card in your computer.
3. Connect one end of the touch screen cable (either serial or USB) to the FPD. Connect the other end to an available port on the back of your computer. If you are using a USB connection, make sure you have installed the Touch Software drivers before connecting the touch screen cable.

4. Plug the AC/DC power supply into the M170 FPD. Be sure to use the power supply included with the monitor.

⚠ WARNING

To avoid the risk of electric shock which could result in serious injury or death:
This device must be operated with the original power supply, part number: HJC, HASU05F.

⚠ CAUTION

To avoid the risk of electric shock which may result in minor or moderate injury:

- The socket-outlet should be installed near the equipment and should be easily accessible.
- Use a power cable that is properly grounded. Always use the appropriate AC cord certified for the individual country. Some examples are listed below:

USA	UL
Switzerland	SEV
Canada	CSA
Britain	BASE/BS
Germany	VDE
Japan	Electric Appliance Control Act

5. Connect the power cable to the AC/DC supply. Connect the other end to the appropriate AC outlet.

Figure 12. Connecting the M170 Cables to your Computer

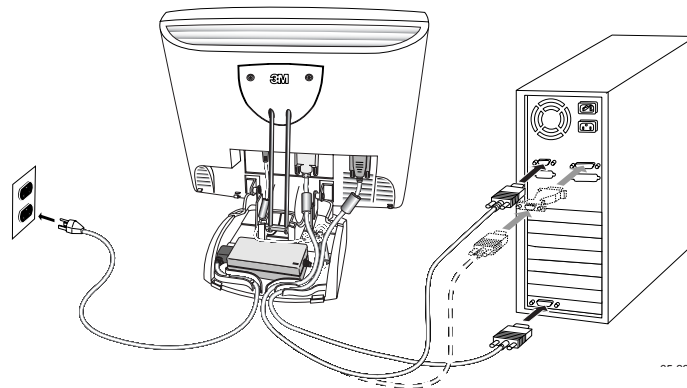

You should be sure all cable connections are secure -- tighten all cable screws. Shaking and vibration may dislodge cables that are improperly connected.

Route all wiring and cabling away from heat sources and sharp metal edges to avoid damage. Also, keep the touch screen cable away from sources of electromagnetic and radio frequency interference.

⚠ WARNING

To avoid the risk of electric shock which could result in serious injury or death:

- Do not use a damaged power supply.
- Do not use a power cord that is frayed or otherwise damaged.

Testing the M170 FPD

Note: The M170 FPD has a power status LED located on the front of the bezel.

After connection, turn on the power switch located on the front bezel. Before you test your touch monitor, make sure all cables are connected properly and routed through the cable management system. Be sure to tighten all cable screws.

To test that the monitor is working properly:

1. Turn on your computer.
2. Make sure the video image is displayed. If it is not, turn on your monitor. Ensure the LED is green – orange indicates power but no signal.
3. Make sure the video image is centered within the screen area. Use the monitor controls to adjust the image, if necessary. Perform an Auto Config first, then if you wish you can adjust the horizontal and vertical position, contrast, and brightness to better suit your video card and your personal preference. Refer to Chapter 3 for more information on using the on-screen menu to adjust the video display.

Installing Touch Software

Touch Software includes the touch screen driver and control panel that enables your touch screen to work with your computer. When you install the CD included with your monitor, Touch Software will automatically load the correct driver for your system. 3M Touch Systems currently supports touch screen drivers for the following PC operating systems:

- Windows XP (serial and USB)
- Windows 2000 (serial and USB)
- Windows NT 4.0 (serial only)
- Windows 9x (serial and USB (Windows 98 only))
- Windows Me (serial and USB)

These drivers and relevant technical documentation, can be found on the latest 3M Touch Solutions CD (31197) and are available for download from our website at www.3Mtouch.com. After the software is installed, restart your computer to load and activate the touch screen driver. To complete the setup of your touch monitor, make sure you calibrate the touch screen.

Calibrating the Touch Screen

After you connect your touch monitor and install Touch Software, you must calibrate the touch screen. *Calibration* serves two purposes:

- Sets the active area of the touch screen
- Aligns the touch screen's active area to the underlying video

To calibrate the touch screen, open the touch screen control panel and select Calibrate. Follow the directions displayed on the screen. For more information on calibration, refer to the online help or the user documentation.

CHAPTER 3

Video Display Options

This chapter provides guidelines for adjusting the video display and using the monitor controls to adjust the image to your liking. Before you make any adjustments:

- Be sure to adjust the controls in your normal lighting conditions.
- Display a test image or pattern whenever you adjust the video.

Adjusting the M170 Video Display

Your M170 FPD monitor has four main controls to adjust the video display. Three of these buttons are actually hot keys meaning that if the MENU key is not pressed first, these buttons control VOLUME, AUTO ADJUST, and BRIGHTNESS instantly.

Figure 13. Video Display Controls

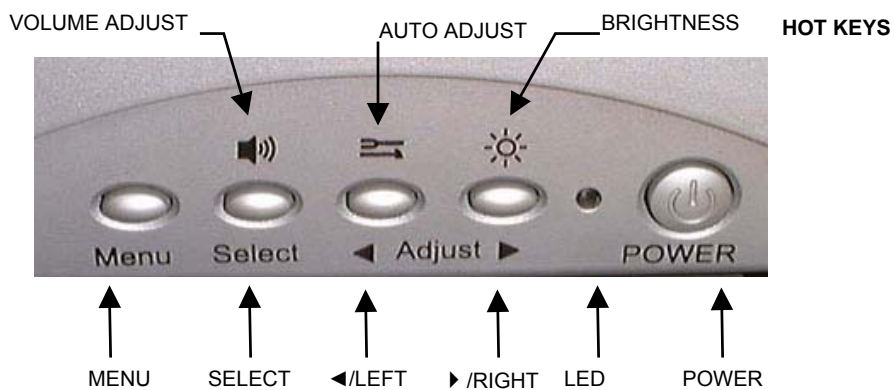

- MENU – Shows or hides the menu.
- SELECT -- Highlights the current menu option or saves the current setting. Press ► or ◀ to change the value.
- ◀/Left -- Enables you to scroll backwards through items on the menu -- decrease the value of selected option or move to the previous menu item.
- ►/Right -- Enables you to scroll forward through items on the menu -- increase the value of selected option or move to the next menu item.





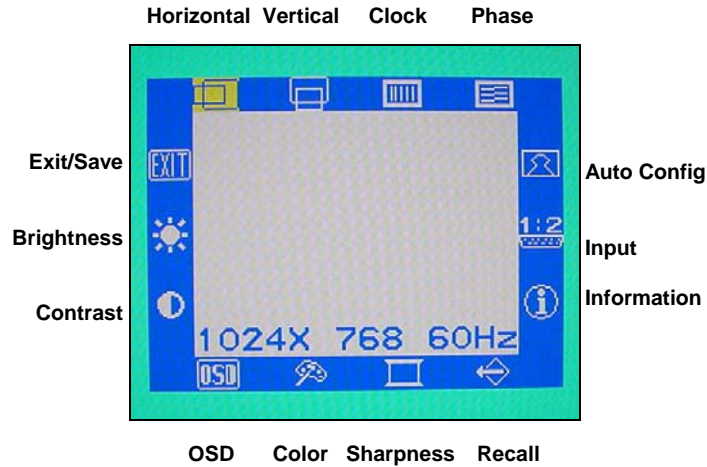

If you do not press the Menu, Select, or ◀/left or ▶/right adjust buttons for 45 seconds, the monitor adjustment program times out and hides the menu options. You can press the Menu button at any time to display the options again.

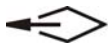

Pressing MENU will pull up the On Screen Display (OSD) menu, as shown below.

Figure 14. M170 Main Menu Options



Icon	Description
	H POSITION (Horizontal Position) Moves image horizontally on screen either left (◀) or right (▶).
	V POSITION (Vertical position) Moves images vertically on screen either up (▲) or down (▼).
	PHASE If the phase of your monitor is not fine-tuned, you may observe unstable horizontal noise lines and cross-talk stretching from the edge of small windows on your display. If you do an Auto Tracking, the monitor will try to find the best Clock/Phase setting. If you are not satisfied with the auto adjustment, fine-tune the phase manually as described above
	CLOCK If the clock setting of your image is not fine-tuned, you may observe periodic vertical bars of video noise on your image. These bars of noise are usually adjusted out when an Auto Configuration is performed. If the bars of noise are still present, this setting can be adjusted manually. Adjust this setting so that either the vertical bars of noise are replaced by an even amount of noise across the whole screen, or the noise disappears completely. If you do an Auto Tracking, the monitor will try to find the best Clock/Phase setting. If you are not satisfied with the auto adjustment, fine-tune the clock manually as described above.

Icon	Description
	<p>AUTO CONFIG If you change your display to Windows shut down mode, this adjustment will work better. Click on the "Start" button at the bottom right side, and then click Shut Down. This will bring you to the Windows shutdown mode. Then select Auto Adjust. The screen will adjust within 4 seconds.</p> <p>AUTO ADJUST Performs automatic configuration of the Phase, Clock, vertical, and horizontal position.</p> <p>AUTO TRACKING Tunes the clock and phase to the best condition automatically.</p> <p>AUTO POSITION Centers the image automatically. Both horizontal and vertical position is adjusted such that the image is centered on the panel.</p> <p>AUTO COLOR Adjusts the gain and offset of the Red, Green and Blue channels on the ADC automatically.</p>
	<p>1:2 INPUT LEVEL Selects the applicable input source analog input (D-sub), or digital input (DVI-D).</p>
	<p>INFORMATION Provides the user with detailed information regarding the current input format and version (including resolution, pixel clock, vertical /horizontal frequency, software version, and input source).</p>
	<p>RECALL Resets the control functions back to the original factory preset values. In order for the Recall function to work, the timing must fall under one of the factory preset timing modes.</p>
	<p>SHARPNESS Adjusts the video quality to be sharp or blurry (special for text mode).</p>
	<p>COLOR TEMPERATURE Adjusts color temperature to PRESET 1 (9300 color temperature) or PRESET 2 (6500 color temperature). Or, for a custom color mode, select USER and push the select button to activate the RGB submenu. This adjusts the intensity of the RGB video output. Using the select button activate the Red (Red Gain), Green (Green Gain) or Blue (Blue Gain) and change color strength for a customized color mode. By adjusting a single color, you can make the picture look warmer (biased towards red) or cooler (biased towards blue). Adjusting all three levels will make colors appear more or less striking.</p>
	<p>OSD Adjust the OSD image horizontally or vertically by pressing the Select button. H-position moves the OSD position left or right. V-position moves the OSD position up or down.</p>

Icon	Description
	<p>OSD BLENDING: To adjust the brightness of the OSD MENU.</p> <p>LANGUAGE Selects a language among English, German, French, Spanish, Italian, Simplified Chinese or Traditional Chinese.</p>
	<p>CONTRAST Selecting the Contrast option increases (▲) or decreases (▼) the strength (lightness or dimness) of the image. Adjust the contrast using the ◀/left and ▶/right arrow buttons, and press SELECT to confirm the new setting.</p>
	<p>BRIGHTNESS Selecting the Brightness option will allow you to adjust the brightness of the display. Adjust the brightness using the ◀/left and ▶/right arrow buttons, and press SELECT to confirm the new setting.</p>
<p>EXIT</p>	<p>EXIT Exits the OSD menu and choose to save any settings (or not).</p>

Lock Out Feature

Once you have fine-tuned your display, you may want to restrict users from inadvertently making changes. In order to do this, follow this simple procedure. Repeat the procedure to restore access.

1. Press MENU and SELECT. Hold both keys for 10 seconds. DO NOT RELEASE.
2. Then press the POWER key to turn the monitor off.
3. Release MENU and SELECT.
4. Press the POWER key to turn the monitor back on.

CHAPTER 4

Maintenance and Troubleshooting

If you have a problem setting up or using your monitor, you may be able to solve it yourself. Before calling 3M Touch Systems, try the suggested actions that are appropriate to the problems you are experiencing with the monitor. You may also want to consult your video card user's manual for additional troubleshooting advice.

Maintaining Your Touch Monitor

To maintain your display and keep your monitor operating at peak performance:

- Keep your monitor and screen clean.
- Adjust the monitor video controls. Refer to Chapter 3 for more information.
- Do not install the display in a place where ventilation may be hindered. Always maintain adequate ventilation to protect the display from overheating and to ensure reliable and continued operation.

Touch Screen Care and Cleaning

The touch screen requires very little maintenance. 3M Touch Systems recommends that you periodically clean the glass touch screen surface.

Typically, an isopropyl alcohol and water solution ratio of 50:50 is the best cleaning agent for your touch screen. You can also use straight isopropyl alcohol. In addition, 3M Screen and Keyboard Cleaner CL680 has been tested and approved for this use.

CAUTION

To avoid the potentially hazardous situations associated with the use of alcohol or other solvents which may result in minor or moderate injury or property damage:

- Follow all instructions and recommendations in the manufacturer's Material Safety Data Sheet and product label.
- Be sure to follow solvent manufacturer's precautions and directions for use when using any solvents
- It is important to avoid using any caustic chemicals on the touch screen. Do not use any vinegar-based solutions.

- Apply the cleaner with a soft, lint-free cloth. Avoid using gritty cloths.

- Always dampen the cloth and then clean the screen. Be sure to spray the cleaning liquid onto the cloth, not the screen, so that drips do not seep inside the display or stain the bezel.
- Always handle the touch screen with care. Do not pull on or stress cables.

Monitor Installation Problems

Problem	Possible Causes and Solutions
No image displayed (blank screen)	<p>Is the monitor receiving power?</p> <ul style="list-style-type: none"> • Check that the computer's power cable is connected properly and securely in a grounded electrical outlet. • Check that the AC/DC power supply is firmly plugged into the monitor. • Check that the green light appears on the bezel indicating the monitor is powered on and receiving a signal. • Check that the AC/DC power supply cable is connected properly and securely to an electrical outlet. Check that the LED is showing green on the AC/DC power supply. • Try using another power cable. • Try using another electrical outlet. <p>Is the monitor receiving a valid video signal from the PC?</p> <ul style="list-style-type: none"> • Check that the computer is powered on. • Check that the video cable is connected properly and securely to the monitor and the computer. • Check that no pins are bent in the video cable connector. • Check that the video card is firmly seated in the card slot in your computer. • Check that the video input from the video card falls within the refresh rate of the display. Refer to Table 1 for details. • Check that your computer is using a supported display mode. Refer to Table 1 for details. <p>Is the monitor in Power Management mode?</p> <ul style="list-style-type: none"> • Touch the screen, press any key on the keyboard, or move the mouse to restore operation. <p>Are the brightness and contrast settings too low?</p> <ul style="list-style-type: none"> • Use the monitor controls to adjust these values.
Abnormal image	<ul style="list-style-type: none"> • Check that the video input from the video card falls within the refresh rate of the display. Refer to Table 1 for details. • Check that the video cable is connected properly and securely to the monitor and the computer. • Perform an Auto Config.
Colors of image are abnormal	<ul style="list-style-type: none"> • Check that the video cable is connected properly and securely to the monitor and the computer. • Check that no pins are bent in the video cable connector.
Disturbances on the screen	<ul style="list-style-type: none"> • The video display adjustments are incorrect. Refer to Chapter 3 for adjusting procedures.

Troubleshooting the Touch Screen

If you are experiencing problems with the touch screen, check the following list of common installation errors.

Table 3. Common Touch Screen Installation Issues

Common Installation Issues	Possible Solutions
Touch screen does not respond to touch	<ul style="list-style-type: none"> • Review the installation procedures. Are all cables connected properly? • After you installed Touch Software, did you restart your PC to activate the touch screen driver? • Are the communication settings correct? Is the touch screen trying to use the COM port or IRQ of another device (for example, a mouse)? If so, a hardware device conflict will result and the touch screen will not work.
Touch screen is not accurate	<ul style="list-style-type: none"> • Calibrate the touch screen for the current video resolution and operating system.
Cursor does not follow finger movement or does not reach the edges of the screen	<ul style="list-style-type: none"> • Calibrate the touch screen for the current video resolution and operating system.
Cursor is not located directly underneath your finger	<ul style="list-style-type: none"> • Open the touch screen control panel and make sure all cursor offsets (vertical, edge/horizontal) are turned off. • Calibrate the touch screen for the current video resolution and operating system.
Cursor is extremely jittery or erratic	<ul style="list-style-type: none"> • Stabilize the cursor by adjusting the operating frequency of the touch screen controller using the touch screen control panel.

Power Management

The M170 monitor conforms to the Video Electronics Standards Association (VESA) Display Power Management Signaling (DPMS) standard. To benefit from power management, the monitor must be used in conjunction with a computer and video card that implements the VESA DPMS standard.

The PC automatically invokes the power management feature if you do not use the touch screen, mouse, or keyboard for a user-defined period of time. To restore the video image, simply touch the screen, press a key, or move the mouse.

M170 Regulatory Agency Approvals

Your product complies with the following regulatory standards:

- FCC-B
- CE
- UL/cUL
- VCCI
- CCC
- C-tick
- RoHS/WEEE directives

This equipment has been tested and found to comply within limits for a Class B digital device, pursuant to Part 15 of the FCC rules. These limits are designed to provide reasonable protection against harmful interference in residential installations. This equipment generates, uses and can radiate radio frequency energy, and if not installed and used in accordance with the instructions, may cause harmful interference to radio communications. However, there is no guarantee that interference will not occur in a particular installation. If this equipment does cause interference to radio or television equipment reception, which can be determined by turning the equipment off and on, the user is encouraged to try to correct the interference by one or more of the following measures:

- Reorient or relocate the receiving antenna.
- Move the equipment away from the receiver.
- Consult the dealer or an experienced radio/television technician for additional suggestions.

 CAUTION
--

You are cautioned that any change or modification to the equipment not expressly approved by the party responsible for compliance could void your authority to operate such equipment.
--

This Class B digital apparatus meets all requirements of the Canadian Interference-Causing Equipment Regulations.

Cet appareil numérique de la classe B respecte toutes les exigences du Règlement sur le matériel brouilleur du Canada.

This device complies with Part 15 of the FCC rules: Operation is subject to the following two conditions: (1) This device may not cause harmful interference, and (2) this device must accept any interference received, including interference that may cause undesired operation.

FCC Warning

To assure continued FCC compliance, the user must use grounded power supply cord and the provided shielded video interface cable with bonded ferrite cores. If a BNC cable is going to be used, use only a shielded BNC(5) cable. Also, any unauthorized changes or modifications not expressly approved by the party responsible for compliance could void the user's authority to operate this device.

3M Touch Systems is not responsible for any radio or television interference caused by using other than recommended cables and connectors or by unauthorized changes or modifications to this equipment.

CE Conformity for Europe

The device complies with the requirements of the ECC directive 89/336/EEC as amended by 92/31/EEC and 93/68/EEC Art.5 with regard to "Electromagnetic compatibility", and 73/23/EEC as amended by 93/68/EEC Art.13 with regard to "Safety".

M170 Base Plate Mounting Template

(Drawn actual size)

3M Touch Systems Proprietary Information

Rear Edge of
Base Not Shown

Drill 4 Mounting Holes
0.178" (4.5 mm) Dia.

5.71" (145 mm)

Place this template on mounting surface and drill four holes as shown for mounting screws.
The screw heads must be smaller than 0.39" (10 mm) and larger than 0.21" (5.5 mm).
Adjust height of screw heads to securely lock monitor in place. This height is about 0.178" (4.5 mm).

3.74" (95 mm)

0.21" (5.5 mm)

Locking
Mechanism
Receptacle

0.39" (10 mm)

0.70" (17.8 mm)

Front Edge
of Base