

AMRP145H

Projector Hanger

The AMRP145H is a heavy duty ceiling projector mount made to hold projectors up to a maximum weight of 55.1 lbs or 25 Kg. The unit has a sleek look with its high quality aluminum and synthetic materials. It supports an in-tube cable management system and a flexible ball joint allowing for different angle placement of a projector.

The AMRP145H features include:

- In Tube Cable Management System
- Patented Ball Joint Structure
- Universal Projector Mount 325mm Dia
- Height Adjustment
- Aluminum Structure
- SGS Tensile Approval



Specifications

General

Screw Type:	• M3 M4 M5 M6	Material:	• Steel/Aluminum Alloy/Plastic
Weight:	• 1.72Kg / 3.79lbs	Support Max Weight:	• 25Kg / 55.1lbs
Compatibility:	• Compatible with projectors with hole patterns up to 325mm	Projector Tilt:	• Up to +/-25°
Dimension (W x H x D):	• 352.5 x 352.5 x 577.7mm 13.88" x 13.88" x 24.74"	Swivel:	• 360°

Warranty and Support

Warranty: 3 Years
Support: Free technical support (phone/email)

AMRP145H

Projector Hanger

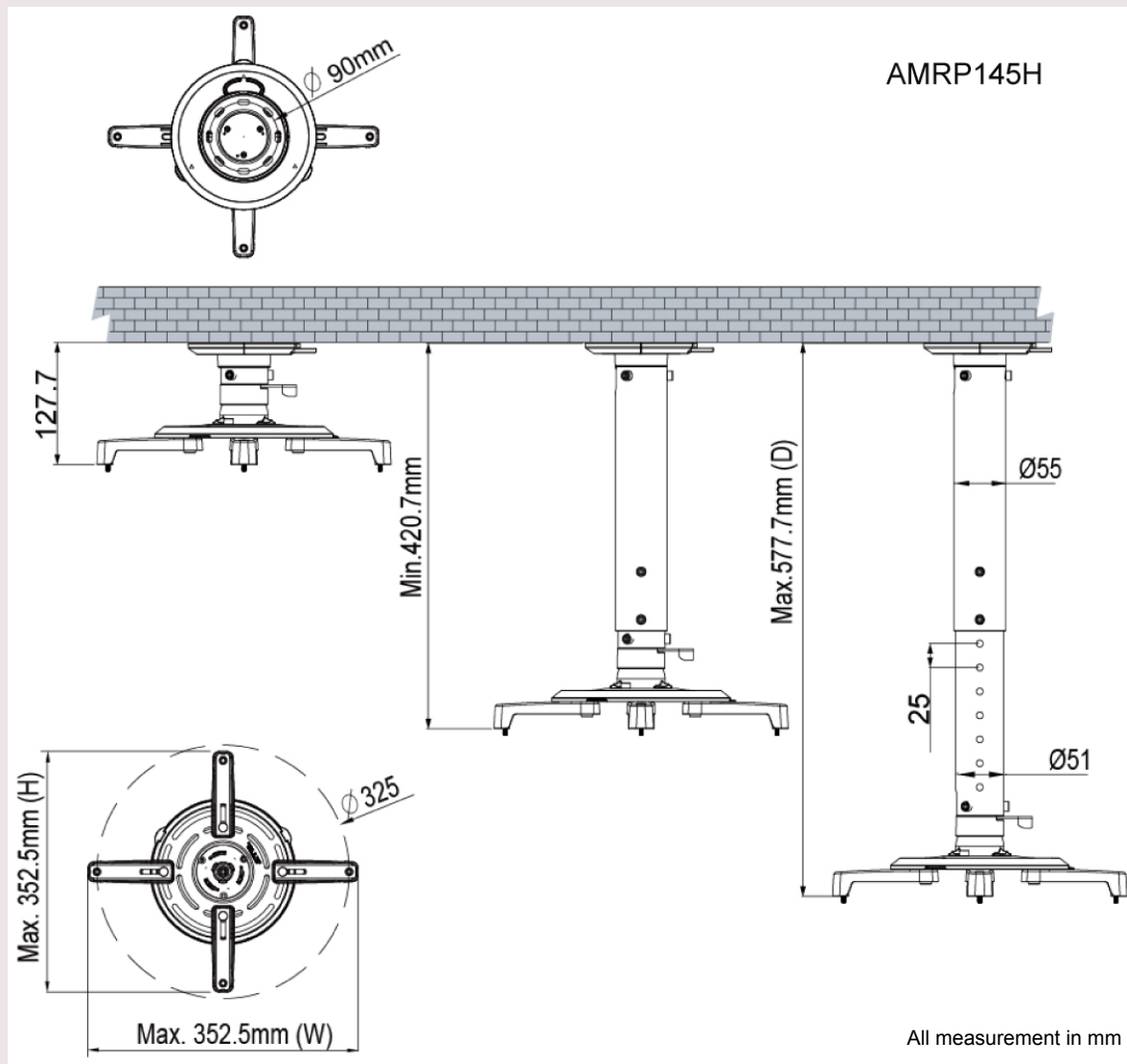

www.amer.com / www.amermounts.com

sales@amer.com
1-800-262-9703

Specifications subject to change without notice. Errors and omissions excepted. All trademarks are properties of their respective owners.

Revision 2.02