

VPL-SW125 Projector

WXGA resolution short throw projector with 2600 lumens brightness



The VPL-SW125 WXGA projector delivers a 0.62:1 throw ratio that produces a 2.03M (80") diagonal screen size image from only 1.1 metre (3.6 feet) away from the screen. This projector has been designed to be easy to operate and to deliver a low total cost of ownership. It is an ideal choice for close projection applications in the corporate and educational markets.

Furthermore, in common with all Sony projectors, the VPL-SW125 features the Sony BrightEra 3LCD inorganic panel technology that delivers higher picture quality, substantially brighter images, higher efficiency, better contrast, consistent colour stability and longer durability and usability.

The VPL-SW125 also features 3 different brightness modes to suit each individual user's needs. In the high brightness mode, the projector has a brightness of 2600 lumens. The low brightness mode generates lower operating costs by reducing power consumption and extending the lamp lifetime to approximately 6000 hours. This projector also has a contrast ratio of 3800:1, video inputs and RJ45 or RS232C connectors for control.

Key Features

6000 hours Lamp Life

New driving scheme reduces gap expansion which minimises brightness gradation. A new cooling system allows uniformity in the temperature of the glass bulb which prevents the glass from clouding.

3LCD BrightEra Technology

The Sony 0.59 inch BrightEra inorganic TFT 3-LCD panels deliver improved panel light resistance, higher resolution, high brightness and increased panel reliability.

Eco Mode Key

Users can easily select power-saving Eco Modes. The most energy-efficient mode is accessible through a single button-push, and further adjustments are available through an easily understood menu system.



Maximum 2600 lumens brightness with High, Standard and Low modes

The VPL-SW125 features three brightness modes for different uses – High for naturally white presentations in bright rooms, Standard for everyday use and Low for video in darkened rooms.



Picture Freeze Function

Picture Freeze is useful during presentations where users need to look at other material on their PC's screens without the viewing audience being aware. Freeze the current image and users can use their PC independently of the display from the projector.



Off and Go

At the end of a presentation, users can turn off the power supply to the projector immediately, instead of going through a 'power down' cycle.



Direct Power On/Off

With this function, there is no need to go through 'Standby' mode when powering up the projector. The projector can be set to activate as soon as power is supplied.



Picture Muting

If the picture needs to be turned off, all it takes is a single button-press on the remote control. This will mute audio at the same time. There is also a separate 'mute audio' button for audio-only muting.

Other Features

0.62 throw ratio

The VPL-SW125 offers a 0.62:1 throw ratio that produces a 2.03M (80") diagonal screen size image from only 1.1M (3.6 feet) away from the screen.

WXGA Resolution

The VPL-SW125 has a colour light output of 2600 ANSI lumens and with a native WXGA (1280 x 800) widescreen resolution panel, is perfect for video or presentations direct from a laptop or PC.

All Sony Professional's business projectors sold into the EU, Norway and Switzerland come supplied with a 3 year PrimeSupport pack. This offers unique services and benefits over and above standard warranty:-

3 Years Cover

Freephone telephone helpdesk support (00800 7898 7898) in 5 languages. Collection, repair and return anywhere in EU, Norway and Switzerland.

In addition, optional PrimeSupport Plus packs can be purchased which can further enhance the 3 year support to give extra peace of mind:-

- A 2 year extension of the standard 3 year PrimeSupport to give long-term assurance of expert support, technical assistance and repairs for 5 years from purchase date.
- Provision of a loan unit for 3 or 5 years cover to ensure minimal impact to the customer's business in case of product failure.
- Cover for a lamp failure throughout the 3 year PrimeSupport term for customers who don't want to have any unexpected running costs.

Prime Support

Prime Support Plus

Technical Specifications

Specifications	VPL-SW125	
Display system	3 LCD system	
Display device	Size of effective display area	0.59" (15.0 mm) x 3, BrightEra, Aspect ratio: 16:10
	Number of pixels	3,072,000 (1280 x 800 x 3) pixels
Projection lens	Zoom	-
	Focus	Manual
Throw Ratio	0.62:1	
Light source	High-pressure mercury lamp 210 W type	
Recommended lamp replacement time*1	3000 H / 4500 H / 6000 H (Lamp mode: High / Standard / Low)	
Filter cleaning cycle	Max. 6000 H*1 / Same time as the lamp replacement is recommended	
Screen size	50" to 110" (1.27 m to 2.794 m)*2	
Light output (Lamp mode: High / Standard / Low)	2600 lm / 1800 lm / 1400 lm	
Colour light output	2600 lm / 1800 lm / 1400 lm	
Contrast ratio (full white / full black)*3	3800:1	
Speaker	1 W x 1 (monaural)	
Displayable scanning frequency	Horizontal	19 kHz to 92 kHz
	Vertical	48 Hz to 92 Hz
Display resolution	Computer signal input	Maximum input signal resolution: 1400 x 1050 (resizing display) Panel display resolution: 1280 x 800 pixels
	Video signal input	NTSC, PAL, SECAM, 480/60i, 576/50i, 480/60p, 576/50p, 720/60p, 720/50p, 1080/60i, 1080/50i
Colour system	NTSC3.58, PAL, SECAM, NTSC4.43, PAL-M, PAL-N, PAL60	
Keystone correction	Vertical: Max. +/- 15 degrees*4	
OSD language	20-languages (English, Dutch, French, Italian, German, Spanish, Portuguese, Turkish, Polish, Russian, Swedish, Norwegian, Japanese, Simplified Chinese, Traditional Chinese, Korean, Thai, Vietnamese, Arabic, Persian)	
Computer and video signal input/output	INPUT A	RGB / Y PB PR input connector: Mini D-sub 15-pin (female), Audio input connector: Stereo mini jack
	INPUT B	HDMI™
	S VIDEO IN	S video input connector: Mini DIN-4 pin Audio input connector: Pin jack (x2) (shared with VIDEO IN)
	VIDEO IN	Video input connector: Pin jack, Audio input connector: Pin jack (x2) (shared with S-VIDEO IN)
Other signal input/output	OUTPUT	Monitor output connector*4: Mini D-sub 15-pin (female), Audio output connector*5: Stereo mini jack (variable out)
		RS-232C connector: D-sub 9-pin (female)
Operating temperature (Operating humidity)	LAN connector: RJ45, 10BASE-T/100BASE-TX 0°C to 40°C / 32°F to 104°F (20% to 80%; no condensation)	
Storage temperature (Storage humidity)	(-10°C to 60°C / 14°F to 140°F) (20% to 80%; no condensation)	

Specifications	VPL-SW125	
Power requirements	AC 100 V to 240 V, 3.0 A to 1.3 A, 50 Hz /60 Hz	
Power consumption	AC 100 V to 120 V	290W / 240W / 205W
	AC 220 V to 240 V	275W / 225W / 190W
Standby mode power consumption	AC 100 V to 120 V	3W / <1.0 W (Standby mode: Standard / Low)
	AC 220 V to 240 V	3 W / <1.0 W (Standby mode: Standard / Low)
Heat dissipation	AC 100 V to 120 V	990 BTU
	AC 220 V to 240 V	940 BTU
Standard outside dimensions	W 313.4 x H 160.3 x D 349.3 mm (W 12 11/32 x H 6 5/16 x D 13 3/4 in) W 313.4 x H 144.9 x D 349.3 mm (W 12 11/32 x H 5 23/32 x D 13 3/4 in) (without protrusion)	
Mass	3.7kg / 8lb 3oz	
Supplied accessories	RM-PJ7 Remote Commander (1), Lithium Battery: CR2025 (1) Mini D-sub 15-pin cable (1), Operating Instructions (1) Quick Reference Manual (1), AC power cord (1)	
Optional accessories	LMP-E211 Projector Lamp, PAM-200 Mounting Bracket	

- *1: The figures are expected maintenance time and not guaranteed. They will depend on the environment or how the projector is used.
- *2: Viewable area, measured diagonally.
- *3: The value is average.
- *4: Depends on resolution.
- *5: From INPUT A and INPUT B.
- *6: Works as audio switcher function. From current channel only. Not available in standby.

Dimensions

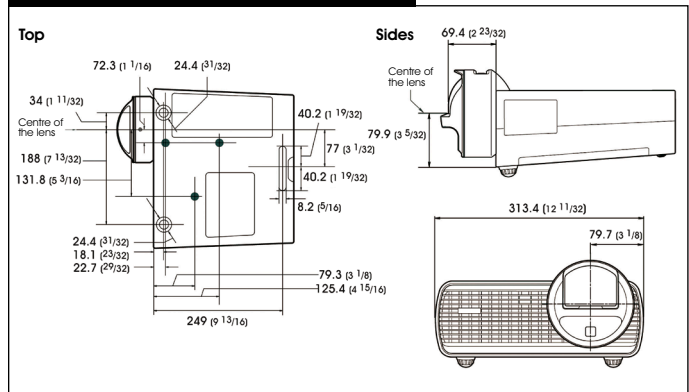

Connector Panels

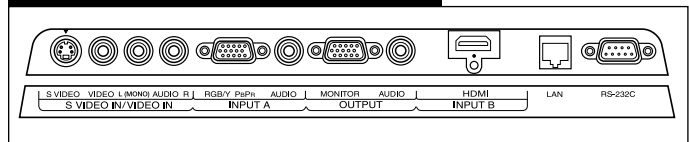

© 2011 Sony Corporation. All rights reserved. Reproduction in whole or in part without permission is prohibited. Features and specifications are subject to change without notice. All non-metric weights and measurements are approximate. Sony and make.believe are trademarks of Sony Corporation. All other trademarks are the property of their respective owners.

Distributed by

About Sony Professional

Sony Professional is the leading supplier of AV/IT solutions to businesses across a wide variety of sectors including, Media and Broadcast, Video Security and Retail, Transport & Large Venue markets. It delivers products, systems and applications to enable the creation, manipulation and distribution of digital audio-visual content that add value to businesses and their customers. With over 25 years' experience in delivering innovative market-leading products, Sony Professional is ideally placed to deliver exceptional quality and value to its customers. Sony's Professional Services division, its systems integration arm, offers its customers access to the expertise and local knowledge of skilled professionals across Europe. Collaborating with a network of established technology partners, Sony Professional delivers end to end solutions that address the customer's needs, integrating software and systems to achieve each organisations' individual business goals. For more information please visit www.pro.sony.eu

HCT_VPL-SW125_10537_UK_06/2011

SONY
make.believe